



YASKAWA

efesotomasyon.com

# YASKAWA AC Drive-V1000

## Compact Vector Control Drive

### Quick Start Guide

**Type:** CIMR-VU

**Models:** 200 V Class, Three-Phase Input: 0.1 to 18.5 kW  
200 V Class, Single-Phase Input: 0.1 to 3.7 kW  
400 V Class, Three-Phase Input: 0.2 to 18.5 kW

To properly use the product, read this manual thoroughly and retain for easy reference, inspection, and maintenance. Ensure the end user receives this manual.

Contém manual suplementar em Português.

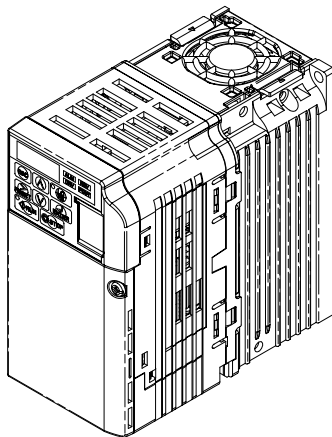

Receiving

1

Mechanical Installation

2

Electrical Installation

3

Start-Up Programming & Operation

4

Troubleshooting

5

Specifications

6

Parameter List

7

Standards Compliance

8

efesotomasyon.com

---

**This Page Intentionally Blank**

Copyright © 2008 YASKAWA ELECTRIC CORPORATION. All rights reserved.

All rights reserved. No part of this publication may be reproduced, stored in a retrieval system, or transmitted, in any form or by any means, mechanical, electronic, photocopying, recording, or otherwise, without the prior written permission of Yaskawa. No patent liability is assumed with respect to the use of the information contained herein. Moreover, because Yaskawa is constantly striving to improve its high-quality products, the information contained in this manual is subject to change without notice. Every precaution has been taken in the preparation of this manual. Yaskawa assumes no responsibility for errors or omissions. Neither is any liability assumed for damages resulting from the use of the information contained in this publication.



# Table of Contents

---

<b>i. PREFACE &amp; GENERAL SAFETY .....</b>	<b>9</b>
<b>i.1 Preface .....</b>	<b>10</b>
Applicable Documentation .....	10
Symbols.....	10
Terms and Abbreviations.....	11
<b>i.2 General Safety .....</b>	<b>12</b>
Supplemental Safety Information.....	12
Safety Messages .....	13
Drive Label Warnings .....	17
<b>i.3 Application Precautions .....</b>	<b>18</b>
General Application Precautions .....	18
Installation Environment .....	19
Settings .....	19
General Handling.....	20
Notes on Motor Operation.....	21
<b>1. RECEIVING .....</b>	<b>25</b>
<b>1.1 Model Number and Nameplate Check.....</b>	<b>26</b>
Nameplate.....	26
<b>1.2 Component Names .....</b>	<b>29</b>
IP20/Open-Chassis .....	29
IP00/Open-Chassis .....	31

## Table of Contents

---

IP20/NEMA Type 1 Enclosure .....	32
Front Views .....	35
<b>2. MECHANICAL INSTALLATION .....</b>	<b>37</b>
<b>2.1 Mechanical Installation .....</b>	<b>38</b>
Installation Environment .....	38
Installation Orientation and Spacing .....	39
Exterior and Mounting Dimensions .....	42
<b>3. ELECTRICAL INSTALLATION .....</b>	<b>49</b>
<b>3.1 Standard Connection Diagram .....</b>	<b>50</b>
<b>3.2 Terminal Block Configuration .....</b>	<b>53</b>
<b>3.3 Protective Covers .....</b>	<b>54</b>
IP20/Open-Chassis Front and Bottom Cover Removal and Installation .....	54
IP20/NEMA Type 1 Front and Bottom Cover Removal and Installation .....	55
IP20/NEMA Type 1 Top Cover Removal and Installation .....	57
<b>3.4 Main Circuit Wiring .....</b>	<b>59</b>
Main Circuit Terminal Functions .....	59
Wire Gauges and Tightening Torque .....	59
Main Circuit Terminal Power Supply and Motor Wiring .....	62
<b>3.5 Control Circuit Wiring .....</b>	<b>65</b>
Control Circuit Terminal Block Functions .....	65
Terminal Configuration .....	68
Wiring Procedure .....	70
<b>3.6 I/O Connections .....</b>	<b>72</b>
Sinking/Sourcing Mode Switch .....	72
<b>3.7 Main Frequency Reference .....</b>	<b>75</b>
DIP Switch S1 Analog Input Signal Selection .....	75
<b>3.8 Wiring Checklist .....</b>	<b>77</b>
<b>4. START-UP PROGRAMMING &amp; OPERATION .....</b>	<b>79</b>
<b>4.1 Using the Digital LED Operator .....</b>	<b>80</b>

Keys, Displays, and LEDs.....	80
LED Screen Displays.....	82
LO/RE LED and RUN LED Indications .....	82
Menu Structure for Digital LED Operator.....	83
<b>4.2 The Drive and Programming Modes .....</b>	<b>84</b>
Changing Parameter Settings or Values .....	84
Switching Between LOCAL and REMOTE.....	85
Parameters Available in the Setup Group.....	85
<b>4.3 Start-up Flowcharts .....</b>	<b>87</b>
Flowchart A: Basic Start-up and Motor Tuning .....	88
Subchart A1: Simple Motor Setup with Energy Savings or Speed Search Using V/f Mode.....	89
Subchart A2: High Performance Operation Using Open Loop Vector Motor Control .....	90
Subchart A3: Operation with Permanent Magnet Motors .....	91
<b>4.4 Powering Up the Drive .....</b>	<b>92</b>
Powering Up the Drive and Operation Status Display .....	92
<b>4.5 Application Selection.....</b>	<b>93</b>
Setting 1: Water Supply Pump Application .....	93
Setting 2: Conveyor Application .....	94
Setting 3: Exhaust Fan Application .....	95
Setting 4: HVAC Fan Application.....	96
Setting 5: Compressor Application.....	96
Setting 6: Preset 6 .....	97
Notes on Controlling the Brake when Using Application Preset 6.....	98
Setting 7: Preset 7 .....	100
<b>4.6 Basic Drive Setup Adjustments .....</b>	<b>102</b>
Control Mode Selection: A1-02 .....	102
Initialize Parameter Values: A1-03.....	102
Frequency Reference Source: b1-01.....	103
Run Command Input Selection: b1-02.....	105
Drive Duty Mode and Carrier Frequency Selection: C6-01 and C6-02.....	107
Drive Input Voltage Setting: E1-01.....	108
<b>4.7 Auto-Tuning.....</b>	<b>109</b>
Types of Auto-Tuning .....	109

## Table of Contents

---

Before Auto-Tuning the Drive .....	109
Auto-Tuning Interruption and Fault Codes .....	110
Performing Auto-Tuning .....	111
Auto-Tuning Example .....	113
Input Data for Auto-Tuning .....	115
<b>4.8 No-Load Operation Test Run .....</b>	<b>118</b>
No-Load Operation Test Run .....	118
<b>4.9 Test Run with Load Connected .....</b>	<b>120</b>
Test Run with the Load Connected .....	120
<b>4.10 Test Run Checklist .....</b>	<b>121</b>
<b>5. TROUBLESHOOTING .....</b>	<b>123</b>
<b>5.1 Drive Alarms, Faults, and Errors .....</b>	<b>124</b>
Types of Alarms, Faults, and Errors .....	124
<b>5.2 Fault Detection .....</b>	<b>125</b>
Fault Displays, Causes, and Possible Solutions .....	125
<b>5.3 Alarm Detection .....</b>	<b>140</b>
Alarm Codes, Causes, and Possible Solutions .....	140
<b>5.4 Operator Programming Errors .....</b>	<b>143</b>
oPE Codes, Causes, and Possible Solutions .....	143
<b>5.5 Auto-Tuning Fault Detection .....</b>	<b>144</b>
Auto-Tuning Codes, Causes, and Possible Solutions .....	144
<b>5.6 Diagnosing and Resetting Faults .....</b>	<b>147</b>
Fault Reset Methods .....	147
<b>6. SPECIFICATIONS .....</b>	<b>149</b>
<b>6.1 Heavy Duty and Normal Duty Ratings .....</b>	<b>150</b>
<b>6.2 Single/Three-Phase 200 V Class Drive .....</b>	<b>151</b>
<b>6.3 Three-Phase 400 V Class Drives .....</b>	<b>155</b>
<b>7. PARAMETER LIST .....</b>	<b>157</b>
<b>7.1 Parameter Table .....</b>	<b>158</b>

<b>8. STANDARDS COMPLIANCE .....</b>	<b>191</b>
<b>8.1 European Standards .....</b>	<b>192</b>
CE Low Voltage Directive Compliance .....	192
EMC Guidelines Compliance .....	194
<b>8.2 UL Standards .....</b>	<b>200</b>
UL Standards Compliance .....	200
Drive Motor Overload Protection .....	203
<b>8.3 Safe Disable Input Precautions .....</b>	<b>206</b>
Safe Disable Function Description .....	206
Installation .....	206
<b>8.4 V1000 - ORIENTAÇÃO BÁSICA .....</b>	<b>208</b>
INVERSORES - V1000 TERMO DE GARANTIA .....	208
INVERSORES DE FREQUÊNCIA - V1000 .....	208
Revision History .....	213

**This Page Intentionally Blank**



# Preface & General Safety

---

This section provides safety messages pertinent to this product that, if not heeded, may result in fatality, personal injury, or equipment damage. Yaskawa is not responsible for the consequences of ignoring these instructions.

<b>i.1</b>	<b>PREFACE.....</b>	<b>10</b>
<b>i.2</b>	<b>GENERAL SAFETY.....</b>	<b>12</b>
<b>i.3</b>	<b>APPLICATION PRECAUTIONS.....</b>	<b>18</b>

# i.1 Preface

Yaskawa manufactures products used as components in a wide variety of industrial systems and equipment. The selection and application of Yaskawa products remain the responsibility of the equipment manufacturer or end user. Yaskawa accepts no responsibility for the way its products are incorporated into the final system design. Under no circumstances should any Yaskawa product be incorporated into any product or design as the exclusive or sole safety control. Without exception, all controls should be designed to detect faults dynamically and fail safely under all circumstances. All systems or equipment designed to incorporate a product manufactured by Yaskawa must be supplied to the end user with appropriate warnings and instructions as to the safe use and operation of that part. Any warnings provided by Yaskawa must be promptly provided to the end user. Yaskawa offers an express warranty only as to the quality of its products in conforming to standards and specifications published in the Yaskawa manual. **NO OTHER WARRANTY, EXPRESSED OR IMPLIED, IS OFFERED.** Yaskawa assumes no liability for any personal injury, property damage, losses, or claims arising from misapplication of its products.

---

## ◆ Applicable Documentation

The following manuals are available for V1000 series drives:

	V1000 Series AC Drive Quick Start Guide
	Read this manual first. This guide is packaged together with the product. It contains basic information required to install and wire the drive. This guide provides basic programming and simple setup and adjustment. Refer to the V1000 Technical Manual for complete descriptions of drive features and functions.
	V1000 Series AC Drive Technical Manual
	This manual describes installation, wiring, operation procedures, functions, troubleshooting, maintenance, and inspections to perform before operation.

---

## ◆ Symbols

**Note:** Indicates a supplement or precaution that does not cause drive damage.



**Indicates a term or definition used in this manual.**

## ◆ Terms and Abbreviations



- **Drive:** Yaskawa V1000 Series Drive
- **PM motor:** Synchronous motor (an abbreviation for IPM motor or SPM motor)
- **IPM motor:** SSR1 Series
- **SPM motor:** SMRA Series SPM Motor
- **PG:** Pulse Generator

# i.2 General Safety

## ◆ Supplemental Safety Information

### General Precautions

- The diagrams in this manual may be indicated without covers or safety shields to show details. Restore covers or shields before operating the drive and run the drive according to the instructions described in this manual.
- Any illustrations, photographs, or examples used in this manual are provided as examples only and may not apply to all products to which this manual is applicable.
- The products and specifications described in this manual or the content and presentation of the manual may be changed without notice to improve the product and/or the manual.
- When ordering a new copy of the manual due to damage or loss, contact your Yaskawa representative or the nearest Yaskawa sales office and provide the manual number shown on the front cover.
- If nameplate becomes worn or damaged, order a replacement from your Yaskawa representative or the nearest Yaskawa sales office.

### WARNING

Read and understand this manual before installing, operating or servicing this drive. The drive must be installed according to this manual and local codes.

The following conventions are used to indicate safety messages in this manual. Failure to heed these messages could result in serious or possibly even fatal injury or damage to the products or to related equipment and systems.

### DANGER

**Indicates a hazardous situation, which, if not avoided, will result in death or serious injury.**

### WARNING

**Indicates a hazardous situation, which, if not avoided, could result in death or serious injury.**

**WARNING!** *will also be indicated by a bold key word embedded in the text followed by an italicized safety message.*

 **CAUTION**

Indicates a hazardous situation, which, if not avoided, could result in minor or moderate injury.

**CAUTION!** will also be indicated by a bold key word embedded in the text followed by an italicized safety message.

**NOTICE**

Indicates a property damage message.

**NOTICE:** will also be indicated by a bold key word embedded in the text followed by an italicized safety message.

◆ **Safety Messages**

 **DANGER**

**Heed the safety messages in this manual.**

Failure to comply will result in death or serious injury.

The operating company is responsible for any injuries or equipment damage resulting from failure to heed the warnings in this manual.

**Electrical Shock Hazard**

**Do not connect or disconnect wiring while the power is on.**

Failure to comply will result in death or serious injury.

Before servicing, disconnect all power to the equipment. The internal capacitor remains charged even after the power supply is turned off. The charge indicator LED will extinguish when the DC bus voltage is below 50 Vdc. To prevent electric shock, wait at least five minutes after all indicators are OFF and measure the DC bus voltage level to confirm safe level.

### **WARNING**

#### **Sudden Movement Hazard**

**System may start unexpectedly upon application of power, resulting in death or serious injury.**

Clear all personnel from the drive, motor and machine area before applying power. Secure covers, couplings, shaft keys and machine loads before applying power to the drive.

**When using DriveWorksEZ to create custom programming, the drive I/O terminal functions change from factory settings and the drive will not perform as outlined in this manual.**

Unpredictable equipment operation may result in death or serious injury.

Take special note of custom I/O programming in the drive before attempting to operate equipment.

#### **Electrical Shock Hazard**

**Do not attempt to modify or alter the drive in any way not explained in this manual.**

Failure to comply could result in death or serious injury.

Yaskawa is not responsible for any modification of the product made by the user. This product must not be modified.

**Do not allow unqualified personnel to use equipment.**

Failure to comply could result in death or serious injury.

Maintenance, inspection, and replacement of parts must be performed only by authorized personnel familiar with installation, adjustment and maintenance of AC drives.

**Do not remove covers or touch circuit boards while the power is on.**

Failure to comply could result in death or serious injury.

#### **Fire Hazard**

**Do not use an improper voltage source.**

Failure to comply could result in death or serious injury by fire.

Verify that the rated voltage of the drive matches the voltage of the incoming power supply before applying power.

 **WARNING**

**Crush Hazard**

**Do not use this drive in lifting applications without installing external safety circuitry to prevent accidental dropping of the load.**

**The drive does not possess built-in load drop protection for lifting applications.**

Failure to comply could result in death or serious injury from falling loads.

Install electrical and/or mechanical safety circuit mechanisms independent of drive circuitry.

 **CAUTION**

**Crush Hazard**

**Do not carry the drive by the front cover.**

Failure to comply may result in minor or moderate injury from the main body of the drive falling.

**NOTICE**

**Observe proper electrostatic discharge procedures (ESD) when handling the drive and circuit boards.**

Failure to comply may result in ESD damage to the drive circuitry.

**Never connect or disconnect the motor from the drive while the drive is outputting voltage.**

Improper equipment sequencing could result in damage to the drive.

**Do not perform a withstand voltage test on any part of the drive.**

Failure to comply could result in damage to the sensitive devices within the drive.

**Do not operate damaged equipment.**

Failure to comply could result in further damage to the equipment.

Do not connect or operate any equipment with visible damage or missing parts.

### NOTICE

**Install adequate branch circuit short circuit protection per applicable codes.**

Failure to comply could result in damage to the drive.

The drive is suitable for circuits capable of delivering not more than 30,000 RMS symmetrical Amperes, 240 Vac maximum (200 V Class) and 480 Vac maximum (400 V Class).

**Do not expose the drive to halogen group disinfectants.**

Failure to comply may cause damage to the electrical components in the drive.

Do not pack the drive in wooden materials that have been fumigated or sterilized.

Do not sterilize the entire package after the product is packed.



# i.3 Application Precautions

## ◆ General Application Precautions

### ■ Selecting a Reactor

An AC or DC reactor can be used for the following:

- to suppress harmonic current.
- to smooth peak current that results from capacitor switching.
- when the power supply is above 600 kVA.
- when the drive is running from a power supply system with thyristor converters.

**Note:** A DC reactor is built in to 200 V and 400 V class models with a capacity of 22 kW and higher (HD rating).

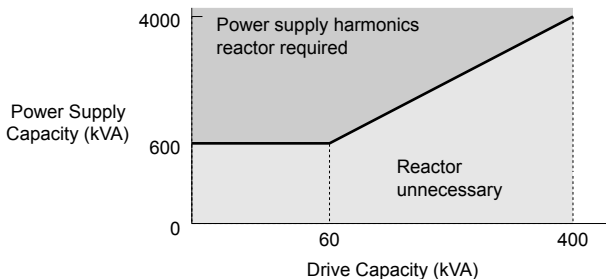

Figure i.3 Installing a Reactor

### ■ Drive Capacity

Make sure that the motor rated current is less than the rated nameplate output current of the drive. When running more than one motor in parallel from a single drive, the drive rated current should 1.1 times larger than the total motor rated current for all connected motors or nuisance drive faults may occur.

### ■ Starting Torque

The overload rating of the drive determines the starting and accelerating characteristics of the motor. Expect lower running torque than when running the motor from line power. To get more starting torque, use a larger drive or increase both the motor and drive capacity.

### ■ Emergency/Fast Stop

During a drive fault condition, a protective circuit is activated and drive output is shut off. The motor may coast to a stop or attempt to decelerate depending on parameter settings. If the emergency/fast stop cannot stop the load as fast as desired, a customer-supplied mechanical brake may be required. Test emergency stop circuitry before putting drive into operation.

### ■ Options

The B1, B2, +1, +2, and +3 terminals are used to connect optional power devices. Connect only devices compatible with the drive.

### ■ Repetitive Starting/Stopping

Applications with frequent starts and stops often exceed 150% of their rated current values. Heat stress generated from repetitive high current can shorten the life span of the IGBTs. The expected lifesaving for the IGBTs is about 8 million start and stop cycles with a 4 kHz carrier frequency and a 150% peak current.

Yaskawa recommends lowering the carrier frequency, particularly when audible noise is not a concern. The user can also choose to reduce the load, increase the acceleration and deceleration times, or switch to a larger drive. This will help keep peak current levels under 150%. Be sure to check the peak current levels when starting and stopping repeatedly during the initial test run, and make adjustments accordingly.

---

## ◆ Installation Environment

### ■ Enclosure Panels

Keep the drive in a clean environment by either selecting an area free of airborne dust, lint, and oil mist, or install the drive in an enclosure panel. Be sure to leave the required space between drives to provide for cooling, and that proper measures are taken so that the ambient temperature remains within allowable limits. Keep flammable materials away from the drive. If the drive must be used in an area where it is subjected to oil mist and excessive vibration, protective designs are available. Contact Yaskawa or your Yaskawa agent for details.

### ■ Installation Direction

The drive should be installed upright as specified in the manual.

---

## ◆ Settings

### ■ Motor Code

If using OLV/PM designed for permanent magnet motors (A1-02 = 5), make sure that the proper motor code is set in parameter E5-01 before performing a trial run.

## i.3 Application Precautions

---

### ■ Upper Limits

The drive is capable of running the motor up to 400 Hz. Due to the danger of accidentally operating the motor at high speed, be sure to set the upper frequency limit. The default setting for the maximum output frequency is 60 Hz.

### ■ DC Injection Braking

Motor overheat can result if there is too much current used during DC Injection Braking, or if the DC Injection Braking time is too long.

### ■ Acceleration/Deceleration Times

Acceleration and deceleration times are affected by how much torque the motor generates, the load torque, and the inertia moment ( $(GD^2)/4$ ). Set a longer accel/decel time when Stall Prevention is enabled. The accel/decel times are lengthened for as long as the Stall Prevention function is operating. For faster acceleration and deceleration, install a braking option or increase the capacity of the drive.

---

## ◆ General Handling

**NOTICE:** *Wiring Check. Never connect the power supply lines to output terminals U/T1, V/T2, or W/T3. Doing so will destroy the drive. Be sure to perform a final check of all control wiring and other connections before applying line power. Make sure there are no short circuits on the control terminals (+V, AC, etc.), as this could damage the drive.*

### ■ Selecting a Molded Case Circuit Breaker (MCCB) or Ground Fault Circuit Interrupter (GFCI)

Yaskawa recommends installing a GFCI on the line power supply to protect drive wiring and prevent damage in the event of component failure. An MCCB may also be used if permitted by the power system.

The GFCI should be designed for use with an AC drive (i.e., protected against harmonics)

MCCB selection depends on the power factor for the drive, determined by the power supply voltage, output frequency, and load.

Refer to the Peripheral Devices & Options chapter of the Technical Manual for more information on breaker installation. Note that a larger capacity breaker is needed when using a fully electromagnetic MCCB, as operation characteristics vary with harmonic current.

### ■ Magnetic Contactor (MC) Installation

Use an MC to ensure that line power to the drive can be completely shut off when necessary. The MC should be wired so that it opens when the drive fault output is triggered.

Avoid switching the MC on the power supply side more frequently than once every 30 minutes. Frequent switching can cause damage to the drive.

### ■ Inspection and Maintenance

**DANGER!** *Electrical Shock Hazard. Do not connect or disconnect wiring while the power is on. Failure to comply will result in death or serious injury. Disconnect all power to the drive, wait at least five minutes after all indicators are OFF, measure the DC bus voltage to confirm safe level, and check for unsafe voltages before servicing to prevent electrical shock. The internal capacitor remains charged even after the power supply is turned off. The charge indicator LED will extinguish when the DC bus voltage is below 50 Vdc.*

**CAUTION!** *Burn Hazard. Do not touch a hot drive heatsink. Failure to comply could result in minor or moderate injury. Shut off the power to the drive when replacing the cooling fan. To prevent burns, wait at least 15 minutes and make sure the heatsink has cooled to a safe level.*

**WARNING!** *Electrical Shock Hazard. Wait for at least the time specified on the drive warning label after opening the load switch on the output side before any inspection or maintenance of permanent magnet (PM) motors. Failure to comply could result in death or serious injury.*

**WARNING!** *Sudden Movement Hazard. Install a switch disconnect between the motor and the drive in applications where the machine can still rotate even though the drive has fully stopped. Unpredictable equipment operation may result in death or serious injury.*

**WARNING!** *Sudden Movement Hazard. Do not attempt to move a load that could potentially rotate the motor faster than the maximum allowable r/min when the drive has been shut off. Unpredictable equipment operation may result in death or serious injury.*

**NOTICE:** *Do not open and close the motor disconnect switch while the motor is running, as this may damage the drive.*

**NOTICE:** *If the motor is coasting, make sure the power to the drive is turned on and the drive output has completely stopped before closing the load switch.*

### ■ Wiring

All wire ends should use ring terminals for UL/cUL compliance. Use only the tools recommended by the terminal manufacturer for crimping.

### ■ Transporting the Drive

**NOTICE:** *Prevent the drive from contact with salts, fluorine, bromine, phthalate ester, and other such harmful chemicals. Never steam clean the drive. Failure to comply may cause damage to the drive components.*

---

## ◆ Notes on Motor Operation

### ■ Using a Standard Motor

#### Low Speed Range

The cooling fan of a standard motor is usually designed to sufficiently cool the motor at the rated speed. As the self-cooling capability of such a motor reduces with the speed, applying full torque at low speed will possibly damage the motor. To prevent motor damage from overheat, reduce the load torque as the motor slows. [Figure i.4](#) shows the allowable load characteristics for a Yaskawa standard motor. A motor designed specifically for operation with a drive should be used when 100% continuous torque is needed at low speeds.

## i.3 Application Precautions

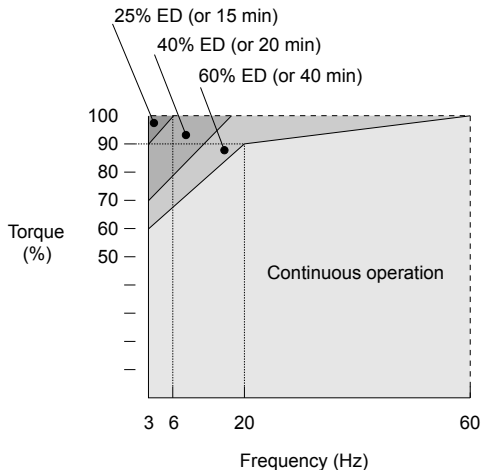

Figure i.4 Allowable Load Characteristics for a Yaskawa Motor

### Insulation Tolerance

Consider motor voltage tolerance levels and motor insulation in applications with an input voltage of over 440 V or particularly long wiring distances. Contact Yaskawa or your Yaskawa agent for consultation.

### High Speed Operation

Problems may occur with the motor bearings and dynamic balance of the machine when operating a motor beyond its rated speed. Contact the motor or machine manufacturer.

### Torque Characteristics

Torque characteristics differ compared to operating the motor directly from line power. The user should have a full understanding of the load torque characteristics for the application.

### Vibration and Shock

The drive settings allow the user to choose between high carrier PWM control and low carrier PWM. Selecting high carrier PWM can help reduce motor oscillation.

Take particular caution when using a variable speed drive for an application that is conventionally run from line power at a constant speed. If mechanical resonance occurs, install shock-absorbing rubber around the base of the motor and enable the Jump frequency selection parameter to prevent continuous operation in the resonant frequency range.

### Audible Noise

Noise created during run varies by the carrier frequency setting. When using a high carrier frequency, audible noise from the motor is comparable to the motor noise generated when running from line power. Operating above the rated r/min, however, can create unpleasant motor noise.

### ■ Using a Synchronous Motor

- Synchronous motors cannot be started directly from line power. Applications requiring line power to start should use an induction motor with the drive.
- A single drive is not capable of running multiple synchronous motors at the same time. Use a standard induction motor for such setups.
- At start, a synchronous motor may rotate slightly in the opposite direction of the Run command depending on parameter settings and motor type.
- The amount of starting torque that can be generated differs by each control mode and by the type of motor being used. Set up the motor with the drive after verifying the starting torque, allowable load characteristics, impact load tolerance, and speed control range.

Contact Yaskawa or your Yaskawa agent if you plan to use a motor that does not fall within these specifications.

- Braking Torque: In Open Loop Vector Control for PM motors, braking torque is less than 125% when running between 20% to 100% speed, even with a braking resistor. Braking torque drops to less than half when running at less than 20% speed.
- Load Inertia: In Open Loop Vector Control for PM motors, the allowable load inertia moment is approximately 50 times higher than the motor inertia moment or less. Contact Yaskawa or your Yaskawa agent concerning applications with a larger inertia moment.
- Holding Brake: When using a holding brake in Open Loop Vector Control for PM motors, release the brake prior to starting the motor. Failure to set the proper timing can result in speed loss. Not for use with conveyor, transport, or hoist type applications.
- Restarting a Coasting Motor: To restart a coasting motor rotating at over 200 Hz while in the V/f control mode, use the Short Circuit Braking function to first bring the motor to a stop. Short Circuit Braking requires a special braking resistor. Contact Yaskawa or your Yaskawa agent for details.

Speed Search can be used to restart a coasting motor rotating slower than 200 Hz. If the motor cable is relatively long, however, the motor should instead be stopped using Short Circuit Braking, which forces the motor to stop by creating a short-circuit in the motor windings.

### ■ Applications with Specialized Motors

#### **Multi-Pole Motor**

Because the rated current will differ from a standard motor, be sure to check the maximum current when selecting a drive. Always stop the motor before switching between the number of motor poles. If a regen overvoltage (oV) fault occurs or if overcurrent protection (oC) is triggered, the motor will coast to stop.

#### **Submersible Motor**

Because motor rated current is greater than a standard motor, select the drive capacity accordingly. Be sure to use a large enough gauge motor cable to avoid decreasing the maximum torque level on account of voltage drop caused by a long motor cable.

#### **Explosion-Proof Motor**

Both the motor and drive need to be tested together to be certified as explosion-proof. The drive is not designed for explosion proof areas.

Furthermore, if an encoder is attached to an explosion-proof motor make sure the encoder is also explosion-proof. Use an insulating signal converter for connecting the encoder signal lines to the drives speed feedback option card.

#### **Geared Motor**

To avoid gear damage when operating at low speeds or very high speeds, make sure that both the gear and lubricant are rated for the desired speed range. Consult with the manufacturer for applications that require operation outside the rated speed range of the motor or gear box.

#### **Single-Phase Motor**

Variable speed AC drives are not designed for operation with single phase motors. Using capacitors to start the motor causes excessive current to flow and can damage drive components. A split-phase start or a repulsion start can end up burning out the starter coils because the internal centrifugal switch is not activated. The drive is for use with 3-phase motors only.

#### **Motor with Brake**

Caution should be taken when using a drive to operate a motor with a built-in holding brake. If the brake is connected to the output side of the drive, it may not release at start due to low voltage levels. A separate power supply should be installed for the motor brake. Motors with a built-in brake tend to generate a fair amount of noise when running at low speeds.

### ■ Power Driven Machinery (decelerators, belts, chains, etc.)

Continuous operation at low speeds wears on the lubricating material used in gear box type systems to accelerate and decelerate power driven machinery. Caution should also be taken when operating at speeds above the rated machine speed due to noise and shortened performance life.



## Receiving

---

This chapter describes the proper inspections to perform after receiving the drive and illustrates the different enclosure types and components.

<b>1.1</b>	<b>MODEL NUMBER AND NAMEPLATE CHECK</b>	
	.....	<b>26</b>
<b>1.2</b>	<b>COMPONENT NAMES</b> .....	<b>29</b>

# 1.1 Model Number and Nameplate Check

Please perform the following tasks after receiving the drive:

- Inspect the drive for damage.  
If the drive appears damaged upon receipt, contact the shipper immediately.
- Verify receipt of the correct model by checking the information on the nameplate.
- If you have received the wrong model or the drive does not function properly, contact your supplier.

## ◆ Nameplate

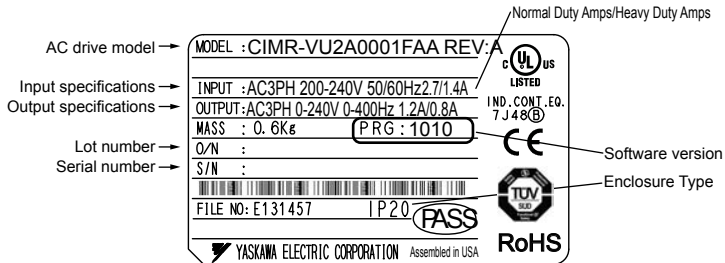
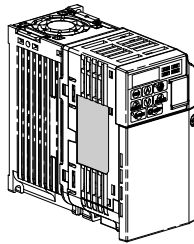
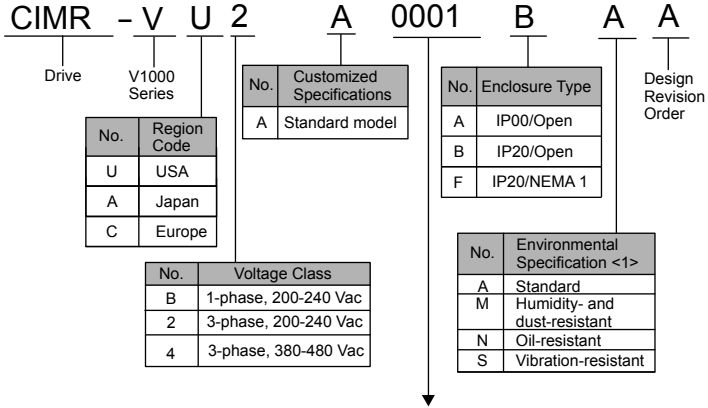

Figure 1.1 Nameplate Information

# 1.1 Model Number and Nameplate Check



## ■ Single-Phase 200 V

Normal Duty		
No.	Max. Motor Capacity kW	Rated Output Current A
0001	0.2	1.2
0002	0.4	1.9
0003	0.75	3.3
0006	1.1	6.0
0010	2.2	9.6
0012	3.0	12.0
—	—	—

Heavy Duty		
No.	Max. Motor Capacity kW	Rated Output Current A
0001	0.1	0.8
0002	0.2	1.6
0003	0.4	3.0
0006	0.75	5.0
0010	1.5	8.0
0012	2.2	11.0
0018	3.7	17.5

**Note:** CIMR-V□BA0018 is available with a Heavy Duty rating only.

## 1.1 Model Number and Nameplate Check

### ■ Three-Phase 200 V

Normal Duty		
No.	Max Motor Capacity kW	Rated Output Current A
0001	0.2	1.2
0002	0.4	1.9
0004	0.75	3.5
0006	1.1	6.0
0010	2.2	9.6
0012	3.0	12.0
0020	5.5	19.6
0030	7.5	30.0
0040	11	40.0
0056	15	56.0
0069	18.5	69.0

Heavy Duty		
No.	Max Motor Capacity kW	Rated Output Current A
0001	0.1	0.8
0002	0.2	1.6
0004	0.4	3.0
0006	0.75	5.0
0010	1.5	8.0
0012	2.2	11.0
0020	5.5	19.6
0030	5.5	25.0
0040	7.5	33.0
0056	11	47.0
0069	15	69.0

### ■ Three-Phase 400 V

Normal Duty		
No.	Max. Motor Capacity kW	Rated Output Current A
0001	0.4	1.2
0002	0.75	2.1
0004	1.5	4.1
0005	2.2	5.4
0007	3.0	6.9
0009	3.7	8.8
0011	5.5	11.1
0018	7.5	17.5
0023	11	23.0
0031	15	31.0
0038	18.5	38.0

Heavy Duty		
No.	Max. Motor Capacity kW	Rated Output Current A
0001	0.2	1.2
0002	0.4	1.8
0004	0.75	3.4
0005	1.5	4.8
0007	2.2	5.5
0009	3.0	7.2
0011	3.7	9.2
0018	5.5	14.8
0023	7.5	18.0
0031	11	24.0
0038	15	31.0

<1> Drives with these specifications do not guarantee complete protection for the specified environmental condition.

## 1.2 Component Names

This section illustrates the drive components as they are mentioned in this manual.

### ◆ IP20/Open-Chassis

- Single-Phase AC200 V CIMR-V□BA0001B ~ 0003B
- Three-Phase AC200 V CIMR-V□2A0001B ~ 0006B

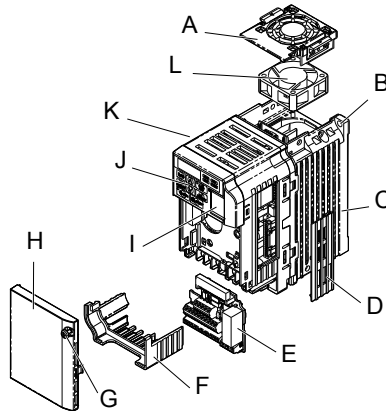

- |  |  |
|--|--|
| A – Fan cover <f>  | G – Front cover screw  |
| B – Mounting hole  | H – Front cover  |
| C – Heatsink   | I – Comm port  |
| D – Optional 24 V DC power supply connector cover                                      | J – LED operator <i>Refer to Using the Digital LED Operator on page 80</i> |
| E – Terminal board <i>Refer to Control Circuit Terminal Block Functions on page 65</i> | K – Case   |
| F – Terminal cover   | L – Cooling fan <f>  |

Figure 1.2 Exploded View of IP20/Open-Chassis Type Components  
Three-Phase AC200 V CIMR-V□2A0006B

- <f> The drives CIMR-V□BA0001B ~ 0003B and CIMR-V□2A0001B ~ 0004B do not have a cooling fan or a cooling fan cover.

## 1.2 Component Names

- Single-Phase AC200 V CIMR-V□BA0006B ~ 0018B
- Three-Phase AC200 V CIMR-V□2A0010B ~ 0020B
- Three-Phase AC400 V CIMR-V□4A0001B ~ 0011B

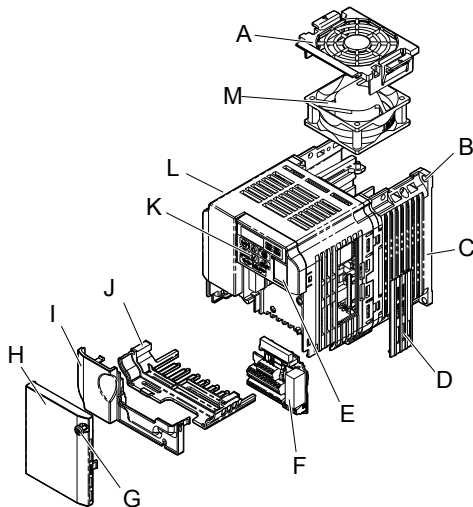

- A – Fan cover <1>
- B – Mounting hole
- C – Heatsink
- D – Optional 24 V DC power supply connector cover
- E – Comm port
- F – Terminal board [Refer to Control Circuit Terminal Block Functions on page 65](#)
- G – Front cover screw
- H – Front cover
- I – Terminal cover
- J – Bottom cover
- K – LED operator [Refer to Using the Digital LED Operator on page 80](#)
- L – Case
- M – Cooling fan <1>

Figure 1.3 Exploded view of IP20/Open-Chassis Type Components  
Three-Phase AC200 V CIMR-V□2A0012B

- <1> The drives CIMR-V□BA0006B and CIMR-V□4A0001B ~ 0004B do not have a cooling fan or a cooling fan cover. The drive CIMR-V□BA0018B has two cooling fans.

## ◆ IP00/Open-Chassis

- Three-Phase AC200 V CIMR-V□BA0030A ~ 0069A
- Three-Phase AC400 V CIMR-V□2A0018A ~ 0038A

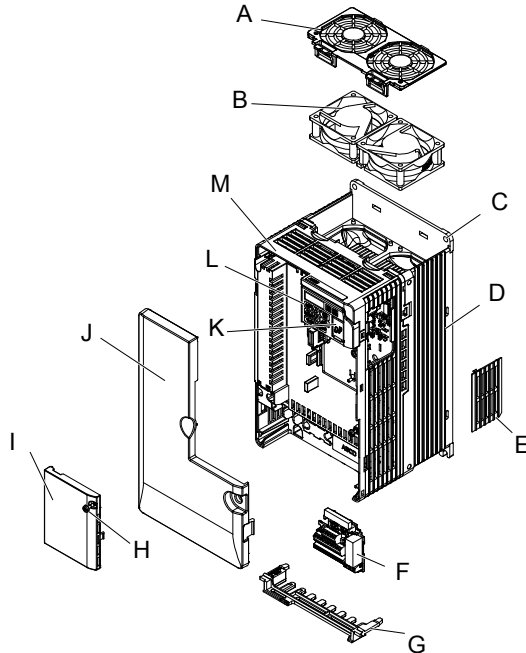

- |  |  |
|--|--|
| A – Fan cover  | H – Front cover screw  |
| B – Cooling Fan  | I – Front cover  |
| C – Mounting hole  | J – Terminal cover   |
| D – Heatsink   | K – Comm port  |
| E – Optional 24 VDC power supply connector cover                                       | L – LED operator <i>Refer to Using the Digital LED Operator on page 80</i> |
| F – Terminal board <i>Refer to Control Circuit Terminal Block Functions on page 65</i> | M – Case   |
| G – Bottom cover   |  |

Figure 1.4 Exploded View of IP00/Open-Chassis Type Components  
Three-Phase AC400 V CIMR-V□4A0018A

### ◆ IP20/NEMA Type 1 Enclosure

- Single-Phase AC200 V CIMR-V□BA0001F ~ 0003F
- Three-Phase AC200 V CIMR-V□2A0001F ~ 0006F

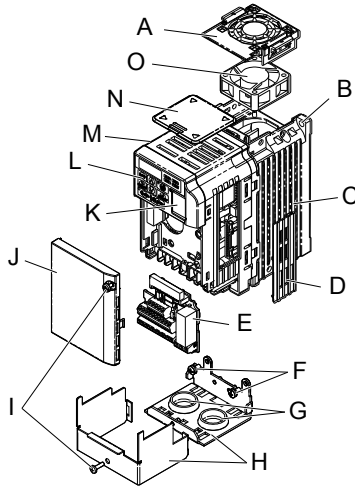

- |  |  |
|--|--|
| A – Fan cover <f>  | I – Front cover screws   |
| B – Mounting hole  | J – Front cover  |
| C – Heatsink   | K – Comm port  |
| D – Optional 24 V DC power supply connector cover                                      | L – LED operator <i>Refer to Using the Digital LED Operator on page 80</i> |
| E – Terminal board <i>Refer to Control Circuit Terminal Block Functions on page 65</i> | M – Case   |
| F – Bottom cover screws  | N – Top cover  |
| G – Rubber bushing   | O – Cooling fan <f>  |
| H – Bottom front cover   |  |

Figure 1.5 Exploded View of IP20/NEMA Type 1 Components  
Three-Phase AC200 V CIMR-V□2A0006F

- <1> The drives CIMR-V□BA0001F ~ 0003F and CIMR-V□2A0001F ~ 0004F do not have a cooling fan or a cooling fan cover.

- Single-Phase AC200 V CIMR-V□BA0006F ~ 0018F
- Three-Phase AC200 V CIMR-V□2A0010F~ 0020F
- Three-Phase AC400 V CIMR-V□4A0001F ~ 0011F

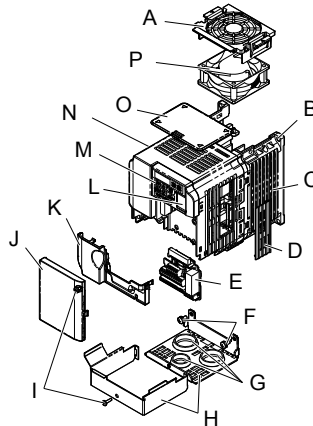

- |   |   |
|---|---|
| A – Fan cover <1>   | I – Front cover screws  |
| B – Mounting hole   | J – Front cover   |
| C – Heatsink  | K – Terminal cover  |
| D – Optional 24 V DC power supply connector cover   | L – Comm port   |
| E – Terminal board <a href="#">Refer to Control Circuit Terminal Block Functions on page 65</a> | M – LED operator <a href="#">Refer to Using the Digital LED Operator on page 80</a> |
| F – Cover screws  | N – Case  |
| G – Rubber bushing  | O – Top cover   |
| H – Bottom cover  | P – Cooling fan <1>   |

Figure 1.6 Exploded view of IP20/NEMA Type 1 Components  
Three-Phase AC200 V CIMR-V□2A0012F

- <1> The drives CIMR-V□BA0006B and CIMR-V□4A0001B ~ 0004B do not have a cooling fan or a cooling fan cover. The drive CIMR-V□BA0018B has two cooling fans.

## 1.2 Component Names

- Three-Phase AC200 V CIMR-V□2A0030F ~ 0069F  
Three-Phase AC400 V CIMR-V□4A00018F ~ 0038F

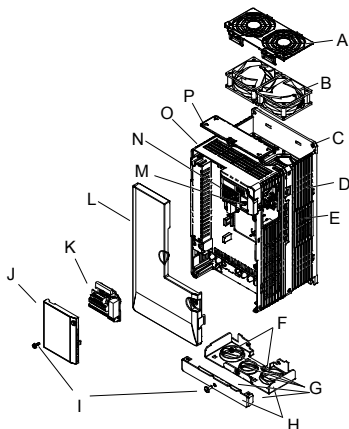

- |   |  |
|---|--|
| A – Fan cover   | I – Front cover screws   |
| B – Cooling fan                                       | J – Terminal cover   |
| C – Mounting Hole                                     | K – Terminal board <i>Refer to<br/>Control Circuit Terminal<br/>Block Functions on page<br/>65</i> |
| D – Case and Heatsink                                 | L – Front cover  |
| E – Optional 24 V DC power<br>supply connection cover | M – Comm port  |
| F – Cover screws                                      | N – LED operator <i>Refer to<br/>Using the Digital LED<br/>Operator on page 80</i>                 |
| G – Rubber bushing                                    | O – Case   |
| H – Bottom cover                                      | P – Top cover  |

Figure 1.7 Exploded View of IP20/NEMA Type 1 Components  
Three-Phase AC400 V CIMR-V□4A00018F

◆ Front Views

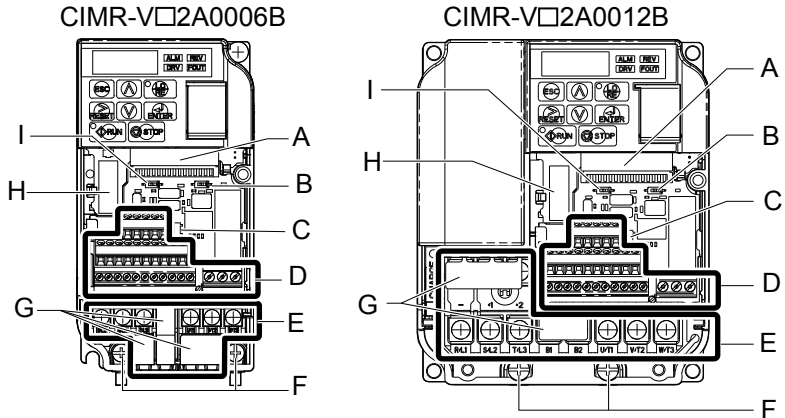

- A – Terminal board connector
- B – DIP switch S1 *Refer to DIP Switch S1 Analog Input Signal Selection on page 75*
- C – DIP switch S3 *Refer to Sinking/Sourcing Mode Switch on page 72*
- D – Control circuit terminal *Refer to Control Circuit Wiring on page 65*
- E – Main circuit terminal *Refer to Wiring the Main Circuit Terminal on page 64*

- F – Ground terminal
- G – Terminal cover
- H – Option card connector
- I – DIP switch S2

Figure 1.8 Front Views of Drives

**This Page Intentionally Blank**



# 2

[efesotomasyon.com](http://efesotomasyon.com)

---

## Mechanical Installation

---

This chapter explains how to properly mount and install the drive.

### 2.1 MECHANICAL INSTALLATION.....38

# 2.1 Mechanical Installation

This section outlines specifications, procedures, and environment for proper mechanical installation of the drive.

## ◆ Installation Environment

To help prolong the optimum performance life of the drive, install the drive in the proper environment. The table below provides a description of the appropriate environment for the drive.

**Table 2.1 Installation Environment**

Environment	Conditions
Installation Area	Indoors
Ambient Temperature	-10 °C to +40 °C (IP20/NEMA 1) -10 °C to +50 °C (IP20/Open-Chassis) Drive reliability improves in environments without wide temperature fluctuations. When using an enclosure panel, install a cooling fan or air conditioner in the area to ensure that the air temperature inside the enclosure does not exceed the specified levels. Do not allow ice to develop on the drive.
Humidity	95% RH or less and free of condensation
Storage Temperature	-20 °C to +60 °C
Surrounding Area	Install the drive in an area free from: <ul style="list-style-type: none"><li>• oil mist and dust</li><li>• metal shavings, oil, water or other foreign materials</li><li>• radioactive materials</li><li>• combustible materials (e.g., wood)</li><li>• harmful gases and liquids</li><li>• excessive vibration</li><li>• chlorides</li><li>• direct sunlight</li></ul>
Altitude	1000 m or lower
Vibration	10 to 20 Hz at 9.8 m/s <sup>2</sup> 20 to 55 Hz at 5.9 m/s <sup>2</sup>
Orientation	Install the drive vertically to maintain maximum cooling effects.

**NOTICE:** Prevent foreign matter such as metal shavings or wire clippings from falling into the drive during installation and project construction. Failure to comply could result in damage to the drive. Place a temporary cover over the top of the drive during installation. Remove the temporary cover before startup, as the cover will reduce ventilation and cause the drive to overheat.

**NOTICE:** Avoid placing drive peripheral devices, transformers, or other electronics near the drive. Failure to comply could result in erroneous operation. If such devices must be used in close proximity to the drive, take proper steps to shield the drive from noise.

## ◆ Installation Orientation and Spacing

Install the drive upright as illustrated in *Figure 2.1* to maintain proper cooling.

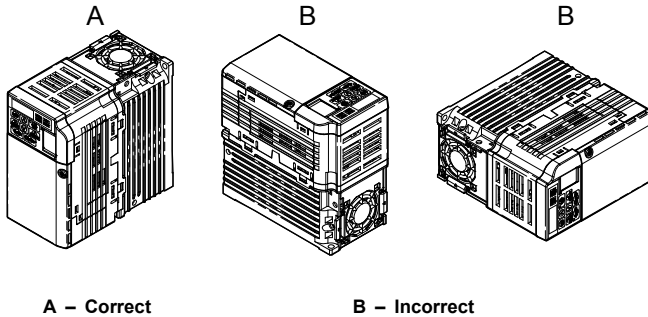

Figure 2.1 Correct Installation Orientation

## ■ Single Drive Installation

*Figure 2.2* explains the required installation spacing to maintain sufficient space for airflow and wiring. Install the heatsink against a closed surface to avoid diverting cooling air around the heatsink.

## 2.1 Mechanical Installation

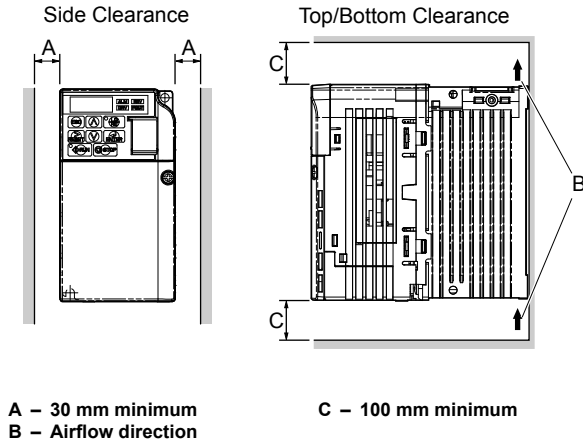
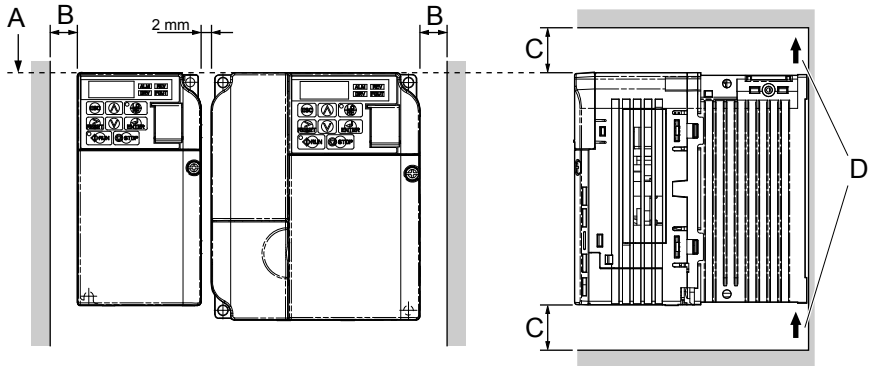

Figure 2.2 Correct Installation Spacing

**Note:** IP20/NEMA Type 1 and IP20/Open-Chassis models require the same amount of space above and below the drive for installation.

### ■ Multiple Drive Installation

When installing multiple drives into the same enclosure panel, mount the drives according to [Figure 2.2](#). When mounting drives with a minimum side-by-side clearance of 2 mm according to [Figure 2.3](#), derating must be considered and parameter L8-35 must be set. [Refer to Parameter List on page 157](#).



**A** – Line up the tops of the drives.

**B** – 30 mm minimum

**C** – 100 mm minimum

**D** – Airflow direction

**Figure 2.3 Space Between Drives (Side-by-Side Mounting)**

**Note:** When installing drives of different heights in the same enclosure panel, the tops of the drives should line up. Leave space between the top and bottom of stacked drives for cooling fan replacement if required. Using this method, it is possible to replace the cooling fans later.

**NOTICE:** When drives with IP20/NEMA Type 1 enclosures are mounted side by side, the top covers of all drives must be removed as shown in [Figure 2.4](#).

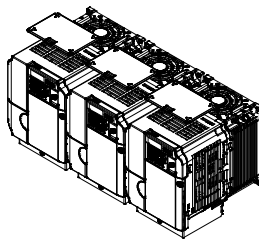

**Figure 2.4 IP20/NEMA 1 Side-by-Side Mounting in Enclosure**

## 2.1 Mechanical Installation

### ◆ Exterior and Mounting Dimensions

#### ■ IP20/Open-Chassis Drives

Table 2.2 IP20/Open-Chassis (without an EMC filter)

Voltage Class	Drive Model CIMR-V□	Dimensions (in)								
		W	H	D	W1	H1	H2	D1	t1	Wt. (lb.)
Single-Phase 200 V Class	BA0001B	2.68	5.04	2.99	2.20	4.65	0.20	0.26	0.12	1.3
	BA0002B	2.68	5.04	2.99	2.20	4.65	0.20	0.26	0.12	1.3
	BA0003B	2.68	5.04	4.65	2.20	4.65	0.20	1.52	0.20	2.2
Three-Phase 200 V Class	2A0001B	2.68	5.04	2.99	2.20	4.65	0.20	2.26	0.12	1.3
	2A0002B	2.68	5.04	2.99	2.20	4.65	0.20	2.26	0.12	1.3
	2A0004B	2.68	5.04	4.25	2.20	4.65	0.20	1.52	0.20	2.0
	2A0006B	2.68	5.04	5.04	2.20	4.65	0.20	2.30	0.20	2.4

**Table 2.3 IP20/Open-Chassis (without an EMC filter)**

Voltage Class	Drive Model CIMR-V□	Dimensions (in)								
		W	H	D	W1	H1	H2	D1	t1	Wt. (lb.)
Single-Phase 200 V Class	BA0006B	4.25	5.04	5.41	3.78	4.65	0.20	2.28	0.20	3.7
	BA0010B	4.25	5.04	6.06	3.78	4.65	0.20	2.28	0.20	4.0
	BA0012B	5.51	5.04	6.42	5.04	4.65	0.20	2.56	0.20	5.3
	BA0018B	6.69	5.04	7.09	6.22	4.65	0.20	2.56	0.20	6.6
Three-Phase 200 V Class	2A0010B	4.25	5.04	5.08	3.78	4.65	0.20	2.28	0.20	3.7
	2A0012B	4.25	5.04	5.41	3.78	4.65	0.20	2.28	0.20	3.7
	2A0020B	5.51	5.04	5.63	5.04	4.65	0.20	2.56	0.20	5.3
Three-Phase 400 V Class	4A0001B	4.25	5.04	3.19	3.78	4.65	0.20	0.39	0.20	2.2
	4A0002B	4.25	5.04	3.90	3.78	4.65	0.20	1.10	0.20	2.6
	4A0004B	4.25	5.04	5.41	3.78	4.65	0.20	2.28	0.20	3.7
	4A0005B	4.25	5.04	6.06	3.78	4.65	0.20	2.28	0.20	3.7
	4A0007B	4.25	5.04	6.06	3.78	4.65	0.20	2.28	0.20	3.7
	4A0009B	4.25	5.04	6.06	3.78	4.65	0.20	2.28	0.20	3.7
	4A0011B	5.51	5.04	5.63	5.04	4.65	0.20	2.56	0.20	5.3

## 2.1 Mechanical Installation

### ■ IP00/Open-Chassis Drives

Table 2.4 IP00/Open-Chassis (without an EMC filter)

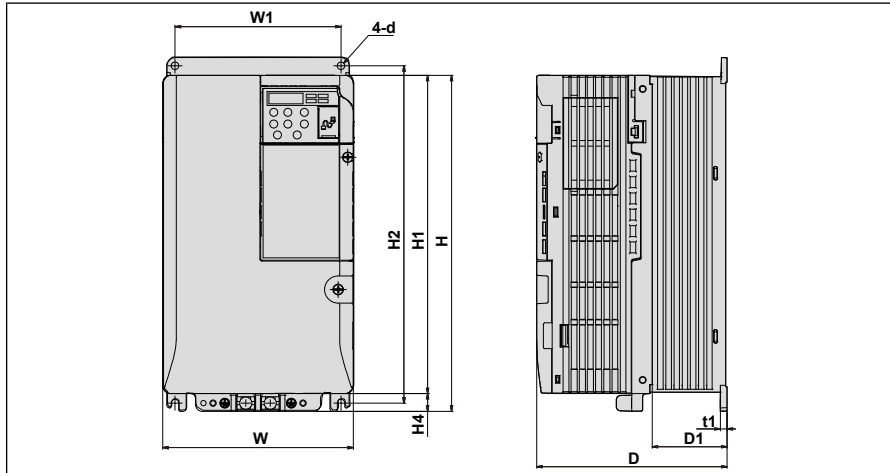

Voltage Class	Drive Model CIMR-V□	Dimensions (in)										
		W	H	D	W1	H1	H2	H4	D1	d	t1	Wt. (lb)
Three-Phase 200 V Class	2A0030A	5.5	9.7	5.5	4.8	9.2	9.8	0.5	2.2	M5	0.2	7.9
	2A0040A	5.5	9.7	5.5	4.8	9.2	9.8	0.5	2.2	M5	0.2	7.9
	2A0056A	7.1	11.2	6.4	6.3	10.6	11.2	0.6	3.0	M5	0.2	11.7
	2A0069A	8.7	13.2	7.4	7.6	12.6	13.2	0.6	3.1	M6	0.2	19.2
Three-Phase 400 V Class	4A0018A	5.5	9.7	5.5	4.8	9.2	9.8	0.5	2.2	M5	0.2	7.9
	4A0023A	5.5	9.7	5.5	4.8	9.2	9.8	0.5	2.2	M5	0.2	7.9
	4A0031A	7.1	11.2	5.6	6.3	10.6	11.2	0.6	2.2	M5	0.2	11.0
	4A0038A	7.1	11.2	6.4	6.3	10.6	11.2	0.6	3.0	M5	0.2	11.7

### ■ IP20/NEMA Type 1 Drives

Table 2.5 IP20/NEMA Type 1 (without an EMC filter)

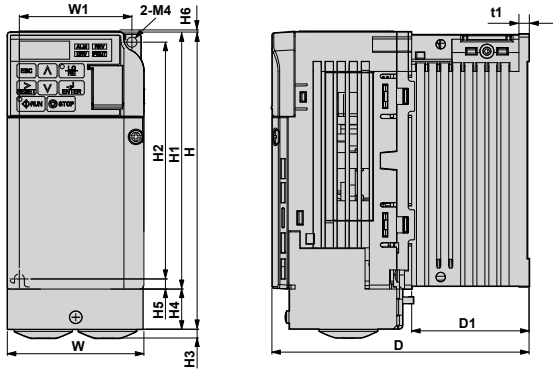

Voltage Class	Drive Model CIMR-V□	Dimensions (in)											Wt. (lb.)	
		W	H	D	W1	H1	H2	H3	H4	H5	H6	D1		t1
Single-Phase 200 V Class	BA0001F	2.68	5.89	2.99	2.20	5.03	4.65	0.16	0.79	0.20	0.06	0.26	0.12	1.8
	BA0002F	2.68	5.89	2.99	2.20	5.03	4.65	0.16	0.79	0.20	0.06	0.26	0.12	1.8
	BA0003F	2.68	5.89	4.65	2.20	5.03	4.65	0.16	0.79	0.20	0.06	1.54	0.20	2.6
Three-Phase 200 V Class	2A0001F	2.68	5.89	2.99	2.20	5.03	4.65	0.16	0.79	0.20	0.06	0.26	0.12	1.8
	2A0002F	2.68	5.89	2.99	2.20	5.03	4.65	0.16	0.79	0.20	0.06	0.26	0.12	1.8
	2A0004F	2.68	5.89	4.25	2.20	5.03	4.65	0.16	0.79	0.20	0.06	1.54	0.20	2.4
	2A0006F	2.68	5.89	5.04	2.20	5.03	4.65	0.16	0.79	0.20	0.06	2.32	0.20	2.9



## 2.1 Mechanical Installation

Table 2.7 IP20/NEMA Type 1 (without an EMC filter)

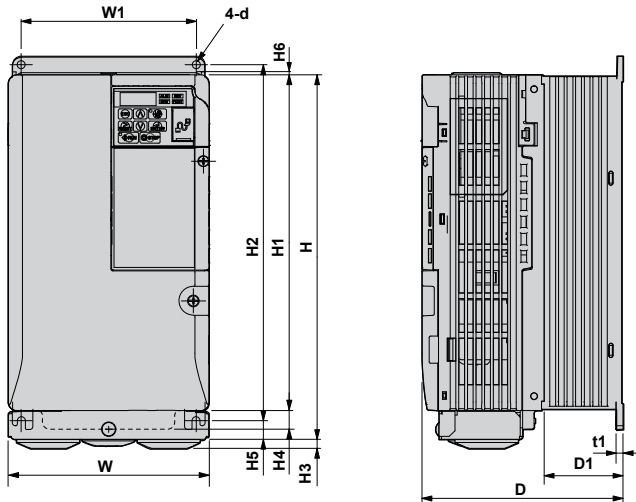

Voltage Class	Drive Model CIMR-V□	Dimensions (in)													Wt. (lb.)
		W	H	D	W1	H1	H2	H3	H4	H5	H6	D1	t1	d	
Three-Phase 200 V Class	2A0030F	5.51	10.00	5.51	4.80	9.21	9.76	0.24	0.51	0.51	0.06	2.17	0.20	M5	8.4
	2A0040F	5.51	10.00	5.51	4.80	9.21	9.76	0.24	0.51	0.51	0.06	2.17	0.20	M5	8.4
	2A0056F	7.09	11.42	6.42	6.30	10.63	11.18	0.24	0.59	0.51	0.06	2.95	0.20	M5	12.1
	2A0069F	8.66	13.78	7.36	7.56	12.60	13.23	0.28	0.59	0.87	0.06	3.07	0.20	M5	20.3
Three-Phase 400 V Class	4A0018F	5.51	10.00	5.51	4.80	9.21	9.76	0.24	0.51	0.51	0.06	2.17	0.20	M5	8.4
	4A0023F	5.51	10.00	5.51	4.80	9.21	9.76	0.24	0.51	0.51	0.06	2.17	0.20	M5	8.4
	4A0031F	7.09	11.42	5.63	6.30	10.63	11.18	0.24	0.59	0.51	0.06	2.17	0.20	M5	11.5
	4A0038F	7.09	11.42	6.42	6.30	10.63	11.18	0.24	0.51	0.51	0.06	2.95	0.20	M5	12.1

**This Page Intentionally Blank**



# 3

[efesotomasyon.com](http://efesotomasyon.com)

## Electrical Installation

This chapter explains proper procedures for wiring the control circuit terminals, motor and power supply.

<b>3.1</b>	<b>STANDARD CONNECTION DIAGRAM.....</b>	<b>50</b>
<b>3.2</b>	<b>TERMINAL BLOCK CONFIGURATION.....</b>	<b>53</b>
<b>3.3</b>	<b>PROTECTIVE COVERS.....</b>	<b>54</b>
<b>3.4</b>	<b>MAIN CIRCUIT WIRING.....</b>	<b>59</b>
<b>3.5</b>	<b>CONTROL CIRCUIT WIRING.....</b>	<b>65</b>
<b>3.6</b>	<b>I/O CONNECTIONS.....</b>	<b>72</b>
<b>3.7</b>	<b>MAIN FREQUENCY REFERENCE.....</b>	<b>75</b>
<b>3.8</b>	<b>WIRING CHECKLIST.....</b>	<b>77</b>

### 3.1 Standard Connection Diagram

Connect the drive and peripheral devices as shown in *Figure 3.1*. It is possible to run the drive via the digital operator without connecting digital I/O wiring. This section does not discuss drive operation; *Refer to Start-Up Programming & Operation on page 79* for instructions on operating the drive.

**NOTICE:** *Inadequate branch short circuit protection could result in damage to the drive. Install adequate branch circuit short circuit protection per applicable codes. The drive is suitable for circuits capable of delivering not more than 30,000 RMS symmetrical amperes, 240 Vac maximum (200 V Class) and 440 Vac maximum (400 V Class).*

**NOTICE:** *When the input voltage is 480 V or higher or the wiring distance is greater than 100 meters, pay special attention to the motor insulation voltage or use a drive duty motor. Failure to comply could lead to motor insulation breakdown.*

**NOTICE:** *Do not connect AC control circuit ground to drive enclosure. Improper drive grounding can cause control circuit malfunction.*

**NOTICE:** *The minimum load for the multi-function relay output MA-MB-MC is 10 mA. If a circuit requires less than 10 mA (reference value), connect it to a photocoupler output (P1, P2, PC). Improper application of peripheral devices could result in damage to the photocoupler output of the drive.*

### 3.1 Standard Connection Diagram

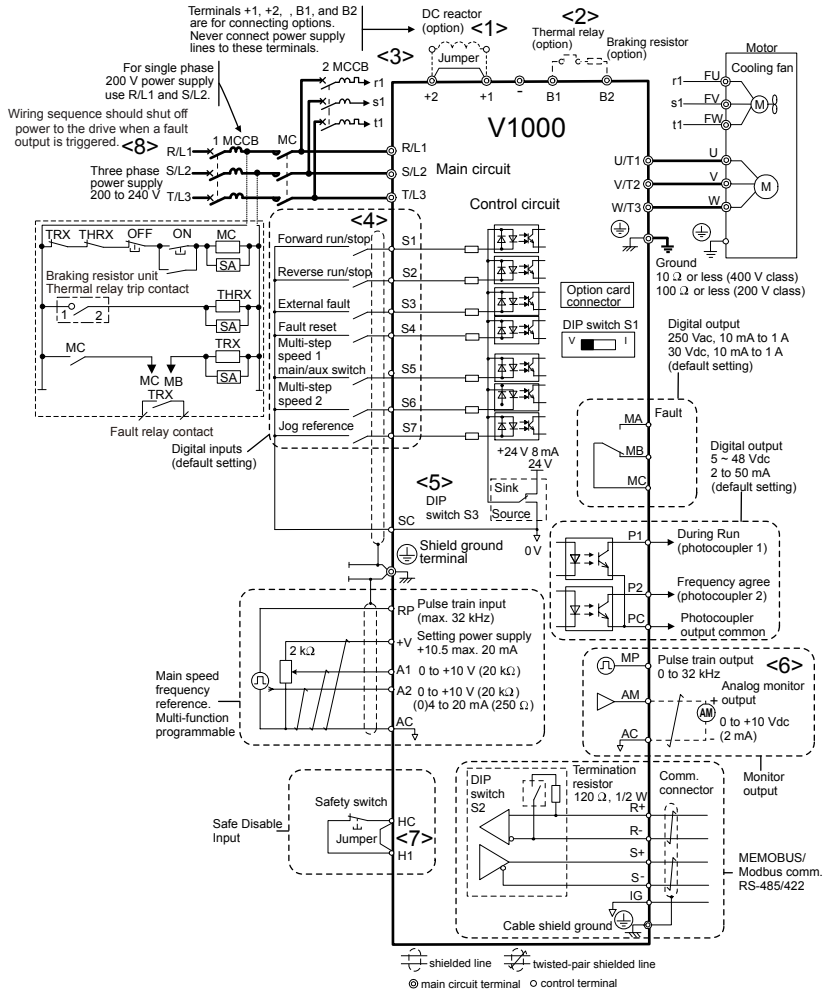

Figure 3.1 Drive Standard Connection Diagram

<1> Remove the jumper when installing an optional DC reactor.

## 3.1 Standard Connection Diagram

- <2> The MC on the input side of the main circuit should open when the thermal relay is triggered.
- <3> Self-cooled motors do not require separate cooling fan motor wiring.
- <4> Connected using sequence input signal (S1 to S7) from NPN transistor; Default: sink mode (0 V com).
- <5> Use only a +24 V internal power supply in sinking mode; the source mode requires an external power supply *Refer to I/O Connections on page 72.*
- <6> Monitor outputs work with devices such as analog frequency meters, ammeters, voltmeters and wattmeters; they are not intended for use as a feedback-type of signal.
- <7> Disconnect the wire jumper between HC and H1 when utilizing the safety input. *Refer to Wiring Procedure on page 70* for details on removing the jumper. The wire length for the Safe Disable input should not exceed 30 m.
- <8> Note that if the drive is set to trigger a fault output whenever the fault restart function is activated (L5-02 = 1), then a sequence to interrupt power when a fault occurs will result in shutting off the power to the drive as the drive attempts to restart itself. The default setting for L5-02 is 0 (fault output active during restart attempt).

**WARNING! Sudden Movement Hazard.** Do not close the wiring for the control circuit unless the multifunction input terminal parameter is properly set (S5 for 3-Wire; H1-05 = "0"). Improper sequencing of run/stop circuitry could result in death or serious injury from moving equipment.

**WARNING! Sudden Movement Hazard.** Ensure start/stop and safety circuits are wired properly and in the correct state before energizing the drive. Failure to comply could result in death or serious injury from moving equipment. When programmed for 3-Wire control, a momentary closure on terminal S1 may cause the drive to start.

**WARNING! When 3-Wire sequence is used, set the drive to 3-Wire sequence before wiring the control terminals and ensure parameter b1-17 is set to 0 (drive does not accept a run command at power up (default)). If the drive is wired for 3-Wire sequence but set up for 2-Wire sequence (default) and if parameter b1-17 is set to 1 (drive accepts a Run command at power up), the motor will rotate in reverse direction at power up of the drive and may cause injury.**

**WARNING! When the application preset function is executed (or A1-06 is set to any value other than 0) the drive I/O terminal functions change. This may cause unexpected operation and potential damage to equipment or injury.**

**Figure 3.2** illustrates an example of a 3-Wire sequence.

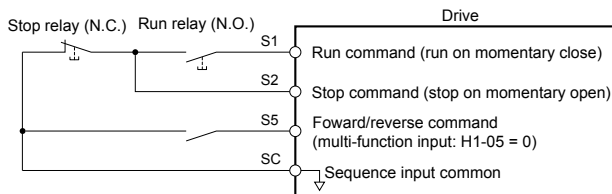

**Figure 3.2 3-Wire Sequence**

## 3.2 Terminal Block Configuration

The figures in this section provide illustrations of the main circuit terminal block configurations of the different drive sizes.

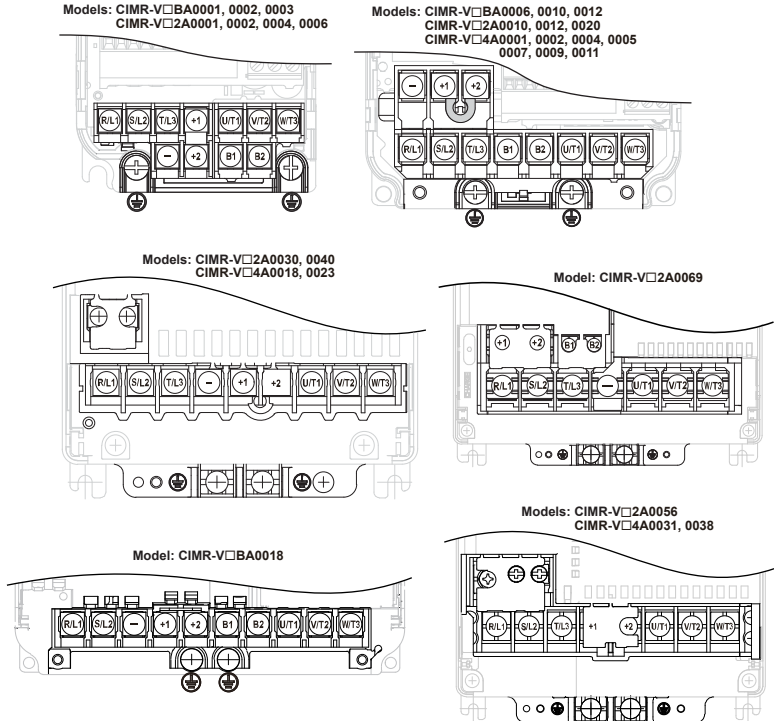

Figure 3.3 Main Circuit Terminal Block Configurations

### 3.3 Protective Covers

Follow the procedure below to remove the protective covers before wiring the drive and to reattach the covers after wiring is complete.

#### ◆ IP20/Open-Chassis Front and Bottom Cover Removal and Installation

##### ■ Removing the Protective Covers

1. Loosen the screw that locks the front cover in place to remove.

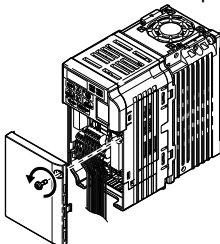

Figure 3.4 Remove the Front Cover on an IP20/Open-Chassis Drive

2. Apply pressure to the tabs on each side of the terminal cover. Pull the terminal cover away from the drive while pushing in on the tabs to pull the cover free.

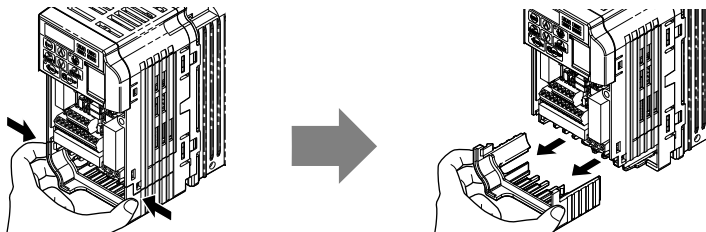

Figure 3.5 Remove the Terminal Cover on an IP20/Open-Chassis Drive

##### ■ Reattaching the Protective Covers

Properly connect all wiring and route power wiring away from control signal wiring. Reattach all protective covers when wiring is complete. Apply only a small amount of pressure to lock the cover back into place.

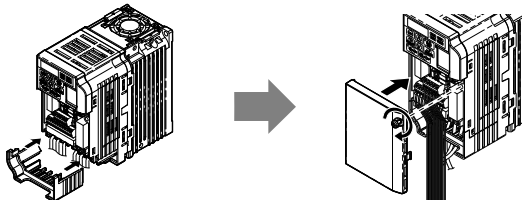

Figure 3.6 Reattach the Protective Covers on an IP20/Open-Chassis Drive

#### ◆ IP20/NEMA Type 1 Front and Bottom Cover Removal and Installation

##### ■ Removing the Protective Covers on an IP20/NEMA Type 1 Design

1. Loosen the screw on the front cover to remove the front cover.

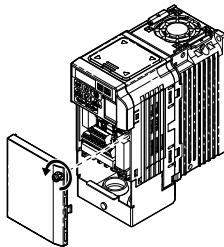
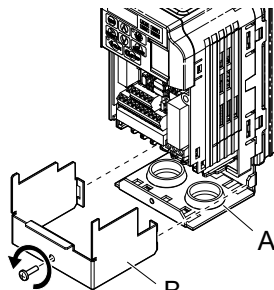

Figure 3.7 Remove the Front Cover on an IP20/NEMA Type 1 Drive

2. Loosen the screw on the terminal cover to remove the terminal cover and expose the conduit bracket.

### 3.3 Protective Covers



A – Conduit bracket

B – Terminal cover

Figure 3.8 Remove the Terminal Cover on an IP20/NEMA Type 1 Drive

3. Loosen two screws attaching the conduit bracket to remove.

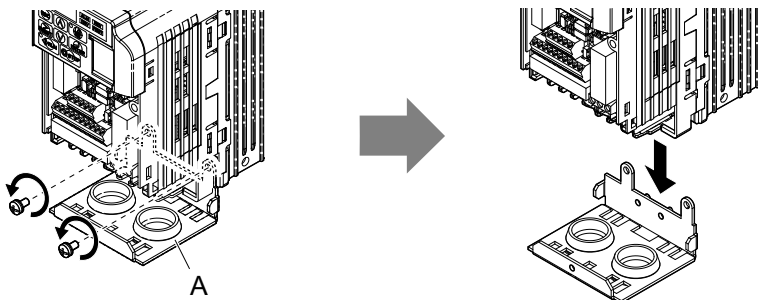

A – Conduit bracket

Figure 3.9 Remove the Conduit Bracket on an IP20/NEMA Type 1 Drive

### ■ Reattaching the Protective Covers

Pass power wiring and control signal wiring through the exit holes on the bottom of the conduit bracket of the drive. Place power wiring and control signal wiring in separate conduits. Properly connect all wiring after installing the drive and connecting other devices. Reattach all protective covers when wiring is complete.

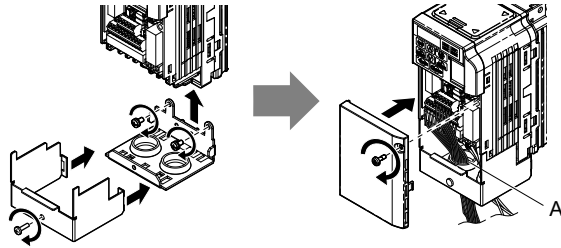

**A** – Pass power wiring and control signal wiring through different exit holes at the bottom of the drive.

**Figure 3.10** Reattach the Protective Covers and Conduit Bracket on an IP20/NEMA Type 1 Drive

## ◆ IP20/NEMA Type 1 Top Cover Removal and Installation

To improve the ambient temperature rating of a NEMA Type 1 drive from 40 °C to 50 °C or to mount NEMA Type 1 drives side-by-side, the top cover can be removed. Remove the top cover and set L8-35 to “2”.

**Note:** Removing the top cover of a NEMA Type 1 drive converts the drive to an IP20/Open-Chassis rating, and the drive will no longer have a NEMA Type 1 rating.

### ■ Removing the Top Cover

Insert the blade of a straight-edge screwdriver into the opening of the top cover. Gently lift up on the front cover as indicated by the arrow in [Figure 3.11](#) to remove it from the drive.

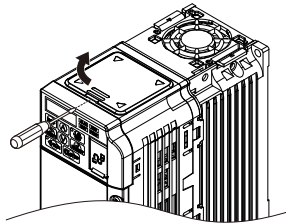

**Figure 3.11** Removing the Top Cover

### ■ Reattaching the Top Cover

Align the connection tabs on the underside of the top cover with the connection tabs on the drive. Pinch in on the top cover to click the cover into place on the drive.

### 3.3 Protective Covers

---

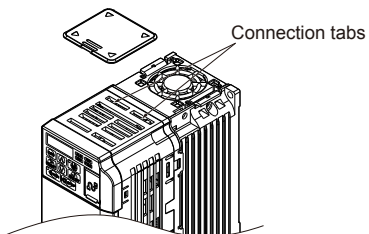

**Figure 3.12 Reattaching the Top Cover**

## 3.4 Main Circuit Wiring

This section describes the functions, specifications, and procedures required to safely and properly wire the main circuit of the drive.

**NOTICE:** Do not solder the ends of wire connections to the drive. Soldered wiring connections can loosen over time. Improper wiring practices could result in drive malfunction due to loose terminal connections.

### ◆ Main Circuit Terminal Functions

Table 3.1 Main Circuit Terminal Functions

Terminal	Type	Function	Reference
R/L1	Main circuit power supply input	Connects line power to the drive. Drives with single-phase 200 V input power use terminals R/L1 and S/L2 only (T/L3 must not be used).	–
S/L2			
T/L3			
U/T1	Drive output	Connects to the motor.	63
V/T2			
W/T3			
B1	Braking resistor	Available for connecting a braking resistor or the braking resistor unit option.	–
B2			
+1	DC reactor connection	These terminals are shorted at shipment. Remove the shorting bar between +1 and +2 when connecting a DC reactor to this terminal.	–
+2			
+1	DC power supply input	For connecting a DC power supply.	–
–			
 (2 terminals)	Ground	Grounding Terminal For 200 V class: 100 Ω or less For 400 V class: 10 Ω or less	63

### ◆ Wire Gauges and Tightening Torque

Select the appropriate wires and crimp terminals from [Table 3.2](#) through [Table 3.4](#).

- Note:**
- Wire gauge recommendations based on drive continuous current ratings using 75 °C 600 Vac vinyl-sheathed wire assuming ambient temperature within 30 °C and wiring distance less than 100 m.
  - Terminals +1, +2, –, B1 and B2 are for connecting optional devices such as a DC reactor or braking resistor. Do not connect other non-specified devices to these terminals.

- Consider the amount of voltage drop when selecting wire gauges. Increase the wire gauge when the voltage drop is greater than 2% of motor rated voltage. Ensure the wire gauge is suitable for the terminal block. Use the following formula to calculate the amount of voltage drop:

- Line drop voltage (V) =  $\sqrt{3}$  x wire resistance (Ω/km) x wire length (m) x current (A) x 10<sup>-3</sup>

## 3.4 Main Circuit Wiring

- Refer to instruction manual TOBPC72060000 for braking unit or braking resistor unit wire gauges.
- *Refer to UL Standards Compliance on page 200* for information on UL compliance.

### ■ Single-Phase 200 V Class

Table 3.2 Wire Gauge and Torque Specifications

Model CIMR- V□BA	Terminal	Screw Size	Tightening Torque N·m (lb.in.)	Applicable Gauge mm <sup>2</sup> (AWG)	Recommended Gauge mm <sup>2</sup> (AWG)
0001 0002 0003	R/L1, S/L2, U/T1, V/T2, W/T3, -, +1, +2, B1, B2, ⊕	M3.5	0.8 to 1.0 (7.1 to 8.9)	0.75 to 2.0 (18 to 14)	2 (14)
0006	R/L1, S/L2, U/T1, V/T2, W/T3, -, +1, +2, B1, B2, ⊕	M4	1.2 to 1.5 (10.6 to 13.3)	2.0 to 5.5 (14 to 10)	2 (14)
0010	R/L1, S/L2, U/T1, V/T2, W/T3, ⊕	M4	1.2 to 1.5 (10.6 to 13.3)	2.0 to 5.5 (14 to 10)	3.5 (12)
	-, +1, +2, B1, B2	M4	1.2 to 1.5 (10.6 to 13.3)	2.0 to 5.5 (14 to 10)	5.5 (10)
0012	R/L1, S/L2, U/T1, V/T2, W/T3, -, +1, +2, B1, B2, ⊕	M4	1.2 to 1.5 (10.6 to 13.3)	2.0 to 5.5 (14 to 10)	5.5 (10)
0018	R/L1, S/L2, U/T1, V/T2, W/T3, -, +1, +2, B1, B2, ⊕	M5	2 to 2.5 (17.7 to 22.1)	3.5 to 8 (12 to 8)	8 (8)

### ■ Three-Phase 200 V Class

Table 3.3 Wire Gauge and Torque Specifications

Model CIMR- V□2A	Terminal	Screw Size	Tightening Torque N·m (lb.in.)	Applicable Gauge mm <sup>2</sup> (AWG)	Recommended Gauge mm <sup>2</sup> (AWG)
0001 0002 0004 0006	R/L1, S/L2, T/L3, U/T1, V/T2, W/ T3, -, +1, +2, B1, B2, ⊕	M3.5	0.8 to 1.0 (7.1 to 8.9)	0.75 to 2.0 (18 to 14)	2 (14)
0010	R/L1, S/L2, T/L3, U/T1, V/T2, W/ T3, -, +1, +2, B1, B2	M4	1.2 to 1.5 (10.6 to 13.3)	2.0 to 5.5 (14 to 10)	2 (14)
	⊕	M4	1.2 to 1.5 (10.6 to 13.3)	2.0 to 5.5 (14 to 10)	3.5 (12)
0012	R/L1, S/L2, T/L3, U/T1, V/T2, W/ T3, -, +1, +2, B1, B2, ⊕	M4	1.2 to 1.5 (10.6 to 13.3)	2.0 to 5.5 (14 to 10)	3.5 (12)
0020	R/L1, S/L2, T/L3, U/T1, V/T2, W/ T3, -, +1, +2, B1, B2, ⊕	M4	1.2 to 1.5 (10.6 to 13.3)	2.0 to 5.5 (14 to 10)	5.5 (10)

Model CIMR-V□2A	Terminal	Screw Size	Tightening Torque N·m (lb.in.)	Applicable Gauge mm <sup>2</sup> (AWG)	Recommended Gauge mm <sup>2</sup> (AWG)
0030	R/L1, S/L2, T/L3, U/T1, V/T2, W/T3, -, +1, +2	M4	1.2 to 1.5 (10.6 to 13.3)	5.5 to 14 (10 to 6)	8 (8)
	B1, B2	M4	1.2 to 1.5 (10.6 to 13.3)	2.0 to 5.5 (14 to 10)	5.5 (10)
	⊕	M5	2 to 2.5 (17.7 to 22.1)	5.5 to 14 (10 to 6)	8 (8)
0040	R/L1, S/L2, T/L3, U/T1, V/T2, W/T3, -, +1, +2	M4	1.2 to 1.5 (10.6 to 13.3)	5.5 to 14 (10 to 6)	14 (6)
	B1, B2	M4	1.2 to 1.5 (10.6 to 13.3)	2.0 to 5.5 (14 to 10)	5.5 (10)
	⊕	M5	2 to 2.5 (17.7 to 22.1)	5.5 to 14 (10 to 6)	8 (8)
0056	R/L1, S/L2, T/L3, U/T1, V/T2, W/T3, -, +1, +2	M6	4 to 6 (35.4 to 53.1)	14 to 22 (6 to 4)	22 (4)
	B1, B2	M5	2 to 2.5 (17.7 to 22.1)	5.5 to 8 (10 to 8)	8 (8)
	⊕	M6	4 to 6 (35.4 to 53.1)	14 to 22 (6 to 4)	22 (4)
0069	R/L1, S/L2, T/L3, U/T1, V/T2, W/T3, -, +1, +2	M8	9 to 11 (79.7 to 11.0)	8 to 38 (8 to 2)	38 (2)
	B1, B2	M5	2 to 2.5 (17.7 to 22.1)	8 to 14 (8 to 6)	14 (6)
	⊕	M6	4 to 6 (35.4 to 53.1)	8 to 22 (8 to 4)	22 (4)

### ■ Three-Phase 400 V Class

Table 3.4 Wire Gauge and Torque Specifications

Model CIMR-V□4A	Terminal	Screw Size	Tightening Torque N·m (lb.in.)	Applicable Gauge mm <sup>2</sup> (AWG)	Recommended Gauge mm <sup>2</sup> (AWG)
0001 0002 0004 0005 0007	R/L1, S/L2, T/L3, U/T1, V/T2, W/T3, -, +1, +2, B1, B2, ⊕	M4	1.2 to 1.5 (10.6 to 13.3)	2.0 to 5.5 (14 to 10)	2 (14)
0009	R/L1, S/L2, T/L3, U/T1, V/T2, W/T3, -, +1, +2, B1, B2	M4	1.2 to 1.5 (10.6 to 13.3)	2.0 to 5.5 (14 to 10)	2 (14)
	⊕	M4	1.2 to 1.5 (10.6 to 13.3)	2.0 to 5.5 (14 to 10)	3.5 (12)

### 3.4 Main Circuit Wiring

Model CIMR- V□4A	Terminal	Screw Size	Tightening Torque N·m (lb.in.)	Applicable Gauge mm <sup>2</sup> (AWG)	Recommended Gauge mm <sup>2</sup> (AWG)
0011	R/L1, S/L2, T/L3, U/T1, V/T2, W/ T3, -, +1, +2, B1, B2	M4	1.2 to 1.5 (10.6 to 13.3)	2.0 to 5.5 (14 to 10)	2 (14)
	⊕	M4	1.2 to 1.5 (10.6 to 13.3)	2.0 to 5.5 (14 to 10)	3.5 (12)
0018	R/L1, S/L2, T/L3, U/T1, V/T2, W/ T3, -, +1, +2, B1, B2	M4	1.2 to 1.5 (10.6 to 13.3)	2.0 to 5.5 (14 to 10)	5.5 (10)
	⊕	M5	2 to 2.5 (17.7 to 22.1)	5.5 to 14 (10 to 6)	5.5 (10)
0023	R/L1, S/L2, T/L3, U/T1, V/T2, W/ T3, -, +1, +2	M4	1.2 to 1.5 (10.6 to 13.3)	5.5 to 14 (10 to 6)	8 (8)
	B1, B2	M4	1.2 to 1.5 (10.6 to 13.3)	2.0 to 5.5 (14 to 10)	5.5 (10)
	⊕	M5	2 to 2.5 (17.7 to 22.1)	5.5 to 14 (10 to 6)	5.5 (10)
0031	R/L1, S/L2, T/L3, U/T1, V/T2, W/ T3, -, +1, +2	M5	2 to 2.5 (17.7 to 22.1)	5.5 to 14 (10 to 6)	8 (8)
	B1, B2	M5	2 to 2.5 (17.7 to 22.1)	5.5 to 8 (10 to 8)	8 (8)
	⊕	M6	4 to 6 (35.4 to 53.1)	5.5 to 14 (10 to 6)	8 (8)
0038	R/L1, S/L2, T/L3, U/T1, V/T2, W/ T3, -, +1, +2	M5	2 to 2.5 (17.7 to 22.1)	5.5 to 14 (10 to 6)	14 (6)
	B1, B2	M5	2 to 2.5 (17.7 to 22.1)	5.5 to 8 (10 to 8)	8 (8)
	⊕	M6	4 to 6 (35.4 to 53.1)	5.5 to 14 (10 to 6)	8 (8)

### ◆ Main Circuit Terminal Power Supply and Motor Wiring

This section outlines the various steps, precautions, and checkpoints for wiring the main circuit terminals and motor terminals.

**NOTICE:** When connecting the motor to the drive output terminals U/T1, V/T2, and W/T3, the phase order for the drive and motor should match. Failure to comply with proper wiring practices may cause the motor to run in reverse if the phase order is backward.

**NOTICE:** Do not connect phase-advancing capacitors or LC/RC noise filters to the output circuits. Improper application of noise filters could result in damage to the drive.

**NOTICE:** Do not connect the AC power line to the output motor terminals of the drive. Failure to comply could result in death or serious injury by fire as a result of drive damage from line voltage application to output terminals.

## ■ Cable Length Between Drive and Motor

When the cable length between the drive and the motor is too long (especially at low frequency output), note that the cable voltage drop may cause reduced motor torque. Drive output current will increase as the leakage current from the cable increases. An increase in leakage current may trigger an overcurrent situation and weaken the accuracy of the current detection.

Adjust the drive carrier frequency according to the following table. If the motor wiring distance exceeds 100 m because of the system configuration, reduce the ground currents.

Refer to [Table 3.5](#) to set the carrier frequency to an appropriate level.

**Table 3.5 Cable Length Between Drive and Motor**

Cable Length	50 m or less	100 m or less	Greater than 100 m
Carrier Frequency	15 kHz or less	5 kHz or less	2 kHz or less

**Note:** When setting carrier frequency, calculate the cable length as the total distance of wiring to all connected motors when running multiple motors from a single drive.

## ■ Ground Wiring

Follow the precautions to wire the ground for one drive or a series of drives.

**WARNING!** *Electrical Shock Hazard.* Always use a ground wire that complies with technical standards on electrical equipment and minimize the length of the ground wire. Improper equipment grounding may cause dangerous electrical potentials on equipment chassis, which could result in death or serious injury.

**WARNING!** *Electrical Shock Hazard.* Be sure to ground the drive ground terminal. (200 V Class: Ground to 100  $\Omega$  or less, 400 V Class: Ground to 10  $\Omega$  or less). Improper equipment grounding could result in death or serious injury by contacting ungrounded electrical equipment.

**NOTICE:** Do not share the ground wire with other devices such as welding machines or large-current electrical equipment. Improper equipment grounding could result in drive or equipment malfunction due to electrical interference.

**NOTICE:** When using more than one drive, ground multiple drives according to instructions. Improper equipment grounding could result in abnormal operation of drive or equipment.

Refer to [Figure 3.13](#) when using multiple drives. Do not loop the ground wire.

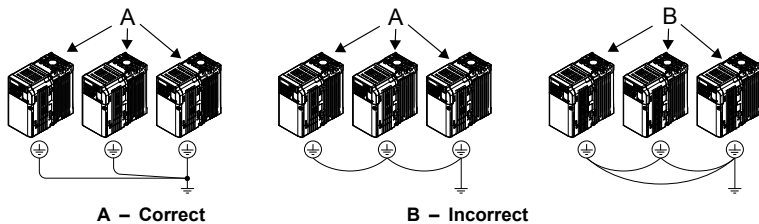

**Figure 3.13 Multiple Drive Wiring**

## 3.4 Main Circuit Wiring

---

### ■ Wiring the Main Circuit Terminal

**WARNING!** *Electrical Shock Hazard. Shut off the power supply to the drive before wiring the main circuit terminals. Failure to comply may result in death or serious injury.*

**Note:** A cover placed over the DC Bus and braking circuit terminals prior to shipment helps prevent miswiring. Cut away covers as needed for terminals with a needle-nose pliers.

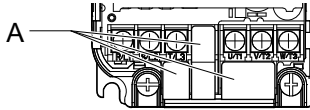

**A – Protective Cover to Prevent Miswiring**

**Note:** The ground terminal screw on IP20/NEMA Type 1 holds the protective cover in place.

## 3.5 Control Circuit Wiring

### ◆ Control Circuit Terminal Block Functions

Drive parameters determine which functions apply to the multi-function digital inputs (S1 to S7), multi-function digital outputs (MA, MB), multi-function pulse inputs and outputs (RP, MP) and multi-function photocoupler outputs (P1, P2). The default is called out next to each terminal in [Figure 3.1](#).

**WARNING!** Sudden Movement Hazard. Always check the operation and wiring of control circuits after being wired. Operating a drive with untested control circuits could result in death or serious injury.

**WARNING!** Confirm the drive I/O signals and external sequence before starting test run. Setting parameter A1-06 may change the I/O terminal function automatically from the factory setting. [Refer to Application Selection on page 93](#). Failure to comply may result in death or serious injury.

### ■ Input Terminals

Table 3.6 Control Circuit Input Terminals

Type	No.	Terminal Name (Function)	Function (Signal Level) Default Setting
Multi-Function Digital Inputs	S1	Multi-function input 1 (Closed: Forward run, Open: Stop)	Photocoupler 24 Vdc, 8 mA <b>Note:</b> Drive preset to sinking mode. When using source mode, set DIP switch S3 to allow for a 24 Vdc ( $\pm 10\%$ ) external power supply. <a href="#">Refer to Sinking/Sourcing Mode Switch on page 72</a> .
	S2	Multi-function input 2 (Closed: Reverse run, Open: Stop)	
	S3	Multi-function input 3 (External fault (N.O.))	
	S4	Multi-function input 4 (Fault reset)	
	S5	Multi-function input 5 (Multi-step speed reference 1)	
	S6	Multi-function input 6 (Multi-step speed reference 2)	
	S7	Multi-function input 7 (Jog reference)	
	SC	Multi-function input common (Control common)	Sequence common
Safe Disable Input	HC	Power supply for safe disable input	+24 Vdc (max 10 mA allowed)
	H1	Safe disable input	Open: Output disabled Closed: Normal operation <b>Note:</b> Disconnect wire jumper between HC and H1 when using the safe disable input. The wire length should not exceed 30 m.

## 3.5 Control Circuit Wiring

Type	No.	Terminal Name (Function)	Function (Signal Level) Default Setting
Main Frequency Reference Input	RP	Multi-function pulse train input (frequency reference)	Response frequency: 0.5 to 32 kHz (Duty Cycle: 30 to 70%) (High level voltage: 3.5 to 13.2 Vdc) (Low level voltage: 0.0 to 0.8 Vdc) (input impedance: 3 kΩ)
	+V	Analog input power supply	+10.5 Vdc (max allowable current 20 mA)
	A1	Multi-function analog input 1 (frequency reference)	Input voltage 0 to +10 Vdc (20 kΩ) resolution 1/1000
	A2	Multi-function analog input 2 (frequency reference)	Input voltage or input current (Selected by DIP switch S1 and H3-01) 0 to +10 Vdc (20 kΩ), Resolution: 1/1000 4 to 20 mA (250 Ω) or 0 to 20 mA (250 Ω), Resolution: 1/500
	AC	Frequency reference common	0 Vdc

## ■ Output Terminals

Table 3.7 Control Circuit Output Terminals

Type	No.	Terminal Name (Function)	Function (Signal Level) Default Setting
Multi-Function Digital Output <1>	MA	N.O. (fault)	Digital output 30 Vdc, 10 mA to 1 A; 250 Vac, 10 mA to 1 A Minimum load: 5 Vdc, 10 mA (reference value)
	MB	N.C. output (fault)	
	MC	Digital output common	
Multi-Function Photocoupler Output	P1	Photocoupler output 1 (During run)	Photocoupler output 48 Vdc, 2 to 50 mA <2>
	P2	Photocoupler output 2 (Frequency agree)	
	PC	Photocoupler output common	
Monitor Output	MP	Pulse train output (Output frequency)	32 kHz (max) <3> <4>
	AM	Analog monitor output	0 to 10 Vdc (2 mA or less) Resolution: 1/1000
	AC	Monitor common	0 V

- <1> Do not assign functions to digital relay outputs that involve frequent switching. This may shorten relay performance life. Switching life is estimated at 200,000 times (assumes 1 A, resistive load).
- <2> Connect a suppression diode as shown in [Figure 3.14](#) when driving a reactive load such as a relay coil. Ensure the diode rating is greater than the circuit voltage.
- <3> When set for sourcing, +5 V/1.5 kΩ or higher, +8 V/3.5 kΩ or higher, +10 V/10 kΩ or higher.
- <4> When set for sinking, the external power supply should be +12 Vdc, ±5% with 16 mA or less.

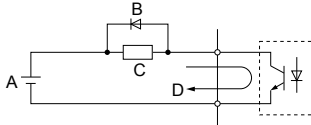

- A** – External power, 48 V max.      **C** – Coil  
**B** – Suppression diode                **D** – 50 mA or less

**Figure 3.14 Connecting a Suppression Diode**

### ■ Serial Communication Terminals

**Table 3.8 Control Circuit Terminals: Serial Communications**

Type	No.	Signal Name	Function (Signal Level)	
MEMOBUS/ Modbus Communication	R+	Communications input (+)	MEMOBUS/Modbus communication: Use a RS-485 or RS-422 cable to connect the drive.	RS-485/422 MEMOBUS/Modbus communication protocol 115.2 kbps (max.)
	R-	Communications input (-)		
	S+	Communications output (+)		
	S-	Communications output (-)		
	IG	Shield ground	0 V	

### ◆ Terminal Configuration

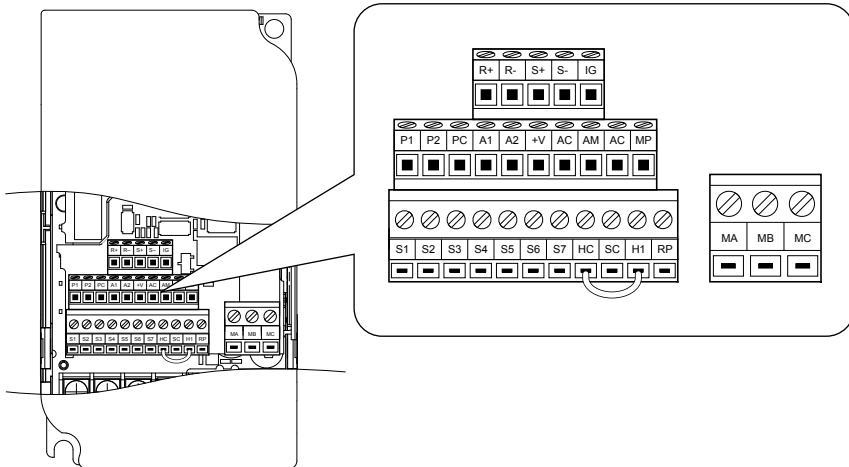

Figure 3.15 Removable Control Circuit Terminal Block  
(CIMR-VA□□□□□□□□; CIMR-VU□□□□□□□□)

### ■ Wire Size and Torque Specifications

Select appropriate wire type and size from [Table 3.9](#). For simpler and more reliable wiring, crimp ferrules to the wire ends. Refer to [Table 3.10](#) for ferrule terminal types and sizes.

**Table 3.9 Wire Size and Torque Specifications (Same for All Models)**

Terminal	Screw Size	Tightening Torque N·m	Tightening Torque (in-lbs)	Bare Wire Terminal		Ferrule-Type Terminal		Wire Type
				Applic. wire size mm <sup>2</sup> (AWG)	Recomm. mm <sup>2</sup> (AWG)	Applic. wire size mm <sup>2</sup> (AWG)	Recomm. mm <sup>2</sup> (AWG)	
MA, MB, MC	M3	0.5 to 0.6	4.4 to 5.3	Stranded: 0.25 to 1.5 (24 to 16) Single: 0.25 to 1.5 (24 to 16)	0.75 (18)	0.25 to 1.0 (24 to 17)	0.5 (20)	Shielded line, etc.
S1-S7, SC, RP, +V, A1, A2, AC, HC, H1, P1, P2, PC, MP, AM, AC, S+, S-, R+, R-, IG	M2	0.22 to 0.25	1.9 to 2.2	Stranded: 0.25 to 1.0 (24 to 18) Single: 0.25 to 1.5 (24 to 16)	0.75 (18)	0.25 to 0.5 (24 to 20)	0.5 (20)	

#### ■ Ferrule-Type Wire Terminations

Crimp a ferrule to signal wiring to improve wiring simplicity and reliability. Use CRIMPFOX ZA-3, a crimping tool manufactured by PHOENIX CONTACT.

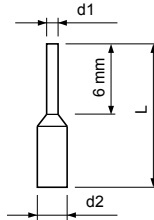

**Figure 3.16 Ferrule Dimensions**

**Table 3.10 Ferrule Terminal Types and Sizes**

Size mm <sup>2</sup> (AWG)	Type	L (mm)	d1 (mm)	d2 (mm)	Manufacturer
0.25 (24)	AI 0.25-6YE	10.5	0.8	2.0	PHOENIX CONTACT
0.34 (22)	AI 0.34-6TQ	10.5	0.8	2.0	
0.5 (20)	AI 0.5-6WH	12	1.1	2.5	
0.75 (18)	AI 0.75-6GY	12	1.3	2.8	
1.0	AI 1-6RD	12	1.5	3.0	

## 3.5 Control Circuit Wiring

---

### ◆ Wiring Procedure

This section describes the proper procedures and preparations for wiring the control terminals.

**WARNING!** *Electrical Shock Hazard. Do not remove covers or touch the circuit boards while the power is on. Failure to comply could result in death or serious injury.*

**NOTICE:** *Separate control circuit wiring from main circuit wiring (terminals R/L1, S/L2, T/L3, B1, B2, U/T1, V/T2, W/T3, -, +1, +2) and other high-power lines. Improper wiring practices could result in drive malfunction due to electrical interference.*

**NOTICE:** *Separate wiring for digital output terminals MA, MB and MC from wiring to other control circuit lines. Improper wiring practices could result in drive or equipment malfunction or nuisance trips.*

**NOTICE:** *Use a class 2 power supply (UL standard) when connecting to the control terminals. Improper application of peripheral devices could result in drive performance degradation due to improper power supply.*

**NOTICE:** *Insulate shields with tape or shrink tubing to prevent contact with other signal lines and equipment. Improper wiring practices could result in drive or equipment malfunction due to short circuit.*

**NOTICE:** *Connect the shield of shielded cable to the appropriate ground terminal. Improper equipment grounding could result in drive or equipment malfunction or nuisance trips.*

Wire the control terminals using [Figure 3.17](#) as a guide. Prepare the ends of the control circuit wiring as shown in [Figure 3.18](#). [Refer to Wire Size and Torque Specifications on page 68](#).

**NOTICE:** *Do not tighten screws beyond the specified tightening torque. Failure to comply may damage the terminal block.*

**NOTICE:** *Use shielded twisted-pair cables as indicated to prevent operating faults. Improper wiring practices could result in drive or equipment malfunction due to electrical interference.*

Connect control wires as shown in the following figure:

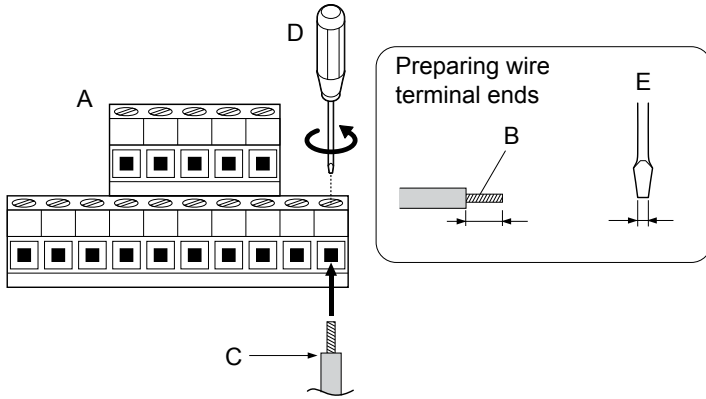

- |  |  |
|--|--|
| <p><b>A</b> – Control terminal block</p> <p><b>B</b> – Avoid fraying wire strands when stripping insulation from wire.<br/>Strip length 5.5 mm.</p> <p><b>C</b> – Single wire or stranded wire</p> | <p><b>D</b> – Loosen screw to insert wire.</p> <p><b>E</b> – Blade depth of 0.4 mm or less<br/>Blade width of 2.5 mm or less</p> |
|--|--|

**Figure 3.17 Terminal Board Wiring Guide**

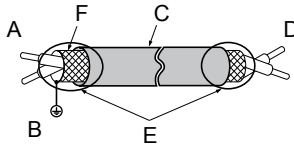

- |   |   |
|---|---|
| <p><b>A</b> – Drive side</p> <p><b>B</b> – Connect shield to ground terminal of drive.</p> <p><b>C</b> – Insulation</p> | <p><b>D</b> – Control device side</p> <p><b>E</b> – Shield sheath (Insulate with tape)</p> <p><b>F</b> – Shield</p> |
|---|---|

**Figure 3.18 Preparing the Ends of Shielded Cables**

## 3.6 I/O Connections

### ◆ Sinking/Sourcing Mode Switch

Set the DIP switch S3 on the front of the drive to switch the digital input terminal logic between sinking mode and sourcing mode; the drive is preset to sinking mode.

**Table 3.11 Sinking/Sourcing Mode Setting**

Set Value	Details
SINK	Sinking Mode (0 V common): default setting
SOURCE	Sourcing Mode (+24 V common)

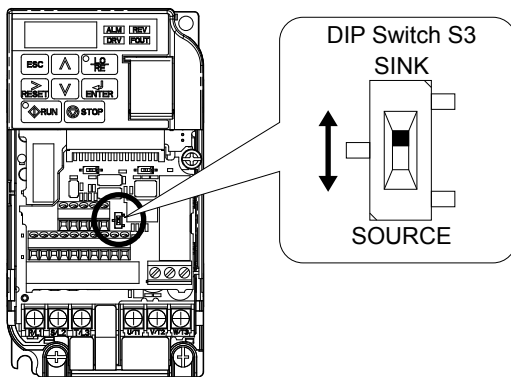

**Figure 3.19 DIP Switch S3**

### ■ Transistor Input Signal Using 0 V Common/Sink Mode

When controlling the digital inputs by NPN transistors (0 V common/sinking mode), set the DIP switch S3 to SINK and use the internal 24 V power supply.

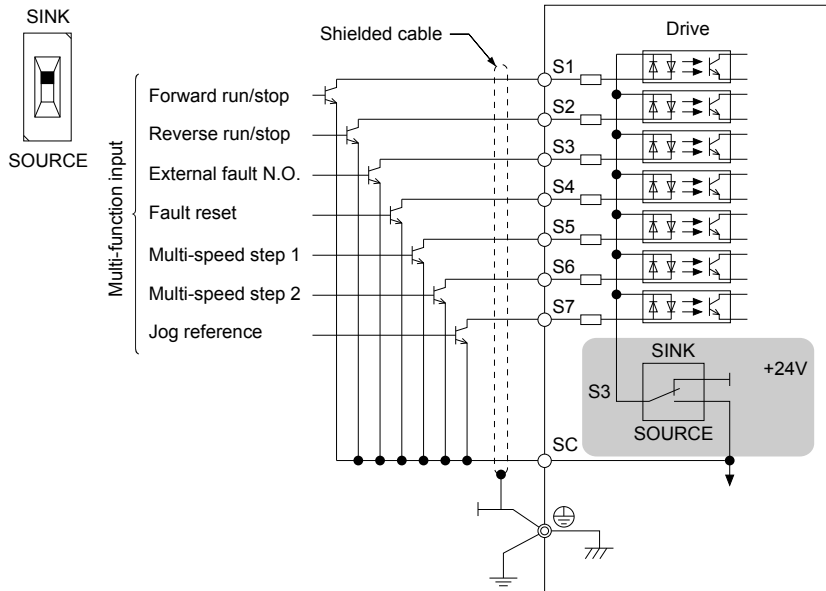

Figure 3.20 Sinking Mode: Sequence from NPN Transistor (0 V Common)

### ■ Transistor Input Signal Using +24 V Common/Source Mode

When controlling digital inputs by PNP transistors (+24 V common/sourcing mode), set the DIP switch S3 to SOURCE and use an external 24 V power supply.

### 3.6 I/O Connections

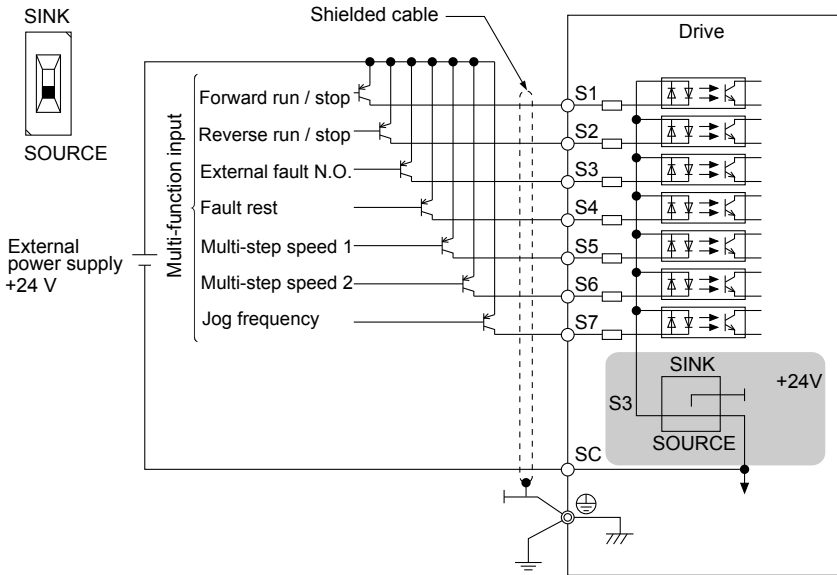

Figure 3.21 Source Mode: Sequence from PNP Transistor (+24 V Common)

## 3.7 Main Frequency Reference

### ◆ DIP Switch S1 Analog Input Signal Selection

The main frequency reference can either be a voltage or current signal input. For voltage signals both analog inputs, A1 and A2, can be used, for current signals A2 must be used.

When using input A2 as a voltage input, set DIP switch S1 to "V" (left position) and program parameter H3-09 to "0" (0 to +10 Vdc with lower limit) or "1" (0 to +10 Vdc without lower limit).

To use current input at terminal A2, set the DIP switch S1 to "I" (default setting) and set parameter H3-09 = "2" or "3" (4-20 mA or 0-20 mA). Set parameter H3-10 = "0" (frequency reference).

**Note:** If Terminals A1 and A2 are both set for frequency reference (H3-02 = 0 and H3-10 = 0), the addition of both input values builds the frequency reference.

**Table 3.12 Frequency Reference Configurations**

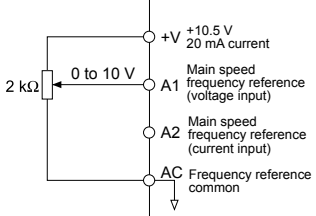
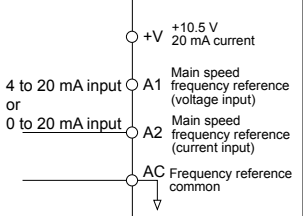
Voltage Input	Current Input
<p style="text-align: center;">Drive</p> 	<p style="text-align: center;">Drive</p> 

## 3.7 Main Frequency Reference

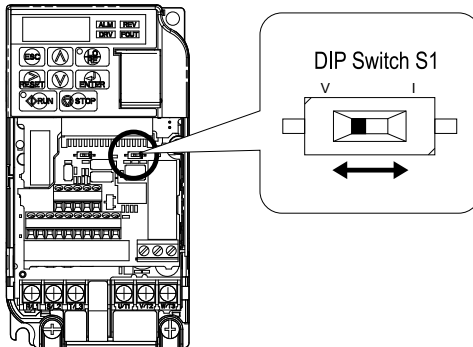

Figure 3.22 DIP Switch S1

Table 3.13 DIP Switch S1 Settings

Setting Value	Description
V (left position)	Voltage input (0 to 10 V)
I (right position)	Current input (4 to 20 mA or 0 to 20 mA): default setting

Table 3.14 Parameter H3-09 Details

No.	Parameter Name	Description	Setting Range	Default Setting
H3-09	Frequency ref. (current) terminal A2 signal level selection	Selects the signal level for terminal A2. 0: 0 to +10 V, unipolar input (with lower limit) 1: 0 to +10 V, bipolar input (no lower limit) 2: 4 to 20 mA 3: 0 to 20 mA	0 to 3	2

## 3.8 Wiring Checklist

<input checked="" type="checkbox"/>	No.	Item	Page
<b>Drive, peripherals, option cards</b>			
<input type="checkbox"/>	1	Check drive model number to ensure receipt of correct model.	26
<input type="checkbox"/>	2	Check for correct braking resistors, DC reactors, noise filters, and other peripheral devices.	-
<input type="checkbox"/>	3	Check for correct option card model.	-
<b>Installation area and physical setup</b>			
<input type="checkbox"/>	4	Ensure area surrounding the drive complies with specifications.	38
<b>Power supply voltage, output voltage</b>			
<input type="checkbox"/>	5	The voltage from the power supply should fall within the input voltage specification range of the drive.	166
<input type="checkbox"/>	6	The voltage rating for the motor should match the drive output specifications.	26
<b>Main circuit wiring</b>			
<input type="checkbox"/>	7	Confirm proper branch circuit protection exists per National and Local codes.	50
<input type="checkbox"/>	8	Properly wire the power supply to drive terminals R/L1, S/L2 and T/L3.	-
<input type="checkbox"/>	9	Properly wire the drive and motor together. The motor lines and drive output terminals R/T1, V/T2 and W/T3 should match in order to produce the desired phase order. If the phase order is incorrect, the drive will rotate in the opposite direction.	62
<input type="checkbox"/>	10	Use 600 Vac vinyl-sheathed wire for the power supply and motor lines.	59
<input type="checkbox"/>	11	Use the correct wire gauges for the main circuit. Refer to <a href="#">Table 3.2</a> , <a href="#">Table 3.3</a> , or <a href="#">Table 3.4</a> .	59
		<ul style="list-style-type: none"> <li>When using comparatively long motor cable, calculate the amount of voltage drop. <div style="border: 1px solid black; padding: 5px; margin: 5px 0;"> <math display="block">\text{Motor rated voltage (V)} \times 0.02 \geq 3 \times \text{voltage resistance } (\Omega/\text{km}) \times \text{cable length (m)} \times \text{motor rated current (A)} \times 10^{-3}</math> </div> </li> <li>If the cable between the drive and motor exceeds 50 m, adjust the carrier frequency (C6-02) accordingly.</li> </ul>	59
<input type="checkbox"/>	12	Properly ground the drive. Review page <a href="#">63</a> .	63
<input type="checkbox"/>	13	Tightly fasten all terminal screws (control circuit terminals, grounding terminals). Refer to <a href="#">Table 3.2</a> , <a href="#">Table 3.3</a> , or <a href="#">Table 3.4</a> .	59

## 3.8 Wiring Checklist

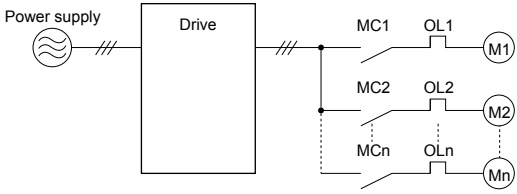
☑	No.	Item	Page
☐	14	<p>Set up overload protection circuits when running multiple motors from a single drive.</p>  <p>MC1 - MCn ... magnetic contactor OL 1 - OL n ... thermal relay</p> <p><b>Note:</b> Close MC1 through MCn before operating the drive.</p>	-
☐	15	If using a braking resistor or dynamic braking resistor unit, install a magnetic contactor. Properly install the resistor, and ensure that overload protection shuts off the power supply.	-
☐	16	Verify phase advancing capacitors are NOT installed on the output side of the drive.	-
<b>Control circuit wiring</b>			
☐	17	Use twisted-pair cables for all drive control circuit wiring.	65
☐	18	Ground the shields of shielded wiring to the GND ⊕ terminal.	70
☐	19	If using a 3-Wire sequence, properly set parameters for multi-function contact input terminals S1 through S7, and properly wire control circuits.	52
☐	20	Properly wire any option cards.	-
☐	21	Check for any other wiring mistakes. Only use a multimeter to check wiring.	-
☐	22	Properly fasten the control circuit terminal screws in the drive. Refer to <a href="#">Table 3.2</a> , <a href="#">Table 3.3</a> , or <a href="#">Table 3.4</a> .	59
☐	23	Pick up all wire clippings.	-
☐	24	Ensure that no frayed wires on the terminal block are touching other terminals or connections.	-
☐	25	Properly separate control circuit wiring and main circuit wiring.	-
☐	26	Analog signal line wiring should not exceed 50 m.	-
☐	27	Safe Disable Input wiring should not exceed 30 m.	-



# Start-Up Programming & Operation

---

This chapter explains the functions of the LED operator and how to program the drive for initial operation.

<b>4.1</b>	<b>USING THE DIGITAL LED OPERATOR.....</b>	<b>80</b>
<b>4.2</b>	<b>THE DRIVE AND PROGRAMMING MODES.....</b>	<b>84</b>
<b>4.3</b>	<b>START-UP FLOWCHARTS.....</b>	<b>87</b>
<b>4.4</b>	<b>POWERING UP THE DRIVE.....</b>	<b>92</b>
<b>4.5</b>	<b>APPLICATION SELECTION.....</b>	<b>93</b>
<b>4.6</b>	<b>BASIC DRIVE SETUP ADJUSTMENTS.....</b>	<b>102</b>
<b>4.7</b>	<b>AUTO-TUNING.....</b>	<b>109</b>
<b>4.8</b>	<b>NO-LOAD OPERATION TEST RUN.....</b>	<b>118</b>
<b>4.9</b>	<b>TEST RUN WITH LOAD CONNECTED.....</b>	<b>120</b>
<b>4.10</b>	<b>TEST RUN CHECKLIST.....</b>	<b>121</b>

### 4.1 Using the Digital LED Operator

Use the LED operator to enter run and stop commands, display data, edit parameters, as well as display fault and alarm information.

#### ◆ Keys, Displays, and LEDs

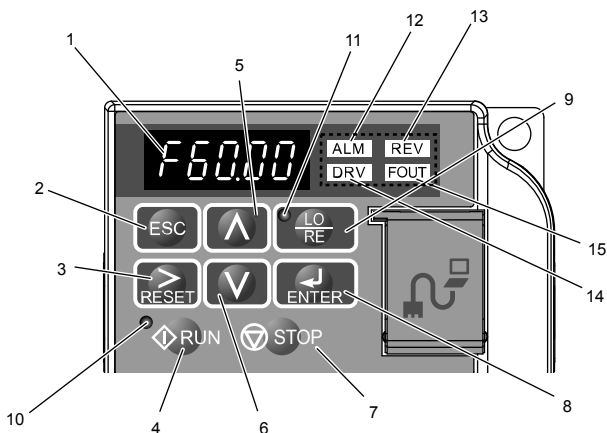







**Table 4.1 Keys and Displays on the LED Operator**

No.	Display	Name	Function
1		Data Display Area	Displays the frequency reference, parameter number, etc.
2		ESC Key	Returns to the previous menu.
3		RESET Key	Moves the cursor to the right. Resets the drive to clear a fault situation.
4		RUN Key	Starts the drive.
5		Up Arrow Key	Scrolls up to select parameter numbers, setting values, etc.
6		Down Arrow Key	Scrolls down to select parameter numbers, setting values, etc.
7		STOP Key	Stops the drive. <b>Note:</b> Stop priority circuit. A fast-stop is available by pressing the STOP key when the drive detects a danger even if the drive is running by a signal from the multi-function contact input terminal (REMOTE is set). To avoid stoppage by using the STOP key, set o2-02 (STOP Key Function Selection) to 0 (Disabled).
8		ENTER Key	Selects all modes, parameters, settings, etc. Selects a menu item to move from one display screen to the next.
9		LO/RE Selection Key	Switches drive control between the operator (LOCAL) and the control circuit terminals (REMOTE). <b>Note:</b> LOCAL/REMOTE key effective during stop in drive mode. If the digital operator could change from REMOTE to LOCAL by incorrect operation, set o2-01 (LOCAL/REMOTE Key Function Selection) to "0" (disabled) to disable LOCAL/REMOTE key.
10		RUN Light	Lit while the drive is operating the motor.
11		LO/RE Light	Lit while the operator (LOCAL) is selected to run the drive.
12		ALM LED Light	<i>Refer to LED Screen Displays on page 82.</i>
13		REV LED Light	
14		DRV LED Light	
15		FOUT LED Light	







## 4.1 Using the Digital LED Operator

### ◆ LED Screen Displays

Display	Lit	Flashing	Off
	When the drive detects an alarm or error	<ul style="list-style-type: none"> <li>When an alarm occurs</li> <li>oPE detected</li> <li>When a fault or error occurs during Auto-Tuning</li> </ul>	Normal state (no fault or alarm)
	Motor is rotating in reverse	—	Motor is rotating forward
	Drive Mode Auto-Tuning	When DriveWorksEZ is used <1>	Programming Mode
	Displays output frequency (Hz)	—	—
As illustrated in this manual			

<1> Refer to the DriveWorksEZ instruction manual for further information.

### ◆ LO/RE LED and RUN LED Indications

LED	Lit	Flashing	Flashing Quickly	Off
	When run command is selected from LED operator (LOCAL)	—	—	Run command is selected from device other than LED operator (REMOTE)
	During run	<ul style="list-style-type: none"> <li>During deceleration to stop</li> <li>When a run command is input and frequency reference is 0</li> </ul>	<ul style="list-style-type: none"> <li>During deceleration at a fast-stop.</li> <li>During deceleration</li> <li>During stop by interlock operation.</li> </ul>	During stop
As shown				

◆ Menu Structure for Digital LED Operator

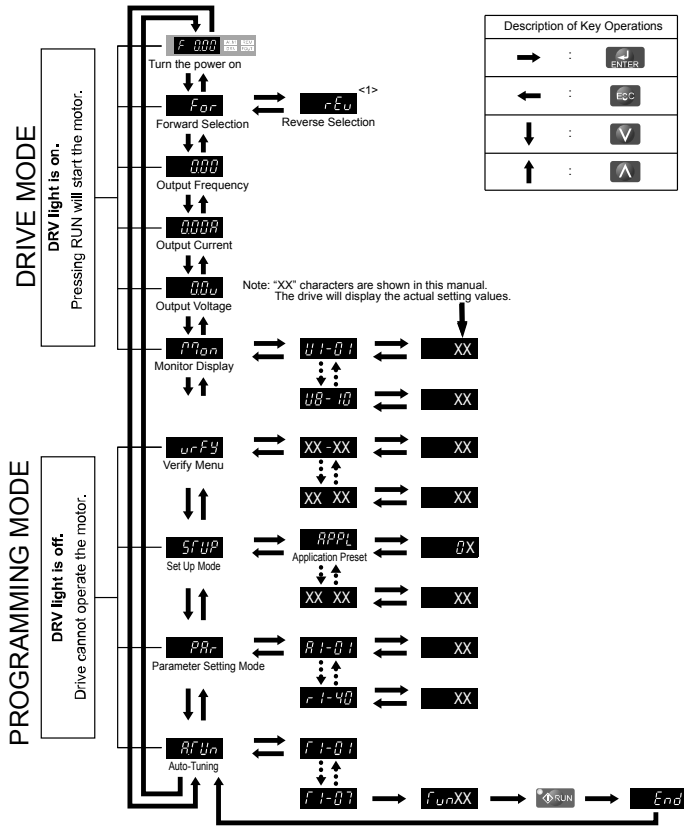

Figure 4.1 Digital LED Operator Screen Structure

<1> Reverse can only be selected when LOCAL is set.

### 4.2 The Drive and Programming Modes

The drive functions are divided into two main groups accessible via the Digital LED Operator:

**Drive Mode:** The Drive mode allows motor operation and parameter monitoring. Parameter settings cannot be changed when accessing functions in the Drive Mode.

**Programming Mode:** The Programming Mode allows access to setup/adjust, verify parameters and Auto-Tuning. The drive prohibits changes in motor operation such as start/stop when the Digital LED Operator is accessing a function in the Programming Mode.

#### ◆ Changing Parameter Settings or Values

This example explains changing C1-01 (Acceleration Time 1) from 10.0 seconds (default) to 20.0 seconds.

Step			Display/Result
1.	Turn on the power to the drive. The initial display appears.	➔	
2.	Press the  key until the Setup Mode Screen appears.	➔	
3.	Press the  key to view the parameter setting display.	➔	
4.	Scroll through parameters by pressing the  key until C1-01 appears.	➔	
5.	Press  to view the current setting value (10.0). (Number farthest to the left flashes)	➔	
6.	Press  until the desired number is selected. ("1" flashes)	➔	
7.	Press the  key and enter 0020.0.	➔	
8.	Press  and the drive will confirm the change.	➔	
9.	The display automatically returns to the screen shown in Step 4.	➔	
10.	Press the  key until back at the initial display.	➔	

### ◆ Switching Between LOCAL and REMOTE





Entering the run command using the LED operator is referred to as LOCAL, while entering the run command from an external device via the control circuit terminals or network option card is referred to as REMOTE.

**WARNING! Sudden Movement Hazard.** The drive may start unexpectedly if the Run command is already applied when switching from LOCAL mode to REMOTE mode when b1-07 = 1, resulting in death or serious injury. Be sure all personnel are clear of rotating machinery and electrical connections prior to switching between LOCAL mode and REMOTE mode.

There are two ways to switch between LOCAL and REMOTE.

- Note:**
1. After selecting LOCAL, the LO/RE light will remain lit.
  2. The drive will not allow the user to switch between LOCAL and REMOTE during run.

### ■ Using the LO/RE Key on the LED Operator

Step			Display/Result
1.	Turn on the power to the drive. The initial display appears.	➔	
2.	<p>Press . The LO/RE light will light up. The drive is now in Local.</p> <p>To set the drive for REMOTE operation, press the  key again.</p>	➔	 

### ■ Using Input Terminals S1 through S7 to Switch between LO/RE

Switch between LOCAL and REMOTE using one of the digital input terminals S1 through S7 (set the corresponding parameter H1-01 through H1-07 to “1”).

Follow the example below to set the digital input terminals.

- Note:**
1. For a list of digital input selections, [Refer to Parameter List on page 157.](#)
  2. Setting a multi-function input terminal to a value of 1 disables the LO/RE key on the LED operator.

### ◆ Parameters Available in the Setup Group

#### ■ Setup Mode (STUP)

Parameters used for this drive are classified into A to U. To simplify the drive setup, frequently used parameters are selected and input into Setup Mode.

## 4.2 The Drive and Programming Modes

1. To set a parameter, the Setup Mode must be displayed first. Press the Up/Down key until *SETUP* is displayed.
2. Select the parameter and change the setting. **Table 4.2** lists parameters available in the Setup group. If the desired parameter cannot be set in the Setup mode, use the Parameter Setting mode.

**Note:** When parameter A1-02 (Control Method Selection) is changed, some parameter set values are also changed automatically.

**Note:** Use the “Par” menu in the Programming mode to access parameters not listed in the Setup Group.

**Note:** Display parameters depend on A1-06. *Refer to Application Selection on page 93.*

**Table 4.2 Setup Group Parameters**

Parameter	Name	Parameter	Name
A1-02	Control Method Selection	E1-03	V/f Pattern Selection
b1-01	Frequency Reference Selection 1	E1-04	Maximum Output Frequency
b1-02	Run Command Selection 1	E1-05	Maximum Voltage
b1-03	Stop Method Selection	E1-06	Base Frequency
C1-01	Acceleration Time 1	E1-09	Minimum Output Frequency
C1-02	Deceleration Time 1	E1-13	Base Voltage
C6-01	Duty Selection	E2-01	Motor Rated Current
C6-02	Carrier Frequency Selection	E2-04	Number of Motor Poles
d1-01	Frequency Reference 1	E2-11	Motor Rate Capacity
d1-02	Frequency Reference 2	H4-02	Terminal AM Gain Setting
d1-03	Frequency Reference 3	L1-01	Motor Protection Function Selection
d1-04	Frequency Reference 4	L3-04	Stall Prevention Selection during Deceleration
d1-17	Jog Frequency Reference		
E1-01	Input Voltage Reference		

## 4.3 Start-up Flowcharts

The flowcharts in this section summarize basic steps required to start the drive. Use the flowcharts to determine the most appropriate start-up method for a given application. The charts are intended as a quick reference to help familiarize the user with start-up procedures.

Flowchart	Subchart	Objective	Page
A		Basic startup procedure and motor tuning.	<a href="#">88</a>
	A-1	Simple motor setup with Energy Savings or Speed Search using V/f mode.	<a href="#">89</a>
	A-2	High-performance operation using Open Loop Vector (OLV) motor control.	<a href="#">90</a>
	A-3	Operation with Permanent Magnet (PM) motors.	<a href="#">91</a>
	-	Setup of drive using application specific selections. <a href="#">Refer to Application Selection on page 93.</a>	-

## ◆ Flowchart A: Basic Start-up and Motor Tuning

**Figure 4.2**, Flowchart A, describes basic start-up sequence for the drive and motor system. This sequence varies slightly depending on application. Use drive default parameter settings in simple applications that do not require high precision.

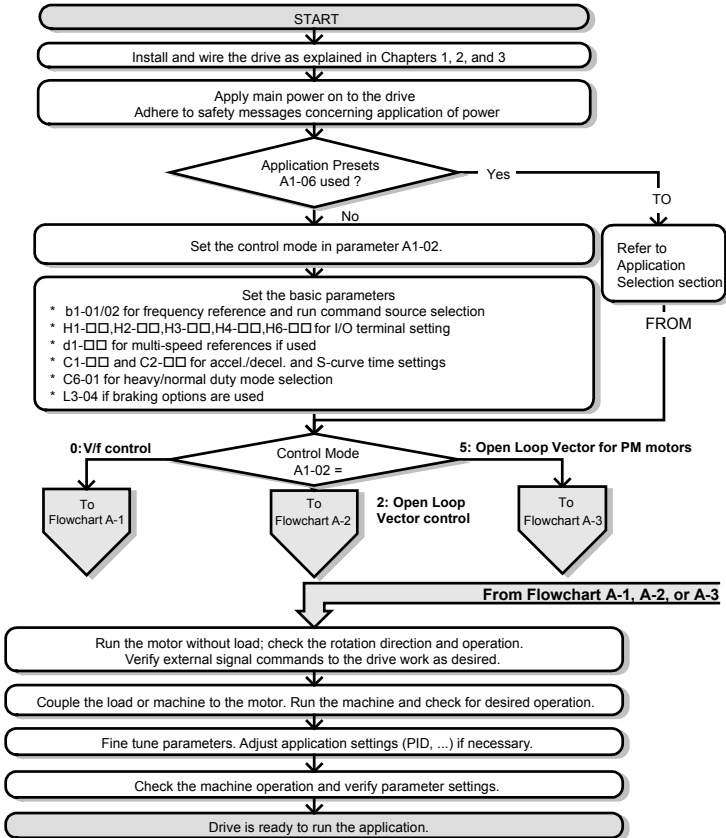

**Figure 4.2 Basic Start-Up and Motor Tuning**

## ◆ Subchart A1: Simple Motor Setup with Energy Savings or Speed Search Using V/f Mode

**Figure 4.3**, Flowchart A1, describes simple motor setup for V/f control. V/f Motor Control is suited for the most basic applications such as fans or pumps. This procedure illustrates using Energy Savings and Speed Estimation Speed Search. V/f control can be used where rotational auto-tuning cannot be performed.

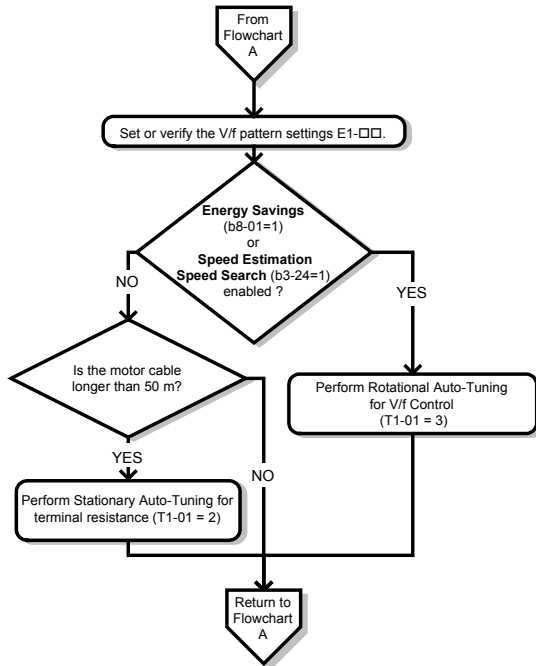

**Figure 4.3** Simple Motor Setup with Energy Savings or Speed Search Using V/f Mode

#### ◆ Subchart A2: High Performance Operation Using Open Loop Vector Motor Control

*Figure 4.4*, Flowchart A2, describes Open Loop Vector Control for high-performance motor operation. This is appropriate for applications requiring high starting torque, torque limits, and improved speed regulation.

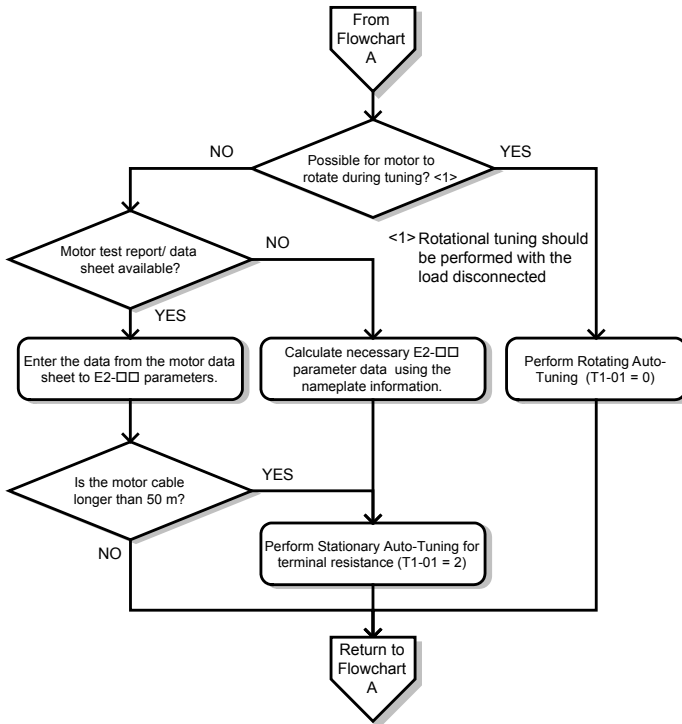

**Figure 4.4 Flowchart A2: High Performance Operation Using Open Loop Vector Motor Control**

### ◆ Subchart A3: Operation with Permanent Magnet Motors

*Figure 4.5*, Flowchart A3, describes tuning for PM motors in Open Loop Vector Control. PM motors can be used for energy savings in reduced or variable torque applications.

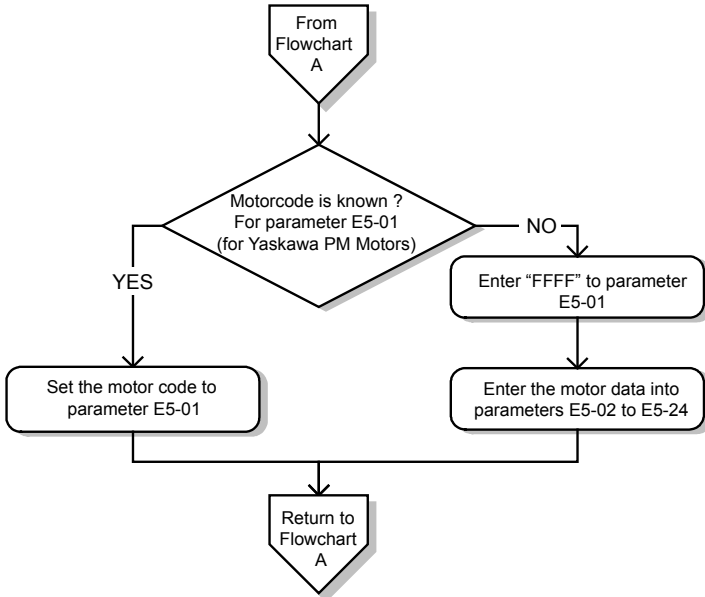

Figure 4.5 Operation with Permanent Magnet Motors

# 4.4 Powering Up the Drive

## ◆ Powering Up the Drive and Operation Status Display



### ■ Powering Up the Drive

Review the following checklist before turning the power on.

Item to Check	Description
Power supply voltage	Ensure the power supply voltage is correct: 200 V class: single-phase 200 to 240 Vac 50/60 Hz 200 V class: 3-phase 200 to 240 Vac 50/60 Hz 400 V class: 3-phase 380 to 480 Vac 50/60 Hz
	Properly wire the power supply input terminals (R/L1, S/L2, T/L3). (for single-phase 200 V class models, wire only R/L1 and S/L2)
	Check for proper grounding of drive and motor.
Drive output terminals and motor terminals	Properly wire drive output terminals U/T1, V/T2, and W/T3 with motor terminals U, V, and W.
Control circuit terminals	Check control circuit terminal connections.
Drive control terminal status	Open all control circuit terminals (off).
Status of the load and connected machinery	Uncouple the motor from the load.

### ■ Status Display

When the power supply to the drive is turned on, the LED operator lights will appear as follows:

No.	Name	Description
Normal Operation		The data display area displays the frequency reference. [DRV] is lit.
Fault	 Main circuit low voltage (ex)	Data displayed varies by the type of fault. <i>Refer to Fault Displays, Causes, and Possible Solutions on page 125</i> for more information and possible solution. [ALM] and [DRV] are lit.

**Note:** Display will vary depending on drive settings.

## 4.5 Application Selection

Several Application Presets are available to facilitate drive setup for commonly used applications. Selecting one of these Application Presets automatically sets the required parameters to the Application Preset default values and selects I/Os. In addition, the parameters most likely to be changed are assigned to the list of User Parameters, A2-01 through A2-16. These can be accessed in the Setup Mode and provide quicker application adjustment by eliminating the need to scroll through multiple menus.

The following presets can be selected:

- Note:**
1. The drive parameters should be initialized by setting A1-03 to “2220” or “3330” prior to selecting an Application Preset.
  2. Once an Application Preset has been selected, a different Application Preset cannot be selected again until A1-03 is assigned to 2220 or 3330 (2-wire initialization or 3-wire initialization).

**WARNING!** Confirm the drive I/O signals and external sequence before performing a test run. Setting parameter A1-06 may change the I/O terminal function automatically from the default setting. Failure to comply may result in death or serious injury.

No.	Parameter Name	Setting Range	Default
A1-06	Application Preset	0: Disabled 1: Water supply pump 2: Conveyor 3: Exhaust fan 4: HVAC 5: Compressor </>	0

<1> Application Preset settings 6 and 7 are only available in software versions 5010, 1010, and 1011. To determine the drive software version, refer to the PRG: field on the drive nameplate or drive parameter U1-25.

### ◆ Setting 1: Water Supply Pump Application

Table 4.3 Water Supply Pump Parameter Settings

No.	Name	Default Setting
A1-02	Control Method Selection	0: V/f Control
b1-04	Reverse Operation Selection	1: Reverse Prohibited
C1-01	Acceleration Time 1	1.0 s
C1-02	Deceleration Time 1	1.0 s
C6-01	Duty Rating	1: Normal Duty
E1-03	V/f Pattern Selection	0FH
E1-07	Mid Output Frequency	30.0 Hz

## 4.5 Application Selection

No.	Name	Default Setting
E1-08	Mid Output Frequency Voltage	50.0 V
L2-01	Momentary Power Loss Operation Selection	1: Enabled
L3-04	Stall Prevention Selection during Deceleration	1: Enabled

**Table 4.4 Water Supply Pump: User Parameters (A2-01 to A2-16)**

No.	Parameter Name	No.	Parameter Name
b1-01	Frequency Reference Selection	E1-08	Mid Output Frequency Voltage
b1-02	Run Command Selection	E2-01	Motor Rated Current
b1-04	Reverse Operation Selection	H1-05	Multi-Function Digital Input Terminal S5 Function Selection
C1-01	Acceleration Time 1	H1-06	Multi-Function Digital Input Terminal S6 Function Selection
C1-02	Deceleration Time 1	H1-07	Multi-Function Digital Input Terminal S7 Function Selection
E1-03	V/f Pattern Selection	L5-01	Number of Auto Restart Attempts
E1-07	Mid Output Frequency	–	–

## ◆ Setting 2: Conveyor Application

**Table 4.5 Conveyor: Parameter Settings**

No.	Parameter Name	Default Setting
A1-02	Control Method Selection	0: V/f Control
C1-01	Acceleration Time 1	3.0 s
C1-02	Deceleration Time 1	3.0 s
C6-01	Duty Rating	0: Heavy Duty
L3-04	Stall Prevention Selection during Deceleration	1: Enabled

**Table 4.6 Conveyor: User Parameters (A2-01 to A2-16)**

No.	Parameter Name	No.	Parameter Name
A1-02	Control Method Selection	C1-02	Deceleration Time 1
b1-01	Frequency Reference Selection	E2-01	Motor Rated Current
b1-02	Run Command Selection	L3-04	Stall Prevention Selection during Deceleration

No.	Parameter Name	No.	Parameter Name
C1-01	Acceleration Time 1	–	–

### ◆ Setting 3: Exhaust Fan Application

Table 4.7 Exhaust Fan: Parameter Settings

No.	Parameter Name	Default Setting
A1-02	Control Method Selection	0: V/f Control
b1-04	Reverse Operation Selection	1: Reverse Prohibited
C6-01	Duty Selection	1: Normal Duty
E1-03	V/f Pattern Selection	0FH
E1-07	Mid Output Frequency	30.0 Hz
E1-08	Mid Output Frequency Voltage	50.0 V
L2-01	Momentary Power Loss Operation Selection	1: Enabled
L3-04	Stall Prevention Selection during Deceleration	1: Enabled

Table 4.8 Exhaust Fan: User Parameters (A2-01 to A2-16)

No.	Parameter Name	No.	Parameter Name
b1-01	Frequency Reference Selection	E1-07	Mid Output Frequency
b1-02	Run Command Selection	E1-08	Mid Output Frequency Voltage
b1-04	Reverse Operation Selection	E2-01	Motor Rated Current
b3-01	Speed Search Selection at Start	H1-05	Multi-Function Digital Input Terminal S5 Function Selection
C1-01	Acceleration Time 1	H1-06	Multi-Function Digital Input Terminal S6 Function Selection
C1-02	Deceleration Time 1	H1-07	Multi-Function Digital Input Terminal S7 Function Selection
E1-03	V/f Pattern Selection	L5-01	Number of Auto Restart Attempts

## 4.5 Application Selection

### ◆ Setting 4: HVAC Fan Application

Table 4.9 HVAC Fan: Parameter Settings

No.	Parameter Name	Default Setting
A1-02	Control Method Selection	0: V/f Control
b1-04	Reverse Operation Selection	1: Reverse Prohibited
C6-01	Duty Rating	1: Normal Duty
C6-02	Carrier Frequency Selection	3: 8.0 kHz
H2-03	Terminals P2 Function Selection	39: Watt Hour Pulse Output
L2-01	Momentary Power Loss Operation Selection	2: CPU Power Active - Drive will restart if power returns prior to control power supply shut down.
L8-03	Overheat Pre-Alarm Operation Selection	4: Operation at lower speed
L8-38	Carrier Frequency Reduction	2: Enabled across entire frequency range.

Table 4.10 HVAC Fan: User Parameters (A2-01 to A2-16)

No.	Parameter Name	No.	Parameter Name
b1-01	Frequency Reference Selection	E1-03	V/f Pattern Selection
b1-02	Run Command Selection	E1-04	Max Output Frequency
b1-04	Reverse Operation Selection	E2-01	Motor Rated Current
C1-01	Acceleration Time 1	H3-11	Terminal A2 Gain Setting
C1-02	Deceleration Time 1	H3-12	Terminal A2 Input Bias
C6-02	Carrier Frequency Selection	L2-01	Momentary Power Loss Operation Selection
d2-01	Frequency Reference Upper Limit	L8-03	Overheat Pre-Alarm Operation Selection
d2-02	Frequency Reference Lower Limit	o4-12	kWh Monitor Initial Value Selection

### ◆ Setting 5: Compressor Application

Table 4.11 Compressor: Parameter Settings

No.	Parameter Name	Default Setting
A1-02	Control Method Selection	0: V/f Control
b1-04	Reverse Operation Selection	1: Reverse Prohibited
C1-01	Acceleration Time 1	5.0 s
C1-02	Deceleration Time 1	5.0 s

No.	Parameter Name	Default Setting
C6-01	Duty Rating	0: Heavy Duty
E1-03	V/f Pattern Selection	0FH
L2-01	Momentary Power Loss Operation Selection	1: Enabled
L3-04	Stall Prevention Selection during Deceleration	1: Enabled

**Table 4.12 Compressor: User Parameters (A2-01 to A2-16):**

No.	Parameter Name	No.	Parameter Name
b1-01	Frequency Reference Selection	E1-03	V/f Pattern Selection
b1-02	Run Command Selection	E1-07	Mid Output Frequency
b1-04	Reverse Operation Selection	E1-08	Mid Output Frequency Voltage
C1-01	Acceleration Time 1	E2-01	Motor Rated Current
C1-02	Deceleration Time 1	–	–

### ◆ Setting 6: Preset 6

- Note:**
1. Read the instructions listed in on 98 when using Application Preset 6
  2. Perform Auto-Tuning after selecting Application Preset 6.
  3. If UL3 appears on the operator display after Auto-Tuning is complete, set L6-01 to “0” to repeat the Auto-Tuning process.

**Table 4.13 Preset 6: Parameters and Settings**

No.	Parameter Name	Default Setting
A1-02	Control Method Selection	2: Open Loop Vector Control
b1-01	Frequency Reference Selection	0: Operator
b6-01	Dwell Reference at Start	3.0 Hz
b6-02	Dwell Time at Start	0.3 s
C1-01	Acceleration Time 1	3.0 s
C1-02	Deceleration Time 1	3.0 s
C6-01	Duty Rating	0: Heavy Duty
C6-02	Carrier Frequency Selection	2: 5 kHz
d1-01	Frequency Reference 1	6.0 Hz
d1-02	Frequency Reference 2	30.0 Hz
d1-03	Frequency Reference 3	60.0 Hz

## 4.5 Application Selection

No.	Parameter Name	Default Setting
E1-03	V/f Pattern Selection	0FH
H2-02	Terminals P1 Function Selection	37: During Frequency Output
H2-03	Terminals P2 Function Selection	5: Frequency Detection 2
L2-03	Momentary Power Loss Minimum Baseblock Time	0.3 s
L3-04	Momentary Power Loss Voltage Recovery Ramp Time	0: Disabled
L4-01	Speed Agreement Detection Level	2.0 Hz
L4-02	Speed Agreement Detection Width	0.0 Hz
L6-01	Torque Detection Selection 1	8: UL3 at RUN - Fault
L6-02	Torque Detection Level 1	5%
L6-03	Torque Detection Time 1	0.5 s
L8-05	Input Phase Loss Protection Selection	1: Enabled </>
L8-07	Output Phase Loss Protection	1: Enabled
L8-38	Carrier Frequency Reduction	1: Enabled below 6 Hz
L8-41	Current Alarm Selection	1: Enabled (alarm is output)

<I> Disable L8-05 for single-phase models.

**Table 4.14 Preset 6: User Parameters (A2-01 to A2-16):**

No.	Parameter Name	No.	Parameter Name
A1-02	Control Method Selection	d1-02	Frequency Reference 2
b1-01	Frequency Reference Selection	d1-03	Frequency Reference 3
b6-01	Dwell Reference at Start	E1-08	Mid Output Frequency Voltage
b6-02	Dwell Time at Start	H2-01	Terminals MA, MB, and MC Function Selection
C1-01	Acceleration Time 1	L1-01	Motor Overload Protection Selection
C1-02	Deceleration Time 1	L4-01	Speed Agreement Detection Level
C6-02	Carrier Frequency Selection	L6-02	Torque Detection Level 1
d1-01	Frequency Reference 1	L6-03	Torque Detection Time 1

### ◆ Notes on Controlling the Brake when Using Application Preset 6

The frequency detection function is used for controlling the brake.

When an external Baseblock command is present while a Run command is active, the frequency reference will be kept as long as the Run command is active. To avoid improper brake operation make sure that frequency detection is set so that the brake does not open during Baseblock (L4-07 = "0", default).

The table below shows how to set up the drive when using output terminals P2-PC as brake control output.

Brake Open/Close		Brake Activation Level		Control Mode		
Function	Parameter	Signal	Parameter	V/f	OLV	OLV for PM
Frequency Detection 2	L4-07 = 0	Frequency Detection Level	L4-01 = 1.0 to 3.0 Hz <>	O	O	-
	H2-03 = 5	Frequency Detection Width	L4-02 = 0.0 to 0.5 Hz <>			

- <1> This is the setting recommended when using Open Loop Vector Control. In V/f Control, set the level as the motor rated slip frequency plus 0.5 Hz. Not enough motor torque will be created if this value is set too low, and the load may tend to slip. Make sure this value is greater than the minimum output frequency and greater than the value of L4-02 as shown in the diagram below. If set too high, however, there may be a jolt at start.
- <2> Hysteresis for Frequency Detection 2 can be adjusted by changing the Frequency Detection Width (L4-02) between 0.0 and 0.5 Hz. If the load slips during stop, make changes in steps of 0.1 Hz until the load no longer slips.

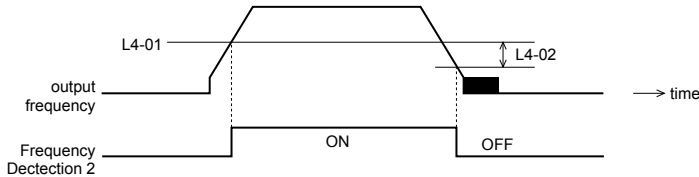

**Figure 4.6 Frequency Detection 2**

**The braking sequence should be designed as follows:**

- A normally open signal (N.O.) should be used to control the brake so that it is released when terminal P2-PC closes.
- When an Up or Down command is entered, the brake should release.
- When a fault signal is output, the brake should close.
- When changing the speed using an analog signal, make sure that the source of the frequency reference is assigned to the control circuit terminals (b1-01 = 1).
- A sequence to open and close the holding brake appears in the diagram below.

## 4.5 Application Selection

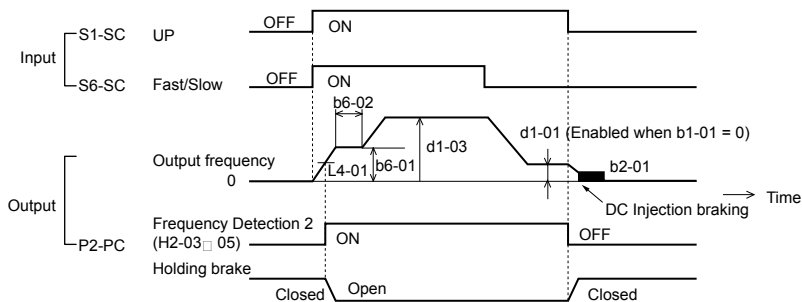

Figure 4.7 Holding Brake Time Chart

### ◆ Setting 7: Preset 7

Table 4.15 Preset 7: Parameters and Settings

No.	Parameter Name	Default Setting
A1-02	Control Mode	0: V/f Control
b1-01	Frequency Reference Selection	0: Operator
C1-01	Acceleration Time 1	3.0 s
C1-02	Deceleration Time 1	3.0 s
C6-01	Duty Cycle	0: Heavy Duty
C6-02	Carrier Frequency Selection	2: 5 kHz
d1-01	Frequency Reference 1	6.0 Hz
d1-02	Frequency Reference 2	30.0 Hz
d1-03	Frequency Reference 3	60.0 Hz
H1-05	Multi-Function Digital Input Terminal S5 Function	3: Multi-Step Speed 1
H1-06	Multi-Function Digital Input Terminal S6 Function	4: Multi-Step Speed 2
H2-02	Terminals P1 Function Selection	37: During frequency output
L3-04	Stall Prevention Selection during Decel	0: Disabled
L8-05	Input Phase Loss Protection Selection	1: Enabled </>

No.	Parameter Name	Default Setting
L8-07	Output Phase Loss Protection	1: Triggered when a single phase is lost
L8-38	Carrier Frequency Reduction	1: Enabled below 6 Hz
L8-41	Current Alarm Selection	1: Enabled (alarm output)

<1> Disable L8-05 for single-phase models.

**Table 4.16 Preset 7: User Parameters (A2-01 to A2-16):**

No.	Parameter Name	No.	Parameter Name
b1-01	Frequency Reference Selection	d1-03	Frequency Reference 3
C1-01	Acceleration Time 1	E2-01	Motor Rated Current
C1-02	Deceleration Time 1	H1-05	Multi-Function Digital Input Terminal S5 Function
C6-02	Carrier Frequency Selection	H1-06	Multi-Function Digital Input Terminal S6 Function
d1-01	Frequency Reference 1	H2-01	Terminals MA, MB, and MC Function Selection
d1-02	Frequency Reference 2	L1-01	Motor Overload Protection Selection

# 4.6 Basic Drive Setup Adjustments

This section explains the basic settings required for initial drive operation. Checking these basic parameter settings during start-up will help to ensure a successful drive start-up.

If more information is required for parameters not listed in this section, *Refer to Parameter List on page 157* as required for a complete listing of drive parameters.

## ◆ Control Mode Selection: A1-02

### ■ Available Control Modes

Three motor control modes are available. Select the control mode that best suits the application in which the drive will be used.

Control Mode	Parameter	Main Applications
V/f Control	A1-02 = 0 (default)	<ul style="list-style-type: none"><li>• General variable speed applications</li><li>• For running multiple motors from a single drive</li><li>• When replacing a drive in which parameter settings are unknown.</li></ul>
Open Loop Vector Control	A1-02 = 2	<ul style="list-style-type: none"><li>• General variable speed applications</li><li>• Applications requiring high precision, high speed control.</li></ul>
PM Open Loop Vector Control	A1-02 = 5	Variable torque applications employing permanent magnet motors and energy savings.

## ◆ Initialize Parameter Values: A1-03

Parameter A1-03 (Initialize Parameters) resets all parameters to the original default values.

- Note:**
1. Save all changed parameter settings by setting o2-03 = "1" before initializing the drive. Settings will be lost if performing a 2-Wire or 3-Wire initialization using 2220 or 3330 if user parameters are not saved first.
  2. If using Open Loop Vector Control (A1-02 = 2), Auto-Tuning will need to be performed again after the drive is initialized. *Refer to Auto-Tuning on page 109* for details.

### ■ Different Methods of Drive initialization

#### 1110: Resets all parameters to user-defined default values

A user-initialization resets all parameters to a user-defined set of default values previously saved to the drive. Set parameter o2-03 to "2" to clear those values.

- Note:** Set o2-03 to "1" to save the current parameter settings and changes for a "user-initialization." After saving all parameter setting changes, parameter o2-03 automatically returns to 0. .

### 2220: 2-Wire Initialization

Returns all parameters to factory default values for 2-Wire control. A 2-Wire sequence assigns functions to input terminals S1 and S2.

### 3330: 3-Wire Initialization

Returns all parameters to factory default values for 3-Wire control. A 3-Wire sequence assigns functions to input terminals S1, S2, and S5.

### 5550: Uploads Parameter Data from the Removable Control Circuit Terminal Board

Replacing either the removable control circuit terminal board or the drive and applying main power may result in an oPE04 fault. If parameter setting data in the removable control circuit terminal board is correct, set A1-03 to “5550” to upload the data to the drive.

**Note:** *Refer to Run Command Input Selection: b1-02 on page 105* for more information on a 2-Wire and 3-Wire sequence.

**Note:** Initializing the drive for 2-Wire sequence (A1-03 = 2220) returns all drive parameters to factory settings. Back up all parameters in the event of accidental initialization. the data with 2-Wire sequence returns all the set parameters to the factory settings.

---

## ◆ Frequency Reference Source: b1-01

This section explains how to assign the frequency reference. Parameters b1-01 and b1-02 can be used to select the source of the run command and the frequency reference independently (e.g., set the reference from the operator and set the run command from the terminals).

### ■ Frequency Reference from the LED Operator: b1-01 = 0

When b1-01 = 0 the frequency reference will be provided by the LED operator. *Refer to The Drive and Programming Modes on page 84* for information on how to set the frequency reference.

### ■ Frequency Reference from the Analog Input Terminal: b1-01 = 1

When b1-01 = 1, analog inputs A1 and A2 provide the frequency reference.

**Note:** Set H3-02 (Terminal A1 Function Selection) to “0” to configure Terminal A1 for the main analog frequency reference.

### Using a Single Analog Signal (V or I) as the Frequency Reference Control Circuit Terminal A1 (Voltage Input):

When entering the main frequency reference with a voltage signal, use the voltage input set up in control circuit terminal A1.

## 4.6 Basic Drive Setup Adjustments

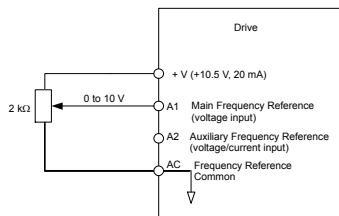

Figure 4.8 Voltage Input for the Main Frequency Reference

### Control Circuit Terminal A2 (Voltage/Current Input):

Use control circuit Terminal A2 when supplying the frequency reference with a current signal between 4 to 20 mA. Use the following switch and parameter settings to configure Terminal A2 for 0 to 20 mA or 4 to 20 mA input.

### Switching between Main/Auxiliary Frequency References

To configure the frequency reference to switch between analog input A1 and A2 (main/aux frequency switch), use the following setup:

1. Set the frequency reference source to terminals (b1-01 = "1").
2. Set one of the digital inputs to auxiliary reference 1, H1-□□ = "3" (preset for terminal S5).
3. Set input signal type of terminal A2 using dip switch S1 and parameter H3-09.
4. Set the function of analog input A2 to Auxiliary frequency (H3-10 = "3").

When the digital input assigned in step 2 is off, terminal A1 is the frequency reference input. If it is closed, the A2 input value becomes the frequency reference. The active acceleration/deceleration times are used for the change-over between the values

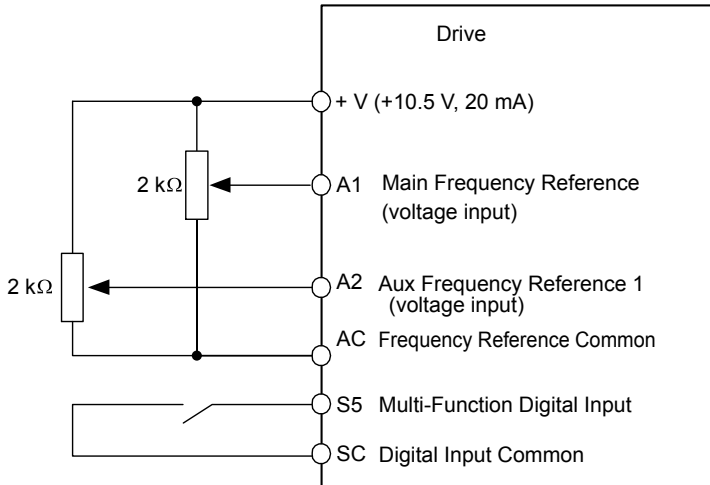

Figure 4.9 Switching between Main/Auxiliary Frequency References

### ◆ Run Command Input Selection: b1-02

This section explains how to assign the run command input.

Parameters b1-01 and b1-02 can be used to select the source of the run command and the frequency reference independently, e.g. set the reference from the operator and set the run command from the terminals.

**WARNING!** *Sudden Movement Hazard. When the run command is given by turning on the power to the drive, the motor will begin rotating as soon as the drive is powered up. Be sure to take proper precautions if using this setting. Ensure the area around the motor is safe. Failure to comply could result in death or serious injury.*

### ■ Run the Drive at 6 Hz using the Digital LED Operator: b1-02 = 0

To assign the run command to the operator panel, set parameter b1-01 to “0”. This will set up the drive to acknowledge the run command through the LED operator. Initialize the run command using the Run and Stop keys. Upon power up, the drive uses parameter b1-02 to determine the run command location.

The following procedure indicates how to start and stop the drive through the LED operator after parameter b1-02 has been set to 0.

**Note:**

When b1-02 (Run Command Selection) is not set to 0 (operator), press  to set LOCAL.

## 4.6 Basic Drive Setup Adjustments

Step			Display/Result
1.	Turn on the power to the drive. The initial display appears.	→	
2.	Set the frequency reference to F6.00 (6 Hz).	→	
3.	Press the  key to start the motor.	→	
4.	The motor should accelerate up to 6 Hz while the RUN light is on.	→	
5.	Press the  key to stop the motor. The RUN light will flash until the motor comes to a complete stop.	→	

### ■ Run the Drive using Digital Input Terminals: b1-02 = 1

This setting uses the digital input terminals to enter the run command. The factory setting is a 2-Wire sequence.

#### Using a 2-Wire Sequence

Digital Input Terminals	ON	OFF
S1	Forward Run	Stop
S2	Reverse Run	Stop

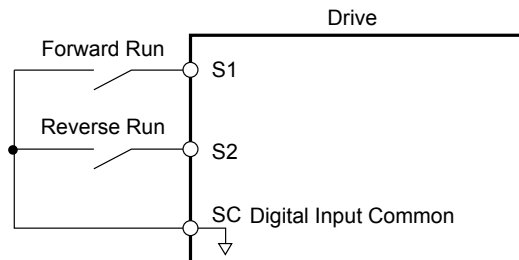
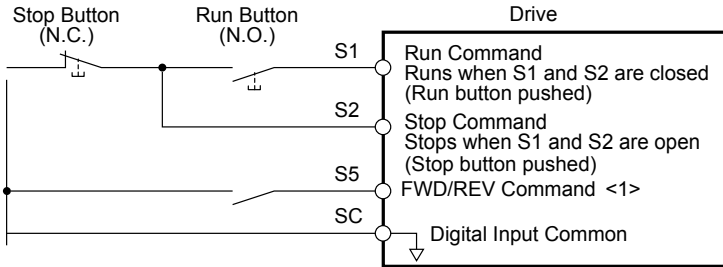

Figure 4.10 Example Wiring Diagram for 2-Wire Sequence

### Using a 3-Wire Sequence

When H1-05 (Multi-Function Digital Input Terminal S5 Function Selection) = 0, the functions of terminals S1 and S2 are set to 3-Wire sequence, and the multi-function input terminal becomes forward/reverse run command terminal.



**Figure 4.11 Example Wiring Diagram for 3-Wire Sequence Using Terminal S5**

<1> When terminal S5 is open, the motor rotates forward. When closed, the motor rotates in reverse.

**WARNING!** When 3-Wire sequence is used, set the drive to 3-Wire sequence before wiring the control terminals and ensure parameter b1-17 is set to 0 (drive does not accept a run command at power up (default)). If the drive is wired for 3-Wire sequence but set up for 2-Wire sequence (default) and if parameter b1-17 is set to 1 (drive accepts a Run command at power up), the motor will rotate in reverse direction at power up of the drive and may cause injury.

**CAUTION!** The motor will begin rotating as soon as the power is switched on. Proper precautions must be taken to ensure that the area around the motor is safe prior to powering up the drive. Failure to do so may result in minor or moderate injury.

**Note:** Run by Turning on/off the Power Supply. For safety reasons, the drive is initially set up not to accept a run command at power up (b1-17 = "0"). If a run command is issued at power up, the RUN indicator LED will flash quickly. To change this and have the run command issued by the drive, change parameter b1-17 to 1.

## ◆ Drive Duty Mode and Carrier Frequency Selection: C6-01 and C6-02

### ■ Drive Duty Mode Selection: C6-01

The drive has two different duty modes from which to select based on the load characteristics. The drive rated current, overload capacity, carrier frequency, and maximum output frequency will change depending upon the duty mode selection. Use parameter C6-01 (Duty Cycle) to select Heavy Duty (HD) or Normal Duty (ND) for the application. The factory setting is ND. [Refer to Specifications on page 149](#) for details about the rated current.

## 4.6 Basic Drive Setup Adjustments

### ■ Carrier Frequency Selection: C6-02

#### Fixed Carrier Frequencies

The carrier frequency can be set using parameter C6-02 as shown in table below.

Parameter	Name	Description	Setting Range	Default
C6-02	Carrier frequency	1 : 2.0 kHz 2 : 5.0 kHz 3 : 8.0 kHz 4 : 10.0 kHz 5 : 12.5 kHz 6 : 15.0 kHz 7: Swing PWM1 8: Swing PWM2 9: Swing PWM3 A: Swing PWM4 F : User defined (C6-03 to C6-05)	1 to F	depends on drive size

**Note:** Settings 7 through A for parameter C6-02 use a Swing PWM equivalent to a 2 kHz audible noise. This function turns the motor noise into a less obtrusive white noise.

**Note:** The upper limit for the carrier frequency is determined by drive capacity.

### ◆ Drive Input Voltage Setting: E1-01

Set E1-01 according to the power supply voltage. This setting serves as a base value for certain drive protective functions.

**NOTICE:** Set drive input voltage (not motor voltage) in parameter E1-01 for proper function of the protective features of the drive. Failure to comply could result in improper drive operation. Set parameter E1-01 to match the input voltage of the drive.

Parameter	Name	Description	Setting Range	Default
E1-01	Input Voltage Setting	Set to the nominal voltage of the incoming line. Sets the maximum and base voltage used by preset V/f patterns (E1-03), and adjusts the levels of drive protective features (e.g., overvoltage, braking resistor level, stall prevention, etc.).	200 V Class: 155 to 255 400 V Class: 310 to 510	230 V <I>

<I> The default value shown here is for 200 V class drives. Double the value for 400 V class drives.

## 4.7 Auto-Tuning

### ◆ Types of Auto-Tuning

There are three types of Auto-Tuning. Select the best type of Auto-Tuning for the application. Refer to *Auto-Tuning Procedure on page 111*.

Type	Setting	Application Conditions and Benefits	Control Mode
Rotational Auto-Tuning for V/f Control	T1-01 = 3	<ul style="list-style-type: none"> <li>Assumes the motor can rotate during the Auto-Tuning process</li> <li>Improves torque compensation, slip compensation, energy savings, and Speed Search performance</li> <li>Should be performed when Speed Estimation Type Speed Search or Energy Saving is used in V/f Control</li> </ul>	V/f Control
Rotational Auto-Tuning for OLV Control	T1-01 = 0	<ul style="list-style-type: none"> <li>Assumes the motor can rotate during the Auto-Tuning process</li> <li>Achieves high-performance motor control and should be performed whenever Open Loop Vector Control is used</li> </ul>	Open Loop Vector Control
Stationary Auto-Tuning for Line-to-Line Resistance (V/f and OLV Control)	T1-01 = 2	For use when: <ul style="list-style-type: none"> <li>The motor cable exceeds 50 m</li> <li>The motor cable length has been modified after Auto-Tuning has been previously performed</li> <li>When motor capacity and drive capacity differ</li> </ul>	V/f Control, Open Loop Vector Control

**Note:** Auto-Tuning cannot be performed on permanent magnet motors (IPM, SPM, etc.).

### ◆ Before Auto-Tuning the Drive

Check the items below before Auto-Tuning the drive.

#### ■ Basic Auto-Tuning Preparations

- Auto-Tuning automatically determines the electrical characteristics of the motor. This is fundamentally different from other types of Auto-Tuning features used in servo systems.
- Auto-Tuning requires the user to input data from the motor nameplate. Make sure the information written on the nameplate is available before Auto-Tuning the drive.
- For best performance, be sure the drive input supply voltage equals or exceeds the motor rated voltage.

**Note:** Performance can be enhanced by using a motor with a base voltage that is 20 V (40 V for 400 V class models) lower than the input supply voltage. This may be of special importance when operating the motor above 90% of base speed, where high torque precision is required.

## 4.7 Auto-Tuning

---

- Auto-Tuning is not possible with permanent magnet motors.
- To cancel Auto-Tuning, press the STOP key on the LED operator.
- **Table 4.17** describes digital input and output terminal status during Auto-Tuning.

**Table 4.17 Digital Input and Output Operation During Auto-Tuning**

Auto-Tuning Type	Digital Input	Digital Output
Rotational Auto-Tuning for V/f Control	Not available	Functions the same as during normal operation
Rotational Auto-Tuning for OLV Control	Not available	Functions the same as during normal operation
Stationary Auto-Tuning for Line-to-Line Resistance	Not available	Maintains the status at the start of Auto-Tuning

**WARNING! Sudden Movement Hazard.** Do not release the mechanical brake during stationary Auto-Tuning. Inadvertent brake release may cause damage to equipment or injury to personnel. Ensure that the mechanical brake release circuit is not controlled by the drive multi-function digital outputs.

**Note:** It is recommended that Rotational Auto-Tuning is performed with the load disconnected. Failure to comply could result in improper drive operation. If Rotational Auto-Tuning is performed for a motor coupled to a load, the motor constants will be inaccurate and the motor may exhibit abnormal operation. Disconnect or decouple the motor from the load.

### ■ Notes on Rotational Auto-Tuning

- For optimal performance, Auto-Tuning should only be done with the motor uncoupled from the load for applications requiring high performance over a wide speed range.
- If motor and load can not be uncoupled, the load should be lower than 30% of the rated load. Performing Rotational Auto-Tuning with a higher load will set motor parameters incorrectly, and can cause irregular motor rotation.
- Ensure the motor-mounted brake is fully released if installed.
- Connected machinery should be allowed to rotate the motor.

### ■ Notes on Stationary Auto-Tuning for Terminal Resistance Only

- If the motor cable lead length has been significantly modified after Auto-Tuning has already been performed, perform Stationary Auto-Tuning with the new cables.
- Perform when using motor cables longer than 50 m with V/f Control.

**WARNING! Electrical Shock Hazard.** When executing stationary Auto-Tuning for line-to-line resistance only, the motor does not rotate, however, power is applied. Do not touch the motor until Auto-Tuning is completed. Failure to comply may result in injury from electrical shock.

---

## ◆ Auto-Tuning Interruption and Fault Codes

If tuning results are abnormal or the STOP key is pressed before completion, Auto-Tuning will be interrupted and a fault code will be displayed on the digital operator.

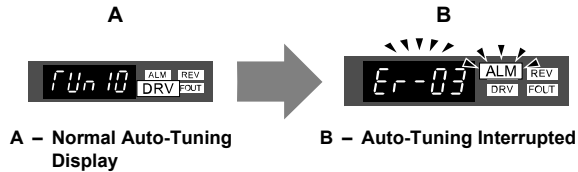

Figure 4.12 Auto-Tuning Interruption Display

## ◆ Performing Auto-Tuning

### ■ Auto-Tuning Procedure

Auto-Tuning should generally be performed in the following steps.

1. [Refer to Before Auto-Tuning the Drive on page 109.](#)
2. Determine which type of Auto-Tuning best fits the application requirements following [Figure 4.13.](#)

## 4.7 Auto-Tuning

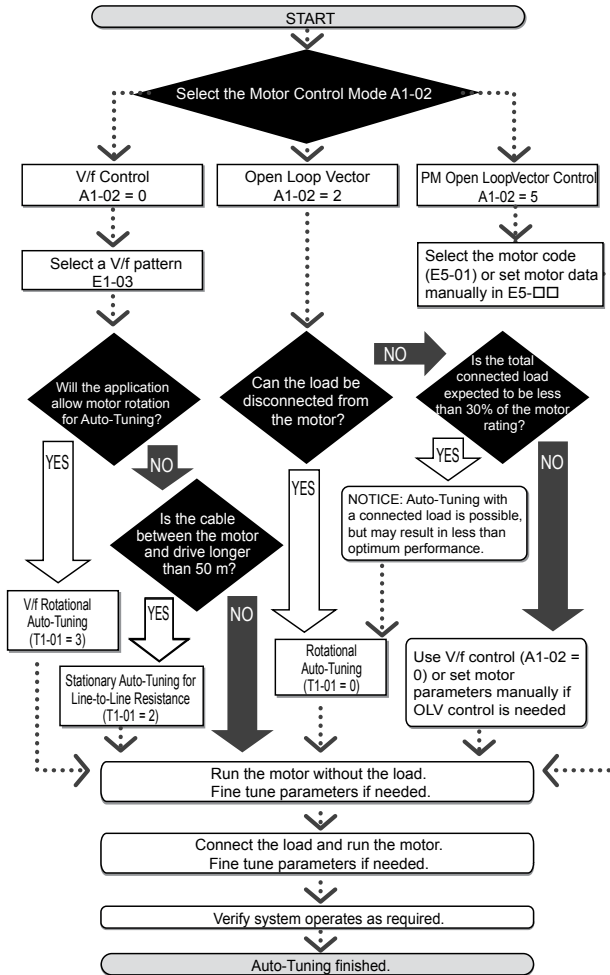

Figure 4.13 Auto-Tuning Selection

3. Enter the type of Auto-Tuning to parameter T1-01.

4. Enter the motor nameplate data.
5. Start the Auto-Tuning process when prompted by the drive.
6. If Auto-Tuning was successfully performed, do a test run without the load and make any necessary parameter adjustments.
7. If the test run was successful, do a test run with the load connected and make parameter adjustments if necessary.

## ◆ Auto-Tuning Example

The following example illustrates how to perform Rotational Auto-Tuning for Open Loop Vector Control (A1-02 = 2).

### ■ Set the Selected Type of Auto-Tuning













Step			Display/Result
1.	Turn on the power to the drive. The initial display appears.	→	
2.	Press the  key until the Auto-Tuning display appears.	→	
3.	Press  to begin setting parameters.	→	
4.	Press  to display the value for T1-01.	→	
5.	Press  to select the digit to edit.	→	
6.	Press  and set the drive to perform Rotational Auto-Tuning (00).	→	
7.	Save the setting by pressing .	→	
8.	The display automatically returns to the display shown in Step 3.	→	

### ■ Enter Data from the Motor Nameplate

After selecting the type of Auto-Tuning, enter the data required from the motor nameplate.

**Note:** These instructions continue from Step 8 in “Set the Selected Type of Auto-Tuning”.

## 4.7 Auto-Tuning

Step			Display/Result
1.	Press  to access the motor output power parameter T1-02.	→	
2.	Press  to view the default setting.	→	
3.	Press  to select the digit to edit.	→	
4.	Press  and enter the motor power nameplate data in kW.	→	
5.	Press  to save the setting.	→	
6.	The display automatically returns to the display in Step 1.	→	
7.	Repeat Steps 1 through 5 to set the following parameters: <ul style="list-style-type: none"> <li>• T1-03, Motor Rated Voltage</li> <li>• T1-04, Motor Rated Current</li> <li>• T1-05, Motor Base Frequency</li> <li>• T1-06, Number of Motor Poles</li> <li>• T1-07, Motor Base Frequency</li> </ul>	→	

- Note:**
1. For the details on each setting, [Refer to Input Data for Auto-Tuning on page 115.](#)
  2. For Stationary Auto-Tuning for Line-to-Line resistance only, set T1-02 and T1-04.

### ■ Starting Auto-Tuning

**WARNING!** *Sudden Movement Hazard.* The drive and motor may start unexpectedly during Auto-Tuning, which could result in death or serious injury. Ensure the area surrounding the drive motor and load are clear before proceeding with Auto-Tuning.





**WARNING!** *Electrical Shock Hazard.* High voltage will be supplied to the motor when Stationary Auto-Tuning is performed even with the motor stopped, which could result in death or serious injury. Do not touch the motor until Auto-Tuning has been completed.

**NOTICE:** *Rotational Auto-Tuning will not function properly if a holding brake is engaged on the load. Failure to comply could result in improper operation of the drive. Ensure the motor can freely spin before beginning Auto-Tuning.*

**NOTICE:** *Never perform Rotational Auto-Tuning for a motor connected to a load. Failure to comply could result in improper drive operation. If Rotational Auto-Tuning is performed for a motor coupled to a load, the motor parameters will be inaccurate and the motor may exhibit abnormal operation. Disconnect or decouple the motor from the load.*

Enter the required information from the motor nameplate. Press  to proceed to the Auto-Tuning start display.

- Note:** These instructions continue from Step 7 in “Enter Data from the Motor Nameplate”.

Step		Display/Result
1.	After setting T1-07 as illustrated in the previous section, press  and confirm the display is as described below:	
2.	Press  to activate Auto-Tuning. <b>DRV</b> flashes. <b>Note:</b> The first digit indicates which motor is undergoing Auto-Tuning (motor 1 or motor 2). The second digit indicates the type of Auto-Tuning being performed.	
3.	Auto-Tuning finishes in approximately one to two minutes.	

## ◆ Input Data for Auto-Tuning

The T1-□□ parameters are used to set the Auto-Tuning input data.

**Note:** For motors that are to be operated in the field weakening range, first perform the Auto-Tuning with the base data, i.e. the frequency at which the motor is operating with its rated voltage (base frequency). After Auto-Tuning is complete, change the maximum frequency E1-04 to the desired value.

### ■ T1-00: Motor 1/Motor 2 Selection

Selects the motor to be tuned when motor 1/2 switching is enabled, i.e., a digital input is set for function H1-□□ = 16. This parameter is not displayed if motor 1/2 switching is disabled.

No.	Name	Setting Range	Default
T1-00	Motor 1/2 Selection	1 or 2	1

#### Setting 1: Motor 1

Auto-Tuning automatically sets parameters E1-□□ and E2-□□ for motor 1.

#### Setting 2: Motor 2

Auto-Tuning automatically sets parameters E3-□□ and E4-□□ for motor 2. Make sure that motor 2 is connected to the drive for Auto-Tuning.

### ■ T1-01: Tuning Mode Selection

Sets the type of Auto-Tuning to be used. *Refer to Types of Auto-Tuning on page 109* for details on different types of Auto-Tuning.

No.	Name	Setting Range	Default
T1-01	Auto-Tuning Mode Selection	0, 2 (OLV) 2, 3 (V/f)	0 (OLV) 2 (V/f)

#### Setting 0: Rotating Auto-Tuning for Open Loop Vector Control

## 4.7 Auto-Tuning

### Setting 2: Stationary Auto-Tuning for Line-to-Line Resistance

### Setting 3: Rotating Auto-Tuning for V/f Control

#### ■ T1-02: Motor Rated Power

Used to set the motor rated power according to the motor nameplate value. For optimal performance, the motor rated power should be between 50 and 100% of the drive rating.

No.	Name	Setting Range	Default
T1-02	Motor Rated Power	0.00 to 650.00 kW	Determined by o2-04 and C6-01

#### ■ T1-03: Motor Rated Voltage (T1-01 = 0 or 3)

Used to set the motor rated voltage according to the motor nameplate value. If the motor is used above its base speed, enter the voltage at base speed here.

For higher tuning precision and better control performance, enter the motor no-load voltage here if known. The motor no-load voltage is referred as to the voltage needed to operate the motor under no-load condition at its rated speed. Refer to the motor data sheet.

No.	Name	Setting Range	Default
T1-03 </>	Motor Rated Voltage	0.0 to 255.5 V	200.0 V

<1> Values shown here are for 200 V class drives. Double values when using a 400 V class unit.

#### ■ T1-04: Motor Rated Current

Used to set the motor rated current according to the motor nameplate value. For optimal performance in OLV, the motor rated current should be between 50 and 100% of the drive rating. Enter the current at the motor base speed.

No.	Name	Setting Range	Default
T1-04	Motor Rated Current	10 to 200% of drive rated current	Determined by o2-04 and C6-01

#### ■ T1-05: Motor Rated Frequency (T1-01 = 0 or 3)

Used to set the motor rated frequency according to the motor nameplate value. If a motor with an extended speed range is used or the motor is used in the field weakening area, enter the base frequency here.

For higher tuning precision and better control performance, enter the motor no-load frequency here if known. The “no-load frequency” refers to the frequency needed to operate the motor under no-load condition at its rated speed. Refer to the motor data sheet.

No.	Name	Setting Range	Default
T1-05	Motor Base Frequency	0.0 to 400.0 Hz	60.0 Hz

### ■ T1-06: Number of Motor Poles (T1-01 = 0 or 3)

Used to set the number of motor poles according to the motor nameplate value.

No.	Name	Setting Range	Default
T1-06	Number of Motor Poles	2 to 48	4

### ■ T1-07: Motor Rated Speed (T1-01 = 0 or 3)

Used to set the motor rated speed according to the motor nameplate value. If a motor with an extended speed range is used or the motor is used in the field weakening area, enter the speed at base frequency here.

No.	Name	Setting Range	Default
T1-07	Motor Base Speed	0 to 24000 r/min	1750 r/min

### ■ T1-11: Motor Iron Loss (T1-01 = 3)

Provides iron loss information for determining the Energy Saving coefficient. If E2-10 has been changed and the power has been cycled, the value set to E2-10 will appear as the default in T1-11. If the value of T1-02 is not changed during Auto-Tuning data input, the drive will select a value that is typical for the motor power entered to T1-02.

No.	Name	Setting Range	Default
T1-11	Motor Iron Loss	0 to 65535 W	Determined by o2-04 and C6-01

# 4.8 No-Load Operation Test Run

## ◆ No-Load Operation Test Run

This section explains how to operate the drive with the motor uncoupled from the load during a test run.

### ■ Before Starting the Motor

Check the following items before operation:

- Ensure the area around the motor is safe.
- Ensure external emergency stop circuitry is working properly and other safety precautions have been taken.

### ■ During Operation

Check the following items during operation:

- The motor should rotate smoothly (i.e., no abnormal noise or oscillation).
- The motor should accelerate and decelerate smoothly.







### ■ No-Load Operation Instructions

The following example illustrates a test run procedure using the digital operator.

**Note:** Before starting the motor, set the frequency reference d1-01 to 6 Hz.

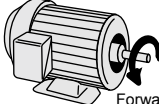
Step			Display/Result
1.	Turn on the power to the drive. The initial display appears.	→	
2.	Press the  key to select LOCAL. The LO/RE LED will turn on.	→	

## 4.8 No-Load Operation Test Run

	Step		Display/Result
	<p>3. Press  to give the drive a Run command. RUN will light and the motor will rotate at 6 Hz.</p>	→	 
	<p>4. Ensure the motor is rotating in the correct direction and no faults or alarms occur.</p>	→	<p>Motor</p>  <p>Forward</p>
	<p>5. If there is no error in step 4, press  to increase the frequency reference. Increase the frequency in 10 Hz increments verifying smooth operation results at all speeds. For each frequency, monitor the drive output current (U1-03) through the LED operator to confirm the current is well below the motor rated current. Example: 6 Hz → 60 Hz.</p>		
	<p>6. The drive should operate normally. Press  to stop the motor. RUN flashes until the motor comes to a complete stop.</p>	→	 

# 4.9 Test Run with Load Connected

---

## ◆ Test Run with the Load Connected

After performing a no-load test run connect the motor and proceed to run the motor and load together.

### ■ Notes on Connected Machinery

- Clear the area around the motor.
- The motor should come to a complete stop without problems.
- Connect the machinery.
- Fasten all installation screws properly. Check that the motor and connected machinery are held in place.
- Confirm that the Fast-stop circuit or mechanical safety measures operate correctly.
- Be ready to press the STOP button in case of emergency.

### ■ Checklist Before Operation

- The motor should rotate in the proper direction.
- The motor should accelerate and decelerate smoothly.

### ■ Operating the Motor under Loaded Conditions

Test run the application similarly to the no-load test procedure when connecting the machinery to the motor.

- Check monitor parameter U1-03 to ensure there is no overcurrent.
- If the application permits running the load in the reverse direction, try changing motor direction and the frequency reference while watching for abnormal motor oscillation or vibration.
- Correct any problems that occurs with hunting, oscillation, or other control-related issues.

## 4.10 Test Run Checklist

Review the checklist before performing a test run. Check each item that applies.

<input checked="" type="checkbox"/>	No.	Checklist	Page
<input type="checkbox"/>	1	Thoroughly read the manual before performing a test run.	—
<input type="checkbox"/>	2	Turn the power on.	92
<input type="checkbox"/>	3	Set the voltage for the power supply to E1-01.	166

Check the items that correspond to the control mode being used.

**WARNING!** Ensure start/stop and safety circuits are wired properly and in the correct state before energizing the drive. Failure to comply could result in death or serious injury from moving equipment. When programmed for 3-Wire control, a momentary closure on terminal S1 may cause the drive to start.

<input checked="" type="checkbox"/>	No.	Checklist	Page
V/f Control (A1-02 = 0)			
<input type="checkbox"/>	4	Select the best V/f pattern according to the application and motor characteristics. Example: If using a motor with a rated frequency of 60.0 Hz, set E1-03 to "1".	—
<input type="checkbox"/>	5	Perform Auto-Tuning for Energy Savings if using Energy Saving functions.	109
Open Loop Vector Control (A1-02 = 2)			
<input type="checkbox"/>	6	Uncouple the load from the motor when performing Rotational Auto-Tuning.	109
<input type="checkbox"/>	7	Perform Rotational Auto-Tuning.	109
<input type="checkbox"/>	8	The following data entered during Auto-Tuning should match the information written on the motor nameplate: <ul style="list-style-type: none"> <li>• motor rated output power (kW) → T1-02</li> <li>• rated voltage (V) → T1-03</li> <li>• rated current (A) → T1-04</li> <li>• base frequency (Hz) → T1-05</li> <li>• number of motor poles → T1-06</li> <li>• motor rotations per minutes (r/min) → T1-07</li> </ul>	—
PM Open Loop Vector Control (A1-02 = 5)			
<input type="checkbox"/>	9	Set permanent motor parameters E5-01 through E5-24	91

Proceed to the following checklist after checking items 4 through 9.

## 4.10 Test Run Checklist

<input checked="" type="checkbox"/>	No.	Checklist	Page
<input type="checkbox"/>	10	The <b>DRV</b> should illuminate after giving a run command.	—
<input type="checkbox"/>	11	To give a run command and frequency reference from the LED Digital Operator, press  to set to LOCAL. The LO/RE key lights while LOCAL is displayed.	85
<input type="checkbox"/>	12	If the motor rotates in the opposite direction during the test run, switch two of the drive output terminals (U/T1, V/T2, W/T3).	92
<input type="checkbox"/>	13	Select the correct duty rating (C6-01) for the application.	—
<input type="checkbox"/>	14	Set the correct values for the motor rated current (E2-01) and the motor protection selection (L1-01) to ensure motor thermal protection.	—
<input type="checkbox"/>	15	If the run command and frequency reference are provided via the control circuit terminals, set the drive for REMOTE and be sure the LO/RE light is out.	85
<input type="checkbox"/>	16	If the control circuit terminals should supply the frequency reference, select the correct voltage input signal level (0 to 10 V) or the correct current input signal level (4 to 20 mA or 0 to 20 mA).	85
<input type="checkbox"/>	17	Set the proper voltage to terminal A1. (0 to 10 V).	158
<input type="checkbox"/>	18	Set the proper current to terminal A2. (4 to 20 mA or 0 to 20 mA).	158
<input type="checkbox"/>	19	When current input is used, set H3-09 to “2” (4 to 20 mA) or “3” (0 to 20 mA) and set H3-10 to “0”.	—
<input type="checkbox"/>	20	When current input is used, switch the drive built-in DIP switch S1 from the V-side (OFF) to I-side (ON).	—
<input type="checkbox"/>	21	Set the minimum and maximum frequency references to the desired values. Make the following adjustments if the drive does not operate as expected: Gain adjustment: Set the maximum voltage/current signal and adjust the analog input gain (H3-03 for input A1, H3-11 for input A2) until the frequency reference value reaches the desired value. Bias adjustment: Set the minimum voltage/current signal and adjust the analog input bias (H3-04 for input A1, H3-12 for input A2) until the frequency reference value reaches the desired minimum value.	—



## Troubleshooting

This chapter provides descriptions of the drive faults, alarms, errors, related displays, and possible solutions. This chapter can also serve as a reference guide for tuning the drive during a trial run.

<b>5.1</b>	<b>DRIVE ALARMS, FAULTS, AND ERRORS.....</b>	<b>124</b>
<b>5.2</b>	<b>FAULT DETECTION.....</b>	<b>125</b>
<b>5.3</b>	<b>ALARM DETECTION.....</b>	<b>140</b>
<b>5.4</b>	<b>OPERATOR PROGRAMMING ERRORS.....</b>	<b>143</b>
<b>5.5</b>	<b>AUTO-TUNING FAULT DETECTION.....</b>	<b>144</b>
<b>5.6</b>	<b>DIAGNOSING AND RESETTING FAULTS.....</b>	<b>147</b>

# 5.1 Drive Alarms, Faults, and Errors

## ◆ Types of Alarms, Faults, and Errors

Table 5.1 Types of Alarms, Faults, and Errors

Type	Drive Responses to Alarms, Faults, and Errors
<b>Faults</b>	<p>When the drive detects a fault:</p> <ul style="list-style-type: none"> <li>• The digital operator displays text that indicates the specific fault and the ALM indicator LED remains lit until the fault is reset.</li> <li>• The fault interrupts drive output and the motor coasts to a stop.</li> <li>• Depending on the setting, the drive and motor may stop via different methods than listed.</li> <li>• If a digital output is programmed for fault output (H2-□□ = E), it will close if a fault occurs.</li> </ul> <p>When the drive detects a fault, it will remain inoperable until that fault has been reset. <i>Refer to <a href="#">Fault Reset Methods on page 147</a>.</i></p>
<b>Minor Faults and Alarms</b>	<p>When the drive detects an alarm or a minor fault:</p> <ul style="list-style-type: none"> <li>• The digital operator displays text that indicates the specific alarm or minor fault and the ALM indicator LED flashes.</li> <li>• The motor does not stop.</li> <li>• One of the multi-function contact outputs closes if set to be tripped by a minor fault (H2-□□ = 10), but not by an alarm.</li> <li>• The digital operator displays text indicating a specific alarm and ALM indicator LED flashes.</li> </ul> <p>Remove the cause of an alarm or minor fault to automatically reset.</p>
<b>Operation Errors</b>	<p>When parameter settings conflict with one another or do not match hardware settings (such as with an option card), it results in an operation error. When the drive detects an operation error:</p> <ul style="list-style-type: none"> <li>• The digital operator displays text that indicates the specific error.</li> <li>• Multi-function contact outputs do not operate.</li> </ul> <p>When the drive detects an operation error, it will not operate the motor until the error has been reset. Correct the settings that caused the operation error to reset.</p>
<b>Tuning Errors</b>	<p>Tuning errors occur while performing Auto-Tuning. When the drive detects a tuning error:</p> <ul style="list-style-type: none"> <li>• The digital operator displays text indicating the specific error.</li> <li>• Multi-function contact outputs do not operate.</li> <li>• Motor coasts to stop.</li> <li>• Remove the cause of the error and repeat the Auto-Tuning process.</li> </ul>

## 5.2 Fault Detection

### ◆ Fault Displays, Causes, and Possible Solutions

Table 5.2 Detailed Fault Displays, Causes, and Possible Solutions

LED Operator Display		Fault Name
<i>bUS</i>	bUS	Option Communication Error
		<ul style="list-style-type: none"> <li>• After establishing initial communication, the connection was lost.</li> <li>• Only detected when the run command frequency reference is assigned to an option card.</li> </ul>
<b>Cause</b>		<b>Possible Solution</b>
No signal received from the PLC.		<ul style="list-style-type: none"> <li>• Check for faulty wiring.</li> </ul>
The communication cable is faulty or a short circuit exists.		<ul style="list-style-type: none"> <li>• Correct the wiring.</li> <li>• Check for loose wiring and short circuits. Repair as needed.</li> </ul>
A communications data error occurred due to noise.		<ul style="list-style-type: none"> <li>• Check the various options available to minimize the effects of noise.</li> <li>• Counteract noise in control circuit, main circuit, and ground wiring.</li> <li>• Ensure that other equipment such as switches or relays do not cause noise and use surge suppressors if required.</li> <li>• Use cables recommended by Yaskawa or another type of shielded line. Ground the shield on the controller side or on the drive input power side.</li> <li>• Separate all wiring for communications devices from drive input power lines. Install an EMC noise filter to the input side of the drive input power.</li> </ul>
The option card is damaged.		<ul style="list-style-type: none"> <li>• Replace the option card if there are no problems with the wiring and the error continues to occur.</li> </ul>
The option card is not properly connected to the drive.		<ul style="list-style-type: none"> <li>• The connector pins on the option card are not properly lined up with the connector pins on the drive.</li> <li>• Reinstall the option card.</li> </ul>
<i>CE</i>	CE	MEMOBUS/Modbus Communication Error
		Control data was not received for the CE detection time set to H5-09.
<b>Cause</b>		<b>Possible Solution</b>
Faulty communications wiring, or a short circuit exists.		<ul style="list-style-type: none"> <li>• Check for faulty wiring.</li> <li>• Correct the wiring.</li> <li>• Check for loose wiring and short circuits. Repair as needed.</li> </ul>

## 5.2 Fault Detection

A communications data error occurred due to noise.		<ul style="list-style-type: none"> <li>• Check the various options available to minimize the effects of noise.</li> <li>• Counteract noise in control circuit, main circuit, and ground wiring.</li> <li>• Use Yaskawa-recommended cables, or another type of shielded line. Ground the shield on the controller side or on the drive input power side.</li> <li>• Ensure that other equipment such as switches or relays do not cause noise and use surge suppressors if required.</li> <li>• Separate all wiring for communications devices from drive input power lines. Install an EMC noise filter to the input side of the drive input power.</li> </ul>
$\text{CF}$	CF	Control Fault A torque limit was reached continuously for three seconds or longer during a ramp to stop while in Open Loop Vector Control.
$\text{CoF}$	CoF	Current Offset Fault There is a problem with the current detection circuit or the drive attempted to start a coasting PM motor.
<b>Cause</b>		<b>Possible Solution</b>
While the drive automatically adjusted the current offset, the calculated value exceeded the allowable setting range. This problem may occur when attempting to restart a coasting PM motor.		Enable Speed Search at start (b3-01 = 1). Use the multi-function terminals to execute External Speed Search 1 and 2 (H1-□□ = 61 or 62). <b>Note:</b> When using a PM motor, both External Speed Search 1 and 2 perform the same operation.
$\text{CPF02}$	CPF02	A/D Conversion Error An A/D conversion error occurred.
$\text{CPF03}$	CPF03	PWM Data Error There is a problem with the PWM data.
$\text{CPF06}$	CPF06	EEPROM Data Error There is an error in the data saved to EEPROM.
<b>Cause</b>		<b>Possible Solution</b>
Control circuit is damaged.		Cycle power to the drive. If the problem continues, replace the drive.
The power supply was switched off when parameters were written (e.g., using a communications option card).		Reinitialize the drive (A1-03).
$\text{CPF07}$	CPF07	Terminal Board Communications Error A communication error occurred at the terminal board.
$\text{CPF08}$	CPF08	EEPROM Serial Communication Fault EEPROM communications are not functioning properly.
$\text{CPF11}$	CPF11	RAM Fault
$\text{CPF12}$	CPF12	FLASH Memory Fault Problem with the ROM (FLASH memory).



<i>CPF13</i>	CPF13	Watchdog Circuit Exception Self-diagnostics problem.
<i>CPF14</i>	CPF14	Control Circuit Fault CPU error (CPU operates incorrectly due to noise, etc.)
<i>CPF16</i>	CPF16	Clock Fault Standard clock error.
<i>CPF17</i>	CPF17	Timing Fault A timing error occurred during an internal process.
<i>CPF18</i>	CPF18	Control Circuit Fault CPU error. Non-Maskable Interrupt (An unusual interrupt was triggered by noise, etc.)
<i>CPF19</i>	CPF19	Control Circuit Fault CPU error (Manual reset due to noise, etc.)
<i>CPF20 or CPF21</i>	CPF20 or CPF21	One of the following faults occurred: RAM fault, FLASH memory error, watchdog circuit exception, clock error <ul style="list-style-type: none"> <li>• RAM fault.</li> <li>• FLASH memory error (ROM error).</li> <li>• Watchdog circuit exception (self-diagnostic error).</li> <li>• Clock error.</li> </ul>
<i>CPF22</i>	CPF22	A/D Conversion Fault A/D conversion error.
<i>CPF23</i>	CPF23	PWM Feedback Fault PWM feedback error.
<i>CPF24</i>	CPF24	Drive Capacity Signal Fault Entered a capacity that does not exist. (Checked when the drive is powered up.)
<b>Cause</b>		<b>Possible Solution</b>
Hardware is damaged.		Replace the drive.
<i>dEv</i>	dEv	Speed Deviation (for Simple V/f with PG) According to the pulse input (RP), the speed deviation is greater than the setting in F1-10 for longer than the time set to F1-11.
<i>dWFL</i>	dWFL	DriveWorksEZ Fault
<i>dWAL</i>	dWAL	DriveWorksEZ Program Error Output
<i>EF0</i>	EF0	Option Card External Fault An external fault condition is present.
<b>Cause</b>		<b>Possible Solution</b>

## 5.2 Fault Detection

An external fault was received from the PLC with other than F6-03 = 3 “alarm only” (the drive continued to run after external fault).		<ul style="list-style-type: none"> <li>Remove the cause of the external fault.</li> <li>Remove the external fault input from the PLC.</li> </ul>
Problem with the PLC program.		Check the PLC program and correct problems.
<i>EF1</i>	EF1	External Fault (input terminal S1)
		External fault at multi-function input terminal S1.
<i>EF2</i>	EF2	External Fault (input terminal S2)
		External fault at multi-function input terminal S2.
<i>EF3</i>	EF3	External Fault (input terminal S3)
		External fault at multi-function input terminal S3.
<i>EF4</i>	EF4	External Fault (input terminal S4)
		External fault at multi-function input terminal S4.
<i>EF5</i>	EF5	External Fault (input terminal S5)
		External fault at multi-function input terminal S5.
<i>EF6</i>	EF6	External Fault (input terminal S6)
		External fault at multi-function input terminal S6.
<i>EF7</i>	EF7	External Fault (input terminal S7)
		External fault at multi-function input terminal S7
<b>Cause</b>		<b>Possible Solution</b>
An external device has tripped an alarm function.		Remove the cause of the external fault and reset the fault.
Wiring is incorrect.		<ul style="list-style-type: none"> <li>Ensure the signal lines have been connected properly to the terminals assigned for external fault detection (H1-□□ = 20 to 2F).</li> <li>Reconnect the signal line.</li> </ul>
Incorrect setting of multi-function contact inputs.		<ul style="list-style-type: none"> <li>Check if the unused terminals set for H1-□□ = 20 to 2F (External Fault).</li> <li>Change the terminal settings.</li> </ul>
<i>Err</i>	Err	EEPROM Write Error
		Data does not match the EEPROM being written to.
<i>FbH</i>	FbH	Excessive PID Feedback
		PID feedback input is greater than the level set b5-36 for longer than the time set to b5-37. To enable fault detection, set b5-12 = “2” or “5”.
<i>FbL</i>	FbL	PID Feedback Loss
		This fault occurs when PID Feedback Loss Detection is programmed to fault (b5-12 = 2) and the PID Feedback < PID Feedback Loss Detection Level (b5-13) for the PID Feedback Loss Detection Time (b5-14).

$\underline{GF}$	GF	Ground Fault
		<ul style="list-style-type: none"> <li>Current shorted to ground exceeded 50% of rated current on output side of the drive.</li> <li>Setting L8-09 to 1 enables ground fault detection in models 5.5 kW or larger.</li> </ul>
<b>Cause</b>		<b>Possible Solution</b>
Motor insulation is damaged.		<ul style="list-style-type: none"> <li>Check the insulation resistance of the motor.</li> <li>Replace the motor.</li> </ul>
A damaged motor cable is creating a short circuit.		<ul style="list-style-type: none"> <li>Check the motor cable.</li> <li>Remove the short circuit and turn the power back on.</li> </ul>
The leakage current at the drive output is too high.		<ul style="list-style-type: none"> <li>Check the resistance between the cable and the ground terminal ⊕.</li> <li>Replace the cable.</li> </ul>
The drive started to run during Current Offset Fault or while coasting to a stop.		<ul style="list-style-type: none"> <li>Reduce the carrier frequency.</li> <li>Reduce the amount of stray capacitance.</li> </ul>
Hardware problem.		<ul style="list-style-type: none"> <li>The value set exceeds the allowable setting range while the drive automatically adjusts the current offset (this happens only attempting to restart a PM motor that is coasting to stop).</li> <li>Enable Speed Search at start (b3-01 = 1).</li> <li>Perform Speed Search 1 or 2 (H1-□□ = 61 or 62) via one of the external terminals. <b>Note:</b> Speed Search 1 and 2 are the same when using PM OLV.</li> </ul>
Replace the drive.		<ul style="list-style-type: none"> <li>Replace the drive.</li> </ul>
$\underline{LF}$	LF	Output Phase Loss
		<ul style="list-style-type: none"> <li>Phase loss on the output side of the drive.</li> <li>Phase Loss Detection is enabled when L8-07 is set to “1” or “2”.</li> </ul>
<b>Cause</b>		<b>Possible Solution</b>
The output cable is disconnected.		<ul style="list-style-type: none"> <li>Check for wiring errors and ensure the output cable is connected properly.</li> <li>Correct the wiring.</li> </ul>
The motor winding is damaged.		<ul style="list-style-type: none"> <li>Check the resistance between motor lines.</li> <li>Replace the motor if the winding is damaged.</li> </ul>
The output terminal is loose.		<ul style="list-style-type: none"> <li>Apply the tightening torque specified in this manual to fasten the terminals. <i>Refer to Wire Size and Torque Specifications on page 68.</i></li> </ul>
The motor being used is less than 5% of the drive rated current.		Check the drive and motor capacities.
An output transistor is damaged.		Replace the drive.
A single-phase motor is being used.		The drive being used cannot operate a single phase motor.
$\underline{LF2}$	LF2	Output current imbalance
		One or more of the phases in the output current is lost.
<b>Cause</b>		<b>Possible Solution</b>
Phase loss has occurred on the output side of the drive.		<ul style="list-style-type: none"> <li>Check for faulty wiring or poor connections on the output side of the drive.</li> <li>Correct the wiring.</li> </ul>

## 5.2 Fault Detection

Terminal wires on the output side of the drive are loose.	Apply the tightening torque specified in this manual to fasten the terminals. <i>Refer to Wire Size and Torque Specifications on page 68.</i>
No signal displays from the gate driver board.	Replace the drive. Contact Yaskawa for assistance.
Motor impedance or motor phases are uneven.	<ul style="list-style-type: none"> <li>Measure the line-to-line resistance for each motor phase. Ensure all values are the same.</li> <li>Replace the motor. Contact Yaskawa for assistance.</li> </ul>
 nSE	CAN Open Node Setup Error
<b>Cause</b>	<b>Possible Solution</b>
The node setup digital input was activated during Run.	<ul style="list-style-type: none"> <li>Perform node ID setup when no RUN command is active.</li> <li>Do not enter a Run command until node address setup is complete and the terminal is released.</li> </ul>
 oC	Overcurrent
	Drive sensors have detected an output current greater than the specified overcurrent level.
<b>Cause</b>	<b>Possible Solution</b>
The motor has been damaged due to overheating or the motor insulation is damaged.	<ul style="list-style-type: none"> <li>Check the insulation resistance.</li> <li>Replace the motor.</li> </ul>
One of the motor cables has shorted out or there is a grounding problem.	<ul style="list-style-type: none"> <li>Check the motor cables.</li> <li>Remove the short circuit and power the drive back up.</li> <li>Check the resistance between the motor cables and the ground terminal(⊕).</li> <li>Replace damaged cables.</li> </ul>
The load is too heavy.	<ul style="list-style-type: none"> <li>Measure the current flowing into the motor.</li> <li>Replace the drive with a larger capacity unit if the current value exceeds the rated current of the drive.</li> <li>Determine if there is sudden fluctuation in the current level.</li> <li>Reduce the load to avoid sudden changes in the current level or switch to a larger drive.</li> </ul>
The acceleration or deceleration times are too short.	<p>Calculate the torque needed during acceleration relative to the load inertia and the specified acceleration time. If the right amount of torque cannot be set, make the following changes:</p> <ul style="list-style-type: none"> <li>Increase the acceleration time (C1-01, -03, -05, -07)</li> <li>Increase the S-curve characteristics (C2-01 through C2-04)</li> <li>Increase the capacity of the drive.</li> </ul>
The drive is attempting to operate a specialized motor or a motor larger than the maximum size allowed.	<ul style="list-style-type: none"> <li>Check the motor capacity.</li> <li>Ensure that the rated capacity of the drive is greater than or equal to the capacity rating found on the motor nameplate.</li> </ul>
Magnetic contactor (MC) on the output side of the drive has turned on or off.	Set up the operation sequence so that the MC is not tripped while the drive is outputting current.

V/f setting is not operating as expected.	<ul style="list-style-type: none"> <li>• Check the ratios between the voltage and frequency.</li> <li>• Set parameter E1-04 through E1-10 appropriately. Set E3-04 through E3-10 when using a second motor.</li> <li>• Lower the voltage if it is too high relative to the frequency.</li> </ul>	
Excessive torque compensation.	<ul style="list-style-type: none"> <li>• Check the amount of torque compensation.</li> <li>• Reduce the torque compensation gain (C4-01) until there is no speed loss and less current.</li> </ul>	
Drive fails to operate properly due to noise interference.	<ul style="list-style-type: none"> <li>• Review the possible solutions provided for handling noise interference.</li> <li>• Review the section on handling noise interference and check the control circuit lines, main circuit lines and ground wiring.</li> </ul>	
Overexcitation gain is set too high.	<ul style="list-style-type: none"> <li>• Check if fault occurs simultaneously to overexcitation function operation.</li> <li>• Consider motor flux saturation and reduce the value of n3-13 (Overexcitation Deceleration Gain).</li> </ul>	
Run command applied while motor was coasting.	<ul style="list-style-type: none"> <li>• Enable Speed Search at start (b3-01 = "1").</li> <li>• Program the Speed Search command input through one of the multi-function contact input terminals (H1-□□ = "61" or "62").</li> </ul>	
The wrong motor code has been entered for PM Open Loop Vector (Yaskawa motors only).	Enter the correct motor code to E5-01 to indicate that a PM motor is connected.	
The motor control method and motor do not match.	Check which motor control method the drive is set to (A1-02). <ul style="list-style-type: none"> <li>• For IM motors, set A1-02 = "0" or "2".</li> <li>• For PM motors, set A1-02 = "5".</li> </ul>	
The motor cable is too long	Use a larger drive.	
<i>oFA00</i>	oFA00	Option Card Fault (Port A)
		The option card is incompatible with the drive.
<i>oFA01</i>	oFA01	Option Card Fault (Port A)
		Replace the option card.
<i>oFA03</i>	oFA03	Option Card Fault (port A)
		Option card self-diagnostic error
<i>oFA04</i>	oFA04	Option Card Fault (port A)
		An error occurred attempting to write to the option card memory.
<i>oFA30<sub>10</sub></i> <i>oFA43</i>	oFA30 to oFA43	Option Card Fault (port A)
		Communication ID error
<i>oH</i>	oH	Heatsink Overheat
		The temperature of the heatsink exceeded the value set to L8-02. Default value for L8-02 is determined by drive capacity (o2-04).
<b>Cause</b>		<b>Possible Solution</b>

## 5.2 Fault Detection

Surrounding temperature is too high.		<ul style="list-style-type: none"> <li>• Check the temperature surrounding the drive. Verify temperature is within drive specifications.</li> <li>• Improve the air circulation within the enclosure panel.</li> <li>• Install a fan or air conditioner to cool the surrounding area.</li> <li>• Remove anything near the drive that might be producing excessive heat.</li> </ul>
Load is too heavy.		<ul style="list-style-type: none"> <li>• Measure the output current.</li> <li>• Decrease the load.</li> <li>• Lower the carrier frequency (C6-02).</li> </ul>
Internal cooling fan is stopped.		<ul style="list-style-type: none"> <li>• Replace the cooling fan. .</li> <li>• After replacing the drive, reset the cooling fan maintenance parameter (o4-03 = "0").</li> </ul>
<i>oH1</i>	oH1	Overheat 1 (Heatsink Overheat) The temperature of the heatsink has exceeded 10 °C plus the default value of L8-02.
<b>Cause</b>		<b>Possible Solution</b>
Surrounding temperature is too high.		<ul style="list-style-type: none"> <li>• Check the temperature surrounding the drive.</li> <li>• Improve the air circulation within the enclosure panel.</li> <li>• Install a fan or air conditioner to cool the surrounding area.</li> <li>• Remove anything near the drive that might be producing excessive heat.</li> </ul>
Load is too heavy.		<ul style="list-style-type: none"> <li>• Measure the output current.</li> <li>• Lower the carrier frequency (C6-02).</li> <li>• Reduce the load.</li> </ul>
The internal cooling fan has reached its performance life or has malfunctioned.		<ul style="list-style-type: none"> <li>• Check the maintenance time for the cooling fan (U4-04).</li> <li>• If U4-04 exceeds 90%, replace the cooling fan. .</li> <li>• After replacing fan, reset the fan maintenance time (o4-03 = "0").</li> </ul>
Current flowing to control circuit terminal +V exceeded the tolerance level.		<ul style="list-style-type: none"> <li>• Check the current level of the terminal.</li> <li>• Set the current to the control circuit terminal to be 20 mA or less.</li> </ul>
<i>oH3</i>	oH3	Motor Overheat Alarm (PTC Input) <ul style="list-style-type: none"> <li>• The motor overheat signal to analog input terminal A1 or A2 exceeded the alarm detection level.</li> <li>• Detection requires multi-function analog input H3-02 or H3-10 be set to "E".</li> </ul>
<i>oH4</i>	oH4	Motor Overheat Fault (PTC Input) <ul style="list-style-type: none"> <li>• The motor overheat signal to analog input terminal A1 or A2 exceeded the fault detection level.</li> <li>• Detection requires that multi-function analog input H3-02 or H3-10 = "E".</li> </ul>
<b>Cause</b>		<b>Possible Solution</b>

Motor has overheated.		<ul style="list-style-type: none"> <li>• Check the size of the load, the accel/decel times and the cycle times.</li> <li>• Decrease the load.</li> <li>• Increase the acceleration and deceleration times (C1-01 through C1-08).</li> </ul>
		<ul style="list-style-type: none"> <li>• Adjust the preset V/f pattern (E1-04 through E1-10). This will mainly involve reducing E1-08 and E1-10. Be careful not to lower E1-08 and E1-10 excessively because this reduces load tolerance at low speeds</li> <li>• Check the motor-rated current.</li> <li>• Enter the motor-rated current as indicated on the motor nameplate (E2-01).</li> <li>• Ensure the motor cooling system is operating normally.</li> <li>• Repair or replace the motor cooling system.</li> </ul>
oL1	oL1	<p>Motor Overload</p> <p>The electrothermal sensor tripped overload protection.</p>
<b>Cause</b>		<b>Possible Solution</b>
Load is too heavy.		Reduce the load.
Cycle times are too short during acceleration and deceleration.		Increase the acceleration and deceleration times (C1-01 through C1-08).
<ul style="list-style-type: none"> <li>• Drive overloaded at low speeds.</li> <li>• Overload may occur at low speeds when using a general-purpose motor, even if operating within the rated current limitation.</li> </ul>		<ul style="list-style-type: none"> <li>• Reduce the load.</li> <li>• Increase the speed.</li> <li>• If the drive is supposed to operate at low speeds, either increase the motor capacity or use a motor specifically designed to operate with the drive.</li> </ul>
Although a special type of motor is being used, the motor protection selection is set for a general-purpose motor (L1-01 = 1).		Set L1-01 = "2".
Voltage is too high for the V/f characteristics.		<ul style="list-style-type: none"> <li>• Adjust the user set V/f patterns (E1-04 through E1-10). Parameters E1-08 and E1-10 may need to be reduced.</li> <li>• If E1-08 and E1-10 are set too high, there may be very little load tolerance at low speed.</li> </ul>
The wrong motor-rated current is set to E2-01.		<ul style="list-style-type: none"> <li>• Check the motor-rated current.</li> <li>• Enter the value written on the motor nameplate to parameter E2-01.</li> </ul>
The maximum frequency for the drive input power is set too low.		<ul style="list-style-type: none"> <li>• Check the rated frequency indicated on the motor nameplate.</li> <li>• Enter the rated frequency to E1-06 (Base Frequency).</li> </ul>
Multiple motors are running off the same drive.		Disable the Motor Protection function (L1-01 = "0") and install a thermal relay to each motor.
The electrical thermal protection characteristics and motor overload characteristics do not match.		<ul style="list-style-type: none"> <li>• Check the motor characteristics.</li> <li>• Correct the value set to L1-01 (Motor Protection Function).</li> <li>• Install an external thermal relay.</li> </ul>
The electrical thermal relay is operating at the wrong level.		<ul style="list-style-type: none"> <li>• Check the current rating listed on the motor nameplate.</li> <li>• Check the value set for the motor-rated current (E2-01).</li> </ul>

## 5.2 Fault Detection

Motor overheated by overexcitation operation.		<ul style="list-style-type: none"> <li>Overexcitation increases the motor losses and the motor temperature. If applied too long, motor damage can occur. Prevent excessive overexcitation operation or apply proper cooling to the motor</li> <li>Reduce the excitation deceleration gain (n3-13).</li> <li>Set L3-04 (Stall Prevention during Deceleration) to a value other than 4.</li> </ul>		
Speed Search related parameters are not set to the proper values.		<ul style="list-style-type: none"> <li>Check values set to Speed Search related parameters.</li> <li>Adjust the Speed Search current and Speed Search deceleration times (b3-02 and b3-03 respectively).</li> <li>After Auto-Tuning, enable Speed Estimation Type Search (b3-24 = "1").</li> </ul>		
Output current fluctuation due to input phase loss		Check the power supply for phase loss.		
<table border="1" style="display: inline-table; vertical-align: middle;"> <tr> <td style="text-align: center;">oL2</td> <td style="text-align: center;">oL2</td> </tr> </table>	oL2	oL2	oL2	Drive Overload
	oL2	oL2		
The thermal sensor of the drive triggered overload protection.				
<b>Cause</b>		<b>Possible Solution</b>		
Load is too heavy.		Reduce the load.		
Cycle times are too short during acceleration and deceleration.		Increase the settings for the acceleration and deceleration times (C1-01 through C1-08).		
Voltage is too high for the V/f characteristics.		<ul style="list-style-type: none"> <li>Adjust the preset V/f pattern (E1-04 through E1-10). This will mainly involve reducing E1-08 and E1-10.</li> <li>Be careful not to lower E1-08 and E1-10 excessively because this reduces load tolerance at low speeds.</li> </ul>		
Drive capacity is too small.		Replace the drive with a larger model.		
Overload occurred when operating at low speeds.		<ul style="list-style-type: none"> <li>Reduce the load when operating at low speeds.</li> <li>Replace the drive with a model that is one frame size larger.</li> <li>Lower the carrier frequency (C6-02).</li> </ul>		
Excessive torque compensation.		Reduce the torque compensation gain (C4-01) until there is no speed loss but less current.		
Speed Search related parameters are not set correctly.		<ul style="list-style-type: none"> <li>Check the settings for all Speed Search related parameters.</li> <li>Adjust the current used during Speed Search and the Speed Search deceleration time (b3-03 and b3-02 respectively).</li> <li>After Auto-Tuning the drive, enable the Speed Search Estimation Type (b3-24 = "1").</li> </ul>		
Output current fluctuation due to input phase loss		Check the power supply for phase loss.		
<table border="1" style="display: inline-table; vertical-align: middle;"> <tr> <td style="text-align: center;">oL3</td> <td style="text-align: center;">oL3</td> </tr> </table>	oL3	oL3	oL3	Overtorque Detection 1
	oL3	oL3		
The current has exceeded the value set for torque detection (L6-02) for longer than the allowable time (L6-03).				
<table border="1" style="display: inline-table; vertical-align: middle;"> <tr> <td style="text-align: center;">oL4</td> <td style="text-align: center;">oL4</td> </tr> </table>	oL4	oL4	oL4	Overtorque Detection 2
	oL4	oL4		
The current has exceeded the value set for Overtorque Detection 2 (L6-05) for longer than the allowable time (L6-06).				

<i>oL5</i>	oL5	Mechanical Weakening Detection 1
		Overtorque occurred, matching the conditions specified in L6-08.
<i>oL7</i>	oL7	High-Slip Braking oL
		The output frequency stayed constant for longer than the time set in n3-04 during High-slip Braking.
<i>oPr</i>	oPr	External Digital Operator Connection Fault
		<ul style="list-style-type: none"> <li>• The external operator has been disconnected from the drive.</li> <li>• <b>Note:</b> An oPr fault will occur when all of the following conditions are true:</li> <li>• Output is interrupted when the operator is disconnected (o2-06 = 1).</li> <li>• The run command is assigned to the operator (b1-02 = 0 and LOCAL has been selected).</li> </ul>
<i>oS</i>	oS	Overspeed (Simple V/f with PG)
		Pulse input (RP) indicates that motor speed feedback exceeded F1-08 setting.
<i>ov</i>	ov	Overvoltage
		Voltage in the DC bus has exceeded the overvoltage detection level.
		<ul style="list-style-type: none"> <li>• For 200 V class: approximately 410 V</li> <li>• For 400 V class: approximately 820 V (740 V when E1-01 is less than 400)</li> </ul>
<b>Cause</b>		<b>Possible Solution</b>
Deceleration time is too short and regenerative energy flows from the motor into the drive.		<ul style="list-style-type: none"> <li>• Increase the deceleration time (C1-02, -04, -06, -08).</li> <li>• Install a braking resistor or a dynamic braking resistor unit.</li> <li>• Enable stall prevention during deceleration (L3-04 = "1"). Stall prevention is enabled as the default setting.</li> </ul>
Fast acceleration time causes the motor to overshoot the speed reference.		<ul style="list-style-type: none"> <li>• Check if sudden drive acceleration triggers an overvoltage alarm.</li> <li>• Increase the acceleration time.</li> <li>• Use longer S-curve acceleration and deceleration times.</li> </ul>
Excessive braking load.		The braking torque was too high, causing regenerative energy to charge the DC bus. Reduce the braking torque, use a braking option, or lengthen decel time.
Surge voltage entering from the drive input power.		Install a DC reactor. <b>Note:</b> Voltage surge can result from thyristor convertor and phase advancing capacitor using same drive main input power supply.
Ground fault in the output circuit causing the DC bus capacitor to overcharge.		<ul style="list-style-type: none"> <li>• Check the motor wiring for ground faults.</li> <li>• Correct grounding shorts and turn the power back on.</li> </ul>
Improper Setting of Speed Search related parameters. (Includes Speed Search after a momentary power loss and after a fault restart.)		<ul style="list-style-type: none"> <li>• Check the settings for Speed Search related parameters.</li> <li>• Enable Speed Search Retry function (b3-19 greater than or equal to 1 to 10).</li> <li>• Adjust the current level during Speed Search and the deceleration time (b3-02 and b3-03 respectively).</li> <li>• Perform Line-to-Line Resistance Auto-Tuning and then enable Speed Estimation Type Speed Search (b3-24 = "1").</li> </ul>

## 5.2 Fault Detection

Excessive regeneration when overshoot occurs after acceleration.		<ul style="list-style-type: none"> <li>• Enable the Overvoltage Suppression function (L3-11 = “1”).</li> <li>• Lengthen the S-curve at acceleration end.</li> </ul>
Drive input power voltage is too high.		<ul style="list-style-type: none"> <li>• Check the voltage.</li> <li>• Lower drive input power voltage within the limits listed in the specifications.</li> </ul>
The dynamic braking transistor is damaged.		Replace the drive.
The braking transistor is wired incorrectly.		<ul style="list-style-type: none"> <li>• Check braking transistor wiring for errors.</li> <li>• Properly rewire the braking resistor device.</li> </ul>
Drive fails to operate properly due to noise interference.		<ul style="list-style-type: none"> <li>• Review the list of possible solutions provided for controlling noise.</li> <li>• Review the section on handling noise interference and check the control circuit lines, main circuit lines and ground wiring.</li> </ul>
Load inertia has been set incorrectly.		<ul style="list-style-type: none"> <li>• Check the load inertia settings when using KEB, overvoltage suppression or Stall Prevention during deceleration.</li> <li>• Adjust L3-25 (Load Inertia Ratio) in accordance with the load.</li> </ul>
Braking function is being used in PM Open Loop Vector Control.		Connect a braking resistor.
Motor hunting occurs.		<ul style="list-style-type: none"> <li>• Adjust the parameters that control hunting.</li> <li>• Set the hunting prevention gain (n1-02).</li> <li>• Adjust the AFR time constant 1 (n2-02) and the AFR time constant 2 (n2-03) when in OLV Control.</li> <li>• Use parameters n8-45 (PM Speed Feedback Detection Suppression Gain) and n8-47 (Pull-In Current Compensation Time Constant).</li> </ul>
$PF$	PF	Input Phase Loss
		Drive input power has an open phase or has a large imbalance of voltage between phases. Detected when L8-05 = 1 (enabled).
<b>Cause</b>		<b>Possible Solution</b>
There is phase loss in the drive input power.		<ul style="list-style-type: none"> <li>• Check for wiring errors in the main circuit drive input power.</li> <li>• Correct the wiring.</li> </ul>
There is loose wiring in the drive input power terminals.		<ul style="list-style-type: none"> <li>• Ensure the terminals are tightened properly.</li> <li>• Apply the tightening torque specified in this manual to fasten the terminals.</li> </ul>
There is excessive fluctuation in the drive input power voltage.		<ul style="list-style-type: none"> <li>• Check the voltage from the drive input power.</li> <li>• Review the possible solutions for stabilizing the drive input power.</li> <li>• Disable Input Phase Loss Detection (L8-05 = “0”). PF is detected if DC bus ripple is too high. If it is disabled, there is no fault but the ripple is still too high, thereby the capacitors are stressed more and lose lifetime.</li> </ul>
There is poor balance between voltage phases.		<ul style="list-style-type: none"> <li>• Stabilize drive input power or disable phase loss detection.</li> </ul>

The main circuit capacitors are worn.		<ul style="list-style-type: none"> <li>Check the maintenance time for the capacitors (U4-05).</li> <li>Replace the drive if U4-05 is greater than 90%.</li> </ul>
$PGo$	PGo	PG Disconnect (for Simple V/f with PG)
		No PG pulses are received for longer than the time set to F1-14.
$rH$	rH	Braking Resistor Overheat
		Braking resistor protection was triggered. Fault detection is enabled when L8-01 = 1 (disabled as a default).
<b>Cause</b>		<b>Possible Solution</b>
Deceleration time is too short and excessive regenerative energy is flowing back into the drive.		<ul style="list-style-type: none"> <li>Check the load, deceleration time and speed.</li> <li>Reduce the load.</li> <li>Increase the acceleration and deceleration times (C1-01 through C1-08).</li> <li>Replace the braking option with a larger device that can handle the power that is discharged.</li> </ul>
Excessive braking inertia.		Recalculate braking load and braking power. Then try reducing the braking load and checking the braking resistor settings and improve braking capacity.
The proper braking resistor has not been installed.		<ul style="list-style-type: none"> <li>Check the specifications and conditions for the braking resistor device.</li> <li>Select the optimal braking resistor.</li> </ul>
<b>Note:</b> The magnitude of the braking load trips the braking resistor overheat alarm, NOT the surface temperature. Using the braking resistor more frequently than its rating trips the alarm even when the braking resistor surface is not very hot.		
$rr$	rr	Dynamic Braking Transistor
		The built-in dynamic braking transistor failed.
<b>Cause</b>		<b>Possible Solution</b>
The braking transistor is damaged.		<ul style="list-style-type: none"> <li>Cycle power to the drive and check if the fault reoccurs. <i>Refer to Diagnosing and Resetting Faults on page 147.</i></li> <li>Replace the drive if the fault continues.</li> </ul>
The control circuit is damaged.		
$SEr$	SEr	Too Many Speed Search Restarts
		The number of speed search restarts exceeded the number set to b3-19.
$STo$	STo	Motor Pull Out or Step Out Detection
		Motor pull out or step out has occurred. Motor has exceeded its pull out torque.
$UL3$	UL3	Undertorque Detection 1
		The current has fallen below the minimum value set for torque detection (L6-02) for longer than the allowable time (L6-03).

## 5.2 Fault Detection

There is a fault on the machine side.		Check the load for any problems.
UL4	UL4	Undertorque Detection 2
		The current has fallen below the minimum value set for torque detection (L6-05) for longer than the allowable time (L6-06).
UL5	UL5	Mechanical Weakening Detection 2
		The operation conditions matched the conditions set to L6-08.
Uv1	Uv1	DC Bus Undervoltage
		One of the following conditions occurred while the drive was in operation: <ul style="list-style-type: none"> <li>• Voltage in the DC bus fell below the undervoltage detection level (L2-05).</li> <li>• For 200 V class: approximately 190 V (160 V for single phase drives)</li> <li>• For 400 V class: approximately 380 V (350 V when E1-01 is less than 400)</li> </ul> The fault is output only if L2-01 = 0 or L2-01 = 1 and the DC bus voltage is under L2-05 for longer than L2-02.
<b>Cause</b>		<b>Possible Solution</b>
Input power phase loss.		<ul style="list-style-type: none"> <li>• The main circuit drive input power is wired incorrectly.</li> <li>• Correct the wiring.</li> </ul>
One of the drive input power wiring terminals is loose.		<ul style="list-style-type: none"> <li>• Ensure there are no loose terminals.</li> <li>• Apply the tightening torque specified in this manual to fasten the terminals.</li> </ul>
There is a problem with the voltage from the drive input power.		<ul style="list-style-type: none"> <li>• Check the voltage.</li> <li>• Correct the voltage to within range listed in drive input power specifications.</li> </ul>
The power has been interrupted.		Correct the drive input power.
Drive internal circuitry has become worn.		<ul style="list-style-type: none"> <li>• Check the maintenance time for the capacitors (U4-05).</li> <li>• Replace the drive if U4-05 exceeds 90%.</li> </ul>
The drive input power transformer is not large enough and voltage drops after switching on power.		Check the capacity of the drive input power transformer.
Air inside the drive is too hot.		Check the drive internal temperature.
Problem with the CHARGE indicator.		Replace the drive.
Uv2	Uv2	Control Power Supply Voltage Fault
		Voltage is too low for the control drive input power.
<b>Cause</b>		<b>Possible Solution</b>
L2-02 changed from its default value in drive that is 7.5 kW or smaller without installing a Momentary Power Loss Ride-Thru.		Correct parameter L2-02 setting or install optional Momentary Power Loss Ride-Thru unit.
The wiring for the control power supply is damaged.		<ul style="list-style-type: none"> <li>• Cycle power to the drive. Check if the fault reoccurs.</li> <li>• Replace the drive if the fault continues to occur.</li> </ul>

Internal circuitry is damaged.		<ul style="list-style-type: none"> <li>• Cycle power to the drive. Check if the fault reoccurs.</li> <li>• Replace the drive if the fault continues to occur.</li> </ul>
<i>Uv3</i>	Uv3	Undervoltage 3 (Inrush Prevention Circuit Fault)
		The inrush prevention circuit has failed.
<b>Cause</b>		<b>Possible Solution</b>
The contactor on the inrush prevention circuit is damaged.		<ul style="list-style-type: none"> <li>• Cycle power to the drive. Check if the fault reoccurs.</li> <li>• Replace the drive if the fault continues to occur.</li> <li>• Check monitor U4-06 for the performance life of the inrush prevention circuit.</li> <li>• Replace the drive if U4-06 exceeds 90%.</li> </ul>

## 5.3 Alarm Detection

### ◆ Alarm Codes, Causes, and Possible Solutions

Table 5.3 Alarm Codes, Causes, and Possible Solutions

LED Operator Display		Minor Fault Name
<i>AEr</i>	AEr	Communication Option Station Number Setting
		Option node address is outside the acceptable setting range.
<i>bb</i>	bb	Baseblock
		Drive output interrupted as indicated by an external baseblock signal.
<i>bUS</i>	bUS	Option Communication Error
		<ul style="list-style-type: none"> <li>After initial communication was established, the connection was lost.</li> <li>Assign a run command frequency reference to the option card.</li> </ul>
<i>CALL</i>	CALL	Serial Communication Transmission Error
		Communication has not yet been established.
<i>CE</i>	CE	MEMOBUS/Modbus Communication Error
		Control data was not received correctly for two seconds.
<i>CrST</i>	CrST	Can Not Reset
<i>dEv</i>	dEv	Speed Deviation (for Simple V/f with PG)
		According to the pulse input (RP), the speed deviation is greater than the setting in F1-10 for a time longer than the setting in F1-11.
<i>dnE</i>	dnE	Drive Disabled
<i>EF</i>	EF	Forward/Reverse Run Command Input Error
		Both forward run and reverse run closed simultaneously for over 0.5 s.
<i>EF0</i>	EF0	Option Card External Fault
		An external fault condition is present.
<i>EF1</i>	EF1	External fault (input terminal S1)
		External fault at multi-function input terminal S1.
<i>EF2</i>	EF2	External fault (input terminal S2)
		External fault at multi-function input terminal S2.
<i>EF3</i>	EF3	External fault (input terminal S3)
		External fault at multi-function input terminal S3.
<i>EF4</i>	EF4	External fault (input terminal S4)
		External fault at multi-function input terminal S4.

<i>EF5</i>	EF5	External fault (input terminal S5)
		External fault at multi-function input terminal S5.
<i>EF6</i>	EF6	External fault (input terminal S6)
		External fault at multi-function input terminal S6.
<i>EF7</i>	EF7	External fault (input terminal S7)
		External fault at multi-function input terminal S7.
<i>FbH</i>	FbH	Excessive PID Feedback
		The PID feedback input is higher than the level set in b5-36 for longer than the time set in b5-37, and b5-12 is set to 1 or 4.
<i>FbL</i>	FbL	PID Feedback Loss
		The PID feedback input is lower than the level set in b5-13 for longer than the time set in b5-14, and b5-12 is set to 1 or 4.
<i>Hbb</i>	Hbb	Safe Disable Signal Input
		Both Safe Disable Input channels are open.
<i>HbbF</i>	HbbF	Safe Disable Signal Input
		One of the Safe Disable input channels is open.
<i>HCA</i>	HCA	Current Alarm
		Drive current exceeded overcurrent warning level (150% of the rated current).
<i>LT-1</i>	LT-1	Cooling Fan Maintenance Time
		The cooling fan has reached its expected maintenance period and may need to be replaced. <b>Note:</b> An alarm output (H2-□□ = 10) will only be triggered if H2-□□ = 2F.
<i>LT-2</i>	LT-2	Capacitor Maintenance Time
		The main circuit and control circuit capacitors are nearing the end of their expected performance life. <b>Note:</b> An alarm output (H2-□□ = 10) will only be triggered if H2-□□ = 2F.
<i>LT-3</i>	LT-3	Soft Charge Bypass Relay Maintenance Time
		The DC bus soft charge relay is nearing the end of its expected performance life. <b>Note:</b> An alarm output (H2-□□ = 10) will only be triggered if H2-□□ = 2F.
<i>LT-4</i>	LT-4	IGBT Maintenance Time (50%)
		IGBTs have reached 50% of their expected performance life. <b>Note:</b> An alarm output (H2-□□ = 10) will only be triggered if H2-□□ = 2F.
<i>oH</i>	oH	Heatsink Overheat
		The temperature exceeded the value set to L8-02.
<i>oH2</i>	oH2	Drive Overheat Warning
		“Drive Overheat Warning” was input to a multi-function input terminal, S1 through S7 (H1-□□= B)

### 5.3 Alarm Detection

<i>oH3</i>	oH3	Motor Overheat
		The motor overheat signal entered to a multi-function analog input terminal exceeded the alarm level (H3-02 or H3-10 = E).
<i>oL3</i>	oL3	Overtorque 1
		Drive output current (or torque in OLV) was greater than L6-02 for longer than the time set in L6-03.
<i>oL4</i>	oL4	Overtorque 2
		Drive output current (or torque in OLV) was greater than L6-05 for longer than the time set in L6-06.
<i>oL5</i>	oL5	Mechanical Weakening Detection 1
		Overtorque occurred, matching the conditions specified in L6-08.
<i>oS</i>	oS	Overspeed (for Simple V/f with PG)
		Pulse input (RP) indicates that motor speed feedback exceeded F1-08 setting.
<i>ou</i>	ov	DC Bus Overvoltage
		The DC bus voltage exceeded the trip point. For 200 V class: approximately 410 V For 400 V class: approximately 820 V (740 V when E1-01 < 400)
<i>PASS</i>	PASS	MEMOBUS/Modbus Comm. Test Mode Complete
<i>PGo</i>	PGo	PG Disconnect (for Simple V/f with PG)
		Detected when no PG pulses received for a time longer than setting in F1-14.
<i>rUn</i>	rUn	Motor Switch during Run
		A command to switch motors was entered during run.
<i>SE</i>	SE	MEMOBUS/Modbus Communication Test Mode Error <b>Note:</b> This alarm will not trigger a multi-function output terminal that is set for alarm output (H2-□□ = 10).
<i>TrPC</i>	TrPC	IGBT Maintenance Time (90%)
		IGBTs have reached 90% of their expected performance life.
<i>UL3</i>	UL3	Undertorque Detection 1
		Drive output current (or torque in OLV) less than L6-02 for longer than L6-03 time.
<i>UL4</i>	UL4	Undertorque Detection 2
		Drive output current (or torque in OLV) less than L6-05 for longer than L6-06 time.
<i>Uv</i>	Uv	Undervoltage
		One of the following conditions was true when the drive was stopped and a run command was entered: <ul style="list-style-type: none"> <li>DC bus voltage dropped below the level specified in L2-05.</li> <li>Contactors to suppress inrush current in the drive was open.</li> <li>Low voltage in the control drive input power. This alarm outputs only if L2-01 is not 0 and DC bus voltage is under L2-05.</li> </ul>

## 5.4 Operator Programming Errors

An Operator Programming Error (oPE) occurs when an inappropriate parameter is set or an individual parameter setting is inappropriate.

### ◆ oPE Codes, Causes, and Possible Solutions

Table 5.4 oPE Codes, Causes, and Possible Solutions

LED Operator Display		Error Name
<i>oPE01</i>	oPE01	Drive Capacity Setting Fault
		Drive capacity and the value set to o2-04 do not match.
<i>oPE02</i>	oPE02	Parameter Range Setting Error
		Use U1-18 to find parameters set outside the range.
<i>oPE03</i>	oPE03	Multi-Function Input Selection Error
		A contradictory setting is assigned to multi-function contact inputs H1-01 to H1-07.
<i>oPE04</i>	oPE04	Initialization required.
<i>oPE05</i>	oPE05	Run Command/Frequency Reference Source Selection Error
<i>oPE07</i>	oPE07	Multi-Function Analog Input Selection Error
		A contradictory setting is assigned to multi-function analog inputs H3-02 through to H3-10 and PID functions conflict.
<i>oPE08</i>	oPE08	Parameter Selection Error
		A function has been set that cannot be used in the motor control method selected.
<i>oPE09</i>	oPE09	PID Control Selection Fault
		PID control function selection is incorrect. Requires that PID control is enabled (b5-01 = 1 to 4).
<i>oPE10</i>	oPE10	V/f Data Setting Error
		The following setting errors have occurred where: E1-04 is greater than or equal to E1-06 is greater than or equal to E1-07 is greater than or equal to E1-09. Or the following setting errors have occurred: E3-04 is greater than or equal to E3-06 is greater than or equal to E3-07 is greater than or equal to E3-09.
<i>oPE11</i>	oPE11	Carrier Frequency Setting Error
		Correct the setting for the carrier frequency.
<i>oPE13</i>	oPE13	Pulse Monitor Selection Error
		Incorrect setting of monitor selection for Pulse Train (H6-06).

# 5.5 Auto-Tuning Fault Detection

Auto-Tuning faults are shown below. When the following faults are detected, the fault is displayed on the Digital Operator and the motor coasts to a stop. No fault or alarm outputs will occur

## ◆ Auto-Tuning Codes, Causes, and Possible Solutions

**Table 5.5 Auto-Tuning Codes, Causes, and Possible Solutions**

LED Operator Display		Error Name
$\text{E}nd1$	End1	Excessive V/f Setting. Displayed after Auto-Tuning is complete.
<b>Cause</b>		<b>Possible Solutions</b>
The torque reference exceeded 20% during Auto-Tuning.		<ul style="list-style-type: none"> <li>• Before Auto-Tuning the drive, verify the information written on the motor nameplate and enter that data to T1-03 through T1-05.</li> <li>• Enter proper information to parameters T1-03 to T1-05 and repeat Auto-Tuning.</li> <li>• If possible, disconnect the motor from the load and perform Auto-Tuning.</li> </ul>
The no-load current exceeded 80% of the drive rated current during Auto-Tuning.		
$\text{E}nd2$	End2	Motor Iron-Core Saturation Coefficient. Detected only during Rotational Auto-Tuning and displayed after Auto-Tuning is complete.
<b>Cause</b>		<b>Possible Solutions</b>
Motor data entered during Auto-Tuning was incorrect.		<ul style="list-style-type: none"> <li>• Motor data entered to the T1 parameters does not match the information written on the motor nameplate.</li> <li>• Restart Auto-Tuning and enter the correct information.</li> </ul>
Auto-Tuning calculated values outside the parameter setting range, assigning the iron-core saturation coefficient (E2-07, -08) a temporary value.		<ul style="list-style-type: none"> <li>• Check and correct faulty motor wiring.</li> <li>• Disconnect the motor from machine and perform Rotational Auto-Tuning.</li> </ul>
$\text{E}nd3$	End3	Rated Current Setting Alarm (displayed after Auto-Tuning is complete)
<b>Cause</b>		<b>Possible Solutions</b>
<ul style="list-style-type: none"> <li>• The motor line-to-line resistance and the motor-rated current are not consistent with one another.</li> <li>• The correct current rating printed on the nameplate was not entered into T1-04.</li> </ul>		<ul style="list-style-type: none"> <li>• Check the setting of parameter T1-04.</li> <li>• Check the motor data and repeat Auto-Tuning.</li> </ul>
$\text{E}r-01$	Er-01	Motor Data Error
<b>Cause</b>		<b>Possible Solutions</b>
Motor data or data entered during Auto-Tuning was incorrect.		<ul style="list-style-type: none"> <li>• Check that the motor data entered to T1 parameters matches motor nameplate input before Auto-Tuning.</li> <li>• Start Auto-Tuning over again and enter the correct information.</li> </ul>

## 5.5 Auto-Tuning Fault Detection

Motor output and motor-rated current settings (T1-02 and T1-04) do not match.	<ul style="list-style-type: none"> <li>• Check the drive and motor capacities.</li> <li>• Correct the settings of parameters T1-02 and T1-04.</li> </ul>
Motor output and no-load current settings (T1-04 and E2-03) do not match. Data required when Auto-Tuning for OLV Control or Stationary Auto-Tuning.	<ul style="list-style-type: none"> <li>• Check the motor-rated current and no-load current.</li> <li>• Correct the settings of parameters T1-04 and E2-03.</li> </ul>
Base frequency and base motor rotations (T1-05 and T1-07) do not match.	Set T1-05 and T1-07 to the correct value.
$E r - 02$	Er-02
Minor Fault	
<b>Cause</b>	<b>Possible Solutions</b>
Incorrect motor data entered during Auto-Tuning.	<ul style="list-style-type: none"> <li>• Motor data entered to the T1 parameters does not match the information written on the motor nameplate. Enter the correct data.</li> <li>• Start Auto-Tuning over again and enter the correct information.</li> </ul>
The wiring is faulty.	<ul style="list-style-type: none"> <li>• Check the wiring and correct defective connections.</li> </ul>
Load is too heavy.	<ul style="list-style-type: none"> <li>• Check around the machine.</li> <li>• Check the load.</li> </ul>
$E r - 03$	Er-03
STOP Button Input	
<b>Cause</b>	<b>Possible Solutions</b>
Auto-Tuning canceled by pressing STOP button.	Auto-Tuning did not complete properly and will have to be performed again.
$E r - 04$	Er-04
Line-to-Line Resistance Error	
<b>Cause</b>	<b>Possible Solutions</b>
Motor data entered during Auto-Tuning was incorrect.	<ul style="list-style-type: none"> <li>• Motor data entered to T1 parameters does not match motor nameplate. Enter the correct data.</li> <li>• Start Auto-Tuning over again and enter the correct information.</li> </ul>
Auto-Tuning did not complete within designated time frame.	<ul style="list-style-type: none"> <li>• Check and correct faulty motor wiring.</li> </ul>
Drive-calculated values outside parameter setting range.	<ul style="list-style-type: none"> <li>• Disconnect the motor from machine and perform Rotational Auto-Tuning.</li> </ul>
$E r - 05$	Er-05
No-Load Current Error	
<b>Cause</b>	<b>Possible Solutions</b>
Motor data entered during Auto-Tuning was incorrect.	<ul style="list-style-type: none"> <li>• Motor data entered to T1 parameters does not match motor nameplate. Enter the correct data.</li> <li>• Restart Auto-Tuning and enter the correct information.</li> </ul>
Auto-Tuning did not complete within designated time frame.	<ul style="list-style-type: none"> <li>• Check and correct faulty motor wiring.</li> </ul>
Drive-calculated values outside parameter setting range.	<ul style="list-style-type: none"> <li>• Disconnect the motor from machine and perform Rotational Auto-Tuning.</li> </ul>

## 5.5 Auto-Tuning Fault Detection

$E_r - 08$	Er-08	Rated Slip Error
<b>Cause</b>		<b>Possible Solutions</b>
Motor data entered during Auto-Tuning was incorrect.		<ul style="list-style-type: none"> <li>Motor data entered to T1 parameters does not match motor nameplate. Enter the correct data.</li> <li>Restart Auto-Tuning and enter the correct information.</li> </ul>
Auto-Tuning did not complete within designated time frame.		<ul style="list-style-type: none"> <li>Check and correct faulty motor wiring.</li> </ul>
Values calculated by the drive are outside the allowable parameter setting ranges.		<ul style="list-style-type: none"> <li>Disconnect the motor from machine and perform Auto-Tuning.</li> </ul>
$E_r - 09$	Er-09	Acceleration Error (detected only during Rotational Auto-Tuning)
<b>Cause</b>		<b>Possible Solutions</b>
The motor did not accelerate for the specified acceleration time.		<ul style="list-style-type: none"> <li>Increase the acceleration time (C1-01).</li> <li>Check if it is possible to disconnect the machine from the motor.</li> </ul>
Torque limit when motoring is too low (L7-01 and L7-02).		<ul style="list-style-type: none"> <li>Check the settings of parameters L7-01 and L7-02.</li> <li>Increase the setting.</li> </ul>
$E_r - 11$	Er-11	Motor Speed Fault (detected only when Auto-Tuning is enabled)
<b>Cause</b>		<b>Possible Solutions</b>
Torque reference is too high. (Enabled in OLV only.)		<ul style="list-style-type: none"> <li>Increase the acceleration time (C1-01).</li> <li>Disconnect the machine from the motor, if possible.</li> </ul>
$E_r - 12$	Er-12	Current Detection Error
<b>Cause</b>		<b>Possible Solutions</b>
One of the motor phases is missing (U/T1, V/T2, W/T3).		Check motor wiring and correct problems.
Current exceeded the current rating of the drive.		<ul style="list-style-type: none"> <li>Check the motor wiring for a short between motor lines.</li> <li>If a magnetic contactor is used between motors, ensure it is on.</li> </ul>
The current is too low.		<ul style="list-style-type: none"> <li>Replace the drive.</li> </ul>
Attempted Auto-Tuning without motor connected to the drive.		Connect the motor and perform Auto-Tuning.
Current detection signal error.		Replace the drive.

## 5.6 Diagnosing and Resetting Faults

### ◆ Fault Reset Methods

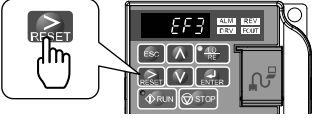
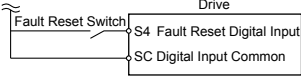
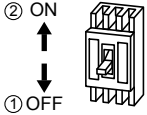
After the Fault Occurs	Procedure	
Fix the cause of the fault, restart the drive, and reset the fault	Press  on the digital operator.	
Fix the cause of the fault and reset via Fault Reset Digital Input S4.	Close then open the fault signal digital input via terminal S4. S4 is set fault reset as default (HI-04 = 12)	
If the above methods do not reset the fault, turn off the drive main power supply. Reapply power after LED operator display is out.		

**This Page Intentionally Blank**



[efesotomasyon.com](http://efesotomasyon.com)

## Specifications

<b>6.1</b>	<b>HEAVY DUTY AND NORMAL DUTY RATINGS</b>	
	.....	<b>150</b>
<b>6.2</b>	<b>SINGLE/THREE-PHASE 200 V CLASS DRIVE</b>	
	.....	<b>151</b>
<b>6.3</b>	<b>THREE-PHASE 400 V CLASS DRIVES.....</b>	<b>155</b>

# 6.1 Heavy Duty and Normal Duty Ratings

The capacity of the drive is based on two types of load characteristics: Heavy Duty (HD) and Normal Duty (ND).

*Refer to [Selecting the Appropriate Load Rating on page 150](#) for the differences between HD and ND. Specifications for capacity ratings are listed on the following pages.*

**Table 6.1 Selecting the Appropriate Load Rating**

Setting Parameter C6-01	Rated Output Current	Overload Tolerance	Default Carrier Frequency
0: Heavy Duty	HD Rating varies by model <1>	150% rated output current for 60 s	8/10 kHz varies by model
1: Normal Duty (default)	ND Rating varies by model <1>	120% rated output current for 60 s varies by model	2 kHz, Swing PWM

<1> The following pages list information on rating changes based on drive model.



- **HD and ND:** HD refers to applications requiring constant torque output, while ND refers to applications with variable torque needs. The drive allows the user to select HD or ND torque depending on the application. Fans, pumps, and blowers should use ND (C6-01 = “1”), and other applications generally use HD (C6-01 = “0”).
- **Swing PWM:** Swing PWM equivalent to a 2 kHz audible noise. This function turns the motor noise into a less obtrusive white noise.

**Note:** Differences between HD ratings and ND ratings for the drive include rated input and output current, overload capacity, carrier frequency, and current limit. The default setting is for ND (C6-01 = 1).

## 6.2 Single/Three-Phase 200 V Class Drive

Table 6.2 Power Ratings

Item			Specification							
Three-Phase: CIMR-V□2A			0001	0002	0004	0006	0010	0012	0020	
Single-Phase: CIMR-V□BA <2>			0001	0002	0003	0006	0010	0012	0018 <2>	
Maximum Motor Size Allowed (HP) <2>		ND Rating	0.13	0.25	0.5/ 0.75	1.0/ 1.5	2.0/ 3.0	3.0	5.5 <2>	
		HD Rating	0.13	0.25	0.5/ 0.75	0.75/ 1.0	1.5/ 2.0	3.0	5.0	
Input	Input Current (A) <2>	Three-phase	ND Rating	1.1	1.9	3.9	7.3	10.8	13.9	24.0
		HD Rating	0.7	1.5	2.9	5.8	7.5	11.0	18.9	
	Single-phase	ND Rating	2.0	3.6	7.3	13.8	20.2	24.0	–	
		HD Rating	1.4	2.8	5.5	11.0	14.1	20.6	35.0	
Rated Output Capacity (kVA) <2>		ND Rating	0.5	0.7	1.3	2.3	3.7	4.6	7.5	
		HD Rating	0.3	0.6	1.1	1.9	3.0	4.2	6.7	
Output Current (A)		ND Rating <2>	1.2	1.9	3.5 (3.3)	6.0	9.6	12.0	19.6	
		HD Rating	0.8 <2>	1.6 <2>	3.0 <2>	5.0 <2>	8.0 <2>	11.0 <2>	17.5 <2>	
Output		Overload Tolerance	ND Rating: 120% of rated output current for 1 minute HD Rating: 150% of rated output current for 1 minute (Derating may be required for applications that start and stop frequently)							
		Carrier Frequency	2 kHz (user-set, 2 to 15 kHz)							
		Max Output Voltage (V)	Three-phase power: Three-phase 200 to 240 V Single-phase power: Three-phase 200 to 240 V (both proportional to input voltage)							
		Max Output Frequency (Hz)	400 Hz (user-adjustable)							
		Rated Voltage Rated Frequency	Three-phase power: Three-phase 200 to 240 V 50/60 Hz Single-phase power: 200 to 240 V 50/60 Hz							
Power Supply		Allowable Voltage Fluctuation	-15 to 10%							
		Allowable Frequency Fluctuation	±5%							
Harmonic Corrective Actions		DC Reactor	Optional							

- <1> Drives with single-phase power supply input will output three-phase power and cannot run a single-phase motor.
- <2> CIMR-V□BA0020 only. CIMR-V□BA0018 is available with a Heavy Duty rating only.
- <3> The motor capacity (HP) refers to a NEC rated 4-pole motor. The rated output current of the drive output amps should be equal to or greater than the motor rated current.
- <4> Input current rating varies depending on the power supply transformer, input reactor, wiring connections, and power supply impedance.

## 6.2 Single/Three-Phase 200 V Class Drive

---

- <5> Rated motor capacity is calculated with a rated output voltage of 230 V.
- <6> Carrier frequency is set to 2 kHz (Swing PWM). Current derating is required in order to raise the carrier frequency.
- <7> Carrier frequency is set to 10 kHz. Current derating is required in order to raise the carrier frequency.
- <8> Carrier frequency is set to 8 kHz. Current derating is required in order to raise the carrier frequency.

## 6.2 Single/Three-Phase 200 V Class Drive

Table 6.3 Power Ratings Continued

Item			Specification				
Three-Phase: CIMR-V□2A			0030	0040	0056	0069	
Single-Phase: CIMR-V□BA <1>			-	-	-	-	
Maximum Motor Size Allowed (HP) <2>		ND Rating	10.0	15.0	20.0	25.0	
		HD Rating	7.5	10.0	15.0	20.0	
Input	Input Current (A) <3>	Three-Phase	ND Rating	34.7	50.9	69.4	85.6
			HD Rating	26.0	35.4	51.9	70.8
		Single-Phase	ND Rating	-	-	-	-
			HD Rating	-	-	-	-
Output	Rated Output Capacity (kVA) <4>		ND Rating	11.4	15.2	21.3	26.3
			HD Rating	9.5	12.6	17.9	22.9
	Output Current (A)		ND Rating <5>	30.0	40.0	56.0	69.0
			HD Rating	25.0 <6>	33.0 <6>	47.0 <6>	60.0 <6>
	Overload Tolerance			ND Rating: 120% of rated output current for 1 minute HD Rating: 150% of rated output current for 1 minute (Derating may be required for applications that start and stop frequently)			
	Carrier Frequency			2 kHz (user-set, 2 to 15 kHz)			
	Max Output Voltage (V)			Three-phase power: Three-phase 200 to 240 V Single-phase power: Three-phase 200 to 240 V (both proportional to input voltage)			
	Max Output Frequency (Hz)			400 Hz (user-adjustable)			
	Power Supply	Rated Voltage Rated Frequency		Three-phase power: Three-phase 200 to 240 V 50/60 Hz Single-phase power: 200 to 240 V 50/60 Hz			
		Allowable Voltage Fluctuation		-15 to 10%			
Allowable Frequency Fluctuation		±5%					
Harmonic Corrective Actions		DC Reactor	Optional				

- <1> Drives with single-phase power supply input will output three-phase power and cannot run a single-phase motor.
- <2> The motor capacity (HP) refers to a NEC rated 4-pole motor. The rated output current of the drive output amps should be equal to or greater than the motor rated current.
- <3> Input current rating varies depending on the power supply transformer, input reactor, wiring connections, and power supply impedance.
- <4> Rated motor capacity is calculated with a rated output voltage of 220 V.
- <5> Carrier frequency is set to 2 kHz (Swing PWM). Current derating is required in order to raise the carrier frequency.

## 6.2 Single/Three-Phase 200 V Class Drive

---

<8> Carrier frequency is set to 8 kHz. Current derating is required in order to raise the carrier frequency.

**Note:** Differences between Heavy Duty (HD) ratings and Normal Duty (ND) ratings for the drive include rated input and output current, overload capacity, carrier frequency and current limit. Set parameter C6-01 to “0” for HD or “1” for ND (default).

## 6.3 Three-Phase 400 V Class Drives

Table 6.4 Power Ratings

Item			Specification						
CIMR-V□4A			0001	0002	0004	0005	0007	0009	0011
Maximum Applicable Motor Capacity (HP) <1>		ND Rating	0.25	0.5/ 0.75/ 1.0	1.5/2.0	3.0	3.0	5.0	7.5
		HD Rating	0.25	0.5/ 0.75	1.0/ 1.5 /2.0	3.0	3.0	5.0	5.0
Input	Input Current (A) <2>	ND Rating	1.2	2.1	4.3	5.9	8.1	9.4	14.0
		HD Rating	1.2	1.8	3.2	4.4	6.0	8.2	10.4
Output	Output Current (kVA) <3>	ND Rating <4>	0.9	1.6	3.1	4.1	5.3	6.7	8.5
		HD Rating <4>	0.9	1.4	2.6	3.7	4.2	5.5	7.0
	Output Current (A) <4>	ND Rating <4>	1.2	2.1	4.1	5.4	6.9	8.8	11.1
		HD Rating <4>	1.2	1.8	3.4	4.8	5.5	7.2	9.2
	Overload Tolerance		ND Rating: 120% of rated output current for 60 s HD Rating: 150% of rated output current for 60 s (Derating may be required for applications that start and stop frequently)						
	Carrier Frequency		User adjustable between 2 and 15 kHz (see HD output current line of this table for default values)						
	Maximum Output Voltage (V)		Three-phase: 380 to 480 V (proportional to input voltage)						
	Maximum Output Frequency (Hz)		400 Hz (user-adjustable)						
Rated Voltage Rated Frequency		Three-phase: 380 to 480 V 50/60 Hz							
Power Supply	Allowable Voltage Fluctuation		-15 to 10%						
	Allowable Frequency Fluctuation		±5%						
Harmonic Corrective Actions		DC Reactor		Optional					

- <1> The motor capacity (HP) refers to a NEC 4-pole motor. The rated output current of the drive output amps should be equal to or greater than the motor rated current.
- <2> Input current rating varies depending on the power supply transformer, input reactor, wiring conditions, and power supply impedance.
- <3> Rated motor capacity is calculated with a rated output voltage of 460 V.
- <4> Carrier frequency is set to 2 kHz (Swing PWM). Current derating is required in order to raise the carrier frequency.
- <5> Carrier frequency is set to 8 kHz. Current derating is required in order to raise the carrier frequency.

## 6.3 Three-Phase 400 V Class Drives

Table 6.5 Power Ratings Continued

Item		Specification				
CIMR-V□4A		0018	0023	0031	0038	
Maximum Applicable Motor Capacity (HP) <1>		ND Rating	10.0	15.0	20.0	25.0
		HD Rating	7.5	10.0	15.0	20.0
Input	Input Current (A) <2>	ND Rating	20.0	24.0	38.0	44.0
		HD Rating	15.0	20.0	29.0	39.0
Output	Output Current (kVA) <3>	ND Rating <4>	13.3	17.5	23.6	29.0
		HD Rating <4>	11.3	13.7	18.3	23.6
	Output Current (A)	ND Rating <4>	17.5	23.0	31.0	38.0
		HD Rating <4>	14.8	18.0	24.0	31.0
	Overload Tolerance		ND Rating: 120% of rated output current for 60 s HD Rating: 150% of rated output current for 60 s (Derating may be required for applications that start and stop frequently)			
	Carrier Frequency		2 kHz (user-adjustable from 2 to 15 kHz)			
	Maximum Output Voltage (V)		Three-phase: 380 to 480 V (proportional to input voltage)			
	Maximum Output Frequency (Hz)		400 Hz (user-adjustable)			
Power Supply	Rated Voltage Rated Frequency		Three-phase: 380 to 480 V 50/60 Hz			
	Allowable Voltage Fluctuation		-15 to 10%			
	Allowable Frequency Fluctuation		±5%			
Harmonic Corrective Actions		DC Reactor		Optional		

- <1> The motor capacity (HP) refers to a NEC 4-pole motor. The rated output current of the drive output amps should be equal to or greater than the motor rated current.
- <2> Input current rating varies depending on the power supply transformer, input reactor, wiring conditions, and power supply impedance.
- <3> Rated motor capacity is calculated with a rated output voltage of 440 V.
- <4> Carrier frequency is set to 2 kHz (Swing PWM). Current derating is required in order to raise the carrier frequency.
- <5> Carrier frequency is set to 8 kHz. Current derating is required in order to raise the carrier frequency.

**Note:** Differences between Heavy Duty (HD) ratings and Normal Duty (ND) ratings for the drive include rated input and output current, overload capacity, carrier frequency and current limit. Set parameter C6-01 to “0” for HD or “1” for ND (default).



## Parameter List

---

This chapter contains a full listing of all parameters and settings available in the drive

<b>7.1</b>	<b>PARAMETER TABLE.....</b>	<b>158</b>
------------	-----------------------------	------------

## 7.1 Parameter Table

No.	Name	Description
<b>A1: Initialization Parameters</b>		
Use A1 parameters to configure the basic environment for drive operation.		
A1-01	Access Level Selection	0: Operation only 1: User Parameters (access to parameters selected by the user) 2: Advanced Access Level
A1-02	Control Method Selection	0: V/f Control without PG 2: Open Loop Vector (OLV) 5: PM Open Loop Vector (PM)  <b>Note:</b> 1. Does not return to the default setting after initialization. 2. If using Open Loop Vector Control (A1-02 = 2), then Auto-Tuning must be performed again after initialization. <i>Refer to Auto-Tuning on page 109.</i>
A1-03	Initialize Parameters	0: No Initialize 1110: User Initialize (First set user parameter values must be stored using parameter o2-03) 2220: 2-Wire Initialization 3330: 3-Wire Initialization 5550: OPE04 Error Reset
A1-04	Password 1	Refer to V1000 Technical Manual for details.
A1-05	Password 2	Refer to V1000 Technical Manual for details.
A1-06	Application Preset	Refer to V1000 Technical Manual for details.
A1-07	DriveWorksEZ Function Selection	Refer to V1000 Technical Manual for details.
<b>A2: User Parameters</b>		
Use A2 parameters to program the drive.		
A2-01 to A2-32	User Parameters, 1 to 32	Refer to V1000 Technical Manual for details.
A2-33	User Parameter Automatic Selection	Refer to V1000 Technical Manual for details.
<b>b1: Operation Mode Selection</b>		
Use b1 parameters to configure the operation mode.		
b1-01	Frequency Reference Selection 1	0: Operator - Digital preset speed d1-01 to d1-17. 1: Terminals - Analog input terminal A1 or A2. 2: Memobus communications 3: Option PCB 4: Pulse Input (Terminal RP)
b1-02	Run Command Selection 1	0: Operator - RUN and STOP keys on the digital operator. 1: Digital input terminals S1 to S7 2: Memobus communications 3: Option PCB.

No.	Name	Description
b1-03	Stopping Method Selection	0: Ramp to Stop 1: Coast to Stop 2: DC Injection Braking to Stop 3: Coast with Timer (A new run command is ignored if received before the timer expires)
b1-04	Reverse Operation Selection	0: Reverse enabled. 1: Reverse disabled.
b1-07	Local/Remote Run Selection	Refer to V1000 Technical Manual for details.
b1-08	Run Command Selection while in Programming Mode	0: Run command accepted only in the operation menu. 1: Run command accepted in all menus. 2: Prohibit entering programming mode during Run
b1-14	Phase Order Selection	Sets phase order for drive output terminals U/T1, V/T2 and W/T3. 0: Standard 1: Switch phase order
b1-15	Frequency Reference 2	Refer to V1000 Technical Manual for details.
b1-16	Run Command Source 2	Refer to V1000 Technical Manual for details.
b1-17	Run Command at Power Up	Refer to V1000 Technical Manual for details.
<b>b2: DC Injection Braking</b> Use b2 parameters to configure DC Injection Braking operation		
b2-01	DC Injection Braking Start Frequency	Refer to V1000 Technical Manual for details.
b2-02	DC Injection Braking Current	Sets the DC Injection Braking current as a percentage of the drive rated current.
b2-03	DC Injection Braking Time/DC Excitation Time at Start	Sets DC Injection Braking time at start. Disabled when set to 0.00 seconds.
b2-04	DC Injection Braking Time at Stop	Sets DC Injection Braking time at stop.
b2-08	Magnetic Flux Compensation Value	Refer to V1000 Technical Manual for details.
b2-12	Short Circuit Brake Time at Start	Refer to V1000 Technical Manual for details.
b2-13	Short Circuit Brake Time at Stop	Refer to V1000 Technical Manual for details.
<b>b3: Speed Search</b> Use B3 parameters to configure Speed Search function operation.		
b3-01	Speed Search Selection	Refer to V1000 Technical Manual for details.
b3-02	Speed Search Deactivation Current	Sets the current level at which the speed is assumed to be detected and Speed Search is ended. Set in percent of the drive rated current.
b3-03	Speed Search Deceleration Time	Sets time constant used to reduce the output frequency during speed search. Related to a change from max. output frequency to 0.
b3-05	Speed Search Delay Time	Refer to V1000 Technical Manual for details.
b3-06	Output Current 1 during Speed Search	Refer to V1000 Technical Manual for details.
b3-10	Speed Search Detection Compensation Gain	Refer to V1000 Technical Manual for details.

## 7.1 Parameter Table

No.	Name	Description
b3-14	Bi-Directional Speed Search Selection	Refer to V1000 Technical Manual for details.
b3-17	Speed Search Restart Current Level	Refer to V1000 Technical Manual for details.
b3-18	Speed Search Restart Detection Time	Refer to V1000 Technical Manual for details.
b3-19	Number of Speed Search Restarts	Refer to V1000 Technical Manual for details.
b3-24	Speed Search Method Selection	Refer to V1000 Technical Manual for details.
b3-25	Speed Search Retry Interval Time	Refer to V1000 Technical Manual for details.
<b>b4: Timer Function</b>		
Use b4 parameters to configure timer function operation.		
b4-01	Timer Function On-Delay Time	Refer to V1000 Technical Manual for details.
b4-02	Timer Function Off-Delay Time	Refer to V1000 Technical Manual for details.
<b>b5: PID Control</b>		
Use b5 parameters to configure the PID control drive function.		
b5-01	PID Function Setting	0: Disabled 1: Enable (Deviation is D-controlled) 2: Enable (Feedback is D-controlled) 3: Enable (Deviation is D-controlled, PID output added to Freq. Ref.) 4: Enable (Feedback is D-controlled, PID output added to Freq. Ref.)
b5-02	Proportional Gain Setting (P)	Sets the proportional gain of the PID controller. A setting of 0.00 disables P control.
b5-03	Integral Time Setting (I)	Sets the integral time for the PID controller. A setting of 0.0 s disables integral control.
b5-04	Integral Limit Setting	Sets the maximum output possible from the integrator.
b5-05	Derivative Time (D)	Sets D control derivative time. A setting of 0.00 s disables derivative control.
b5-06	PID Output Limit	Refer to V1000 Technical Manual for details.
b5-07	PID Offset Adjustment	Applies an offset to the PID controller output.
b5-08	PID Primary Delay Time Constant	Sets the amount of time for the filter on the output of the PID controller.
b5-09	PID Output Level Selection	Refer to V1000 Technical Manual for details.
b5-10	PID Output Gain Setting	Sets the gain applied to the PID output.
b5-11	PID Output Reverse Selection	Refer to V1000 Technical Manual for details.

## 7.1 Parameter Table

No.	Name	Description
b5-12	PID Feedback Reference Missing Detection Selection	0: Disabled. 1: Feedback loss detected when PID enabled. Alarm output, operation is continued without triggering a fault contact. 2: Feedback loss detected when PID enabled. Fault output, operation is stopped and a fault contact is triggered. 3: Feedback loss detection when PID disabled by digital input. No alarm/fault output. "PID feedback loss" digital output is switched. 4: PID Feedback error detection when PID disabled by digital input. An alarm is triggered and the drive continues to run. 5: PID Feedback error detection when PID disabled by digital input. Fault is triggered and output is shut off.
b5-13	PID Feedback Loss Detection Level	Sets the PID feedback loss detection level.
b5-14	PID Feedback Loss Detection Time	Sets the PID feedback loss detection delay time.
b5-15	PID Sleep Function Start Level	Refer to V1000 Technical Manual for details.
b5-16	PID Sleep Delay Time	Refer to V1000 Technical Manual for details.
b5-17	PID Accel/Decel Time	Refer to V1000 Technical Manual for details.
b5-18	PID Setpoint Selection	Refer to V1000 Technical Manual for details.
b5-19	PID Setpoint Value	Refer to V1000 Technical Manual for details.
b5-20	PID Setpoint Scaling	Refer to V1000 Technical Manual for details.
b5-34	PID Output Lower Limit	Refer to V1000 Technical Manual for details.
b5-35	PID Input Limit	Refer to V1000 Technical Manual for details.
b5-36	PID Feedback High Detection Level	Refer to V1000 Technical Manual for details.
b5-37	PID Feedback High Level Detection Time	Refer to V1000 Technical Manual for details.
b5-38	PID Setpoint / User Display	Refer to V1000 Technical Manual for details.
b5-39	PID Setpoint Display Digits	Refer to V1000 Technical Manual for details.
b5-40	Frequency Reference Monitor Content during PID	Refer to V1000 Technical Manual for details. <b>NOTE:</b> Available in software versions PRG:1014 and higher.
<b>b6: Dwell Function</b> Use b6 parameters to configure dwell function operation.		
b6-01	Dwell Reference at Start	Refer to V1000 Technical Manual for details.
b6-02	Dwell Time at Start	
b6-03	Dwell Frequency at Stop	
b6-04	Dwell Time at Stop	
<b>b8: Energy Saving</b> Use b8 parameters to configure the energy saving/conservation drive function.		
b8-01	Energy Saving Control Selection	0: Disabled 1: Enabled (set b8-04)
b8-02	Energy Saving Gain	Refer to V1000 Technical Manual for details.

## 7.1 Parameter Table

No.	Name	Description
b8-03	Energy Saving Control Filter Time Constant	Refer to V1000 Technical Manual for details.
b8-04	Energy Saving Coefficient Value	Sets the Energy Saving coefficient and is used to fine adjustments in V/f Control.
b8-05	Power Detection Filter Time	Sets a filter time for the Power Detection used by Energy Savings in V/f Control.
b8-06	Search Operation Voltage Limit	Sets the limit for the voltage search operation performed by Energy Savings in V/f Control.
<b>C1: Acceleration and Deceleration Times</b>		
Use C1 parameters to configure motor acceleration and deceleration.		
C1-01	Acceleration Time 1	Sets the time to accelerate from 0 to maximum frequency.
C1-02	Deceleration Time 1	Sets the time to decelerate from maximum frequency to 0.
C1-03	Acceleration Time 2	Sets the time to accelerate from 0 to maximum frequency when Accel/Decel times 2 are selected by a digital input.
C1-04	Deceleration Time 2	Sets the time to decelerate from maximum frequency to 0 when Accel/Decel times 2 are selected by a digital input.
C1-05	Acceleration Time 3 (Motor 2 Accel Time 1)	Sets the time to accelerate from 0 to maximum frequency when Accel/Decel times 3 are selected by a digital input.
C1-06	Deceleration Time 3 (Motor 2 Decel Time 1)	Sets the time to decelerate from maximum frequency to 0 when Accel/Decel times 3 are selected by a digital input.
C1-07	Acceleration Time 4 (Motor 2 Accel Time 2)	Sets the time to accelerate from 0 to maximum frequency when Accel/Decel times 4 are selected by a digital input.
C1-08	Deceleration Time 4 (Motor 2 Decel Time 2)	Sets the time to decelerate from maximum frequency to 0 when Accel/Decel times 4 are selected by a digital input.
C1-09	Fast-Stop Time	Refer to V1000 Technical Manual for details.
C1-10	Accel/Decel Time Setting Units	0: 0.01 s (0.00 to 600.00 s) 1: 0.1 s (0.0 to 6000.0 s)
C1-11	Accel/Decel Time Switching Frequency	Refer to V1000 Technical Manual for details.
<b>C2: S-Curve Characteristics</b>		
Use C2 parameters to configure S-curve operation.		
C2-01	S-Curve Characteristic at Accel Start	S-curve is used to further soften the starting and stopping ramp. The longer the S-curve time, the softer the starting and stopping ramp.
C2-02	S-Curve Characteristic at Accel End	
C2-03	S-Curve Characteristic at Decel Start	
C2-04	S-Curve Characteristic at Decel End	
<b>C3: Slip Compensation</b>		
Use C3 parameters to configure the slip compensation function.		
C3-01	Slip Compensation Gain	Sets the slip compensation gain.
C3-02	Slip Compensation Primary Delay Time	Adjusts the slip compensation function delay time.

## 7.1 Parameter Table

No.	Name	Description
C3-03	Slip Compensation Limit	Refer to V1000 Technical Manual for details.
C3-04	Slip Compensation Selection during Regeneration	0: Disabled 1: Enabled
C3-05	Output Voltage Limit Operation Selection	Refer to V1000 Technical Manual for details.
<b>C4: Torque Compensation</b> Use C4 parameters to configure Torque Compensation function.		
C4-01	Torque Compensation Gain	V/f control: Sets the gain for the automatic torque (voltage) boost function and helps to produce better starting torque. Open Loop Vector: Sets the torque compensation function gain. Normally no change is required.
C4-02	Torque Compensation Primary Delay Time	Sets the torque compensation filter time.
C4-03	Torque Compensation at Forward Start	Refer to V1000 Technical Manual for details.
C4-04	Torque Compensation at Reverse Start	Refer to V1000 Technical Manual for details.
C4-05	Torque Compensation Time Constant	Refer to V1000 Technical Manual for details.
C4-06	Torque Compensation Primary Delay Time 2	Refer to V1000 Technical Manual for details.
<b>C5: Speed Control (ASR)</b> Use C5 parameters to configure the Automatic Speed Regulator (ASR). C5 parameters are available only when using V/f with Simple PG (H6-01 = 3).		
C5-01	ASR Proportional Gain 1	Refer to V1000 Technical Manual for details.
C5-02	ASR Integral Time 1	Refer to V1000 Technical Manual for details.
C5-03	ASR Proportional Gain 2	Refer to V1000 Technical Manual for details.
C5-04	ASR Integral Time 2	Refer to V1000 Technical Manual for details.
C5-05	ASR Limit	Refer to V1000 Technical Manual for details.
<b>C6: Carrier Frequency</b> Use C6 parameters to configure the carrier frequency drive settings.		
C6-01	Normal/Heavy Duty Selection	Refer to V1000 Technical Manual for details.
C6-02	Carrier Frequency Selection	1: 2.0 kHz 2: 5.0 kHz 3: 8.0 kHz 4: 10.0 kHz 5: 12.5 kHz 6: 15.0 kHz 7: Swing PWM1 (Audible sound 1) 8: Swing PWM2 (Audible sound 2) 9: Swing PWM3 (Audible sound 3) A: Swing PWM4 (Audible sound 4) B to E: No setting possible F: User defined (determined by C6-03 through C6-05)

## 7.1 Parameter Table

No.	Name	Description
C6-03	Carrier Frequency Upper Limit	Refer to V1000 Technical Manual for details.
C6-04	Carrier Frequency Lower Limit	
C6-05	Carrier Frequency Proportional Gain	Refer to V1000 Technical Manual for details.
<b>d1: Frequency Reference</b> Use d1 parameters to configure the drive frequency reference.		
d1-01	Frequency Reference 1	Frequency reference. <i>Refer to Frequency Reference Source: b1-01 on page 103</i> for instructions to use d1-01 as the main frequency reference.
d1-02	Frequency Reference 2	Frequency reference when digital input “Multi-Step Speed Reference 1” (H1-□□ = 3) is on.
d1-03	Frequency Reference 3	Frequency reference when digital input “Multi-Step Speed Reference 2” (H1-□□ = 4) is on.
d1-04	Frequency Reference 4	Frequency reference when digital inputs “Multi-Step Speed Reference 1, 2” (H1-□□ = 3 and 4) are on.
d1-05	Frequency Reference 5	Frequency reference when digital input “Multi-Step Speed Reference 3” (H1-□□ = 5) is on.
d1-06	Frequency Reference 6	Frequency reference when digital inputs “Multi-Step Speed Reference 1, 3” (H1-□□ = 3 and 5) are on.
d1-07	Frequency Reference 7	Frequency reference when digital inputs “Multi-Step Speed Reference 2, 3” (H1-□□ = 4 and 5) are on.
d1-08	Frequency Reference 8	Frequency reference when multi-function input “Multi-Step speed reference 1, 2, 3” (H1-□□ = 3, 4, 5) are on.
d1-09	Frequency Reference 9	Frequency reference when multi-function input “Multi-Step Speed Reference 4” (H1-□□ = 32) is on.
d1-10	Frequency Reference 10	Frequency reference when digital input “Multi-Step Speed Reference 1, 4” (H1-□□ = 3 and 32) are on.
d1-11	Frequency Reference 11	Frequency reference when digital inputs “Multi-Step Speed Reference 2, 4” (H1-□□ = 4 and 32) are on.
d1-12	Frequency Reference 12	Frequency reference when digital inputs “Multi-Step Speed Reference 1, 2, 4” (H1-□□ = 3, 4, 32) are on.
d1-13	Frequency Reference 13	Frequency reference when digital inputs “Multi-Step Speed Reference 3, 4” (H1-□□ = 5 and 32) are on.
d1-14	Frequency Reference 14	Frequency reference when digital inputs “Multi-Step Speed Reference 1, 3, 4” (H1-□□ = 3, 5, 32) are on.
d1-15	Frequency Reference 15	Frequency reference when digital inputs “Multi-Step Speed Reference 2, 3, 4” (H1-□□ = 4, 5, 32) are on.
d1-16	Frequency Reference 16	Frequency reference when digital inputs “Multi-Step Speed Reference 1, 2, 3, 4” (H1-□□ = 3, 4, 5, 32) are on.
d1-17	Jog Frequency Reference	Frequency reference when digital inputs “Jog Frequency Reference,” “Forward Jog” or “Reverse Jog.” are on.
<b>d2: Frequency Upper and Lower Limits</b> Use d2 parameters to configure the frequency reference limits.		

No.	Name	Description
d2-01	Frequency Reference Upper Limit	Sets the frequency reference upper limit as a percentage of maximum output frequency (E1-04).
d2-02	Frequency Reference Lower Limit	Sets the frequency reference lower limit as a percentage of maximum output frequency (E1-04).
d2-03	Master Speed Reference Lower Limit	Refer to V1000 Technical Manual for details.
<b>d3: Jump Frequency</b> Use d3 parameters to configure the drive Jump Frequency settings.		
d3-01	Jump Frequency 1	d3-01 to d3-04 allow programming of three prohibited frequency reference points for eliminating problems with resonant vibration of the motor / machine.
d3-02	Jump Frequency 2	
d3-03	Jump Frequency 3	
d3-04	Jump Frequency Width	This parameter sets the dead-band width around each selected prohibited frequency reference point.
<b>d4: Frequency Reference Hold</b> Use d4 parameters to configure the drive frequency reference hold function.		
d4-01	Frequency Reference Hold Function Selection	0: Disabled 1: Enabled
d4-03	Frequency Reference Bias Step (Up/Down 2)	Sets the bias added to the frequency reference when the Up/Down 2 digital inputs are set.
d4-04	Frequency Reference Accel/Decel (Up/Down 2)	0: Adjusts bias value according to currently selected accel/decel time. 1: Adjusts the bias value by Accel/Decel Time 4 (C1-07 and C1-08).
d4-05	Frequency Reference Bias Operation Mode Selection (Up/Down 2)	0: Holds the bias value when Up/Down 2 reference is on or off. 1: When the Up 2 reference and Down 2 reference are both on or both off, applied bias becomes 0 using currently selected accel/ decel. times.
d4-06	Frequency Reference Bias (Up/Down 2)	Saves the bias value once the frequency reference is adjusted.
d4-07	Analog Frequency Reference Fluctuation Limit (Up/Down 2)	When the Up 2 and Down 2 commands are enabled, the frequency reference holds the bias value as the levels for the analog frequency reference or pulse train frequency reference change, accelerating or decelerating to the frequency reference.
d4-08	Frequency Reference Bias Upper Limit (Up/Down 2)	When d4-06 is greater than d4-08, d4-08 becomes bias for upper limit.
d4-09	Frequency Reference Bias Lower Limit (Up/Down 2)	When d4-06 is less than d4-09, d4-09 becomes bias for lower limit.
d4-10	Up/Down Frequency Reference Limit Selection	0: Lower Limit is determined by d2-02 or analog input. 1: Lower Limit is determined by d2-02.
<b>d7: Offset Frequency</b> Use d7 parameters to set the offset frequency.		
d7-01	Offset Frequency 1	Refer to V1000 Technical Manual for details.
d7-02	Offset Frequency 2	Refer to V1000 Technical Manual for details.
d7-03	Offset Frequency 3	Refer to V1000 Technical Manual for details.

## 7.1 Parameter Table

No.	Name	Description
<b>E1: V/f Pattern Characteristics</b>		
Use E1 parameters to set V/f characteristics for the motor.		
E1-01	Input Voltage Setting	Refer to V1000 Technical Manual for details.
E1-03	V/f Pattern Selection	Refer to V1000 Technical Manual for details.
E1-04	Max Output Frequency	Only applicable when E1-03 is set to F.
E1-05	Max Voltage	Only applicable when E1-03 is set to F.
E1-06	Base Frequency	Only applicable when E1-03 is set to F.
E1-07	Mid Output Freq.	Only applicable when E1-03 is set to F. To set linear V/f characteristics, set the same values for E1-07 and E1-09.
E1-08	Mid Output Frequency Voltage	Only applicable when E1-03 is set to F.
E1-09	Minimum Output Freq.	Only applicable when E1-03 is set to F. To set linear V/f characteristics, set the same values for E1-07 and E1-09.
E1-10	Minimum Output Freq. Volt.	Only applicable when E1-03 is set to F.
E1-11	Mid Output Frequency 2	Only applicable when E1-03 is set to F.
E1-12	Mid Output Frequency Voltage 2	Only applicable when E1-03 is set to F.
E1-13	Base Voltage	Only applicable when E1-03 is set to F.
<b>E2: Motor Parameters</b>		
Use E2 parameters to set motor-related data.		
E2-01	Motor Rated Current	Sets motor nameplate full load current in amperes (A).
E2-02	Motor Rated Slip	Sets the motor rated slip in hertz (Hz).
E2-03	Motor No-Load Current	Sets the magnetizing current of the motor as a percentage of the motor rated current (E2-01).
E2-04	Number of Motor Poles	Refer to V1000 Technical Manual for details.
E2-05	Motor Line-to-Line Resistance	Sets the phase-to-phase motor resistance in ohms.
E2-06	Motor Leakage Inductance	Sets the voltage drop due to motor leakage inductance as a percentage of motor rated voltage.
E2-07	Motor Iron-Core Saturation Coefficient 1	Refer to V1000 Technical Manual for details.
E2-08	Motor Iron-Core Saturation Coefficient 2	Refer to V1000 Technical Manual for details.
E2-09	Motor Mechanical Loss	Refer to V1000 Technical Manual for details.
E2-10	Motor Iron Loss for Torque Compensation	Sets the motor iron loss in watts (W).
E2-11	Motor Rated Output	Sets the motor rated power in kilowatts (kW).
E2-12	Motor Iron-Core Saturation Coefficient 3	Refer to V1000 Technical Manual for details.
<b>E3: Motor 2 V/f Characteristics</b>		
Use E3 parameters to set the V/f pattern for a second motor.		
E3-01	Motor 2 Control Method	Refer to V1000 Technical Manual for details.

## 7.1 Parameter Table

No.	Name	Description
E3-04	Motor 2 Max Output Frequency	Refer to V1000 Technical Manual for details.
E3-05	Motor 2 Max Voltage	Refer to V1000 Technical Manual for details.
E3-06	Motor 2 Base Frequency	Refer to V1000 Technical Manual for details.
E3-07	Motor 2 Mid Output Freq.	Refer to V1000 Technical Manual for details.
E3-08	Motor 2 Mid Output Freq. Voltage	Refer to V1000 Technical Manual for details.
E3-09	Motor 2 Min. Output Freq.	Refer to V1000 Technical Manual for details.
E3-10	Motor 2 Min. Output Freq. Voltage	Refer to V1000 Technical Manual for details.
E3-11	Motor 2 Mid Output Frequency 2	Refer to V1000 Technical Manual for details.
E3-12	Motor 2 Mid Output Frequency Voltage 2	Refer to V1000 Technical Manual for details.
E3-13	Motor 2 Base Voltage	Refer to V1000 Technical Manual for details.
<b>E4: Motor 2 Parameters</b>		
Use E4 parameters to control a second motor operating on the same drive.		
E4-01	Motor 2 Rated Current	Refer to V1000 Technical Manual for details.
E4-02	Motor 2 Rated Slip	Refer to V1000 Technical Manual for details.
E4-03	Motor 2 Rated No-Load Current	Refer to V1000 Technical Manual for details.
E4-04	Motor 2 Motor Poles	Refer to V1000 Technical Manual for details.
E4-05	Motor 2 Line-to-Line Resistance	Refer to V1000 Technical Manual for details.
E4-06	Motor 2 Leakage Inductance	Refer to V1000 Technical Manual for details.
E4-07	Motor 2 Motor Iron-Core Saturation Coefficient 1	Refer to V1000 Technical Manual for details.
E4-08	Motor 2 Motor Iron-Core Saturation Coefficient 2	Refer to V1000 Technical Manual for details.
E4-09	Motor 2 Mechanical Loss	Refer to V1000 Technical Manual for details.
E4-10	Motor 2 Iron Loss	Refer to V1000 Technical Manual for details.
E4-11	Motor 2 Rated Capacity	Refer to V1000 Technical Manual for details.
E4-12	Motor 2 Iron-Core Saturation Coefficient 3	Refer to V1000 Technical Manual for details.
E4-14	Motor 2 Slip Compensation Gain	Refer to V1000 Technical Manual for details.
E4-15	Torque Compensation Gain - Motor 2	Refer to V1000 Technical Manual for details.
<b>E5: PM Motor Parameters</b>		
E5-01	Motor Code Selection (for PM motor)	Refer to V1000 Technical Manual for details.
E5-02	Motor Rated Capacity (for PM motor)	Refer to V1000 Technical Manual for details.
E5-03	Motor Rated Current	Refer to V1000 Technical Manual for details.
E5-04	Motor Poles	Refer to V1000 Technical Manual for details.

## 7.1 Parameter Table

No.	Name	Description
E5-05	Motor Resistance	Refer to V1000 Technical Manual for details.
E5-06	Motor d Axis Inductance	Refer to V1000 Technical Manual for details.
E5-07	Motor q Axis Inductance	Refer to V1000 Technical Manual for details.
E5-09	Motor Induction Voltage Constant 1	Refer to V1000 Technical Manual for details.
E5-24	Motor Induction Voltage Constant 2	Refer to V1000 Technical Manual for details.
<b>F1: Simple PG V/f Parameters</b>		
Use F1 parameters to set up the drive for Simple PG V/f control. These parameters are enabled only when H6-01 = 03		
F1-02	Operation Selection at PG Open Circuit (PGO)	Refer to V1000 Technical Manual for details.
F1-03	Operation Selection at Overspeed (OS)	Refer to V1000 Technical Manual for details.
F1-04	Operation Selection at Deviation	Refer to V1000 Technical Manual for details.
F1-08	Overspeed Detection Level	Refer to V1000 Technical Manual for details.
F1-09	Overspeed Detection Delay Time	Refer to V1000 Technical Manual for details.
F1-10	Excessive Speed Deviation Detection Level	Refer to V1000 Technical Manual for details.
F1-11	Excessive Speed Deviation Detection Delay Time	Refer to V1000 Technical Manual for details.
F1-14	PG Open-Circuit Detection Time	Refer to V1000 Technical Manual for details.
<b>F6 and F7: Serial Communications Option Card Settings</b>		
Use F6 parameters to program the drive for serial communication.		
F6-01	Communications Error Operation Selection	Refer to V1000 Technical Manual for details.
F6-02	External Fault from Comm. Option Detection Selection	Refer to V1000 Technical Manual for details.
F6-03	External Fault from Comm. Option Operation Selection	Refer to V1000 Technical Manual for details.
F6-04	bUS Error Detection Time	Refer to V1000 Technical Manual for details.
F6-06	Torque Reference/Torque Limit Selection from Comm. Option	Refer to V1000 Technical Manual for details.
F6-07	NetRef/ComRef Function Selection	Refer to V1000 Technical Manual for details. <b>NOTE:</b> Available in software versions PRG:1014 and higher.
F6-08	Reset Communication Parameters	Refer to V1000 Technical Manual for details. <b>NOTE:</b> Available in software versions PRG:1014 and higher.
F6-10	CC-Link Node Address	Refer to V1000 Technical Manual for details.
F6-11	CC-Link Communication Speed	Refer to V1000 Technical Manual for details.
F6-14	CC-Link bUS Error Auto Reset	Refer to V1000 Technical Manual for details.
F6-20	MECHATROLINK Station Address	Refer to V1000 Technical Manual for details.
F6-21	MECHATROLINK Frame Length	Refer to V1000 Technical Manual for details.

## 7.1 Parameter Table

No.	Name	Description
F6-22	MECHATROLINK Link Speed	Refer to V1000 Technical Manual for details.
F6-23	MECHATROLINK Mon E Register	Refer to V1000 Technical Manual for details.
F6-24	MECHATROLINK Mon F Register	Refer to V1000 Technical Manual for details.
F6-30	PROFIBUS-DP Node Address	Refer to V1000 Technical Manual for details.
F6-31	PROFIBUS-DP Clear Mode Selection	Refer to V1000 Technical Manual for details.
F6-32	PROFIBUS-DP Data Format Selection	Refer to V1000 Technical Manual for details.
F6-35	CANopen Node ID Selection	Refer to V1000 Technical Manual for details.
F6-36	CANopen Communication Speed	Refer to V1000 Technical Manual for details.
F6-40	CompoNet Node address	Refer to V1000 Technical Manual for details.
F6-41	CompoNet Communication Speed	Refer to V1000 Technical Manual for details.
F6-50	DeviceNet MAC Address	Refer to V1000 Technical Manual for details. <b>NOTE:</b> Available in software versions PRG:1011 and higher.
F6-51	DeviceNet Communication Speed	Refer to V1000 Technical Manual for details. <b>NOTE:</b> Available in software versions PRG:1011 and higher.
F6-52	DeviceNet PCA Setting	Refer to V1000 Technical Manual for details. <b>NOTE:</b> Available in software versions PRG:1011 and higher.
F6-53	DeviceNet PPA Setting	Refer to V1000 Technical Manual for details. <b>NOTE:</b> Available in software versions PRG:1011 and higher.
F6-54	DeviceNet Idle Mode Fault Detection	Refer to V1000 Technical Manual for details. <b>NOTE:</b> Available in software versions PRG:1011 and higher.
F6-55	DeviceNet Baud Rate Monitor	Refer to V1000 Technical Manual for details. <b>NOTE:</b> Available in software versions PRG:1012 and higher.
F6-56	DeviceNet Speed Scaling	Refer to V1000 Technical Manual for details. <b>NOTE:</b> Available in software versions PRG:1011 and higher.
F6-57	DeviceNet Current Scaling	Refer to V1000 Technical Manual for details. <b>NOTE:</b> Available in software versions PRG:1011 and higher.
F6-58	DeviceNet Torque Scaling	Refer to V1000 Technical Manual for details. <b>NOTE:</b> Available in software versions PRG:1011 and higher.
F6-59	DeviceNet Power Scaling	Refer to V1000 Technical Manual for details. <b>NOTE:</b> Available in software versions PRG:1011 and higher.
F6-60	DeviceNet Voltage Scaling	Refer to V1000 Technical Manual for details. <b>NOTE:</b> Available in software versions PRG:1011 and higher.
F6-61	DeviceNet Time Scaling	Refer to V1000 Technical Manual for details. <b>NOTE:</b> Available in software versions PRG:1011 and higher.
F6-62	DeviceNet Heartbeat Interval	Refer to V1000 Technical Manual for details. <b>NOTE:</b> Available in software versions PRG:1011 and higher.

## 7.1 Parameter Table

No.	Name	Description
F6-63	Dynamic Output Assembly 109 Parameter 1 <b>NOTE:</b> Function available in versions PRG:1012 and lower.	Refer to V1000 Technical Manual for details.
	MAC ID Memory <b>NOTE:</b> Function available in versions PRG:1014 and higher.	
F6-64	Dynamic Output Assembly 109 Parameter 2 <b>NOTE:</b> Function available in versions PRG:1012 and lower.	Refer to V1000 Technical Manual for details.
	Dynamic Output Assembly 109 Parameter 1 <b>NOTE:</b> Function available in versions PRG:1014 and higher.	
F6-65	Dynamic Output Assembly 109 Parameter 3 <b>NOTE:</b> Function available in versions PRG:1012 and lower.	Refer to V1000 Technical Manual for details.
	Dynamic Output Assembly 109 Parameter 2 <b>NOTE:</b> Function available in versions PRG:1014 and higher.	
F6-66	Dynamic Output Assembly 109 Parameter 4 <b>NOTE:</b> Function available in versions PRG:1012 and lower.	Refer to V1000 Technical Manual for details.
	Dynamic Output Assembly 109 Parameter 3 <b>NOTE:</b> Function available in versions PRG:1014 and higher.	
F6-67	Dynamic Output Assembly 159 Parameter 1 <b>NOTE:</b> Function available in versions PRG:1012 and lower.	Refer to V1000 Technical Manual for details.
	Dynamic Output Assembly 109 Parameter 4 <b>NOTE:</b> Function available in versions PRG:1014 and higher.	
F6-68	Dynamic Output Assembly 159 Parameter 2 <b>NOTE:</b> Function available in versions PRG:1012 and lower.	Refer to V1000 Technical Manual for details.
	Dynamic Output Assembly 159 Parameter 1 <b>NOTE:</b> Function available in versions PRG:1014 and higher.	

No.	Name	Description
F6-69	Dynamic Output Assembly 159 Parameter 3 <b>NOTE:</b> Function available in versions PRG:1012 and lower.	Refer to V1000 Technical Manual for details.
	Dynamic Output Assembly 159 Parameter 2 <b>NOTE:</b> Function available in versions PRG:1014 and higher.	
F6-70	Dynamic Output Assembly 159 Parameter 4 <b>NOTE:</b> Function available in versions PRG:1012 and lower.	Refer to V1000 Technical Manual for details.
	Dynamic Output Assembly 159 Parameter 3 <b>NOTE:</b> Function available in versions PRG:1014 and higher.	
F6-71	Dynamic Output Assembly 159 Parameter 4 <b>NOTE:</b> Function available in versions PRG:1014 and higher.	Refer to V1000 Technical Manual for details.
F7-01 to F7-22	EtherNet Option Parameters	Refer to EtherNet Option Technical Manual for details.

No.	Name	Description
<b>H1: Multi-Function Digital Input</b>		
H1 parameters to assign functions to the multi-function digital input terminals. Unused terminals should be set to “F”.		
H1-01	Multi-Function Digital Input Terminal S1 Function Selection	Selects function of terminal S1
H1-02	Multi-Function Digital Input Terminal S2 Function Selection	Selects function of terminal S2
H1-03	Multi-Function Digital Input Terminal S3 Function Selection	Selects function of terminal S3
H1-04	Multi-Function Digital Input Terminal S4 Function Selection	Selects function of terminal S4
H1-05	Multi-Function Digital Input Terminal S5 Function Selection	Selects function of terminal S5
H1-06	Multi-Function Digital Input Terminal S6 Function Selection	Selects function of terminal S6
H1-07	Multi-Function Digital Input Terminal S7 Function Selection	Selects function of terminal S7

<b>H1 Multi-Function Digital Input Selections</b>		
H1-□□ Setting	Function	Description
0	3-Wire Sequence	Closed: Reverse rotation (only for 3-wire sequence)
1	Local/Remote Selection	Open: Remote, Reference 1 or 2 (b1-01/02 or b1-15/16) Closed: Local, LED operator is run and reference source
2	External Reference 1/2	Open: Run and frequency reference source 1 (b1-01/02) Closed: Run and frequency reference source 2 (b1-01/02)

## 7.1 Parameter Table

H1 Multi-Function Digital Input Selections		
H1-□□ Setting	Function	Description
3	Multi-Step Speed Reference 1	Used to select Multi-Step Speeds set in d1-01 to d1-16
4	Multi-Step Speed Reference 2	
5	Multi-Step Speed Reference 3	
6	Jog Reference Selection	Open: Selected speed reference Closed: Jog Frequency reference (d1-17). Jog has priority over all other reference sources.
7	Accel/Decel Time 1	Used to switch between Accel/Decel. Time 1/2
8	Baseblock Command (N.O.)	Open: Normal operation Closed: No drive output
9	Baseblock Command (N.C.)	Open: No drive output Closed: Normal operation
A	Accel/Decel Ramp Hold	Closed: The drive pauses during acceleration or deceleration and maintains the output frequency.
B	Drive Overheat Alarm (oH2)	Closed: Displays an oH2 alarm
C	Terminal A1/A2 Enable	Open: Function assigned by H3-14 is disabled Closed: Function assigned by H3-14 is enabled
F	Not used	Select this setting when not using the terminal or when using the terminal in a pass-through mode.
10	Up Command	Open: Maintains the current frequency reference Closed: Increases or decreases the current frequency reference
11	Down Command	
12	Forward Jog	Closed: Runs forward at the Jog Frequency d1-17.
13	Reverse Jog	Closed: Runs reverse at the Jog Frequency d1-17.
14	Fault Reset	Closed: Resets faults if cause is cleared and Run command removed.
15	Fast-Stop (N.O.)	Closed: Decelerates at the Fast-Stop time C1-09.
16	Motor 2 Selection	Open: Motor 1 (E1-□□, E2-□□) Closed: Motor 2 (E3-□□, E4-□□)
17	Fast-stop (N.C.)	Open: Decelerates according to C1-09 (Fast-stop Time)
18	Timer Input Function	Set the timer delay using parameters b4-01 and b4-02.
19	PID Disable	Closed: PID control disabled
1A	Accel/Decel Time Selection 2	Switches Accel/Decel times.
1B	Program Lockout	Open: Parameters can not be edited. (except U1-01 if reference source is set for operator) Closed: Parameters may be edited and saved.
1E	Reference Sample Hold	Closed: Samples the analog frequency reference and operates the drive at that speed.

H1 Multi-Function Digital Input Selections		
H1-□□ Setting	Function	Description
20 to 2F	External Fault	20: N.O., Always Detected, Ramp To Stop 21: N.C., Always Detected, Ramp To Stop 22: N.O., During Run, Ramp To Stop 23: N.C., During Run, Ramp To Stop 24: N.O., Always Detected, Coast To Stop 25: N.C., Always Detected, Coast To Stop 26: N.O., During Run, Coast To Stop 27: N.C., During Run, Coast To Stop 28: N.O., Always Detected, Fast-stop 29: N.C., Always Detected, Fast-stop 2A: N.O., During Run, Fast-stop 2B: N.C., During Run, Fast-stop 2C: N.O., Always Detected, Alarm Only (continue running) 2D: N.C., Always Detected, Alarm Only (continue running) 2E: N.O., During Run, Alarm Only (continue running) 2F: N.C., During Run, Alarm Only (continue running)
30	PID Integral Reset	Closed: Resets the PID control integral value.
31	PID Integral Hold	Closed: Maintains the current PID control integral value.
32	Multi-Step Speed Reference 4	Used to select Multi-Step Speeds set in d1-01 to d1-16
34	PID Soft Starter	Closed: Disables the PID soft starter b5-17.
35	PID Input Switch	Closed: Inverses the PID input signal
40	Forward Run Command (2-wire sequence)	Open: Stop Closed: Forward run
41	Reverse Run Command (2-wire sequence)	Open: Stop Closed: Reverse run
42	Run Command (2-wire sequence 2)	Open: Stop Closed: Run
43	FWD/REV Command (2-wire sequence 2)	Open: Reverse Closed: Forward
44	Offset Frequency 1 Addition	Closed: Adds d7-01 to the frequency reference.
45	Offset Frequency 2 Addition	Closed: Adds d7-02 to the frequency reference.
46	Offset Frequency 3 Addition	Closed: Adds d7-03 to the frequency reference.
47	Node Setup	Closed: Node Setup
60	DC Injection Braking Command	Closed: Triggers DC Injection Braking (b2-02)
61	External Search Command 1	Closed: Activates Current Detection Speed Search from the max. output frequency (E1-04) if b3-01 = 0.
62	External Search Command 2	Closed: Activates Current Detection Speed Search from the frequency reference if b3-01 = 0. Activates Speed Estimation Type Speed search if b3-01 = 0.
65	KEB Ride-Thru 1 (N.C.)	Open: KEB Ride-Thru 1 enabled Closed: Normal operation

## 7.1 Parameter Table

H1 Multi-Function Digital Input Selections		
H1-□□ Setting	Function	Description
66	KEB Ride-Thru 1 (N.O.)	Open: Normal operation Closed: KEB Ride-Thru 1 enabled
67	Communications Test Mode	Tests the MEMOBUS/Modbus RS-485/422 interface.
68	High-Slip Braking	Closed: High-Slip braking is executed. Drive stops.
6A	Drive Enable	Open: Drive disabled. If this input is opened during run, then the drive will stop as specified by parameter b1-03. Closed: Ready for operation.
75	Up 2 Command	Open: Maintains the current frequency reference
76	Down 2 Command	Closed: Increases or decreases the frequency reference.
7A	KEB Ride-Thru 2 (N.C.)	Open: KEB Ride-Thru 2 enabled Closed: Normal operation
7B	KEB Ride-Thru 2 (N.O.)	Open: Normal operation Closed: KEB Ride-Thru 2 enabled
7C	Short-Circuit Braking (N.O.)	Open: Normal operation
7D	Short-Circuit Braking (N.C.)	Closed: Short-Circuit Braking
7E	Forward/Reverse Detection	Direction of rotation detection (for Simple V/f w/PG)
90 to 96	DriveWorksEZ Digital Input 1 to 7	These settings are for digital input functions used in DriveWorksEZ. Normally there is no need to change or apply these settings.
9F	DriveWorksEZ enable	Open: DWEZ enabled Closed: DWEZ disabled

No.	Name	Description	Range
<b>H2: Multi-Function Digital Outputs</b>			
Use H2 parameters to assign functions to the multi-function digital outputs.			
H2-01	Terminal MA, MB and MC Function Selection (relay)	Refer to “Multi-Function Digital Output Selection Table” for a description of setting values.	0 to 192
H2-02	Terminal P1 Function Selection (open-collector)		
H2-03	Terminal P2 Function Selection (open-collector)		
H2-06	Watt Hour Output Unit Selection	Refer to V1000 Tech Manual.	0 to 4

H2 Multi-Function Digital Output Settings		
H2-□□ Setting	Function	Description
0	During Run	Closed: A Run command is active or voltage is output.
1	Zero Speed	Closed: Output frequency is 0.
2	Speed Agree 1	Closed: Output frequency equals the speed reference (plus or minus the hysteresis set to L4-02).
3	User Set Speed Agree 1	Closed: Output frequency and speed reference equal the value in L4-01 (plus or minus the hysteresis of L4-02).

H2 Multi-Function Digital Output Settings		
H2-□□ Setting	Function	Description
4	Frequency Detection 1	Closed: Output frequency is less than or equal to the value in L4-01 with hysteresis determined by L4-02.
5	Frequency Detection 2	Closed: Output frequency is greater than or equal to the value in L4-01, with hysteresis determined by L4-02.
6	Drive Ready	Closed: Drive Ready. The drive is powered up, not in a fault state, and in the Drive mode.
7	DC Bus Undervoltage	Closed: DC bus voltage is below the UV trip level set in L2-05.
8	During Baseblock (N.O.)	Closed: This is no output voltage
9	Frequency Reference Source	Closed: Digital operator supplies the frequency reference.
A	Run Command Source	Open: Reference 1 or 2 are active Closed: Digital operator supplies the run command.
B	Torque Detection 1 (N.O.)	Closed: Output current/torque exceeds the torque value set in parameter L6-02 for longer than the time set in parameter L6-03.
C	Frequency Reference Loss	Closed: Loss of the analog frequency reference detected. Enabled when L4-05 = 1.
D	Braking Resistor Fault	Closed: Braking resistor or transistor is overheated or faulted out.
E	Fault	Closed: Fault occurred (other than CPF00 and CPF01).
F	Not used/Through Mode	Set this value when the terminal is not used, or when using the terminal in the pass-through mode.
10	Alarm	Closed: An alarm is triggered.
11	Reset Command Active	Closed: Reset command to the drive is active.
12	Timer Output	Timer output, controlled by b4-01 and b4-02. Used in conjunction with the digital input (H1-□□ = 18 "timer function").
13	Speed Agree 2	Closed: When drive output frequency equals the frequency reference +/- L4-04.
14	User Set Speed Agree 2	Closed: When the drive output frequency is equal to the value in L4-03 (plus or minus L4-04).
15	Frequency Detection 3	Closed: When the drive output frequency is less than or equal to the value in L4-03 with the hysteresis determined by L4-04.
16	Frequency Detection 4	Closed: When the output frequency is greater than or equal to the value in L4-03 with the hysteresis determined by L4-04.
17	Torque Detection 1 (N.C.)	Open: When the output current/torque exceeds the value set in parameter L6-02 for more time than is set in parameter L6-03.
18	Torque Detection 2 (N.O.)	Closed: When the output current/torque exceeds the value set in parameter L6-05 for more time than is set in parameter L6-06.
19	Torque Detection 2 (N.C.)	Open: Output current/torque exceeds the value set in parameter L6-05 for more time than is set in parameter L6-06.
1A	During Reverse Operation	Closed: Drive is running in the reverse direction.
1B	During Baseblock (N.C.)	Open: Drive is in base block condition. Output is disabled.

## 7.1 Parameter Table

H2 Multi-Function Digital Output Settings		
H2-□□ Setting	Function	Description
1C	Motor 2 Selection	Closed: Motor 2 is selected by a digital input (H1-□□ = 16)
1E	Restart Enabled	Closed: An automatic restart is performed
1F	Motor Overload Alarm (oL1)	Closed: OL1 is at 90% of its trip point or greater.
20	Drive Overheat Pre-alarm (oH)	Closed: Heatsink temperature exceeds the parameter L8-02 value.
22	Mechanical Weakening	Closed: Mechanical Weakening detected.
2F	Maintenance Period	Closed: cooling fan, electrolytic capacitors, IGBTs, or the soft charge bypass relay may require maintenance.
30	During Torque Limit	Closed: When the torque limit has been reached.
37	During Frequency Output	Closed: Frequency is output Open: Operation stopped, Baseblock, DC Injection Braking, or Initial Excitation is being performed.
38	Drive Enable	Closed: Multi-function input closes (H1-□□ = 6A)
39	Watt Hour Pulse Output	Output units are determined by H2-06, outputs 200 ms pulse for each incremented kWh count.
3C	LOCAL/REMOTE Status	Closed: LOCAL Open: REMOTE
3D	During Speed Search	Closed: Speed search is being executed.
3E	PID Feedback Low	Closed: PID Feedback Loss.
3F	PID Feedback High	Closed: PID Feedback Fault.
4A	During KEB Operation	Closed: KEB is being performed.
4B	During Short-Circuit Brake	Closed: Short-Circuit Braking is active.
4C	During Fast-stop	Closed: Fast-stop command is entered
4D	oH Pre-alarm Time Limit	Closed: oH Pre-alarm time limit is passed.
4E	Braking Transistor Fault (rr)	Closed: The built-in dynamic braking transistor failed.
4F	Braking Resistor Overheat (oH)	Closed: The dynamic braking resistor overheated.
90 to 92	DriveWorksEZ Digital Output 1 to 3	These settings are for digital output functions used in DriveWorksEZ. Normally there is no need to change or apply these settings.
100 to 192	H2 Parameter Functions Reversed Output Switching of 0 to 92	Reverse the output switching of the multi-function output functions. Set the last two digits of 1□□ to reverse the output signal of that specific function.

No.	Name	Description
<b>H3: Analog Inputs</b>		
Use H3 parameters to set the multi-function analog input terminals.		
H3-01	Terminal A1 Signal Level Selection	0: 0 to +10 V (lower limit) 1: 0 to +10 V (no lower limit)
H3-02	Terminal A1 Function Selection	Sets the function of terminal A1.

## 7.1 Parameter Table

No.	Name	Description
H3-03	Terminal A1 Gain Setting	Sets the level of the input value selected in H3-02 when 10V is input at terminal A1.
H3-04	Terminal A1 Bias Setting	Sets the level of the input value selected in H3-02 when 0V is input at terminal A1.
H3-09	Terminal A2 Signal Level Selection	Sets the input signal level for terminal A2. 0: 0 to +10 V (with lower limit) 1: 0 to +10 V (no lower limit) 2: 4 to 20 mA 3: 0 to 20 mA
H3-10	Terminal A2 Function Selection	Sets the function of terminal A2.
H3-11	Terminal A2 Gain Setting	Sets the level of the input value selected in H3-10 when 10 V (20 mA) is input at terminal A2.
H3-12	Terminal A2 Input Bias	Sets the level of the input value selected in H3-10 when 0 V (0 or 4 mA) is input at terminal A2.
H3-13	Analog Input Filter Time Constant	Sets the primary delay filter time constant for terminals A1 and A2. Used for noise filtering.
H3-14	Analog Input Terminal Enable Selection	Determines which analog input terminal or terminals will be enabled when a digital input programmed for "Analog input enable" (H1□□□ = C) is activated. 1: Terminal A1 only 2: Terminal A2 only 7: All terminals enabled
H3-16	Multi-Function Analog Input Terminal A1 Offset	Determines the offset for the input signal to Terminal A1.
H3-17	Multi-Function Analog Input Terminal A2 Offset	Determines the offset for the input signal to Terminal A2.

### H3 Multi-Function Analog Input Settings

H3-□□ Setting	Function	Maximum Input Level Possible
0	Frequency Bias	Max output frequency (E1-04).
1	Frequency Gain	Frequency reference (voltage)
2	Auxiliary Frequency Reference (used as multi-step speed 2)	Max output frequency (E1-04)
4	Output Voltage Bias	200 V Class: 200 V 400 V Class: 400 V
7	Overtorque/Undertorque Detection Level	Open Loop Vector: Motor rated torque V/f control: Drive rated current
B	PID Feedback	10V = 100%
C	PID Set Point	10V = 100%
E	Motor Temperature (PTC input)	10 V = 100.00%
F	Not used/Through Mode	—
10	FWD Torque Limit	Motor rated torque

## 7.1 Parameter Table

H3 Multi-Function Analog Input Settings		
H3-□□ Setting	Function	Maximum Input Level Possible
11	REV Torque Limit	Motor rated torque
12	Regenerative Torque Limit	Motor rated torque
15	FWD/REV Torque Limit	Motor rated torque
16	Differential PID Feedback	10 V = 100%
30/31	DriveWorksEZ Analog Input 1/2	These settings are for analog output functions used in DriveWorksEZ. Normally there is no need to change or apply these settings.
41	V/f Gain	10 V = 100.00%

No.	Name	Description
<b>H4: Multi-Function Analog Outputs</b>		
Use H4 parameters to configure the multi-function analog output terminals.		
H4-01	Multi-Function Analog Output Terminal AM)	Selects data output via multi-function analog output terminal AM.
H4-02	Multi-Function Analog Output Terminal AM Gain	Sets terminal AM output level when selected monitor is at 100%.
H4-03	Multi-Function Analog Output Terminal AM Gain	Refer to V1000 Technical Manual for details.
<b>H5: MEMOBUS/Modbus Communications</b>		
Use H5 Parameters to connect the drive to a MEMOBUS/Modbus network.		
H5-01	Drive Node Address	Selects drive station node number (address) for MEMOBUS/Modbus terminals R+, R-, S+, S-. Cycle power for the setting to take effect.
H5-02	Communication Speed Selection	0: 1200 bps 1: 2400 bps 2: 4800 bps 3: 9600 bps 4: 19200 bps 5: 38400 bps 6: 57600 bps 7: 76800 bps 8: 115200 bps
H5-03	Communication Parity Selection	0: No parity 1: Even parity 2: Odd parity
H5-04	Stopping Method After Communication Error	0: Ramp to stop 1: Coast to stop 2: Fast-stop 3: Alarm only
H5-05	Communication Fault Detection Selection	0: Disabled 1: Enabled - If communication is lost for more than two seconds, a CE fault will occur.
H5-06	Drive Transmit Wait Time	Set the wait time between receiving and sending data.

No.	Name	Description
H5-07	RTS Control Selection	0: Disabled - RTS is always on. 1: Enabled - RTS turns on only when sending.
H5-09	CE Detection Time	Refer to V1000 Technical Manual for details.
H5-10	Unit Selection for MEMOBUS/ Modbus Register 0025H	Refer to V1000 Technical Manual for details.
H5-11	Communications ENTER Function Selection	Refer to V1000 Technical Manual for details.
H5-12	Run Command Method Selection	Refer to V1000 Technical Manual for details.
<b>H6: Pulse Train Input/Output</b> Use H6 parameters to configure Pulse Train I/O operation.		
H6-01	Pulse Train Input Terminal RP Function Selection	0: Frequency reference 1: PID feedback value 2: PID setpoint value 3: Simple PG V/f control mode (can be set only when using motor 1 in the V/f control mode)
H6-02	Pulse Train Input Scaling	Sets the number of pulses (Hz) that is equal to 100% of the value selected in H6-01.
H6-03	Pulse Train Input Gain	Sets the level of the value selected in H6-01 when a frequency with the value set in H6-02 is input.
H6-04	Pulse Train Input Bias	Sets the level of the value selected in H6-01 when 0 Hz is input.
H6-05	Pulse Train Input Filter Time	Sets the pulse train input filter time constant.
H6-06	Pulse Train Monitor Terminal MP Selection	Select the pulse train monitor output function (value of the □-□□ part of U□-□□).
H6-07	Pulse Train Monitor Scaling	Sets the pulse output frequency in Hz when the monitor value is 100%.
<b>L1: Motor Protection Functions</b> Use L1 parameters to configure motor protective functions.		
L1-01	Motor Overload Protection Selection	0: Disabled 1: Standard Fan-Cooled Motor 2: Drive Duty Motor with a Speed Range of 1:10 3: Drive Duty Motor with a Speed Range of 1:100 4: Permanent Magnet Motor 6: Customized Motor (50 Hz) <b>NOTICE:</b> <i>The thermal protection is reset when the power is cycled. In applications where the power is frequently cycled, the drive may not be able to provide protection, even if this parameter is set to 1. Set to "0" and ensure each motor has a thermal relay installed.</i>
L1-02	Motor Overload Protection Time	Sets the motor thermal overload protection (OL1) time.
L1-03	Motor Overheat Alarm Operation Selection (PTC input)	Refer to V1000 Technical Manual for details.
L1-04	Motor Overheat Fault Operation Selection (PTC input)	Refer to V1000 Technical Manual for details.
L1-05	Motor Temperature Input Filter Time (PTC input)	Refer to V1000 Technical Manual for details.

## 7.1 Parameter Table

No.	Name	Description
L1-13	Continuous Electrothermal Operation Selection	Refer to V1000 Technical Manual for details.
<b>L2: Momentary Power Loss</b>		
Use L2 parameters to configure drive functions for momentary power loss conditions.		
L2-01	Momentary Power Loss Operation Selection	0: Disabled - Drive trips on (UV1) fault when power is lost. 1: Power Loss Ride-Thru Time - Drive will restart if power returns within the time set in L2-02. 2: CPU Power Active - Drive will restart if power returns as long as the CPU is working.
L2-02	Momentary Power Loss Ride-Thru Time	Refer to V1000 Technical Manual for details.
L2-03	Momentary Power Loss Minimum Baseblock Time	Refer to V1000 Technical Manual for details.
L2-04	Momentary Power Loss Voltage Recovery Ramp Time	Refer to V1000 Technical Manual for details.
L2-05	Undervoltage Detection Level (UV)	Refer to V1000 Technical Manual for details.
L2-06	KEB Deceleration Time	Refer to V1000 Technical Manual for details.
L2-07	KEB Acceleration Time	Refer to V1000 Technical Manual for details.
L2-08	KEB Start Output Frequency Reduction	Refer to V1000 Technical Manual for details.
L2-11	Desired DC Bus Voltage during KEB	Refer to V1000 Technical Manual for details.
<b>L3: Stall Prevention Function</b>		
Use L3 parameters to configure the stall prevention function.		
L3-01	Stall Prevention Selection during Acceleration	Refer to V1000 Technical Manual for details.
L3-02	Stall Prevention Level during Acceleration	Used when L3-01 = 1 or 2. 100% is equal to the drive rated current. Decrease the set value if stalling or excessive current occurs with default setting.
L3-03	Stall Prevention Limit during Acceleration	Refer to V1000 Technical Manual for details.
L3-04	Stall Prevention Selection during Deceleration	0: Disabled 1: General Purpose 2: Intelligent 3: Stall Prevention with Braking Resistor 4: Overexcitation Deceleration
L3-05	Stall Prevention Selection during Run	0: Disabled 1: Decel Time 1 2: Decel Time 2
L3-06	Stall Prevention Level during Run	Enabled when L3-05 is set to "1" or "2". 100% is equal to the drive rated current.
L3-11	OV Suppression Function Selection	Refer to V1000 Technical Manual for details.

## 7.1 Parameter Table

No.	Name	Description
L3-17	Overvoltage Suppression and Stall Prevention Desired DC Bus Voltage	Refer to V1000 Technical Manual for details.
L3-20	Main Power Circuit Voltage Adjustment Gain	Refer to V1000 Technical Manual for details.
L3-21	Accel/Decel Rate Calculation Gain	Refer to V1000 Technical Manual for details.
L3-22	Deceleration Time at Stall Prevention during Acceleration	Refer to V1000 Technical Manual for details.
L3-23	Automatic Reduction Selection for Stall Prevention during Run	0: Sets the stall prevention level throughout the entire frequency range to the value in parameter L3-06. 1: Automatically lowers the stall prevention level in the constant output range. The lower limit value is 40% of L3-06.
L3-24	Motor Acceleration Time for Inertia Calculations	Refer to V1000 Technical Manual for details.
L3-25	Load Inertia Ratio	Refer to V1000 Technical Manual for details.
<b>L4: Frequency Detection</b> Use L4 parameters to configure frequency detection operation.		
L4-01	Speed Agreement Detection Level	These parameters configure the multi-function output (H2-□□ = 2, 3, 4, 5) settings “Fref/Fout Agree 1,” “Fref/Set Agree 1,” “Frequency Detection 1,” and “Frequency detection 2.”
L4-02	Speed Agreement Detection Width	
L4-03	Speed Agreement Detection Level (+/-)	
L4-04	Speed Agreement Detection Width (+/-)	
L4-05	Frequency Reference Loss Detection Selection	0: Stop - Drive will stop 1: Run at L4-06
L4-06	Frequency Reference at Reference Loss	Refer to V1000 Technical Manual for details.
L4-07	Frequency Detection Conditions	Refer to V1000 Technical Manual for details.
L4-08	Frequency Agreement Conditions Selection	Refer to V1000 Technical Manual for details.
<b>L5: Fault Reset</b> Use L5 parameters to configure Automatic Restart after fault.		
L5-01	Number of Auto Restart Attempts	Sets the counter for the number of times the drive attempts to restart when the following faults occur: gF, LF, oC, oV, PF, PUF, rH, rr, oL1, oL2, oL3, oL4, Uv1.
L5-02	Auto Restart Operation Selection	Refer to V1000 Technical Manual for details.
L5-04	Fault Reset Interval Time	Refer to V1000 Technical Manual for details.
L5-05	Fault Reset Operation Selection	Refer to V1000 Technical Manual for details.
<b>L6: Overtorque Detection</b> Use L6 parameters to configure overtorque detection.		

## 7.1 Parameter Table

No.	Name	Description
L6-01	Torque Detection Selection 1	0: Disabled 1: oL3 at Speed Agree - Alarm 2: oL3 at RUN - Alarm 3: oL3 at Speed Agree - Fault 5: UL3 at Speed Agree - Alarm 6: UL3 at RUN - Alarm 7: UL3 at Speed Agree - Fault 8: UL3 at RUN - Fault
L6-02	Torque Detection Level 1	Sets the overtorque/undertorque detection level.
L6-03	Torque Detection Time 1	Sets the length of time an overtorque/undertorque condition must exist before Torque Detection 1 is triggered.
L6-04	Torque Detection Selection 2	Refer to V1000 Technical Manual for details.
L6-05	Torque Detection Level 2	Refer to V1000 Technical Manual for details.
L6-06	Torque Detection Time 2	Refer to V1000 Technical Manual for details.
L6-08	Mechanical Weakening (OL5) Detection Operation	Refer to V1000 Technical Manual for details.
L6-09	Mechanical Weakening Detection Speed Level	Refer to V1000 Technical Manual for details.
L6-10	Mechanical Weakening Detection Time	Refer to V1000 Technical Manual for details.
L6-11	Mechanical Weakening Detection Start Time	Refer to V1000 Technical Manual for details.
<b>L7: Torque Limit</b> Use L7 parameters to configure the torque limit function.		
L7-01	Forward Torque Limit	Refer to V1000 Technical Manual for details.
L7-02	Reverse Torque Limit	
L7-03	Forward Regenerative Torque Limit	
L7-04	Reverse Regenerative Torque Limit	
L7-06	Torque Limit Integral Time Constant	Refer to V1000 Technical Manual for details.
L7-07	Torque Limit Control Method Selection during Accel/Decel	Refer to V1000 Technical Manual for details.
<b>L8: Hardware Protection</b> Use L8 parameters to configure hardware protection functions.		
L8-01	Internal Dynamic Braking Resistor Protection Selection (ERF type)	0: Resistor overheat protection disabled 1: Resistor overheat protection enabled
L8-02	Overheat Alarm Level	Refer to V1000 Technical Manual for details.
L8-03	Overheat Pre-Alarm Operation Selection	Refer to V1000 Technical Manual for details.
L8-05	Input Phase Loss Protection Selection	0: Disabled 1: Enabled

No.	Name	Description
L8-07	Output Phase Loss Protection	0: Disabled 1: Enabled (triggered by a single phase loss). 2: Enabled (triggered when two phases are lost).
L8-09	Output Ground Fault Detection Selection	Refer to V1000 Technical Manual for details.
L8-10	Heatsink Cooling Fan Operation Selection	0: Fan On-Run Mode 1: Fan always on
L8-11	Heatsink Cooling Fan Operation Delay Time	Refer to V1000 Technical Manual for details.
L8-12	Ambient Temperature Setting	Refer to V1000 Technical Manual for details.
L8-15	OL2 Characteristics Selection at Low Speeds	Refer to V1000 Technical Manual for details.
L8-18	Soft CLA Selection	Refer to V1000 Technical Manual for details.
L8-19	Frequency Reduction Rate during OH Pre-Alarm	Refer to V1000 Technical Manual for details.
L8-29	Current Unbalance Detection (LF2)	Refer to V1000 Technical Manual for details.
L8-35	Installation Method Selection	Refer to V1000 Technical Manual for details.
L8-38	Carrier Frequency Reduction	0: Disabled 1: Enabled below 6 Hz 2: Enabled for the whole speed range
L8-40	Carrier Frequency Reduction Time	Refer to V1000 Technical Manual for details.
L8-41	High Current Alarm Selection	Refer to V1000 Technical Manual for details.
<b>n1: Hunting Prevention</b>		
Use n1 parameters to configure hunting prevention operation.		
n1-01	Hunting Prevention Selection	Refer to V1000 Technical Manual for details.
n1-02	Hunting Prevention Gain Setting	Refer to V1000 Technical Manual for details.
n1-03	Hunting Prevention Time Constant	Refer to V1000 Technical Manual for details.
n1-05	Hunting Prevention Gain while in Reverse	Refer to V1000 Technical Manual for details.
<b>n2: Speed Feedback Detection Control Function</b>		
Use n2 parameters to configure the Speed Feedback Detection Control function operation.		
n2-01	Speed Feedback Detection Control (AFR) Gain	Refer to V1000 Technical Manual for details.
n2-02	Speed Feedback Detection Control (AFR) Time Constant	Refer to V1000 Technical Manual for details.
n2-03	Speed Feedback Detection Control (AFR) Time Constant 2	Refer to V1000 Technical Manual for details.
<b>n3: High-Slip Braking</b>		
Use n3 parameters to configure the high-slip braking function.		

## 7.1 Parameter Table

No.	Name	Description
n3-01	High-Slip Braking Deceleration Frequency Width	Refer to V1000 Technical Manual for details.
n3-02	High-Slip Braking Current Limit	Refer to V1000 Technical Manual for details.
n3-03	High-Slip Braking Dwell Time at Stop	Refer to V1000 Technical Manual for details.
n3-04	High-Slip Braking Overload Time	Refer to V1000 Technical Manual for details.
n3-13	Overexcitation Deceleration Gain	Refer to V1000 Technical Manual for details.
n3-21	High-Slip Suppression Current Level	Refer to V1000 Technical Manual for details.
n3-23	Overexcitation Operation Selection	Refer to V1000 Technical Manual for details.
<b>n6: Online Tuning of Resistance between Motor Lines</b> Use n6 parameters to adjust the motor line-to-line resistance while the drive is online.		
n6-01	Line-to-Line Motor Resistance Online Tuning	Refer to V1000 Technical Manual for details.
<b>n8: Permanent Magnet (PM) Motor Control</b> Use n8 parameters to control the PM motor control.		
n8-45	Speed Feedback Detection Control Gain	Refer to V1000 Technical Manual for details.
n8-47	Pull-In Current Compensation Time Constant	Refer to V1000 Technical Manual for details.
n8-48	Pull-In Current	Refer to V1000 Technical Manual for details.
n8-49	Load Current	Refer to V1000 Technical Manual for details.
n8-51	Acceleration Pull-In Current	Refer to V1000 Technical Manual for details.
n8-54	Voltage Error Compensation Time Constant	Refer to V1000 Technical Manual for details.
n8-55	Load Inertia	Refer to V1000 Technical Manual for details.
n8-62	Output Voltage Limit	Refer to V1000 Technical Manual for details.
n8-65	Speed Feedback Detection Control Gain during ov Suppression	Refer to V1000 Technical Manual for details. <b>NOTE:</b> Available in software versions PRG:1011 and higher.
<b>o1: Display Settings</b> Use o1 parameters to configure the digital operator display.		
o1-01	Drive Mode Unit Monitor Selection	Refer to V1000 Technical Manual for details.
o1-02	User Monitor Selection After Power Up	Refer to V1000 Technical Manual for details.
o1-03	Digital Operator Display Selection	0: Hz 1: % (100% = E1-04) 2: r/min (enter the number of motor poles into E2-04/E4-04/E5-04) 3: User defined by parameters o1-10 and o1-11

No.	Name	Description
o1-10	Frequency Reference Setting and User-Set Display	Refer to V1000 Technical Manual for details.
o1-11	Frequency Reference Setting / Decimal Display	
<b>o2: Multi-Function Selections</b> Use o2 parameters to configure LED digital operator key functions.		
o2-01	LO/RE Key Function Selection	Refer to V1000 Technical Manual for details.
o2-02	STOP Key Function Selection	Enables/Disables the operator panel STOP key when the drive is operated from external sources (not operator). 0: Disabled. 1: Enabled
o2-03	User Parameter Default Value	Refer to V1000 Technical Manual for details.
o2-04	Drive Model Selection	Refer to V1000 Technical Manual for details.
o2-05	Frequency Reference Setting Method Selection	0: Data/Enter key must be pressed to enter a frequency reference. 1: Data/Enter key is not required. The frequency reference is adjusted by the “up” and “down” arrow keys.
o2-06	Operation Selection when Digital Operator is Disconnected	0: The drive will continue operation 1: The drive will trigger a fault (oPr) and the motor will coast to stop
o2-07	Motor Direction at Power Up when Using Operator	Refer to V1000 Technical Manual for details.
<b>o4: Maintenance Period</b> Use o4 parameters to perform maintenance.		
o4-01	Accumulated Operation Time Setting	Sets the starting value for the cumulative operation time of the drive in units of 10 h.
o4-02	Accumulated Operation Time Selection	0: Logs power-on time 1: Logs operation time when the drive output is active (output operation time).
o4-03	Cooling Fan Operation Time Setting	Refer to V1000 Technical Manual for details.
o4-05	Capacitor Maintenance Setting	Refer to V1000 Technical Manual for details.
o4-07	Soft Charge Bypass Relay Maintenance Setting	Refer to V1000 Technical Manual for details.
o4-09	IGBT Maintenance Setting	Refer to V1000 Technical Manual for details.
o4-11	U2, U3 Initialize Selection	0: Saves the fault monitor data. 1: Resets the fault monitor data to 0.
o4-12	kWh Monitor Initialize Selection	Refer to V1000 Technical Manual for details.
o4-13	Number of Run commands Initialize selection	Refer to V1000 Technical Manual for details.
q1-01 to q6-07	DWEZ Parameters	Reserved for DriveWorksEZ.
r1-01 to r1-40	DWEZ Connection Parameters 1 to 20 (upper/lower)	Please refer to the Help file included with the DriveWorksEZ software package for details.

## 7.1 Parameter Table

No.	Name	Description
T1-00	Motor Selection 1/2	1: 1st Motor - E1 to E2 2: 2nd Motor - E3 to E4 (this selection is not displayed if motor 2 has not been selected)
T1-01	Auto-Tuning Mode Selection	0: Rotational Auto-Tuning 2: Stationary Auto-Tuning 3: Rotational Auto-Tuning for V/f control
T1-02	Motor Rated Power	Sets the motor rated power in kilowatts (kW).
T1-03	Motor Rated Voltage	Sets the motor rated voltage in volts (V).
T1-04	Motor Rated Current	Sets the motor rated current in amperes (A).
T1-05	Motor Base Frequency	Sets the base frequency of the motor in Hertz (Hz).
T1-06	Number of Motor Poles	Sets the number of motor poles.
T1-07	Motor Base Speed	Sets the base speed of the motor in revolutions per minute r/min (RPM).
T1-11	Motor Iron Loss	Provides the iron loss for determining the Energy Saving coefficient.
<b>U1: Operation Status Monitors</b> Use U1 monitors to display the operation status of the drive.		
U1-01	Frequency Reference	Monitors the frequency
U1-02	Output Frequency	Displays the output frequency.
U1-03	Output Current	Displays the output current.
U1-04	Control Mode	Refer to V1000 Technical Manual for details.
U1-05	Motor Speed	Displays the motor speed feedback. Display units are determined by o1-03.
U1-06	Output Voltage Reference	Displays the output voltage.
U1-07	DC Bus Voltage	Displays the DC bus voltage.
U1-08	Output Power	Displays the output voltage (this value is determined internally).
U1-09	Torque Reference	Monitor of internal torque reference value for Open Loop Vector (OLV) control
U1-10	Input Terminal Status	Displays the input terminal status.
U1-11	Output Terminal Status	Displays the output terminal status.
U1-12	Drive Status	Verifies the drive operation status.
U1-13	Terminal A1 Input Voltage	Displays the analog input A1 input level. 100% when the input is 10 V.
U1-14	Terminal A2 Input Voltage	Displays the analog input A2 input level. 100% when the input is 10 V / 20 mA.
U1-16	Output Frequency after Soft Start	Displays the output frequency.
U1-18	OPE Fault Parameter	Displays the parameter number for oPE□□ or Err (operator error) where the error occurred.
U1-19	MEMOBUS/Modbus Error Code	Refer to V1000 Technical Manual for details.
U1-24	Input Pulse Monitor	Displays the Pulse Train input RP frequency.
U1-25	Software No. (Flash)	Yaskawa Flash ID

No.	Name	Description
U1-26	Software No. (ROM)	Yaskawa ROM ID
U1-27	Message ID (Operator)	Refer to V1000 Technical Manual for details.
U1-28	Message ID (Drive)	Refer to V1000 Technical Manual for details.
<b>U2: Fault Trace</b> Use U2 monitor parameters to view fault trace data.		
U2-01	Current Fault	Display of the current fault.
U2-02	Previous Fault	Display of the previous fault.
U2-03	Frequency Reference at Previous Fault	Displays the frequency reference at the previous fault.
U2-04	Output Frequency at Previous Fault	Displays the output frequency at the previous fault.
U2-05	Output Current at Previous Fault	Displays the output current at the previous fault.
U2-06	Motor Speed at Previous Fault	Displays the motor speed at the previous fault.
U2-07	Output Voltage at Previous Fault	Displays the output voltage at the previous fault.
U2-08	DC Bus Voltage at Previous Fault	Displays the DC bus voltage at the previous fault.
U2-09	Output Power at Previous Fault	Displays the output power at the previous fault.
U2-10	Torque Reference at Previous Fault	Displays the torque reference at the previous fault.
U2-11	Input Terminal Status at Previous Fault	Displays the input terminal status at the previous fault. Displayed as in U1-10.
U2-12	Output Terminal Status at Previous Fault	Displays the output status at the previous fault.
U2-13	Drive Operation Status at Previous Fault	Displays the operation status of drive at the previous fault.
U2-14	Cumulative Operation Time at Previous Fault	Displays the cumulative operation time at the previous fault.
U2-15	Soft Starter Speed Reference at Previous Fault	Displays speed reference for soft starter at the previous fault.
U2-16	Motor q-Axis Current at Previous Fault	Displays q-axis current for the motor at the previous fault.
U2-17	Motor d-Axis Current at Previous Fault	Displays d-axis current for the motor at the previous fault.
<b>U3: Fault History</b> Use U3 parameters to display fault data.		
U3-01	Most Recent Fault	Displays the most recent fault.
U3-02	2nd Most Recent Fault	Displays the second most recent fault.
U3-03	3rd Most Recent Fault	Displays the third most recent fault.
U3-04	4th Most Recent Fault	Displays the fourth most recent fault.
U3-05	5th Most Recent Fault	Displays the fifth most recent fault.

## 7.1 Parameter Table

No.	Name	Description
U3-06	6th Most Recent Fault	Displays the sixth most recent fault.
U3-07	7th Most Recent Fault	Displays the seventh most recent fault.
U3-08	8th Most Recent Fault	Displays the eighth most recent fault.
U3-09	9th Most Recent Fault	Displays the ninth most recent fault.
U3-10	10th Most Recent Fault	Displays the tenth most recent fault.
U3-11	Cumulative Operation Time at Most Recent Fault	Displays the cumulative operation time at the most recent fault.
U3-12	Cumulative Operation Time at 2nd Most Recent Fault	Displays the cumulative operation time at the second most recent fault.
U3-13	Cumulative Operation Time at 3rd Most Recent Fault	Displays the cumulative operation time at the third most recent fault.
U3-14	Cumulative Operation Time at 4th Most Recent Fault	Displays the cumulative operation time at the fourth most recent fault.
U3-15	Cumulative Operation Time at 5th Most Recent Fault	Displays the cumulative operation time at the fifth most recent fault.
U3-16	Cumulative Operation Time at 6th Most Recent Fault	Displays the cumulative operation time at the sixth most recent fault.
U3-17	Cumulative Operation Time at 7th Most Recent Fault	Displays the cumulative operation time at the seventh most recent fault.
U3-18	Cumulative Operation Time at 8th Most Recent Fault	Displays the cumulative operation time at the eighth most recent fault.
U3-19	Cumulative Operation Time at 9th Most Recent Fault	Displays the cumulative operation time at the ninth most recent fault.
U3-20	Cumulative Operation Time at 10th Most Recent Fault	Displays the cumulative operation time at the tenth most recent fault.
<b>U4: Maintenance Monitors</b>		
Use U4 parameters to display drive maintenance information.		
U4-01	Accumulated Operation Time	Refer to V1000 Technical Manual for details.
U4-02	Number of Run Commands	Refer to V1000 Technical Manual for details.
U4-03	Cooling Fan Operation Time	Refer to V1000 Technical Manual for details.
U4-05	Capacitor Maintenance	Refer to V1000 Technical Manual for details.
U4-06	Soft Charge Bypass Relay Maintenance	Refer to V1000 Technical Manual for details.
U4-07	IGBT Maintenance	Refer to V1000 Technical Manual for details.
U4-08	Heatsink Temperature	Refer to V1000 Technical Manual for details. <b>NOTE:</b> Available in software versions PRG:1011 and higher.
U4-09	LED Check	Refer to V1000 Technical Manual for details.
U4-10	kWH, Lower 4 Digits	Monitors the drive output power.
U4-11	kWH, Upper 5 Digits	
U4-13	Peak Hold Current	Displays the peak hold current during run.

No.	Name	Description
U4-14	Peak Hold Output Frequency	Refer to V1000 Technical Manual for details.
U4-16	Motor Overload Estimate (OL1)	100% = OL1 detection level
U4-18	Frequency Reference Source Selection	Refer to V1000 Technical Manual for details.
U4-19	Frequency Reference from MEMOBUS/Modbus Comm.	Refer to V1000 Technical Manual for details.
U4-20	Option Frequency Reference	Refer to V1000 Technical Manual for details.
U4-21	Run Command Source Selection	Refer to V1000 Technical Manual for details.
U4-22	MEMOBUS/Modbus Communications Reference	Refer to V1000 Technical Manual for details.
U4-23	Option Card Reference	Refer to V1000 Technical Manual for details.
<b>U5: PID Monitor</b> Use U5 parameters to view application-specific settings.		
U5-01	PID Feedback	Displays the PID feedback value.
U5-02	PID Input	Refer to V1000 Technical Manual for details.
U5-03	PID Output	Displays PID control output.
U5-04	PID Setpoint	Displays the PID setpoint.
U5-05	PID differential feedback	Refer to V1000 Technical Manual for details.
U5-06	PID Adjusted Feedback	Refer to V1000 Technical Manual for details.
<b>U6: Control Monitor</b> Use U6 parameters to display drive control information.		
U6-01	Motor Secondary Current (Iq)	Refer to V1000 Technical Manual for details.
U6-02	Motor Excitation Current (Id)	Refer to V1000 Technical Manual for details.
U6-03	ASR Input	Refer to V1000 Technical Manual for details.
U6-04	ASR Output	Refer to V1000 Technical Manual for details.
U6-05	Output voltage reference (Vq)	Output voltage reference (Vq). (q-axis)
U6-06	Output Voltage Reference (Vd)	Output voltage reference (Vd). (d-axis)
U6-07	q-axis ACR Output	Refer to V1000 Technical Manual for details.
U6-08	d-Axis ACR Output	Refer to V1000 Technical Manual for details.
U6-20	Frequency Reference Bias (Up/Down 2)	Refer to V1000 Technical Manual for details.
U6-21	Offset Frequency	Refer to V1000 Technical Manual for details.

- Note:**
1. Cycle power to the drive to enable MEMOBUS/Modbus settings.
  2. If using Open Loop Vector Control (A1-02 = 2), Auto-Tuning will need to be performed again after the drive is initialized. *Refer to Auto-Tuning on page 109* for details.

**This Page Intentionally Blank**



## Standards Compliance

---

This chapter explains the guidelines and criteria for maintaining CE and UL standards.

<b>8.1</b>	<b>EUROPEAN STANDARDS.....</b>	<b>192</b>
<b>8.2</b>	<b>UL STANDARDS.....</b>	<b>200</b>
<b>8.3</b>	<b>SAFE DISABLE INPUT PRECAUTIONS.....</b>	<b>206</b>
<b>8.4</b>	<b>V1000 - ORIENTAÇÃO BÁSICA .....</b>	<b>208</b>

# 8.1 European Standards



Figure 8.1 CE Mark

The CE mark indicates compliance with European safety and environmental regulations and is required for engaging in business and commerce in Europe.

European standards include the Machinery Directive for machine manufacturers, the Low Voltage Directive for electronics manufacturers and the EMC guidelines for controlling noise.

This drive displays the CE mark based on the EMC guidelines and the Low Voltage Directive.

- **EMC Guidelines:** Devices used in combination with this drive must also be CE certified and display the CE mark. When using drives displaying the CE mark in combination with other devices, it is ultimately the responsibility of the user to ensure compliance with CE standards. After setting up the device, verify that conditions meet European standards.
- **Low Voltage Directive:** 73/23/EEC, 93/68/EEC

---

### ◆ CE Low Voltage Directive Compliance

This drive has been tested according to European standard EN50178, and it fully complies with the Low Voltage Directive.

To comply with the Low Voltage Directive, be sure to meet the following conditions when combining this drive with other devices:

#### ■ Area of Use

Do not use drives in areas with pollution higher than severity 2 and overvoltage category 3 in accordance with IEC664.

#### ■ Installing Fuses on the Input Side

Always install input fuses. Select fuses according to [Table 8.1](#).

**Table 8.1 Recommended Input Fuse Selection**

Drive Model CIMR-V□	Fuse Type	Fuse	Fuse Ampere Rating
<b>200 V Class Single-Phase Drives</b>			
BA0001	Time Delay Class RK5 Fuses 600 Vac, 200 kAIR	TRS5R	5
BA0002		TRS10R	10
BA0003		TRS20R	20
BA0006		TRS35R	35
BA0010		TRS50R	50
BA0012		TRS60R	60
BA0018	Non-Time Delay Class T Fuses 600 Vac, 200 kAIR	A6T80	80
<b>200 V Class Three-Phase Drives</b>			
2A0001	Time Delay Class RK5 Fuses 600 Vac, 200 kAIR	TRS5R	5
2A0002		TRS5R	5
2A0004		TRS10R	10
2A0006		TRS15R	15
2A0010		TRS25R	25
2A0012		TRS35R	35
2A0020		TRS60R	60
2A0030	Non-Time Delay Class T Fuses 600 Vac, 200 kAIR	A6T70	70
2A0040		A6T100	100
2A0056		A6T150	150
2A0069		A6T200	200
<b>400 V Class Three-Phase Drives</b>			
4A0001	Time Delay Class RK5 Fuses 600 Vac, 200 kAIR	TRS2.5R	2.5
4A0002		TRS5R	5
4A0004		TRS10R	10
4A0005		TRS20R	20
4A0007		TRS20R	20
4A0009		TRS20R	20
4A0011		TRS30R	30

## 8.1 European Standards

---

Drive Model CIMR-V□	Fuse Type	Fuse	Fuse Ampere Rating
4A0018	Non-Time Delay Class T Fuses 600 Vac, 200 kAIR	A6T50	50
4A0023		A6T60	60
4A0031		A6T70	70
4A0038		A6T80	80

### ■ Guarding Against Harmful Materials

When installing IP20/Open-Chassis drives, use an enclosure that prevents foreign material from entering the drive from above or below.

### ■ Grounding

The drive is designed to be used in T-N (grounded neutral point) networks. If installing the drive in other types of grounded systems, contact your dealer or Yaskawa for instructions.

---

### ◆ EMC Guidelines Compliance

This drive is tested according to European standards EN61800-3 and it complies with the EMC guidelines.

### ■ EMC Filter Installation

The following conditions must be met to ensure continued compliance with guidelines. *Refer to EMC Filters on page 197* for EMC filter selection.

#### Installation Method

Verify the following installation conditions to ensure that other devices and machinery used in combination with this drive also comply with EMC guidelines.

1. Install an EMC noise filter to the input side specified by Yaskawa for compliance with European standards.
2. Place the drive and EMC noise filter in the same enclosure.
3. Use braided shield cable for the drive and motor wiring or run the wiring through a metal conduit.
4. Keep wiring as short as possible. Ground the shield on both the drive side and the motor side.
5. Ground the largest possible surface area of the shield to the metal conduit when using braided shield cable. Yaskawa recommends using a cable clamp.

### Three-Phase 200 V / 400 V Class

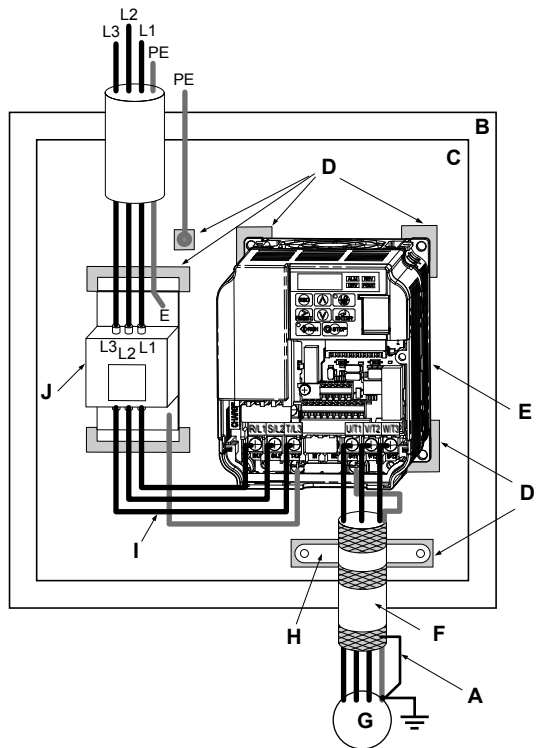

- |  |   |
|--|---|
| A – Ground the cable shield                            | F – Motor cable (braided shield cable, max. 20 m) |
| B – Enclosure panel                                    | G – Motor   |
| C – Metal plate  | H – Cable clamp                                   |
| D – Grounding surface<br>(remove any paint or sealant) | I – Max. distance between drive and noise filter  |
| E – Drive  | J – EMC noise filter                              |

**Figure 8.2 EMC Filter and Drive Installation for CE Compliance  
(Three-Phase 200 V / 400 V Class)**

## 8.1 European Standards

### Single-Phase 200 V Class

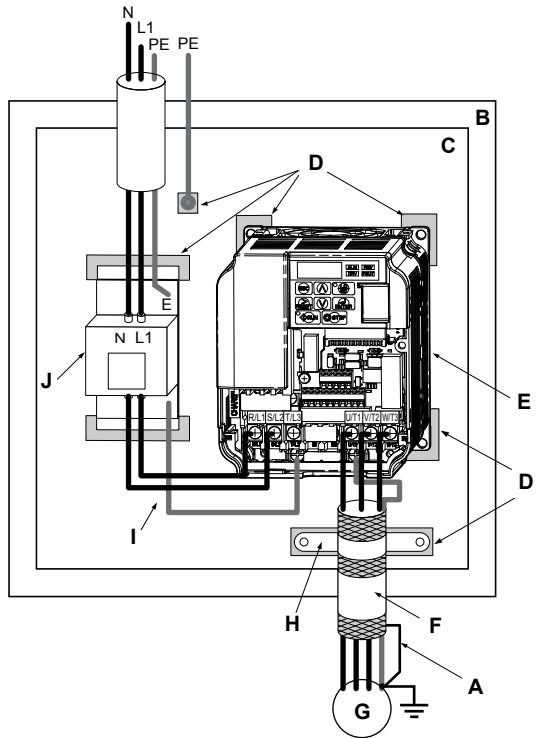

- |   |   |
|---|---|
| A – Ground the cable shield                         | F – Motor cable (braided shield cable, max. 20 m) |
| B – Enclosure panel                                 | G – Motor   |
| C – Metal plate                                     | H – Cable clamp                                   |
| D – Grounding surface (remove any paint or sealant) | I – Wiring distance as short as possible          |
| E – Drive   | J – EMC noise filter                              |

Figure 8.3 EMC Filter and Drive Installation for CE Compliance (Single-Phase 200 V Class)

## ■ EMC Filters

The drive should be installed with the EMC filters listed below in order to comply with the EN 61800-3, category C1 requirements.

**Note:** If the Safe Disable function of the drive is part of the safety concept of a machine or installation and used for a safe stop according to EN60204-1, stop category 0, use only filters manufactured by Schaffner as listed below.

**Table 8.2 EN 61800-3 Category C1 Filters**

Drive CIMR-V□	Filter Data (Manufacturer: Schaffner)						
	Type	Rated Current (A)	Weight (lb)	Dimensions [W x L x H] (in)	Mounting Dimensions [Y x X] (mm)	Drive Mounting Screw A	Filter Mounting Screw
<b>200 V Single-Phase Units</b>							
BA0001	FS23638-10-07	10	0.97	2.8 x 6.7 x 1.8	2.0 x 6.1	M4	M5
BA0002	FS23638-10-07	10	0.97	2.8 x 6.7 x 1.8	2.0 x 6.1	M4	M5
BA0003	FS23638-10-07	10	0.97	2.8 x 6.7 x 1.8	2.0 x 6.1	M4	M5
BA0006	FS23638-20-07	20	1.65	4.4 x 6.7 x 2.0	3.6 x 6.1	M4	M5
BA0010	FS23638-20-07	20	1.65	4.4 x 6.7 x 2.0	3.6 x 6.1	M4	M5
BA0012	FS23638-30-07	30	2.42	5.7 x 6.9 x 2.0	4.7 x 6.3	M4	M5
BA0018	FS23638-40-07	40	2.87	6.9 x 6.9 x 2.0	5.9 x 6.3	M4	M5
<b>200 V Three-Phase Units</b>							
2A0001	FS23637-8-07	7.3	0.88	2.8 x 6.7 x 1.6	2.0 x 6.1	M4	M5
2A0002	FS23637-8-07	7.3	0.88	2.8 x 6.7 x 1.6	2.0 x 6.1	M4	M5
2A0004	FS23637-8-07	7.3	0.88	2.8 x 6.7 x 1.6	2.0 x 6.1	M4	M5
2A0006	FS23637-8-07	7.3	0.88	2.8 x 6.7 x 1.6	2.0 x 6.1	M4	M5
2A0010	FS23637-14-07	14	1.28	4.4 x 6.7 x 1.8	3.6 x 6.1	M4	M5
2A0012	FS23637-14-07	14	1.28	4.4 x 6.7 x 1.8	3.6 x 6.1	M4	M5
2A0020	FS23637-24-07	24	1.98	5.7 x 6.9 x 2.0	4.7 x 6.1	M4	M5
2A0030	FS23637-52-07	52	4.41	5.4 x 12.0 x 2.2	3.9 x 11.4	M5	M5
2A0040	FS23637-52-07	52	4.41	5.4 x 12.0 x 2.2	3.9 x 11.4	M5	M5
2A0056	FS23637-68-07	68	5.73	6.9 x 13.4 x 2.6	5.1 x 12.8	M5	M6
2A0069	FS23637-80-07	80	6.83	8.3 x 15.5 x 2.6	6.6 x 14.9	M6	M8
<b>400 V Three-Phase Units</b>							
4A0001	FS23639-5-07	5	1.10	4.4 x 6.7 x 1.8	3.6 x 6.1	M4	M5
4A0002	FS23639-5-07	5	1.10	4.4 x 6.7 x 1.8	3.6 x 6.1	M4	M5
4A0004	FS23639-5-07	5	1.10	4.4 x 6.7 x 1.8	3.6 x 6.1	M4	M5

## 8.1 European Standards

Drive CIMR-V□	Filter Data (Manufacturer: Schaffner)						
	Type	Rated Current (A)	Weight (lb)	Dimensions [W x L x H] (in)	Mounting Dimensions [Y x X] (mm)	Drive Mounting Screw A	Filter Mounting Screw
4A0005	FS23639-10-07	10	1.54	4.4 x 6.7 x 1.8	3.6 x 6.1	M4	M5
4A0007	FS23639-10-07	10	1.54	4.4 x 6.7 x 1.8	3.6 x 6.1	M4	M5
4A0009	FS23639-10-07	10	1.54	4.4 x 6.7 x 1.8	3.6 x 6.1	M4	M5
4A0011	FS23639-15-07	15	1.98	5.7 x 6.9 x 2.0	4.7 x 6.3	M4	M5
4A0018	FS23639-30-07	30	4.0	5.4 x 12.0 x 2.2	3.9 x 11.4	M5	M5
4A0023	FS23639-30-07	30	4.0	5.4 x 12.0 x 2.2	3.9 x 11.4	M5	M5
4A0031	FS23639-50-07	50	6.0	6.9 x 13.4 x 2.6	5.1 x 12.8	M5	M6
4A0038	FS23639-50-07	50	6.0	6.9 x 13.4 x 2.6	5.1 x 12.8	M5	M6

**Note:** EMC filters for models CIMR-V□2A0030 through 0069 are in compliance with IEC61800-3, Category 2. All other models comply with Category 1.

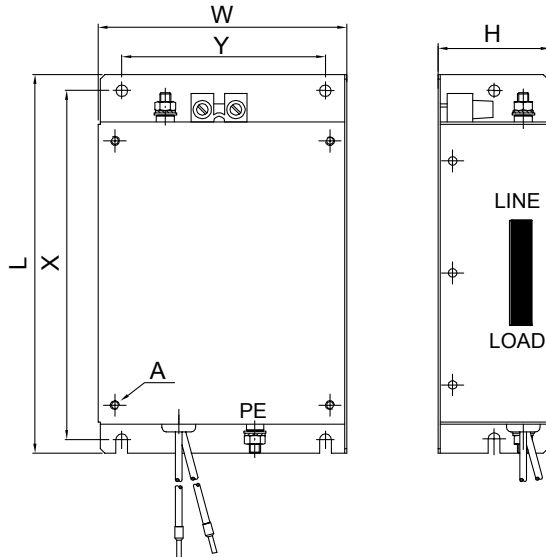

**Figure 8.4 EMC Filter Dimensions**

## ■ DC Reactors for EN 61000-3-2 Compliance

Table 8.3 DC Reactors for Harmonics Reduction

Drive Model CIMR-V□	DC Reactor	
	Model	Rating
<b>200V Three-Phase Units</b>		
2A0004	UZDA-B	5.4 A 8 mH
2A0006		
<b>400 V Three-Phase Units</b>		
4A0002	UZDA-B	3.2 A 28 mH
4A0004		

**Note:** Models not listed in the above table do not require a DC reactor for EMC compliance.

# 8.2 UL Standards

The UL/cUL mark applies to products in the United States and Canada indicates that UL has performed product testing and evaluation and determined that their stringent standards for product safety have been met. For a product to receive UL certification, all components inside that product must also receive UL certification.



Figure 8.5 UL/cUL Mark

### ◆ UL Standards Compliance

This drive is tested in accordance with UL standard UL508C and complies with UL requirements. The following conditions must be met to maintain compliance when using this drive in combination with other equipment:

#### ■ Installation Area

Do not install the drive to an area greater than pollution severity 2 (UL standard).

#### ■ Main Circuit Terminal Wiring

Yaskawa recommends using UL-listed copper wires (rated at 75 °C) and closed-loop connectors or CSA-certified ring connectors sized for the selected wire gauge to maintain proper clearances when wiring the drive. Use the correct crimp tool to install connectors per manufacturer recommendation. [Table 8.4](#) lists a suitable closed-loop connector manufactured by JST Corporation.

Table 8.4 Closed-Loop Crimp Terminal Size (JIS C 2805) (same for 200 V and 400 V)

Wire Gauge mm <sup>2</sup> (AWG)	Terminal Screws	Crimp Terminal Model Numbers	Tightening Torque N m (lb to in.)
0.75 (18)	M3.5	R1.25-3.5	0.8 to 1.0 (7.1 to 8.9)
	M4	R1.25-4	1.2 to 1.5 (10.6 to 13.3)
1.25 (16)	M3.5	R1.25-3.5	0.8 to 1.0 (7.1 to 8.9)
	M4	R1.25-4	1.2 to 1.5 (10.6 to 13.3)

Wire Gauge mm <sup>2</sup> (AWG)	Terminal Screws	Crimp Terminal Model Numbers	Tightening Torque N m (lb to in.)
2 (14)	M3.5	R2-3.5	0.8 to 1.0 (7.1 to 8.9)
	M4	R2-4	1.2 to 1.5 (10.6 to 13.3)
	M5	R2-5	2.0 to 2.5 (17.7 to 22.1)
	M6	R2-6	4.0 to 5.0 (35.4 to 44.3)
3.5/5.5 (12/10)	M4	R5.5-4	1.2 to 1.5 (10.6 to 13.3)
	M5	R5.5-5	2.0 to 2.5 (17.7 to 22.1)
	M6	R5.5-6	4.0 to 5.0 (35.4 to 44.3)
	M8	R5.5-8	9.0 to 11.0 (79.7 to 97.4)
8 (8)	M4	8-4	1.2 to 1.5 (10.6 to 13.3)
	M5	R8-5	2.0 to 2.5 (17.7 to 22.1)
	M6	R8-6	4.0 to 5.0 (35.4 to 44.3)
	M8	R8-8	9.0 to 11.0 (79.7 to 97.4)
14 (6)	M4	14-4 <->	1.2 to 1.5 (10.6 to 13.3)
	M5	R14-5	2.0 to 2.5 (17.7 to 22.1)
	M6	R14-6	4.0 to 5.0 (35.4 to 44.3)
	M8	R14-8	9.0 to 11.0 (79.7 to 97.4)
22 (4)	M6	R22-6	4.0 to 5.0 (35.4 to 44.3)
	M8	R22-8	9.0 to 11.0 (79.7 to 97.4)
30/38 (3/2)	M8	R38-8	9.0 to 11.0 (79.7 to 97.4)

<1> Use the specified crimp terminals (Model 14–NK4) when using CIMR-V□2A0030, V□2A0040, and V□4A0023 with 14 mm<sup>2</sup> (6 AWG).

**Note:** Use crimp insulated terminals or insulated shrink tubing for wiring connections. Wires should have a continuous maximum allowable temperature of 75 °C 600 Vac UL-approved vinyl-sheathed insulation.

**Table 8.5 Recommended Input Fuse Selection**

Drive Model CIMR-V□	Fuse Type	Fuse	Fuse Ampere Rating
<b>200 V Class Single-Phase Drives</b>			
BA0001	Time Delay Class RK5 Fuses 600 Vac, 200 kAIR	TRSSR	5
BA0002		TRS10R	10
BA0003		TRS20R	20
BA0006		TRS35R	35
BA0010		TRS50R	50
BA0012		TRS60R	60

## 8.2 UL Standards

Drive Model CIMR- V□	Fuse Type	Fuse	Fuse Ampere Rating
BA0018	Non-Time Delay Class J Fuses 600 Vac, 200 kAIR	A6T100	100
<b>200 V Class Three-Phase Drives</b>			
2A0001	Time Delay Class RK5 Fuses 600 Vac, 200 kAIR	TRS5R	5
2A0002		TRS5R	5
2A0004		TRS10R	10
2A0006		TRS15R	15
2A0010		TRS25R	25
2A0012		TRS35R	35
2A0020		TRS60R	60
2A0030		Non-Time Delay Class J Fuses 600 Vac, 200 kAIR	A6T110
2A0040	A6T150		150
2A0056	A6T200		200
2A0069	A6T225		225
<b>400 V Class Three-Phase Drives</b>			
4A0001	Time Delay Class RK5 Fuses 600 Vac, 200 kAIR	TRS2.5R	2.5
4A0002		TRS5R	5
4A0004		TRS10R	10
4A0005		TRS20R	20
4A0007		TRS20R	20
4A0009		TRS20R	20
4A0011		TRS30R	30
4A0018	Non-Time Delay Class J Fuses 600 Vac, 200 kAIR	A6T60	60
4A0023		A6T70	70
4A0031		A6T110	110
4A0038		A6T125	125

### ■ Low Voltage Wiring for Control Circuit Terminals

Wire low voltage wires with NEC Class 1 circuit conductors. Refer to national state or local codes for wiring. Use a class 2 (UL regulations) power supply for the control circuit terminal when not using the internal control power supply of the drive.

Table 8.6 Control Circuit Terminal Power Supply

Input / Output	Terminal Signal	Power Supply Specifications
Multi-function photocoupler output	P1, P2, PC	Require class 2 power supply
Multi-function digital inputs	S1, S2, S3, S4, S5, S6, S7, SC	Use the internal power supply of the drive. Use class 2 for external power supply.
Multi-function analog inputs	A1, A2, AC	Use the internal power supply of the drive. Use class 2 for external power supply.
Pulse train input	RP	Use the internal LVLC power supply of the drive. Use class 2 for external power supply.
Pulse train output	MP	Use the internal LVLC power supply of the drive. Use class 2 for external power supply.

### ■ Drive Short-Circuit Rating

This drive has undergone the UL short-circuit test, which certifies that during a short circuit in the power supply the current flow will not rise above 30,000 amps maximum at 240 V for 200 V class drives and 480 V for 400 V class drives.

- The MCCB and breaker protection and fuse ratings shall be equal to or greater than the short-circuit tolerance of the power supply being used.
- Suitable for use on a circuit capable of delivering not more than 30,000 RMS symmetrical amperes for 240 V in 200 V class drives (up to 480 V for 400 V class drives) motor overload protection.

### ◆ Drive Motor Overload Protection

Set parameter E2-01 (motor rated current) to the appropriate value to enable motor overload protection. The internal motor overload protection is UL listed and in accordance with the NEC and CEC.

### ■ E2-01 Motor Rated Current

Setting Range: Model Dependent

Default Setting: Model Dependent

Parameter E2-01 (motor rated current) protects the motor if parameter L1-01 is not set to 0 (default is 1, standard induction motor protection enabled).

If Auto-Tuning has been performed successfully, the motor data that was entered in T1-04 is automatically written into parameter E2-01. If Auto-Tuning has not been performed, manually enter the correct motor rated current in parameter E2-01.

## 8.2 UL Standards

---

### ■ L1-01 Motor Overload Protection Selection

The drive has an electronic overload protection function (oL1) based on time, output current and output frequency, which protects the motor from overheating. The electronic thermal overload function is UL-recognized, so it does not require an external thermal overload relay for single motor operation.

This parameter selects the motor overload curve used according to the type of motor applied.

**Table 8.7 Overload Protection Settings**

Setting	Description
0	Disabled
1	Standard Fan-Cooled Motor (Default)
2	Drive Duty Motor with a Speed Range of 1:10
3	Vector Motor with a Speed Range of 1:100
4	Permanent Magnet Motor
6	Customized Motor (50 Hz)

Disable the electronic overload protection (L1-01 = 0: Disabled) and wire each motor with its own motor thermal overload when connecting the drive to more than one motor for simultaneous operation.

Enable the motor overload protection (L1-01 = “1”, “2”, or “3”) when connecting the drive to a single motor unless there is another means of preventing motor thermal overload. The electronic thermal overload function causes an oL1 fault, which shuts off the output of the drive and prevents additional overheating of the motor. The motor temperature is continually calculated as long as the drive is powered up.

### ■ L1-02 Motor Overload Protection Time

Setting Range: 0.1 to 5.0 Minutes

Factory Default: 1.0 Minutes

The L1-02 parameter sets the allowed operation time before the oL1 fault occurs when the drive is running at 60 Hz and 150% of the full load amp rating (E2-01) of the motor. Adjusting the value of L1-02 can shift the set of oL1 curves up the Y-axis of the diagram below but will not change the shape of the curves.

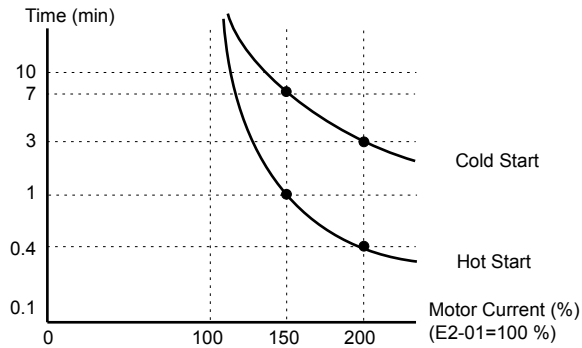

Figure 8.6 Motor Overload Protection Time

# 8.3 Safe Disable Input Precautions

### ◆ Safe Disable Function Description

The Safe Disable function can be utilized to perform a safe stop according to the EN60204-1, stop category 0 (Uncontrolled stop by power removal). It is designed to meet the requirements of the EN954-1, Safety Category 3 and EN61508, SIL2.

Removing the voltage from terminal H1 disables the drive output, i.e. the power supply to the motor is cut by stopping the switching of the output transistors in a safe way. “Hbb” is shown on the display. Safe Disable is applicable for induction and permanent magnet motors.

### ◆ Installation

If the Safe Disable function is utilized, the wire link between the terminals HC and H1 that is installed at shipment must be removed entirely.

Connect the drive to an EN954-1, Safety Category 3 interrupting device so that in case of a Safe Disable request the connection between the terminals HC and H1 is opened.

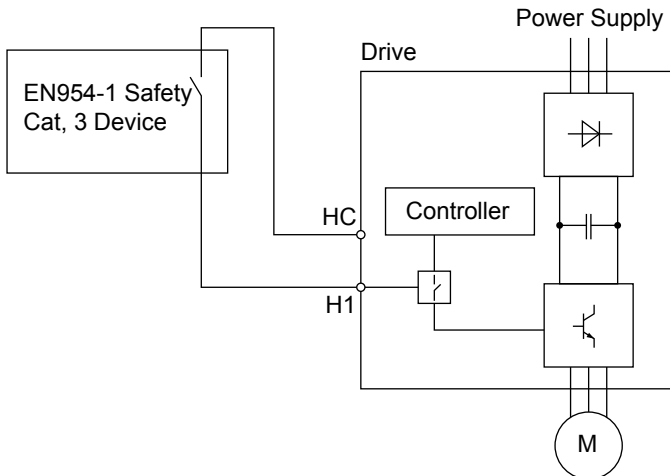

Figure 8.7 Safe Disable Wiring Example

### ■ Installation Precautions

- To ensure the Safe Disable function appropriately fulfills the safety requirements of the application, a thorough risk assessment for the safety system must be carried out.
- The drive must be installed in an enclosure with a protection degree of at least IP54 in order to maintain EN954-1, safety category 3 compliance.
- If the safety device and the drive are installed in separate cabinets, install the Safe Disable wires in a manner preventing short circuits.
- The Safe Disable function does not cut the power supply to the drive and does not provide electrical isolation. Before any installation or maintenance work is done, the power supply of the drive must be switched off.
- Consider the following when using PM motors: When the Safe Disable function is active, a failure in two of the drive power devices can occur and current will continue to flow through the motor winding. This failure will not produce torque in an induction motor, however, when occurring in a PM motor, torque will be produced and cause an alignment of the rotor magnets, which may cause the rotor to turn up to 180 degrees electrically. Ensure that this possible failure mode is not safety-critical for the application.
- The wiring distance for the Safe Disable inputs should not exceed 30 m.
- The time from opening the Safe Disable input until the drive output is switched off is less than 1 ms.
- When utilizing the Safe Disable function use the recommended EMC filters manufactured by Schaffner only.

# 8.4 V1000 - ORIENTAÇÃO BÁSICA

## PORTUGUÊS

---

### ◆ INVERSORES - V1000 TERMO DE GARANTIA

O manual do V1000 em português encontra-se no CD fornecido junto com o inversor

#### ■ Limites da Garantia

Os produtos fabricados pela YASKAWA são garantidos contra defeitos de fabricação pelo período de 12 (doze) meses da data de entrega do equipamento. A comprovação da aplicabilidade da garantia é feita através da nota fiscal de compra.

A garantia é FOB YASKAWA BRASIL não incluído custos de transporte e frete.

Os produtos com defeitos de fabricação serão reparados ou trocados por novos, a critério da YASKAWA, sem nenhum ônus ao cliente. Caberá a YASKAWA a definição da aplicação ou não da garantia. A obrigação da companhia restringe-se ao reparo ou troca de produtos defeituosos, não cobrindo em hipótese alguma custos adicionais decorrentes do não funcionamento dos equipamentos. A YASKAWA não assumirá responsabilidade por reparos em produtos e/ou equipamentos realizados por empresas não autorizadas. A vida dos produtos da companhia dependerá de seu uso e instalação corretas, dentro dos limites especificados. Produtos que sofrerem danos por instalação inadequada, por tensões impróprias e/ou interligações ou fiação incorretas, não serão cobertos pela garantia. A garantia Yaskawa não cobrirá danos causados por elementos naturais como raios, terremotos, avalanches, inundações e qualquer outro tipo de efeito causado pela natureza.

#### ■ Solicitação de Reparo em Garantia

Junto ao equipamento deverá ser enviado um relatório descrevendo o defeito e/ ou reclamação assim como descrição da aplicação e do motor utilizado. Solicite o formulário "solicitação de reparo em garantia" ao nosso departamento técnico.

#### ■ Garantia a Terceiros

A garantia é direito do primeiro comprador e deverá ser solicitada pelo mesmo.

---

### ◆ INVERSORES DE FREQUÊNCIA - V1000

#### ■ ORIENTAÇÃO BÁSICA

##### Instalação

Para o perfeito funcionamento e garantia de durabilidade, os inversores devem ser instalados em local abrigado e livre de altas temperaturas, chuva, umidade, óleo em suspensão, atmosferas salinas, exposição direta ao sol, gases ou líquidos corrosivos, poeira, partículas

metálicas em suspensão e vibrações excessivas. A temperatura ambiente máxima recomendada é de 40°C. Ao se instalar o inversor em locais fechados recomenda-se prever ventilação forçada adequada de forma a não permitir que a temperatura interna exceda a 50°C.

### Cuidados de Interligação

Conecte a alimentação nos terminais R/L1, S/L2 e T/L3 e o motor nos terminais U/T1, V/T2 e W/T3. Para operação com alimentação monofásica, conecte a alimentação aos terminais R/L1 e S/L2. Não utilize o T/L3.

### Para perfeito funcionamento do inversor siga as seguintes recomendações:

- O motor deve ser conectado aos terminais U, V e W.
- Nunca conecte a alimentação aos terminais de saída, isso irá danificar o inversor.
- Se a distância entre o motor e o inversor for longa, reduza a frequência da portadora, C6-02.
- A fiação de controle deve ter distância máxima de 50 m. Caso necessário distâncias maiores utilize relés para chaveamento dos comandos. Use cabos blindados instalados separados da fiação de força.
- Certifique-se que os terminais estejam apertados. Não conecte ou desconecte a fiação com o inversor energizado.
- Conecte o terminal de terra dos inversores a um ponto central, individualmente, evitando-se a formação de loops.
- Utilize cabos e terminais de pressão apropriados de forma a não existir mau contato na barra de terminais.

**Table 8.8 INDICAÇÃO DE FALHAS \***

Operador Digital	Descrição da Falha
bus	Erro de cartão de comunicação
BB	Supressão de Pulsos (Base Block Externo)
CE	Erro de comunicação Memobus/Modbus
CF / CPFxx	Falhas no cartão de controle
dEu	Desvio de velocidade
dWAL	Erro de saída programa DriveWorksEZ
dWFL	Falha DriveWorksEZ
EF	Erro de Sequenciamento: Comando Rodar Avante e Reverso Acionados Juntos.
EFx	Falha Externa
* Para informações mais detalhadas das falhas e alarmes, consultar o manual de programação e manutenção.	

## 8.4 V1000 - ORIENTAÇÃO BÁSICA

Operador Digital	Descrição da Falha
FAN	Falha no Ventilador
FbH/FbL	Realimentação PID excessiva ou Perda
GF	Fuga a Terra
LF / LF2	Perca de Fase na Saída/Desbalanceamento
oC	Sobrecorrente
oFAxx	Falha no cartão opcional
oH/oH1	Falha de Sobretemperatura no dissipador
oH3/oH4	Sobretemperatura: no motor (entrada PTC)
oL1	Sobrecarga do Motor
oL2	Sobrecarga do Inversor
oL3/4/7	Detecção Sobre torque
oPx	Erro de Programação
oS	Sobrevelocidade
oV	Sobretensão: Tensão Link CC Elevada
PF	Perca de Fase na Entrada
PGo	Encoder desconectado
rH	Sobretemperatura no Resistor de Frenagem
r r	Falha no transistor de frenagem
SER	Erro de Sequenciamento
Ser	Número de ligações excedido
uV	Subtensão: Tensão de Entrada Baixa
UV1	Subtensão
UV2	Subtensão no Controle
* Para informações mais detalhadas das falhas e alarmes, consultar o manual de programação e manutenção.	

## 8.4 V1000 - ORIENTAÇÃO BÁSICA

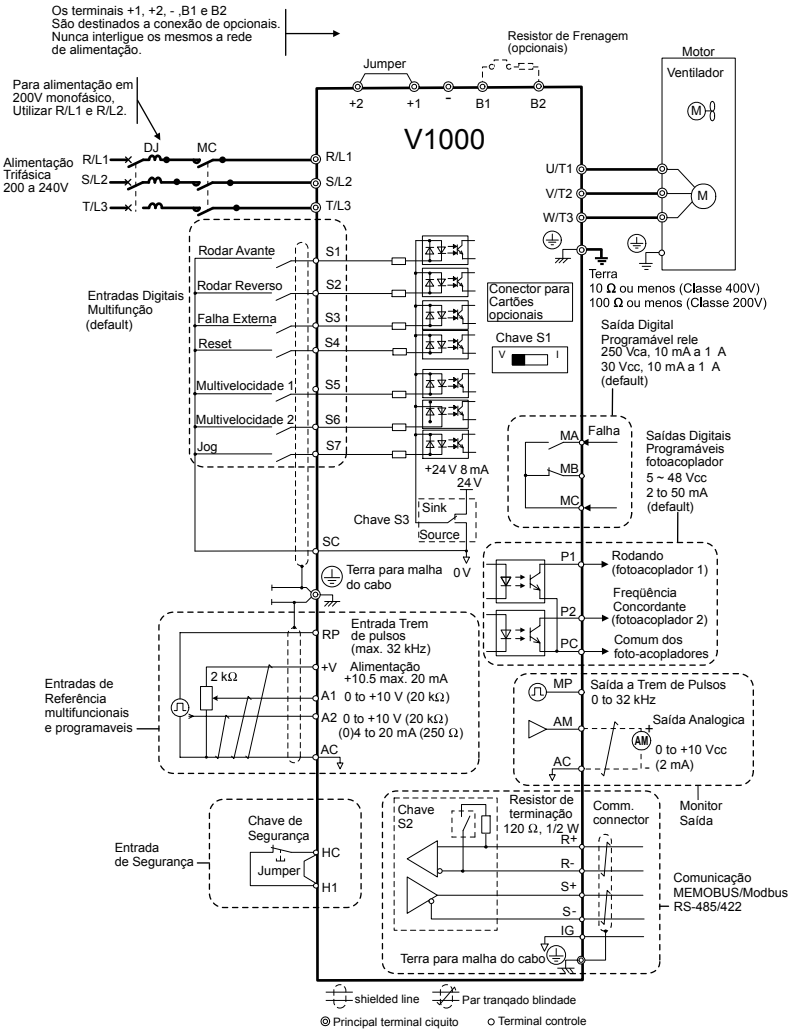

Figure 8.8 Diagrama de Interligações

## 8.4 V1000 - ORIENTAÇÃO BÁSICA

Entradas Digitais Multifunção:	Saídas Digitais Multifunção:	Entrada Analógica Multifunção:	Saída Analógica Multifunção:
S1: H1-01	MA: H2-01	A1: H3-02	AM: H4-02
S2: H1-02	P1 : H2-02	A2: H3-10	-
S3: H1-03	P2 : H2-03	-	-
S4: H1-04	-	-	-
S5: H1-05	-	-	-
S6: H1-06	-	-	-
S7: H1-07	-	-	-

<b>Yaskawa Eletrico do Brasil Ltda</b> Av. Fagundes Filho, 620 Bairro Saude Sao Paulo - SP	Fone: (0xx11) 3585-1100 Fax : (0xx11) 5581-8795 E-mail : yaskawa@yaskawa.com.br Site : www.yaskawa.com.br	Yaskawa Brasil acredita no desenvolvimento sustentável do país e colabora evitando desperdício de papel. Faça o download do manual Completo em nosso site:
---	--	---

### ◆ Revision History

The revision dates and numbers of the revised manuals are given on the bottom of the back cover.

MANUAL NO. TOEP C710606 14C

Published in Japan November 2007 07-4 ②

└─ Date of publication

└─ Date of original publication

└─ Revision number

Date of Publication	Rev. No.	Section	Revised Content
April 2007	—	—	First edition
June 2007	①	All	Addition: CIMR-V□BA0018 Addition: Safety Input Usage
		Chapter 2	Revision: Drive Weight
		Chapter 7	Addition: U4-08
		Chapter 8	Revision: EMC Filters
November 2007	②	All	Revision: A1-06 Settings
		Chapter 8	Revision: Safe Disable Input Wiring Addition: V1000- ORIENTAÇÃO BÁSICA
September 2008	③	All	Addition: IP00 Three-Phase 200 V Class: CIMR-V□2A0030A to 0069A Three-Phase 400 V Class: CIMR-V□4A0018A to 0038A
		Chapter 1	Addition: Component Name
		Chapter 2	Revision: Dimensions
February 2009	④	Chapter 5	Addition: Alarm AEr, LT-1 to 4, TrPC
			Addition: F6-20 to F6-24
		Chapter 7	Addition: H3-14, -16, -17; L4-08; H1-□□ = 4E, 4F
			H2-□□ = 2F, 4E, 4F; H3-□□ = 41

**This Page Intentionally Blank**

---

**This Page Intentionally Blank**

# YASKAWA AC Drive-V1000

## Compact Vector Control Drive

### Quick Start Guide

---

#### **IRUMA BUSINESS CENTER (SOLUTION CENTER)**

480, Kamifujisawa, Iruma, Saitama, 358-8555, Japan  
Phone: 81-4-2982-5696 Fax: 81-4-2982-6138

#### **YASKAWA ELECTRIC CORPORATION**

New Pier Takeshiba South Tower, 1-16-1, Kaigan, Minatoku, Tokyo, 105-6891, Japan  
Phone: 81-3-5402-4511 Fax: 81-3-5402-4580  
<http://www.yaskawa.co.jp>

#### **YASKAWA ELECTRIC AMERICA, INC.**

2121 Norman Drive South, Waukegan, IL 60085, U.S.A.  
Phone: (800) YASKAWA (800-927-5292) or 1-847-887-7000 Fax: 1-847-887-7370  
<http://www.yaskawa.com>

#### **YASKAWA ELÉTRICO DO BRASIL COMÉRCIO LTDA.**

Avenda Fagundes Filho, 620 Bairro Saude, São Paulo, SP04304-000, Brasil  
Phone: 55-11-3385-1100 Fax: 55-11-5581-8795  
<http://www.yaskawa.com.br>

#### **YASKAWA ELECTRIC EUROPE GmbH**

Hauptstraße 185, 65760 Eschborn, Germany  
Phone: 49-6196-569-300 Fax: 49-6196-569-398

#### **YASKAWA ELECTRIC UK LTD.**

1 Hunt Hill Orchardton Woods, Cumbernauld, G68 9LF, United Kingdom  
Phone: 44-1236-735000 Fax: 44-1236-458182

#### **YASKAWA ELECTRIC KOREA CORPORATION**

7F, Doore Bldg. 24, Yeoido-dong, Youngdungpo-Ku, Seoul, 150-877, Korea  
Phone: 82-2-784-7844 Fax: 82-2-784-8495

#### **YASKAWA ELECTRIC (SINGAPORE) PTE. LTD.**

151 Lorong Chuan, #04-01, New Tech Park, 556741, Singapore  
Phone: 65-6282-3003 Fax: 65-6289-3003

#### **YASKAWA ELECTRIC (SHANGHAI) CO., LTD.**

No. 18 Xizang Zhong Road, Room 1702-1707, Harbour Ring Plaza, Shanghai, 200001, China  
Phone: 86-21-5385-2200 Fax: 86-21-5385-3299

#### **YASKAWA ELECTRIC (SHANGHAI) CO., LTD. BEIJING OFFICE**

Room 1011A, Tower W3 Oriental Plaza, No. 1 East Chang An Ave.,  
Dong Cheng District, Beijing, 100738, China  
Phone: 86-10-8518-4086 Fax: 86-10-8518-4082

#### **YASKAWA ELECTRIC TAIWAN CORPORATION**

9F, 16, Nanking E. Rd., Sec. 3, Taipei, Taiwan  
Phone: 886-2-2502-5003 Fax: 886-2-2505-1280



YASKAWA ELECTRIC CORPORATION

YASKAWA

In the event that the end user of this product is to be the military and said product is to be employed in any weapons systems or the manufacture thereof, the export will fall under the relevant regulations as stipulated in the Foreign Exchange and Foreign Trade Regulations. Therefore, be sure to follow all procedures and submit all relevant documentation according to any and all rules, regulations and laws that may apply.

Specifications are subject to change without notice for ongoing product modifications and improvements.

© 2007-2009 YASKAWA ELECTRIC CORPORATION. All rights reserved.



\*10EPC71060614\*

MANUAL NO. TOEP C710606 14E

Published in Japan February 2009 07-4   
09-1-3\_YEA