

OVERVIEW

The following procedure is a supplement to other documentation supplied with this equipment and will guide the user in properly wiring the V1000 and motor. It will also allow the installer to check motor direction, correct if necessary and perform a motor Auto-Tune.

DANGER: Improper wiring can and will cause bodily harm as well as damage to the equipment.

When installing the system be sure to follow good wiring practices and all applicable codes. Ensure that the mounting of the various components are secure and that the environment, such as extreme dampness, poor ventilation etc. will not cause system degradation.

Please read this cheat sheet and other documentation provided with the V1000 thoroughly before attempting any installation.

Step 1 V1000 Model Identification and Mounting

To make sure you received the correct model it is essential to verify the V1000 nameplate with your order; and make sure that the drive has the correct rating so it can be used with your motor. Please check the nameplate information as shown in the example below.

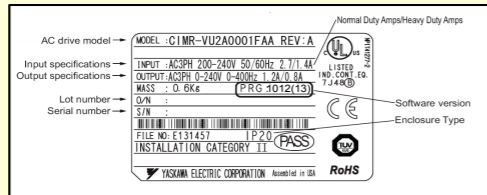

- Check that the available power meets the **input power** requirements.
- Ensure that the **output power** from the VFD is compatible with the motor requirements.
- In the case of systems with multiple VFDs, follow the above procedure for each VFD and motor.

Mounting the V1000

The mounting of the V1000 is extremely important regarding environment and accessibility. Depending on your system, there are various models available and the mounting dimensions (footprint) may be different. Because the mounting procedure is fairly extensive, it is beyond the scope of this document, the user is referred to the V1000 Quick Start Guide (Manual No. TOEPC71060614) received with the V1000, **Section 1 Physical Installation**. Match the model that you received and follow the procedure described in the manual to ensure a safe and functional installation. In cases where the system has more than one V1000, refer to the proper clearances required for adequate ventilation. *Please pay particular attention to:*

- The clearances to be maintained around the enclosure for adequate ventilation.
- The environmental specifications such as avoiding excessive dampness, extreme temperatures, chemical exposure, corrosive areas etc. to avoid damage to the equipment and to maintain safety.

Removing Protective Covers

Improper removal of the V1000 protective covers, as well as the conduit bracket (NEMA 1) can cause extensive damage to the V1000. To avoid damage to these items, please pay particular attention to the V1000 Quick Start Guide, Section 3, **Protective Covers**.

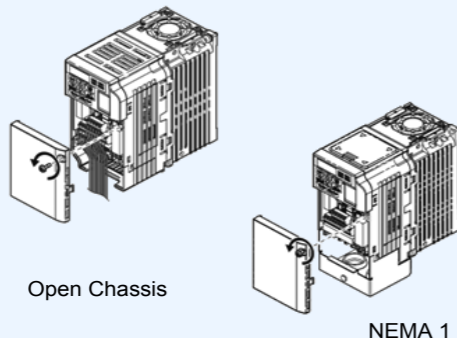

Step 2 Connect Motor and Line Power

Fig.1 & 2 below show the electrical connections for the input power and motor terminals for various V1000 Drive Models. Select the proper diagram for the single or three phase model you are installing (see Step 1) and **WITH POWER OFF**, make the appropriate connections. **Make sure to follow good wiring practices and all applicable codes. Ensure that the equipment is grounded properly as shown.**

DANGER: LETHAL VOLTAGES ARE PRESENT. Before applying power to the V1000, ensure that all protective covers are fastened and all wiring connections are secure. After the power has been turned OFF, wait at least five minutes until the charge indicator extinguishes completely before touching any wiring, circuit boards or components.

WARNING! DO NOT CONNECT ANY OF THE FOLLOWING TERMINALS TO EARTH GROUND

B1 B2 - + +1 +2

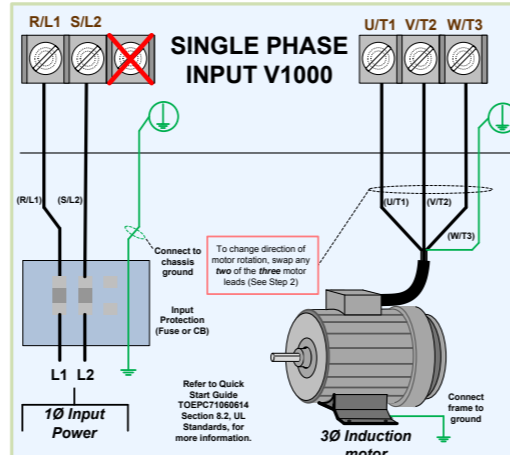

Fig. 1: Input Power and Output Motor Electrical Connections for Single Phase Input V1000

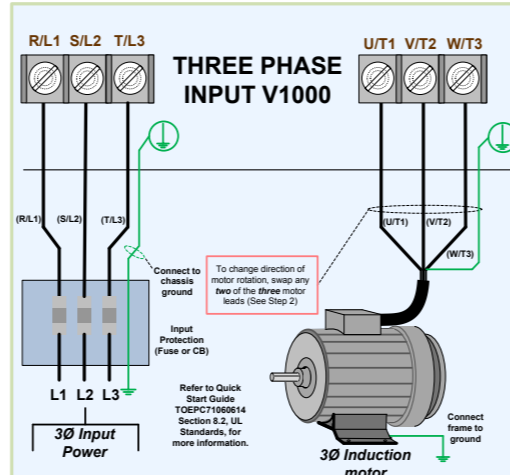

Fig. 2: Input Power and Output Motor Electrical Connections for Three Phase Input V1000

Step 3 Check Motor Direction

In this step the motor is checked for proper direction and operation. This test is to be performed solely from the digital operator. Apply power to the V1000 after all the electrical connections have been made and protective covers have been re-attached. At this point, **DO NOT RUN THE MOTOR**, the Digital Operator should display as shown below in Fig. 3.

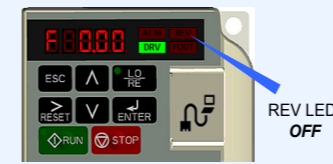

Fig. 3 Digital Operator

Next, press **LO RE** on the Digital Operator; the green LED should turn on **LO RE**, then press **ENTER**.



Next, press **▲** on the Digital Operator once, then press **ENTER**.



Next, press **▶ RUN** on the Digital Operator. The motor should now be operating at low speed running in the correct forward (clockwise) direction.

Next, press **STOP** on the Digital Operator.

If motor rotation is not correct, then power down the V1000 Drive.

DANGER

After the power has been turned OFF, wait at least five minutes until the charge indicator extinguishes completely before touching any wiring, circuit boards or components.

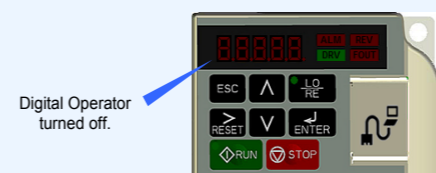

Digital Operator turned off.

Use precaution, and refer to Fig.1 or 2, swap any two of the three output leads to the motor (U/T1, V/T2 and W/T3). After the wiring change, repeat Step 3 and recheck motor direction.

Step 4 Auto-Tuning

In this step the V1000 is set up for use with the motor. Make sure all protective covers have been re-attached then apply power to the V1000. **DO NOT RUN THE MOTOR.**

The procedure indicated here applies for Open Loop Vector (OLV) control (A1-02 = 2). For V/f control Auto-Tuning, only the parameters with a "W" will appear. For more detail, please refer to Quick Start Guide TOEPC71060614 Section 4.7, Auto-Tuning.

Press **▼** once until the Digital Operator shows the Auto-Tuning menu (A.Tun) then press **ENTER**.

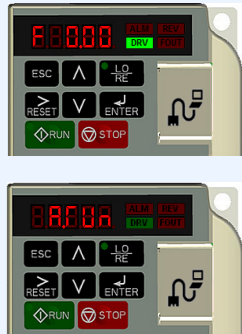

Press **▲** once until the Digital Operator shows parameter T1-02 then press **ENTER**.

Enter Motor Power in kW (Kilowatt)

Press **▶ RESET** to select the digit you would like to change and use the **▲** and **▼** to adjust the value, then press the **ENTER** to save the value.

Press **▲** to go to select the next parameter and follow the same procedure described above to adjust its value.

- 0.1000 Motor Rated Voltage (e.g. 230 V, 460 V)
- 0.1004 Motor Rated current (e.g. 11.0 A, 22.0 A)
- 0.1005 Motor Base Frequency (e.g. 60.0 Hz)
- 0.1006 Motor Poles (e.g. 4 Poles)
- 0.1007 Motor Rated Speed (e.g. 1750 rpm)

For standard AC motors use the default setting for motor base frequency (60Hz), motor poles (4) and motor rated speed.

After setting parameter T1-07 press **▲** to select the Auto-Tuning start command.

Warning! Sudden movement hazard. The V1000 and motor may start unexpectedly during Auto-Tuning.

Warning! Electric Shock Hazard. High voltage will be supplied to the motor when stationary Auto-Tuning is performed. Do not touch the motor during auto-tuning.

Notice: Auto-Tuning will not function properly when a brake is engaged on the load. Ensure the motor shaft can freely rotate. Never perform an Auto-Tune with motor connected to a load.

Next, press **▶ RUN** on the Digital Operator; The V1000 will now start the Auto-Tuning procedure (display flashes).

The display will show **0.0000** when the Auto-Tuning procedure has been successfully completed. Please reference the V1000 Quick Start Guide or repeat the Auto-Tuning procedure again if the display shows an error message.

Step 5 **Changing Parameters and Monitoring the V1000**

This step shows how to access and modify a V1000 parameter as well as how to monitor V1000 signals such as output frequency and motor current.

Make sure all protective covers have been re-attached and power is turned on. **DO NOT RUN THE MOTOR.**

Access Parameter Menu and Change Parameter Value

V1000 Digital Operator power-up state →

Press **↓** two times until the digital operator shows the parameter menu (PAr) then press **ENTER**.

Press **RESET** to select the digit you would like to change. Next use **↑** and **↓** to select the parameter group, sub-group or number.

Modify the parameter value using **↑** and **↓** and press **ENTER** to save the new value.

Select Parameter Menu

Select Parameter

Change Parameter Value

Monitor Motor Frequency and Motor Current

V1000 Digital Operator power-up state →

Press **↑** until the **FOUT** LED turns on. The display now shows the actual drive output frequency in Hz.

Pressing **↑** again will show the motor output current. The 'A' behind the value means 'Amps'.

Output Frequency

Motor Current

Please refer to the technical manual on how to access other drive monitors.

Step 6 **Selecting Start/Stop and Speed Method**

This step shows how to setup up the sequence and reference method of the V1000. The sequence method determines how the V1000 drive receives its start and stop command and the reference method determines how the speed of the motor is controlled. Make sure all protective covers have been re-attached and power is turned on. **DO NOT RUN THE MOTOR.**

This section may require you to change one or more V1000 parameters. Please refer to Step 5 for a detailed explanation on how to change parameters.

SELECT SPEED METHOD b1-01

1. Adjust motor speed / frequency from the Digital Operator

Go to parameter b1-01, **63-01** → **62450**

To adjust frequency use **↓** / **↑** and press **ENTER**.

2. Speed Reference from external terminals

Go to parameter b1-01, **63-01** → **00001** (Factory Default)

Potentiometer 2K Ohm

0 ~ 10Vdc V (Factory Default)

4 ~ 20mA V I

SELECT START / STOP CONTROL METHOD b1-02

1. Start / Stop Control from Digital Operator

Go to parameter b1-02, **63-02** → **00000**

2. Start / Stop Control from external terminals (switch or relay contact)

Go to parameter b1-02, **63-02** → **00001** (Factory Default)

Wiring Diagram: 2-Wire Control
Use for maintained contacts

Wiring Diagram: 3-Wire Control
Use for momentary contacts
(Set Parameter A1-03 to 3330)

NOTE: It is beyond the scope of this document to program the V1000 drive for network communication control. Please refer to the programming manual for this selection.

Step 7 **Quick Start Parameters**

The following table lists the general purpose application parameters as well as frequently asked questions.

This section may require you to change one or more V1000 parameters. Please refer to Step 5 for a detailed explanation on how to change parameters.

GENERAL PURPOSE APPLICATION PARAMETERS

Parameter	Default Value	Description	Comments
b1-01	1	Reference Source / Speed Control Method	0 = Digital Operator (Adjust Motor Speed from keypad) 1 = Terminals (Speed Pot. / 0 – 10V / 4–20mA)
b1-02	1	Run Source / Start/Stop Control Method	0 = Digital Operator (Start/Stop motor from keypad) 1 = Terminals (Start/Stop using external contact / switch)
b1-03	1	Stop Method Selection	0 = Ramp to stop (Motor ramps down at stop command) 1 = Coast to stop (Motor freewheels at stop command)
b1-04	0	Reverse Operation	0 = Allow motor to run in reverse direction 1 = Reverse direction prohibited
C1-01	10.0 sec.	Acceleration Time	The time it takes to ramp up from 0 to maximum motor speed.
C1-02	10.0 sec.	Deceleration Time	The time it takes to ramp down from maximum motor speed to 0.
C6-01	1	Normal / Heavy Duty	0 = Normal Duty (Use for fan and pump applications) 1 = Heavy Duty (Use for conveyor, mixer, applications)
d1-01	0.00 Hz	Frequency Reference	Frequency setting when speed is set from the keypad.
d2-01	100.0 %	Frequency Upper Limit	Maximum motor speed allowed (e.g. 100 % = Max rpm)
d2-02	0.0 %	Frequency Lower Limit	Minimum motor speed allowed (e.g. 100 % = Max rpm)
E2-01	*	Motor Rated Current	Motor nameplate current
L1-01	1	Motor Overload Selection	0 = Disabled 1 = Standard Fan Cooled Motor 2 = Standard Blower Cooled Motor 3 = Vector Duty Motor
L1-02	1.0 min	Motor Overload Time	Sets the motor thermal overload protection time.

FREQUENTLY ASKED QUESTIONS

- Question:** How do I reset the drive back to factory default settings?
Answer: Go to parameter A1-03 and set value **2220** for 2 wire control or **3330** for 3 wire control (Please refer to Step 6 for wiring diagram)
- Question:** How do I adjust the time it takes the motor to speed up or slow down?
Answer: Adjust the acceleration time parameter C1-01 and deceleration time C1-02.
- Question:** How do I prevent my drive from tripping on an **OV** fault (overvoltage) while my motor is ramping down?
Answer: Increase deceleration time parameter C1-02.
- Question:** How do I prevent my drive from tripping on an **OL1** fault (overload) while my motor is ramping down?
Answer: Verify motor rated current parameter E2-01 and motor overload parameter settings L1-01 Motor overload selection, L1-02 Motor overload protection time.
- Question:** I want to run my motor above the nominal motor speed?
Answer: Increase the value of parameter E1-04 Maximum Frequency
Warning! Verify that the motor and system allow for this.