

**TOSVERT VF-S11**

---

*DeviceNet*<sup>™</sup> Option Instruction Manual

---

**DEV001Z-1**

---

**NOTICE**

1. Make sure that this instruction manual is delivered to the end user of DeviceNet built-in option board.
2. Read this manual before installing or operating the DeviceNet built-in board option.  
And keep it in a safe place for reference.
3. All information contained in this manual are subject to change without notice.  
Please confirm the latest information on our web site "[www.inverter.co.jp](http://www.inverter.co.jp)".





\*E6581271REV03\*

# Safety precautions

On the inverter and in its instruction manual, important information is contained for preventing injuries to users and damages to assets and for proper use of the device. Read the instruction manual attached to VF-S11 along with this instruction manual for completely understanding the safety precautions, the symbols and indications shown below. Please adhere to the contents of these manuals at all times.



## Explanation of markings

Marking	Meaning of marking
 Warning	Indicates that errors in operation may lead to death or serious injury.
 Caution	Indicates that errors in operation may lead to injury (*1) to people or that these errors may cause damage to physical property. (*2)

(\*1) Such things as injury, burns or shock that will not require hospitalization or long periods of outpatient treatment.

(\*2) Physical property damage refers to wide-ranging damage to assets and materials.



## Meanings of symbols

Marking	Meaning of marking
	Indicates prohibition (Do not do it). What is prohibited will be described in or near the symbol in either text or picture form.
	Indicates something mandatory (must be done). What is mandatory will be described in or near the symbol in either text or picture form.
	Indicates warning. What is warned will be described in or near the symbol in either text or picture form. Indicates caution. What the caution should be applied to will be described in or near the symbol in either text or picture form.



■ Limitation of use

<b>⚠ Safety precaution</b>	
<p>▼ Never use this unit with any device other than TOSVERT VF-S11 series inverters. Doing so may cause an accident.</p>	



■ Handling in general

<b>⚠ Warning</b>	
 Never Disassemble	<ul style="list-style-type: none"> <li>• Never disassemble, modify or repair the product. Disassembling the product could cause electric shocks, fire or injuries. For repairs, call your agency.</li> </ul>
 Prohibited	<ul style="list-style-type: none"> <li>• Do not remove this option from VF-S11 when the power is on. It could lead to electric shocks.</li> <li>• Do not put or insert foreign objects such as waste cable, bars, or wires into the product. It could lead to electric shocks or fire.</li> <li>• Do not splash water over the product. It could lead to electric shocks or fire.</li> </ul>
 Mandatory	<ul style="list-style-type: none"> <li>• Wiring should be conducted after turning VF-S11 power off.</li> <li>• Turn off the power immediately in case any abnormalities such as smokes, smells or abnormal noise are found. Neglect of these conditions could lead to fire. For repairs, call your agency.</li> </ul>



■ Transportation and installation

<b>⚠ Warning</b>	
 Prohibited	<ul style="list-style-type: none"> <li>• Do not install or operate the inverter if it is damaged or any part is missing from it. Operating a defective inverter could lead to electric shocks or fire. For repairs, call your agency.</li> <li>• Do not put any inflammable material near the product. It could catch fire if the product sparks because of a breakdown and the like.</li> <li>• Do not install the product where it could be splashed with water and the like. It could lead to electric shocks or fire.</li> </ul>
 Mandatory	<ul style="list-style-type: none"> <li>• The product must be used under environmental conditions prescribed in this instruction manual. Using the product under conditions not specified by the instruction manual could lead to breakdown.</li> <li>• Install this option in VF-S11 and tighten the screws to the specified torque. Otherwise it could lead to breakdown.</li> </ul>
 Caution	<ul style="list-style-type: none"> <li>• Be careful of the option board when you exchange the terminal boards. Otherwise it can cause injury to people.</li> </ul>



■ **Wiring**

 <b>Warning</b>	
 Mandatory	<ul style="list-style-type: none"> <li>• Turn off input power before wiring. Wait at least ten minutes and check to make sure that the charge lamp (on VF-S11 unit) is no longer lit.</li> <li>• Tighten the screws on the terminal board to the specified torque. If the screws are not tightened to the specified torque, it could lead to fire.</li> <li>• Electrical construction work must be done by a qualified expert. Connection of input power by someone who does not have that expert knowledge may result in fire or electric shock.</li> </ul>

■ **About operation**

 <b>Warning</b>	
 Prohibited	<ul style="list-style-type: none"> <li>• Do not wipe the body with a wet cloth. Don't touch the body with your wet hand. It could lead to electric shocks.</li> <li>• Do not pull on the cable It could cause damage or error.</li> </ul>
 Mandatory	<ul style="list-style-type: none"> <li>• Check DeviceNet state (using below attribute) when the option unit is deactivated by an unusual event such as an operating error, power outage, failure, etc.                             <ul style="list-style-type: none"> <li>- Identity Object Instance Attributes 8 (State) (The communication error occurs when Fault (4, 5) or this value cannot be read.)</li> </ul>                             Deactivated option unit may cause an accident, if the DeviceNet state is not checked.                         </li> <li>• Make sure that the operation signals are STOP before clearing the inverter's fault. The motor may suddenly start and that may result in injuries.</li> </ul>

■ **About disposal of the product**

 <b>Caution</b>	
 Mandatory	<ul style="list-style-type: none"> <li>• For safety's sake, do not dispose of the disused inverter yourself but ask an industrial waste disposal agent (*). If the collection, transport and disposal of industrial waste is done by someone who is not licensed for that job, it is a punishable violation of the law. (Laws in regard to cleaning and processing of waste materials)</li> </ul> (*) Persons who specialize in the processing of waste and known as "industrial waste product collectors and transporters" or "industrial waste disposal persons."

---

**Notes on use**

---

**NOTES**

- Avoid installation locations that may be subjected to rapid changes in ambient temperature or/and humidity.
- Separate the communication cable from the inverter input/output power wiring 20cm or more. When disconnecting connection cable, make sure to hold its connector with care not to give unreasonable stress to the cable and the unit.
- Separate the ground of SHIELD terminal on the DeviceNet built-in board option from those of the inverter and the motor. It could cause malfunction due to noise.
- Install this board inside the VF-S11 and secure it with board fixing screws, otherwise it could fall and cause malfunction or breakdown.
- Connect an electromagnetic contactor or the like between the inverter and the power source to secure external control of emergency stop of operation.

# Introduction

Thank you for purchasing the “DeviceNet built-in board option (DEV001Z)” for TOSVERT VF-S11 inverter. Installing this board in the VF-S11 and using it together, data communication can be made with a host computer or other device via DeviceNet. Please read the entire manual carefully before attempting to control your inverter via DeviceNet connection.

Besides this instruction manual, the “DEV001Z Function Manual” is required to develop software communicating with VF-S11. In such a case, please get in touch with our branch offices or sales offices. (“DEV001Z Function Manual”: E6581268)

This manual is also aimed at the operator using "DeviceNet built-in board option", so please use it for future maintenance and inspection.

## ■ Explanation of model number of DeviceNet™ Option Unit

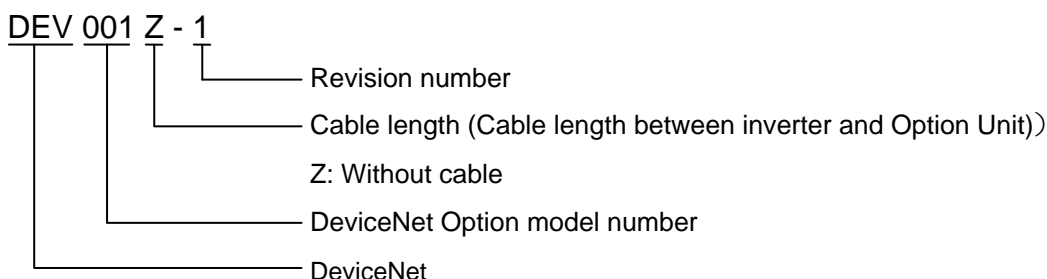

## ■ Check of accessories

DeviceNet built-in board option is shipped together with the following items in the package. Contact your sales agency if any of these is missing

- (1) DeviceNet built-in board option ..... 1 board (DEV001Z)
- (2) DeviceNet open connector ..... 1 pcs  
(Connected to DEV001Z)

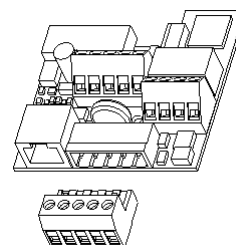

- (3) Instruction manual of DeviceNet built-in board option ..... 1 copy  
( Japanese..... E6581215 )  
( English ..... E6581271 )

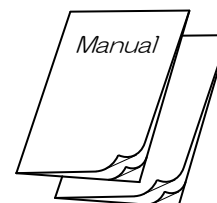

- (4) DeviceNet built-in board option cabling label ..... 1 pcs.  
Type form label ..... 2 pcs.  
Insulating sheet ..... 1 pcs.



---

# Table of Contents

---

1. OVERVIEW.....	7
2. NAMES AND FUNCTIONS .....	8
2.1. Control Circuit terminals.....	9
2.2. DeviceNet indicators (Status LED) .....	11
2.3. Common Serial Communication Connector .....	12
2.4. DeviceNet Connector.....	12
3. CONNECTION TO THE DEVICE .....	13
4. CONNECTION TO THE NETWORK.....	15
4.1. Installation method .....	15
4.2. Network Grounding .....	15
5. VF-S11 COMMUNICATION PARAMETERS .....	16
5.1. <i>F800</i> Communication Rate setting .....	17
5.2. <i>F890</i> MAC ID Setting.....	17
5.3. <i>F891</i> Network Baud Rate setting .....	17
5.4. <i>F892</i> Communication Loss Action Setting (Network breaks).....	17
5.5. <i>F893</i> Preset Speed No. Setting.....	18
5.6. <i>F894</i> Assembly Object Setting .....	18
6. DEVICENET LOCAL/REMOTE OPERATION.....	19
7. SPECIFICATIONS.....	20
8. WARRANTY .....	20

# 1. Overview

The DEV001Z interface allows the VF-S11 inverter to be connected into a DeviceNet network. DeviceNet supports a maximum of 64 nodes, allowing for the Master unit and the configuration tool a maximum of 62 devices can be connected to the network.

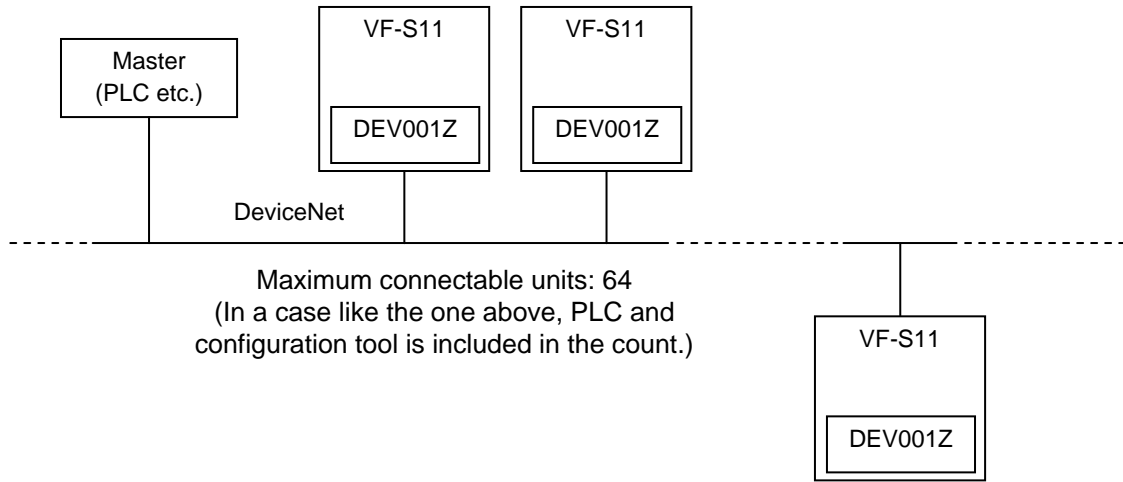

## 2. Names and functions

The external view of this option and the name of each part are shown below:

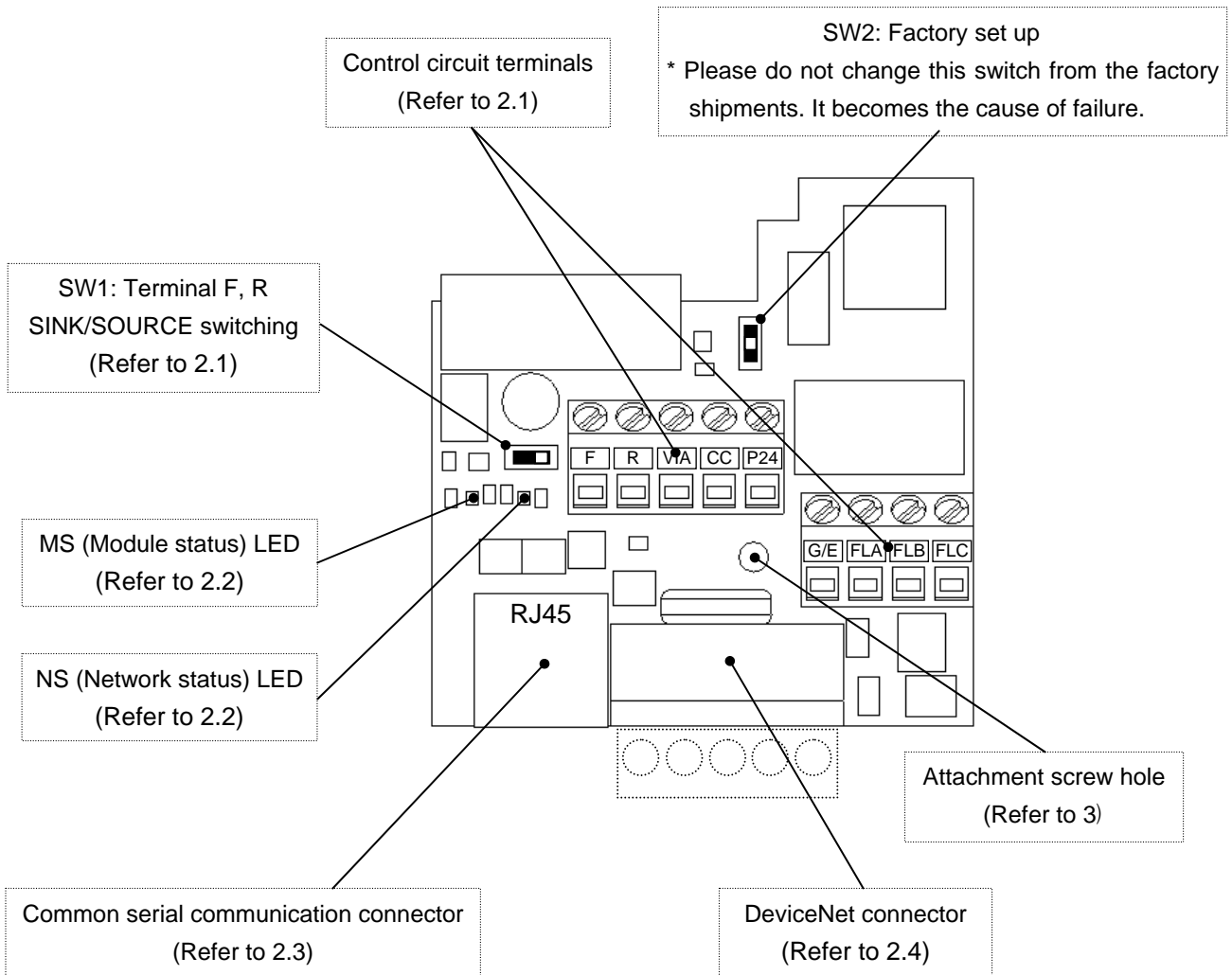

## 2.1. Control Circuit terminals

The control circuit terminal's function is as follows.

Terminal Symbol	Input/ Output	Function	Electrical specification
F	Input	Multifunction programmable contact input. Shorting across F-CC causes forward rotation; open causes slow-down and stop.	No-voltage contact input 24V <sub>DC</sub> 5mA and less * Sink logic/source logic switchable
R	Input	Multifunction programmable contact input. Shorting across R-CC causes reverse rotation; open causes slow-down and stop.	
VIA	Input	Multifunction programmable analog input. Factory default setting: 0-10V <sub>DC</sub> and 0-60Hz frequency input. By changing parameter setting ( <i>F 109, F 118</i> ), this terminal can also be used as a multifunction programmable contact input terminal. When using the sink logic, be sure to insert a resistor between P24-VIA (4.7k ohm-1/2 W).	10V <sub>DC</sub> (internal impedance: 30k ohm)
CC	Common to I/O	Control circuit's equipotential terminal.	
P24	Output	24V <sub>DC</sub> power output	24V <sub>DC</sub> -100mA
G/E	Grounding	Grounding terminal. Connect to local ground for RF termination of the DeviceNet cable.	-
FLA FLB FLC	Output	Multifunction programmable relay contact output. Detects the operation of the inverter's protection function. Contact across FLA-FLC is closed and FLB-FLC is opened during protection function operation.	250V <sub>AC</sub> -1A ( $\cos \phi = 1$ ) 30V <sub>DC</sub> -0.5A 250V <sub>AC</sub> -0.5A ( $\cos \phi = 0.4$ )
V+ (Red)	DeviceNet	Network power supply V+ Power conductor.	Conform to DeviceNet specification
CAN_H (White)		Network High-level signal conductor.	
SHIELD (Bare)		Shield conductor.	
CAN_L (Blue)		Network low-level signal conductor.	
V- (Black)		Network power supply V- Power conductor.	

\* For internal circuits, please refer to the VF-S11 Instructions Manual.

### Wire size

Solid wire: 0.3 - 1.5 (mm<sup>2</sup>)

Stranded wire: 0.3 - 1.5 (mm<sup>2</sup>)



(AWG 22 - 16)

Sheath strip length: 6 (mm)

Torque: 0.5 - 0.6N·m

Screwdriver: Small-sized flat-blade screwdriver

(Blade thickness: 0.6 mm or less, blade width: 3.5 mm or less)

<b>⚠ Warning</b>	
 Prohibited	<ul style="list-style-type: none"> <li>Do not change switch settings while power is on. Changing switches while power is on can damage the product. It could lead to electric shocks, damage and breakdown.</li> </ul>
 Mandatory	<ul style="list-style-type: none"> <li>When setting the VIA function, set the parameter and SW1 after confirming removed motor cables. The motor may suddenly start and that could result in injury.</li> <li>Do not change SW2 from the factory shipments. It becomes the cause of failure.</li> </ul>

\* Separate the communication cable from the inverter input/output power wiring 20cm or more.

Wiring them close to each other may lead to malfunction due to noise.

\* When the operation is to be controlled using a programmable controller which is the open collector output type, if the programmable controller is turned off with the inverter is on, the difference between each control power potential will cause wrong signals to the inverter as shown in below figure. Be sure to provide an interlock so that the programmable controller cannot be turned off when the inverter is on.

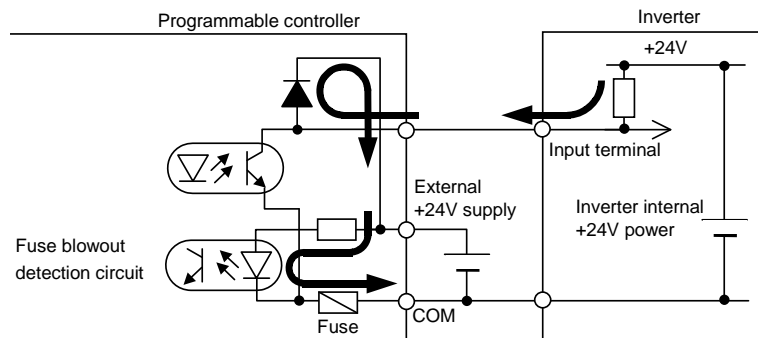

## 2.2. DeviceNet indicators (Status LED)

### MS (Module status)

This bi-color (green/red) LED indicates the status of the communication link from DEV001Z to the VF-S11. It indicates whether or not the device has power and is operating properly. (According to ODVA DeviceNet Specifications.)

LED is:	For this state:	To indicate:
Off	Power OFF	There is no power applied to the device.
Green	Device Operational	The device is operating in a normal condition.
Flashing Green	Device in Standby	The device needs commissioning due to configuration missing, incomplete or incorrect. * When a setup of the parameter <i>F890 - F894</i> is outside the range, it will be in this state. The Device may be in the Standby state.
Flashing Red	Minor Fault	Recoverable Fault
Red	Unrecoverable Fault	The device has an unrecoverable fault; may need replacing.
Flashing Red-Green	Device Self Testing	The Device is in Self Test.

### NS (Network status)

This bi-color (green/red) LED indicates the status of the communication link from the DEV001Z to DeviceNet. (According to ODVA DeviceNet Specifications.)

LED is:	For this state:	To indicate:
Off	Not Powered/Not On-line	Device is not on-line. - The device has not completed the Dup_MAC_ID test yet. - The device may not be powered, look at Module Status LED.
Green	On-line and connect	The device is on-line and has connections in the established state. - The device is allocated to a Master.
Flashing Green	On-line, not connect	Device is connected to the network but has no connections in the established state. - The device is not allocated to a master.
Flashing Red	Connection Time-out	Recoverable Fault. One or more I/O Connections are in the Timed-Out state.
Red	Critical Link Failure	Non Recoverable fault. The device has detected an error that has rendered it incapable of communicating on the network (Duplicate MAC ID, or Bus-off). Check parameters <i>F890, F891</i> then Cycle power to VF-S11 to reset this fault.

## **Warning**



**Mandatory**

- Do not open the terminal block cover while power is on about the model below VFS11-2022, below -4015, and below VFS11S-2015. It could lead to electric shocks.

## 2.3. Common Serial Communication Connector

It is possible to use the following Common Serial Options.

- RS232C communication Unit (RS2001Z)
- RS232C Communication Cable (RS20035)
- RS485 Communication Unit (RS4001Z, RS4002Z)
- Maintenance Communication Application (PCM001Z)\*
- Setup Communication Application (PCS001Z)

\* "Keypad" menu cannot be used. It is displayed as "E".

It is impossible to use the following Common Serial Options. It is displayed as "E".

- Remote Control Panel (RKP001Z)
- Parameter Writer (PWU001Z)

## 2.4. DeviceNet Connector

DeviceNet network cable is connected. The terminal is a plug-type and the signal of each terminal is as follows.

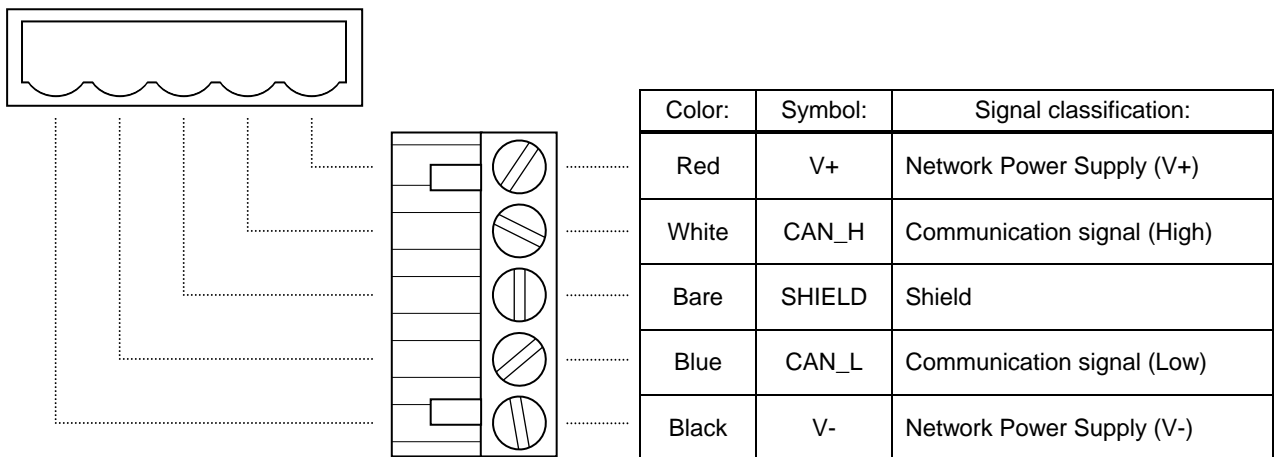

### 3. Connection to the device

Install the DeviceNet built-in board option to VF-S11 as follows:

Please complete the wiring of the main circuit power supply before attaching the DEV001Z.

- (1) Turn off input power of VF-S11 and wait for at least ten minutes and then check that the CHARGE lamp on VF-S11 is no longer lit.
  - (2) Open the VF-S11 front cover, remove the board fixing screw and take out the VF-S11 standard terminal block board.  
(Be careful not to lose the board fixing screw when removed since it will be used again.)
  - (3) Please attach the Insulating sheet in VF-S11 to set to under the DEV001Z.  
(Set to the Board fixing screw hole and PWB catch pin.)
  - (4) Install the DeviceNet built-in board option and secure it with the board fixing screw.  
(M3 tapping screw tightening torque: 0.7 to 0.8N·m)
  - (5) Stick the DEV001Z cabling label on the standard cabling label stuck on the back of the VF-S11 cover. And stick the DEV001Z type form label near the standard name plate. (Be careful not to cover the ventilation slits on the side of the VF-S11 main unit.)
- \* To install or remove the terminal block board, make it slide in or out in parallel with board.

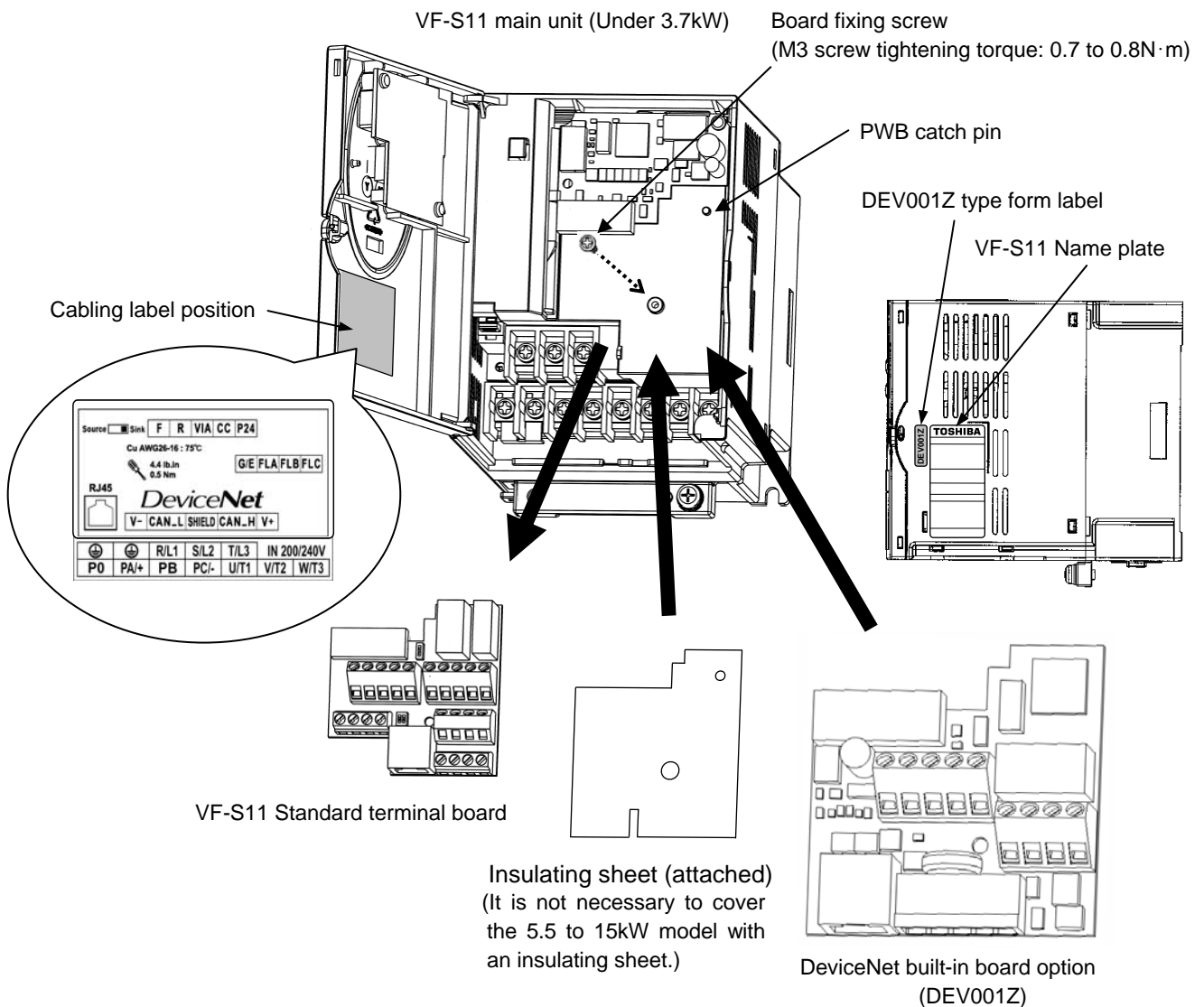

VF-S11 main unit (Over 5.5kW)

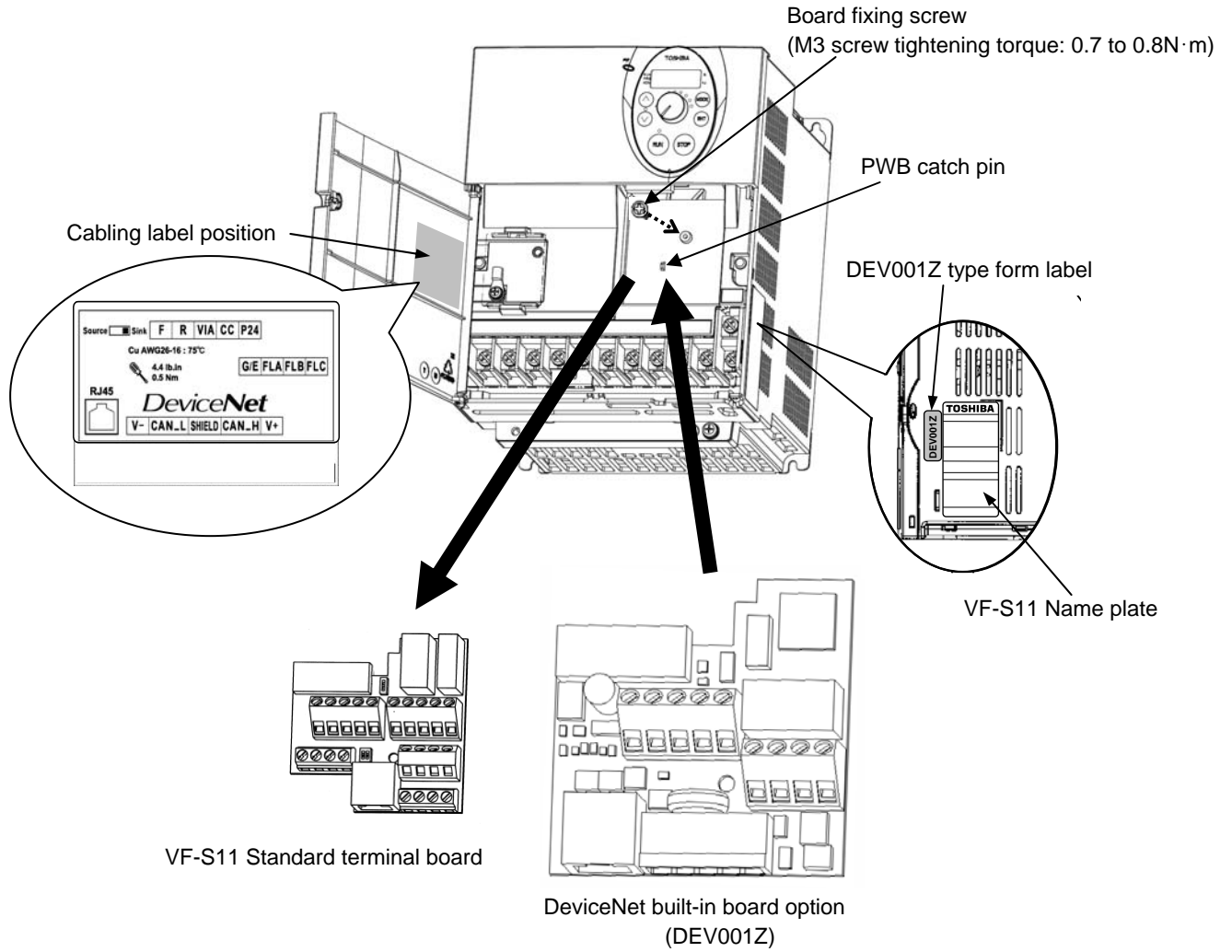

<b>⚠ Warning</b>	
 <b>Mandatory</b>	<p>▼ Be sure to attach an attached insulating sheet. It becomes the case of failure when not attaching. (For the 5.5 to 15kW model, it is unnecessary.)</p>

## 4. Connection to the network

### 4.1. Installation method

- (1) Attach DeviceNet cable to DeviceNet connector. (Refer to 2.4)  
(Be careful not to short-circuit adjacent terminals on DeviceNet connector).
- (2) Please set the terminating resistance if needed.  
<Terminating resistor specification>  
1/4W-121 ohm-1% Metal Film
- (3) Close the terminal cover, set the parameters about DeviceNet (*F890*, *F891* etc.) after power on. (Refer to 5)  
\* We recommend setting the communication speed (*F800*) as 4 (19200bps) .
- (4) Once all the parameters are set, the power must be cycled to the VF-S11 for these changes to take effect.

### 4.2. Network Grounding

Please note the following points regarding the grounding of a DeviceNet network.

- Do not connect the G/E terminal to a power ground or any other potential noise-producing ground connection (such as a drive's "E" terminal). Connect to a close, clean ground to provide RF termination of the DeviceNet cable.
- Do not make connections to unstable grounds (paint-coated screw heads, grounds that are subjected to inductive noise, etc.)

To prevent ground loops, the DeviceNet network should be earth grounded in only one location. No significant current flow between V- and earth ground may occur via any device other than a power supply under normal operating conditions.

(From the ODVA DeviceNet specification)

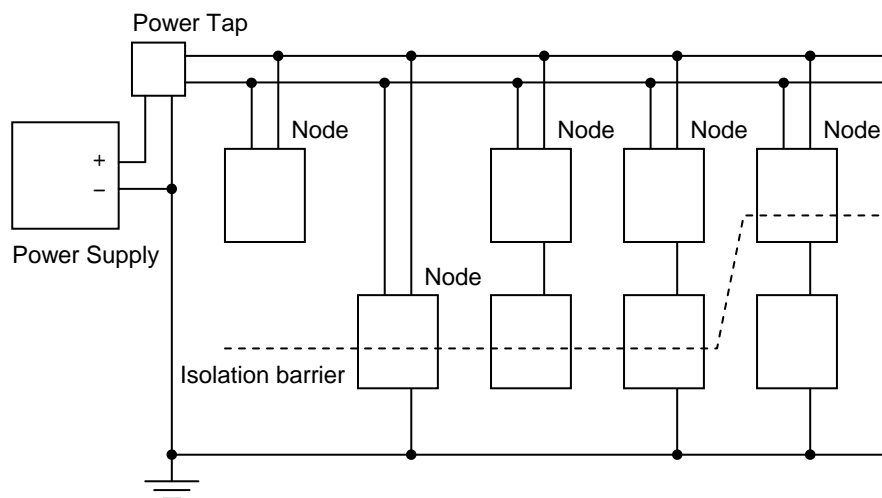

## 5. VF-S11 communication parameters

In a network, VF-S11 (DEV001Z) serves as a DeviceNet slave device. The DEV001Z configuration is set by the following parameters.

The supported parameters for each drive and their allowable adjustment ranges are defined in the appropriate Electronic Data Sheet (EDS) files. EDS files can be downloaded via the internet from

<http://www.inverter.co.jp/product/inv/vfs11/dev/DEV001Z.eds>

Parameter	Function	Adjustment range	Shipment
<i>F800</i>	RJ45 Communication speed	0: 1200bps 1: 2400bps 2: 4800bps 3: 9600bps 4: 19200bps	3
<i>F890</i>	MAC ID	0 - 63	63
<i>F891</i>	DeviceNet Communication speed	0: 125kbps 1: 250kbps 2: 500kbps	0
<i>F892</i>	Communications Loss action (Network wire breaks)	0: Stop, Communication release 1: No action 2: Deceleration stop 3: Coast stop 4: Emergency stop ( $\mathcal{E}$ ) *** 5: Preset speed command (Preset speed by <i>F893</i> setting)	0
<i>F893</i>	Preset speed No.	0: No action 1-15: Preset speed	0
<i>F894</i>	Assembly Object	0: Instance 20/70 1: Instance 21/71 2: Instance 100/150 3: Instance 101/151	0

\* When out of range values are set up, the MS (Module Status) LED and will flash green continuously to indicate an invalid set-up. DeviceNet communication is not possible in this state.

\*\* After change the parameters, the power needs to be turned off and then turned back on. After reset, the parameter changes become effective.

\*\*\* To reset emergency stop ( $\mathcal{E}$ ), the power needs to be turned off and then turned back on.



Please note that inverter keeps driving when the communication is lost if / (None) is set to the parameter *F892* (Inverter operation at the communications loss action).

## 5.1. F800 Communication Rate setting

The communication speed of the RJ45 connector VF-S11 is set up by this parameter. We recommend setting this parameter as 4 (19200bps).

## 5.2. F890 MAC ID Setting

This parameter sets the VF-S11's MAC ID on the network. The MAC ID must be unique and not match any other device on the network.

Note: Changes to this parameter do not take effect until the power is cycled to the VF-S11

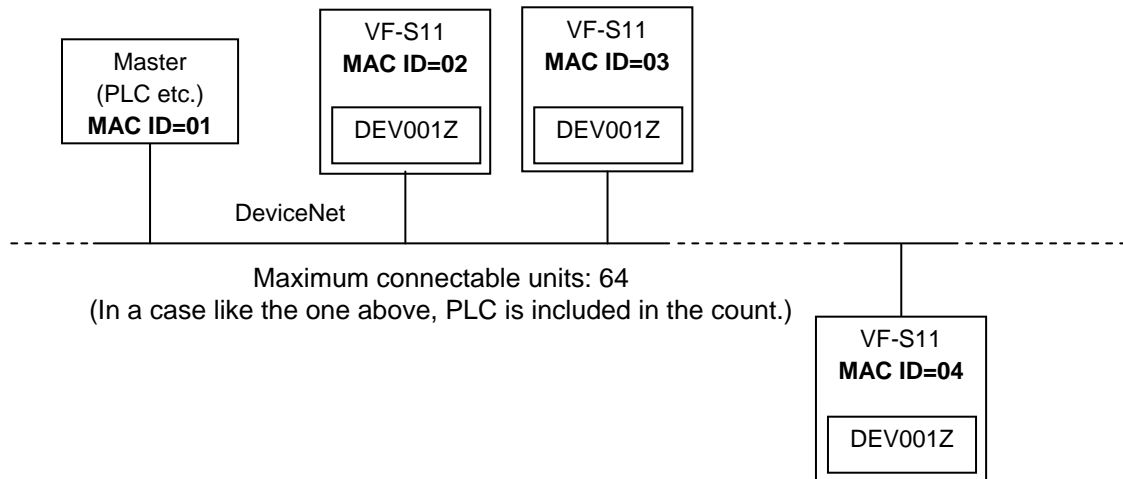

## 5.3. F891 Network Baud Rate setting

This parameter sets the DeviceNet baud rate of the VF-S11 (DEV001Z).

Note: Changes to this parameter do not take effect until the power is cycled to the VF-S11

Value	Baud Rate	Max Trunk Distance	Drop Length	
			Maximum	Cumulative
0	125k baud	500 meters (1640 ft.)	6 meters (20 ft.)	156 meters (512 ft.)
1	250k baud	250 meters (820 ft.)		78 meters (256 ft.)
2	500k baud	100 meters (328 ft.)		39 meters (128 ft.)

## 5.4. F892 Communication Loss Action Setting (Network breaks)

This parameter sets up the VF-S11 response to a loss of communications with the DeviceNet network.

By shipment value, deceleration stop and DeviceNet communication\* release.

\* Local control via the panel/terminal is not possible once the VF-S11 is in this communication loss state.

Note: Changes to this parameter do not take effect until the power is cycled to the VF-S11

## 5.5. F893 Preset Speed No. Setting

If the communication loss action (parameter *F892*) is set to 5 (preset speed command), then the VF-S11 will run at a preset speed as set up by this parameter in the case of a communication loss.

Example.

*F892* (Inverter action on Network breaks) = 5 (Preset speed command)

*F893* (Preset speed No.) = 8 (Preset speed #8)

*F287* (Preset speed #8) = 10 (10Hz)

In case the above is set up, inverter action is as follows.

Network	VF-S11 Action
Normal .....	Drive from Master's command
↓	↓
Break.....	Running on 10Hz
↓	↓
Restored .....	Drive from Master's command

## 5.6. F894 Assembly Object Setting

The Input/Output Instance of DEV001Z is set up by this parameter.

The DEV001Z supports both the standard DeviceNet AC Drive profile Instances 20/70, 21/71 and user defined Instances 100/150, 101/151.

\* About instance 20/70, 21/71, and 101/151 (*F894* = 0, 1, and 3), refer to the function manual (E6581268).

*F894* = 2 (Instance 100/150)

Byte	bit7	bit6	bit5	bit4	bit3	bit2	bit1	bit0
0	DC braking	Acc./Dec. #1/#2	PI off	THR2	Preset Speed 4	Preset Speed 3	Preset Speed 2	Preset Speed 1
1	Command link	Frequency link	Reset trip	Emerg. stop	Free run (ST)	Run/Stop	Forward/Reverse	Jog
2	Drive Reference Speed Hz (Low byte)							
3	Drive Reference Speed Hz (High byte)							

Output Instance 100 format

Byte	bit7	bit6	bit5	bit4	bit3	bit2	bit1	bit0
0	DC braking	Acc./Dec. #1/#2	PI	THR2 (VF2+THR2)	-	ALARM ( <i>F891</i> )	Fault	Fault FL
1	-	READY without ST/RUN	READY with ST/RUN	Emerg. stop	Free run (ST)	Run/Stop	Forward/Reverse	Jog
2	Drive Actual Speed Hz (Low byte)							
3	Drive Actual Speed Hz (High byte)							

Input Instance 150 format

## 6. DeviceNet Local/Remote Operation

The example below shows how to configure the VF-S11 for local / remote operation.

### <Terminal Functions>

- F terminal ..... Operating command
- R terminal ..... DeviceNet/Local (Terminal in this example) switching
- VIA terminal ..... Frequency command

### <Wiring>

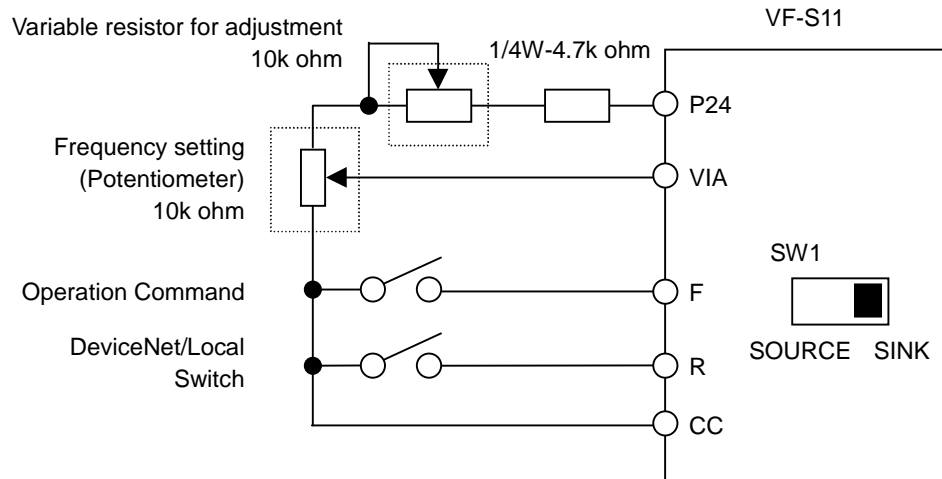

### <Parameter set up>

- $CMD$  (Command mode selection) = 0 (Terminal board)
- $F11$  (Frequency setting mode selection 1) = 1 (VIA)
- $F12$  (Input terminal selection 2 (R)) = 48 (Remote/Local control)

### <Action>

- R-CC terminal open:
  - VF-S11 is controlled as slave device of DeviceNet.
- R-CC terminal closed:
  - F-CC terminal short to RUN
  - F-CC terminal open to STOP
  - Output frequency is set up by the VIA signal input.

## 7. Specifications

Item	Specifications
Part number	DEV001Z
Service environment	Indoors, altitude 1000 m or less, and the following are not allowed: direct sunshine, corrosive and/or explosive gases, steam, powder dust, dust, grinding liquid and grinding oil exposure.
Ambient temperature	-10 to 60°C
Storage temperature	-20 to +65°C
Relative humidity	20 to 93% (without condensation and steam)
Vibration	5.9 m/s <sup>2</sup> (0.6G) or less (10 to 55 Hz) (Conforming to JIS C0040)

This product has been self-tested by Toshiba Schneider Inverter Corporation and found to comply with ODVA Conformance Test Software Version A-17.

## 8. Warranty

Any part of DeviceNet built-in board option that happens to be defective will be repaired free of charge under the following conditions:

1. If and when a trouble occurs on the option board properly installed and handled within one year of delivery, and if the trouble is clearly attributable to defects inherent in our design and manufacturing, the product will be repaired free of charge.
2. The warranty covers only the delivered option board.
3. Even in the term of the warranty, repair service will be charged for the following cases.
  - 1) Fault or damage resulting from misuse, unauthorized modification or repair.
  - 2) Fault or damage resulting from falling down of the product or traffic accident during transportation.
  - 3) Fault or damage originating from fire, salt water/salty breezes, some kind of gas, earthquake, storm or flood, lightning, abnormal supply voltage, or other natural disasters.
  - 4) Fault or damage caused by improper use of this option board as it is used for a purpose out of its original function.
4. If another special warranty is contracted for this option board, the special warranty has priority over this warranty.