

TOSVERT VF-nC1

Communications Function Instruction Manual

Notice

1. Make sure that this instruction manual is delivered to the end user of the inverter.
2. Read this manual before first using the communications function, and keep it handy as a reference for maintenance and inspections.

* The contents of this manual are subject to change without notice.

Toshiba Schneider Inverter Corporation

© TOSHIBA SCHNEIDER INVERTER CORPORATION 2002

All rights reserved.

Read first

Safety precautions

This manual and labels on the inverter provide very important information that you should bear in mind to use the inverter properly and safely, and also to avoid injury to yourself and other people and damage to property.

Read the safety precautions in the instruction manual for your inverter before reading this manual and strictly follow the safety instructions given.

Notice		Reference
<ul style="list-style-type: none"> ◆ Insert an electromagnetic contactor between the inverter and the power supply so that the machine can be stopped without fail from an external controller in case of an emergency. 	<ul style="list-style-type: none"> ◆ The EEPROM (Electrically Erasable Programmable Read-Only Memory) is good for 10,000 times of reprogramming. Unless it is absolutely necessary to store data into the EEPROM, use the P command to write data into the RAM. Do not rewrite data into the same parameter stored in the EEPROM more than 10,000 times, using the W command*. (*: Command allowing you to write data into both the RAM and the EEPROM). 	<p>Inverter instruction manual</p>
<ul style="list-style-type: none"> ◆ Examples in this manual are based on the assumption that communications take place between one inverter and one computer. If connecting two or more inverters to the same network, you will need to assign a number to each of them. Failure to do so will cause a data crash and result in a communications error. 	<ul style="list-style-type: none"> ◆ When using and handling the inverter, strictly follow the instructions given in the instruction manual for your inverter. 	<p>Chapter 4, "Commands"</p> <p>Chapter 5, "Data transmission format"</p>

Contents

1.	General outlines of the communications function.....	3
2.	Data transmission specifications.....	4
3.	Exchange of data between the computer and the inverter	5
3.1.	Brief explanation of the sequence	5
3.2.	Transmission errors.....	7
4.	Commands	8
5.	Data transmission formats	10
5.1.	Data transmission formats used in ASCII mode	10
5.2.	Data transmission formats used in binary mode.....	13
6.	Communications parameters	16
7.	Functions	17
7.1.	Timer function.....	17
7.2.	Broadcast communications function.....	18
8.	Commands and monitoring from the computer.....	20
8.1.	Communication commands (commands from the computer)	20
8.2.	Monitoring from the computer.....	22
9.	Examples of the use of communication commands.....	26
10.	Examples of RS232C communication programs.....	27
11.	Parameter data	29
11.1.	Table of parameters	29
Appendix 1 Table of data codes.....		34
Appendix 2 Response time		35
Appendix 3 Compatibility with the communications function of the VF-S7		36
Appendix 4 Troubleshooting		37

1. General outlines of the communications function

This manual explains the serial communications interface function provided for the TOSVERT VF-nC1 series of industrial inverters.

The TOSVERT VF-nC1 series of inverters can be connected to a computer or a controller (hereinafter referred to as the computer) for data communications via RS232C converter (RS2001Z) or RS485 converter (RS4001Z, RS4002Z). By writing computer programs, you can monitor the operating status of the inverter, control its operation in various ways from the computer, and change and store parameter settings on storage devices.

The communications function allows the transfer of the following information.

- Monitoring function (used to monitor the operating status of the inverter: Output frequency, current, voltage, etc.)
- Command function (used to issue run, stop and other commands to the inverter)
- Parameter function (used to set parameters and read their settings)
- Additional function (Timer function allowing the detection of breaks in cables)

As for data communications codes, the TOSVERT VF-nC1 series of inverters support the binary (HEX) code, in addition to the JIS (ASCII) code. The communications function is designed on the assumption that the JIS (ASCII) code is used for communications between the inverter and the personal computer, and the binary (HEX) code for communications between the inverter and the microcomputer built into the controller. A communication number is used to access the desired data item.

Commands and frequency instructions from the computer have priority (over those from the operation panel or terminal board. To take advantage of this feature, however, you need to enable the mode in which commands and frequency instructions from the computer are valid, regardless of the settings of the command mode selection parameter ($C\ P\ Q\ d$) or that of the frequency setting mode selection parameter ($F\ P\ Q\ d$). For the way of enabling it, see 8, "Commands and monitoring from the computer."

- * The smallest unit of information that computers handle is called a "bit (binary digit)," which represents the two numbers in the binary system: 1 or 0. A group of 16 bits is referred to as a "word," which is the basic unit of information the VF-nC1 series of inverters use for data communications. One word can handle data items of 0 to FFFFH in hexadecimal notation (or 0 to 65535 in decimal notation).

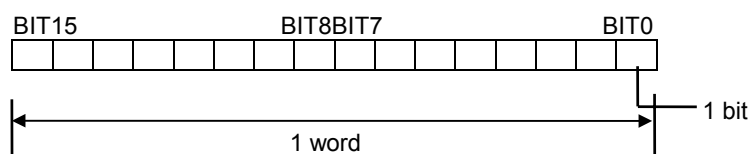

2. Data transmission specifications

Items	Specifications
Transmission scheme	Half-duplex
Synchronization scheme	Start-stop synchronization
Communication baud rate	1200/2400/4800/9600/19200 bps (selectable using a parameter) ^{*1}
Character transmission	<ASCII mode> JIS X 0201 8-bit (ASCII) <Binary mode> Binary codes fixed to 8 bits
Stop bit length	Received by inverter: 1 bit, Sent by inverter: 2 bits ^{*3}
Error detecting scheme	Parity ^{*2} : Even*/odd/non parity (selectable using a parameter) ^{*1} , checksum
Character transmission format	11-bit characters ^{*1} (Stop bit=1, with parity)
Order of bit transmission	Low-order bits transmitted first
Frame length	Variable (to a maximum of 17 bytes)

*: Standard default setting

*1: Changes to the communication baud rate and to the parity setting do not take effect until the inverter is turned back on or reset.

*2: JIS-X-0201 (ANSI)-compliant 8-bit codes are used for all messages transmitted in ASCII mode and vertical (even) parity bits specified by JIS-X-5001 are added to them. These even parity bits can be changed to odd parity bits by changing the parameter setting (a change to the parameter setting does not take effect until the inverter has been reset.)

*3: Here are the default character transmission formats. (Standard default setting)

Characters received by the inverter: 11 bits (1 start bit + 8 bits + 1 parity bit + 1 stop bit) ... Standard default setting

START BIT									PARITY BIT	STOP BIT
-----------	--	--	--	--	--	--	--	--	------------	----------

The inverter receives one stop bit.

(The computer can be set so as to send 1, 1.5 or 2 stop bits.)

Characters sent from the inverter: 12 bits (1 start bit + 8 bits + 1 parity bit + 2 stop bits) ... Standard default setting

START BIT									PARITY BIT	STOP BIT	STOP BIT
-----------	--	--	--	--	--	--	--	--	------------	----------	----------

The inverter sends two stop bits.

(The computer can be set so as to receive 1, 1.5 or 2 stop bits.)

3. Exchange of data between the computer and the inverter

3.1. Brief explanation of the sequence

In communications between the computer and the VF-nC1 (hereinafter referred to as the inverter), the inverter is always placed in wait states and acts as a slave that operates on a request from the computer. A start code is used to automatically identify the mode in which data is transmitted: ASCII mode or binary mode.

- ASCII mode

- (1) In ASCII mode, the start code is “(.”
The inverter rejects all data items entered before the “(.” If two or more “(” are entered, the “(” entered last will be judged valid and all “(” entered before will be ignored. If the “(” is not recognized because of a format error or for any other reason, no error code will be returned since the data is not recognized at all. In such cases, the inverter regards the data received as a transmission error, rejects it and goes back into a start code wait state.
- (2) When an inverter number is added behind the “(,” communications will take place if the number matches up with that assigned to the inverter. If not, the inverter will go back into a start code wait state.
- (3) The inverter stops receiving data on receipt of the CR (carriage return) code inserted in the designated position.
If the size of the data transmitted exceeds the maximum allowable size (17 bytes) or if the CR code cannot be found in the designated position within 0.5 seconds, the inverter will regard the data received as a transmission error and go back into a start code wait state.
- (4) If no communications take place within the time specified using the timer function, the computer will regard it as a communication error and trip the inverter. The timer setting is cleared when the timer is turned on or initialized. For details, see Section 7.1, “Timer function.”
- (5) On executing the command received, the inverter returns data to the computer. For the response time, see Appendix 2, “Response time.”

- Binary mode

- (1) In binary mode, the start code is "2FH(/)."
The inverter rejects all data items entered before the "2FH(/)."
If two or more "2FH(/)" are entered, the "2FH(/)" entered last will be judged valid and all "2FH(/)" entered before will be ignored.
If the "2FH(/)" is not recognized because of a format error or for any other reason, no error code will be returned since the data is not recognized at all. In such cases, the inverter regards the data received as a transmission error, rejects it and goes back into a start code wait state.
- (2) If an inverter number is added behind the "2FH(/)," communication will be established only when the inverter number matches. If not, the inverter will go back into a start code wait state.
- (3) The inverter stops receiving data on receipt of a command and the number of bytes of data specified by the command.
If no command is found in the data received or if the specified number of bytes of data cannot be received within about 0.5 seconds, the inverter will regard the data received as a transmission error and go back into a start code wait state.
- (4) If no communications take place within the time specified using the timer function, the computer will assume that a communication error has occurred and trip the inverter. The timer function is disabled when the inverter is turned on or initialized. For details, see Section 7.1, "Timer function."
- (5) On executing the command received, the inverter returns data to the computer. For the response time, see Appendix 2, "Response time."

- Note

It takes about 1 second for the inverter to complete the initial setup process and to get ready for communications after it has been turned on.
If control power supply is cut off because of a momentary power failure, communications will be interrupted.

3.2. Transmission errors

- Table of error codes

Error name	Description	Error code
Impossible to execute	The command is impossible to execute, though communication was established normally. 1 Writing data into a parameter whose setting cannot be changed during operation (e.g., maximum frequency) *1 2 Writing data into a parameter while “ t y P ” is in progress 3 The maintenance command is issued. *2	0000
Data error	Invalid data is specified.	0001
Communication number error	There is no communication number that matches. Ex.: In the case of (R0))) CR, 0))) is recognized as a communication number.	0002
Command error	The command specified does not exist.	0003 (ASCII mode) No code returned (Binary mode)
Checksum error	The sum differs.	0004
Format error	The data transmission format does not match. 1 One-digit inverter number (ASCII mode) 2 The CR code is found in the designated position. (ASCII mode) Ex.: Communication number of 4 digit or less. In the case of (R11) CR, 11) CR is recognized as a communication number and the CR code is not recognized, with the result that a format error occurs. 3 A code other than the stop code (“ $\text{}$ ”) is entered in the stop code position. 4 The specified number of bytes of data are not received within 0.5 sec.	No code returned
Receiving error	A parity, overrun or framing error has occurred. *3	No code returned

*1: For parameters whose settings cannot be changed during operation, see 11.1, Table of parameters.”

*2: In binary mode, no data will be returned if a command error occurs. When the maintenance command (M) is issued, an impossible-to-execute error occurs and an error code is returned.

*3: Parity error : The parity does not match.
Overrun error : A new data item is entered while the data is being read.
Framing error : The stop bit is placed in the wrong position.

* For the errors with “no code returned” in the above table, no error code is returned to avoid a data crash.

* If the inverter number does not match, no processing will be carried out and no data will be returned, though it is not regarded as an error.

4. Commands

Here are the communication commands available.

Command	Function
R command	Reads the data with the specified communication number.
W command	Writes the data with the specified communication number. (RAM and EEPROM).
P command	Writes the data with the specified communication number. (RAM).
G command	Reads the data with the specified communication number. (For binary mode only. Dummy data is required for this command.)

• W (57H) (RAM^{*1}/EEPROM^{*2} write)

This command is used to write new data into the parameter specified using its communication number. It writes data into the RAM and EEPROM. For parameters whose settings cannot be stored in the EEPROM (e.g., parameter with the communication No. FA00), the W (57H) command writes data into the RAM only. It cannot be used to write data into read-only parameters (e.g., parameter with the communication number FD?? or FE??).

Each time an attempt to write data is made, the inverter checks if the data falls within the specified range. If this check reveals that the data falls outside the specified range, the inverter will reject it and return an error code.

- Ex.: Setting the deceleration time (communication No.: 0010) to 10 sec.

<ASCII mode>

Computer → Inverter

(W00100064)CR

Inverter → Computer

(W00100064)CR

...(10÷0.1=100=0064H)

CR: Carriage return

<Binary mode>

Computer → Inverter

2F 57 00 10 00 64 FA

Inverter → Computer

2F 57 00 10 00 64 FA

...(10÷0.1=100=0064H)

Notice

- ◆ The EEPROM is good for 10,000 times of reprogramming.
Do not write data into the same parameter stored in the EEPROM more than 10,000 times. Unless it is absolutely necessary to store data in the EEPROM, use the P command to write it into the RAM.

• Explanation of terms

*1: The RAM is used to temporarily store inverter operation data. Data stored in the RAM is cleared when the inverter is turned off, and data stored in the EEPROM is copied to the RAM when the inverter is turned back on.

*2: The EEPROM is used to store inverter operation parameter settings, and so on. Data stored in the EEPROM is retained even after the power is turned off, and it is copied to the RAM when the inverter is turned on or reset.

• P (50H) (RAM*1 write)

This command is used to rewrite data into the parameter specified using a communication number. It writes data into the RAM only. It cannot be used to write data into any read-only parameters. Each time an attempt to write data is made, the inverter checks whether the data falls within the specified range. If this check reveals that the data falls outside the range, the inverter will reject it and return an error code.

- Ex.: Entering the emergency stop command (communication No.: FA00) from the computer

<ASCII mode>

<u>Computer → Inverter</u>	<u>Inverter → Computer</u>	
(PFA009000)CR	(PFA009000)CR	...Command priority, emergency stop command

<Binary mode>

<u>Computer → Inverter</u>	<u>Inverter → Computer</u>
2F 50 FA 00 90 00 09	2F 50 FA 00 90 00 09

• R (52H) (Data read)

This command is used to read the setting of the parameter specified using a communication number. (When multiple inverters are operated in binary mode via RS485 converter connected to a two-wire line, the execution of the R command could result in a communication error. To avoid this, use the G command in binary mode when inverters are connected to a two-wire line.)

- Ex.: Monitoring the electric current (communication No.: FE03)

<ASCII mode>

<u>Computer → Inverter</u>	<u>Inverter → Computer</u>	
(RFE03)CR	(RFE03077B)CR	...Current: 1915 / 100 = 19.15%

<Binary mode>

<u>Computer → Inverter</u>	<u>Inverter → Computer</u>
2F 52 FE 03 82	2F 52 FE 03 07 7B 04

Notice

When multiple inverters are operated in binary mode via RS485 converter connected to a two-wire line, use the G command to read data.

• G (47H) (Data read)

This command is used to read the parameter data specified using a communication number. To send this command to an inverter across the two-wire network, 2 bytes of dummy data are needed. This command is available only in binary mode.

- Ex.: Monitoring the electric current (communication No.: FE03)

<u>Computer → Inverter</u>	<u>Inverter → Computer</u>
2F 47 FE 03 00 00 77	2F 47 FE 03 07 7B F9

* In this example, the data 00H sent from the computer to the inverter is dummy data.

5. Data transmission formats

• Note: The term “trip status” used in this manual includes retry waiting status and trip retention status.

5.1. Data transmission formats used in ASCII mode

A communication number is used to specify a data item, all data is written in hexadecimal, and JIS-X-0201 (ASCII (ANSI))-compliant transmission characters are used.

• Computer → VF-nC1

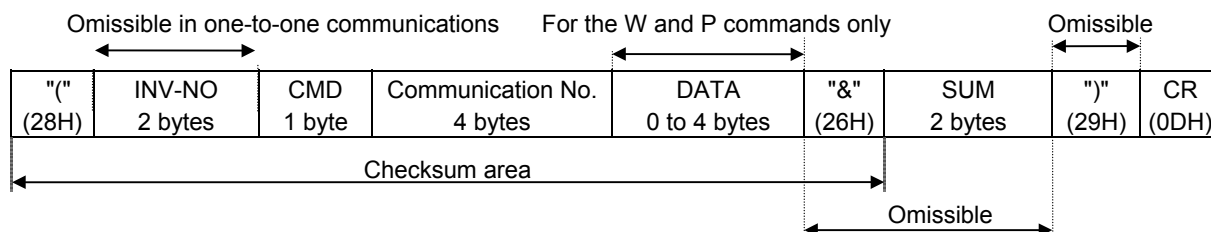

1. "(" (1 byte) : Start code in ASCII mode
2. INV-NO (2 bytes) : Inverter number (Omissible in one-to-one communications) ... 00 (30H, 30H) to 99 (39H, 39h), *(2AH)
The command is executed only when the inverter number matches up with that specified using a parameter.
(When * is specified in broadcast communications, the inverter number is assumed to match if all numbers except * match. When * is specified instead of each digit (two-digit number), all inverters connected are assumed to match.)
If the inverter number does not match or if the inverter number is of one digit, the data will be judged invalid and no data will be returned.
3. CMD (1 byte) : Command (For details, see the table below.)
4. Communication number (4 bytes) : Communication number (See 11, “Parameter data.”)
5. Data (0 to 4 bytes) : Write data (valid for the W and P commands only)
6. "&" (1 byte) : Checksum discrimination code (omissible. When omitting this code, you also need to omit the checksum.)
7. Sum (2 bytes) : Checksum (omissible)
Add the ASCII-coded value of the last two digits (4 bits/digit) of the sum of a series of bits (ASCII codes) from the start code to the checksum discrimination code.
Ex.: (R0000&??) CR
 $28H+52H+30H+30H+30H+30H+30H+26H=160H$
The last two digits represent the checksum. = 60
When omitting the checksum, you also need to omit the checksum discrimination code.
8. ")" (1 byte) : Stop code (omissible)
9. CR (1 byte) : Carriage return code

• Details of commands and data

CMD (1 byte)	Write data (0 to 4 bytes) Hexadecimal number
R (52H): RAM read command	No data
W (57H): RAM/EEPROM write command	Write data (0 to FFFF)
P (50H) RAM write command	Write data (0 to FFFF)

• VF-nC1 → computer

In broadcast communications, if the inverter number does not match or if the inverter number is of one digit, no data will be returned from any inverters except the destination inverter to avoid a data crash.

- Data returned when data is processed normally (ASCII mode)

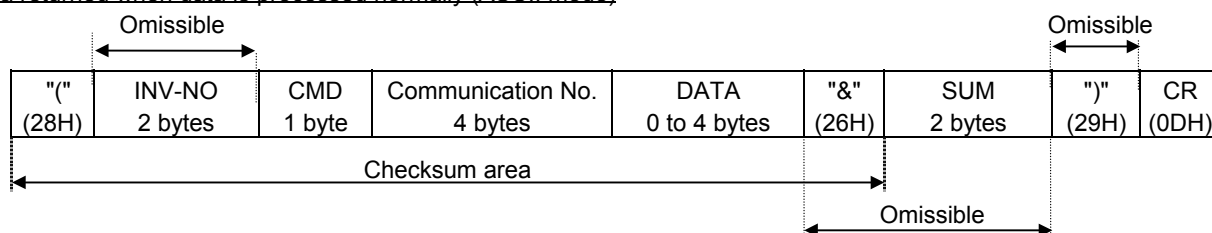

1. "(" (1 byte) : Start code in ASCII mode
2. INV-NO (2 bytes) : Inverter number (omitted if it is not found in the data received) ... 00 (30H, 30H) to 99 (39H, 39H)
 If the inverter number matches up with that specified using a parameter, data will be returned to the computer. In broadcast communications, only the destination inverter (with a number matching up with the smallest effective number) returns data to the computer.
 In broadcast communications, no data is returned from any inverters except the inverter bearing a number that matches up with the smallest effective number.
 Ex.: (*2R0000) CR → (02R00000000) CR
 Data is returned from the inverter with the number 2 only, but no data is returned from inverters with the number 12, 22
3. CMD (1 byte) : Command ... The command is also used for a check when an inverter is tripped.
 Under normal conditions: The uppercase letter R, W or P is returned, depending on the command received: R, W or P command.
 When an inverter is tripped: The lowercase letter r, w or p is returned, depending on the command received: R, W or P command.
 (The command received is returned with 20H added to it.)
4. Communication number (4 bytes) :
 The communication number received is returned.
5. Data (0 to 4 bytes): Data ... The data read in is returned for the R command, while the data received is returned for the W and P commands. If the data received is composed of less than 4 digits, it will be converted into 4-digit data and returned.
 Ex.: (W123412) CR → (W12340012) CR
6. "&" (1 byte) : Checksum discrimination code (omitted if it is not found in the data received)
7. Sum (2 bytes) : Checksum ... Omitted if no checksum discrimination code is found in the data received.
 ASCII-coded value of the last two digits (4 bits/digit) of the sum of a series of bits (ASCII codes) from the start code to the checksum discrimination code.
8. ")" (1 byte) : Stop code (omitted if it is not found in the data received)
9. CR (1 byte) : Carriage return code

- Data returned when data is not processed normally (ASCII mode)

If a communication error occurs, a communication error command (N or n) and an error identification number will be returned to the computer. In broadcast communications, if the inverter number does not match or if the inverter number is of one digit, no data will be returned from any inverters except the destination inverter to avoid a data crash.

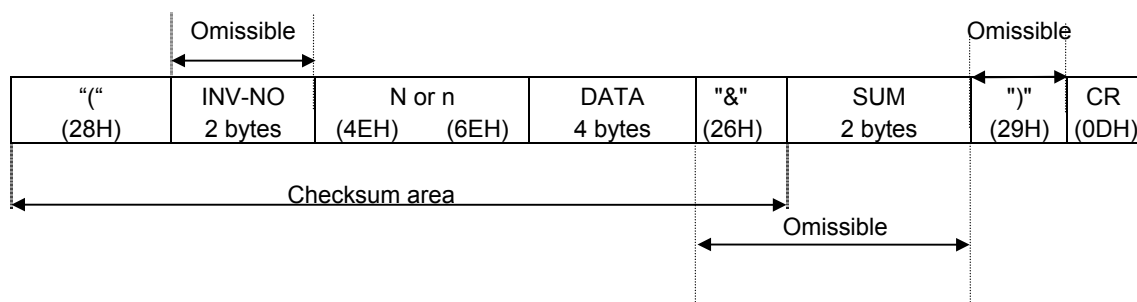

- “((1 byte) : Start code in ASCII mode
- N or n (1 byte) : Communication error command ... The command is also used for a check when an inverter is tripped.
An “N is returned under normal conditions, while an “n” is returned when the inverter is tripped.
- Data (4 bytes) : Error code (0000~0004)
- 0000 ... Impossible to execute (Although communication is established normally, the command cannot be executed because it is to write data into a parameter whose setting cannot be changed during operation (e.g., maximum frequency) or the EEPROM is faulty.)
 - 0001 ... Data error (The data is outside the specified range or it is composed of too many digits.)
 - 0002 ... Communication number error (There is no communication number that matches.)
 - 0003 ... Command error (There is no command that matches.)
 - 0004 ... Checksum error (The checksum result differs.)
-)” (1 byte) : Stop code ... This code is omitted if it is not found in the data received.

• Examples:

- (N0000&5C)_{CR}... Impossible to execute (e.g., a change of maximum frequency data during operation)
- (N0001&5D)_{CR}... Data error (Data is outside the specified range.)
- (N0002&5E)_{CR}... No communication number (There is no communication number that matches.)
- (N0003&5F)_{CR}... There is no command that matches. (Commands other than the R, W and P commands)
(Ex.: L, S, G, a, b, m, r, t, w ...)
- (N0004&60)_{CR}... Checksum error (The checksum result differs.)
- No data returned ... Format error or invalid inverter number
(Ex.: A code other than the stop code (“)) (Ex.: } }) is entered in the stop code position or the CR code was not found within 0.5 sec.)

5.2. Data transmission formats used in binary mode

A communication Number is used to specify a data item, data is written in hexadecimal form, and data in transmission characters are represented by binary codes (HEX codes).

• Computer → VF-nC1 (binary mode)

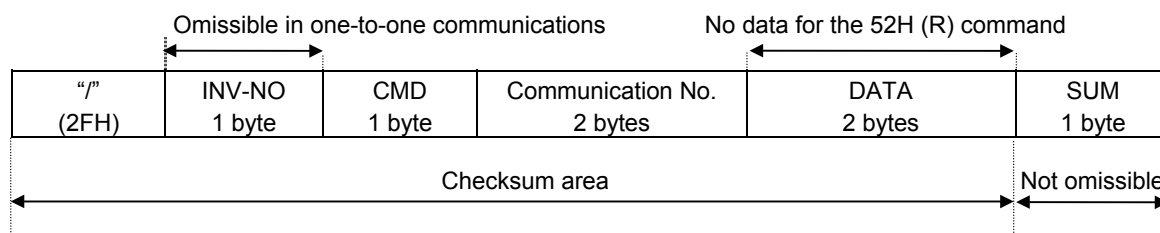

1. 2FH ("2F") (1 byte) : Start code in binary mode
2. INV-NO (1 byte) : Inverter number (Omissible in one-to-one communications) ... 00H to 3EH
The command is executed only when the inverter number matches up with that specified from the operation panel.
If the inverter number does not match, the data will be judged invalid and no data will be returned.
3. CMD (1 byte) : Command (For details, see the table below.)
52H (R) command: The size of the data following CMD is fixed to 3 bytes. (Communication number: 2 bytes, checksum: 1 byte)
57H (W), 50H (P) and 47H (G) commands: The size of the data following CMD is fixed to 5 bytes.
(Communication number: 2 bytes, data: 2 byte, checksum: 1 byte)
Any command other than the above is rejected and no error code is returned.
4. Communication number (2 bytes) : Communication number (See 11, "Parameter data.")
5. Data (2 bytes) : 0000H to FFFFH
57H (W) and 50H (P) commands: Write data (An area check is performed.)
47H (G) command: Dummy data (e.g., 0000) is needed.
52H (R) command: Any data is judged invalid. (No data should be added.)
6. Sum (2 bytes) : Checksum (not omissible) 00H to FFH
Value of the last two digits (1 byte) of the sum of a series of bits (codes) from the start code of the data returned to the data (or to the communication number for the 52H (R) command)
Ex.: 2F 52 00 ?? ... 2FH+52H+00H+00H=81H
The last two digits (??) represent the checksum. = 81

• Details of commands and data

CMD (1 byte)	Write data (2 bytes) Hexadecimal number
52H (R): RAM read command	No data
57H (W): RAM/EEPROM write command	Write data (0000H to FFFFH)
50H (P): RAM write command	Write data (0000H to FFFFH)
47H (G): RAM read command (for two-wire networks)	Dummy data (0000H to FFFFH)

• VF-nC1 → computer (binary mode)

If the inverter number does not match, no data will be returned to avoid a data crash.

- Data returned when data is processed normally (Binary mode)

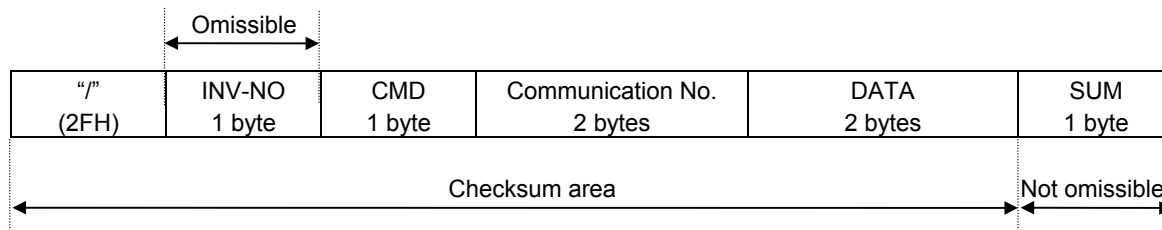

1. 2FH ("2F") (1 byte) : Start code in binary mode
2. INV-NO (1 byte) : Inverter number... 00H to 3EH (The inverter number is omitted if it is not found in the data received.)
If the inverter number matches up with that specified from the operation panel, data will be returned from the inverter. If the inverter number does not match, the data will be judged invalid and no data will be returned.
3. CMD (1 byte) : Command ... The command is also used for a check when the inverter is tripped.
Under normal conditions: 52H (R), 47H (G), 57H (W) or 50H (P) is returned, depending on the command received.
When the inverter is tripped: The lowercase letter 72H (r), 67H (g), 77H (w) or 70H (p) is returned with 20H added to it, depending on the command received.
4. Communication number (2 bytes) : The communication number received is returned.
5. Data (2 bytes) : Data ... 0000H to FFFFH
The data read is returned for the 52H (R) and 47H (G) commands, while the data written is returned for the 57H (W) and 50H (P) commands.
6. Sum (1 byte) : Checksum (not omissible) 00H to FFH
Value of the last two digits (1 byte) of the sum of a series of bits (codes) from the start code to the data.

- Data returned when data is not processed normally (Binary mode)

If a communication error occurs, a communication error command (4EH (N) or 6EH (n)), an error identification number and the checksum will be returned to the computer.

If the inverter number does not match, no data will be returned to avoid a data crash.

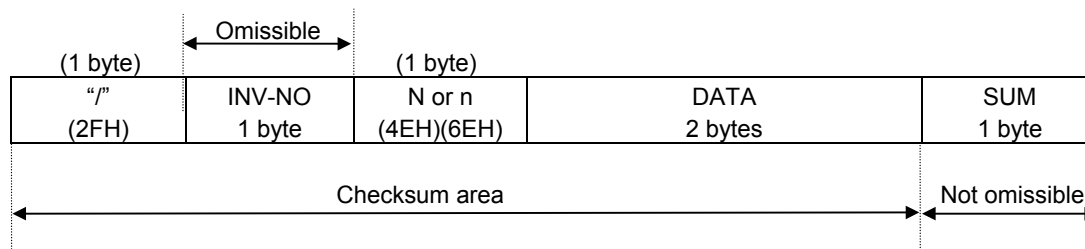

N or n (1 byte) : Communication error command ... This command is also used for a check when the inverter is tripped.

"4EH (N)" is returned under normal conditions, while "6EH (n)" is returned when the inverter is tripped.

Data (2 bytes) : Error code (0000~0004)

0000 ... Impossible to execute (Although communication is established normally, the command cannot be executed because it is to write data into a parameter whose setting cannot be changed during operation (e.g., maximum frequency) or the EEPROM is faulty.)

0001 ... Data error (The data is outside the specified range or it is composed of too many digits.)

0002 ... Communication number error (There is no communication number that matches.)

0004 ... Checksum error (The checksum result differs.)

No code returned : Command error, format error (failure to receive the specified number of bytes within 0.5 seconds, or an parity, overrun or framing error) or the inverter number does not match.

• Examples:

2FH, 4EH, 00H, 00H, 7DH ... Impossible to execute (e.g., a change of maximum frequency data during operation)

2FH, 4EH, 00H, 01H, 7EH ... Data setting error (The data specified falls outside the specified range.)

2FH, 4EH, 00H, 02H, 7FH ... No communication number (There is no communication number that matches.)

2FH, 4EH, 00H, 04H, 81H ... Checksum error (The checksum result differs.)

6. Communications parameters

The settings of communication-related parameters can be changed from the operation panel and the external controller (computer). Note that there are two types of parameters: parameters whose settings take effect immediately after the setting and parameters whose settings do not take effect until the inverter is turned back on or reset.

(1) Communication baud speed (common serial option (logic))

“Parameter title: *F800*, communication No.: 0800”

- Adjustment range: 0 to 4 (default: 3)
0: 1200 bps, 1: 2400 bps, 2: 4800 bps, 3: 9600 bps, 4: 19200 bps
- The same baud speed should be specified for the computer and every inverter on the network.
- The setting of this parameter does not take effect until the power is turned back on.

(2) Parity bit

“Parameter title: *F801*, communication No.: 0801”

- Adjustment range: 0 to 2 (default: 1)
0: Non parity, 1: Even parity, 2: Odd parity
- The same parity should be specified for the computer and every inverter on the network.
- The setting of this parameter does not take effect until the power is turned back on.

(3) Inverter number

“Parameter title: *F802*, communication No.: 0802”

→ This parameter is used to specify a name (number) for each inverter.

- Adjustment range: 0 to 99 (default: 0)
(In binary mode, only numbers between 0 and 62 can be assigned.)
- The same inverter number should never be assigned to different inverters on the same network.
- The setting of this parameter takes effect immediately.
- If the number of an inverter does not match up with that stored in the computer, data from the inverter will be rejected.

(4) Time-out period

“Parameter title: *F803* communication No.: 0803”

→ This parameter is used to specify a time period for each inverter to check if the inverter has received data at least once within the specified time. For details, see 7.1, “Timer function.”

- Adjustment range: 0 to 100 (default: 0)
0: Timer function OFF, 1 to 100: Time-out period (1 = Approx. 1 second)
- The setting of this parameter takes effect immediately.

(5) Free notes

“Parameter title: *F880*, communication No.: 0880”

→ This parameter allows you to write any data, e.g., the serial number of each inverter or parameter information, which does not affect the operation of the inverter.

- Adjustment range: 0 to 65535 (0000H to FFFFH)
- The setting of this parameter takes effect immediately.

7.Functions

7.1.Timer function

The timer function is used to detect breaks in cables during communications and to trip an inverter (E r r 5) if the inverter has received no data within the time specified using this function. If the inverter number does not match or if a format error occurs, preventing the inverter from returning data to the computer, this function will assume that the inverter has not received any data.

• How to set the timer

The communication error trip time parameter (*F 8 0 3*) is set to 0 (timer off) by default.

* Timer adjustment range

About 1 sec. (01H) to about 100 sec. (64H) / Timer off (0H)

• How to start the timer

If the timer is set from the operation panel, it will start automatically the instant when communication is established for the first time after the setting.

If the timer is set from the computer, it will start automatically the instant when communication is established after the setting.

If the timer setting is stored in the EEPROM, the timer will start when communication is established for the first time after the power has been turned on.

Note that, if the inverter number does not match or if a format error occurs, preventing the inverter from returning data, the timer function will assume that no communication has taken place and will not start.

• How to disable the timer

To disable the timer, set its parameter to 0.

Ex.: To disable the timer function from the computer (To store the timer setting in the EEPROM)

Computer → Inverter

(W08030)CR

Inverter → Computer

(W08030000)CR

... Sets the timer parameter to 0 to disable it.

• Timer

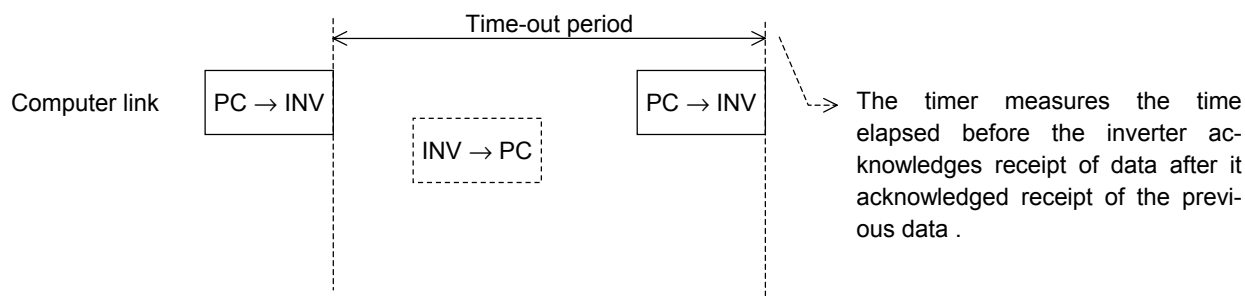

7.2. Broadcast communications function

The broadcast communications function enables the computer to issue a command simultaneously to (or to write data into) multiple inverters on the network.

This function is available in ASCII mode only. It supports the data write commands (W and P), but not the data read commands (R and D). Also, it supports up to 100 inverters on the network, i.e., inverters bearing a number between 0 and 99 (00H to 63H). To avoid a data crash, it returns data to specific inverters only.

To send data to multiple inverters at one time, the host computer adds an asterisk (*) to the number of each destination inverter. This asterisk serves as a wildcard that stand for any number between 0 and 9. Once data has been received, the asterisk in each inverter number is replaced by 0, and the inverter whose number matches up with that number returns data to the computer on behalf of the other inverters.

- “Overall” broadcast communications (ASCII mode only)

If you enter two asterisks (**) in the inverter number position of the data transmission format, the computer will send the data simultaneously to all inverters (with an inverter number between 0 and 99 (00 to 63H)) on the network.

<Inverter that returns data to the computer>

Data is returned from the inverter bearing the inverter number 00 only.

If you do not want inverters to return data, do not assign the number 00 to any inverter on the network.

- “Group” broadcast communications (ASCII mode only)

If you put *? in the inverter number position of the data transmission format, data will be sent simultaneously to all inverters bearing a number whose digit in the ten’s place in decimal notation is ?.

If you put ?* in the inverter number position of the data transmission format, the data will be sent simultaneously to all inverters bearing a number whose digit in the one’s place in decimal notation is ?.

(?: Any number between 0 and 9.)

<Inverter that returns data to the computer>

Data is returned only from the inverter bearing the smallest number in the same group of inverters (i.e., inverter whose number in the position of * is 0).

If you do not want inverters to return data to the computer, do not assign a number having a 0 in the position of * to any inverter on the network.)

- Examples of broadcast communications

Ex: Set the frequency setting for communication to 60Hz.

1 Host computer → Multiple inverters: broadcast communications

** (Broadcast communication symbol) + data to transmit

Example of transmission of data from computer to inverter: (**W12341234)_{CR}

Example of data returned from inverter to computer: (00W12341234)_{CR}

Data is returned from the inverter numbered 00 only, while commands are issued to all inverters connected to the network.

2 Host computer → A specific group of inverters: group communications

* (Group number (inverter number)) + data to transmit

Example of transmission of data from computer to inverters: (*9W12341234)_{CR}

Example of data returned from inverter to computer: (09W12341234)_{CR}

Data is returned only the inverter numbered 09 only, while commands are issued to a maximum of 10 inverters bearing the number 09, 19, 29, 39, ... or 99.

• An example of system configuration (schematic diagram)

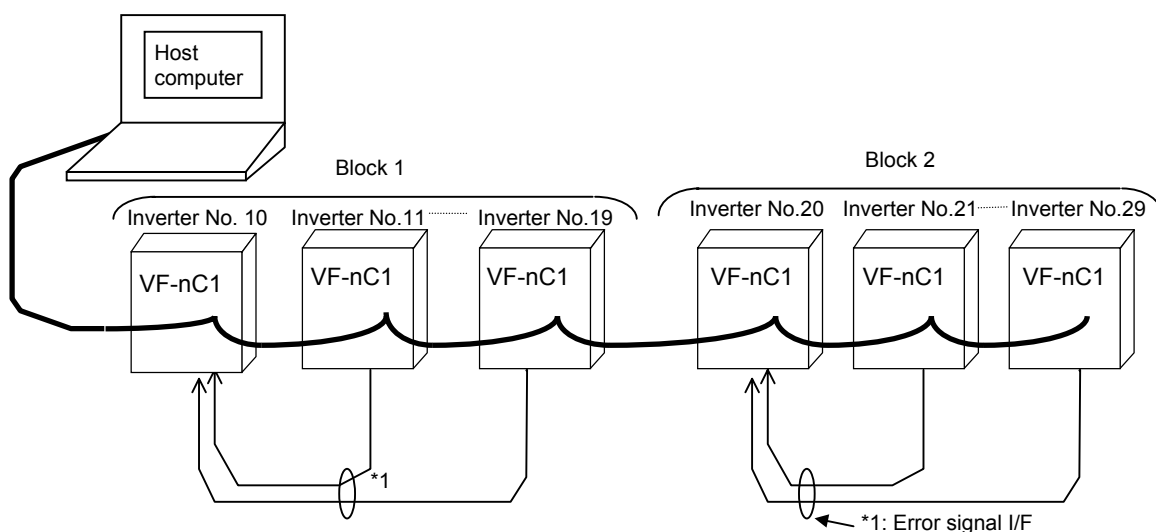

In broadcast communications, only the representative inverter in each block returns data to the host computer. However, you can make the representative inverter in each block report the occurrence of a problem in the block. To do so, follow these steps.

Set the timer function so that, if a time-out occurs, the inverter will trip (Ex.: $F 803=3$ (sec)), set the output terminal selection parameter (FL) so that trip information will be output through the output terminal ($F 132=10$), and set the input terminal selection parameter (F) of the representative inverter in each block to "external input trip (emergency stop)" ($F 111=11$). Then, connect the input terminal (F) of the representative inverter to the FL terminal of each of the other inverters in the same block. In this setting, if an inverter trips, the representative inverter will come to an emergency stop, and as a result it will report the occurrence of a problem in its block to the computer. (If the representative inverter returns a lowercase letter in response to a command from the computer, the computer will judge that a problem has arisen in an inverter.) To examine details on the problem that has arisen, the host computer accesses each individual inverter, specifying its communication number. To make the computer issue a command to all inverters in block 1 or block 2 shown in the figure above, specify "1*" or "2*", respectively. In this system, inverter No. 10 will return data to the computer if a problem arises in block 1, or inverter No. 20 if a problem arises in block 2. For overall broadcast communications, specify "***", in which case the inverter with the communication number "00" will return data to the computer.

In this example, if you want the computer to maintain communications without bringing a representative inverter to an emergency stop, set its input terminal selection parameter to "disabled" ($F 111=0$) but not to "external input trip (emergency stop)." This setting causes the host computer to check the setting of the input terminal information parameter (communication No.: FE06) of the representative inverter, and as a result enables the computer to detect the occurrence of a problem.

8. Commands and monitoring from the computer

Across the network, instructions (commands and frequency instructions) can be sent to each inverter and the operating status of each inverter can be monitored.

8.1. Communication commands (commands from the computer)

• Communication command (Communication No.: FA00)

The VF-nC1 series of inverters give priority to commands and frequency instructions entered from the computer across the network. For this reason, they have the mode of enabling commands and frequency instructions entered across the network, regardless of the setting of the command mode selection parameter (CnCd) enabling commands from the operation panel or terminal board, or the setting the frequency setting mode selection parameter (FnCd) enabling frequency instructions entered using the internal potentiometer, operation panel or terminal board.

To enable communication commands (commands from the computer), set bit 15 of the communication No. FA00 parameter to 1 (enabled), and to enable frequency instructions from the computer, set bit 14 of the communication No. FA00 parameter to 1 (enabled). Once priority is given to commands and frequency instructions from the computer, they have priority until they are disabled manually (bit 15 of the communication No. FA00 parameter: 0), or until the inverter is turned off or reset, or until the inverter is reset to the standard default settings (tYF).

Table 1 Data composition of communication commands (communication No.: FA00)

bit	Specifications	0	1	S7	S9	nC1	Remarks
0	Preset speed operation frequencies 1	Preset speed operation is disabled or preset speed operation frequencies (1-15) are set by specifying bits for preset speed operation frequencies 1-4. (0000: Preset speed operation OFF, 001-1111: Setting of preset speed operation frequencies (1-15))		•	•	•	Preset speed operation can be disabled or a preset speed operation frequencies (1-15) can be specified by combining 4 bits variously.
1	Preset speed operation frequencies 2						
2	Preset speed operation frequencies 3						
3	Preset speed operation frequencies 4						
4	Motor selection (1 or 2) (THR 2 selection)	Motor 1 (THR 1)	Motor2 (THR2)	×	•	•	THR1 : PT=set value, vL, vb, tHr THR2 : PT=0, F170, F172, F173
5	PI control	Normal operation	PI OFF	×	•	•	
6	Acceleration/deceleration pattern selection (1 or 2) (AD2 selection)	Acceleration/deceleration pattern 1 (AD1)	Acceleration/deceleration pattern 2 (AD2)	•	•	•	AD1 : ACC, DEC, AD2 : F500, F501
7	DC braking	OFF	Forced DC braking	•	•	•	
8	Jog run	OFF	Jog run	•	•	•	
9	Forward/reverse run selection	Forward run	Reverse run	•	•	•	
10	Run/stop	Stop	Run	•	•	•	
11	Coast stop command	Standby	Coast stop	•	•	•	
12	Emergency stop	OFF	Emergency stop	•	•	•	"E" trip
13	Fault reset	OFF	Reset	•	•	•	No data is returned from the inverter.
14	Frequency priority selection	OFF	Enabled	•	•	•	Enabled regardless of the setting of FnCd
15	Command priority selection	OFF	Enabled	•	•	•	Enabled regardless of the setting of CnCd

Note: For the reset command, no data will be returned.

Ex.: Forward run: (PFA008400) CR

1 is specified for bit 15 (communication command: enabled) and bit 10 (operation command).

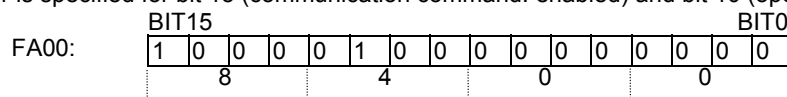

Ex.: Reverse run: (PFA008600) CR, (PFA00C600) CR

8600H : To disable frequency instructions from the computer

C600H : To enable also frequency instructions from the computer

• Frequency setting from the computer (communication No.: FA01)

This parameter is used to set an inverter operation frequency from the computer. Frequency instructions from the computer are valid only when the frequency setting mode selection parameter is so set.

To enable frequency instructions from the computer, set the speed command selection parameter (*F_{NO}d*) to "serial communication" (communication No. 0004: 3) or set the communication command to "command priority" (bit 14 of the communication No. FA00 parameter: 1 (enabled)). If the mode in which frequency instructions from the computer are valid is selected, frequency instructions from the computer will become valid, regardless of the setting of *F_{NO}d*. Once this mode is selected, it is enabled until it is disabled manually (0), or until the inverter is turned off or reset, or until the inverter is rest to its standard default settings (*U_{SP}*). (The settings of the FA00 and FA01 cannot be stored in the EEPROM. Therefore, they are cleared when the inverter is turned off or reset.)

The communication No. FA01 parameter is used to set to set operation frequencies from the computer. Note that the FA01 needs to be set in hexadecimal (0.01 Hz).

Ex.: Instruction for an operation frequency of 80Hz (PFA011F40) CR

$$80\text{Hz} = 80 / 0.01 = 8000 = 1\text{F40H}$$

8.2. Monitoring from the computer

This section explains how to monitor the operating status of the inverter from the computer.

• Monitoring of the operation frequency from the computer (FE00, FD00)

Operation frequency (frequency immediately before the occurrence of a trip):

Communication No. FE00 (Minimum unit: 0.01 Hz)

Operation frequency (current frequency): Communication No. FD00 (Minimum unit: 0.01 Hz)

Ex.: Monitoring of operation frequency (during 50 Hz operation) ... (1388H = 5000d, 5000 x 0.1 = 50 Hz)

Computer → Inverter Inverter → Computer
(RFD00)_{CR} (RFD001388)_{CR}

• Inverter operating status (FE01, FD01)

Operating status (status immediately before the occurrence of a trip):

Communication No. FE01

Operating status (current status): Communication No. FD01

Table 2 Data composition of inverter operating status (FE00/FD00) (*: FD01 supports the VF-nC1 and later models.)

Bit	Specifications	0	1	S7	S9	nC1	Remarks
0	Failure FL	No output	Output in progress	-	-	•	
1	Failure	Not tripped	Tripped	-	-	•	Trip statuses include $r \bar{t} r \bar{y}$ and trip retention status.
2	Alarm	No alarm	Alarm issued	-	-	•	
3	Reserved	-	-	-	-	-	
4	Motor section (1 or 2) (THR 2 selection)	Motor 1 (THR 1)	Motor 2 (THR 2)	-	•	•	THR1: PT=set value, vL, vb, Thr THR2:PT=0, F170, F172, F173
5	PI control OFF	PI control permitted	PI control prohibited	-	•	•	
6	Acceleration/deceleration pattern selection (1 or 2) (AD2 selection)	Acceleration/deceleration pattern 1 (AD 1)	Acceleration/deceleration pattern 2 (AD 2)	•	•	•	AD1 :ACC, DEC, AD2 :F500, F501
7	DC braking	OFF	Forced DC braking	•	•	•	
8	Jog run	OFF	Jog run	•	•	•	
9	Forward/reverse run	Forward run	Reverse run	•	•	•	
10	Run/stop	Stop	Run	•	•	•	
11	Coast stop (ST=OFF)	ST=ON	ST=OFF	-	•	•	
12	Emergency stop	Not emergency stop status	Emergency stop status	-	•	•	
13	Standby ST=ON	Start-up process	Standby	-	-	•	Standby: Initialization completed, not failure stop status, not alarm stop status (MOFF, LL forced stop or forced stop due to a momentary power failure), ST=ON, and RUN=ON
14	Standby	Start-up process	Standby	-	-	•	Standby: Initialization completed, not failure stop status, and not alarm stop status (MOFF, LL forced stop or forced stop due to a momentary power failure)
15	Reserved	-	-	-	-	-	

• Input terminal board status (FE06)

The input terminal function selection parameter is used to select a function for each input terminal. When monitoring the operating status, check what function is assigned to each internal terminal.

Data composition of input terminal board (FE06)

Bit	Terminal name (extended)	Function (parameter title)	0	1
0	F	Input terminal selection 1 ($F 111$)	OFF	ON
1	R	Input terminal selection 2 ($F 112$)	OFF	ON
2	S1	Input terminal selection 3 ($F 113$)	OFF	ON
3	S2	Input terminal selection 4 ($F 114$)	OFF	ON
4	V/S3 *1	Input terminal selection 5 ($F 115$)	OFF	ON
5 ~ 15	-	-	-	-

*1: Valid only when $F 109 = 2$ (contact input)

Ex.: FE06 data when the F and S1 terminals are ON: 0005H

FE06:	0	0	0	0	0	0	0	0	0	0	0	0	0	0	1	0	1
	0				0				0				5				

• Output terminal board status (FE07)

The output terminal function selection parameter is used to select a function for each output terminal. When monitoring the operating status, check what function is assigned to each output terminal.

Data composition of output terminal board (FE07)

Bit	Terminal name	Function (parameter title)	0	1
0	FM/OUT *2	Output terminal selection1 ($F 130$)	OFF	ON
1	-	-	-	-
2	FL	Output terminal selection3 ($F 132$)	OFF	ON
3 ~ 15	-	-	-	-

*2: Enable by $F 75L = - 1$ (Open collector output) setting.

Ex.: FE07 data when both the FM/OUT and FL terminals are ON: 0005H

FE07:	0	0	0	0	0	0	0	0	0	0	0	0	0	0	1	0	1
	0				0				0				5				

• Alarm code monitor (FC901)

Bit	Specifications	0	1	Remarks (Code displayed on the panel)
0	Over-current alarm	Normal	Alarm issued	<i>C</i>
1	Inverter overload alarm	Normal	Alarm issued	<i>L</i>
2	Motor overload alarm	Normal	Alarm issued	<i>L</i>
3	Overheat alarm	Normal	Alarm issued	<i>H</i>
4	Overvoltage alarm	Normal	Alarm issued	<i>P</i>
5	Main circuit undervoltage alarm	Normal	Alarm issued	<i>NOFF</i>
6	(Reserved)	-	-	-
7	(Reserved)	-	-	-
8	Over-torque alarm	Normal	Alarm issued	-
9 ~ 15	(Reserved)	-	-	-

• Trip code monitor (current status: FC90: historic records: FE10 to FE13)

Code	Data (hexadecimal number)	Data (decimal number)	Description
<i>nErr</i>	0	0	No error
<i>OC1</i>	1	1	Over-current during acceleration
<i>OC2</i>	2	2	Over-current during deceleration
<i>OC3</i>	3	3	Over-current during constant speed operation
<i>OCL</i>	4	4	Over-current in load at startup
<i>OCRA</i>	5	5	Short circuit in arm
<i>EPH1</i>	8	8	Input phase failure
<i>EPH0</i>	9	9	Output phase failure
<i>OP1</i>	A	10	Overvoltage during acceleration
<i>OP2</i>	B	11	Overvoltage during deceleration
<i>OP3</i>	C	12	Overvoltage during constant speed operation
<i>OL1</i>	D	13	Over-LOAD in inverter
<i>OL2</i>	E	14	Over-LOAD in motor
<i>OH</i>	10	16	Overheat trip
<i>E</i>	11	17	Emergency stop
<i>EEP1</i>	12	18	EEPROM fault 1 (writing error)
<i>EEP2</i>	13	19	EEPROM fault 2 (reading error)
<i>EEP3</i>	14	20	EEPROM fault 3 (internal fault)
<i>Err2</i>	15	21	RAM fault
<i>Err3</i>	16	22	ROM fault
<i>Err4</i>	17	23	CPU fault
<i>Err5</i>	18	24	Communication error trip
<i>Err7</i>	1A	26	Current detector fault
<i>UP1</i>	1E	30	Trip due to undervoltage in main circuit
<i>EF2</i>	22	34	Ground fault trip (hardware detection)
<i>OC1P</i>	25	37	Overheat of an element during acceleration
<i>OC2P</i>	26	38	Overheat of an element during deceleration
<i>OC3P</i>	27	39	Overheat of an element during constant speed operation
<i>E-18</i>	32	50	Break in an analog signal cable
<i>E-19</i>	33	51	CPU fault
<i>E-20</i>	34	52	Excess torque boost
<i>E-21</i>	35	53	CPU fault
<i>E-50</i>	52	82	Sink-to-source logic switching check

E - 5 1	53	83	Source-to-since switching check
---------	----	----	---------------------------------

• Inverter model (capacity) code (FB05)

Model	Data (hexadecimal number)	Data (decimal number)
VFNC1-2001P	00	0
VFNC1-2002P	01	1
VFNC1-2004P	02	2
VFNC1-2007P	04	4
VFNC1-2015P	06	6
VFNC1-2022P	07	7
VFNC1S-1001P	0C	12
VFNC1S-1002P	0D	13
VFNC1S-1004P	0E	14
VFNC1S-1007P	0F	15
VFNC1S-2002P	11	17
VFNC1S-2004P	12	18
VFNC1S-2007P	14	20
VFNC1S-2015P	16	22
VFNC1S-2022P	17	23
VFNC1S-2002PL	19	25
VFNC1S-2004PL	1A	26
VFNC1S-2007PL	1C	28
VFNC1S-2015PL	1E	30
VFNC1S-2022PL	1F	31

9. Examples of the use of communication commands

Here are some examples of the use of communications commands provided for the VF-nC1 series of inverters.

Inverter numbers and checksum used in ASCII mode are omitted from these examples.

• Examples of communications

- To run the motor in forward direction with the frequency set to 60 Hz from the computer

<ASCII mode>

<u>Computer → Inverter</u>	<u>Inverter → Computer</u>
(PFA011770)CR	(PFA011770)CR ...Set the operation frequency to 60 Hz. (60 / 0.01 Hz = 6000 = 1770H)
(PFA00C400)CR	(PFA00C400)CR ...Set to "forward run" with commands and frequency instructions from the computer enabled.

<Binary mode>

<u>Computer → Inverter</u>	<u>Inverter → Computer</u>
2F 50 FA 01 17 70 01	2F 50 FA 01 17 70 01
2F 50 FA 00 C4 00 3D	2F 50 FA 00 C4 00 3D

- To monitor the operation frequency (during 60 Hz operation)

<ASCII mode>

<u>Computer → Inverter</u>	<u>Inverter → Computer</u>
(RFD00)CR	(RFD001770)CR ...Set the operation frequency to 60 Hz. (60÷0.01Hz=6000=1770H)

<Binary mode>

<u>Computer → Inverter</u>	<u>Inverter → Computer</u>
2F 52 FD 00 7E	2F 52 FD 00 17 70 05

- To monitor the status of the inverter

<ASCII mode>

<u>Computer → Inverter</u>	<u>Inverter → Computer</u>
(RFD01)CR	(rFD010003)CR ...For details on statuses, see 8.2, "Monitoring from the computer." (stop status, FL output status, trip status (r command))

<Binary mode>

<u>Computer → Inverter</u>	<u>Inverter → Computer</u>
2F 52 FD 01 7F	2F 72 FD 01 00 03 A2

- To check the trip code (when the inverter is tripped because of $\overline{E} r r \overline{5}$)

...For details on trip codes, see "Trip code monitor" in 8.2, "Monitoring from the computer." (18H = 24d " $\overline{E} r r \overline{5}$ " trip status)

<ASCII mode>

<u>Computer → Inverter</u>	<u>Inverter → Computer</u>
(RFC90)CR	(rFC900018)CR

<Binary mode>

<u>Computer → Inverter</u>	<u>Inverter → Computer</u>
2F 52 FC 90 0D	2F 72 FC 90 00 18 45

10. Examples of RS232C communication programs

Ex. 1: BASIC program for monitoring the operation frequency continuously (RS232C, ASCII mode)
(Toshiba version of Advanced BASIC-86 Ver. 3.01.05J)

◇ Monitoring the operation frequency continuously

1) Examples of programs

10 OPEN "COM1:9600,E,8,1" AS #1	---	9600 baud, even parity, 8-bit length, 1 stop bit
20 A\$="FE00"	---	Specifies the communication number for monitoring the operation frequency.
30 PRINT #1, "("+R"+A\$+"")	---	Transmits data to the inverter. Note: The carriage return code is added automatically.
40 INPUT#1,B\$	---	Receives data returned from the inverter.
50 AAA\$="&H"+MID\$(B\$,7,4)	---	Extracts only data items from the data returned.
60 F\$=LEFT\$(STR\$(VAL(AAA\$)/100),6)	---	Converts data into decimal form.
70 PRINT " Operation frequency =",F\$+"Hz"	---	Displays the operation frequency.
80 GOTO 20	---	Repeats.

2) Examples of program execution results (stop command issued during 80 Hz operation)

```
Operation frequency = 80 Hz ...
Operation frequency = 79.95Hz
      :
      :
Operation frequency = 0Hz
```

Ex. 2: BASIC program for executing an input command with checksum (RS232C, ASCII mode)
(Toshiba version of Advanced BASIC-86 Ver. 3.01.05J)

◇ Checking if the maximum frequency setting has been changed correctly

1) Examples of programs

10 OPEN "COM1:9600,E,8,1" AS #1	---	9600 baud, even parity, 8-bit length, 1 stop bit
20 INPUT"Send Data=";A\$	---	Reads in data to be sent to the inverter.
30 S\$="("+A\$+"&"	---	Adds "(" and "&" to the read data in.
40 S=0		Calculates the number of bits (checksum).
50 L=LEN(S\$)		
60 FOR I=1 TO L		
70 S=S+ASC(MID\$(S\$,I,1))		
80 NEXT I		
90 CHS\$=RIGHT\$(HEX\$(S),2)		
100 PRINT #1, "("+A\$+"&"+"CHS\$+"")	---	Sends the data including the checksum result to the inverter.
110 INPUT #1,B\$	---	Receives data returned from the inverter.
120 PRINT "Receive data=" ;B\$	---	Displays the data received.
130 GOTO 20	---	Repeats.

2) Examples of program execution results

Send Data=? R0011	---	Reads the maximum frequency (0011).
Receive Data= (R00111F40&3D)	---	1F40 (Maximum frequency: 80 Hz)
Send Data=? W00111770	---	Changes the maximum frequency to 60 Hz (1770).
Receive Data= (W00111770&36)		
Send Data=? R0011	---	Reads the maximum frequency (0011).
Receive Data= (R00111770&31)	---	1770 (Maximum frequency: 60 Hz)

Ex. 3 BASIC program for communication tests (RS232C, ASCII mode)
 (Toshiba version of Advanced BASIC-86 Ver. 3.01.05J)

◇ Accessing a parameter (with error code.)

1) Examples of programs

```

100 INPUT "Baud rate=9600/4800/2400/1200";SPEED$
                                     ---- Selects a baud rate.
110 INPUT "Parity=even(E)/odd(O)";PARITY$
                                     ---- Selects parity.
120 OPEN "COM1:"+SPEED$+", "+PARITY$+",8,1"AS #1
130 INPUT "Send data";B$             ---- Enters a command.
140 PRINT #1,B$
150 C$=""
160 T=TIMER
170 COUNT=(TIMER-T)
180 IF COUNT >3 THEN 270
190 IF COUNT <0 THEN T=TIMER        ---- Prevents an increase in the number of digits.
200 IF LOC(1)= 0 THEN A$="":GOTO 220
210 A$=INPUT$(1,#1)
220 IF A$ <>CHR$(13) THEN 240        ---- Carriage return
230 GOTO 290                         (CR) to finish reading in.
240 IF A$="" THEN 160
250 C$=C$+A$
260 GOTO 160
270 COLOR @0,7:PRINT "!!! There is no data to return. !!! ";COLOR @7,0:PRINT
280 GOTO 130                          ---- Repeats.
290 PRINT A$;
300 C$=C$+A$
310 PRINT "Return data=";c$;
320 GOTO 130                          ---- Repeats.

```

2) Examples of program execution results (In this example, the inverter number is 00.)

```

Baud rate=9600/4800/2400? 9600      ---- Selects 9600 baud.
Parity=even(E)/odd(O)? E            ---- Select E (even parity).
Send data? (00R0011)                ---- Carries out test communications.
Return data= (00R00111770)
Send data? ()                        ---- Error
!!! There is no data to return. !!!  ---- No data is returned.
Send data? (R0011)
Return data= (R00111770)
Send data?
:
:

```

11. Parameter data

This Chapter explains the parameters provided for the VF-nC1 series of inverters. When using the communications function, use the tables of parameters shown below to check communication numbers, upper and lower limits, and so on. For the default setting of each parameter and details on each data item, refer to the instruction manual for your VF-nC1 inverter.

11.1. Table of parameters

Each table of parameters shown below is composed of the following items:

- (1) Communication number ... Refers to the number assigned to each parameter for communications purposes. A communication number is needed to specify a parameter from the computer.
- (2) Title ... Refers to codes displayed on the inverter's operation panel. "-" in the title column indicates that no code is displayed on the operation panel.
- (3) Upper and lower limits ... Expressed in hexadecimal (or decimal for numbers in ()).
- (4) Unit ... Refers to the basic unit of each data item. For example, the basic unit of acceleration time is 0.1 seconds. To set an acceleration time of 10 seconds from the computer, 0064 (100) needs to be entered.
- (5) Writing during operation ... The parameters marked with X cannot be changed while the inverter is in operation.

• Basic parameters (Group No.: 00)

Communication No.	Title	Function	Upper limit HEX(DEC)	Lower limit HEX(DEC)	Unit	Writing during operation
0003	<i>CND</i>	Command mode selection	1	0	-	×
0004	<i>FND</i>	Frequency setting mode selection	4	0	-	×
0005	<i>FNSL</i>	FM/OUT terminal functions selection	6	FFFF(-1)	-	○
0006	<i>FN</i>	Meter adjustment	FF(255)	0	-	○
0007	<i>LYP</i>	Standard setting mode selection	5	0	-	×
0008	<i>FR</i>	Forward/reverse selection (Operation panel)	1	0	-	○
0009	<i>ACC</i>	Acceleration time 1	7530(30000)	1	0.1s	○
0010	<i>DEC</i>	Deceleration time 1	7530(30000)	1	0.1s	○
0011	<i>FH</i>	Maximum frequency	4E20(20000)	BB8(3000)	0.01Hz	×
0012	<i>UL</i>	Upper limit frequency	<i>FH</i>	32(50)	0.01Hz	○
0013	<i>LL</i>	Lower limit frequency	<i>UL</i>	0	0.01Hz	○
0014	<i>UL</i>	Base frequency 1	4E20(20000)	9C4(2500)	0.01Hz	×
0015	<i>Pt</i>	V/F control mode selection	3	0	-	×
0016	<i>ub</i>	Torque boost 1	12C(300)	0	0.1%	○
0600	<i>THR</i>	Motor thermal protection level 1	64(100)	1E(30)	1%	○
0017	<i>OLN</i>	Electronic thermal protection characteristics	7	0	-	○
0018	<i>Sr1</i>	Preset speed operation frequencies 1	<i>UL</i>	<i>LL</i>	0.01Hz	○
0019	<i>Sr2</i>	Preset speed operation frequencies 2	<i>UL</i>	<i>LL</i>	0.01Hz	○
0020	<i>Sr3</i>	Preset speed operation frequencies 3	<i>UL</i>	<i>LL</i>	0.01Hz	○
0021	<i>Sr4</i>	Preset speed operation frequencies 4	<i>UL</i>	<i>LL</i>	0.01Hz	○
0022	<i>Sr5</i>	Preset speed operation frequencies 5	<i>UL</i>	<i>LL</i>	0.01Hz	○
0023	<i>Sr6</i>	Preset speed operation frequencies 6	<i>UL</i>	<i>LL</i>	0.01Hz	○
0024	<i>Sr7</i>	Preset speed operation frequencies 7	<i>UL</i>	<i>LL</i>	0.01Hz	○

• Extended parameters (Input/output parameters. Group No.: 01)

Communication No.	Title	Function	Upper limit HEX(DEC)	Lower limit HEX(DEC)	Unit	Writing during operation
0100	<i>F 100</i>	Low-speed signal output frequency	<i>FH</i>	3C(60)	0.01Hz	○
0101	<i>F 101</i>	Speed reach setting frequency	<i>FH</i>	0	0.01Hz	○
0109	<i>F 109</i>	Analog/logic input function selection (VI/S3 terminal)	2	0	-	×
0110	<i>F 110</i>	Always-active function selection	39(57)	0	-	×
0111	<i>F 111</i>	Input terminal selection 1 (F)	39(57)	0	-	×
0112	<i>F 112</i>	Input terminal selection 2 (R)	39(57)	0	-	×
0113	<i>F 113</i>	Input terminal selection 3 (S1)	39(57)	0	-	×
0114	<i>F 114</i>	Input terminal selection 4 (S2)	39(57)	0	-	×
0115	<i>F 115</i>	Input terminal selection 5 (VI/S3)	11(17)	5	-	×
0127	<i>F 127</i>	Sink/source logic switching	200	0	-	×
0130	<i>F 130</i>	Output terminal selection 1 (OUT/FM)	D(13)	0	-	×
0132	<i>F 132</i>	Output terminal selection 3 (FL)	D(13)	0	-	×
0170	<i>F 170</i>	Base frequency 2	4E20(20000)	9C4(2500)	0.01Hz	×
0171	<i>F 171</i>	Base frequency voltage 2	1388(5000)	1F4(500)	0.1V	×
0172	<i>F 172</i>	Torque boost 2	12C(300)	0	0.1%	○
0173	<i>F 173</i>	Motor electronic-thermal protection level 2	64(100)	1E(30)	1%	○

• Extended parameters (Frequency parameters. Group No.: 02)

Communication No.	Title	Function	Upper limit HEX(DEC)	Lower limit HEX(DEC)	Unit	Writing during operation
0201	<i>F 201</i>	VI/S3 input point 1 setting	64(100)	0	1%	○
0202	<i>F 202</i>	VI/S3 input point 1 frequency	4E20(20000)	0	0.01Hz	○
0203	<i>F 203</i>	VI/S3 input point 2 setting	64(100)	0	1%	○
0204	<i>F 204</i>	VI/S3 input point 2 frequency	4E20(20000)	0	0.01Hz	○
0240	<i>F 240</i>	Starting frequency setting	3E8(1000)	32(50)	0.01Hz	○
0241	<i>F 241</i>	Operation starting frequency	<i>FH</i>	0	0.01Hz	○
0242	<i>F 242</i>	Operation starting frequency hysteresis	<i>FH</i>	0	0.01Hz	○
0250	<i>F 250</i>	DC braking starting frequency	<i>FH</i>	0	0.01Hz	○
0251	<i>F 251</i>	DC braking current	64(100)	0	1%	×
0252	<i>F 252</i>	DC braking time	C8(200)	0	0.1s	○
0270	<i>F 270</i>	Jumping frequency 1	<i>FH</i>	0	0.01Hz	○
0271	<i>F 271</i>	Jumping width 1	BB8(3000)	0	0.01Hz	○
0287	<i>F 287</i>	Preset speed operation frequencies 8	<i>UL</i>	<i>LL</i>	0.01Hz	○
0288	<i>F 288</i>	Preset speed operation frequencies 9	<i>UL</i>	<i>LL</i>	0.01Hz	○
0289	<i>F 289</i>	Preset speed operation frequencies 10	<i>UL</i>	<i>LL</i>	0.01Hz	○
0290	<i>F 290</i>	Preset speed operation frequencies 11	<i>UL</i>	<i>LL</i>	0.01Hz	○
0291	<i>F 291</i>	Preset speed operation frequencies 12	<i>UL</i>	<i>LL</i>	0.01Hz	○
0292	<i>F 292</i>	Preset speed operation frequencies 13	<i>UL</i>	<i>LL</i>	0.01Hz	○
0293	<i>F 293</i>	Preset speed operation frequencies 14	<i>UL</i>	<i>LL</i>	0.01Hz	○
0294	<i>F 294</i>	Preset speed operation frequencies 15	<i>UL</i>	<i>LL</i>	0.01Hz	○

• Extended parameters (Operation mode parameters. Group No.: 03)

Communication No.	Title	Function	Upper limit HEX(DEC)	Lower limit HEX(DEC)	Unit	Writing during operation
0300	<i>F300</i>	PWM carrier frequency	6	0	-	×
0301	<i>F301</i>	Auto-restart control selection	3	0	-	×
0302	<i>F302</i>	Regenerative power ride-through control	2	0	-	×
0303	<i>F303</i>	Retry selection (number of times)	A(10)	0	1 time	○
0305	<i>F305</i>	Overvoltage stall operation	2	0	-	×
0360	<i>F360</i>	PI control	1	0	-	○
0362	<i>F362</i>	Proportional gain	2710(10000)	1	0.01	○
0363	<i>F363</i>	Integral gain	2710(10000)	1	0.01	○

• Extended parameters (Torque boost parameters. Group No.: 04)

Communication No.	Title	Function	Upper limit HEX(DEC)	Lower limit HEX(DEC)	Unit	Writing during operation
0401	<i>F401</i>	Slip frequency gain	96(150)	0	1%	×
0409	<i>F409</i>	Base frequency voltage	1388(5000)	1f4(500)	0.1V	×
0415	<i>F415</i>	Motor rated current	1f4(500)	1	0.1A	×
0416	<i>F416</i>	Motor No-load current	50(80)	1E(30)	1%	×
0417	<i>F417</i>	Motor rated rotational speed	2EE0(12000)	64(100)	min ⁻¹	×
0418	<i>F418</i>	Speed control gain	64(100)	1	1%	×
0419	<i>F419</i>	Speed control stable coefficient	64(100)	1	1%	×

• Extended parameters (Acceleration/deceleration time parameters. Group No.: 05)

Communication No.	Title	Function	Upper limit HEX(DEC)	Lower limit HEX(DEC)	Unit	Writing during operation
0500	<i>F500</i>	Acceleration time 2	7530(30000)	1	0.1s	○
0501	<i>F501</i>	Deceleration time 2	7530(30000)	1	0.1s	○
0505	<i>F505</i>	Acceleration/deceleration 1 and 2 switching frequency	UL	0	0.01Hz	○

• Extended parameters (Protection parameters. Group No.: 06)

Communication No.	Title	Function	Upper limit HEX(DEC)	Lower limit HEX(DEC)	Unit	Writing during operation
0601	<i>F601</i>	Stall prevention level	C8(200)	1E(30)	1%	×
0602	<i>F602</i>	Inverter trip retention selection	1	0	-	○
0603	<i>F603</i>	External input trip stop mode selection	2	0	-	×
0605	<i>F605</i>	Output phase failure detection mode selection	2	0	-	○
0607	<i>F607</i>	Motor overload withstanding time	320(800)	A(10)	sec	○
0608	<i>F608</i>	Input phase failure detection mode selection	1	0	-	×
0616	<i>F616</i>	Over-torque alarm level	C8(200)	0	%	○
0618	<i>F618</i>	Over-torque detection time	64(100)	0	sec	○
0627	<i>F627</i>	Undervoltage trip selection	2	0	-	×
0633	<i>F633</i>	Analog signal cable break detection	64(100)	0	%	○

• Extended parameters (Operation panel parameters. Group No.: 07)

Communication No.	Title	Function	Upper limit HEX(DEC)	Lower limit HEX(DEC)	Unit	Writing during operation
0700	<i>F700</i>	Prohibition of change of parameter settings	7	0	-	○
0701	<i>F701</i>	Unit selection	3	0	-	○
0702	<i>F702</i>	Free unit selection	4E20(20000)	1	-	○
0710	<i>F710</i>	Standard monitor display selection	2	0	-	○

• Extended parameters (Communication parameters. Group No.: 08)

Communication No.	Title	Function	Upper limit HEX(DEC)	Lower limit HEX(DEC)	Unit	Writing during operation
0800	<i>F800</i>	Communication baud speed	4	0	-	○
0801	<i>F801</i>	Parity	2	0	-	○
0802	<i>F802</i>	Inverter number	63(99)	0	-	○
0803	<i>F803</i>	Communication error trip time	64(100)	0	sec	○
0880	<i>F880</i>	Free notes	FFFF(65535)	0	-	○

• Command parameters (Group No.: FA)

Communication No.	Title	Function	Upper limit HEX(DEC)	Lower limit HEX(DEC)	Unit	Writing during operation
FA00	-	Command from the computer ^{*3}	FFFF(65535)	0	-	○
FA01	-	Operation frequency command (computer) ^{*3}	<i>FH</i>	0	0.01Hz	○
FA03	-	Operation frequency command (operation panel) ^{*4}	<i>UL</i>	<i>LL</i>	0.01Hz	○

*3: The settings of these parameters are stored in the RAM only. To write them into the EEPROM, use the P command.

These parameters do not function unless the command mode selection parameter or the frequency setting mode selection parameters are enabled. For the ways of enabling them, see 8.1, "Commands from the computer."

*4: For the VF-S7 series of inverters, FA02 is assigned to the operation panel frequency command parameter.

- Monitor parameters * These parameters are read-only (monitor-only) parameters.

Communication No.	Title	Function	Unit	Remarks
FC90	-	Trip code	-	See 8.2.
FC91	-	Alarm code	-	See 8.2.
FD00	-	Operation frequency (current frequency)	0.01Hz	
FD01	-	Inverter status (current status)	-	See 8.2.
FD06	-	Input terminal information (current information)	-	See 8.2.
FD07	-	Output terminal information (current information)	-	See 8.2.
FE00	-	Operation frequency ^{*5}	0.01Hz	
FE01	-	Inverter status ^{*5}	-	See 8.2.
FE02	-	Operation frequency command (actual instruction) ^{*5}	0.01Hz	
FE03	-	Electric current display ^{*5}	0.01%	
FE04	-	Voltage in DC section ^{*5}	0.01%	
FE05	-	Output voltage ^{*5}	0.01%	
FE06	-	Input terminal information ^{*5}	-	See 8.2.
FE07	-	Output terminal information ^{*5}	-	See 8.2.
FE08	-	CPU version	-	
FE09	-	EEPROM version	-	
FE10	-	Past trip 1	-	See 8.2.
FE11	-	Past trip 2	-	See 8.2.
FE12	-	Past trip 3	-	See 8.2.
FE13	-	Past trip 4	-	See 8.2.
FE14	-	Cumulative operation time	1H	
FE15	-	Primary frequency (compensated frequency) ^{*5}	0.01Hz	
FE16	-	Estimated motor operation frequency ^{*5}	0.01Hz	
FE20	-	Torque current ^{*5}	0.01%	
FE21	-	Excitation current ^{*5}	0.01%	
FE22	-	Analog (VI) input frequency ^{*5}	0.01Hz	
FE26	-	Electronic-thermal load factor ^{*5}	1%	
FE27	-	Inverter load factor monitor ^{*5}	1%	
FE30	-	Output power monitor ^{*5}	1%	
FE35	-	Analog (VI) converted value monitor ^{*5} 10-bit resolution (data range: 0 to 1023)	-	
FE70	-	Rated current	0.1A	
FE71	-	Rated voltage	0.1V	
FE73	-	CPU version 2	-	

*5: If a trip occurs, data immediately before its occurrence is displayed.

Appendix 1 Table of data codes

- JIS (ASCII) codes

Higher order Lower order	0	1	2	3	4	5	6	7
0	NUL	TC ₇ (DLE)	(SP)	0	@	P	,	p
1	TC ₁ (SOH)	DC ₁	!	1	A	Q	a	q
2	TC ₂ (STX)	DC ₂	"	2	B	R	b	r
3	TC ₃ (ETX)	DC ₃	#	3	C	S	c	s
4	TC ₄ (EOT)	DC ₄	\$	4	D	T	d	t
5	TC ₅ (ENQ)	TC ₈ (NAK)	%	5	E	U	e	u
6	TC ₆ (ACK)	TC ₉ (SYN)	&	6	F	V	f	v
7	BEL	TC ₁₀ (ETB)		7	G	W	g	w
8	FE ₀ (BS)	CAN	(8	H	X	h	x
9	FE ₁ (HT)	EM)	9	I	Y	i	y
A	FE ₂ (LF)	SUB	*	:	J	Z	j	z
B	FE ₃ (VT)	ESC	+	;	K	[k	{
C	FE ₄ (FF)	IS ₄ (FS)	,	<	L	¥	l	
D	FE ₅ (CR)	IS ₃ (GS)	-	=	M]	m	}
E	SO	IS ₂ (RS)	.	>	N	^	n	
F	SI	IS ₁ (US)	/	?	O	—	o	DEL

CR: Carriage return

Ex.: Code 41 = Character A

Appendix 2 Response time

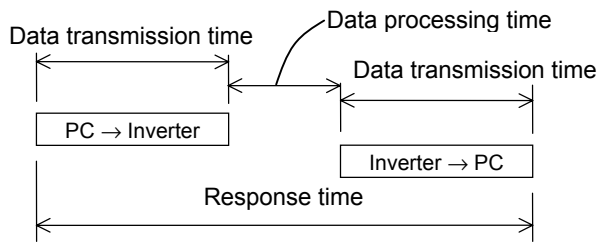

• Data transmission time

$$\text{Data transmission time} = \frac{1}{\text{baud rate}} \times \text{number of bytes transmitted} \times \text{number of bits}$$

* Number of bits = start bit + data frame length + parity bit + stop bit

* Minimum number of bits = 1 + 8 + 0 + 1 = 10 bits

* Maximum number of bits = 1 + 8 + 1 + 2 = 12 bits

<An example of the calculation of the transmission time: 19200 bps, 8 bytes, 11 bits>

$$\text{Data transmission time} = \frac{1}{19200} \times 8 \times 11 = 1 = 4.6$$

• Data processing time

Data processing time: 34 to 143 ms (varies depending on the number of bytes transmitted and the data transmission timing)

PC → INV \ INV → PC	8 bytes of data or less	16 bytes of data or less	17 bytes
8 bytes of data or less	34 ~ 78 ms	46 ~ 98 ms	-
16 bytes of data or less	47 ~ 91 ms	59 ~ 111 ms	71 ~ 130 ms
17 bytes	60 ~ 104 ms	72 ~ 124 ms	84 ~ 143 ms

- In binary mode, the data processing time is 78 ms at the maximum.

- In ASCII mode, the data processing time is 111 ms at the maximum when 16 bytes of data or less are transmitted, or 143 ms at the maximum when 17 bytes of data with the maximum frame length (with an inverter number, checksum data and a stop code) are transmitted.

<Ex.: To set the maximum frequency parameter (communication No.: 0011) of the specified inverter to 60 Hz>

Computer → Inverter Inverter → Computer
 (00W00111770)cr (00W00111770)cr ... 60Hz=1770H

* In this example, the data is less than 16 bytes and therefore the data processing time is 111 ms at the maximum.

Appendix 3 Compatibility with the communications function of the VF-S7

To provide consistency in communications procedures, the communications function of the VF-nC1 series of inverters has been designed based on the protocols used for the Toshiba VF-S7 series of inverters. With regard to compatibility, however, VF-S7 users should check the items described below before using the communications function of their inverters.

- To VF-S7 inverter users:

Some parameters of the VF-S7 are different from those of the VF-nC1 in function or adjustment range (upper and lower limits), even though they have the same title or the same communication number. So, when accessing a parameter, consult the VF-S7 inverter's instruction manual to see if the parameter is identical to the corresponding parameter of the VF-nC1. If the parameter differs, modify the computer program to suit your inverter. To avoid hazards, never copy parameters from one model of inverter to another.

- Comparison of communication-related items

The table below gives a comparison of communication-related items to be kept in mind when replacing VF-S7 inverters with VF-nC1 inverters or when connecting VF-S7 inverters and VF-nC1 inverters to the same network. It does not cover any items common to the VF-S7 and VF-nC1 series of inverters.

Item	Model	VF-S7	VF-nC1	Reference
Communication baud rate		1200/2400/4800/9600 bps (fixed to 1200 bps for the VF-S7e)	1200/2400/4800/9600/19200bps	Chapter 2 Chapter 6
Designation of inverter numbers		* ASCII mode: Decimal number, Adjustment range: 00 to 63 * Binary mode: Hexadecimal number, Adjustment range: 00H to 3FH (00 to 63)	* ASCII mode: Decimal number, Adjustment range: 00 to 99 * Binary mode: Hexadecimal number, Adjustment range: 00H to 3EH (00 to 62)	Chapter 5
Broadcast communications function		Not provided	Available only in ASCII mode	
Reset command		When the reset command is issued, the transmission of return data from the inverter may be broken off, depending on the reset timing.	When the reset command is issued, no data will be returned from the inverter.	Chapter 4
Response time		About 8 ms (This is only standard time, not guarantee time.)	34 ~ 143 ms	Appendix 2

Notice

- ◆ Do not use communications programs written for another series of inverters. Even though parameters have the same title and the same communication number, they may be different in function. When using a parameter, always check its specifications in the instruction manual for your inverter. If the specifications of the parameter differ, modify the computer program to suit your inverter.
- ◆ To avoid hazards, do not copy parameters from one model of inverter to another. Even though parameters have the same titles and communication numbers, they may be different in function.

Appendix 4 Troubleshooting

If a problem arises, diagnose it in accordance with the following table before making a service call. If the problem cannot be solved by any remedy described in the table or if no remedy to the problem is specified in the table, contact your Toshiba dealer.

Problem	Remedies	Reference
Communications will not take place.	<ul style="list-style-type: none"> - Are both the computer and the inverter turned on? - Are all cables connected correctly and securely? - Are the same baud rate, parity and bit length set for every unit on the network? 	Chapter 6
An error code is returned.	<ul style="list-style-type: none"> - Is the data transmission format correct? - Does the data written fall within the specified range? 	Chapter 5 Chapter 11
The trip $\overline{ERR5}$ occurs.	<ul style="list-style-type: none"> - Check the cable connection and the timer setting. 	Section 7.1
Frequency instructions from the computer have no effect.	<ul style="list-style-type: none"> - Is the frequency setting mode selection parameter set to "computer"? 	Chapter 8.1
Commands, including the run and stop commands, from the computer have no effect.	<ul style="list-style-type: none"> - Is the command mode selection parameter set to "computer"? 	Chapter 8.1
A change to a parameter does not take effect.	Some communications-related parameters do not take effect until the inverter is reset. To make them take effect, turn the inverter off temporarily, then turn it back on.	Chapter 6
The setting of a parameter was changed, but it returns to its original setting when the inverter is turned off.	Use the W command to write data into the EEPROM. If you write data into the RAM only, using the P command, it will be cleared when the inverter is reset.	Chapter 4