

RS485 Converter Unit Instruction Manual

RS4002Z-0

NOTE

1. Make sure that this instruction manual is delivered to the end user of the RS485 converter unit.
2. Read this manual before installing or operating the RS485 Converter unit.
And keep it in a safe place for reference.

Toshiba Schneider Inverter Corporation





© TOSHIBA SCHNEIDER INVERTER CORPORATION 2001

All Rights Reserved.





Safety precautions

On the inverter and in its instruction manual, important information is contained for preventing injuries to users and damages to assets and for proper use of the device. Read the instruction manual attached to the inverter along with this instruction manual for completely understanding the safety precautions and adhere to the contents of these manuals.



Handling in general

|  Danger | |
|---|---|
|  Never Disassemble | <ul style="list-style-type: none"> ▼ Never disassemble, modify or repair the product. Disassembling the product could cause electric shocks, fire or injuries. For repairs, call your agency. |
|  Prohibited | <ul style="list-style-type: none"> Do not remove connectors when the power is on. It could lead to electric shocks. ▼ Do not put or insert foreign objects such as waste cable, bars, or wires into the product. It could lead to electric shocks or fire. ▼ Do not splash water over the product. It could lead to electric shocks or fire. |
|  Mandatory | <ul style="list-style-type: none"> ▼ Wiring should be conducted after turning the inverter power off. ▼ Turn off the power immediately in case any abnormalities such as smokes, smells or abnormal noise are found. Neglect of these conditions could lead to fire. For repairs, call your agency. |

Transportation and installation

|  Danger | |
|---|---|
|  Prohibited | <ul style="list-style-type: none"> ▼ Do not install or operate the inverter if it is damaged or any part is missing from it. Operating the inverter in a defective condition could lead to electric shocks or fire. For repairs, call your agency. ▼ Do not put any inflammable material near the product. It could catch fire if the product sparks because of a breakdown and the like. ▼ Do not install the product where it could be splashed with water and the like. It could lead to electric shocks or fire. |
|  Mandatory | <ul style="list-style-type: none"> ▼ The product must be used under environmental conditions prescribed in this instruction manual. Using the product under conditions not specified by the instruction manual could lead to breakdown. |
|  Cautions | |
|  Prohibited | <ul style="list-style-type: none"> ▼ Do not install the product in any place subject to vibrations or it could fall. Otherwise it can cause injury to people. |



Wiring

|  Danger | |
|---|---|
|  Mandatory | <p>Turn off input power before wiring.</p> <p>Wait at least ten minutes and check to make sure that the charge lamp (on the inverter main unit) is no longer lit.</p> <p>Tighten the screws on the terminal board to specified torque.</p> <p>If the screws are not tightened to the specified torque, it could lead to fire.</p> |

About operation

|  Danger | |
|---|--|
|  Prohibited | <ul style="list-style-type: none"> ▼ Do not wipe the body with a wet cloth. It could lead to electric shocks. ▼ Do not pull on the cable It could cause damage or error. |

About disposal of the product

|  Warning | |
|--|--|
|  Mandatory | <p>Dispose of the product as an industrial waste.</p> <p>Unless it is disposed of as an industrial waste, it will become risks for human injury.</p> |

Notes on use

| NOTES | |
|--------------|---|
| | <ul style="list-style-type: none"> ▼ Avoid installation locations that may be subjected to rapid changes in ambient temperature or/and humidity. ▼ Route the transmission cable separate from the inverter input/output power wiring. When disconnecting connection cable, make sure to hold its connector with care not to give unreasonable stress to the cable and the unit. Separate the SHIELD terminal ground of the RS485 converter unit from those of the inverter and the motor. It could cause malfunction due to noise. ▼ Since connectors of optional cables have locking pawls for disconnection prevention at the inverter and the Option Unit, disconnect such a connector while pressing the pawl by finger for unlocking. ▼ Mount the Option Unit securely on the panel, otherwise it could fall and cause malfunction or breakdown ▼ Connect an electromagnetic contactor or the like between the inverter and the power source to secure external control of emergency stop of operation. |

Table of Contents

| | |
|--|----|
| 1. OVERVIEW | 5 |
| 2. COMMUNICATION SPECIFICATIONS | 5 |
| 3. NAMES AND FUNCTIONS OF MAIN PARTS | 6 |
| 4. CONNECTION WITH EQUIPMENT | 7 |
| 4.1. Installation of RS485 converter unit | 8 |
| 4.2. Wiring of inverter cables | 8 |
| 4.3. Wiring of RS485 communication cable | 9 |
| 4.3.1. Connection of RS485 communication cable | 10 |
| 5. DIMENSIONS | 11 |
| 6. COMMUNICATION PARAMETERS | 12 |
| 7. SPECIFICATIONS | 12 |
| 8. WARRANTY | 12 |

1. Overview

By using RS485 Converter Unit, a network can be constructed that allows communication between a host computer or PLC etc. and multiple inverter units.

A maximum of 32 Option Units can be connected on the same network. And 8 inverters can be connected to one RS485 Converter Unit. A maximum of 256 inverters* can be connected on the same network.

*Only when communicating between inverters, and the number is limited when communicating with individual inverters depending on the function of each inverter.)

<System configuration>

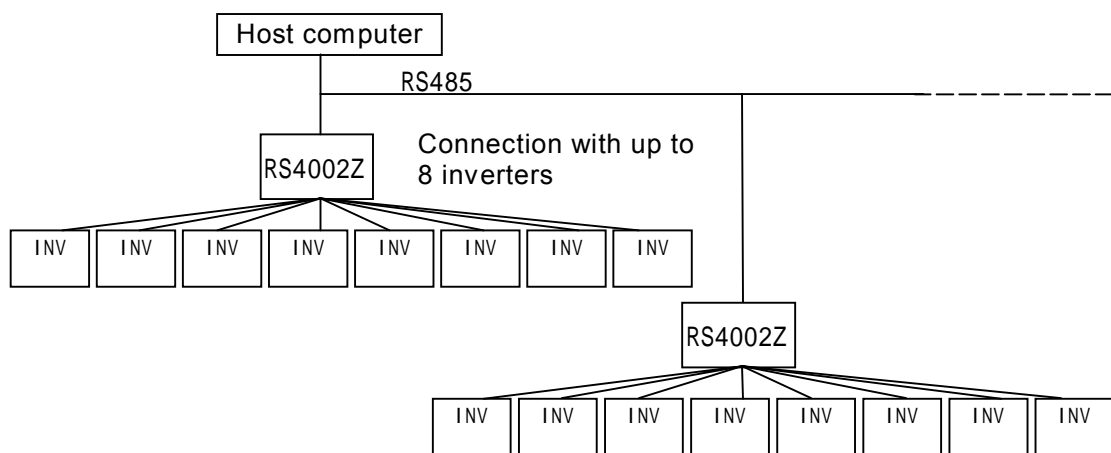

(*) A maximum number of inverters connectable is $32 \times 8 = 256$. This number applies only to communications between inverters. Up to 248 units can be connected in broadcast communication. In the case of individual communications, the number is limited by the function of each inverter.

Check the transmission format specification of the inverter to be used.

■ Example of VF-A7 series inverter

- Communication between inverters: $32 \times 8 = 256$ units max
- Broadcast communication: $31 \times 8 = 248$ units max
(31 units because of 1 unit needed for PC.)
- Individual communication (ASCII mode): 100 units max
- Individual communication (binary mode): 64 units max

2. Communication specifications

| Item | Specifications |
|---|---|
| Interface | Conforming to EIA RS485 standard |
| Configuration | 4-wire/2-wire, bus type (A terminating resistor is required at both ends of the system) |
| Transmission method | Semi-duplex |
| Communication Distance | 1,000m maximum |
| Number of option units connectable | 32 units maximum (31 units when PC is connected) |
| Number of inverters connectable per option unit | 8 units maximum |
| Number of inverters on the Same Network | 256 units maximum () |
| Communication Line Isolation | Not isolated |
| Communication Speed | 1200/2400/4800/9600/19200 baud selectable (parameter and switch selection) |
| Bit length | 11 or 12 bits (switch selectable) |

3. Names and functions of main parts

The outline view of the RS485 converter unit and the names of each part

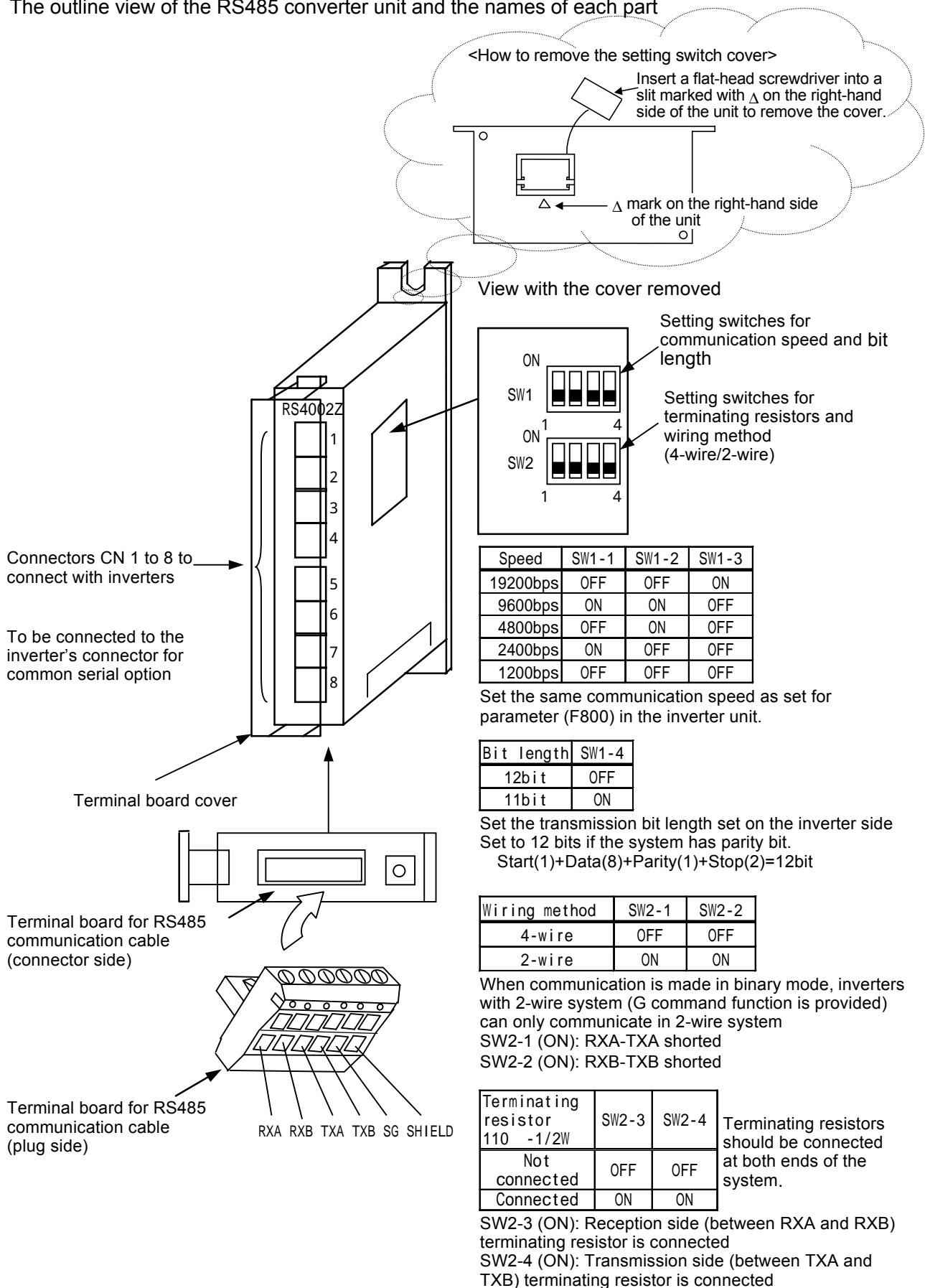

4. Connection with equipment

Connect the RS485 converter unit with inverters as follows:

- (1) Turn off input power of the inverter and wait at least ten minutes and check to make sure that the charge lamp is no longer lit.
- (2) Set the communication speed, bit length and wiring method (4-wire or 2-wire) using the switches of the RS485 converter unit. Furthermore, when communicating in the binary mode, the inverters conforming to 2-wire system (G command function is provided) can only be communicated in 2-wire system. When using the binary method but without the 2-wire system function, use 4-wire system.

Use the same communication speed, bit length and wiring method for RS485 converter units that are connected in the same network. (Refer to page 6.)

- (3) Connect terminating resistor in both ends of units. The RS485 Option Unit has internal terminating resistor. Set SW2-3 and SW2-4 to ON to connect these terminating resistors. (Refer to page 6.)
- (4) Install the RS485 Option Unit on a metal panel. (Refer to page 8.)
- (5) Connect the RS485 communication cable to the removable terminal block. (Refer to page 9 and page 10.)

Be sure not to short any wires.

- (6) Connect the shield of the twisted pair cable to the SHIELD terminal on each RS485 Option Unit, and make the ground connection. Do not connect the shield of the twisted pair cable to a power ground or any other noise-producing ground connection
- (7) Insert the removable terminal block back into the RS485 Option Unit.
- (8) Connect the communication connectors (CN1 to 8) of the RS485 Option Unit to the inverter's common serial option (communication) connector of the with the optional cable.
- (9) Turn on the power of the inverter
- (10) Set the communication parameters of the inverter. (Refer to page 12.)
- (11) Turn off the power of the inverter and then turn it on again if the parameters have been changed.

* Transmission/Reception is automatically changed in the RS485 converter unit.

This unit can be used only in semi-duplex transmission.

* Observe the following when data is transmitted from PC to the inverter.

To prevent a possible error due to the difference of communication speed between the equipment, provide a time interval for one bit data length or more from the time data is received before starting data to the inverter.

Time for one bit data = $1 \div \text{communication speed}$

(Example) in the case of 19200bps: $1 \div 19200 = 52\mu\text{s}$

4.1. Installation of RS485 converter unit

Install the unit on the panel of a cabinet etc. and secure the unit with two M4 screws.

Install the cables (connection cables between inverters and converter unit, and RS485 communication cable). Separate the cables at least 20 cm from the main circuit cables. Do not bundle them together.

Attach the cables to the wall inside the cabinet etc.

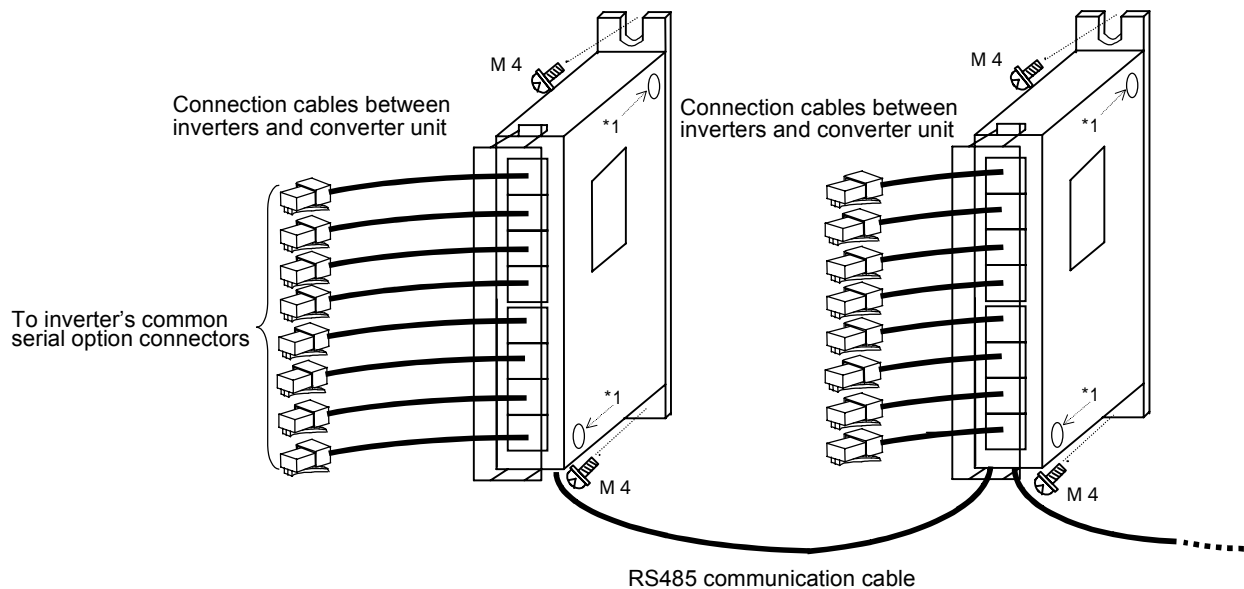

*1 Unit interconnection screw hole: not used for this option.

4.2. Wiring of inverter cables

Observe the following when wiring is carried out:

- ◆ Connect the inverter's common serial option connector and this unit's inverter connection connector with optional connection cable.

Connection cable: CAB0011 (1m), CAB0013 (3m), CAB0015 (5m)

- ◆ Separate the connection cables at least 20 cm from the main circuit cables. Do not bundle them together.

Wiring them close to each other may lead to malfunction due to noise.

4.3. Wiring of RS485 communication cable

Observe the following when wiring is carried out:

- ◆ Use shielded twist cables of 0.2 to 2.5 mm² for communication cables. Select wire size depending on the transmission distance referring to the table below.

Use the same type of wires inside the system.

Recommended transmission cable

| Item | Specification | | |
|--------------------|---|----------------|---------------------------------|
| Transmission cable | Shielded twist cable | | |
| Connection method | Twist RXA and RXB wires and twist TXA and TXB. Twist RXA (or TXA) and RXB (or TXB) wires for 2-wire system. Note: Connect a terminating resistor at both ends of wires. | | |
| Cable length | Cable type | Cable length | Recommended maker |
| | CPEV-CU 1.2 mm ϕ (single wire) | 1000 m or less | SHOWA WIRE & CABLE Co. Ltd., |
| | KMPEV-SB 0.75 mm ² (twisted wire) | 700 m or less | |
| | KMPEV-SB 0.5 mm ² (twisted wire) | 500 m or less | |
| | GECLS-9004 AWG24 (0.2 mm ²) (single wire) | 300 m or less | |

- ◆ Remove the sheath of wire about 10 mm from the end of wire.
- ◆ Use a flat-head screwdriver with the blade thickness of 0.6 mm and width of 3.5 mm.
- ◆ Screw tightening torque for the terminal board screws should be 0.5 to 0.6 N·m
- ◆ Separate the communication cables at least 20 cm from the main circuit cables. Do not bundle them together.

Wiring them close to each other may lead to malfunction due to noise.

4.3.1. Connection of RS485 communication cable

Refer to the following together with items described above as to cable connection to terminal block.

- Do not connect the ground of shield to power ground such as that of the inverter.
- Separate the communication cables at least 200mm from the main circuit cables.

Removable terminal block

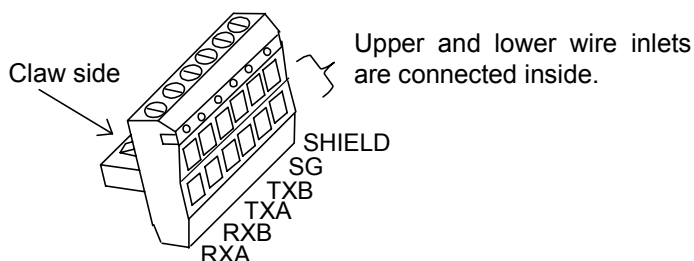

| Signal name | Name |
|-------------|-----------------------|
| RXA | Receiving data (+) |
| RXB | Receiving data (-) |
| TXA | Transmitting data (+) |
| TXB | Transmitting data (-) |
| SG | Signal ground |
| SHIELD | Shield |

Maker : Phoenix Contact
Type : TMSTBP 2.5/6-ST-5.08

■ Connection example for 4-wire system

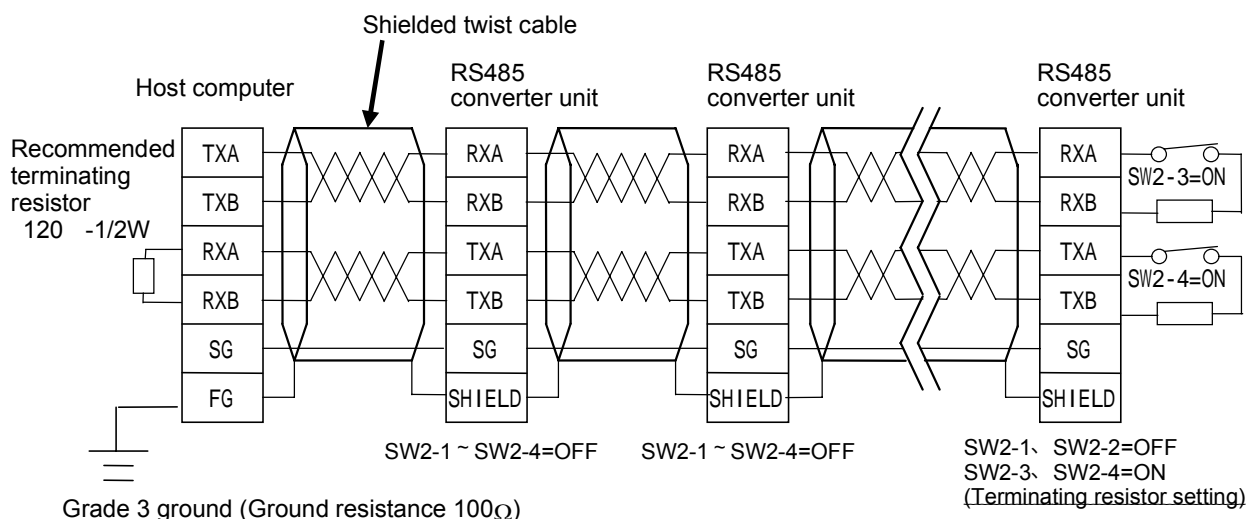

Connection example for 2-wire system

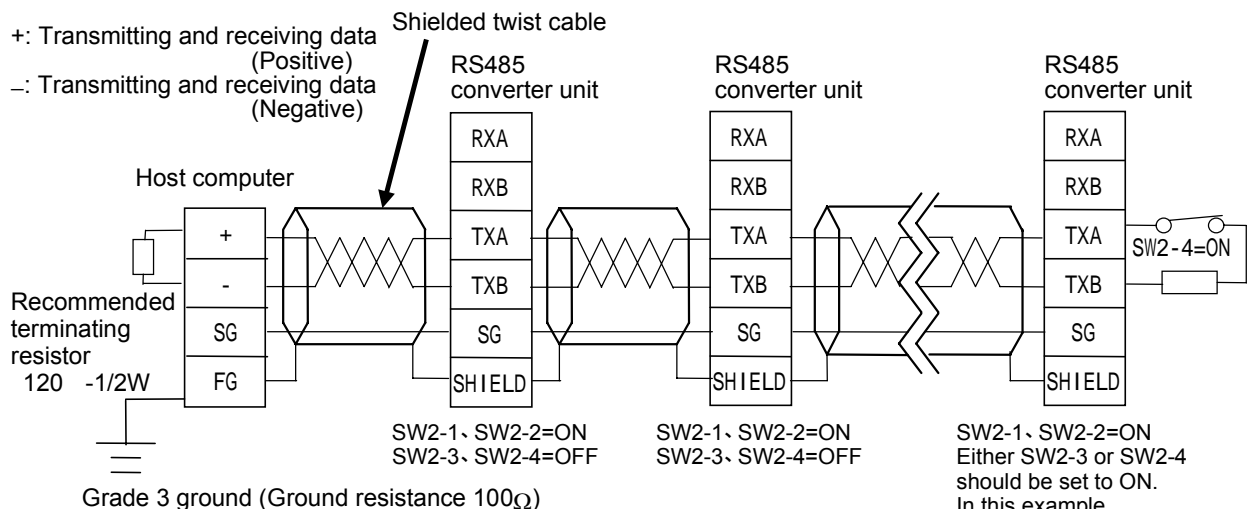

* Terminal numbers of host computer differ with models.
Read the instruction manual of host computer before wiring.

SW2-1、SW2-2=ON
Either SW2-3 or SW2-4
should be set to ON.
In this example,
SW2-3 = OFF, SW2-4 = ON
(Terminating resistor setting)

5. Dimensions

Outline drawing of RS485 Converter Unit (RS4002Z)

(Unit: mm)

Dimension of the unit body

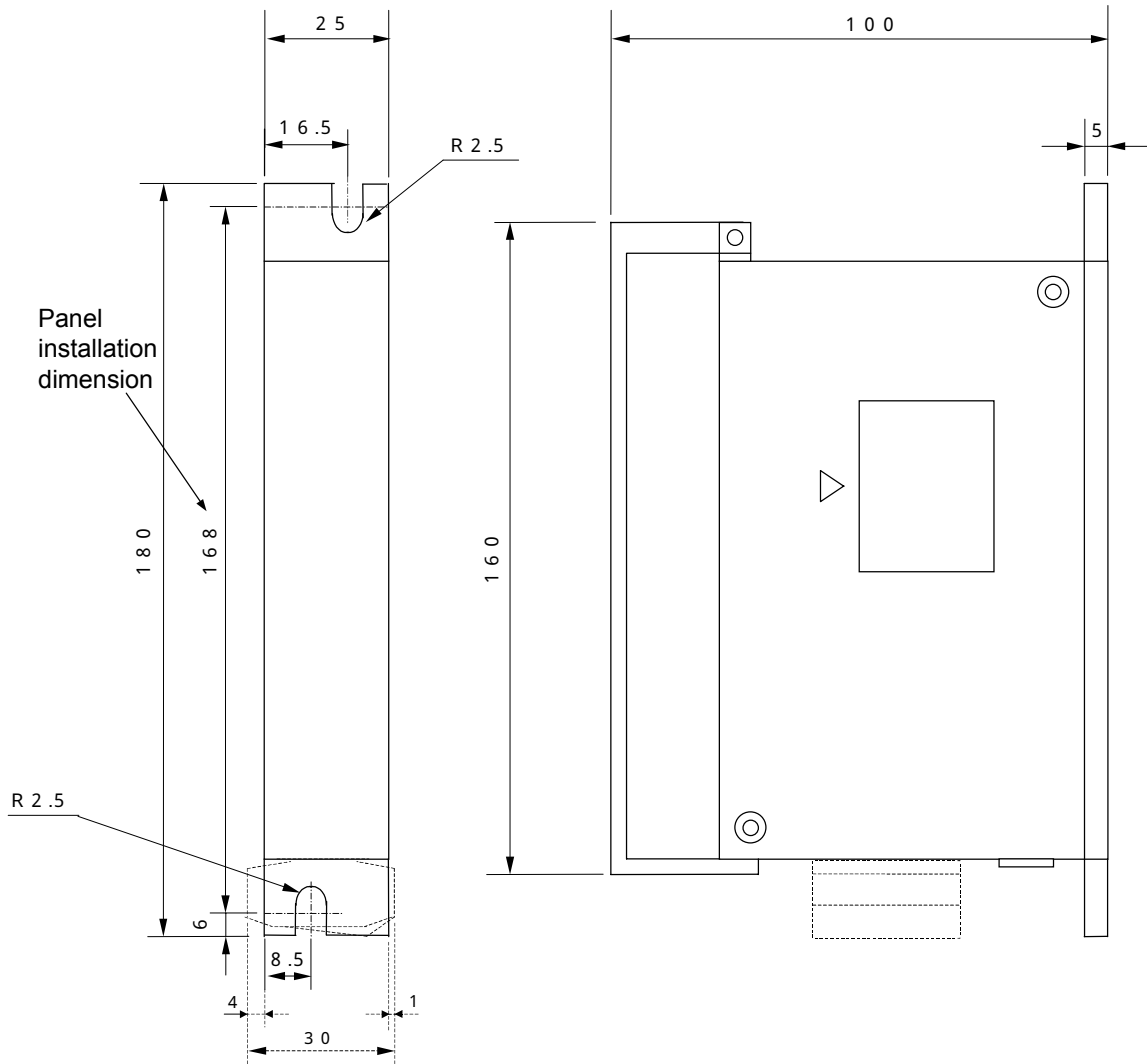

6. Communication parameters

Be careful the parameter setting range, initial value, etc. may change with the inverter models.

| Function | Parameter | Note |
|---------------------|-------------|---|
| Communication speed | <i>F800</i> | Communication speed must be the same in the same network (Inverters, Host computer, RS485 units). |
| Parity | <i>F801</i> | Parity setting must be the same in the same network (Inverters, Host computer). Furthermore, set bit length using the setting switch referring to parity bit specification. (Refer to page 6.) |
| Inverter number | <i>F802</i> | Do not assign the same inverter number in the same network (Inverters, Host computer). Need to set the inverter number in the transmission format. |

7. Specifications

| Item | Specifications |
|---------------------|--|
| Part number | RS4002Z-0 |
| Service environment | Indoors. Altitude of less than 1000m. (3280ft) Must not be exposed to direct sunlight, subjected to corrosive and/or explosive gases, vapor, dust, chips, cutting oil, grinding agent, etc. |
| Ambient temperature | From -10°C to +50°C (14°F to 104°F) |
| Storage temperature | From -25°C to +65°C (-13°F to 149°F) |
| Relative humidity | 20 to 90% (no condensation allowed) |
| Vibration | 5.9 m/s ² (0.6G) or less (10 to 55 Hz) (Conforming to JIS C0040) |

8. Warranty

Any part of the RS485 Option Unit that proves defective will be repaired free of charge under the following conditions:

1. If and when a trouble occurs on the option unit properly installed and handled within one year of delivery, and if the trouble is clearly attributable to defects inherent in our design and manufacture, the product will be repaired free of charge.
2. The warranty covers only the delivered option unit.
3. Even in the term of the warranty, repair service will be charged for the following cases.
 - 1) Fault or damage resulting from misuse, unauthorized modification or repair.
 - 2) Fault or damage resulting from falling down of the product or traffic accident during transportation.
 - 3) Fault or damage originating from fire, salt water/salty breezes, some kind of gas, earthquake, storm or flood, lightning, abnormal supply voltage, other natural disasters.
 - 4) Fault or damage caused by improper use of this option unit as it is used for a purpose out of its original function.
4. If there is another special warranty contracted for this option unit, the special warranty has priority over this warranty.

