

# Extended Panel Operation Manual

## RKP001Z-0

### Table of Contents

|    |   |   |
|----|---|---|
| 1. | NAMES AND FUNCTIONS OF MAIN PARTS ..... | 3 |
| 2. | CONNECTION AND START-UP .....           | 4 |
| 3. | DIMENSIONS .....                        | 5 |
| 4. | PROTECTION FUNCTION .....               | 6 |
| 5. | SPECIFICATIONS .....                    | 6 |
| 6. | WARRANTY .....                          | 6 |

This Extended Panel cannot use at TOSVERT VF-S7/S7e inverter has a CPU whose version is V100 to V103.

For checking the version number of the CPU, refer to the "Monitor" paragraph in the instruction manual of the inverter.

### Toshiba Schneider Inverter Corporation

#### NOTE

1. Make sure that this operation manual is delivered to the end user of the Extended Panel.
2. Read this manual before installing or operating the Extended Panel. And keep it in a safe place for reference.

# Introduction

Thank you for purchasing the “Extended Panel (RKP001Z)” for TOSVERT series inverter. Read the safety precautions in the “*Inverter Instruction Manual*” before powering up your inverter. Using this Extended Panel, display and adjustment of the inverter can be controlled remote from 5 meters apart form it.

This operation manual gives explanations of connecting method of the “Extended Panel” and others. Please read the entire manual carefully before attempting to control your inverter via Extended Panel.

In addition, it has this manual kept to the operator using " Extended Panel ", and please use it for future maintenance and inspection.

**[Explanation of part number of Extended Panel]**

RKP001Z - 0

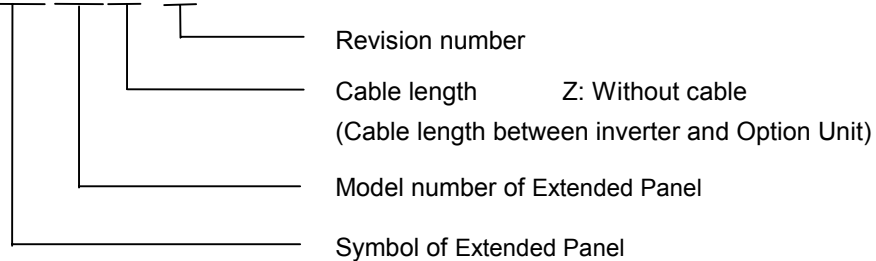

**[Check of accessories]**

The Extended Panel is shipped together with the following accessories in the same package. On opening the packing case, check to see if the following accessories are contained or not.

(1) Operation manual of Extended Panel.....1 copy  
(E6580723)

(2) Spacer (length:20mm).....2 pcs

(3) Screw and nut for fixing  
Extended Panel (M3 x 30mm).....2 pcs

(Note) The Extended Panel (Part Number : RKP001Z) is not provided with connection cable between the inverter and Option Unit. This should be purchased separately.

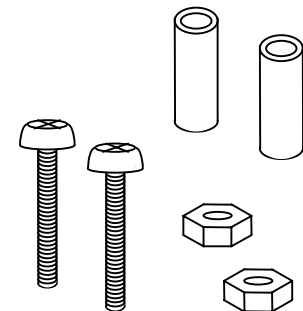
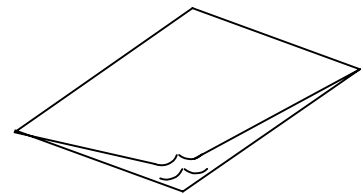

| Part number of connection cable between the Inverter and Option Unit | Cable length    |
|--|-----------------|
| CAB0011  | 1m (1.2m, 4ft)  |
| CAB0013  | 3m (3.6m, 12ft) |
| CAB0015  | 5m (4.8m, 16ft) |

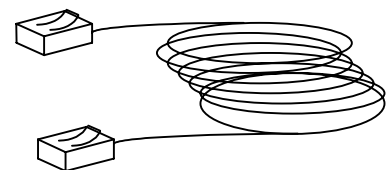





# Carefully read the following notes





## Safety precautions

On the inverter and in its instruction manual, important information is contained for preventing injuries to users and damages to assets and for proper use of the device. Read the instruction manual attached to the inverter along with this operation manual for completely understanding the safety precautions and adhere to the contents of these manuals.

### Handling in general

|  <b>Danger</b>        |   |
|--|---|
| <br>Never Disassemble | <ul style="list-style-type: none"> <li>▼ Never disassemble, modify or repair the product. Disassembling the inverter could cause electric shocks, fire or injuries. For repairs, call your agency.</li> </ul>   |
| <br>Prohibited        | <ul style="list-style-type: none"> <li>▼ Do not remove connectors when the power is on. It could lead to electric shocks.</li> <li>▼ Do not put or insert foreign objects such as waste cable, bars, or wires into the product. It could lead to electric shocks or fire.</li> <li>▼ Do not splash water over the product. It could lead to electric shocks or fire.</li> </ul> |
| <br>Mandatory        | <ul style="list-style-type: none"> <li>▼ Wiring should be conducted after turning the inverter power off.</li> <li>▼ Turn off the power immediately in case any abnormalities such as smokes, smells or abnormal noise are found. Neglect of these conditions could lead to fire. For repairs, call your agency.</li> </ul>   |

### Transportation and installation

|  <b>Danger</b>   |   |
|---|---|
| <br>Prohibited   | <ul style="list-style-type: none"> <li>▼ Do not install or operate the inverter if it is damaged or any part is missing from it. Operating the inverter in a defective condition could lead to electric shocks or fire. For repairs, call your agency.</li> <li>▼ Do not put any inflammable material near the product. It could catch fire if the product sparks because of a breakdown and the like.</li> <li>▼ Do not install the product where it could be splashed with water and the like. It could lead to electric shocks or fire.</li> </ul> |
| <br>Mandatory    | <ul style="list-style-type: none"> <li>▼ The product must be used under environmental conditions prescribed in this operation manual. Using the product under conditions not specified by the operation manual could lead to breakdown.</li> </ul>  |
|  <b>Cautions</b> |   |
| <br>Prohibited   | <ul style="list-style-type: none"> <li>▼ Do not install the product in any place subject to vibrations or it could fall. Otherwise it can cause injury to people.</li> </ul>  |

### About operation

|  <b>Danger</b> |   |
|---|---|
| <br>Prohibited | <ul style="list-style-type: none"> <li>▼ Do not wipe the body with a wet cloth. It could lead to electric shocks.</li> <li>▼ Do not pull on the cable. It could cause damage or error.</li> </ul> |

About disposal of the product

| <b>⚠ Cautions</b>     |  |
|-----------------------|--|
| <b>!</b><br>Mandatory | <ul style="list-style-type: none"> <li>▼ Dispose of the product as an industrial waste.<br/>Unless it is disposed of as an industrial waste, it will become risks for human injury.</li> </ul> |

Cautions on use

| <b>Cautions</b> |   |
|-----------------|---|
|                 | <ul style="list-style-type: none"> <li>▼ Avoid installation locations that may be subjected to rapid changes in ambient temperature or/and humidity.</li> <li>▼ Route the transmission cable separate from the inverter input/output power wiring.<br/>When disconnecting connection cable, make sure to hold its connector with care not to give unreasonable stress to the cable and the unit.</li> <li>▼ Since connectors of optional cables have locking pawls for disconnection prevention at the inverter and the Option Unit, disconnect such a connector while pressing the pawl by finger for unlocking.</li> <li>▼ Mount the Option Unit securely on the panel, otherwise it could fall and cause malfunction or breakdown.</li> <li>▼ Connect an electromagnetic contactor or the like between the inverter and the power source to secure external control of emergency stop of operation.</li> </ul> |

## 1.Names and functions of main parts

Names and functions of main parts of the Extended Panel are shown in the following figure.

Even though the extended panel is connected, the inverter's panel is available.

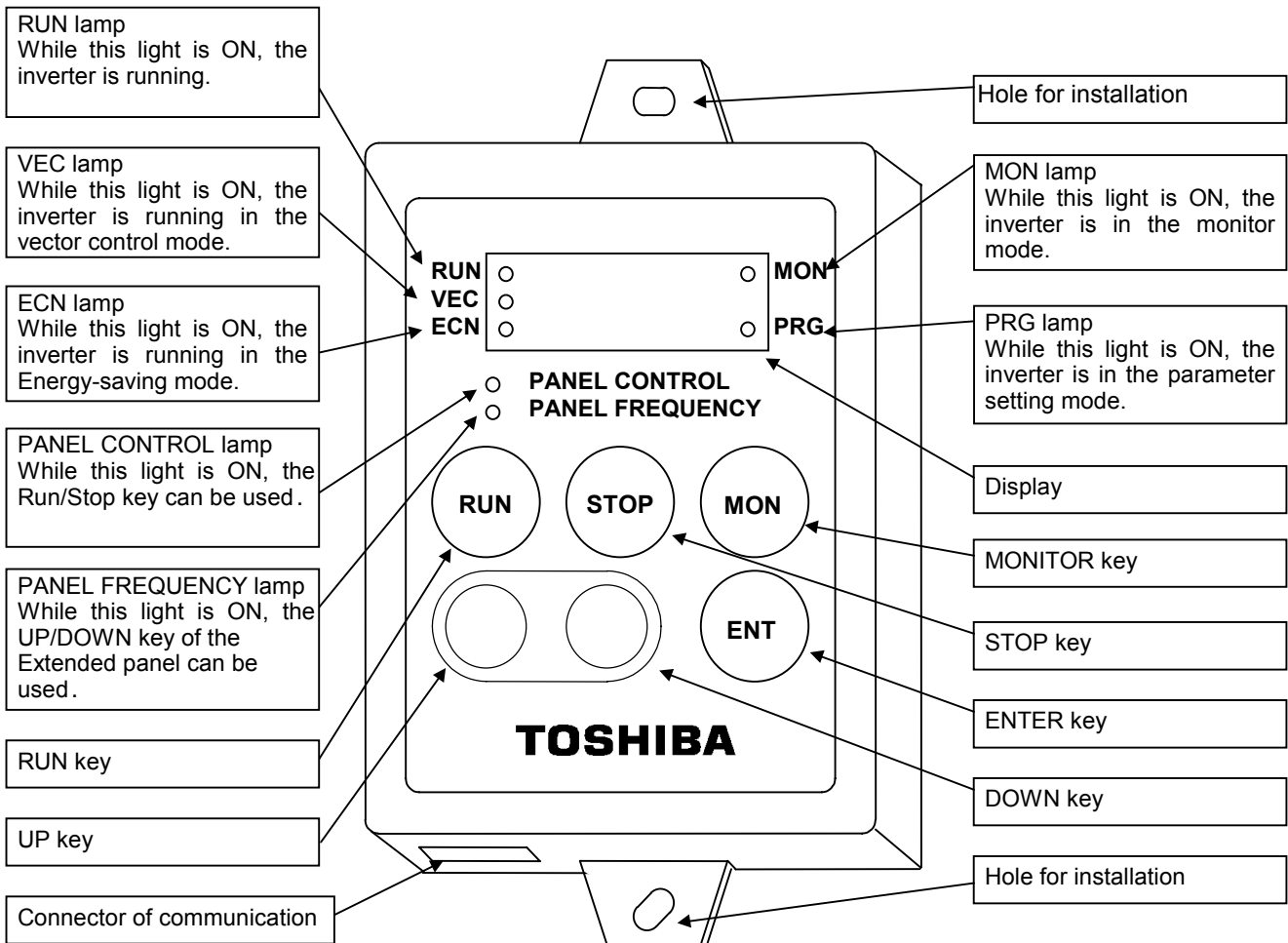

## 2.Connection and start-up

Connect the Extended Panel with the inverter according to the procedure mentioned below.

- 1) Make sure the charge lamp of the inverter is off, more than 10 minutes later after turned the power off.
- 2) Connect the communication connectors of the extended panel to the inverter, which has common serial option (communication) connector, with the optional cable.
- 3) Fix the communication cables after connected.
- 4) Power on the inverter after finished connection, and the display accordingly becomes on.

In case of removing the cable, remove it after confirmed item (1) above.

<< Connection (Example:VF-S7) >>

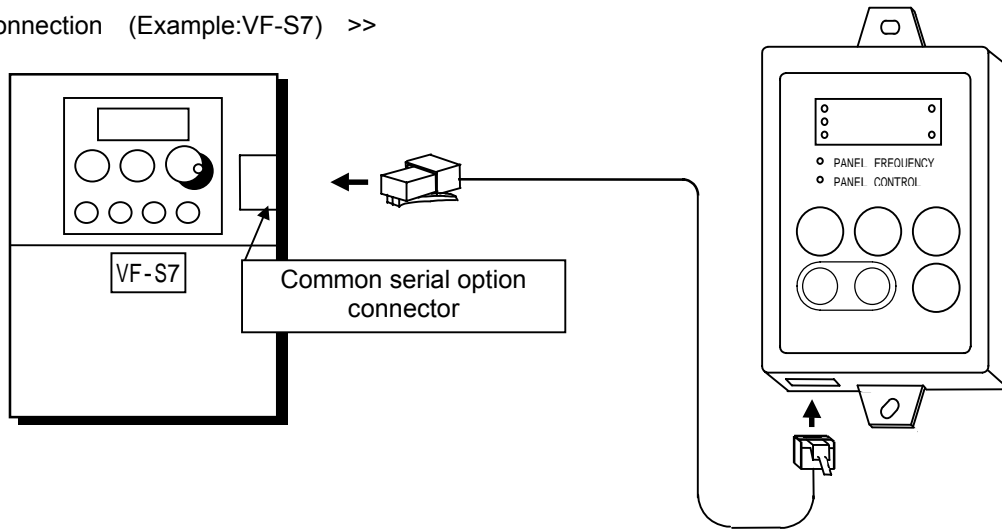

### Mounting

Mount the extended panel(RKP001Z) in front of the panel board as mentioned below.

Make an opening for mounting the extended panel in front of panel board referring to “Figure1. Panel cut dimensions”, and then set the extended panel in the opening with M3 screws, nuts and spacers supplied as accessories referring to “Figure2. Mounting of extended panel”.

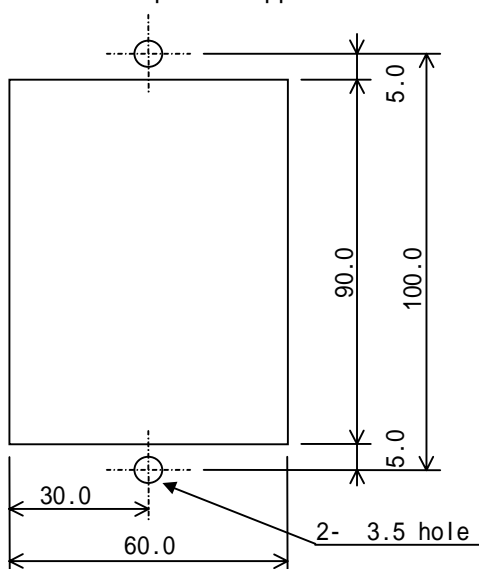

Figure1. Panel cut dimensions (Unit : mm)

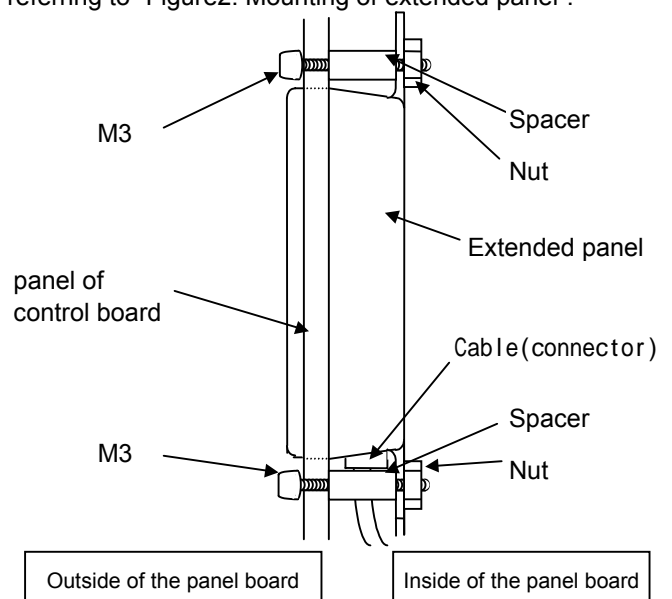
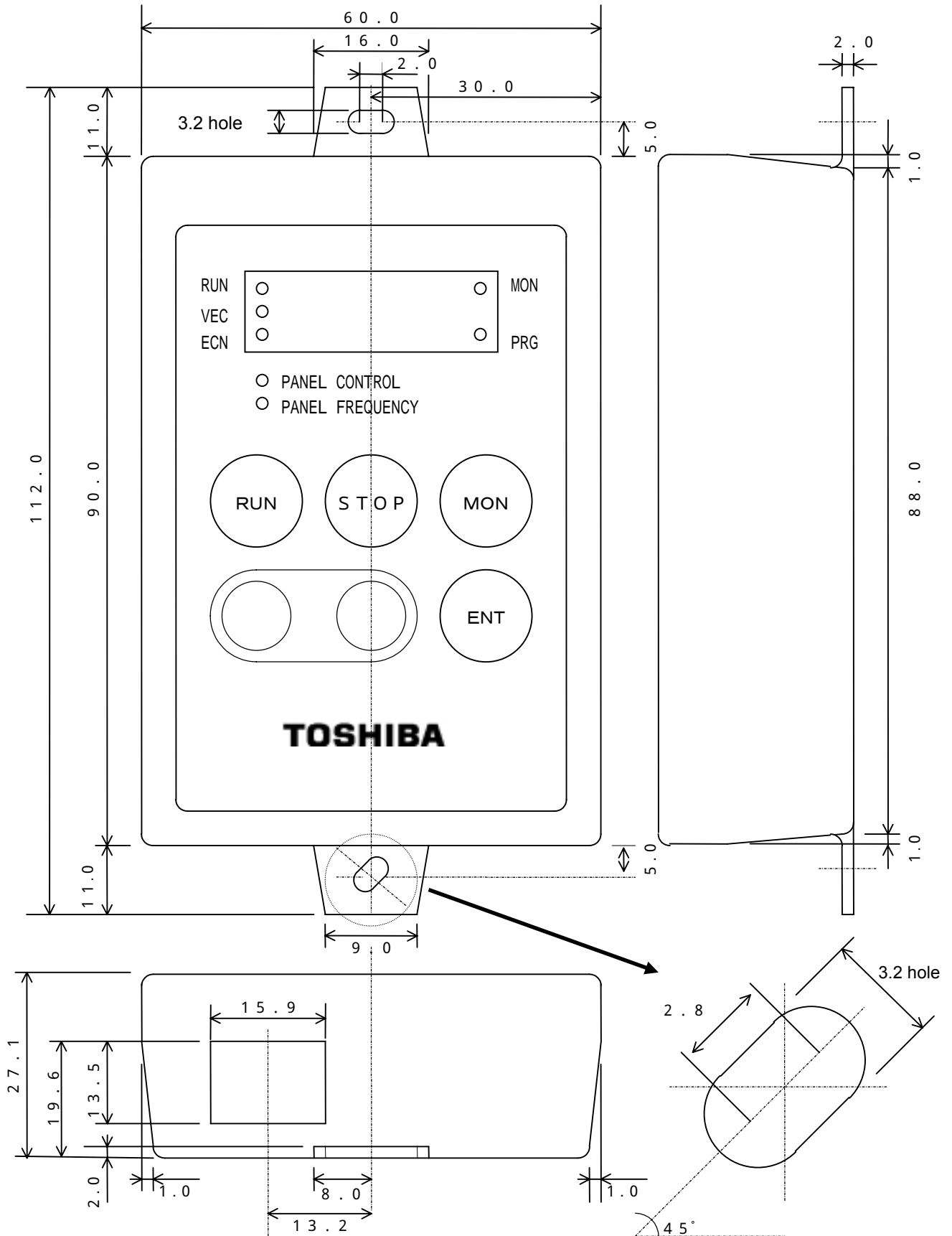

Figure2. Mounting of extended panel

**3.Dimensions**

Dimensions of the extended panel are shown below. (unit : mm)



## 4. Protection function

Error indication of the extended panel are shown in the following table. If such an indication appears on the display, see the error indication of the inverter at the same time.

| Indication    | Details               | Measures to deal with the situation  |
|---------------|-----------------------|--|
| <i>r Rn.E</i> | RAM error             | Reset the extended panel. If the same indication appears again after resetting, ask the dealer to investigate the cause.   |
| <i>r On.E</i> | ROM error             |  |
| <i>CPU.E</i>  | CPU error (watch dog) |  |
| <i>COm.E</i>  | Communication error   | The error status will automatically be cancelled by recovery of normal communication status.<br>Check connection of the communication cable.<br>After checking connection of the communication cable, reset the extended panel. If the same indication appears again after resetting, ask the dealer to investigate the cause. |

## 5. Specifications

| Item                | Specifications  |
|---------------------|---|
| Part number         | RKP001Z-0   |
| Service environment | Indoors. Altitude of less than 1000m (3280 ft).<br>Must not be exposed to direct sunlight, subjected to corrosive and/or explosive gases, vapor, dust, chips, cutting oil, grinding agent, etc. |
| Ambient temperature | From -10°C to +50°C (14°F to 104°F)   |
| Storage temperature | From -25°C to +65°C (-13°F to 149°F)  |
| Relative humidity   | 20 to 90% (no condensation allowed)   |
| Vibration           | 5.9m/s <sup>2</sup> or less   |
| Cooling system      | Self-cooling  |

## 6. Warranty

Any part of the Extended panel that proves defective will be repaired and adjusted free of charge under the following conditions:

1. If and when a trouble occurs on the Extended panel properly installed and handled within one year of delivery, and if the trouble is clearly attributable to defects inherent in our design and manufacture, the product will be repaired free of charge.
2. The warranty covers only the delivered Extended panel.
3. Even in the term of the warranty, repair/adjustment service will be charged for the following cases.
  - 1) Fault or damage resulting from misuse, unauthorized modification or repair.
  - 2) Fault or damage resulting from falling down of the product or traffic accident during transportation.
  - 3) Fault or damage originating from fire, salt water/salty breezes, some kind of gas, earthquake, storm or flood, lightning, abnormal supply voltage, other natural disasters.
  - 4) Fault or damage caused by improper use of this option unit as it is used for a purpose out of its original function.
4. If there is another special warranty contracted for this Extended panel, the special warranty has priority over this warranty.