

Parameter Writer Operation Manual

PWU001Z-1

Table of Contents

1. OVERVIEW.....	4
2. NAMES AND FUNCTIONS OF MAIN PARTS	5
3. CONNECTION AND START-UP.....	6
4. FUNCTIONS IN DETAIL	7
4.1. Copying function “COPY”.....	7
4.2. Simply copying function	8
4.3. Comparing function “COMP”.....	9
4.4. Memory protection function “PROT”	11
4.5. Memory initializing function “CLR”	12
4.6. Function to serve as remote keypad	12
5. INDICATIONS ON DISPLAY.....	13
6. RESETTING FUNCTION	14
7. SPECIFICATIONS	14
8. WARRANTY.....	14

This Parameter Writer cannot use at TOSVERT VF-S7/S7e inverter has a CPU whose version is V100 to V103.

For checking the version number of the CPU, refer to the “Monitor” paragraph in the instruction manual of the inverter.

NOTES

1. Make sure that this instruction manual is delivered to the end user of the Parameter Writer.
2. Read this manual before installing or operating the Parameter Writer. And keep it in a safe place for reference.

Toshiba Schneider Inverter Corporation

© Toshiba Corporation 1996

All Rights Reserved.

Preface

Thank you for purchasing the "Parameter Writer (PWU001Z)" for TOSVERT series inverter. Using this product, you can copy data from one place to another and then execute data comparison between the inverter and the parameter writer's memory or between the memories of the parameter writer itself.

Before using the Parameter Writer, carefully read this operation manual to make your Parameter Writer demonstrate its excellent performance entirely and correctly.

After reading this operation manual, carefully keep it at the side of the operator of the Parameter Writer for future inspection and maintenance.

[Explanation of model number of Parameter Writer]

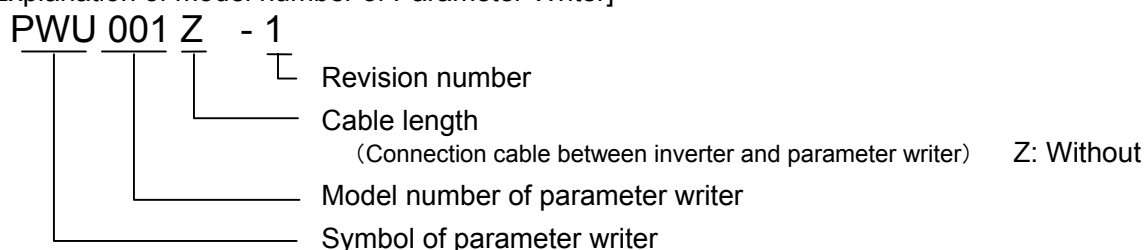

[Check of accessories]

The Parameter Writer is shipped together with the following accessories in the same package. On opening the packing case, check to see if the following accessories are contained or not.

(1) Operation manual of Parameter Writer... 1 copy.



(2) Spacer (length: 20 mm)... 2 pcs

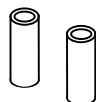

(3) Screw and nut for fixing

Parameter Writer (M3 x 30 mm)... 2 pcs each

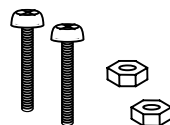

(Note)

The Parameter Writer (Part Number : PWU001Z) is not provided with connection cable between the inverter and Option Unit. This should be purchased separately.

Part number of connection cable between the Inverter and Option Unit	Cable length
CAB0011	1m (1.2m, 4ft)
CAB0013	3m (3.6m, 12ft)
CAB0015	5m (4.8m, 16ft)

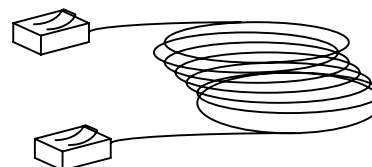





Carefully read the following notes





Safety precautions

On the inverter and in its instruction manual, important information is contained for preventing injuries to users and damages to assets and for proper use of the device. Read the instruction manual attached to the inverter along with this instruction manual for completely understanding the safety precautions and adhere to the contents of these manuals.



■ Handling in general

 Danger	
 Never Disassemble	<ul style="list-style-type: none"> ▼ Never disassemble, modify or repair the product. Disassembling the inverter could cause electric shocks, fire or injuries. For repairs, call your agency.
 Prohibited	<ul style="list-style-type: none"> ▼ Do not remove connectors when the power is on. It could lead to electric shocks. ▼ Do not put or insert foreign objects such as waste cable, bars, or wires into the product. It could lead to electric shocks or fire. ▼ Do not splash water over the product. It could lead to electric shocks or fire.
 Mandatory	<ul style="list-style-type: none"> ▼ Wiring should be conducted after turning the inverter power off. ▼ Turn off the power immediately in case any abnormalities such as smokes, smells or abnormal noise are found. Neglect of these conditions could lead to fire. For repairs, call your agency.



■ Transportation and installation

 Danger	
 Prohibited	<ul style="list-style-type: none"> ▼ Do not install or operate the inverter if it is damaged or any part is missing from it. Operating the inverter in a defective condition could lead to electric shocks or fire. For repairs, call your agency. ▼ Do not put any inflammable material near the product. It could catch fire if the product sparks because of a breakdown and the like. ▼ Do not install the product where it could be splashed with water and the like. It could lead to electric shocks or fire.
 Mandatory	<ul style="list-style-type: none"> ▼ The product must be used under environmental conditions prescribed in this instruction manual. Using the product under conditions not specified by the instruction manual could lead to breakdown.
 Cautions	
 Prohibited	<ul style="list-style-type: none"> ▼ Do not install the product in any place subject to vibrations or it could fall. Otherwise it can cause injury to people.

■ Caution on operation

 Danger	
 Prohibited	<ul style="list-style-type: none"> ▼ Do not operate keys with a wet hand or wipe with a wet duster. Not following this instruction could cause electrocution. ▼ Do not shock the Parameter Writer (do not fall down). Not following this instruction could cause malfunction or breakdown. ▼ Do not pull the transmission cable. Not following this instruction could cause malfunction or breakdown.

■ Caution on disposing of Parameter Writer

 Warning	
 Mandatory	<ul style="list-style-type: none"> ▼ Dispose of the Parameter Writer as industrial waste. Not following this instruction could cause injury.

Notes on operation

NOTES		
	<ul style="list-style-type: none"> ▼ Install the unit avoiding a place where ambient temperature or/and humidity change sharply. ▼ Arrange the transmission cable apart from the power cable of the inverter to prevent the inverter from malfunctioning to be caused by electromagnetic noise. ▼ Install the unit on the panel of a cabinet if it is used as a remote keypad. The unit not installed on the panel of a cabinet could cause the unit falling, resulting in damage and malfunction of the unit. ▼ Install a magnetic contactor etc. to the power supply of the inverter, so that an emergency stop can be executed securely from outside. ▼ The integrity of data storage is guaranteed for up to 10 years. ▼ The operating life of EEPROM (data storage device) is 10000 operations. Do not execute writing operations more than 10000 times. ▼ Do not turn off power or remove the connection cable between the inverter and the parameter writer while a copying operation of parameter writer is executed. If the inverter power is turned off or the connection cable is removed while parameters are being copied, data cannot be written correctly. ▼ Do not copy data from the parameter writer to inverter while the inverter is running. Some of the parameters cannot be written when the inverter is in operation. ▼ Make sure to execute “<i>COMP</i>” (compare) function to check copied data when “<i>COPY</i>” (copy) function is executed. Depending on circumstances, data writing of copying operation may not have been successful. ▼ When a copying operation is executed between two inverters with different capacities, some of the parameters that vary with the capacity of inverters will also be copied. Therefore, when you have executed a copying operation between the inverters with different capacities, we suggest you initialize the copied parameters of the inverter in accordance with the level of inverter’s capacity. See the inverter instruction manual on how to initialize parameters. 	<p>P7, 8</p> <p>P7, 8</p> <p>P7-9</p> <p>P13</p>

1. Overview

Following six functions are available with this parameter writer.

1. Copying function

Data can be copied from a memory to another memory among four memories, three (memories A, B, C) of the parameter writer and one of the inverter.

- (1) Data copy from parameter writer to inverter
- (2) Data copy from inverter to parameter writer
- (3) Data copy from a memory to another memory of the parameter writer

2. Simply copying function

Data stored in a memory of the parameter writer can be copied to the inverter's memory by simple operation of two keys.

3. Comparing function

Data written on two memories among four memories, three of the parameter writer and one of the inverter, can be compared with each other.

- (1) Comparing data of the parameter writer with data of the inverter.
- (2) Comparing data of the inverter with data of the parameter.
- (3) Comparing data of two memories of the parameter writer with each other.

4. Memory protecting function

Data written on the inverter's memory and the memories A, B and C of the parameter writer are protected by this function (to inhibit data writing).

5. Memory initializing function

A selected memory (memory A, B, C) or all of memories including system memory of the parameter writer, if selected, are initialized by this function.

6. Function to serve as remote keypad

The parameter writer can be used as an operation panel of the inverter.

■ Memory configuration

The parameter writer has three memories of A, B and C to retain three kinds of parameters for the inverter.

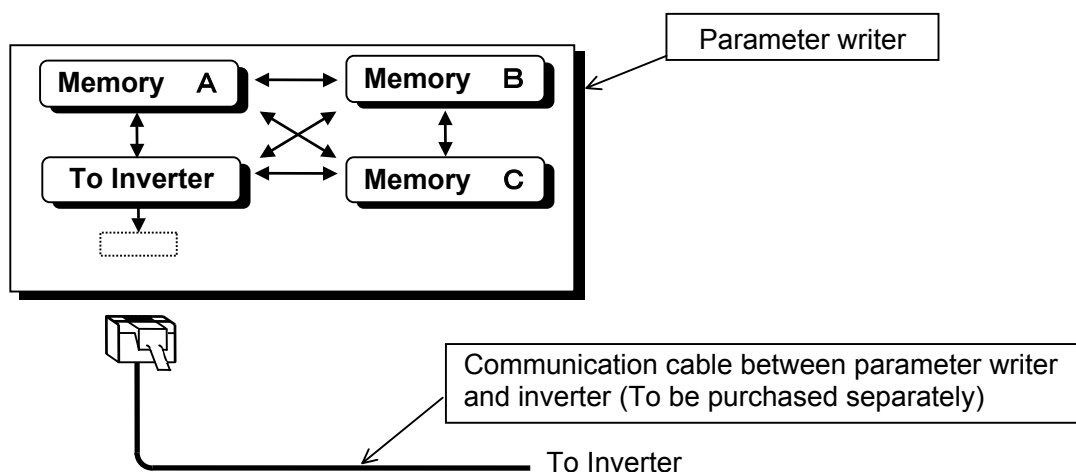



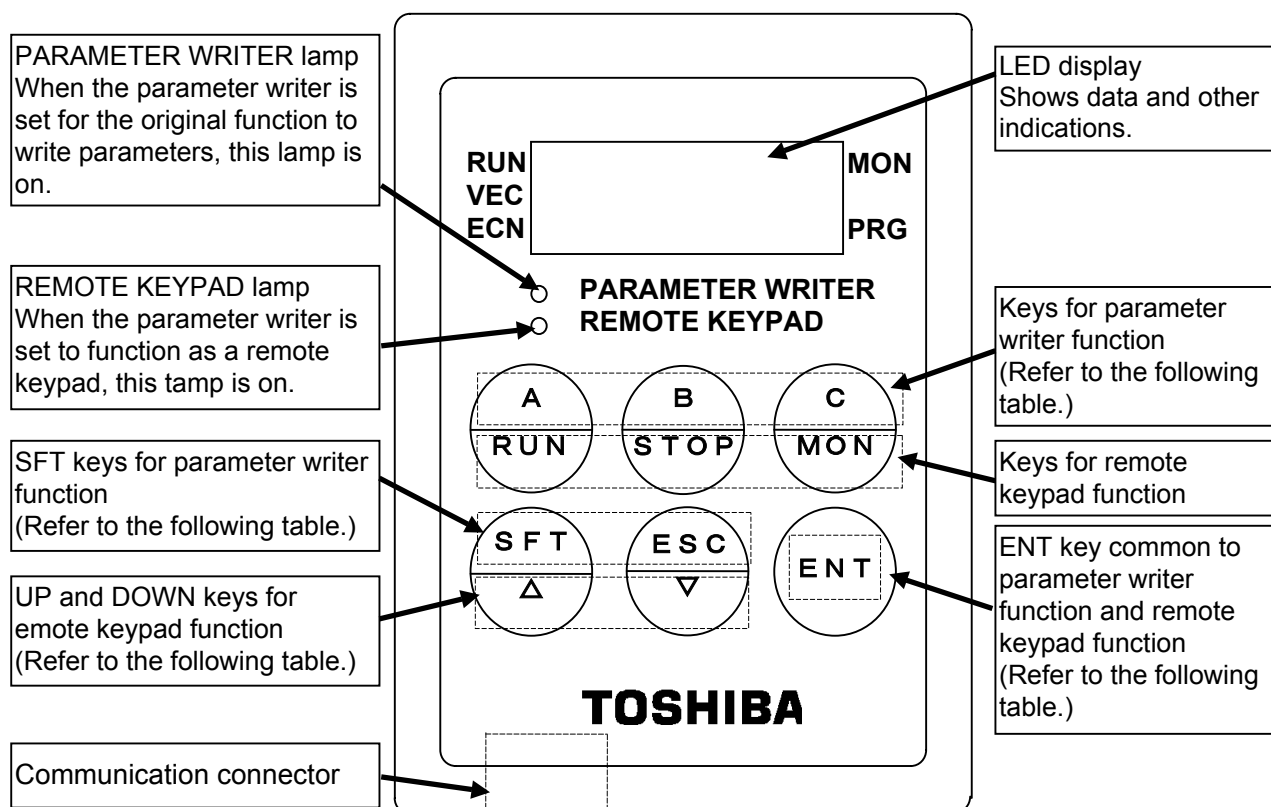

2. Names and functions of main parts

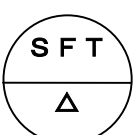

■ Operation keys and their functions

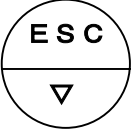
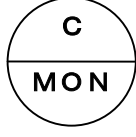
(Functions of operation keys explained in the following table are in the condition that the parameter writer is used for the original purpose to copy, write, compare and protect data. When the parameter writer is used as a remote keypad, respective operation keys function as same as operation keys on the inverter. For details of those functions, refer to the operation manual of the inverter.)

Operation key	Function	Operation key	Function
	Memory A key (Exclusive key for simply copying) In the simply copying function, this key is used to specify the memory A of the parameter writer as the origin to transmit data. (In remote keypad function: RUN key)		SFT key To be used for selecting a function (copying, comparing, protecting data) or for selecting a memory (from among inverter's memory, memory A, B and C of parameter writer). (In remote keypad function: UP key)
	Memory B key (Exclusive key for simply copying) In the simply copying function, this key is used to specify the memory B of the parameter writer as the origin to transmit data. (In remote keypad function: STOP key)		ESC key To be used to return to the status one before. (In remote keypad function: DOWN key)
	Memory C key (Exclusive key for simply copying) In the simply copying function, this key is used to specify the memory C of the parameter writer as the origin to transmit data. (In remote keypad function: MON key)		ENT key To be used to decide a function or memory or to execute the decided function. (In remote keypad function: ENT key)

3. Connection and start-up

Connect the Parameter Writer with the inverter according to the procedure mentioned below.

- (1) Turn off the inverter and wait for 10 minutes or more. Then, make sure that the CHARGE lamp of the inverter is off.
- (2) Connect the communication connectors of the parameter writer to the inverter, which has common serial option(communication) connector, with the optional cable. (See the instruction manual of inverter)
- (3) Turn on the inverter, and the parameter writer is automatically started up with the display being on.
- (4) When this unit is used for the parameter writer, confirm that the PARAMETER WRITER lamp is on. Or when this unit is used for the remote panel, confirm the REMOTE PANEL lamp is on.
- (5) If a change from the PARAMETER WRITER function to the REMOTE PANEL function mutually takes place, turn off the power of the inverter and confirm that the LED display on the operation panel is turned off. Then, turn on the power of the parameter writer while pressing the ENT key of the parameter writer.

When disconnecting the parameter writer from the inverter, do it according to the step 1) of the above-mentioned procedure.

■ Connection example of parameter writer and inverter

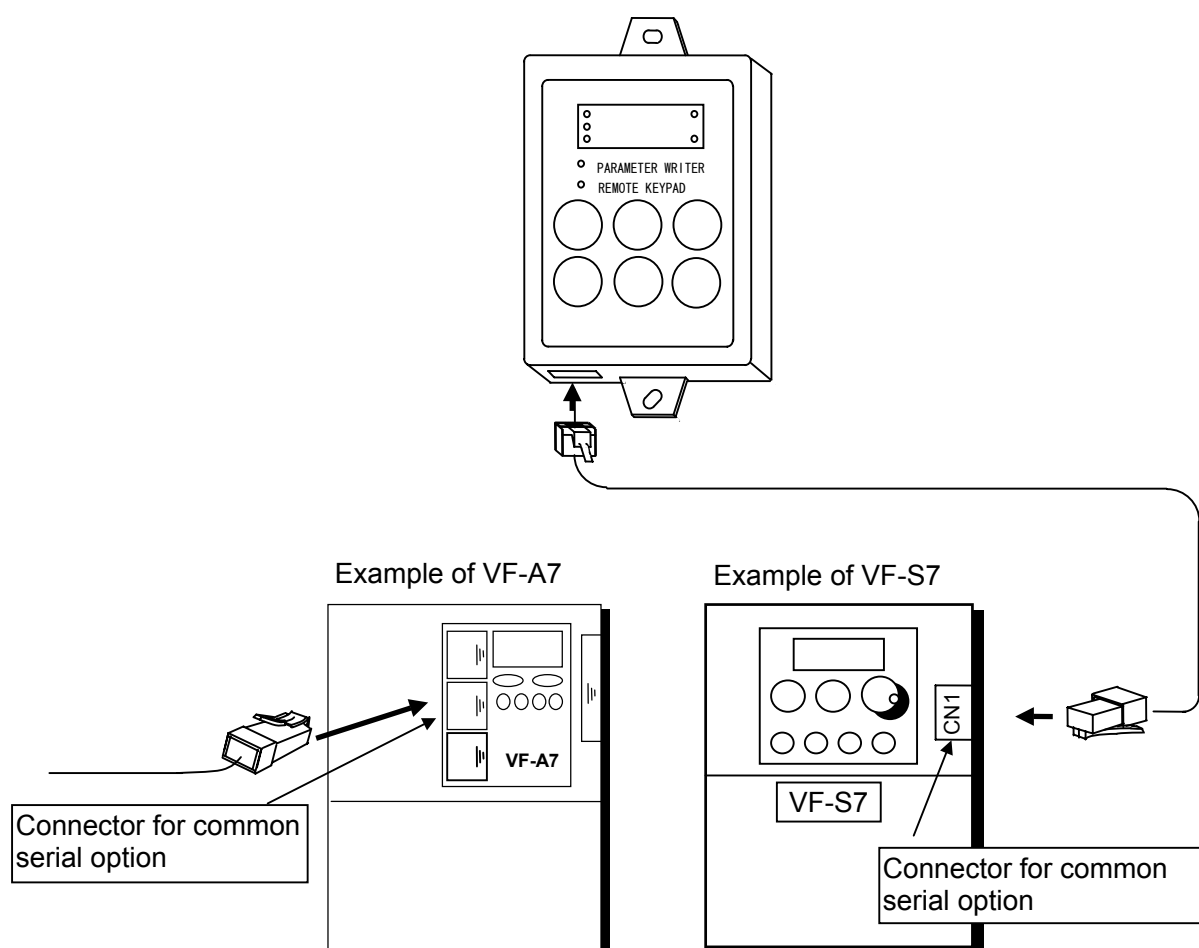







4. Functions in detail

4.1. Copying function “COPY”

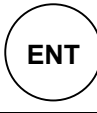
Data stored in a memory can be copied to another memory which memories are selected from among four memories that are the inverter's memory, memories A, B and C of the parameter writer.

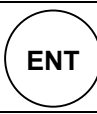
Note: To copy data to the inverter's memory, do it when the inverter is stopped. If you copy data to the inverter while the inverter is running, some of the parameters fail to be copied. Furthermore, make sure to check the copied data by executing data comparison (COMP) between the source and the destination memories after the copying operation.

Operating procedure

Key	LED indication	Key operation and description
—	“CHC” → “InIt” → “COPY”	When the parameter writer is turned on as it is connected with the inverter, “CHC” appears on the display first and then “InIt” appears to indicate that the power supply is being initialized. Lastly, the display shows “COPY”.
	“COPY” → “COMP” → “PrOt” → “CLr” → “COPY”	— Selecting a desired function — Select “COPY” (copying function) with the SFT key. Each time the SFT key is pressed, indication on the display changes from “COPY” to “COMP” (comparing function), “PrOt” (memory protecting function), “CLr” (memory initializing function) and to “COPY” again in this order.
	“COPY” → “In”	— Entering the selected function — After selecting “COPY” with the SFT key, press the ENT key and “In” (selecting inverter memory) appears on the display.
	“In” → “A” → “b” → “C” → “In”	— Selecting a memory to copy its data — Select a memory to copy its data with the SFT key. Each time the SFT key is pressed, indication on the display changes from “In” (Selecting inverter memory) to “A” (selecting memory A), “b” (Selecting memory B), “C” (selecting memory C) and to “In” again in this order.
	“In” → “In-A”	— Entering the memory to copy its data — After selecting “In” (selecting inverter memory, by way of example) with the SFT key, press the ENT key and “In-A” appears on the display.
	“In-A” → “In-b” → “In-C” → “In-A” (“A-In” → “A-b” → “A-C” → “A-In”)	— Selecting a memory to transcribe copied data — Select a memory to transcribe copied data with the SFT key. Each time the SFT key is pressed, indication on the display changes from “In-A” (copying data from inverter memory to memory A) to “In-b” (copying data from inverter memory to memory B), “In-C” (copying data from inverter memory to memory C), and to “In-A” again in this order. If the memory A is selected as the origin to copy data, indications differently appear as shown in parentheses.
	“In-A” → “F000” → “F___”	— Entering the selected memory to transcribe copied data — After selecting “In-A” (selecting memory A, by way of example) with the SFT key, press the ENT key and the display shows “F___” that is the communication number of the parameter being copied.
—	“End” → “__” (two digits)	— Copying is complete — With completion of data copy, “End” appears on the display first and then “__” of a check data (check sum of the origin of copied data) appears. Value of the check data changes depending on the condition of the original data.
	“__” → “COPY”	— Ending copying — Press the ENT key and indication on the display returns to “COPY”. Make sure to check the data with data comparison function (COMP) after this operation.

- If the ESC key is pressed, the parameter writer returns to the status one before.
- When the memory protection function is actuated, the parameter writer inhibits to copy data with “PrOt” appearing on the display.
- If there is no data in the memory A of the parameter writer though it is selected as the origin to copy data, the display shows “Err.A” and copying data is of course impossible. (When the memory B is selected in the same condition, “Err.b” appears on the display. When the memory C is selected in the same condition, “Err.C” appears on the display.)



4.2. Simply copying function

Data stored in the memory A, B or C of the parameter writer can be copied to the inverter's memory with simple operation of two keys to select one of the memories A, B and C. Use this function to set the same parameters to more than two inverters. What differs from the "Copying function" in Section 4.1 is the key operation and the contents of parameters to be copied are the same for both functions.

It is impossible to copy data from the inverter's memory to a memory of the parameter writer in this mode.

Note: To copy data to the inverter's memory, do it when the inverter is stopped. If you copy data to the inverter while the inverter is running, some of the parameters fail to be copied. Furthermore, make sure to check the copied data by executing data comparison (COPY) between the source and the destination memories after the copying operation.

Operating procedure

Key	LED indication	Key operation and description
_____	"CHC" → "In It" → "COPY"	When the parameter writer is turned on as it is connected with the inverter, "CHC" appears on the display first and then "In It" appears to indicate that the power supply is being initialized. Lastly, the display shows "COPY".
	"COPY" → "A - In"	<p>– Selecting and entering a memory to copy its data –</p> <p>Press the key corresponding to the memory to select as the origin to copy data while "COPY" is being displayed.</p> <p>"A" key: To copy data from the memory A to the inverter's memory. "B" key: To copy data from the memory B to the inverter's memory. "C" key: To copy data from the memory C to the inverter's memory.</p> <p>(When the memory A is selected to copy its data to the inverter's memory for example, indication on the display changes from "COPY" to "A - In" (copying data from memory A to inverter's memory)).</p>
	"A - In" → "F000" → "F ___"	<p>– Executing copying –</p> <p>In the status that "In - A" is appearing on the display, press the ENT key and the indication on the display changes to "F ___" of the communication number of the parameter being copied.</p>
_____	"End" → "___" (two digits)	<p>– Copying is complete –</p> <p>With completion of data copy, "End" appears on the display first and then "___" of a check data (check sum of the origin of copied data) appears. Value of the check data changes depending on the condition of the original data.</p>
	"___" → "COPY"	<p>– Ending copying –</p> <p>Press the ENT key and indication on the display returns to "COPY". Make sure to check with data comparison function (COPY) after this operation.</p>

- If the ESC key is pressed, the parameter writer returns to the status one before.
- When the memory protection function is actuated, the parameter writer inhibits to copy data with "Pr Ot" appearing on the display.
- If there is no data in the memory A of the parameter writer though it is selected as the origin to copy data, the display shows "Err.A" and copying data is of course impossible. (When the memory B is selected in the same condition, "Err.b" appears on the display. When the memory C is selected in the same condition, "Err.C" appears on the display.)

The same operation as below can be used to copy data from memory B or memory C of the parameter writer to the inverter.

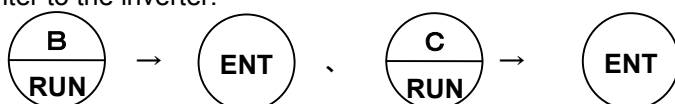

Since the "A", "B" and "C" keys are provided to be used exclusively for the simply copying function, those keys cannot be used for other functions.







4.3. Comparing function “COPY”

This function enables the operator to compare data stored in two memories that are selected from among four memories of the parameter writer's memories A, B and C and the inverter's memory as well as to search a parameter which is different in the setting value from others.

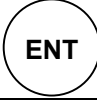
The comparing function cannot be used for editing data because it is provided for searching parameters which are different in setting values from others.

Use the “Remote keypad” function described in Section 4.6 to edit data.

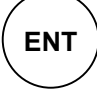
Operating procedure

Key	LED indication	Key operation and description
—	“CHC” → “In It” → “COPY”	When the parameter writer is turned on as it is connected with the inverter, “CHC” appears on the display first and then “In It” appears to indicate that the power supply is being initialized. Lastly, the display shows “COPY”.
	“COPY” → “COPY”	—Selecting a desired function— Select to “COPY” (comparing function) with the SFT key. Each time the SFT key is pressed, indication on the display changes from “COPY” to “COPY” (comparing function), “Pr Ot” (memory protecting function), “Clr” (memory initializing function) and to “COPY” again in this order.
	“COPY” → “In”	—Entering the selected function— After selecting “COPY” with the SFT key, press the ENT key and “In” (selecting inverter memory) appears on the display.
	“In” → “A” → “B” → “C” → “In”	—Selecting a memory to compare its data with another— Each time the SFT key is pressed, indication on the display changes from “In” (selecting inverter memory) to “A” (selecting memory A), “B” (selecting memory B), “C” (selecting memory C) and to “In” again in this order. Select the copy destination area.
	“In” → “InIt.A”	—Entering the memory to compare its data with another— After selecting “In” (selecting inverter memory, for example) with the SFT key, press the ENT key and “InIt.A” appears on the display.
	“InIt.A InIt.B InIt.C InIt.A (At.In At.B At.C At.In)	—Selecting a memory to compare its data with that of the previously selected memory— Each time the SFT key is pressed, indication on the display changes from “InIt.A” (comparing data between inverter memory and memory A) to “InIt.B” (comparing data between inverter memory and memory B), “InIt.C” (comparing data between inverter memory to memory C), and to “InIt.A” again in this order. If the memory A is selected as the memory storing the original data, indications differently appear as shown in parentheses.
	“InIt.A”	—Entering the selected memory to compare its data with the original— After selecting “InIt.A” (selecting memory A to compare its data with that of the inverter's memory for example) with the SFT key, press the ENT key and the parameter writer starts comparing data of the two memories with each other.
	“FOO0” → “FOO2” (If no parameter different from the other is searched, the display shows “End”)	—Executing comparing data (searching different parameters)— After confirming that “FOO0” is appearing on the display, execute comparison of data in order of communication number (refer to the Table of communication numbers.). When the parameter writer searches a parameter different from the other, it discontinues comparing operation and shows the parameter's communication number in blinking numerals. Press the ENT again to continue the comparing operation.
—	“End” → “_”	—Comparing is complete— With completion of data comparison, “End” appears on the display first and then “_” of a check data (check sum of the original data) appears. Value of the check data changes depending on the condition of the original data.
	“_” → “COPY”	—Ending comparing— Press the ENT key and indication on the display returns to “COPY”.

- If the ESC key is pressed, the parameter writer returns to the status one before.

■ Table of communication numbers

The communication numbers for basic parameters are as follows. As to extended parameters, the titles and communication numbers of parameters are the same. See the inverter instruction manual.

Table of communication numbers

Communication number	Title	Function
<i>F000</i>	<i>AV1</i>	Automatic acceleration/deceleration time
<i>F001</i>	<i>AV2</i>	Automatic torque boost
<i>F002</i>	<i>AV3</i>	Automatic environment
<i>F003</i>	<i>CNOd</i>	Operation command mode selection
<i>F004</i>	<i>FN0d</i>	Speed setting mode selection
<i>F005</i>	<i>FN5L</i>	FM terminal meter selection
<i>F006</i>	<i>FN</i>	FM terminal meter adjustment
<i>F007</i>	<i>tYP</i>	Standard setting mode selection
<i>F008</i>	<i>Fr</i>	Forward/reverse selection (At panel control only)
<i>F009</i>	<i>ACC</i>	Acceleration time #1
<i>F010</i>	<i>dEC</i>	Deceleration time #1
<i>F011</i>	<i>FH</i>	Maximum frequency
<i>F012</i>	<i>UL</i>	Upper limit frequency
<i>F013</i>	<i>LL</i>	Lower limit frequency
<i>F014</i>	<i>uL</i>	Base frequency #1
<i>F015</i>	<i>Pt</i>	Motor control mode selection
<i>F016</i>	<i>ub</i>	Manual torque boost #1
<i>F017</i>	<i>OLn</i>	Selection of electronic thermal protection characteristics
<i>F018</i>	<i>sr1</i>	Preset - speed #1
<i>F019</i>	<i>sr2</i>	Preset - speed #2
<i>F020</i>	<i>sr3</i>	Preset - speed #3
<i>F021</i>	<i>sr4</i>	Preset - speed #4
<i>F022</i>	<i>sr5</i>	Preset - speed #5
<i>F023</i>	<i>sr6</i>	Preset - speed #6
<i>F024</i>	<i>sr7</i>	Preset - speed #7

4.4. Memory protection function “PrOt”







The memory protection function protects the selected memory so as to prevent it from erroneous replacement of its data with different data copied from another memory.

When this function is actuated for a selected memory, it inhibits transcribing copied data to the memory but permits to read data from the memory.

At the time of shipment or when all the memories are initialized by memory initialization function (CLr), LED indications are as follows:

“In”、 “R”、 “b”、 “C=“OFF”、 “SUP” = “On”

Operating procedure

Key	LED indication	Key operation and description
—	“CHC” → “InIt” → “COPY”	When the parameter writer is turned on as it is connected with the inverter. “CHC” appears on the display first and then “InIt” appears to indicate that the power supply is being initialized. Lastly, the display shows “COPY”.
	“COPY” → “COMP” → “PrOt”	— Selecting a desired function — Select “PrOt” (memory protecting function) with the SFT key. Each time the SFT key is pressed, indication on the display changes from “COPY” (copying function) to “COMP” (comparing function), “PrOt” (memory protecting function), “CLr” (memory initializing function) and to “COPY” again in this order.
	“PrOt” → “In”	— Entering the selected function — After selecting “PrOt” with the SFT key, press the ENT key and “In” (selecting inverter memory) appears on the display.
	“In” → “R” → “b” → “C” → “SUP” → “In”	— Selecting a memory to protect its data — Each time the SFT key is pressed, indication on the display changes from “In” (selecting inverter memory) to “R” (selecting memory A), “b” (selecting memory B), “C” (selecting memory C), “SUP” (special parameter selection* ¹) and to “In” again in this order. Select the memory to protect its data.
	“In” → “OFF” (When the memory is protected, the display changes to “On” from “In”)	— Entering the memory to protect its data — After selecting “In” (selecting inverter memory, by way of example) with the SFT key, press the ENT key and the display shows the present memory protection status. (When “On” appears on the display, the selected memory is protected. When “OFF” appears on the display, the Selected memory is not protected.)
	“OFF” → “On” → “OFF”	— Protecting the selected memory — Each time the SFT key is pressed, indication on the display changes between “On” (protecting the selected memory) and “OFF” (cancelling protection of the selected memory) alternately.
	“On” → “PrOt”	— Executing protection of the selected memory — After selecting “On” (protecting the selected memory, by way of example) with the SFT key, press the ENT key. The parameter writer starts protecting the selected memory (cancelling protection in case of “OFF”) and indication of the display returns to “PrOt”.

• If the ESC key is pressed, the parameter writer returns to the status one before.

(*¹) Protecting operation of “SUP” is different from that provided for other memories and is shown below.

With the same inverter types (capacities):

SUP	Standard parameter	Special parameter
On	○	×
OFF	○	○

With different inverter types (capacities):

SUP	Standard parameter	Special parameter
On	○	×
OFF (Note)	×	×





○ Protection disabled
(write permitted)
× Write protected
(write prohibited)

Note: When inverter types (capacities) are different, copying operation of parameters (including special parameters) is prohibited.

4.5. Memory initializing function “CLR”

A selected memory (memory A, B, C or system memory of the parameter writer) or all of them, if selected, are initialized by this function.

Operating procedure

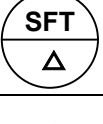
Key	LED indication	Key operation and description
—	“CHC” → “In It” → “COPY”	When the parameter writer is turned on as it is connected with the inverter, “CHC” appears on the display first and then “In It” appears to indicate that the power supply is being initialized. Lastly, the display shows “COPY”.
	“COPY” → “COMP” → “PrOt” → “CLR”	— Selecting a desired function — Select “CLR” (memory initializing function) with the SFT key. Each time the SFT key is pressed, indication on the display changes from “COPY” (copying function) to “COMP” (comparing function), “PrOt” (memory protecting function), “CLR” in this order.
	“CLR” → “A”	— Entering the selected function — After selecting “CLR” with the SFT key, press the ENT key and “A” (selecting memory A) appears on the display.
	“A” → “b” → “C” → “555” → “A”	— Selecting a memory to initialize — Select the desired memory to initialize with “SFT” key. Each time the SFT key is pressed, indication on the display changes from “A” (selecting memory A) to “b” (selecting memory B), “C” (selecting memory C), “555” (selecting all memories: status of factory setting (including “PrOt”)) in this order.
	“A” → “OFF”	— Entering the memory to initialize — After selecting “A” (selecting memory A, by way of example) with the SFT key, press the ENT key and “OFF” appears on the display.
	“OFF” → “On” → “OFF”	— Initializing the selected memory — Each time the SFT key is pressed, indication on the display alternately changes between “On” (to initialize selected memory) and “OFF” (not to initialize the selected memory).
	“On” → “In It” → “COPY”	— Executing initialization of the selected memory — After selecting “On” (selecting inverter's memory for example) with the SFT key, press the ENT key and the parameter writer starts initializing the selected memory with indication of “In It” appearing on the display. When initialization of the selected memory is complete, indication of the display returns to “COPY”.

- If the ESC key is pressed, the parameter writer returns to the status one before.

4.6. Function to serve as remote keypad

(for VF-S7/S7e series inverter whose CPU version is V104 or after)

The parameter writer can be used as an operation panel (remote keypad) of a VF-S7/S7e series inverter whose CPU version is V104 or after by means of the procedure mentioned below. For recovering the parameter writer's original function from the status to serve as remote keypad, do the same operation as that for actuating the remote keypad function. When the parameter writer is set to serve as a remote keypad, refer to the operation manual of the inverter for operations of the remote keypad because operations are the same as those on the inverter's operation panel.

- Procedure to switch the parameter writer's mode to function as a remote keypad or to function as parameter writer.

Following to the procedure of "3. Connection and start-up", turn on the parameter writer while pressing the  key.

- Checking the setting mode of the parameter writer (for remote keypad function or parameter writer function)

When the parameter writer is turned on and the PARAMETER WRITER lamp is on, the parameter writer is set to function as the parameter writer. When the REMOTE KEYPAD lamp is on, the parameter writer is set to function as the remote keypad.

5. Indications on display

Messages appearing on the display are classified into three, namely, title indications, malfunction indications and alarm indications.

■ Title indications (function indications): Indicated by LED lamps

LED indication	Description
<i>In It</i>	In initialization
<i>CHC</i>	In checking of initial communication with inverter
<i>COPY</i>	Copying function
<i>COMP</i>	Comparing function
<i>PrOt</i>	Memory protecting function
<i>CLr</i>	Memory initializing function
<i>A, b, C, In, SSS, SUP</i>	Name of objective memory <i>A</i> (memory A), <i>b</i> (memory B), <i>C</i> (memory C) <i>In</i> (inverter's memory), <i>SSS</i> (all memories), <i>SUP</i> (Special data)
<i>___ - ___</i>	Copying from ___ to ___
<i>___ = ___</i>	Comparing data of ___ with that of ___
<i>End</i>	End of copying or comparing
<i>OFF, On</i>	On/Off status of memory protection function or memory initializing function (ON: to execute, OFF: not to execute)
<i>F ___</i>	Communication number of parameter
<i>00 - FF</i>	Result of check sum (hexadecimal number)

■ Malfunction indications: Indicated by blinking LED

LED indication	Description
<i>r RnE</i>	RAM built in the parameter writer is abnormal. If the same indication appears after resetting the parameter writer, it needs to repair.
<i>r OnE</i>	ROM built in the parameter writer is abnormal. If the same indication appears after resetting the parameter writer, it needs to repair.
<i>EEPE</i>	E ² PROM built in the parameter writer is abnormal. If the same indication appears after writing (copying) data again, it needs to repair.
<i>CPUE</i>	CPU of the parameter writer is abnormal. If the same indication appears after resetting the parameter writer, it needs to repair.
<i>CO nE</i>	Abnormal communication When communication is normally operated after the indication, the alarm mode (indication) is automatically cancelled. If the same indication appears after checking connection of the inverter's serial communication cable and resetting the parameter writer, the unit needs to repair.

■ Alarm indications (warning indications): Indicated by blinking LED

LED indication	Description
<i>PrOt</i>	The target memory to copy data or to initialize is write protected. You cannot copy data to the memory or initialize that memory.
<i>dE uE</i>	The type of device is different (different in type or capacity of inverter). If you press the ENT key when you are copying between two inverters of different capacities, the system executes a copying operation forcefully but the system ends the operation if you press the ESC key. If you set "SSS" (system area parameters) to "OFF" (protection disabled) with "PrOt" (memory protection) function, you cannot write data even if you press the ENT key. If you have written data forcefully between two inverters with different capacities, we suggest you execute a parameter initialization for each level of inverter capacity. See the inverter instruction manual on how to initialize parameters.
<i>E r r.A</i> <i>E r r.b</i> <i>E r r.C</i>	When memory A (or B or C) is selected as the source of copying operation or when it is selected with comparison and protection functions with no data in either case in the memory (including the case when power was turned off during the previous copying operation), or when a check sum error occurred, this indication appears. Write data other than zero to the memory.
<i>F ___</i>	Indicates the communication number of the parameter whose setting value is different.
<i>CLr</i>	If you press the "STOP key" while an alarm message is displayed, "CLr" flickers for one second. If you press the "STOP key" again when "CLr" flickers, the parameter writer will be reset.

6. Resetting function

Reset the computer inside the parameter writer as follows if an alarm occurs.

[Resetting method]

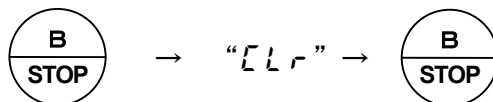

If “STOP key” is pressed while an alarm message is displayed, “L r” flickers for one second. If you press the “STOP key” again when “L r” flickers, the parameter writer will be reset.

7. Specifications

Item	Specifications
Model	PWU001Z-1
Service environment	Indoor lower than 1000m above sea level, not subject to direct sunlight, corrosive or explosive gas, vapor, dust, chips, cutting oil, grinding agent, etc.
Ambient temperature	-10°C to +50°C
Storage temperature	-25°C to +65°C
Relative humidity	20 to 90 % (no condensation allowed)
Vibration	5.9 m/s ²
Cooling	Self cooling

8. Warranty

The Parameter Writer will be adjusted or repaired free of charge under the following conditions.

1. When the Parameter Writer has a trouble under correct installation and operation within one year after delivery and the trouble clearly originated in the design or manufacture of the unit, the manufacturer is responsible for the trouble and the unit will be repaired by it free of charge.
2. The warranty applies to the delivered Parameter Writer only.
3. The user will be charged for the following repair service though the term of the warranty is not expired.
 - 1) Trouble or damage caused by wrong operation, unauthorized repair or modification.
 - 2) Trouble or damage caused by transportation, dropping or wrong handling of the unit after it was delivered to the user.
 - 3) Trouble or damage caused by fire, salt water/breezes, noxious gas, earthquake, flood or strong wind, lightning, abnormal mains voltage or other natural calamity.
 - 4) Trouble or damage caused by wrong use of the unit as it is used for a purpose other than the original application of the Parameter Writer.
4. In the case there is another warranty specially provided for the unit, it has priority over the above-mentioned articles.

