

# BS Servo Motor

## **BS Servo V Series**

Standard type	1500min <sup>-1</sup>	500W ~ 7.5kW
Standard type	3000min <sup>-1</sup>	1kW ~ 10kW
ZA type	3000min <sup>-1</sup>	30W ~ 750W
ZA type	1500min <sup>-1</sup>	11kW, 14kW

## **BS Servo G Series**

Standard type	2000min <sup>-1</sup>	20kW, 33kW, 55kW
---------------	-----------------------	------------------

## **BS Servo T Series**

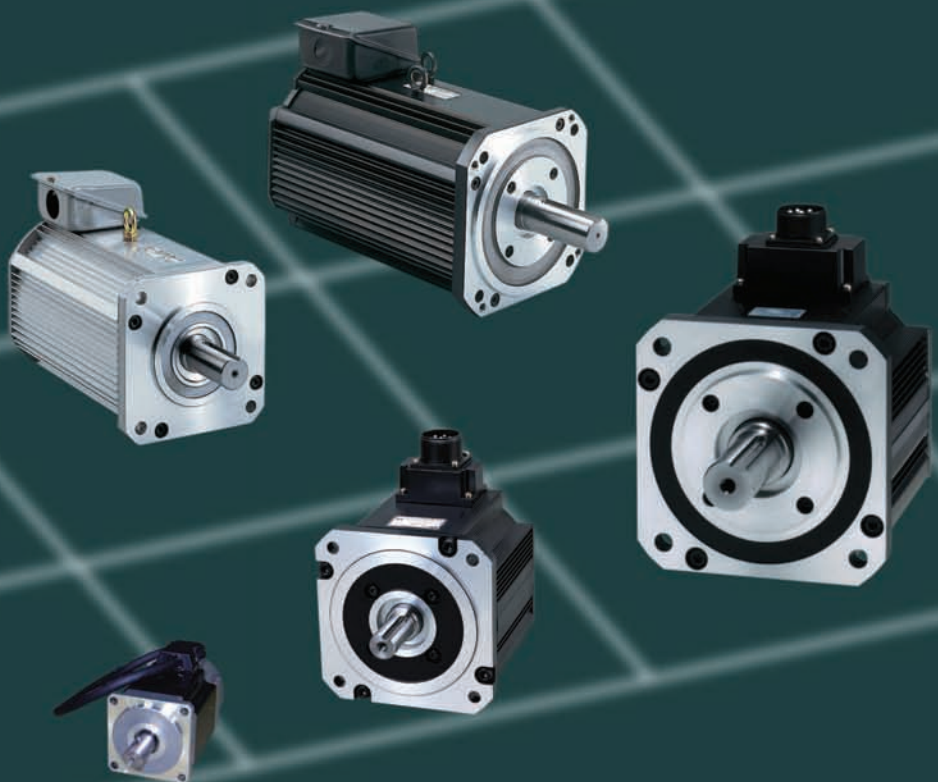

Standard type	1500min <sup>-1</sup>	400W ~ 5kW
Standard type	2000min <sup>-1</sup>	7.5kW, 10kW
Standard type	3000min <sup>-1</sup>	500W ~ 6.5kW



Assures high performance when used together with X series amplifier.

# BS Servo Motor

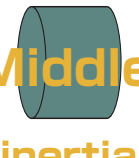
The BS servo motor control ability can improve when it is combined with the X series servo amplifier. The small-sized ZA type maintains high output power and high rigidity in spite of its compact structure. The large-sized ZA type motor comes in 11 kW and 14 kW rated output power types, and an array of 20 kW, 33 kW and 55 kW types is available for the large-sized G series. A broad variety of V series and T series standard motors are lined up according to users' applications to allow them to select the best one.

Class	Series	Type	Rated output [W]	Rated/Max. speed [min <sup>-1</sup> ]	Method of protection				
 <p>LOW inertia</p>	V	ZA	30	3000/5000	IP65				
			50						
			100						
			200						
			400						
			600						
			750						
	T	Std.	400	1500/2000	IP44 IP54 (CE-Marking)				
			800						
			1.0k						
			1.5k						
			2.6k						
			3.7k						
			5.0k						
			7.5k	2000/2500					
			10k						
			500	3000/4000					
800									
1.4k									
1.8k									
2.4k									
3.7k									
5.5k									
6.5k									
 <p>Middle inertia</p>	V	Std.	500	1500/2000	IP65				
			1.0k						
			1.5k						
			2.0k						
			3.0k						
			5.0k						
			7.5k						
			1.0k	3000/4000					
			1.8k						
			2.4k						
			3.0k						
			4.5k						
			7.0k						
			10k						
			 <p>Large-sized</p>	G		ZA Std.	11k	1500/2000	IP44
							14k	1500/1800	
	20k	2000/2200							
33k									
55k									

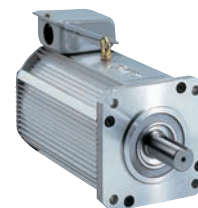

## Power rate setting according to machine characteristics

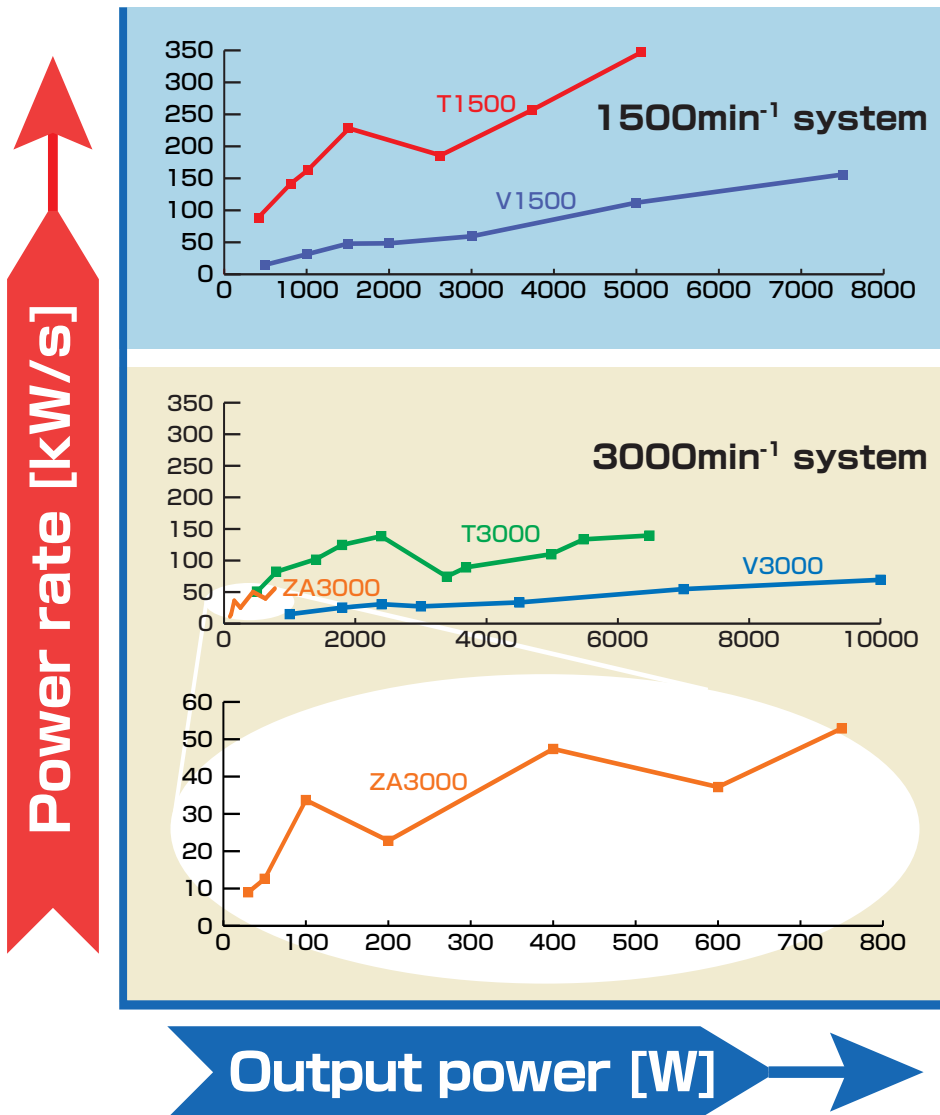

The T series standard type has low inertia and large torque. It is suited for the machine requiring quick response and acceleration/deceleration repeated very frequently.

The V series standard type has large inertia, thus stable rotation and high rigidity can be assured.

The V series ZA type is the small-capacity motor whose power rate succeeds the power rate characteristic of the T series 3000 min<sup>-1</sup> system.

Output power [W]

## How to identify motor model number

VL BS □-□□□□□□ 15□□-□ □□□

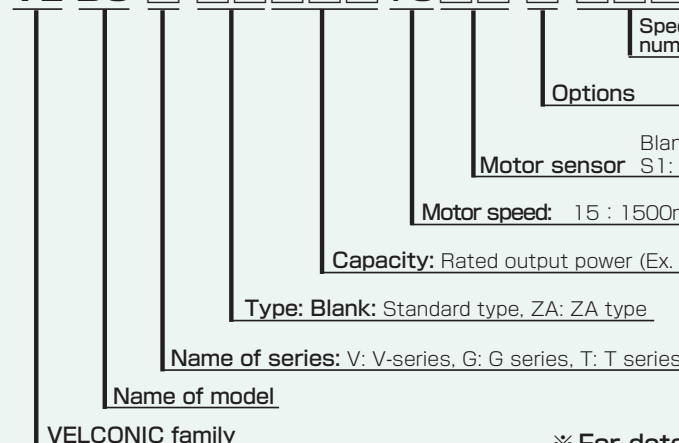

B : Brake  
 G : Reduction gear  
 K : Straight shaft without key  
 O : Oil seal  
 T : Taper shaft  
 ※The contents of options differ with the series.

※ For details, see the descriptions on each motor model.

## Standard Type 1500 min<sup>-1</sup>: Characteristics (Middle Inertia)

- Time rating: Continuous    ● Class of insulation: F    ● Ambient temperature: -10~+40℃    ● Class of vibration: V15
- Method of excitation: Permanent magnet    ● Method of protection: Totally-enclosed foam-proof (excluding shaft through area) IP65    ● Mounting method: Flange mounted type

Item \ Model		VLBSV-						
		05015	10015	15015	20015	30015	50015	75015
Rated output	W	500	1000	1500	2000	3000	5000	7500
Rated torque	N·m	3.18	6.37	9.55	12.7	19.1 31.8		47.8
Rated speed	min <sup>-1</sup>	1500						
Max. speed	min <sup>-1</sup>	2000						
Power rate	kW/s	15	31.4	48	48.5	59.5	112	156
Moment of inertia	X10 <sup>-4</sup> kg·m <sup>2</sup>	6.76	12.9	19.0	33.4	61.3	90.8	146
Momentary max. torque	N·m	9.55	19.1	28.6	38	48	80	140
Momentary max. current	A <sub>(rms)</sub>	7.9	15.8	24.7	41	49.5	71	141
Rated voltage	V <sub>(rms)</sub>	130	126	120	127	112	122	116
Rated current	A <sub>(rms)</sub>	2.6	5.2	8.1	11.7	17.9	27.8	42.5
Torque constant	N·m/A <sub>(rms)</sub>	1.23	1.23	1.18	1.09	1.07	1.15	1.12
Heat time constant	min	15	17	20	34	40	45	55
Coil resistance	Ω	4.75	1.72	0.96	0.55	0.21	0.13	0.071
Coil inductance	mH	23.4	10.2	6.4	10.9	4.66	3.54	2.01
Induced voltage constant	V <sub>(rms)</sub> /min <sup>-1</sup>	0.0767	0.0767	0.0733	0.0673	0.066	0.0707	0.0693
Permissible thrust load	N	127	127	127	323	323	323	323
Permissible radial load	N	510	578	637	1333	1480	1470	1617
Mass	kg	5.5	7.5	9.8	15.5	22	29.5	42.5
Applicable servo amplifier	012P2	○						
	035P3		○	○				
	070P3				○	○		
	VLASV-VL□□X-						○	
	200P3							○

The maximum torque is obtained when the motor is used in combination with the standard BS servo amplifier. (For any combination other than the standard one, consult with us.)

Designed for UL/CE-Marking



IEC34-1/EN60034-1

Standard relating to general motors  
(International standard/EU)

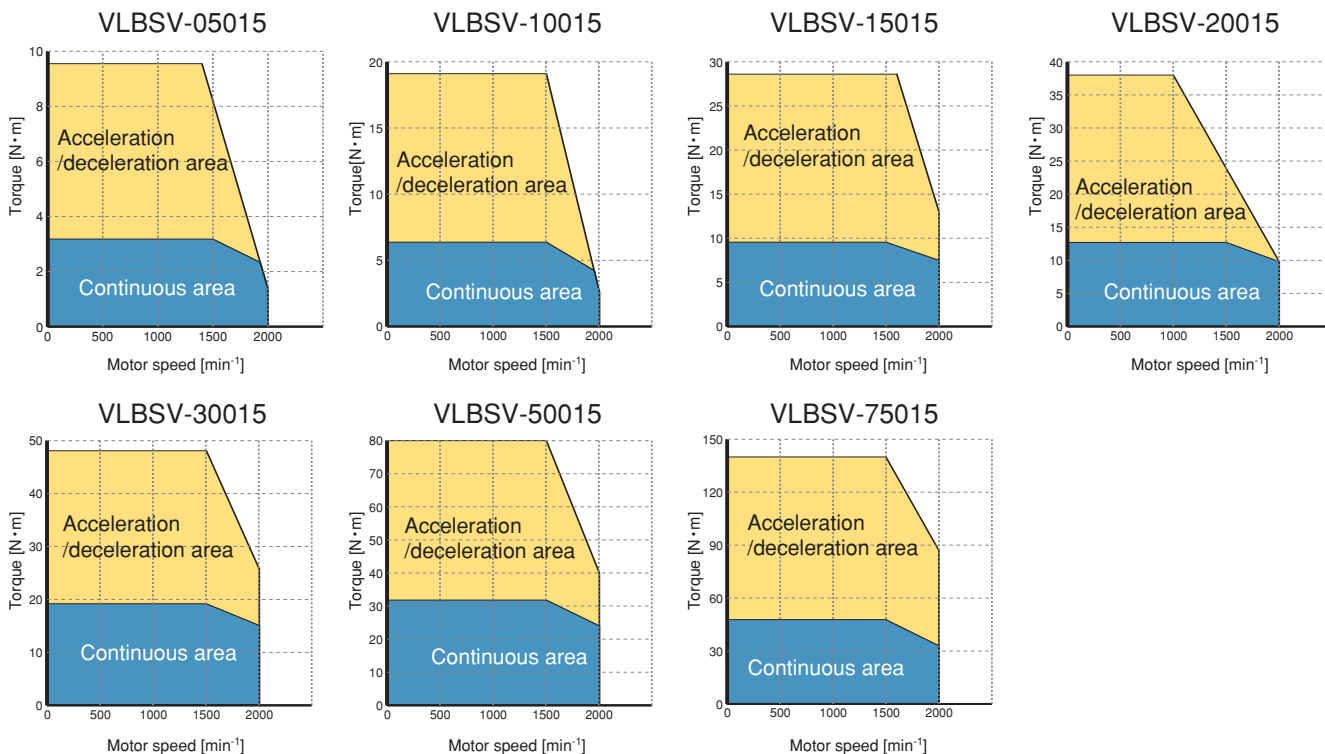

### **B** Brake (holding brake)

The brake of the servo motor is a slim type dry non-excited electromagnetic brake. Use it for preventing the vertical shaft from falling and for holding the horizontal shaft at power OFF.

### **G** Reduction gear

The V series servo motor uses an Able reduction gear, HPG series reduction gear or Coronet reduction gear. For detailed specifications, consult with us.

### **K** Straight shaft without key

This shaft does not have any keyway and is the same as the standard shaft in diameter and length.

### **O** Oil seal

If oil of the output shaft will splash from the machine side, use of an oil seal is recommended.

### **T** Taper shaft

The servo motor is standardly provided with straight shaft with key. A taper shaft is available optionally.

### V series motor model (standard 1500 min<sup>-1</sup>)

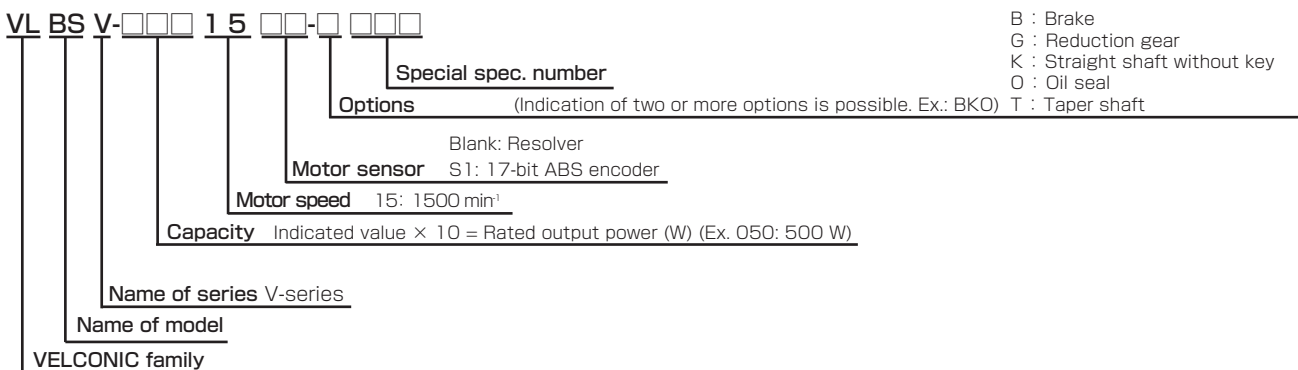

# Standard Type 1500 min<sup>-1</sup>: Outer Dimensions (Resolver Specifications)

## VLBSV-05015 • 10015 • 15015

Standard type

With brake

Type	L	LL	LM	LR	φ S	Q	QK	W	T	U	Shaft end tap	Hook bolt
05015	186	141	102	45	19h6	40	36	6h9	6	3.5	M6 P1.0 depth 16	Not provided
10015	211	166	127	45	19h6	40	36	6h9	6	3.5	M6 P1.0 depth 16	Not provided
15015	246	191	152	55	24h6	50	45	8h9	7	4	M8 P1.25 depth 20	Not provided
05015-B	228	183	144	45	19h6	40	36	6h9	6	3.5	M6 P1.0 depth 16	Not provided
10015-B	253	208	169	45	19h6	40	36	6h9	6	3.5	M6 P1.0 depth 16	Not provided
15015-B	288	233	194	55	24h6	50	45	8h9	7	4	M8 P1.25 depth 20	Not provided

Details of shaft end

## VLBSV-20015 • 30015

Standard type

With brake

Type	L	LL	LM	LR	φ S	Q	QK	W	T	U	Shaft end tap	Hook bolt
20015	277	198	159	79	35 <sup>+0.01</sup> <sub>0</sub>	72	60	10h9	8	5	M10 P1.5 depth 20	Not provided
30015	321	242	203	79	35 <sup>+0.01</sup> <sub>0</sub>	72	60	10h9	8	5	M10 P1.5 depth 20	Not provided
20015-B	345	266	227	79	35 <sup>+0.01</sup> <sub>0</sub>	72	60	10h9	8	5	M10 P1.5 depth 20	Not provided
30015-B	389	310	271	79	35 <sup>+0.01</sup> <sub>0</sub>	72	60	10h9	8	5	M10 P1.5 depth 20	Not provided

Details of shaft end

## VLBSV-50015 • 75015

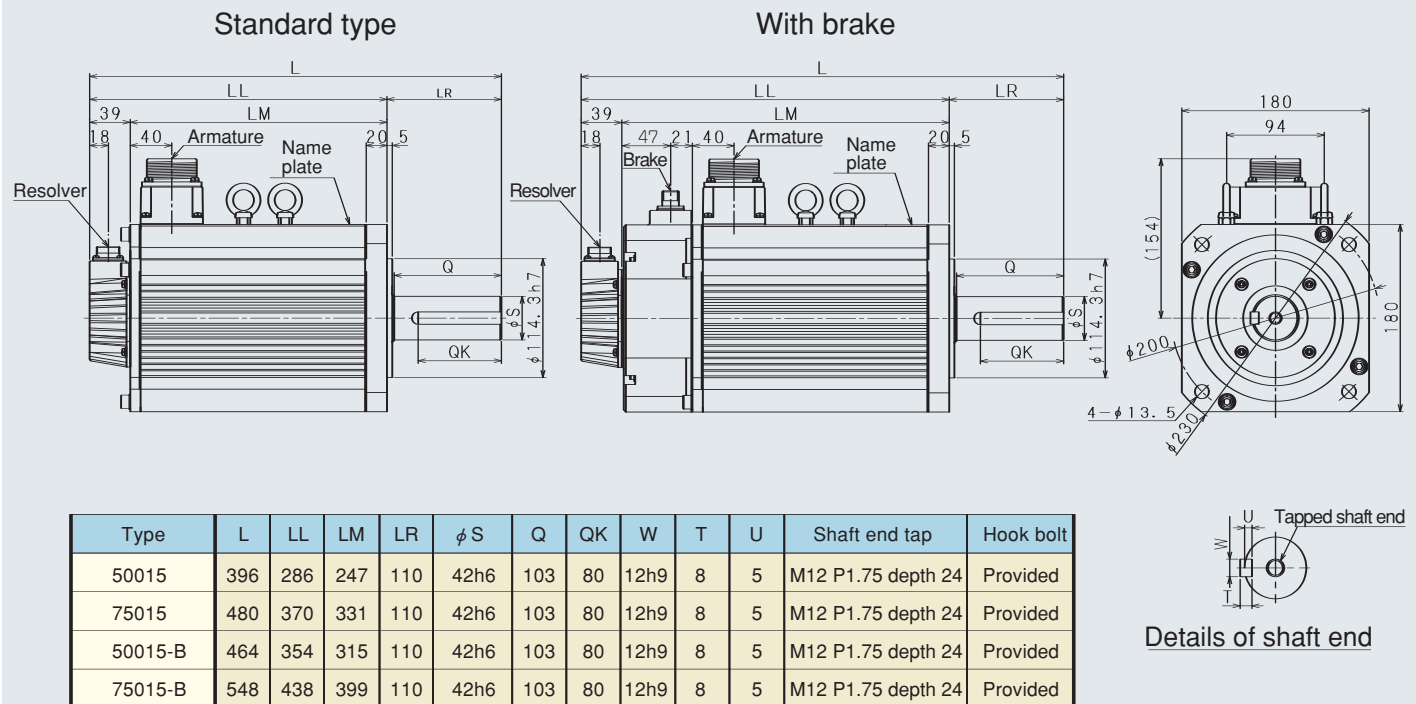

## Armature plug selection table

Neither plug nor cable clamp is attached, which are available for extra prices.

Type of motor	Receptacle	Straight plug	Cable clamp	Recommended cabtyre cable dia.
VLBSV-05015	JL04V-2E20-15PE-B-R	JL04V-6A20-15SE-EB-R	JL04-2022CK(09)-R	φ 6.5~ φ 9.5
VLBSV-10015	JL04V-2E20-15PE-B-R	JL04V-6A20-15SE-EB-R	JL04-2022CK(09)-R	φ 6.5~ φ 9.5
VLBSV-15015	JL04V-2E20-15PE-B-R	JL04V-6A20-15SE-EB-R	JL04-2022CK(09)-R	φ 6.5~ φ 9.5
VLBSV-20015	JL04V-2E24-10PE-B-R	JL04V-6A24-10SE-EB-R	JL04-2428CK(14)-R	φ 12~ φ 15
VLBSV-30015	JL04V-2E24-10PE-B-R	JL04V-6A24-10SE-EB-R	JL04-2428CK(14)-R	φ 12~ φ 15
VLBSV-50015	JL04V-2E32-17PE-B-R	JL04V-6A32-17SE-R	ACS-20RL-MS32F	φ 16~ φ 20
VLBSV-75015	JL04V-2E32-17PE-B-R	JL04V-6A32-17SE-R	ACS-20RL-MS32F	φ 16~ φ 20
For brake only	JL04V-2E10SL-3PE-B-R	JL04V-6A10SL-3SE-EB-R	ACS-08RL-MS10F	φ 4~ φ 8

## Brake performance table

The rotor inertia and mass are the values of a single brake, excluding those of the motor.

Applicable motor	Static friction torque N·m	Rotor inertia ×10 <sup>-4</sup> kg·m <sup>2</sup>	Coil (20°C)				Suction time ms	Release time ms	Mass kg
			Voltage	Current	Resistance	Capacity			
			DC V	A	Ω	W			
05015	7.84	0.675	24	0.63	38	15	55	15	2.0
10015									
15015									
20015	15.7	2.85	24	0.76	32	18	70	25	2.7
30015									
50015									
75015	49	5.75	24	1.13	21	27	120	50	7.0

## V Series Standard Type 1500 min<sup>-1</sup>: Outer Dimensions (Encoder Specifications)

### VLBSV-05015S1 • 10015S1 • 15015S1

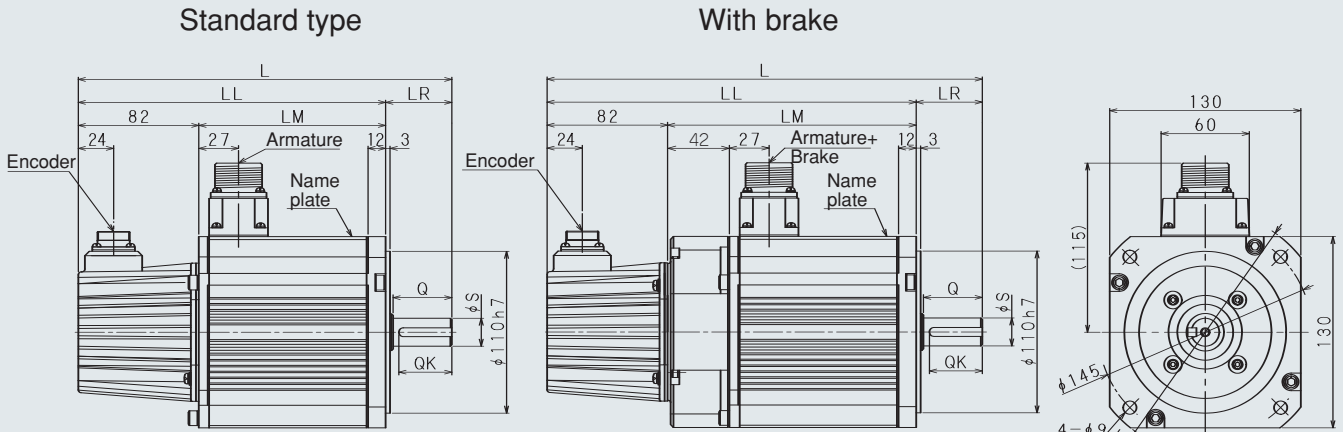

Type	L	LL	LM	LR	φ S	Q	QK	W	T	U	Shaft end tap	Hook bolt
05015S1	229	184	102	45	19h6	40	36	6h9	6	3.5	M6 P1.0 depth 16	Not provided
10015S1	254	209	127	45	19h6	40	36	6h9	6	3.5	M6 P1.0 depth 16	Not provided
15015S1	289	234	152	55	24h6	50	45	8h9	7	4	M8 P1.25 depth 20	Not provided
05015S1-B	271	226	144	45	19h6	40	36	6h9	6	3.5	M6 P1.0 depth 16	Not provided
10015S1-B	296	251	169	45	19h6	40	36	6h9	6	3.5	M6 P1.0 depth 16	Not provided
15015S1-B	331	276	194	55	24h6	50	45	8h9	7	4	M8 P1.25 depth 20	Not provided

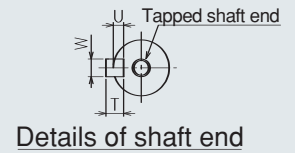

### VLBSV-20015S1 • 30015S1

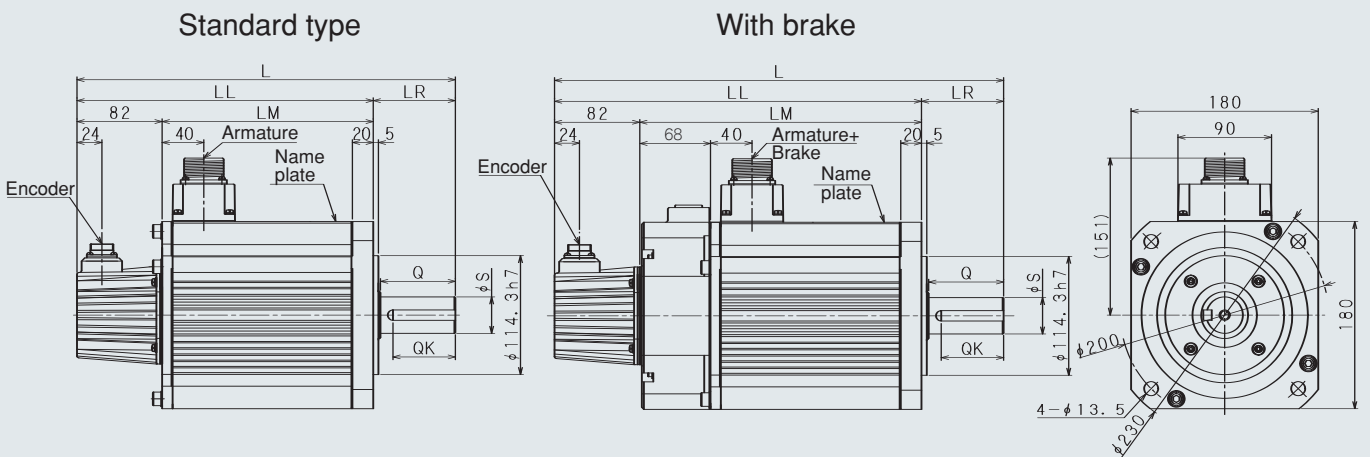

Type	L	LL	LM	LR	φ S	Q	QK	W	T	U	Shaft end tap	Hook bolt
20015S1	320	241	159	79	35 <sup>+0.01</sup> <sub>0</sub>	72	60	10h9	8	5	M10 P1.5 depth 20	Not provided
30015S1	364	285	203	79	35 <sup>+0.01</sup> <sub>0</sub>	72	60	10h9	8	5	M10 P1.5 depth 20	Not provided
20015S1-B	388	309	227	79	35 <sup>+0.01</sup> <sub>0</sub>	72	60	10h9	8	5	M10 P1.5 depth 20	Not provided
30015S1-B	432	353	271	79	35 <sup>+0.01</sup> <sub>0</sub>	72	60	10h9	8	5	M10 P1.5 depth 20	Not provided

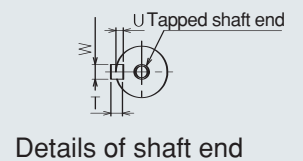

**VLBSV-50015S1 • 75015S1**

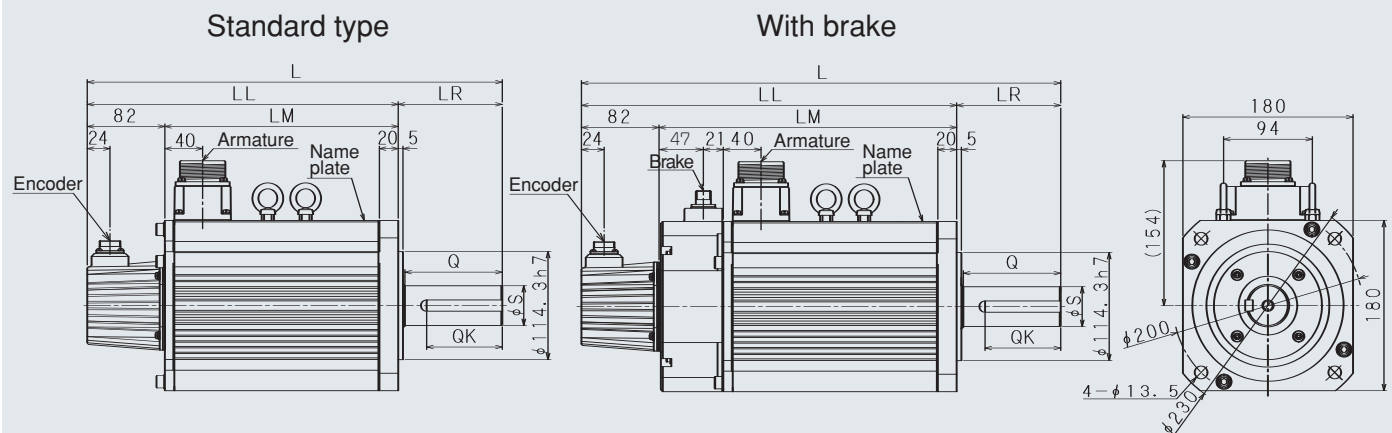

Type	L	LL	LM	LR	φ S	Q	QK	W	T	U	Shaft end tap	Hook bolt
50015S1	439	329	247	110	42h6	103	80	12h9	8	5	M12 P1.75 depth 24	Provided
75015S1	523	413	331	110	42h6	103	80	12h9	8	5	M12 P1.75 depth 24	Provided
50015S1-B	507	397	315	110	42h6	103	80	12h9	8	5	M12 P1.75 depth 24	Provided
75015S1-B	591	481	399	110	42h6	103	80	12h9	8	5	M12 P1.75 depth 24	Provided

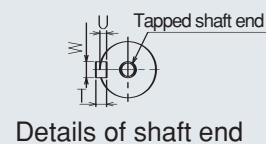

**Armature plug selection table** Neither plug nor cable clamp is attached, which are available for extra prices.

Type of motor	Receptacle	Straight plug	Cable clamp	Recommended cabtyre cable dia.
VLBSV-05015S1	JL04V-2E20-15PE-B-R	JL04V-6A20-15SE-EB-R	JL04-2022CK(09)-R	φ 6.5~ φ 9.5
VLBSV-10015S1	JL04V-2E20-15PE-B-R	JL04V-6A20-15SE-EB-R	JL04-2022CK(09)-R	φ 6.5~ φ 9.5
VLBSV-15015S1	JL04V-2E20-15PE-B-R	JL04V-6A20-15SE-EB-R	JL04-2022CK(09)-R	φ 6.5~ φ 9.5
VLBSV-20015S1	JL04V-2E24-10PE-B-R	JL04V-6A24-10SE-EB-R	JL04-2428CK(14)-R	φ 12~ φ 15
VLBSV-30015S1	JL04V-2E24-10PE-B-R	JL04V-6A24-10SE-EB-R	JL04-2428CK(14)-R	φ 12~ φ 15
VLBSV-50015S1	JL04V-2E32-17PE-B-R	JL04V-6A32-17SE-R	ACS-20RL-MS32F	φ 16~ φ 20
VLBSV-75015S1	JL04V-2E32-17PE-B-R	JL04V-6A32-17SE-R	ACS-20RL-MS32F	φ 16~ φ 20
For brake only	JL04V-2E10SL-3PE-B-R	JL04V-6A10SL-3SE-EB-R	ACS-08RL-MS10F	φ 4~ φ 8

**Brake performance table** The rotor inertia and mass are the values of a single brake, excluding those of the motor.

Applicable motor	Static friction torque N·m	Rotor inertia ×10 <sup>4</sup> kg·m <sup>2</sup>	Coil (20°C)				Suction time ms	Release time ms	Mass kg
			Voltage	Current	Resistance	Capacity			
			DC V	A	Ω	W			
05015S1	7.84	0.675	24	0.63	38	15	55	15	2.0
10015S1									
15015S1									
20015S1	15.7	2.85	24	0.76	32	18	70	25	2.7
30015S1									
50015S1	29.4	3.0	24	0.96	25	23	100	35	4.4
75015S1	49	5.75	24	1.13	21	27	120	50	7.0

## V Series Standard Type 3000 min<sup>-1</sup>: Characteristics (Middle Inertia)

- Time rating: Continuous    ● Class of insulation: F    ● Ambient temperature: -10~+40°C    ● Class of vibration: V15
- Method of excitation: Permanent magnet    ● Method of protection: Totally-enclosed foam-proof (excluding shaft through area) IP65    ● Mounting method: Flange mounted type

Model		VLBSV-						
		10030	18030	24030	30030	45030	70030	10K30
Rated output	W	1000	1800	2400	3000	4500	7000	10000
Rated torque	N·m	3.18	5.73	7.64	9.55	14.3	22.3	31.8
Rated speed	min <sup>-1</sup>	3000						
Max. speed	min <sup>-1</sup>	4000						
Power rate	kW/s	15	25.4	30.7	27.3	33.5	54.7	69.4
Moment of inertia	X10 <sup>-4</sup> kg·m <sup>2</sup>	6.76	12.9	19.0	33.4	61.3	90.8	146
Momentary max. torque	N·m	9.55	17.2	22.9	29	40	66	77
Momentary max. current	A <sub>(rms)</sub>	16.2	29.6	40.6	49.5	71	122	141
Rated voltage	V <sub>(rms)</sub>	125	119	115	131	118	110	109
Rated current	A <sub>(rms)</sub>	5.3	9.7	13.3	15.2	24.1	40	56.6
Torque constant	N·m/A <sub>(rms)</sub>	0.6	0.593	0.576	0.627	0.594	0.557	0.562
Heat time constant	min	15	17	20	34	40	45	55
Coil resistance	Ω	1.22	0.41	0.24	0.19	0.075	0.04	0.018
Coil inductance	mH	5.8	2.5	1.5	3.36	1.46	0.83	0.505
Induced voltage constant	V <sub>(rms)</sub> /min <sup>-1</sup>	0.0383	0.0377	0.0367	0.0387	0.0367	0.0343	0.0347
Permissible thrust load	N	108	108	108	274	274	274	274
Permissible radial load	N	402	461	500	1058	1176	1166	1284
Mass	kg	5.5	7.5	9.8	15.5	22	29.5	42.5
Applicable servo amplifier	012P2							
	035P3	○						
	070P3		○	○	○			
	100P3					○		
	200P3						○	○

The maximum torque is obtained when the motor is used in combination with the standard BS servo amplifier. (For any combination other than the standard one, consult with us.)

Designed for UL/CE-Marking



IEC34-1/EN60034-1  
Standard relating to general motors  
(International standard/EU)

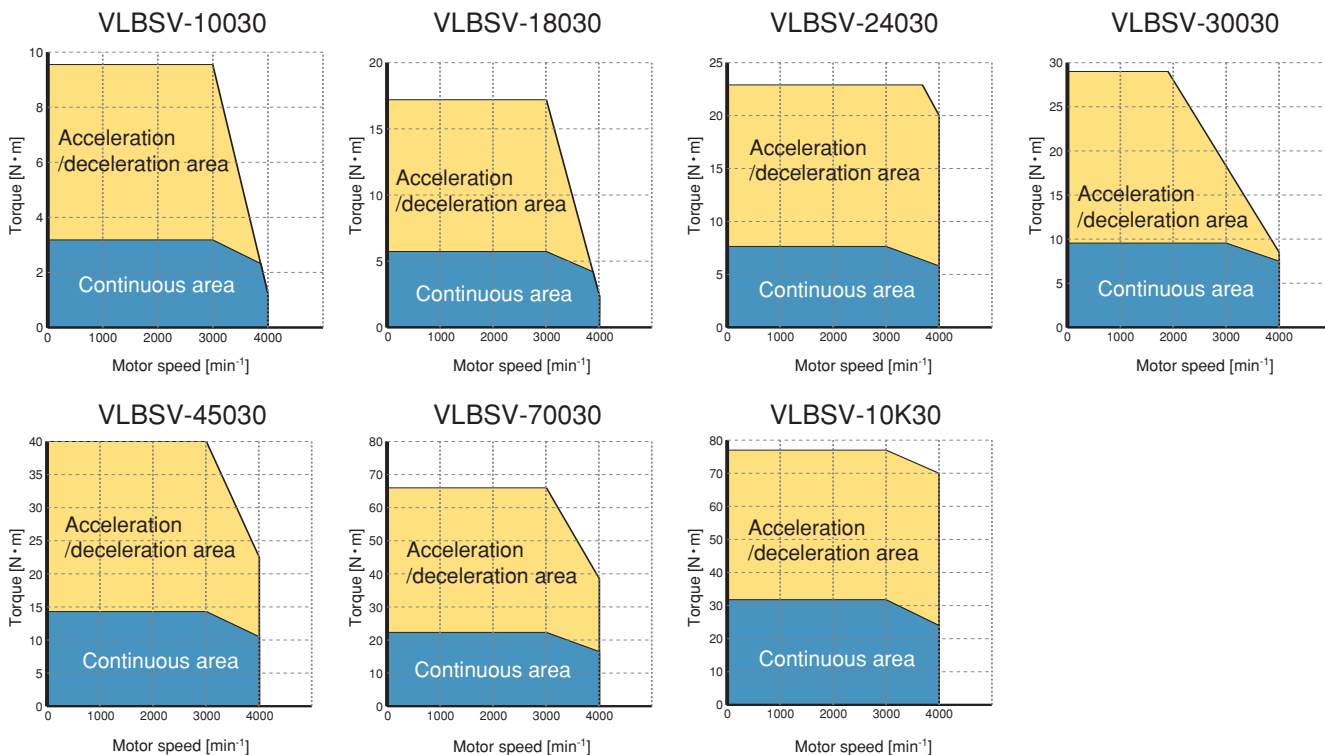

**B Brake (holding brake)**

The brake of the servo motor is a slim type dry non-excited electromagnetic brake. Use it for preventing the vertical shaft from falling and for holding the horizontal shaft at power OFF.

**G Reduction gear**

The V series servo motor uses an Able reduction gear or HPG series reduction gear. For detailed specifications, consult with us.

**K Straight shaft without key**

This shaft does not have any keyway and is the same as the standard shaft in diameter and length.

**O Oil seal**

If oil of the output shaft will splash from the machine side, use of an oil seal is recommended.

**T Taper shaft**

The servo motor is standardly provided with straight shaft with key. A taper shaft is available optionally.

**V series motor model (standard 3000 min<sup>-1</sup>)**

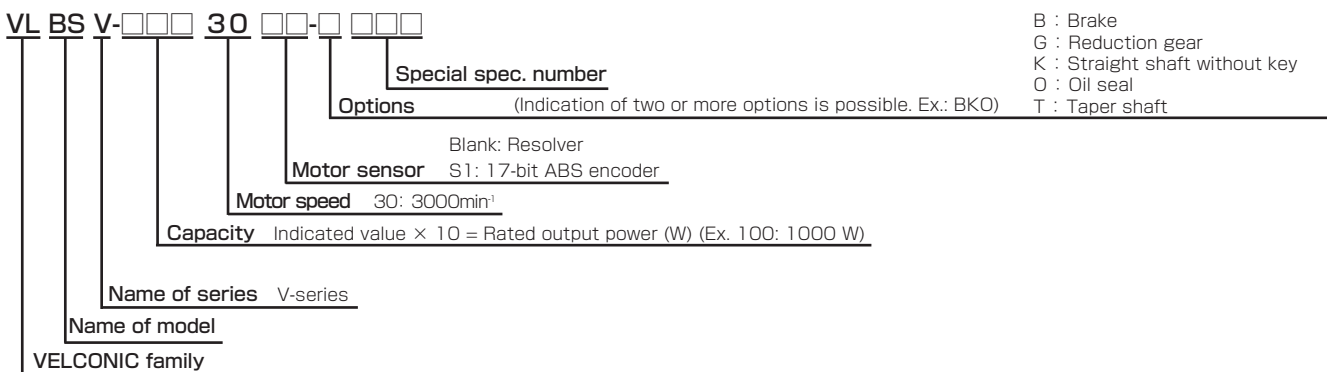

## V Series Standard Type 3000 min<sup>-1</sup>: Outer Dimensions (Resolver Specifications)

### VLBSV-10030 • 18030 • 24030

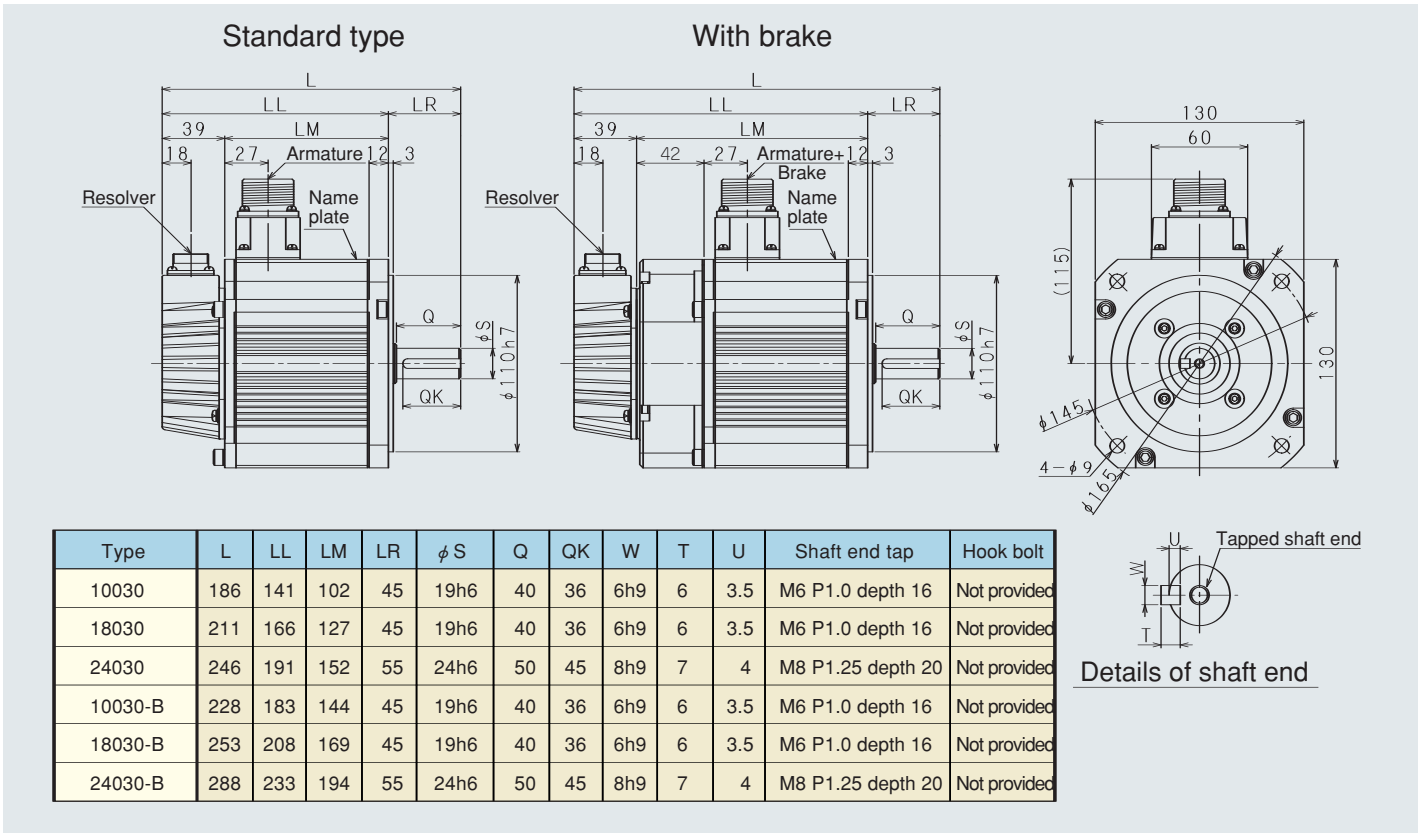

### VLBSV-30030 • 45030

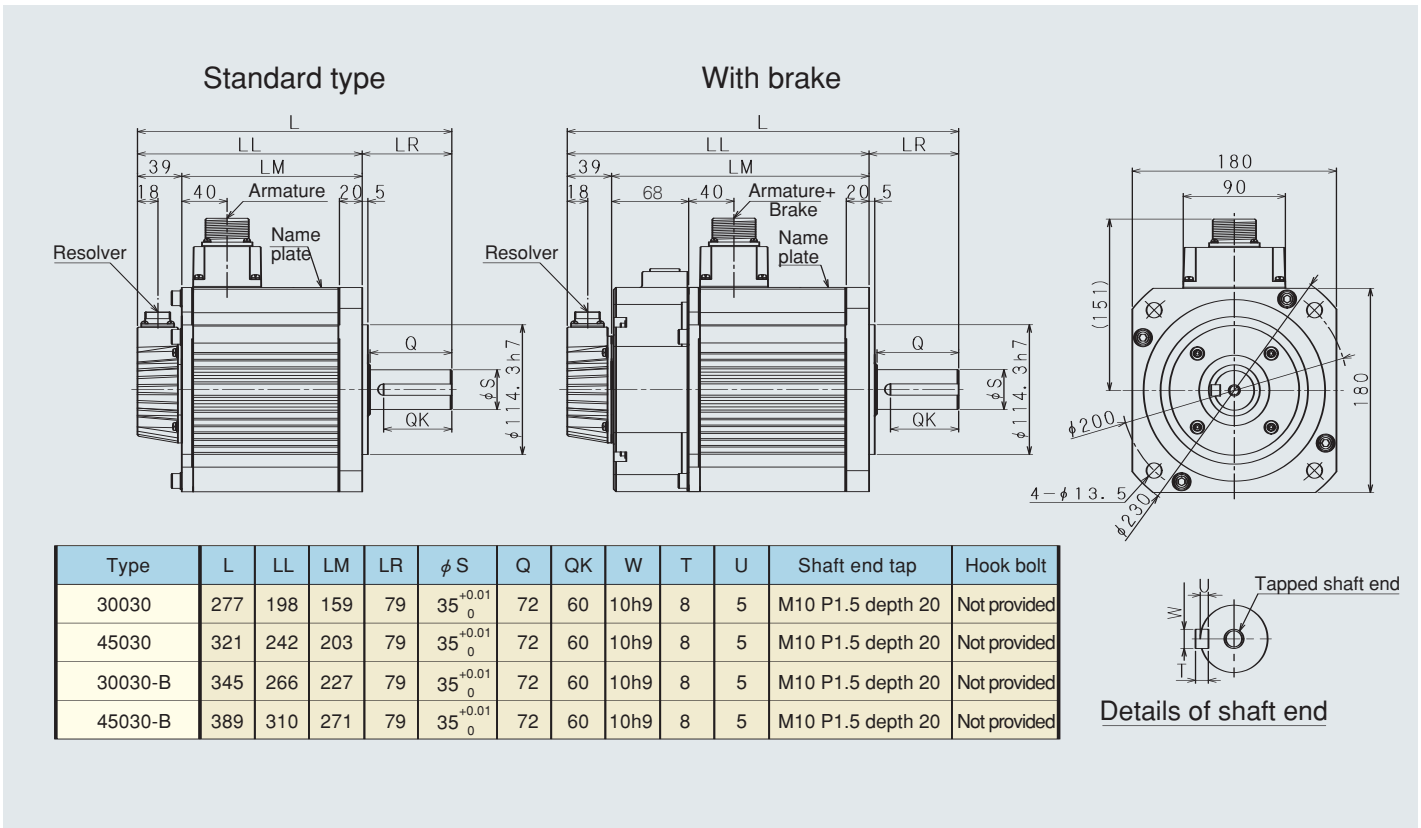

## VLBSV-70030 • 10K30

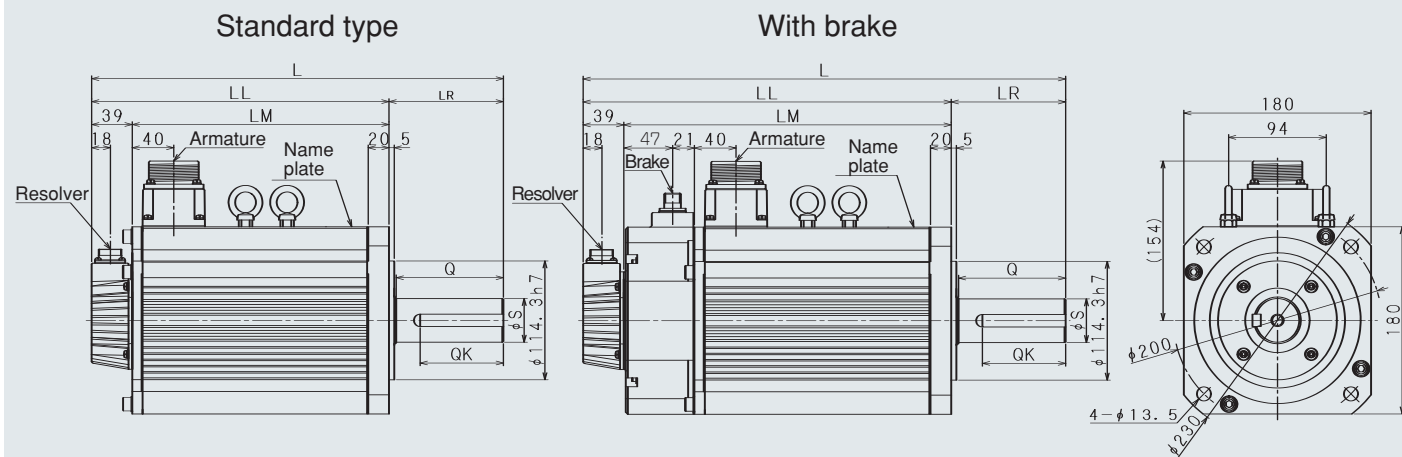

Type	L	LL	LM	LR	φ S	Q	QK	W	T	U	Shaft end tap	Hook bolt
70030	396	286	247	110	42h6	103	80	12h9	8	5	M12 P1.75 depth 24	Provided
10K30	480	370	331	110	42h6	103	80	12h9	8	5	M12 P1.75 depth 24	Provided
70030-B	464	354	315	110	42h6	103	80	12h9	8	5	M12 P1.75 depth 24	Provided
10K30-B	548	438	399	110	42h6	103	80	12h9	8	5	M12 P1.75 depth 24	Provided

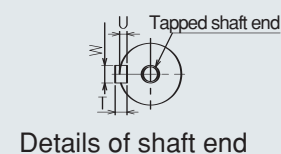

## Armature plug selection table

Neither plug nor cable clamp is attached, which are available for extra prices.

Type of motor	Receptacle	Straight plug	Cable clamp	Recommended cable dia.
VLBSV-10030	JL04V-2E20-15PE-B-R	JL04V-6A20-15SE-EB-R	JL04-2022CK(09)-R	φ 6.5~ φ 9.5
VLBSV-18030	JL04V-2E20-15PE-B-R	JL04V-6A20-15SE-EB-R	JL04-2022CK(09)-R	φ 6.5~ φ 9.5
VLBSV-24030	JL04V-2E20-15PE-B-R	JL04V-6A20-15SE-EB-R	JL04-2022CK(09)-R	φ 6.5~ φ 9.5
VLBSV-30030	JL04V-2E24-10PE-B-R	JL04V-6A24-10SE-EB-R	JL04-2428CK(14)-R	φ 12~ φ 15
VLBSV-45030	JL04V-2E24-10PE-B-R	JL04V-6A24-10SE-EB-R	JL04-2428CK(14)-R	φ 12~ φ 15
VLBSV-70030	JL04V-2E32-17PE-B-R	JL04V-6A32-17SE-R	ACS-20RL-MS32F	φ 16~ φ 20
VLBSV-10K30	JL04V-2E32-17PE-B-R	JL04V-6A32-17SE-R	ACS-20RL-MS32F	φ 16~ φ 20
For brake only	JL04V-2E10SL-3PE-B-R	JL04V-6A10SL-3SE-EB-R	ACS-08RL-MS10F	φ 4~ φ 8

## Brake performance table

The rotor inertia and mass are the values of a single brake, excluding those of the motor.

Applicable motor	Static friction torque N·m	Rotor inertia ×10 <sup>-4</sup> kg·m <sup>2</sup>	Coil (20°C)				Suction time ms	Release time ms	Mass kg
			Voltage	Current	Resistance	Capacity			
			DC V	A	Ω	W			
10030	7.84	0.675	24	0.63	38	15	55	15	2.0
18030									
24030									
30030	15.7	2.85	24	0.76	32	18	70	25	2.7
45030									
70030	29.4	3.0	24	0.96	25	23	100	35	4.4
10K30	49	5.75	24	1.13	21	27	120	50	7.0

# V Series Standard Type 3000 min<sup>-1</sup>: Outer Dimensions (Encoder Specifications)

## VLBSV-10030S1 • 18030S1 • 24030S1

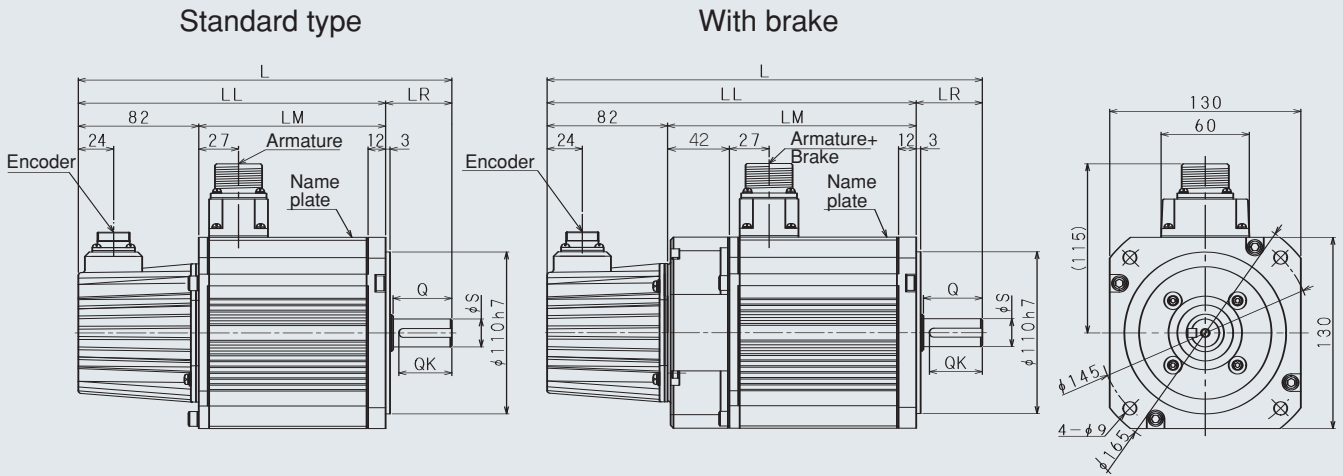

Type	L	LL	LM	LR	φ S	Q	QK	W	T	U	Shaft end tap	Hook bolt
10030S1	229	184	102	45	19h6	40	36	6h9	6	3.5	M6 P1.0 depth 16	Not provided
18030S1	254	209	127	45	19h6	40	36	6h9	6	3.5	M6 P1.0 depth 16	Not provided
24030S1	289	234	152	55	24h6	50	45	8h9	7	4	M8 P1.25 depth 20	Not provided
10030S1-B	271	226	144	45	19h6	40	36	6h9	6	3.5	M6 P1.0 depth 16	Not provided
18030S1-B	296	251	169	45	19h6	40	36	6h9	6	3.5	M6 P1.0 depth 16	Not provided
24030S1-B	331	276	194	55	24h6	50	45	8h9	7	4	M8 P1.25 depth 20	Not provided

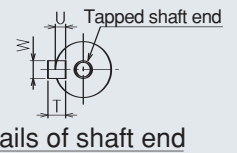

## VLBSV-30030S1 • 45030S1

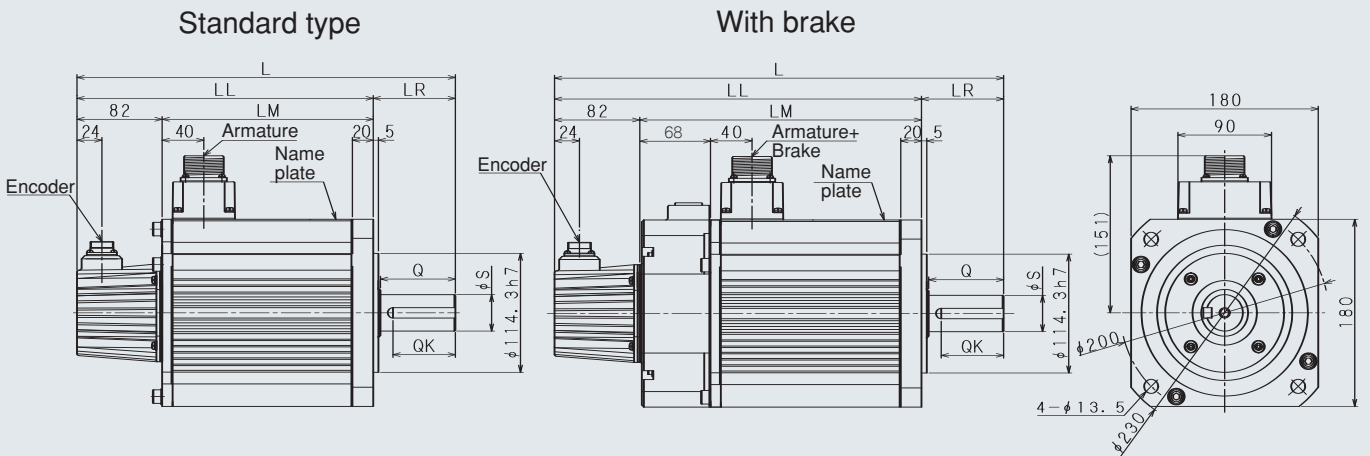

Type	L	LL	LM	LR	φ S	Q	QK	W	T	U	Shaft end tap	Hook bolt
30030S1	320	241	159	79	35 <sup>+0.01</sup> <sub>0</sub>	72	60	10h9	8	5	M10 P1.5 depth 20	Not provided
45030S1	364	285	203	79	35 <sup>+0.01</sup> <sub>0</sub>	72	60	10h9	8	5	M10 P1.5 depth 20	Not provided
30030S1-B	388	309	227	79	35 <sup>+0.01</sup> <sub>0</sub>	72	60	10h9	8	5	M10 P1.5 depth 20	Not provided
45030S1-B	432	353	271	79	35 <sup>+0.01</sup> <sub>0</sub>	72	60	10h9	8	5	M10 P1.5 depth 20	Not provided

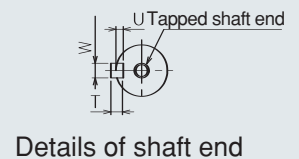

**VLBSV-70030S1 • 10K30S1**

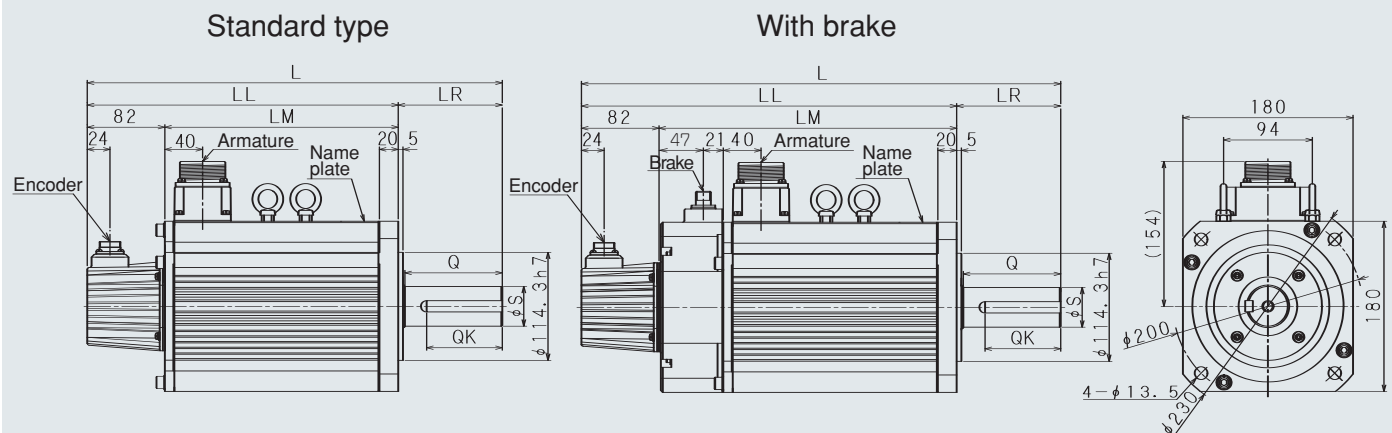

Type	L	LL	LM	LR	φ S	Q	QK	W	T	U	Shaft end tap	Hook bolt
70030S1	439	329	247	110	42h6	103	80	12h9	8	5	M12 P1.75 depth 24	Provided
10K30S1	523	413	331	110	42h6	103	80	12h9	8	5	M12 P1.75 depth 24	Provided
70030S1-B	507	397	315	110	42h6	103	80	12h9	8	5	M12 P1.75 depth 24	Provided
10K30S1-B	591	481	399	110	42h6	103	80	12h9	8	5	M12 P1.75 depth 24	Provided

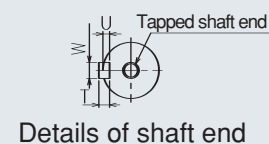

**Armature plug selection table** Neither plug nor cable clamp is attached, which are available for extra prices.

Type of motor	Receptacle	Straight plug	Cable clamp	Recommended cabtyre cable dia.
VLBSV-10030S1	JL04V-2E20-15PE-B-R	JL04V-6A20-15SE-EB-R	JL04-2022CK(09)-R	φ 6.5~ φ 9.5
VLBSV-18030S1	JL04V-2E20-15PE-B-R	JL04V-6A20-15SE-EB-R	JL04-2022CK(09)-R	φ 6.5~ φ 9.5
VLBSV-24030S1	JL04V-2E20-15PE-B-R	JL04V-6A20-15SE-EB-R	JL04-2022CK(09)-R	φ 6.5~ φ 9.5
VLBSV-30030S1	JL04V-2E24-10PE-B-R	JL04V-6A24-10SE-EB-R	JL04-2428CK(14)-R	φ 12~ φ 15
VLBSV-45030S1	JL04V-2E24-10PE-B-R	JL04V-6A24-10SE-EB-R	JL04-2428CK(14)-R	φ 12~ φ 15
VLBSV-70030S1	JL04V-2E32-17PE-B-R	JL04V-6A32-17SE-R	ACS-20RL-MS32F	φ 16~ φ 20
VLBSV-10K30S1	JL04V-2E32-17PE-B-R	JL04V-6A32-17SE-R	ACS-20RL-MS32F	φ 16~ φ 20
For brake only	JL04V-2E10SL-3PE-B-R	JL04V-6A10SL-3SE-EB-R	ACS-08RL-MS10F	φ 4~ φ 8

**Brake performance table** The rotor inertia and mass are the values of a single brake, excluding those of the motor.

Applicable motor	Static friction torque N·m	Rotor inertia ×10 <sup>-4</sup> kg·m <sup>2</sup>	Coil (20°C)				Suction time ms	Release time ms	Mass kg
			Voltage	Current	Resistance	Capacity			
			DC V	A	Ω	W			
10030S1	7.84	0.675	24	0.63	38	15	55	15	2.0
18030S1									
24030S1									
30030S1	15.7	2.85	24	0.76	32	18	70	25	2.7
45030S1									
70030S1	29.4	3.0	24	0.96	25	23	100	35	4.4
10K30S1	49	5.75	24	1.13	21	27	120	50	7.0

## V Series ZA Type 3000 min<sup>-1</sup>: Characteristics (Low Inertia)

- ◆ Time rating: Continuous    ◆ Class of insulation: F    ◆ Ambient temperature: 0~+40℃    ◆ Class of vibration: V15
- ◆ Method of excitation: Permanent magnet    ◆ Method of protection: Totally-enclosed foam-proof (excluding shaft through area and connector) IP65    ◆ Mounting method: Flange mounted type

Item \ Model		VLBSV-						
		ZA00330	ZA00530	ZA01030	ZA02030	ZA04030	ZA06030	ZA07530
Rated output	W	30	50	100	200	400	600	750
Rated torque	N·m	0.095	0.159	0.318	0.64	1.27	1.91	2.39
Rated speed	min <sup>-1</sup>	3000						
Max. speed	min <sup>-1</sup>	5000						
Power rate	kW/s	9.0	12.6	33.7	22.8	47.4	37.2	52.9
Moment of inertia	X10 <sup>-4</sup> kg·m <sup>2</sup>	0.01	0.02	0.03	0.18	0.34	0.98	1.08
Momentary max. torque	N·m	0.25	0.4	0.86	1.52	2.99	5.07	6.27
Momentary max. current	A <sub>(rms)</sub>	0.9	1.5	3	4.5	8.5	12.6	14.1
Rated voltage	V <sub>(rms)</sub>	97	77	75	85	84	89	99
Rated current	A <sub>(rms)</sub>	0.31	0.65	1.1	1.84	3.4	4.7	5.5
Torque constant	N·m/A <sub>(rms)</sub>	0.318	0.29	0.314	0.366	0.373	0.436	0.489
Heat time constant	min	5	7	10	12	15	18	20
Coil resistance	Ω	91.4	31.3	12.7	4.8	1.94	0.92	0.84
Coil inductance	mH	98.5	40.7	21.7	17.9	8.23	6.52	6.29
Induced voltage constant	V <sub>(rms)</sub> /min <sup>-1</sup>	0.0192	0.0175	0.019	0.0222	0.0226	0.0264	0.0296
Permissible thrust load	N	39.2	39.2	39.2	68.6	68.6	98	98
Permissible radial load	N	78.4	78.4	78.4	196	196	343	343
Mass	kg	0.3	0.4	0.5	0.9	1.3	2.2	2.5
Applicable servo amplifier	008P2	○	○	○	○			
	012P2					○		
	VL□□X-025P2						○	○

\* The maximum torque is obtained when the motor is used in combination with the standard BS series servo amplifier. (For any combination other than the standard one, consult with us.)

◆ The power supply unit for the brake is available from us.

◆ The values in the table above are obtainable when the armature coil temperature is 20℃

**Designed for CE-Marking**



IEC34-1/EN60034-1  
Standard relating to general motors  
(International standard/EU)

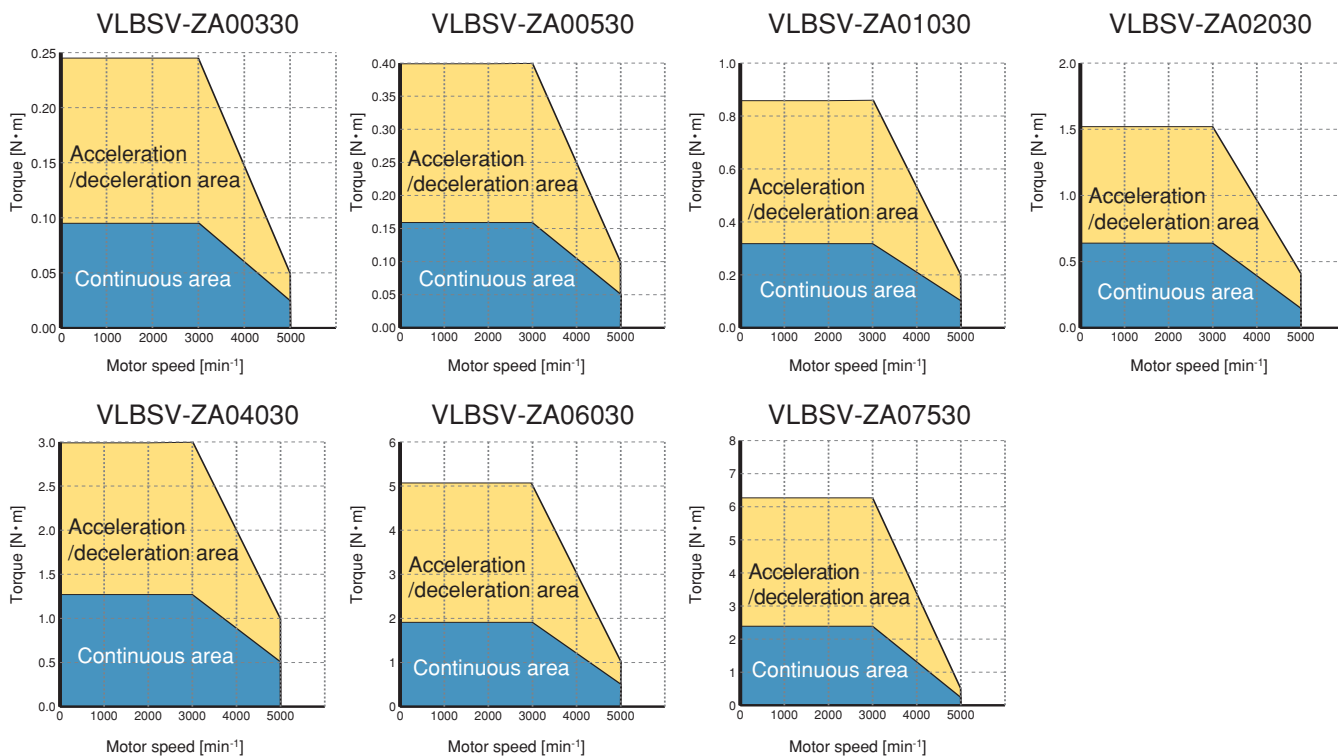

**B Brake (holding brake)**

The brake of the servo motor is a slim type dry non-excited electromagnetic brake. Use it for preventing the vertical shaft from falling and for holding the horizontal shaft at power OFF.

**K Straight shaft without key**

This shaft does not have any keyway and is the same as the standard shaft in diameter and length.

**G Reduction gear**

The small-capacity ZA type servo motor uses an Able reduction gear or HPG series reduction gear. For detailed specifications, consult with us.

**O Oil seal**

If oil of the output shaft will splash from the machine side, use of an oil seal is recommended.

V series motor model(ZA3000min<sup>-1</sup>)

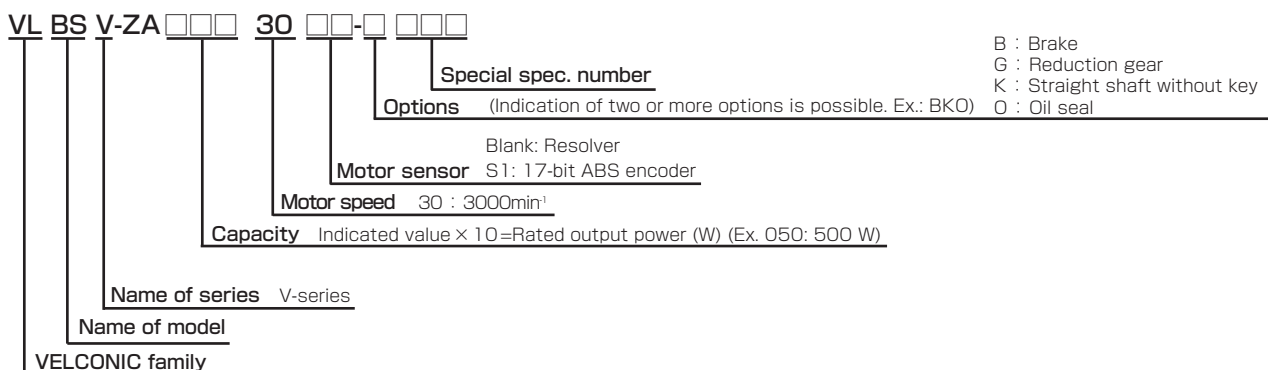

# V Series ZA Type 3000 min<sup>-1</sup>: Outer Dimensions (Resolver Specifications)

## VLBSV-ZA00330 • ZA00530 • ZA01030

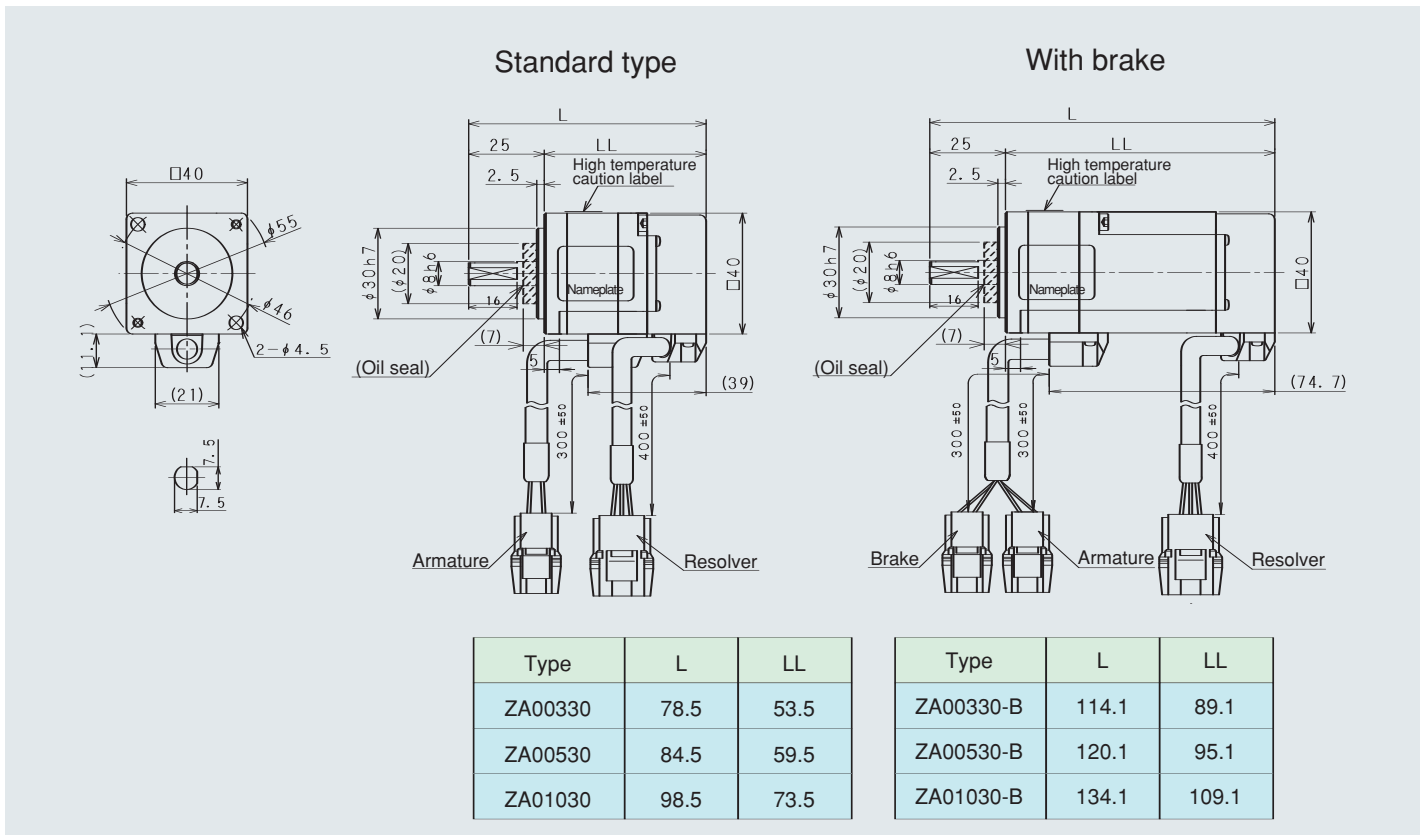

## VLBSV-ZA02030 • ZA04030

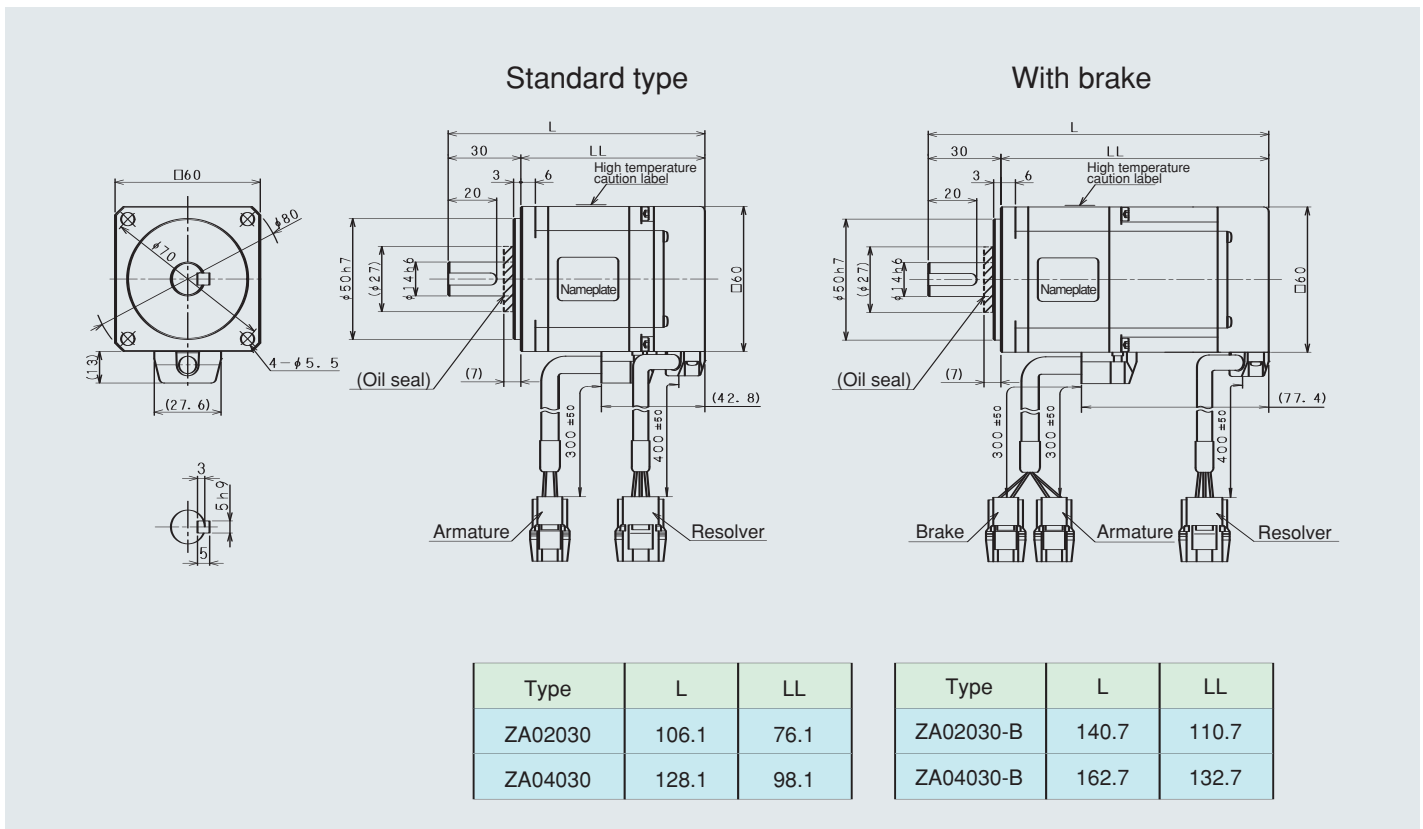

**VLBSV-ZA06030 • ZA07530**

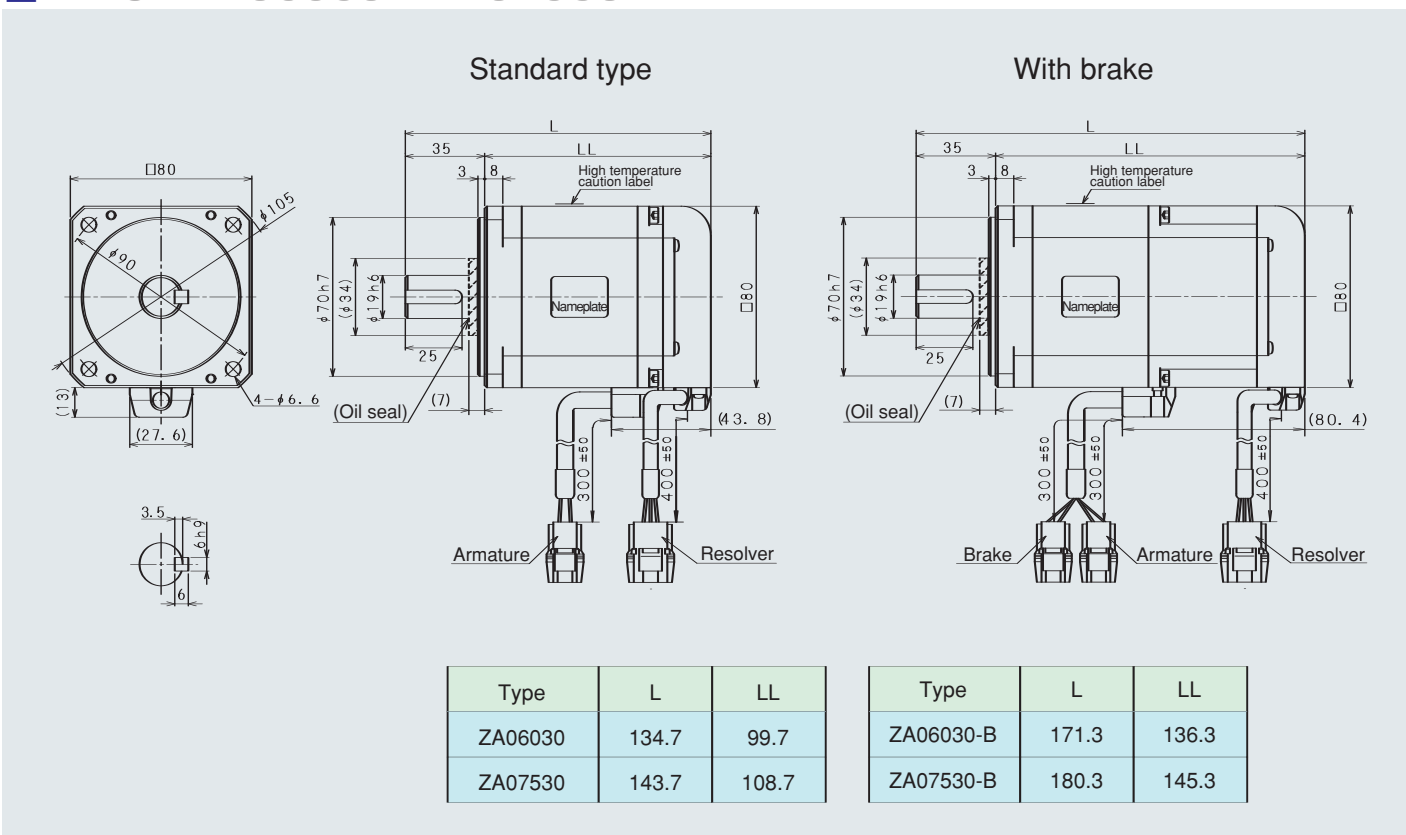

**Details of connector**

A cable attached with connector or connectors is available for an extra price.

Type of motor	Part name	Receptacle	Contact (pin)	Plug	Contact (socket)
Common to all types	Armature	YLR-04V	BYM-41T-P0.5A	YLP-04V	BYF-41T-P0.5A
Common to all types	Brake	YLR-02V	BYM-01T-P0.5A	YLP-02V	BYF-01T-P0.5A

**Brake performance table**

The rotor inertia and mass are the values of a single brake, excluding those of the motor.

Applicable motor	Static friction torque N·m	Rotor inertia $\times 10^{-4}$ kg·m <sup>2</sup>	Coil (20°C)				Suction time ms	Release time ms	Mass kg
			Voltage	Current	Resistance	Capacity			
			DC V	A	$\Omega$	W			
ZA00330	0.32	0.03	24	0.19	115	4	40	20	0.2
ZA00530									
ZA01030									
ZA02030	1.27	0.1	24	0.35	64	8	50	20	0.5
ZA04030									
ZA06030	2.39	0.24	24	0.33	73.5	8	60	30	0.9
ZA07530									

## V Series ZA Type 3000 min<sup>-1</sup>: Outer Dimensions (Encoder Specifications)

### VLBSV-ZA00330S1 • ZA00530S1 • ZA01030S1

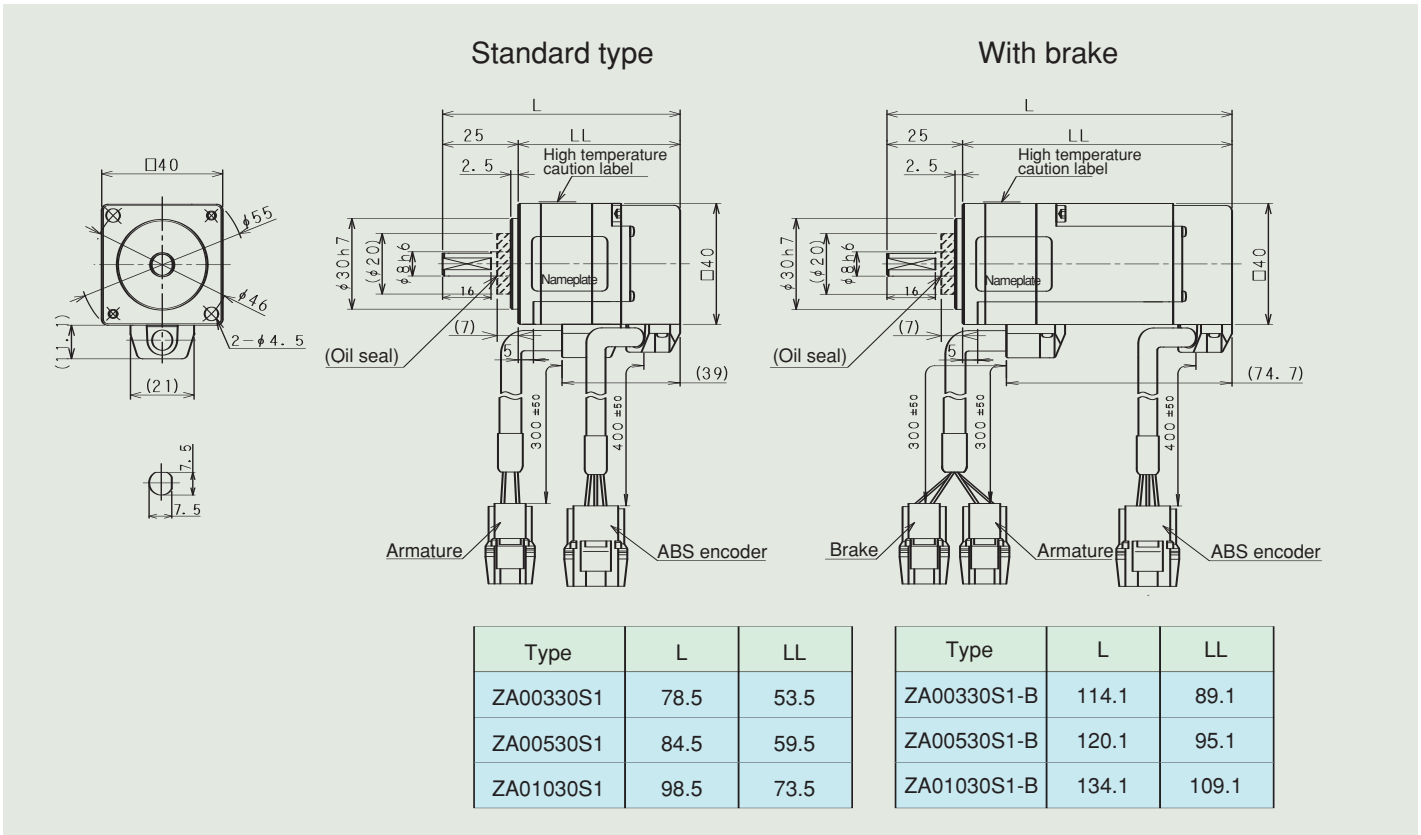

### VLBSV-ZA02030S1 • ZA04030S1

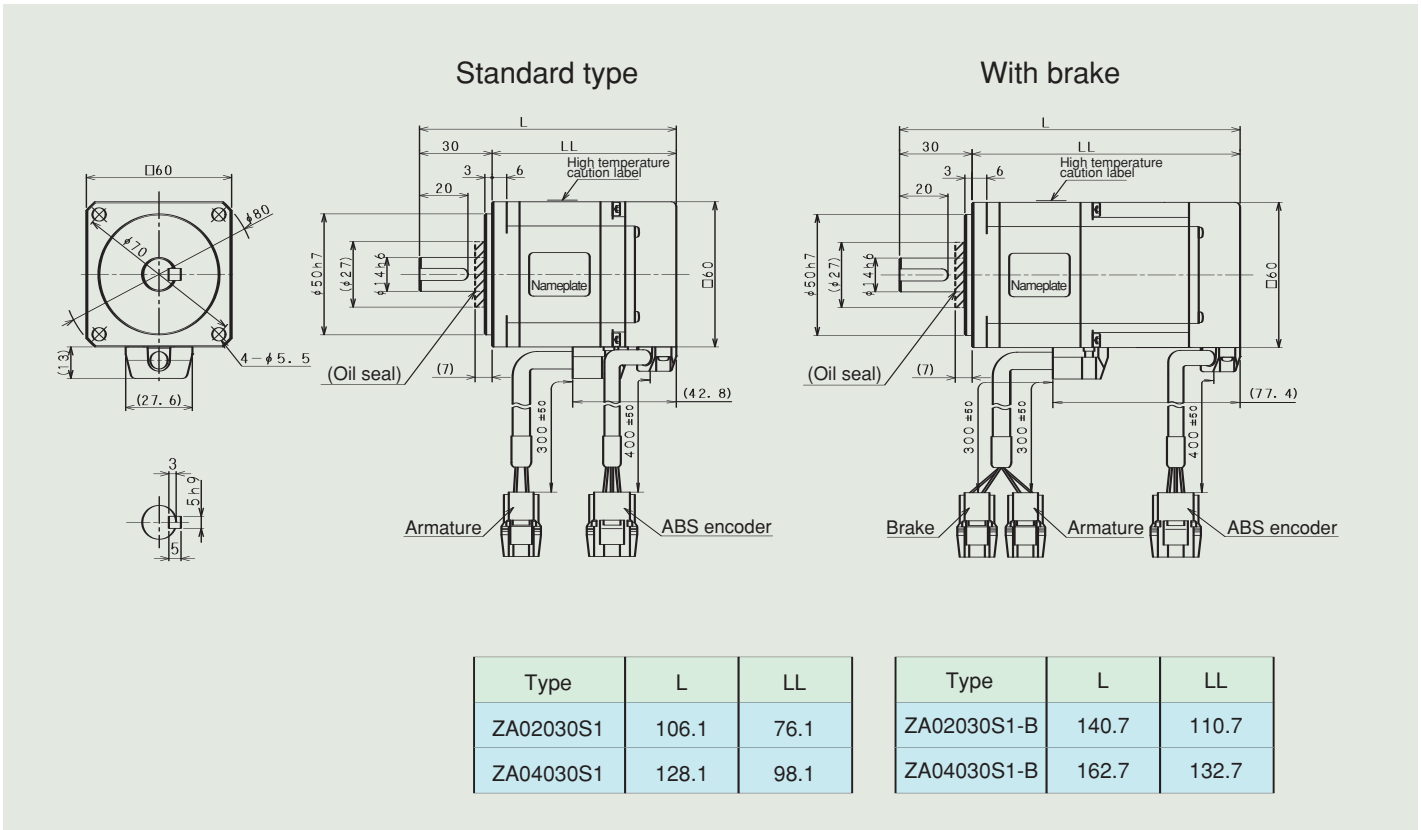

VLBSV-ZA06030S1 • ZA07530S1

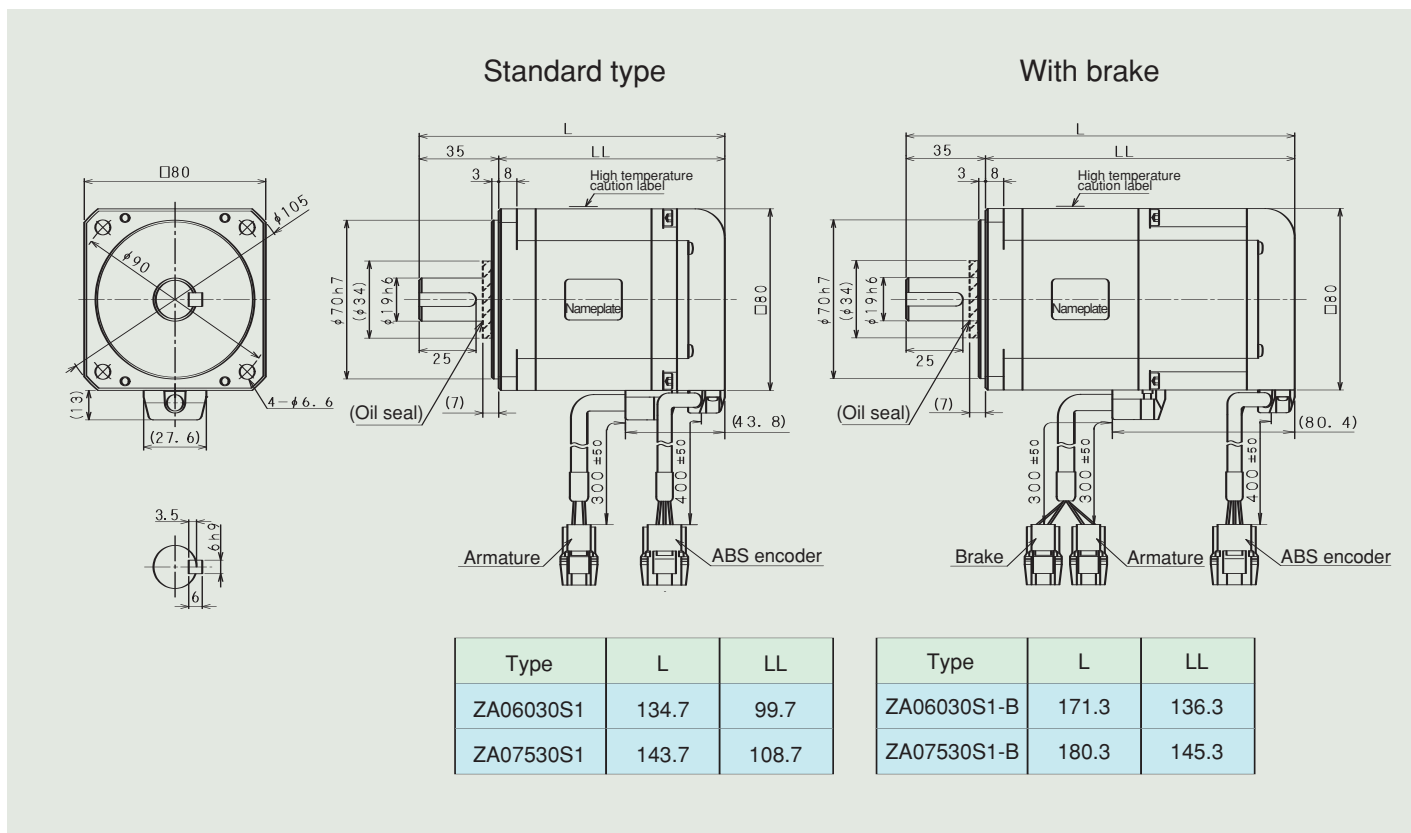

Details of connector

A cable attached with connector or connectors is available for an extra price.

Type of motor	Part name	Receptacle	Contact (pin)	Plug	Contact (socket)
Common to all types	Armature	YLR-04V	BYM-41T-P0.5A	YLP-04V	BYF-41T-P0.5A
Common to all types	Brake	YLR-02V	BYM-01T-P0.5A	YLP-02V	BYF-01T-P0.5A

Brake performance table

The rotor inertia and mass are the values of a single brake, excluding those of the motor.

Applicable motor	Static friction torque N·m	Rotor inertia $\times 10^{-4}$ kg·m <sup>2</sup>	Coil (20°C)				Suction time ms	Release time ms	Mass kg
			Voltage	Current	Resistance	Capacity			
			DC V	A	$\Omega$	W			
ZA00330S1	0.32	0.03	24	0.19	115	4	40	20	0.2
ZA00530S1									
ZA01030S1									
ZA02030S1	1.27	0.1	24	0.35	64	8	50	20	0.5
ZA04030S1									
ZA06030S1	2.39	0.24	24	0.33	73.5	8	60	30	0.9
ZA07530S1									

# V Series ZA Type 1500 min<sup>-1</sup>: Characteristics (Large-Sized)

- ◆ Time rating: Continuous
- ◆ Class of insulation: F
- ◆ Ambient temperature: 0 ~ +40°C
- ◆ Class of vibration: V15
- ◆ Method of excitation: Permanent magnet
- ◆ Method of protection: Totally-enclosed foam-proof (excluding shaft through area and connector) IP65
- ◆ Mounting method: Flange mounted type

Model		VLBSV-	
		ZA11K15	ZA14K15
Rated output	W	11000	14000
Rated torque	N · m	70	89.1
Rated speed	min <sup>-1</sup>	1500	1500
Max. speed	min <sup>-1</sup>	2000	1800
Power rate	kW/s	297	342
Moment of inertia	X10 <sup>-4</sup> kg·m <sup>2</sup>	215	311
Momentary max. torque	N · m	165	235
Momentary max. current	A <sub>(rms)</sub>	134	157
Rated voltage	V <sub>(rms)</sub>	129	148
Rated current	A <sub>(rms)</sub>	54.2	60.0
Torque constant	N · m/A <sub>(rms)</sub>	1.30	1.51
Heat time constant	min	30	40
Coil resistance	Ω	0.05	0.04
Coil inductance	mH	1.42	1.3
Induced voltage constant	V <sub>(rms)</sub> /min <sup>-1</sup>	0.08	0.0935
Permissible thrust load	N	392	392
Permissible radial load	N	784	784
Mass	kg	49	64
Applicable servo amplifier VL□□X-	200P3	○	
	320P3		○

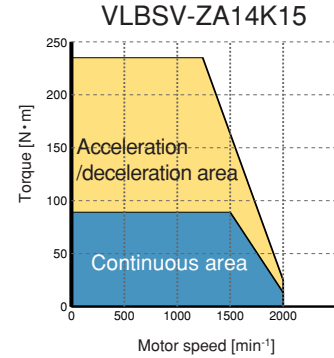
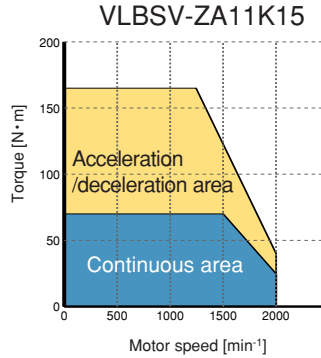

- \* The maximum torque is obtained when the motor is used in combination with the standard BS series servo amplifier. (For any combination other than the standard one, consult with us.)
- ◆ The power supply unit for the brake is available from us.
- ◆ The values in the table above are obtainable when the armature coil temperature is 20°C.

## **B** Brake (holding brake)

The brake of the servo motor is a slim type dry non-excited electromagnetic brake. Use it for preventing the vertical shaft from falling and for holding the horizontal shaft at power OFF.

## **K** Straight shaft without key

This shaft does not have any keyway and is the same as the standard shaft in diameter and length.

## **O** Oil seal

If oil of the output shaft will splash from the machine side, use of an oil seal is recommended.

## **G** Reduction gear

The mid-capacity ZA type servo motor uses a Coronet reduction gear. For detailed specifications, consult with us.

## **T** Taper shaft

The servo motor is standardly provided with straight shaft with key. A taper shaft is available optionally.

### V series motor model (ZA1500min<sup>-1</sup>)

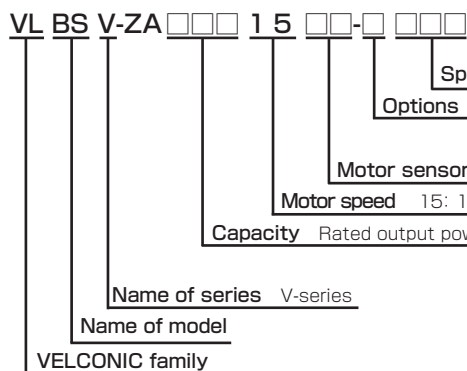

- B : Brake
- G : Reduction gear
- K : Straight shaft without key
- O : Oil seal
- T : Taper shaft

# Outer Dimensions

## VLBSV-ZA11K15 (S1) • VLBSV-ZA14K15 (S1)

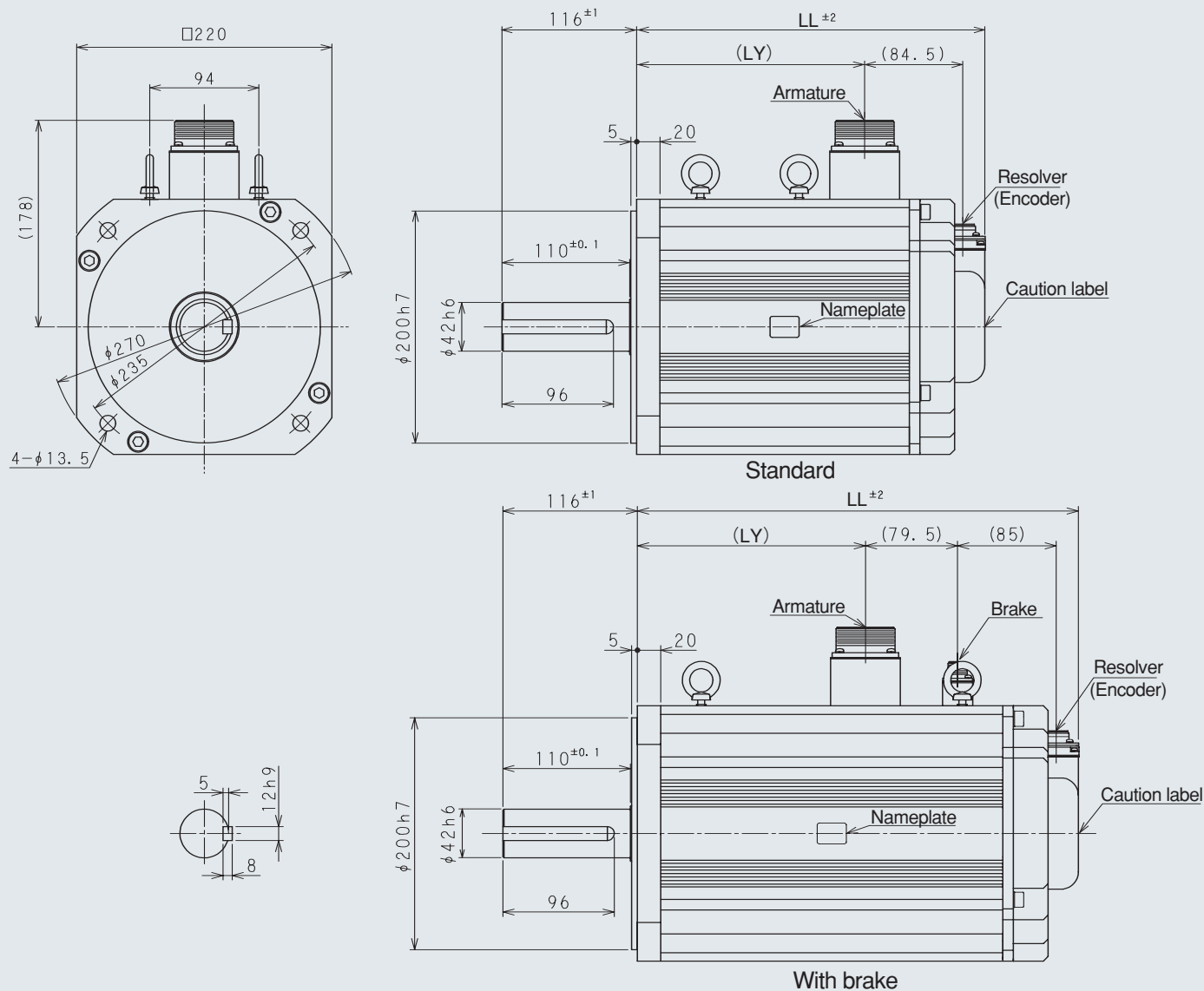

Type	LL	LY
ZA11K15	300	196.5
ZA14K15	360	256.5
ZA11K15-B	380	196.5
ZA14K15-B	440	256.5

### Plug selection table

Neither plug nor cable clamp is attached, which are available for extra prices.

Part name	Receptacle	Straight plug	Cable clamp
Armature	N/MS3102A32-17P	N/MS3106B32-17S	N/MS3057-20A
Brake	N/MS3102A10SL-4P	N/MS3106B10SL-4S	N/MS3057-4A

Use the standard motor resolver cable for the motor sensor cable.

(For further information on the model, etc., refer to Page 12 of the BS servo amplifier catalog.)

## G Series Standard Type 2000 min<sup>-1</sup>: Characteristics (Large-Sized)

- ◆ Time rating: Continuous    ◆ Class of insulation: F    ◆ Ambient temperature: 0~+40℃    ◆ Class of vibration: V15
- ◆ Method of excitation: Permanent magnet    ◆ Method of protection: Totally-enclosed foam-proof (excluding shaft through area) IP44    ◆ Mounting method: Flange mounted type

Item \ Model		VLBSG-		
		A20K20	A33K20	B55K20
Rated output	W	20000	33000	55000
Rated torque	N·m	95.5	157.5	263
Rated speed	min <sup>-1</sup>	2000	2000	2000
Max. speed	min <sup>-1</sup>	2200	2200	2200
Power rate	kW/s	222	191	364
Moment of inertia	X10 <sup>-4</sup> kg·m <sup>2</sup>	410	1300	1900
Momentary max. torque	N·m	186	320	526
Momentary max. current	A <sub>(rms)</sub>	212	353	276
Rated voltage	V <sub>(rms)</sub>	146	149	304
Rated current	A <sub>(rms)</sub>	96	157	120
Torque constant	N·m/A <sub>(rms)</sub>	1.0	1.0	2.3
Heat time constant	min	25	30	35
Coil resistance	Ω	0.032	0.0165	0.04
Coil inductance	mH	0.94	0.63	1.62
Induced voltage constant	V <sub>(rms)</sub> /min <sup>-1</sup>	0.064	0.064	0.142
Permissible thrust load	N	670	1800	1500
Permissible radial load	N	2700	4500	4800
Mass	kg	74	129	160
Applicable servo amplifier VL□□X-	320P3	○		
	500P3		○	
	400P4			○

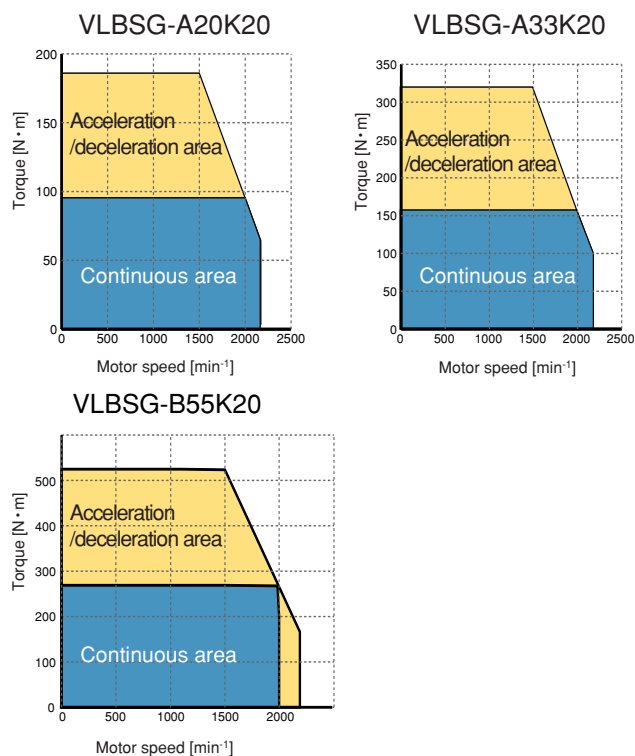

\* The maximum torque is obtained when the motor is used in combination with the standard BS series servo amplifier. (For any combination other than the standard one, consult with us.)

◆ For the brake specifications and brake power supply unit, contact us separately.

◆ The values in the table above are obtainable when the armature coil temperature is 20℃.

### **K** Straight shaft without key

This shaft does not have any keyway and is the same as the standard shaft in diameter and length.

### **O** Oil seal

If oil of the output shaft will splash from the machine side, use of an oil seal is recommended.

### G series motor model (2000min<sup>-1</sup>)

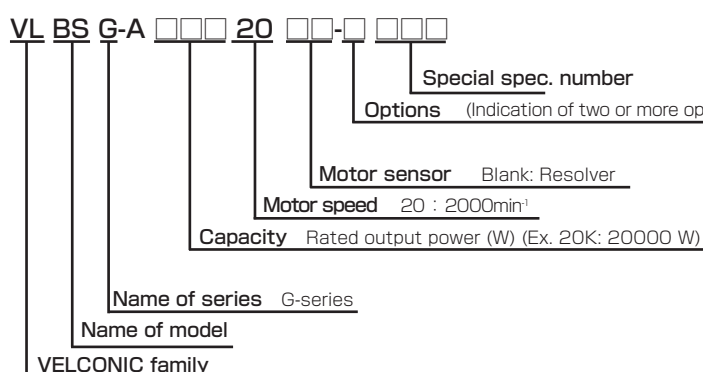

- K : Straight shaft without key
- O : Oil seal
- T : Taper shaft

# Outer Dimensions

## VLBSG-A20K20

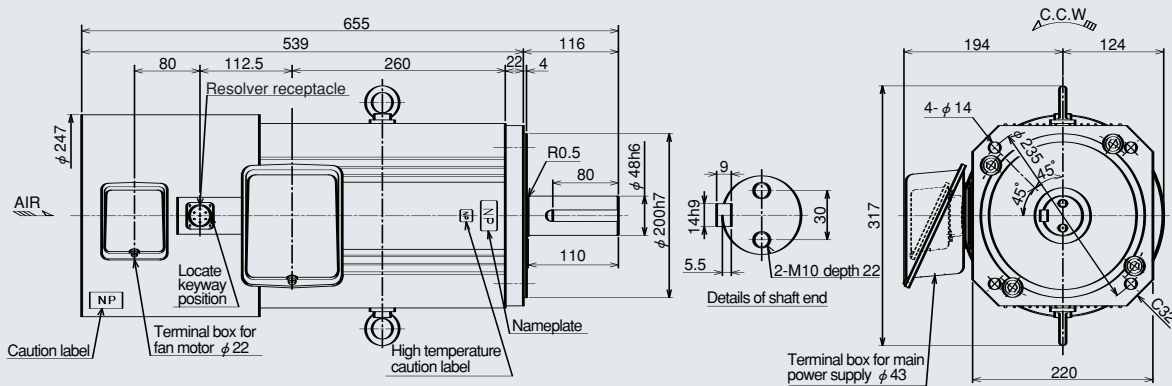

For the motor sensor cable, use the standard resolver cable. (For details, see the descriptions on "Selecting Cables" carried in this manual.)

## VLBSG-A33K20

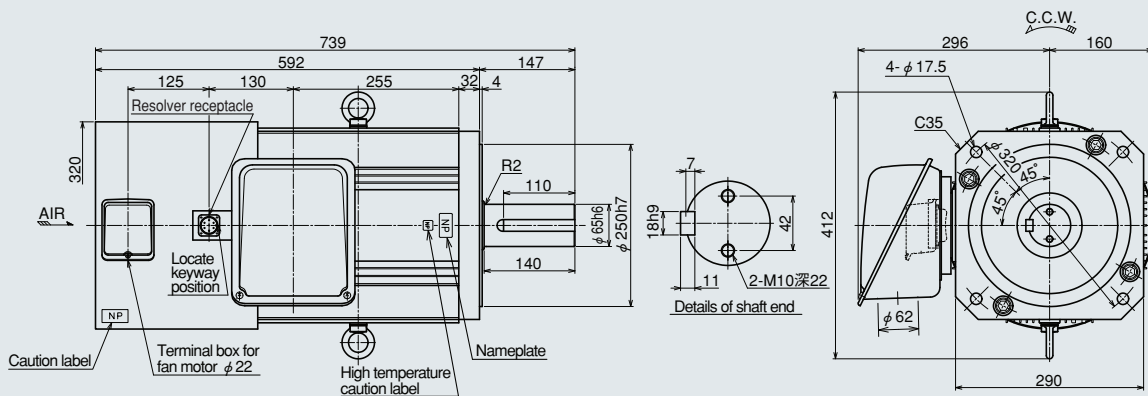

For the motor sensor cable, use the standard resolver cable. (For details, see the descriptions on "Selecting Cables" carried in this manual.)

## VLBSG-B55K20

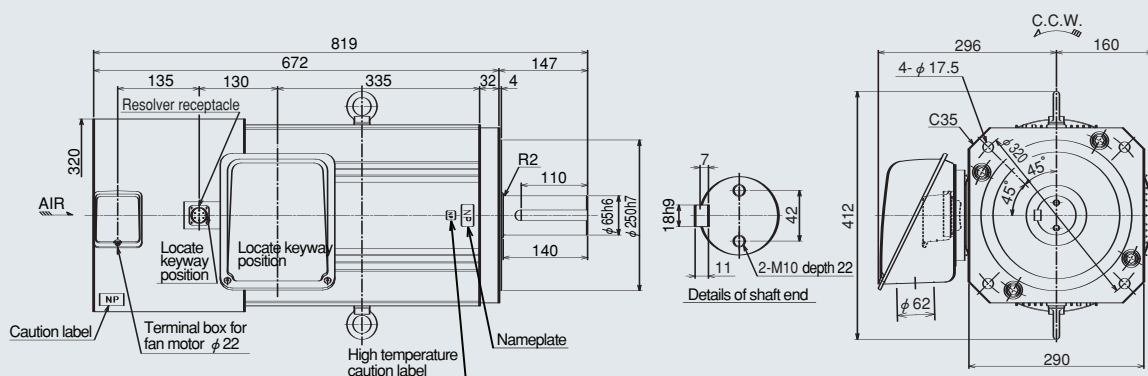

For the motor sensor cable, use the standard resolver cable. (For details, see the descriptions on "Selecting Cables" carried in this manual.)

## T Series Standard Type 1500/2000 min<sup>-1</sup>: Characteristics (Low Inertia)

- ◆ Time rating: Continuous    ◆ Class of insulation: F    ◆ Ambient temperature: -10~+40°C    ◆ Class of vibration: V15
- ◆ Method of excitation: Permanent magnet    ◆ Method of protection: Totally-enclosed foam-proof (excluding shaft through area) IP44    ◆ Mounting method: Flange mounted type

形式 Item		VLBST-□□□□□V								
		04015	08015	10015	15015	26015	37015	50015	75020	10K20
Rated output	W	400	800	1000	1500	2600	3700	5000	7500	10000
Rated torque	N·m	2.55	5.10	6.37	9.55	16.6	23.6	31.8	35.8	47.7
Rated speed	min <sup>-1</sup>	1500							2000	
Max. speed	min <sup>-1</sup>	2000							2500	
Power rate	kW/s	85	138	158	222	181	250	337	233	271
Moment of inertia	X10 <sup>-4</sup> kg·m <sup>2</sup>	0.76	1.89	2.57	4.10	15.2	22.3	30.0	55	84
Momentary max. torque	N·m	7.35	11	15.4	23	38	60	73	100	100
Momentary max. current	A(rms)	8.5	17.7	17.7	25	42	64	71	113	113
Rated voltage	V(rms)	108	118	128	122	133	121	127	139	124
Rated current	A(rms)	2.7	5.3	5.7	8.3	14.1	21	28	36	51
Torque constant	N·m/A(rms)	0.96	0.96	1.12	1.15	1.17	1.15	1.17	1.00	0.95
Heat time constant	min	15	17	22	26	30	42	53	55	60
Coil resistance	Ω	6.43	2.7	2.2	1.11	0.48	0.24	0.175	0.090	0.038
Coil inductance	mH	57	20	19	12.9	8.3	4.9	3.9	2.4	1.2
Induced voltage constant	V(rms)/min <sup>-1</sup>	0.058	0.059	0.069	0.070	0.074	0.071	0.071	0.061	0.057
Permissible thrust load	N	98	118	118	118	284	284	284	294	294
Permissible radial load	N	559	647	676	706	1350	1450	1520	1372	1470
Mass	kg	4.5	6.2	7.8	11	20	27	34	44	62
Applicable servo amplifier VL□□X-	012P2	○								
	025P2		○	○						
	035P3				○					
	070P3					○				
	100P3						○	○		
	200P3								○	○

\* The maximum torque is obtained when the motor is used in combination with the standard BS series servo amplifier. (For any combination other than the standard one, consult with us.)

◆ The power supply unit for the brake is available from us.

◆ The values in the table above are obtainable when the armature coil temperature is 20°C and the motor is used in combination with the standard BS series servo amplifier.

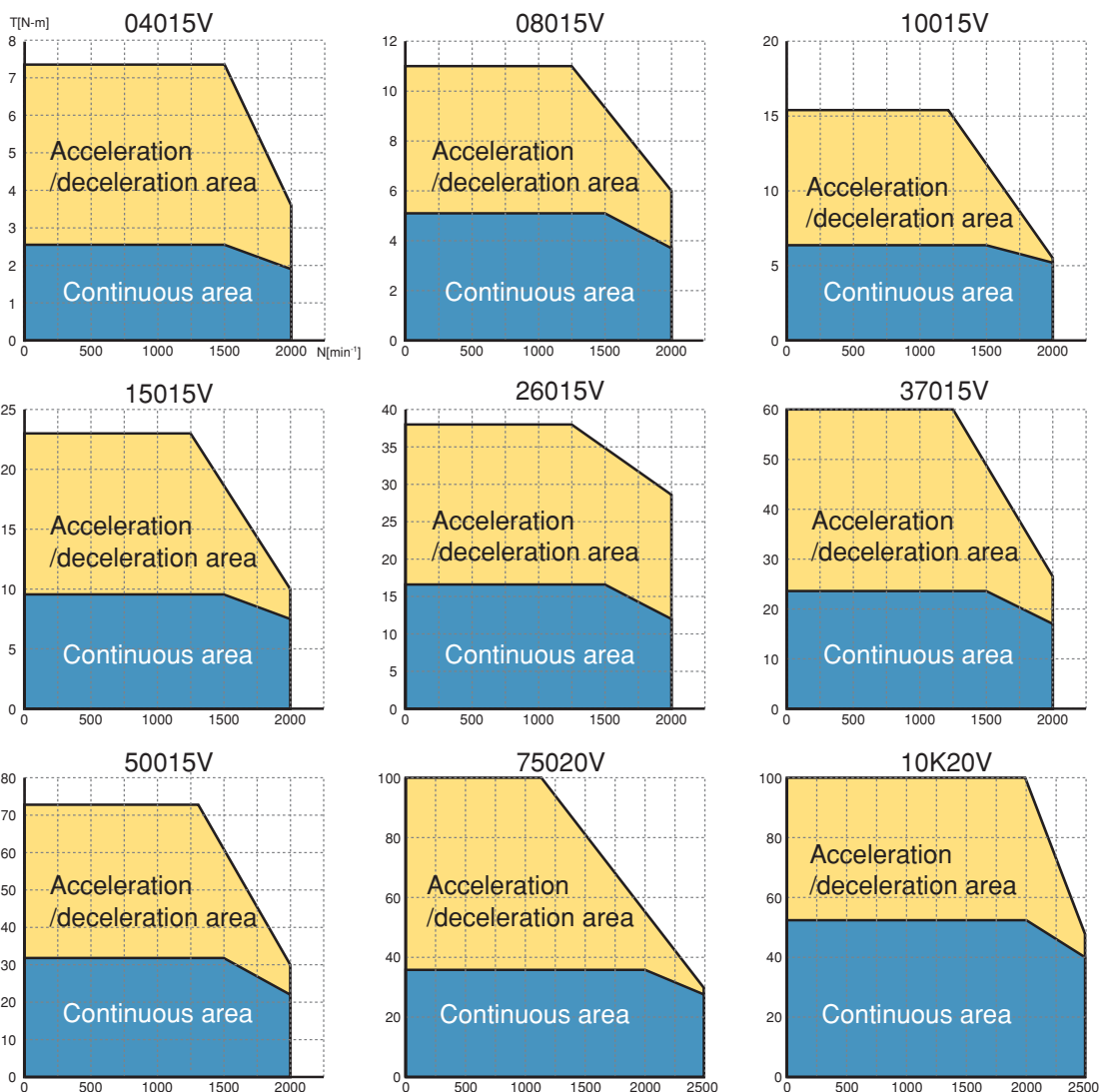

**VLBST-**      **V-**

Special spec. number

- B : Brake
  - C : Connector
  - G : Reduction gear
  - K : Straight shaft without key
  - O : Oil seal
  - T : Taper shaft
  - U : Designed for CE-Marking
- Options (Indication of two or more options is possible. Ex.: BKO)

Motor sensor V : 20 kHz resolver

Motor speed Indicated value × 100 = Rated speed (min<sup>-1</sup>) (Ex. 15: 1500 min<sup>-1</sup>)

Capacity Indicated value × 10 = Rated output power (W) (Ex. 370: 3700 W (3.7 kW))

# T Series Standard Type 1500/2000 min<sup>-1</sup>: Outer Dimensions

## VLBST-04015V

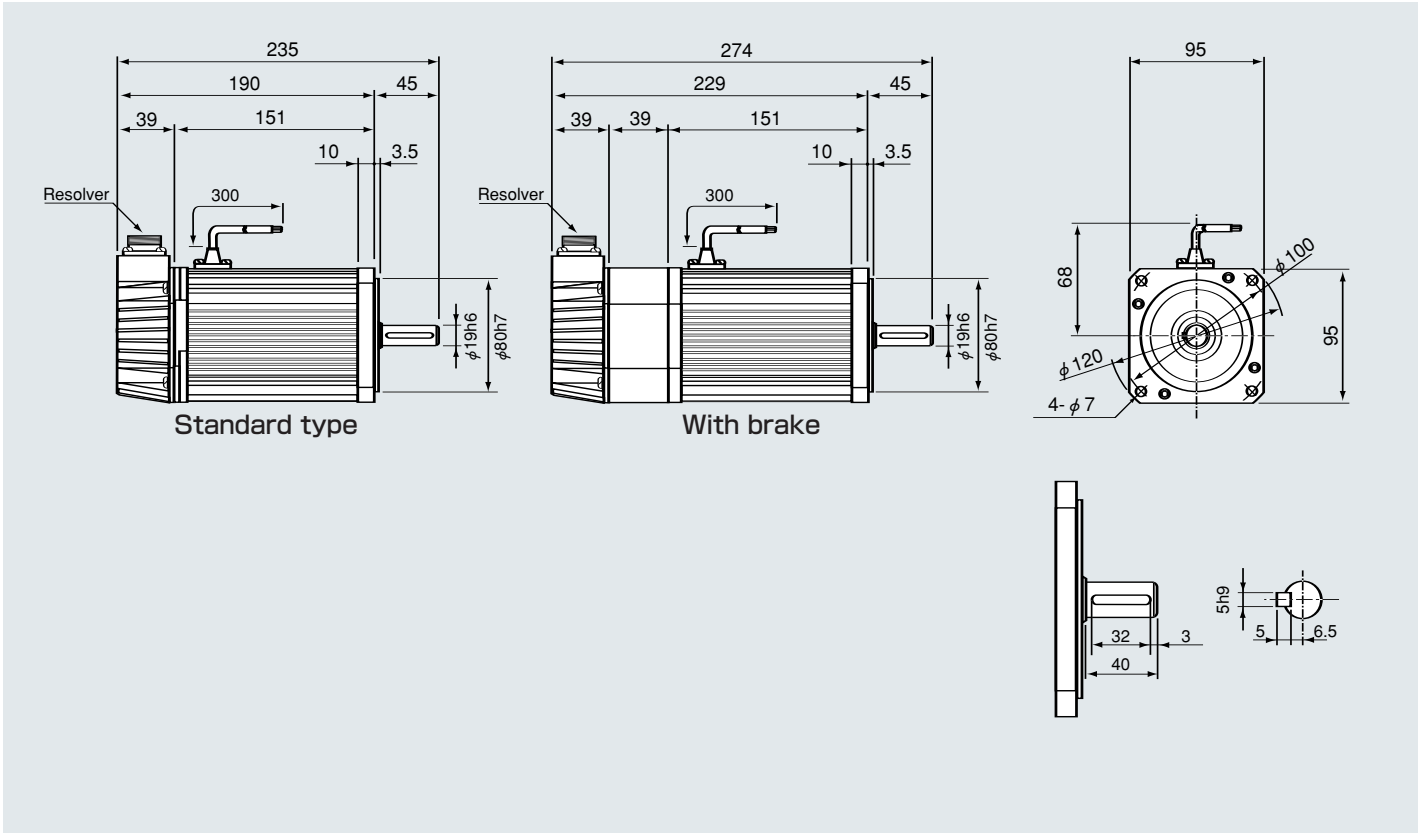

## VLBST-08015V • 10015V • 15015V

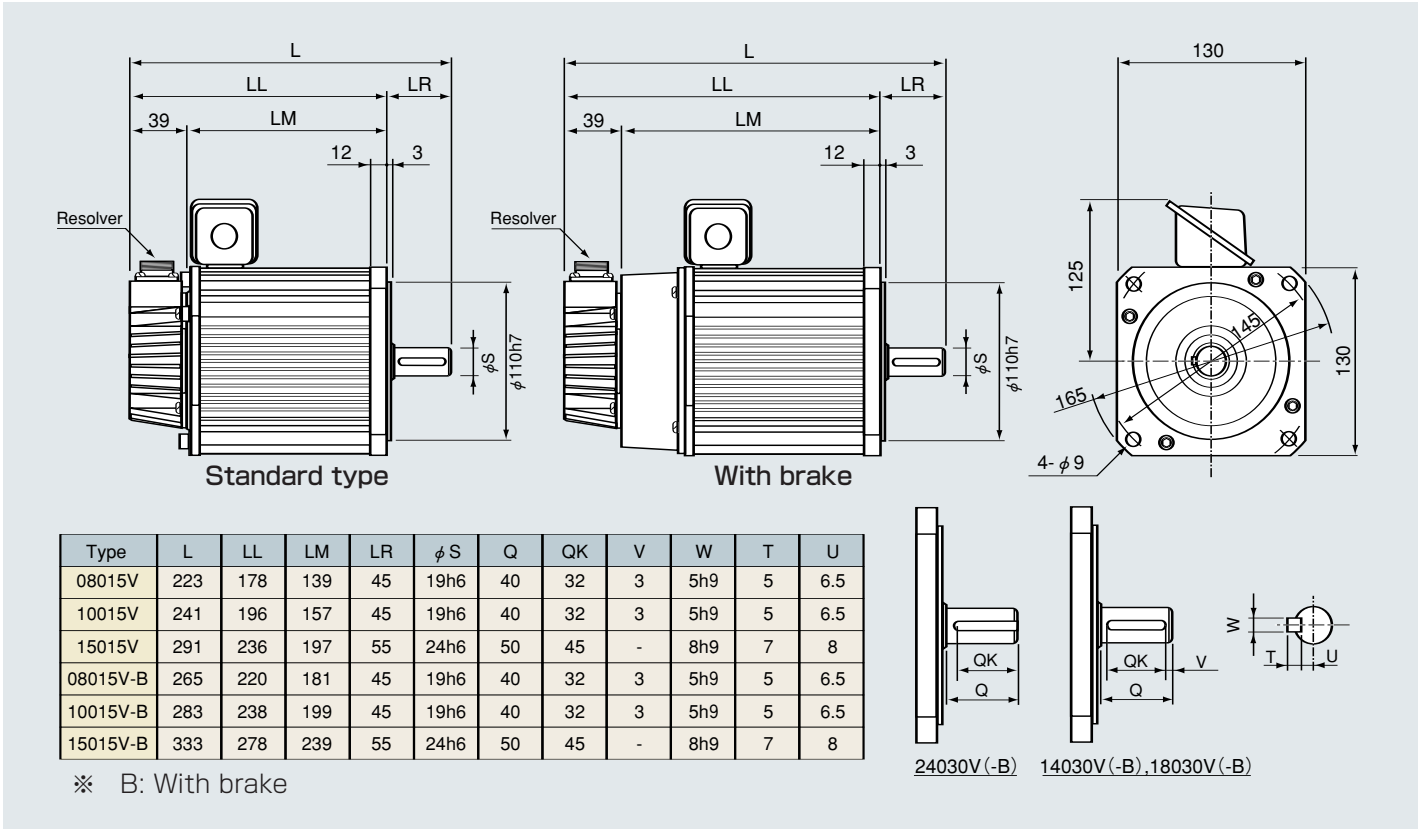

**VLBST-26015V • 37015V • 50015V**

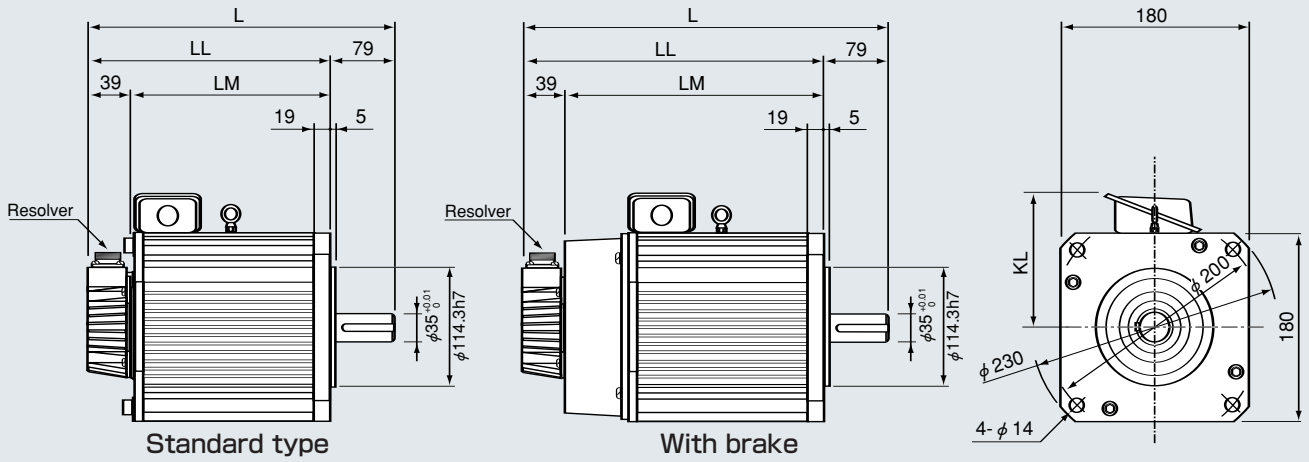

Type	L	LL	LM	KL	Hook bolt
26015V	317	238	199	145	Not provided
37015V	367	288	249	145	Provided
50015V	417	338	299	150	Provided
26015V-B	386	307	268	145	Not provided
37015V-B	436	357	318	145	Provided
50015V-B	486	407	368	150	Provided

※ B: With brake

**VLBST-75020V • 10K20V**

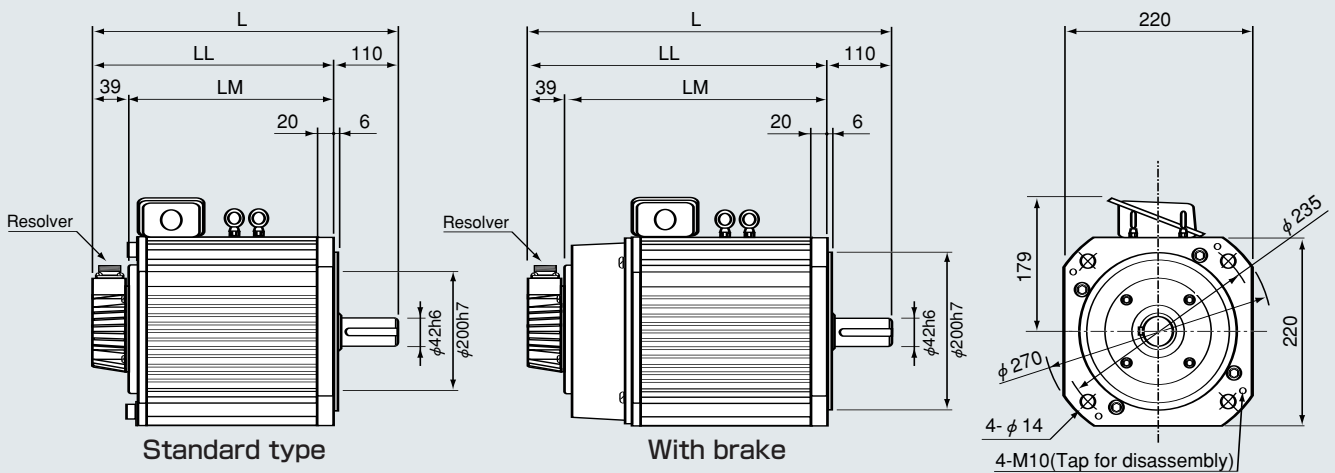

Type	L	LL	LM
75020V	424	314	275
10K20V	504	394	355
75020V-B	509	399	360
10K20V-B	589	479	440

※ B: With brake

## T Series Standard Type 3000 min<sup>-1</sup>: Characteristics (Low Inertia)

- ◆ Time rating: Continuous    ◆ Class of insulation: F    ◆ Ambient temperature: -10~+40°C    ◆ Class of vibration: V15  
 ◆ Method of excitation: Permanent magnet    ◆ Method of protection: Totally-enclosed foam-proof (excluding shaft through area) IP44    ◆ Mounting method: Flange mounted type

Model		VLBST-□□□□V								
		05030	08030	14030	18030	24030	65030	55030		65030
Rated output	W	500	800	1400	1800	2400	6500	5000	5500	6500
Rated torque	N·m	1.59	2.55	4.46	5.73	7.64	11.8	15.9	17.5	20.7
Rated speed	min <sup>-1</sup>	3000								
Max. speed	min <sup>-1</sup>	4000								
Power rate	kW/s	53	85	105	128	142	92	113	137	143
Moment of inertia	X10 <sup>-4</sup> kg·m <sup>2</sup>	0.47	0.76	1.89	2.57	4.1	15.2	22.3		30
Momentary max. torque	N·m	4.2	7.8	10	14	21	29.8	40	47	60
Momentary max. current	A(rms)	8.5	17.7	25	30	42	64	71	92	113
Rated voltage	V(rms)	117	100	124	116	109	113	112	115	115
Rated current	A(rms)	2.9	5.4	8.1	10.4	13.8	21	28	31	38
Torque constant	N·m/A(rms)	0.55	0.47	0.57	0.57	0.55	0.59	0.57		0.57
Heat time constant	min	10	15	17	23	30	30	36		48
Coil resistance	Ω	4.66	1.63	1.0	0.54	0.28	0.12	0.07		0.046
Coil inductance	mH	25	11.9	8.3	5.0	3.3	2.0	1.5		1.1
Induced voltage constant	V(rms)/min <sup>-1</sup>	0.033	0.028	0.035	0.035	0.035	0.036	0.035		0.035
Permissible thrust load	N	49	88	98	98	98	235	235		235
Permissible radial load	N	284	441	510	539	559	1068	1147		1205
Mass	kg	3.2	4.5	6.2	7.8	11	20	27		34
Applicable servo amplifier	012P2	○								
	025P2		○							
	035P3			○						
	070P3				○	○				
VL□□X-	100P3						○	○		
	200P3								○	○

\* The maximum torque is obtained when the motor is used in combination with the standard BS series servo amplifier. (For any combination other than the standard one, consult with us.)

◆ For the brake power supply, contact us separately.

◆ The values in the table above are obtainable when the armature coil temperature is 20°C and the motor is used in combination with the standard BS series servo amplifier.

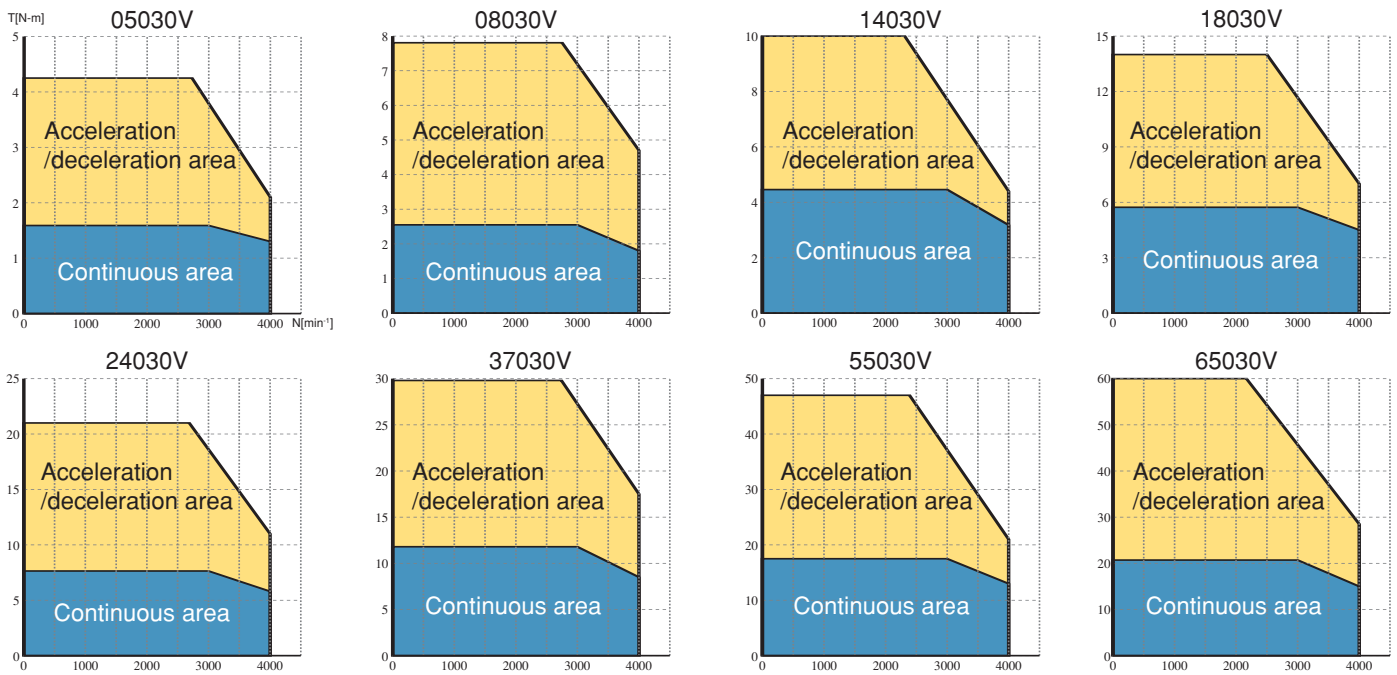

**VLBST-**     **V-**

Special spec. number

- B : Brake
- C : Connector
- G : Reduction gear
- K : Straight shaft without key
- O : Oil seal
- T : Taper shaft
- U : Designed for CE-Marking

Options (Indication of two or more options is possible. Ex.: BKO)

Motor sensor V : 20 kHz resolver

Motor speed Indicated value × 100 = Rated speed (min<sup>-1</sup>) (Ex. 30: 3000 min<sup>-1</sup>)

Capacity Indicated value × 10 = Rated output power(W) Ex: 370: 3700W(3.7 kW)

# T Series Standard Type 3000 min<sup>-1</sup>: Outer Dimensions

## VLBST-05030V • 08030V

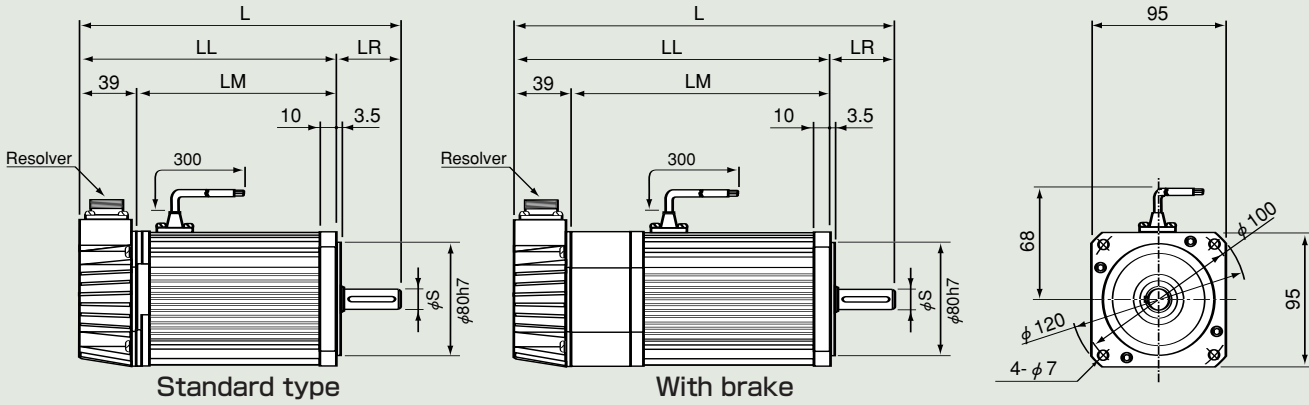

Type	L	LL	LM	LR	φ S	Q	QK	V	U
05030V	193	158	119	35	14h6	30	25	2	4
08030V	235	190	151	45	19h6	40	32	3	6.5
05030V-B	232	197	158	35	14h6	30	25	2	4
08030V-B	274	229	190	45	19h6	40	32	3	6.5

※ B: With brake

## VLBST-14030V • 18030V • 24030V

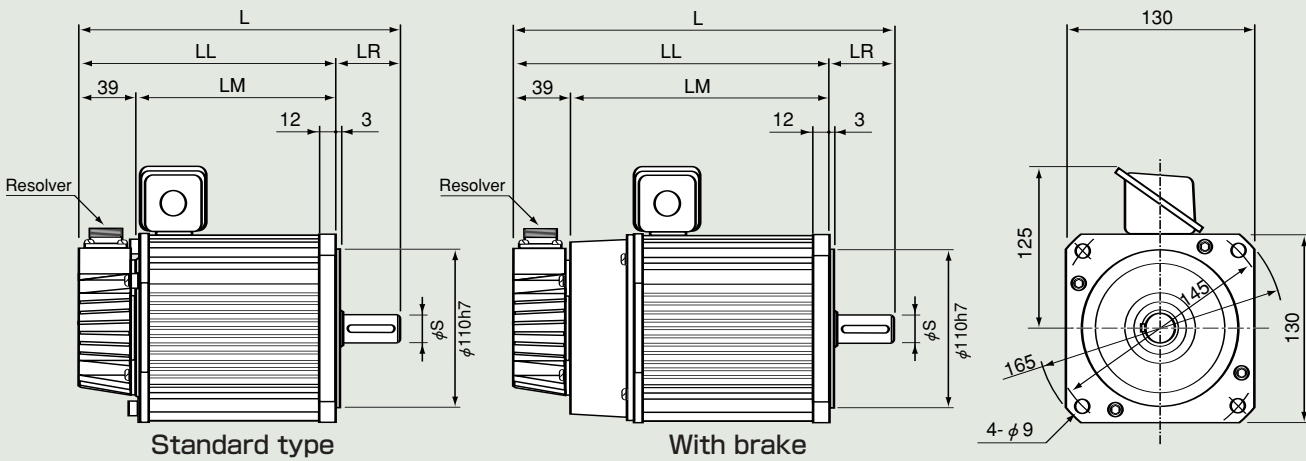

Type	L	LL	LM	LR	φ S	Q	QK	V	W	T	U
14030V	223	178	139	45	19h6	40	32	3	5h9	5	6.5
18030V	241	196	157	45	19h6	40	32	3	5h9	5	6.5
24030V	291	236	197	55	24h6	50	45	-	8h9	7	8
14030V-B	265	220	181	45	19h6	40	32	3	5h9	5	6.5
18030V-B	283	238	199	45	19h6	40	32	3	5h9	5	6.5
24030V-B	333	278	239	55	24h6	50	45	-	8h9	7	8

※ B: With brake

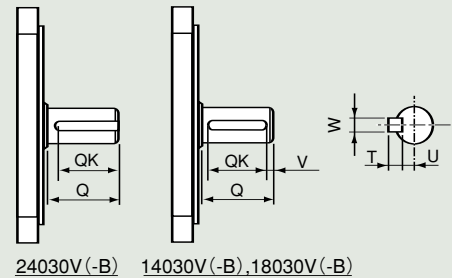

VLBST-37030V • 55030V • 65030V

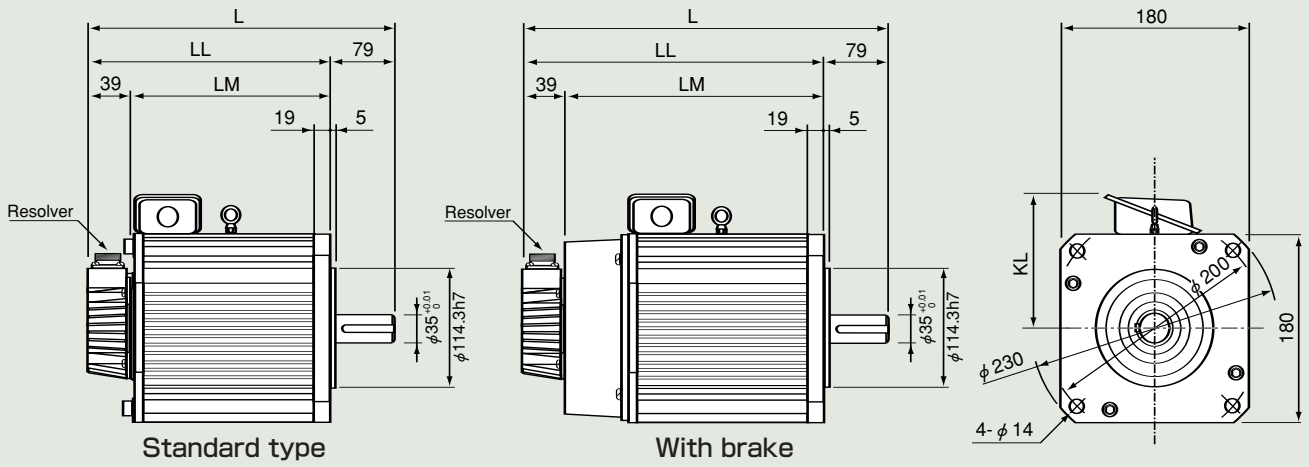

Type	L	LL	LM	KL	Hook bolt
37030V	317	238	199	145	Not provided
55030V	367	288	249	150	Provided
65030V	417	338	299	150	Provided
37030V-B	386	307	268	145	Not provided
55030V-B	436	357	318	150	Provided
65030V-B	486	407	368	150	Provided

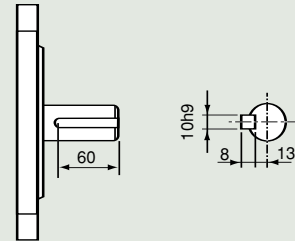

※ B: With brake

## T series Standard Type: Options

### **B** Brake (holding brake)

The brake of the servo motor is a slim type dry non-excited electromagnetic brake. Use it for preventing the vertical shaft from falling and for holding the horizontal shaft at power OFF.

### **C** Connector

For the T-series mid-capacity motor, the terminal box is replaced by connector.  
For the small-capacity motor, a relay connector is attached to the lead wire.

### **G** Reduction gear

A variety of reduction gears are available to utilize the full characteristics of the T-series servo motor.  
For the small-capacity motor, an Able reduction gear or HPG series reduction gear is employed. For the motor of mid-capacity or more, a Coronet reduction gear is used. For detailed specifications, consult with us.

### **K** Straight shaft without key

This shaft does not have any keyway and is the same as the standard shaft in diameter and length.

### **O** Oil seal

If oil of the output shaft will splash from the machine side, use of an oil seal is recommended.

### **T** Taper shaft

The T series servo motor is standardly provided with straight shaft with key. A taper shaft is available optionally.

### **U** Designed for CE-Marking



IEC34-1/EN60034-1  
Standard relating to general motors  
(International standard/EU)

Brake specifications

Applicable motor		Static friction torque N·m	Rotor inertia ×10 <sup>-4</sup> kg·m <sup>2</sup>	Coil (20°C)				Suction time ms	Release time ms	Mass kg
				Voltage	Current	Resistance	Capacity			
				DC V	A	Ω	W			
04015V	05030V	1.96	0.185	24	0.41	59	10	35	12	0.8
	08030V									
08015V	14030V	7.84	0.675	24	0.63	38	15	55	15	2
10015V	18030V									
15015V	24030V									
26015V	37030V	29.4	3.0	24	0.96	25	23	100	35	4
37015V	55030V									
50015V	65030V									
75020V		98	13	24	1.37	17.5	33	180	65	11
10K20V										

## Correspondence table of options

Each option is set for each type of the T-series motors.  
For the special specifications, consult with us.

● : Can be supported. ▲ : Consult with us.

Type	Type of motor	B	C	G	K	O	T	U
T-series standard 1500/2000	04015V	●	●	▲	●	●	●	●
	08015V	●	●	▲	●	●	●	●
	10015V	●	●	▲	●	●	●	●
	15015V	●	●	▲	●	●	●	●
	26015V	●	●	▲	●	●	●	●
	37015V	●	●	▲	●	●	●	●
	50015V	●	▲	▲	●	●	●	●
	75020V	●	▲	▲	●	●	●	●
	10K20V	●	▲	▲	●	●	●	●
T-series standard 3000	05030V	●	●	▲	●	●	●	●
	08030V	●	●	▲	●	●	●	●
	14030V	●	●	▲	●	●	●	●
	18030V	●	●	▲	●	●	●	●
	24030V	●	●	▲	●	●	●	●
	37030V	●	●	▲	●	●	●	●
	55030V	●	●	▲	●	●	●	●
	65030V	●	▲	▲	●	●	●	●

Note: The armature, brake and motor sensor cables are 300 mm-long and the connector is not water-proof.

## Details of armature exclusive connector

Wiring of the T-series motor armature is standardly performed, using the terminal box. To use the connector, you have to select the optional connector specifications (-C) or CE-Marking specifications (-U). The type of connector differs with each option, as tabled below. The CE-Marking specifications are pursuant to IP54 with an oil seal attached to the shaft.

1500min <sup>-1</sup>	2000min <sup>-1</sup>	3000min <sup>-1</sup>	Option	Receptacle	Straight plug	Cable clamp
VLBST-04015V	-	05030V	C	N/MS3102A16S-1P	N/MS3106B16S-1S	N/MS3057-8A
		08030V	U	JL04V-2E18-12PE-B-R	JL04V-6A18-12SE-EB-R	JL04-18CK(13)-R
VLBST-08015V VLBST-10015V VLBST-15015V	-	14030V	C	JA3102A20-15PC-F0-R	N/MS3106B20-15S	N/MS3057-12A
		18030V	U	JL04V-2E20-15PE-B-R	JL04V-6A20-15SE-EB-R	JL04-2022CK(14)-R
		24030V				
VLBST-26015V VLBST-37015V	-	37030V	C	N/MS3102A24-10P	N/MS3106B24-10S	N/MS3057-16A
			U	JL04V-2E24-10PE-B-R	JL04V-6A24-10SE-EB-R	JL04-2428CK(17)-R
VLBST-50015V	75020V 10K20V	55030V 65030V	C	For this type, consult with us.		
			U	JL04V-2E32-17PE-B-R	※ Plug block JL04V-6A32-17SE-R	
				Connector exclusively used for brake		
			U	JL04V-2E10SL-3PE-B-R	JL04V-6A10SL-3SE-EB-R	JL04-1012CK(05)-R

※To select the plug block, a conduit should be incorporated.

# TOSHIBA MACHINE CO., LTD.

## CONTROL EQUIPMENT SALES GROUP

Headquarters 2068-3, Ooka, Numazu-shi, Shizuoka-ken, 410-8510, JAPAN  
TEL: 81-(0)55-926-5141 FAX: 81-(0)55-925-6501

Homepage Address <http://www.toshiba-machine.co.jp>



### Cautions on safety

- Before using, read through and completely understand the appropriate instruction manual provided separately.
- The contents carried in this catalog may be subject to change without prior notice to effect improvements.

### Export of the products listed on this catalog

1. The final user or final application of these products may be subject to export restriction as defined by the Foreign Exchange and Foreign Trade Control Law of Japan. If they are to be exported, they shall undergo full screening and pass the required export procedures.
2. When these products are incorporated in another equipment, the customer may be required to apply for the export permission, depending on the application of the another equipment.

- Tokyo Sales Section 2-2, Uchisaiwaicho 2-chome, Chiyoda-ku, Tokyo 100-8503  
Phone: 81-3-3509-0270  
Fax: 81-3-3509-0335
- Export Sales Section 2068-3, Ooka, Numazu-shi, Shizuoka-ken, 410-8510  
Phone: 81-55-926-5032  
Fax: 81-55-925-6527
- Osaka Sales Office 1-12-39 Sin-Hankyu Build., Umeda, Kita-ku, Osaka-shi, Osaka 530-0001  
Phone: 81-6-6341-6181  
Fax: 81-6-6341-2738
- Nagoya Sales Office 5-307, kamiyashiro, Meito-ku, Nagoya-shi, Aichi-ken 465-0025  
Phone: 81-52-702-7660  
Fax: 81-52-702-1141

### Service Division

#### TOEI ELECTRIC CO., LTD.

131 Matsumoto, Mishima-shi, Shizuoka Pref. 411-8510  
Phone: 81-55-977-0129  
Fax: 81-55-977-3744