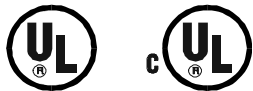


Q7 *Flow* Adjustable Speed Drive Installation and Operation Manual

[Toshiba inverter Q7 speed drive user manual](#)

Document Number: 54963-002

Date: December, 2004



About This Manual

This manual was written by the Toshiba Technical Publications Group. This group is tasked with providing technical documentation for the **Q7 Flow** system. This manual provides information that will assist the qualified installer, operator, or maintenance personnel in the safe installation and operation of the **Q7 Flow**. This manual is intended to be used in conjunction with the **Q7 ASD Installation and Operation Manual** (P/N 57246).

This manual provides information on the various features that pertain to the installation and operation of this powerful cost-saving device and is applicable to the **Q7 Flow** only.

Every effort has been made to provide accurate and concise information to you, our customer.

TOSHIBA is a registered trademark of the Toshiba Corporation.

Reliability in motion is a trademark of the Toshiba Corporation.

All other product or trade references appearing in this manual are registered trademarks of their respective owners.

The information in this manual is subject to change without notice.

Toshiba International Corporation (TIC) shall not be liable for technical or editorial omissions or mistakes in this manual, nor shall it be liable for incidental or consequential damages resulting from the use of information contained in this manual.

This manual is copyrighted. No part of this manual may be photocopied or reproduced in any form without the prior written consent of Toshiba International Corporation.

Email your comments, questions, or concerns about this publication to
Jay.Williams@TIC.TOSHIBA.COM.

Contacting Toshiba's Customer Support Center

Toshiba's helpful Customer Support Center can be contacted to obtain assistance in resolving any **Q7 Flow** system problem that you may experience or to provide application information.

The center is open from 8 a.m. to 5 p.m. (CST), Monday through Friday. The Support Center's toll free number is US (800) 231-1412/Fax (713) 466-8773 — Canada (800) 527-1204.

You may also contact Toshiba by writing to:

Toshiba International Corporation
13131 West Little York Road
Houston, Texas 77041-9990
Attn: ASD Product Manager.

For further information on Toshiba's products and services, please visit our website at **TIC.TOSHIBA.COM.**

© Copyright 2004 Toshiba International Corporation.

All rights reserved.

Printed in the U.S.A.

Introduction

Congratulations on the purchase of the new **Q7 Flow Adjustable Speed Drive (ASD)**. The **Q7 Flow** is a solid-state AC drive. The **Q7 Flow** is ideally suited to drive the variable torque load in your HVAC system. Toshiba's technology, quality, and reliability enables the motor to develop good torque and provide compensation for motor slip, which results in smooth, quick starts and highly efficient operation. The **Q7 Flow** uses digitally-controlled pulse width modulation. The programmable functions may be accessed via the easy-to-use menu. These features, combined with Toshiba's high-performance software, delivers unparalleled motor control and reliability.

The **Q7 Flow** is a very powerful tool, yet surprisingly simple to operate. The **Q7 Flow** has an easy-to-read LCD screen that provides easy access to the many monitoring and programming features of the **Q7 Flow**.

The motor control software is menu-driven, which allows for easy access to the motor control parameters and quick changes when required.

The **Q7 Flow** and the **Q7 ASD** systems perform all of the ASD functions that Toshiba has become known for including the ability to run at 110% for up to 60 seconds. Both systems have the added advantage of being offered at a significantly reduced cost when compared to comparably sized ASD systems.

To maximize the abilities of your new **Q7 Flow**, a working familiarity with this manual will be required. This manual has been prepared for the **Q7 Flow** installer, operator, and maintenance personnel.

Whether you are using the **Q7 ASD Power Unit** or the **Q7 Flow**, both are truly **Reliability in motion**.

Important Notice

This manual may not cover all of the variations of ASD applications, nor may it provide information on every possible contingency concerning installation.

The contents of this manual shall not become a part of or modify any prior agreement, commitment, or relationship between the customer and Toshiba International Corporation. The sales contract contains the entire obligation of Toshiba International Corporation. The warranty contained in the contract between the parties is the sole warranty of Toshiba International Corporation's ASD Division and any statements contained herein do not create new warranties or modify the existing warranty.

Any electrical or mechanical modifications to this equipment without prior written consent of Toshiba International Corporation will void all warranties and may void the UL/CUL listing or other safety certifications. Unauthorized modifications may also result in equipment damage or personal injury.

TOSHIBA INTERNATIONAL CORPORATION

Q7 Flow Adjustable Speed Drive

Please complete the Warranty Card supplied with the ASD and return it to Toshiba by prepaid mail. This will activate the 12 month warranty from the date of installation; but, shall not exceed 18 months from the date of purchase.

Complete the following information about the drive and retain it for your records.

Q7 Flow Model Number: _____

Q7 Flow Serial Number: _____

Project Number (if applicable): _____

Inspected By: _____

Name of Application: _____

Date of Installation: _____

Table of Contents

General Safety Information	1
Special Symbols	2
Equipment Warning Labels	2
Qualified Personnel	3
Equipment Inspection	3
Handling and Storage	3
Disposal	4
Installation Precautions	4
System Integration Precautions	6
System Setup Requirements	7
Operational and Maintenance Precautions	8
CE Compliance Requirements	9
Using RCD Protection	9
EMC Installation Guidelines	9
Q7 Flow Installation	11
Installation Notes	11
Q7 Flow Mounting and Connections	12
I/O and Control	15
Q7 Flow Monitoring/Control Interface	19
Typical Q7 Flow Connection Diagram	20
System Protection	25
ASD Protection	25
Motor Protection	27
Q7 Flow Control Panel Features	30
Q7 Flow Theory of Operation	32
Enclosure Dimensional Information and Weights	34
Enclosure Dimensions/Weights	35
Cable/Terminal Specifications	38
Current/Voltage Specifications	40

General Safety Information

DO NOT attempt to install, operate, maintain or dispose of this equipment until you have read and understood all of the product safety information and directions that are contained in this manual.

Safety Alert Symbol

The **Safety Alert Symbol** indicates that a potential personal injury hazard exists. The symbol is comprised of an equilateral triangle enclosing an exclamation mark.



Signal Words

Listed below are the signal words that are used throughout this manual followed by their descriptions and associated symbols. When the words **DANGER**, **WARNING** and **CAUTION** are used in this manual they will be followed by important safety information that must be carefully adhered to.

The word **DANGER** preceded by the safety alert symbol indicates that an imminently hazardous situation exists that, if not avoided, will result in death or serious injury to personnel.



The word **WARNING** preceded by the safety alert symbol indicates that a potentially hazardous situation exists that, if not avoided, could result in death or serious injury to personnel.



The word **CAUTION** preceded by the safety alert symbol indicates that a potentially hazardous situation exists which, if not avoided, may result in minor or moderate injury.



The word **CAUTION** without the safety alert symbol indicates a potentially hazardous situation exists which, if not avoided, may result in equipment and property damage.

CAUTION

Special Symbols

To identify special hazards, other symbols may appear in conjunction with the **DANGER, WARNING** and **CAUTION** signal words. These symbols indicate areas that require special and/or strict adherence to the procedures to prevent serious injury to personnel or death.

Electrical Hazard Symbol

A symbol which indicates a hazard of injury from electrical shock or burn. It is comprised of an equilateral triangle enclosing a lightning bolt.



Explosion Hazard Symbol

A symbol which indicates a hazard of injury from exploding parts. It is comprised of an equilateral triangle enclosing an explosion image.



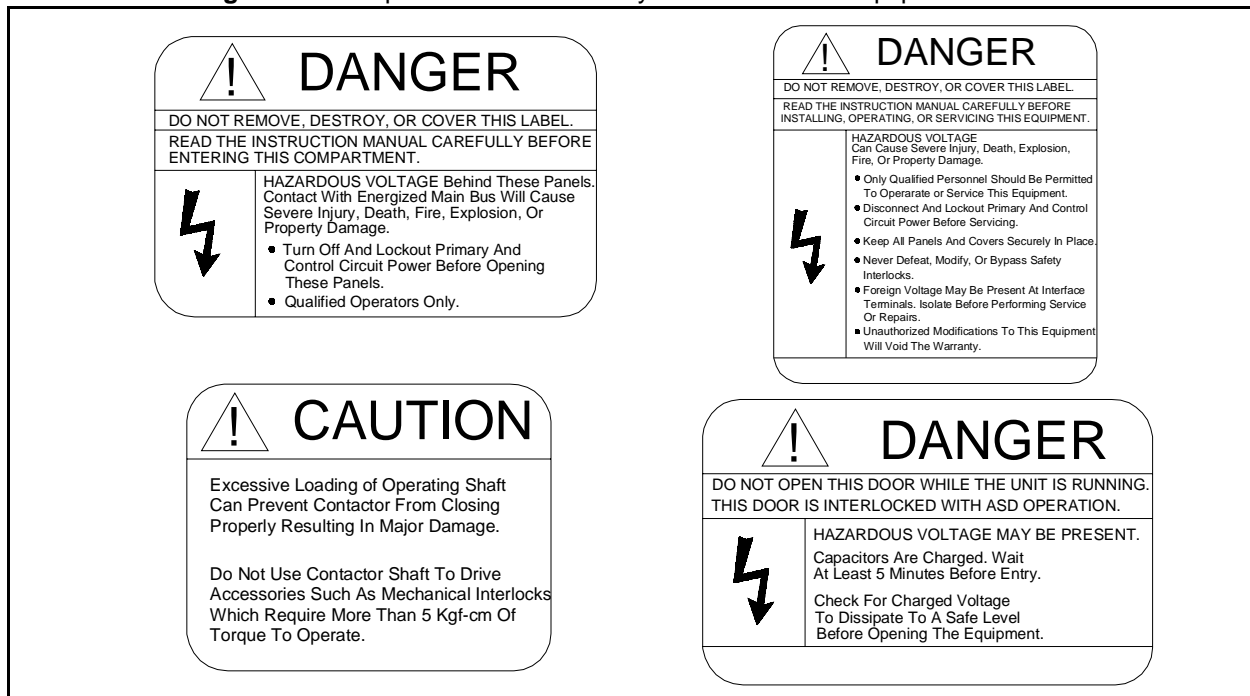
Equipment Warning Labels

DO NOT attempt to install, operate, perform maintenance, or dispose of this equipment until you have read and understood all of the product labels and user directions that are contained in this manual.

Shown below are examples of safety labels that may be found attached to the equipment. **DO NOT** remove or cover any of the labels. If the labels are damaged or if additional labels are required, contact your Toshiba sales representative for additional labels.

Labels attached to the equipment are there to provide useful information or to indicate an imminently hazardous situation that may result in serious injury, severe property and equipment damage, or death if the instructions are not followed.

Figure 1. Examples of labels that may be found on the equipment.



Qualified Personnel

Installation, operation, and maintenance shall be performed by **Qualified Personnel Only**. A **Qualified Person** is one that has the skills and knowledge relating to the construction, installation, operation, and maintenance of the electrical equipment and has received safety training on the hazards involved (Refer to the latest edition of NFPA 70E for additional safety requirements).

Qualified Personnel shall:

- Have carefully read the entire operation manual.
- Be familiar with the construction and function of the **Q7 Flow**, the equipment being driven, and the hazards involved.
- Able to recognize and properly address hazards associated with the application of motor-driven equipment.
- Be trained and authorized to safely energize, de-energize, ground, lockout/tagout circuits and equipment, and clear faults in accordance with established safety practices.
- Be trained in the proper care and use of protective equipment such as safety shoes, rubber gloves, hard hats, safety glasses, face shields, flash clothing, etc., in accordance with established safety practices.
- Be trained in rendering first aid.

For further information on workplace safety visit www.osha.gov.

Equipment Inspection

- Upon receipt of the equipment inspect the packaging and equipment for shipping damage.
- Carefully unpack the equipment and check for parts that may have been damaged during shipping, missing parts, or concealed damage. If any discrepancies are discovered, it should be noted with the carrier prior to accepting the shipment, if possible. File a claim with the carrier if necessary and immediately notify your Toshiba sales representative.
- **DO NOT** install or energize equipment that has been damaged. Damaged equipment may fail during operation resulting in equipment damage or personal injury.
- Check to see that the rated capacity and the model number specified on the nameplate conform to the order specifications.
- Modification of this equipment is dangerous and must not be performed except by factory trained representatives. When modifications are required contact your Toshiba sales representative.
- Inspections may be required before and after moving installed equipment.
- Keep the equipment in an upright position.
- Contact your Toshiba sales representative to report discrepancies or for assistance if required.

Handling and Storage

- Use proper lifting techniques when moving the **Q7 Flow**; including properly sizing up the load, getting assistance, and using a forklift if required.
- Store in a well-ventilated covered location and preferably in the original carton if the equipment will not be used upon receipt.
- Store in a cool, clean, and dry location. Avoid storage locations with extreme temperatures, rapid temperature changes, high humidity, moisture, dust, corrosive gases, or metal particles.

- The storage temperature range of the **Q7 Flow** is 14° to 104° F (-10 to 40° C).
- Do not store the unit in places that are exposed to outside weather conditions (i.e., wind, rain, snow, etc.).
- Store in an upright position.

Disposal

Never dispose of electrical components via incineration. Contact your state environmental agency for details on disposal of electrical components and packaging in your area.

Installation Precautions

Location and Ambient Requirements

- The Toshiba **Q7 Flow** is intended for permanent installations only.
- Select a mounting location that is easily accessible, has adequate personnel working space, and adequate illumination for adjustment, inspection, and maintenance of the equipment (refer to 2002 NEC Article 110-13).
- **Do Not** mount the **Q7 Flow** in a location that would produce catastrophic results if it were to fall from its mounting location (equipment damage or injury).
- **Do Not** mount the **Q7 Flow** in a location that would allow it to be exposed to flammable chemicals or gasses, water, solvents, or other fluids.
- The ambient operating temperature range of the **Q7 Flow** is 14° to 104° F (-10 to 40° C).
- The installation location shall not be exposed to direct sunlight.
- Avoid installation in areas where vibration, heat, humidity, dust, fibers, metal particles, explosive/corrosive mists or gases, or sources of electrical noise are present.
- Allow proper clearance spaces for installation. Do not obstruct the ventilation openings. Refer to the section titled **Installation and Connections** of the **Q7 ASD Installation and Operation Manual** (P/N 57246) for further information on ventilation requirements and installation.

Mounting Requirements

- Only **Qualified Personnel** should install this equipment.
- Install the unit in a secure and upright position in a well-ventilated area.
- A noncombustible insulating floor or mat should be provided in the area immediately surrounding the electrical system at the place where maintenance operations are to be performed.
- Installation should conform to the **2002 National Electrical Code — Article 110 (NEC) (Requirements For Electrical Installations)**, all regulations of the **Occupational Safety and Health Administration**, and any other applicable national, regional, or industry codes and standards.
- Installation practices should conform to the latest revision of NFPA 70E Electrical Safety Requirements for Employee Workplaces.
- It is the responsibility of the person installing the **Q7 Flow** or the electrical maintenance personnel to ensure that the unit is installed into an enclosure that will protect personnel against electric shock.

Conductor Requirements and Grounding



- Use separate metal conduits for routing the input power, output power, and control circuits and each shall have its own ground cable.
- A separate ground cable should be run inside the conduit with the input power, output power, and control circuits.
- **DO NOT** connect control terminal strip return marked **CC** to earth ground.
- Always ground the unit to prevent electrical shock and to help reduce electrical noise.
- It is the responsibility of the person installing the **Q7 Flow** or the electrical maintenance personnel to provide proper grounding and branch circuit protection in accordance with the **2002 NEC** and any applicable local codes.

The Metal Of Conduit Is Not An Acceptable Ground.

Power Connections



Contact With Energized Wiring Will Cause Severe Injury Or Death.

- Turn off, lockout, and tagout all power sources before proceeding to connect the power wiring to the equipment.
- Ensure the correct supplied voltage, wiring used, and system type for the application (refer to NEC Article 300 – Wiring Methods and Article 310 – Conductors For General Wiring). Size the branch circuit conductors in accordance with NEC Table 310.16.
- Only after ensuring that all power sources are turned off and isolated in accordance with established lockout/tagout procedures, shall a three-phase power source of the correct voltage be connected to the input terminals and the system output terminals be connected to a motor.

- Adhere to the recommended conductor sizes listed in the section titled Cable/Terminal Specifications on pg. 38. If multiple conductors are used in parallel for the input or output power, each branch of the parallel set shall have its own conduit and not share its conduit with other parallel sets (i.e., place U1, V1, and W1 in one conduit and U2, V2, and W2 in another) (refer to NEC Article 300.20 and Article 310.4). National and local electrical codes should be referenced if three or more power conductors are run in the same conduit (refer to 2002 NEC Article 310 adjustment factors).
- Ensure that the 3-phase input power is **Not** connected to the output of the **Q7 Flow**. This will damage the system and may cause injury to personnel.
- Do not install the **Q7 Flow** if it is damaged or if it is missing any component(s).
- **Do Not** connect resistors across terminals PA – PC or PO – PC. This may cause a fire.
- Ensure the correct phase sequence and the desired direction of motor rotation in the **Bypass** mode (if applicable).
- Turn the power on only after attaching and/or securing the front cover.

Protection

- Ensure that primary protection exists for the input wiring to the equipment. This protection must be able to interrupt the available fault current from the power line. The equipment may or may not be equipped with an input disconnect (option).
- All cable entry openings must be sealed to reduce the risk of entry by vermin and to allow for maximum cooling efficiency.
- Follow all warnings and precautions and do not exceed equipment ratings.
- If using multiple motors provide separate overload protection for each motor and use V/f control.
- External dynamic braking resistors must be thermally protected.
- It is the responsibility of the person installing the **Q7 Flow** or the electrical maintenance personnel to setup the **Emergency Off** braking system of the **Q7 Flow**. The function of the **Emergency Off** braking function is to remove output power from the drive in the event of an emergency. A supplemental braking system may also be engaged in the event of an emergency. For further information on braking systems, see **DC Injection Braking** and **Dynamic Braking Enable** in the *Q7 ASD Installation and Operation Manual*.

Note: A supplemental emergency stopping system should be used with the **Q7 Flow**.
Emergency stopping should not be a task of the **Q7 Flow** alone.

- Follow all warnings and precautions and do not exceed equipment ratings.

System Integration Precautions

The following precautions are provided as general guidelines for the setup of the **Q7 Flow** system.

- The Toshiba **Q7 Flow** is a general-purpose product. It is a system component only and the system design should take this into consideration. Please contact your Toshiba sales representative for application-specific information or for training support.
- The Toshiba **Q7 Flow** is part of a larger system and the safe operation of the **Q7 Flow** will depend on observing certain precautions and performing proper system integration.
- A detailed system analysis and job safety analysis should be performed by the systems designer and/or systems integrator before the installation of the **Q7 Flow** component. Contact your Toshiba sales representative for options availability and for application-specific system integration information if required.

Personnel Protection

- Installation, operation, and maintenance shall be performed by **Qualified Personnel Only**.
- A thorough understanding of the **Q7 Flow** will be required before the installation, operation, or maintenance of the **Q7 Flow**.



- Rotating machinery and live conductors can be hazardous and shall not come into contact with humans. Personnel should be protected from all rotating machinery and electrical hazards at all times.
- Insulators, machine guards, and electrical safeguards may fail or be defeated by the purposeful or inadvertent actions of workers. Insulators, machine guards, and electrical safeguards are to be inspected (and tested where possible) at installation and periodically after installation for potential hazardous conditions.
- Do not allow personnel near rotating machinery. Warning signs to this effect shall be posted at or near the machinery.
- Do not allow personnel near electrical conductors. Human contact with electrical conductors can be fatal. Warning signs to this effect shall be posted at or near the hazard.
- Personal protection equipment shall be provided and used to protect employees from any hazards inherent to system operation.
- Follow all warnings and precautions and do not exceed equipment ratings.

System Setup Requirements

- When using the **Q7 Flow** as an integral part of a larger system, it is the responsibility of the **Q7 Flow** installer or maintenance personnel to ensure that there is a fail-safe in place, i.e., an arrangement designed to switch the system to a safe condition if there is a fault or failure.
- System safety features should be employed and designed into the integrated system in a manner such that system operation, even in the event of system failure, will not cause harm or result in personnel injury or system damage (i.e., E-Off, Auto-Restart settings, System Interlocks, etc.).
- The programming setup and system configuration of the **Q7 Flow** may allow it to start the motor unexpectedly. A familiarity with the Auto-restart settings is a requirement to use this product.
- Improperly designed or improperly installed system interlocks may render the motor unable to start or stop on command.
- The failure of external or ancillary components may cause intermittent system operation, i.e., the system may start the motor without warning.
- There may be thermal or physical properties, or ancillary devices integrated into the overall system that may allow for the **Q7 Flow** to start the motor without warning. Signs at the equipment installation must be posted to this effect.
- If a secondary magnetic contactor (MC) is used between the ASD and the load, it should be interlocked to halt the ASD before the secondary contact opens. If the output contactor is used for bypass operation, it must be interlocked such that commercial power is never applied to the ASD output terminals (U, V, W).
- Power factor improvement capacitors or surge absorbers must not be installed on the output of the **Q7 Flow**.

- Use of the built-in system protective features is highly recommended (i.e., E-Off, Overload Protection, etc.).
- The operating controls and system status indicators should be clearly readable and positioned where the operator can see them without obstruction.
- Additional warnings and notifications shall be posted at the equipment installation location as deemed required by **Qualified Personnel**.
- Follow all warnings and precautions and do not exceed equipment ratings.

Operational and Maintenance Precautions



- Turn off, lockout, and tagout the main power, the control power, and instrumentation connections before inspecting or servicing the drive, or opening the door of the enclosure.
- Turn off, lockout, and tagout the main power, the control power, and instrumentation connections before proceeding to disconnect or connect the power wiring to the equipment.
- The capacitors of the **Q7 Flow** maintain a residual charge for a period of time after turning the off the **Q7 Flow**. The required time for each system typeform is indicated with a cabinet label and a **Charge LED**. Wait for at least the minimum time indicated on the enclosure-mounted label and ensure that the **Charge LED** has gone out before opening the door of the **Q7 Flow** once the power has been turned off.
- Turn the power on only after attaching (or closing) the front cover and **Do Not** remove the front cover of the **Q7 Flow** when the power is on.
- **Do Not** attempt to disassemble, modify, or repair the system. Call your Toshiba sales representative for repair information.
- Do not place any objects inside of the **Q7 Flow**.
- If the system should emit smoke or an unusual odor or sound, turn the power off immediately.
- The heat sink and other components may become extremely hot to the touch. Allow the unit to cool before coming in contact with these items.
- Remove power from the **Q7 Flow** during extended periods of non-use.
- The system should be inspected periodically for damaged or improperly functioning parts, cleanliness, and to ensure that the connectors are tightened securely.
- Ensure that the **Run** functions (**F**, **R**, **Preset Speed**, etc.) of the **Q7 Flow** are off before performing a **Reset**. The post-reset settings may allow the motor to start unexpectedly.
- **Retry** or **Reset** settings may allow the motor to start unexpectedly. Warnings to this effect should be clearly posted on or near the **Q7 Flow** and the motor.
- In the event of a power failure, the motor may restart after power is restored.
- Follow all warnings and precautions and do not exceed equipment ratings.
- Use caution when setting the output frequency. Over speeding a motor decreases its ability to deliver torque and may result in damage to the motor and/or the driven equipment.
- The **Q7 Flow** is designed to operate NEMA B motors. Consult with your sales representative before using the **Q7 Flow** for special applications such as with an explosion-proof motor or applications with a piston load.

DO NOT install, operate, perform maintenance, or dispose of this equipment until you have read and understood all of the product warnings and user directions. Failure to do so may result in equipment damage, operator injury, or loss of life.

CE Compliance Requirements

In addition to the local and regional safety requirements, this section describes additional criteria that must be met to qualify for **European Conformity (CE)** certification. All relevant apparatus placed on the European market is required to comply to the European Community directive on electromagnetic compatibility (EMC). The following instructions provide a means of compliance for the **Q7 Flow**. A Technical Construction File (TFC) indicates the rationale used to declare compliance and is on file at Toshiba International Corporation, Houston, Texas, U.S.A.

Using RCD Protection

Where a residual-current-operated protective device (RCD) is used to guard against direct or indirect contact, only an RCD of Type B is allowed on the supply side of this Electronic Equipment.

Otherwise, another protective measure shall be applied, such as separation of the Electronic Equipment from the environment by double or reinforced insulation, or isolation of the Electronic Equipment and supply side by a transformer.

EMC Installation Guidelines

All systems placed on the European market are required to comply with the European Community directive regarding electromagnet compatibility (EMC). Toshiba ensures that all systems deployed in the European market have been screened and are in 100% compliance with the following standards:

- Radiated Interference: EN 55011 Group 1 Class A
- Mains Interference: EN 55011 Group 1 Class A
- Radiated Susceptibility: IEC 801-3 1984
- Conducted RFI Susceptibility: prEN55101-4 (prIEC801-6) Doc 90/30270
- Electrostatic Discharge: IEC801-2 1991
- Electrical Fast Transient: IEC 801-4 1988
- Surge: IEC1000-4-5 1995 2 KV line-to-line, 4 KV line-to-earth
- Voltage Interruption: IEC 1000-4-11

General EMC Guidelines for Consideration

- Input filters of the appropriate rating shall be used.
- Proper grounding is a requirement.
- Grounds shall be kept to the minimum length to accomplish the connection.
- Grounds shall have low RF impedance.
- A central ground shall be employed in a complex system.
- Paint or corrosion can hamper good grounding; remove as required.
- Keep control and power cabling separated. Minimize exposed (unscreened) cable.
- Use 360° shielded connections where possible.

CE Compliant Installation Guidelines

The **Q7 Flow** should be installed in accordance with the following guidelines.

1. **Filtering** — An input filter shall be used with the ASD. A Schaffner FN258 series input filter of the appropriate rating shall be used and mounted adjacent to the ASD.
2. **Mechanical** — The ASD and the associated equipment shall be mounted on a flat metallic backplane. A minimum space of 5 cm (2 inches) shall exist between the ASD and the filter to allow for ventilation. The filter output cable is to be connected from the bottom of the filter to the ASD power input and is to be the minimum length required for a connection.

Units received as an Open Chassis shall not be placed into operation until being placed into an approved enclosure that will protect personnel against electrical shock.

Opening and closing of enclosures or barriers should be possible only with the use of a key or a tool.

3. **Cabling** — The cables of the input power, filter, and motor shall be of the appropriate current rating. The cables shall be connected in accordance with the guidelines of the manufacturer and the applicable local and national agencies. A 4-core screened cable (such as RS 379-384) is to be used for the power and earth connections to minimize RF emissions. Control cabling must be screened using P/N RS 367-347 or a similar component.
4. **Grounding** — The mains (input) ground shall be connected at the ground terminal provided on the filter. The filter and motor shall be grounded at the ground terminals provided in the ASD.
5. **Screening** — The mains (input) screen is to be connected to the metallic back-plane at the filter; remove any finish coating as required. The screen over the filter output cables, the motor cable screen, and the control wire screens must be connected to the ASD case using glands or conduit connectors. The motor cable screen shall be connected to the motor case. When using a braking resistor, the cabling between the resistor and ASD shall also be screened. This screen shall connect to both the ASD enclosure and the resistor enclosure.

See the **Q7 Flow** Filter Selection below for the recommended input filters for a given typeform.

Q7 Flow Filter Selection Table			
230V	Filter Number	460V	Filter Number
Q72010B	FN258-7	Q74015B	FN258-7
Q72015B		Q74025B	
Q72025B		Q74035B	
Q72035B	FN258-16	Q74055B	FN258-16
Q72055B		Q74080B	
Q72080B	FN258-30	Q74110B	FN258-30
Q72110B	FN258-42	Q74160B	FN258-42
Q72160B	FN258-75	Q74220B	FN258-42
Q72220B	FN258-100	Q74270B	FN258-55
Q72270B		Q74330B	
Q72330B	FN258-130	Q74400B	FN258-75
Q72400B	FN258-180	Q74500B	FN258-100
Q72500B	FS5236-180	Q74600B	FS5236-130
Q72600B	FS5236-300	Q74750B	FS5236-180
Q72750B		Q7410KB	
Q7210KB	FS5236-500	Q7412KB	FS5236-300
Q7212KB		Q7415KB	
Q7215KB		Q7420KB	
		Q7425KB	
		Q7430KB	FS5236-500
		Q7435KB	
		Q7440KB	

Q7 Flow Installation

The **Q7** system is available in two primary system configurations: the stand-alone ASD unit and the **Q7 Flow** (stand-alone unit enclosed within the integrated enclosure). The **Q7 Flow** is further categorized into three system configurations identified by the part number suffixes of IA, IC, and IE. See Figure 4. on pg. 20, Figure 5. on pg. 21, and Figure 6. on pg. 22 for further information on the IA, IC, and IE variations.

This manual will provide installation and connection information for the **Q7 Flow** only. This manual is intended to be used in conjunction with the **Q7 ASD Installation and Operation Manual** (P/N 57246).

The **Q7 Flow** may be ordered with the optional system protection hardware and the bypass circuitry designed to facilitate system diagnostics and maintenance operations. The available **Q7 Flow** typeforms and HP ranges for the 230- and 460-volt units are listed in the section titled Current/Voltage Specifications on pg. 40.

Installation Notes

Input Power

The **Q7 Flow** input voltage should remain within 10% of the specified input voltage range. Input voltages approaching the upper or lower limit settings may require that the overvoltage and undervoltage stall protection level parameters be adjusted. Voltages outside of the permissible tolerance should be avoided.

The input power frequency should be ± 2 Hz of the specified input frequency.

Do not use an adjustable speed drive with a motor that has a higher power rating than the rated output of the adjustable speed drive.

Control Signal Isolation

Interface problems may occur when the **Q7 Flow** is used in conjunction with some types of process controllers. Signal isolation may be required to prevent controller and/or **Q7 Flow** malfunctions. The **Q7 Flow** option, the ASD-ISO-1, provides isolation of the **Control Board** output circuit from the **AM/FM** output and from the **II** input (for further information on the ASD-ISO-1 option contact your Toshiba sales representative or contact the manufacturer of the process controller for additional information on controller compatibility and signal isolation).

Jumper Requirements

The **Q7 Flow** is shipped with jumpers connected to the following terminals:

- ST to CC (coasts to stop if removed),
- S4 to CC (Emergency Off trip if removed),
- CIA to CIB (Customer Interlock; user-specific), and
- DRA to DRB (Disables the system if open).

All four jumper connections are required for normal operation of the **Q7 Flow** while in the default settings configuration (see the **Q7 ASD Installation and Operation Manual** P/N 57246 for information on changing the default settings).

Output Terminals

Do Not apply commercial power to the output terminals **T1/U**, **T2/V**, or **T3/W**.

Isolate the **Q7 Flow** from the motor before megging the motor.

When a brake-equipped motor is connected to the **Q7 Flow**, it is possible that the brake may not release at startup because of insufficient voltage. To avoid this condition, **Do Not** connect the brake or the brake contactor to the output of the **Q7 Flow**.

Q7 Flow Mounting and Connections

The **Q7 Flow** may be set up initially by performing a few simple configuration settings. To operate properly, the **Q7 Flow** must be securely mounted and connected to a power source (3-phase AC input at the **L1/R**, **L2/S**, and **L3/T** terminals). The control terminals of the **Q7 Flow** may be used by connecting the terminals of the **Control Terminal Strip** to the proper sensors or signal input sources (see the section titled I/O and Control on pg. 15 for an expanded description of the system control options).

The output terminals of the ASD (**T1/U**, **T2/V**, and **T3/W**) must be connected to the motor that is to be controlled. See Figure 3. on pg. 19 for the connection diagram of the **Q7 Flow**.

As a minimum, the installation of the ASD shall conform to **Article 110** of the **2002 NEC**, the **Occupational Safety and Health Administration** requirements, and to any other local and regional industry codes and standards.

Mounting the ASD



The ambient operating temperature rating for the Q7 is from 14 to 104° F (-10 to 40° C). The process of converting AC to DC, and then back to AC produces heat. During normal ASD operation, up to 5% of the input energy to the ASD may be dissipated as heat.

The **Q7 Flow** should be installed securely using the four mounting holes on the top and bottom perimeter of the enclosure in a well ventilated area that is out of direct sunlight.

When installing multiple ASDs, ensure that there is a clearance space of at least 8 inches (20 cm) from the top and the bottom of adjacent units. There should be at least 5 cm (2 inches) on either side of adjacent units. For the models below 50 HP the top and bottom clearance specifications may be reduced to 4 inches (10 cm). This space ensures that adequate ventilation is provided (see the section titled Enclosure Dimensional Information and Weights on pg. 34 for additional information on mounting space requirements).

Note: *Ensure that the ventilation openings are not obstructed.*

Do Not operate the ASD with the enclosure door open.

ASDs produce high-frequency noise — steps must be taken during installation to avoid the negative effects of noise. Listed below are some examples of measures that will help to combat noise problems.

- Separate the input and output power conductors of the main circuit. Do not install the input and output wires in the same duct or in parallel with each other, and do not bind them together.
- Do not install the input or output power conductors of the main circuit and the wires of the control circuit in the same duct or in parallel with each other, and do not bind them together.
- Use shielded wires or twisted wires for the control circuits.
- Ensure that the grounding terminals (G/E) of the ASD are securely connected to ground.
- Connect a surge suppressor to every electromagnetic contactor and every relay installed near the ASD.
- Install noise filters as required.

Connecting the ASD



Refer to the section titled Installation Precautions on pg. 4 and the section titled **Lead Length Specifications** of the *Q7 ASD Installation and Operation Manual* before attempting to connect the ASD and the motor to electrical power.

System Grounding

Proper grounding helps to prevent electrical shock and to reduce electrical noise. The ASD is designed to be grounded in accordance with **Article 250** of the **2002 NEC** or **Section 10/Part One** of the **Canadian Electrical Code (CEC)**.

The grounding conductor shall be sized in accordance with **Article 250-122** of the **NEC** or **Part One-Table 6** of the **CEC**.

The Metal Of Conduit Is Not An Acceptable Ground.

The input, output, and control lines of the system shall be run in separate metal conduits and each shall have its own ground conductor.

Power Connections



L1/R, **L2/S**, and **L3/T** are the 3-phase input supply terminals for the **Q7 Flow**. An AC Reactor may be installed to the 3-phase input to the **Q7 Flow** to provide filtering of the input voltage.

T1/U, **T2/V**, and **T3/W** are the output terminals of the ASD that connect to the motor. A DC Reactor may be connected across terminals **PA** and **PO** to provide additional filtering. When not used, a jumper is connected across these terminals (see Figure 3. on pg. 19).

Filtering provides an increased line transient immunity and a lower harmonic current.

Connect the input and output power lines of the **Q7 Flow** as shown in Figure 4. on pg. 20.

Note: *In the event that the motor rotates in the wrong direction when powered up, reverse any two of the three leads connected to the motor.*

Connect the 3-phase input power to the input terminals of the **Q7 Flow** at the **L1/R**, **L2/S**, and **L3/T** terminals. Connect the output terminals **T1/U**, **T2/V**, and **T3/W** of the **Q7 Flow** to the motor. The input and output conductors and terminal lugs used shall be in accordance with the requirements listed in Cable/Terminal Specifications on pg. 38.

If conductors smaller than the recommended sizes are used in parallel for the input or output power, each branch of the parallel set shall have its own conduit and not share its conduit with other parallel sets (i.e., place **U1**, **V1**, and **W1** in one conduit and **U2**, **V2**, and **W2** in another conduit).

Note: *National and local codes should be referenced when running more than three conductors in the same conduit.*

Install a molded case circuit breaker (MCCB) or fuse between the 3-phase power source and the ASD in accordance with the **2002 NEC Article 430-102** through **430-111** and the **Fault Current** setting of the **Q7 Flow** (Electronic Thermal Protection setting).

Startup and Test

Before turning on the unit, the following checks are to be performed by **Qualified Personnel**.

- **L1/R, L2/S, and L3/T** are connected to the 3-phase input power.
- **T1/U, T2/V, and T3/W** are connected to the motor.
- The 3-phase input voltage is within the ASD setup tolerances.
- There are no shorts and all grounds are secured.
- With the previous checks confirmed, ensure that the direction of the motor rotation in the **Bypass** mode and in the ASD-driven mode is consistent.

I/O and Control

The ASD can be controlled by several input types and combinations thereof, as well as operate within a wide range of voltage levels. This section discusses the ASD control methods and supported I/O functions.

The **Control Terminal Strip** PCB (P/N 53750; shown on pg. 18) of the **Q7 Flow** supports discrete and analog I/O functions. Table 1 lists the names, the default settings (where applicable), and the descriptions of the input and output terminals of the **Control Terminal Strip** PCB.

Table 1. Input/Output terminal names and functions.

Terminal Name	Input/Output	Function (Default for programmable terminals)
ST	Discrete Input	Standby — Multifunctional programmable discrete input (connect to CC to operate the unit).
RES	Discrete Input	Reset — Multifunctional programmable discrete input.
F	Discrete Input	Forward — Multifunctional programmable discrete input.
R	Discrete Input	Reverse — Multifunctional programmable discrete input.
S1	Discrete Input	Fire Speed — Multifunctional programmable discrete input.
S2	Discrete Input	Preset Speed 2 — Multifunctional programmable discrete input.
S3	Discrete Input	Damper Fdbk — Multifunctional programmable discrete input (connect to CC to operate the unit).
S4	Discrete Input	Emergency Off — Multifunctional programmable discrete input (connect to CC to operate the unit).
CIA/CIB	Discrete Input	Customer Interlock — The CIA -to- CIB connection is accomplished via a jumper, a relay, or some other user-selected means and is required for normal system operation.
DRA/DRB	Discrete Input	Damper Response — The DRA -to- DRB connection is accomplished via limit switches at the fully-opened damper and is required for normal system operation.
RR	Analog Input	RR — Multifunctional programmable analog input (0.0 to 10 volt input — 0 to 80 Hz output).
RX	Analog Input	RX — Multifunctional programmable analog input (-10 to +10 VDC input — Unassigned).
II	Analog Input	II — Multifunctional programmable analog input (4 to 20 mADC input — Unassigned).
VI	Analog Input	VI — Multifunctional programmable analog input (0 to 10 VDC input — Unassigned).
P24	DC Output	24 VDC @ 50 mA output.
PP	DC Output	PP — 10.0 VDC voltage source for the external potentiometer.
DSA/DSB (OUT1)	Discrete Output	Damper Command — Multifunctional programmable output that is used to open/close the 120 VAC damper motor power circuit when the motor is ASD-driven (see Q7 Flow Theory of Operation on pg. 32).
OUT2 A/B	Discrete Output	Acc/Dec Complete — Multifunctional programmable output that changes state when the programmed acceleration or deceleration ramp is reached.
	Discrete Output	
FLA	Discrete Output	Fault Relay - rated at 2A/250 VAC (N.O.). Connects to FLC at power up.
FLB	Discrete Output	Fault Relay - rated at 1A/250 VAC (N.C.). Disconnects from FLC at power up.
FLC	Discrete Output	Fault Relay - rated at 2A/250 VAC (com). Connects to FLA at power up. Connects to FLB at Fault.
FP	Output	Frequency Pulse — Multifunctional programmable output that produces a pulse train that has a frequency which is based on the output frequency of the ASD.
AM	Output	Output Current — Multifunctional programmable output that produces a DC current that is proportional to the magnitude of the output current.
FM	Output	Output Frequency — Multifunctional programmable output that produces a DC current that is proportional to the magnitude of the output frequency.
CC	—	Control common (Do Not connect to Earth Gnd).
<p>Discrete Input Terminals ⇒ On = connected to CC. Analog Input Terminals reference CC. Note: Multifunctional terminals are shown in the default setting condition.</p>		

I/O Terminal Descriptions

Note: The programmable terminal assignments may be accessed and changed from their default settings as described in the *Q7 ASD Installation and Operation Manual*.

ST — The default setting for this terminal is **ST**. The function of this input as **ST** is a **Standby** mode controller (system is in **Standby** when on). As the default setting, this terminal must be connected to **CC** for normal operation. If not connected to **CC**, **Off** replaces **Output Frequency** on the LCD screen. This discrete input terminal may be programmed to any 1 of the 68 functions that are listed in the *Q7 ASD Installation and Operation Manual*.

RES — The default setting for this terminal is **Reset**. A momentary connection to **CC** resets the ASD and any fault indications from the display. **Reset** is effective when faulted only. This discrete input terminal may be programmed to any 1 of the 68 functions that are listed in the *Q7 ASD Installation and Operation Manual*.

F — The default setting for this terminal is **Forward Run**. **Forward Run** runs the motor in the **Forward** direction when it is on. This discrete input terminal may be programmed to any 1 of the 68 functions that are listed in the *Q7 ASD Installation and Operation Manual*.

R — The default setting for this terminal is **Reverse Run**. **Reverse Run** runs the motor in the **Reverse** direction when it is on. This discrete input terminal may be programmed to any 1 of the 68 functions that are listed in the *Q7 ASD Installation and Operation Manual*.

S1 — The default setting for this terminal is **Fire Speed**. The function of this input as **Fire Speed** is to run the motor at the **Preset Speed #1** setting when it is on. This terminal may be activated by a fire alarm signal or fire sensing device. This discrete input terminal may be programmed to any 1 of the 68 functions that are listed in the *Q7 ASD Installation and Operation Manual*.

S2 — The default setting for this terminal is **S2**. The function of this input as **S2** is to run the motor at **Preset Speed #2** when it is on. This discrete input terminal may be programmed to any 1 of the 68 functions that are listed in the *Q7 ASD Installation and Operation Manual*.

S3 — The default setting for this terminal is **Damper Feedback**. The function of this input as **Damper Feedback** is to complete the requirements for normal system operation as described in the section titled Q7 Flow Theory of Operation on pg. 32. This discrete input terminal may be programmed to any 1 of the 68 functions that are listed in the *Q7 ASD Installation and Operation Manual*.

S4 — The default setting for this terminal is **Emergency Off** (normally closed). The function of this input as **Emergency Off** is to remove power from the output of the ASD and may apply a supplemental braking system using the method selected at the **Emg Off Mode** selection parameter. This discrete input terminal may be programmed to any 1 of the 68 functions that are listed in the *Q7 ASD Installation and Operation Manual*.

CIA/CIB — These terminals make up the **Customer Interlock**. The **CIA-to-CIB** connection is a requirement for normal **Q7 Flow** operation. These terminals may be connected using a jumper or used to Enable/Disable the system as a function of an event or condition that opens or closes this circuit. See the section titled Q7 Flow Theory of Operation on pg. 32 for further information on these terminals.

DRA/DRB — These terminals are used to complete the **Damper Response** function. The **DRA-to-DRB** connection is a requirement for normal **Q7 Flow** operation. These terminals may be connected using a jumper or used to Enable/Disable the system as a function of an event or condition that opens or closes this circuit. See the section titled Q7 Flow Theory of Operation on pg. 32 for further information on these terminals.

RR — The default function assigned to this terminal is to carry out the **Frequency Mode #1** setting. The **RR** terminal accepts a 0 – 10 VDC analog input signal and controls the function assigned to this terminal. This input terminal may be programmed to control the speed or torque of the motor. It may also be used to regulate (limit) the speed or torque of the motor. The gain and bias of this terminal may be adjusted for application-specific suitability. See the *Q7 ASD Installation and Operation Manual* for further information on this terminal.

RX — The **RX** terminal accepts a ± 10 VDC analog input signal and controls the function assigned to this terminal. This input terminal may be programmed to control the speed, torque, or direction of the motor. It may also be used to regulate (limit) the speed or torque of the motor. The gain and bias of this terminal may be adjusted for application-specific suitability. See the *Q7 ASD Installation and Operation Manual* for further information on this terminal.

II — The **II** terminal accepts a 4 – 20 mA analog input signal and controls the function assigned to this terminal. This input terminal may be programmed to control the speed or torque of the motor and may not be used when using the **VI** input. It may also be used to regulate (limit) the speed or torque of the motor. The gain and bias of this terminal may be adjusted for application-specific suitability. See the *Q7 ASD Installation and Operation Manual* for further information on this terminal.

VI — The **VI** terminal accepts a 0 – 10 VDC analog input signal and controls the function assigned to this terminal. This input terminal may be programmed to control the speed or torque of the motor and may not be used when using the **II** input. It may also be used to regulate (limit) the speed or torque of the motor. The gain and bias of this terminal may be adjusted for application-specific suitability. See the *Q7 ASD Installation and Operation Manual* for further information on this terminal.

P24 — +24 VDC @ 50 mA power supply for customer use.

PP — The function of output **PP** is to provide a 10 VDC output that may be divided using a potentiometer. The tapped voltage is applied to the **RR** input to provide manual control of the **RR** programmed function.

DSA/DSB (OUT1) — The default function assigned to this output terminal is **Damper Command**. This output terminal may be programmed to provide an indication that 1 of 60 possible events has taken place. This function may be used to signal external equipment or to activate the brake. The **OUT1** contact is rated at 2A/250 VAC.

OUT2 — The default function assigned to this output terminal is **ACC/DEC Complete**. This output terminal may be programmed to provide an indication that 1 of 60 possible events has taken place. This function may be used to signal external equipment or to activate the brake. The **OUT2** contact is rated at 2A/250 VAC.

FLA — One of two contacts that, under user-defined conditions, connect to **FLC**.

FLB — One of two contacts that, under user-defined conditions, connect to **FLC**.

FLC — **FLC** is the middle leg of a single-pole double-throw (relay) switch. This **FLC** contact of the relay is switched, under user-defined conditions, between **FLB** and **FLA**. This output contact may be programmed to switch between **FLB** and **FLA** as a function of any 1 of the 60 conditions listed in the *Q7 ASD Installation and Operation Manual*.

Note: The **FLA** and **FLC** contacts are rated at 2A/250 VAC. The **FLB** contact is rated at 1A/250 VAC.

FP — The default function assigned to this open collector output terminal is **Output Frequency**. This output terminal produces an output pulse train that has a frequency which is proportional to the magnitude of the function assigned to this terminal. This output terminal may be programmed to provide an output that is a function of any 1 of the 31 functions listed in the *Q7 ASD Installation and Operation Manual*.

AM — The default function assigned to this output terminal is **Output Current**. This output terminal produces an output current that is proportional to the magnitude of the function assigned to this terminal. This output terminal may be programmed to provide an output that is a function of any 1 of the 33 functions listed in the *Q7 ASD Installation and Operation Manual*.

FM — The default function assigned to this output terminal is **Output Frequency**. This output terminal produces an output current that is proportional to the magnitude of the function assigned to this terminal. This output terminal may be programmed to provide an output that is a function of any 1 of the 33 functions listed in the *Q7 ASD Installation and Operation Manual*.

CC — Control common (**Do Not** connect to **Earth Gnd**).

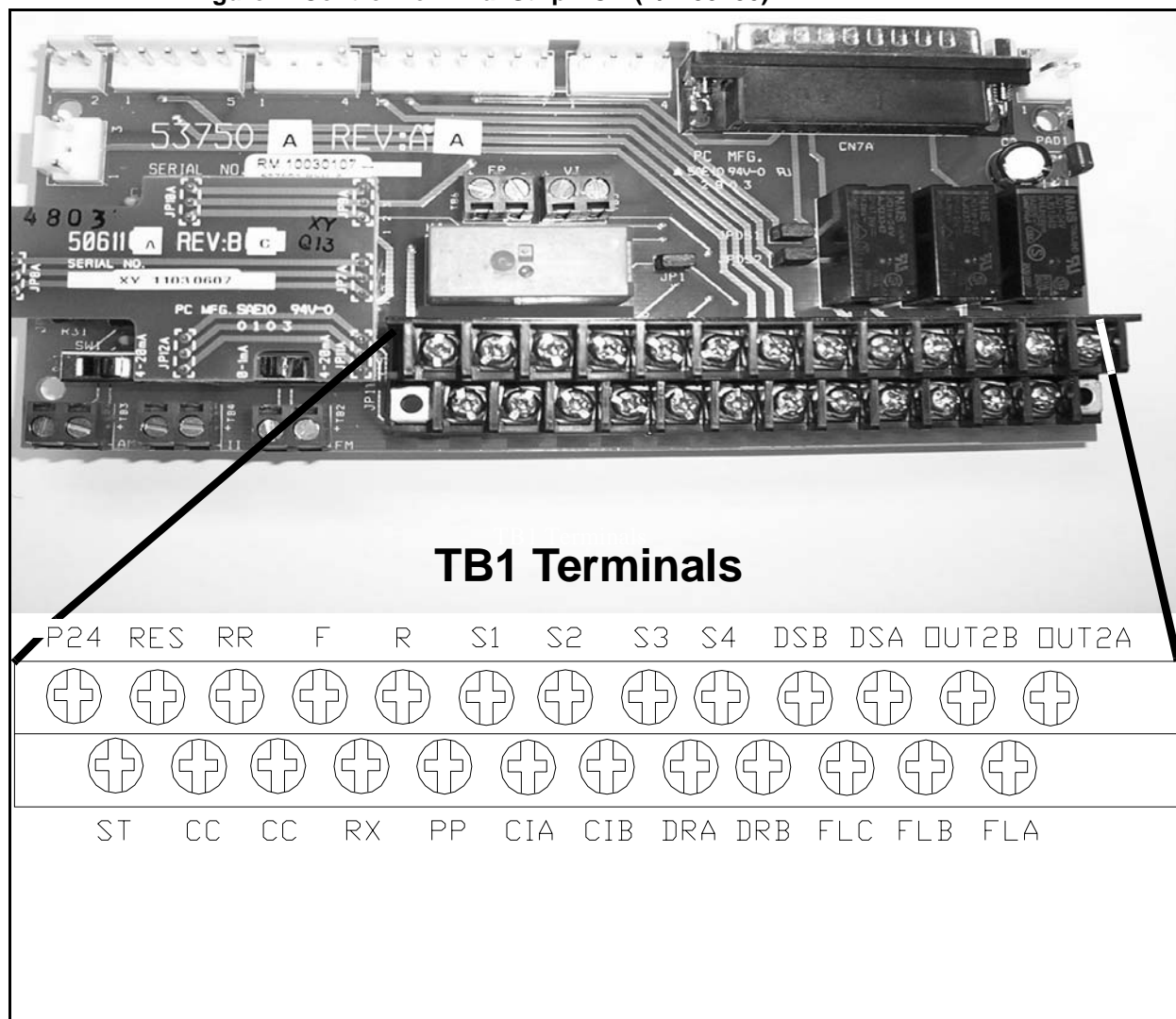
Q7 Flow Monitoring/Control Interface

Note: See the *Q7 ASD Installation and Operation Manual (P/N 57246)* for detailed information on Q7 control.

The Control Terminal Strip PCB (P/N 53750) serves as a monitoring and control interface for the Q7 Flow. The Control Terminal Strip PCB receives input from ancillary devices, transducers that monitor system variables, or from the user via the keypad. The Control Terminal Strip PCB also provides output signals that may be used to control ancillary devices, close a contact, notify the user, or monitor system variables.

See Figure 3. on pg. 19 for a connection diagram of the Control Terminal Strip PCB (PCB12).

Figure 2. Control Terminal Strip PCB (P/N 53750).

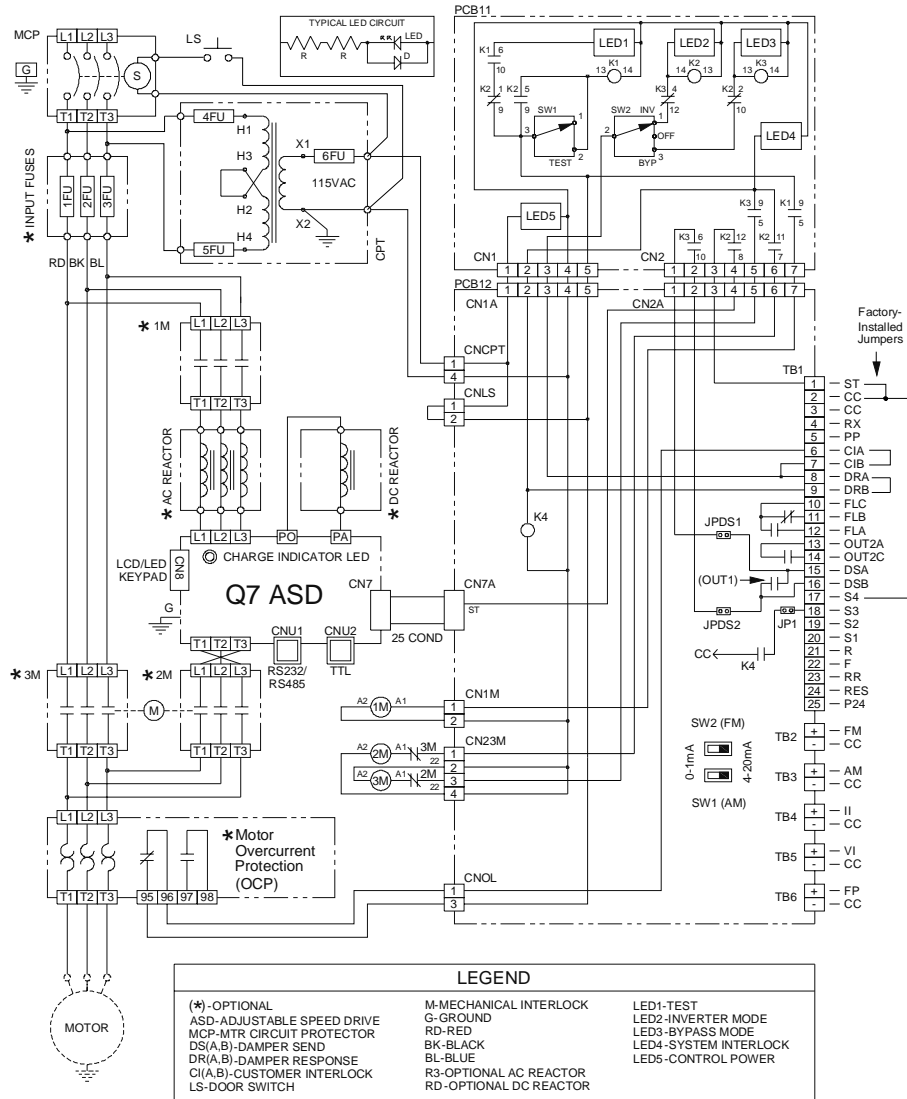


Typical Q7 Flow Connection Diagram

Three variations of the Q7 Flow system are available. The variations may include bypass circuitry, optional protection features, and/or additional filtering. The different systems are identified by the IA, IC, or IE part number suffix as shown in figures 4, 5, and 6.

Figure 3. Q7 Flow typical connection diagram.

Note: When connecting multiple wires to the PA, PB, PC, or PO terminals, do not connect a solid wire and a stranded wire to the same terminal.

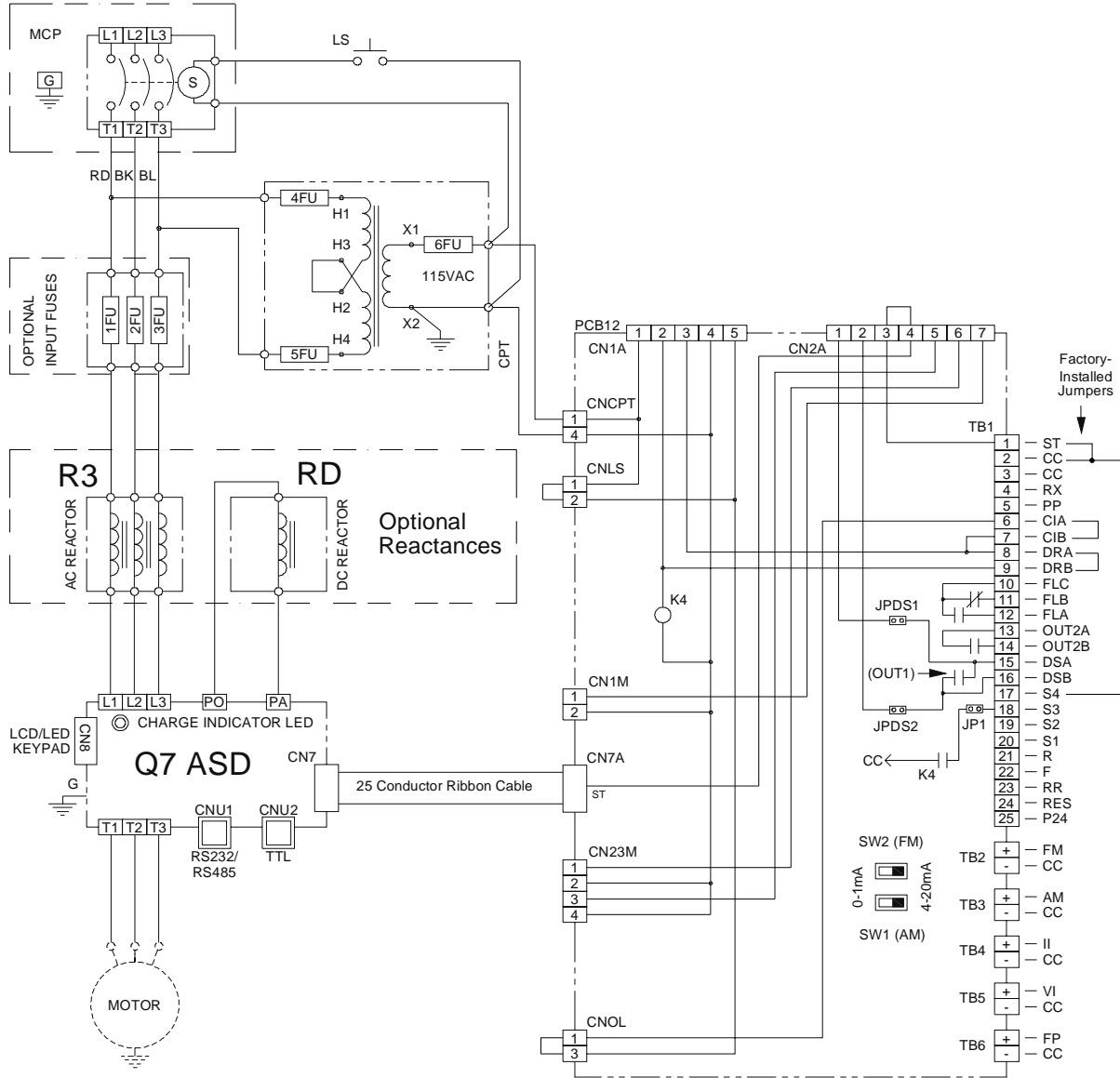


DO NOT CONNECT CC TO EARTH GROUND

Note: The negative terminals of the AM, FM, and II analog inputs are connected to CC unless isolated via the optional ASD-TB1-AC1 PCBA.

Note: See alternative ST-to-CC activation configuration on pg. 26.

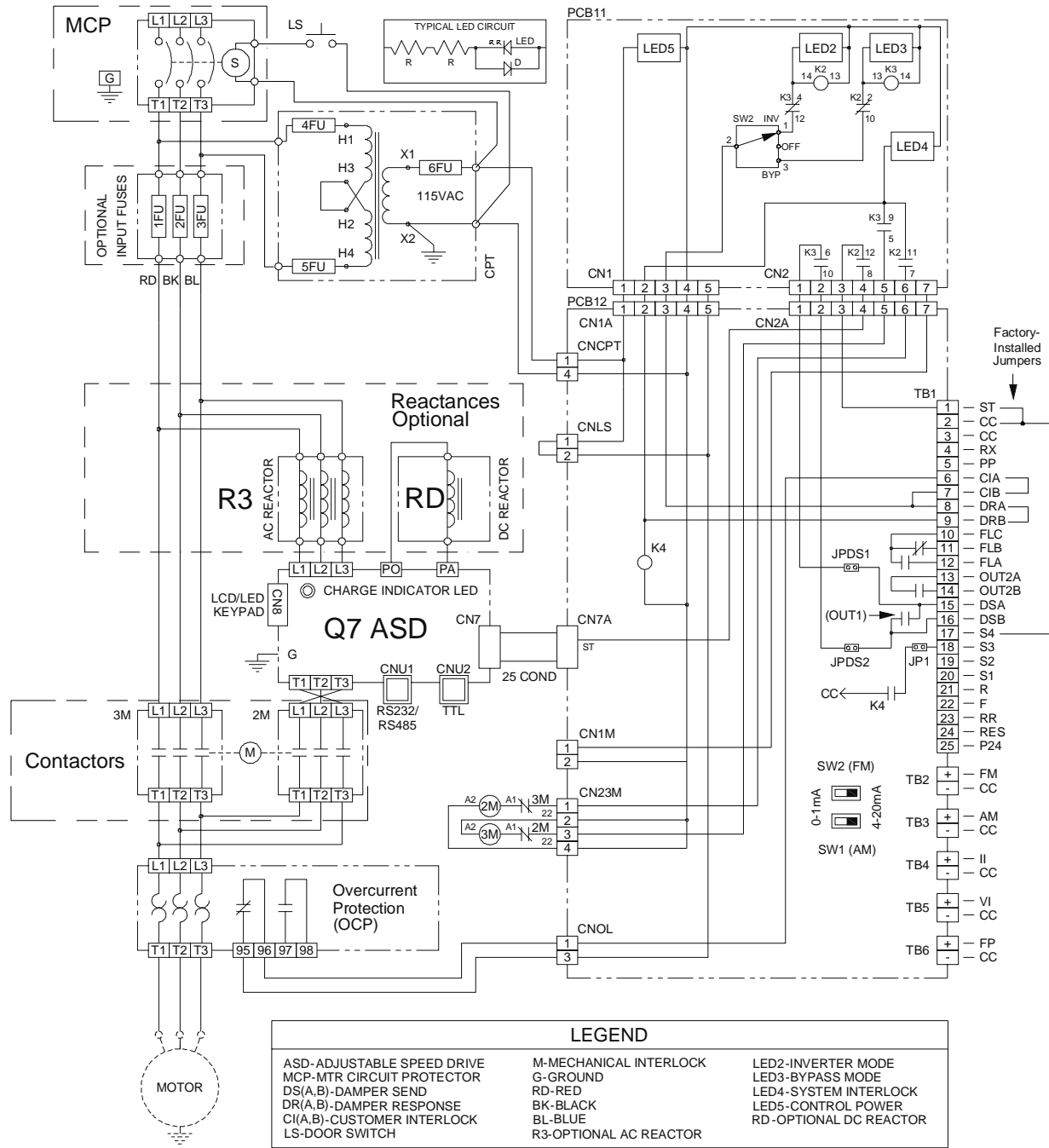
Figure 4. Q7 Flow-IA typical connection diagram.



LEGEND	
ASD-ADJUSTABLE SPEED DRIVE	G-GROUND
MCP-MTR CIRCUIT PROTECTOR	RD-RED
DS(A,B)-DAMPER SEND	BK-BLACK
DR(A,B)-DAMPER RESPONSE	BL-BLUE
CI(A,B)-CUSTOMER INTERLOCK	R3-OPTIONAL AC REACTOR
LS-DOOR SWITCH	RD-OPTIONAL DC REACTOR

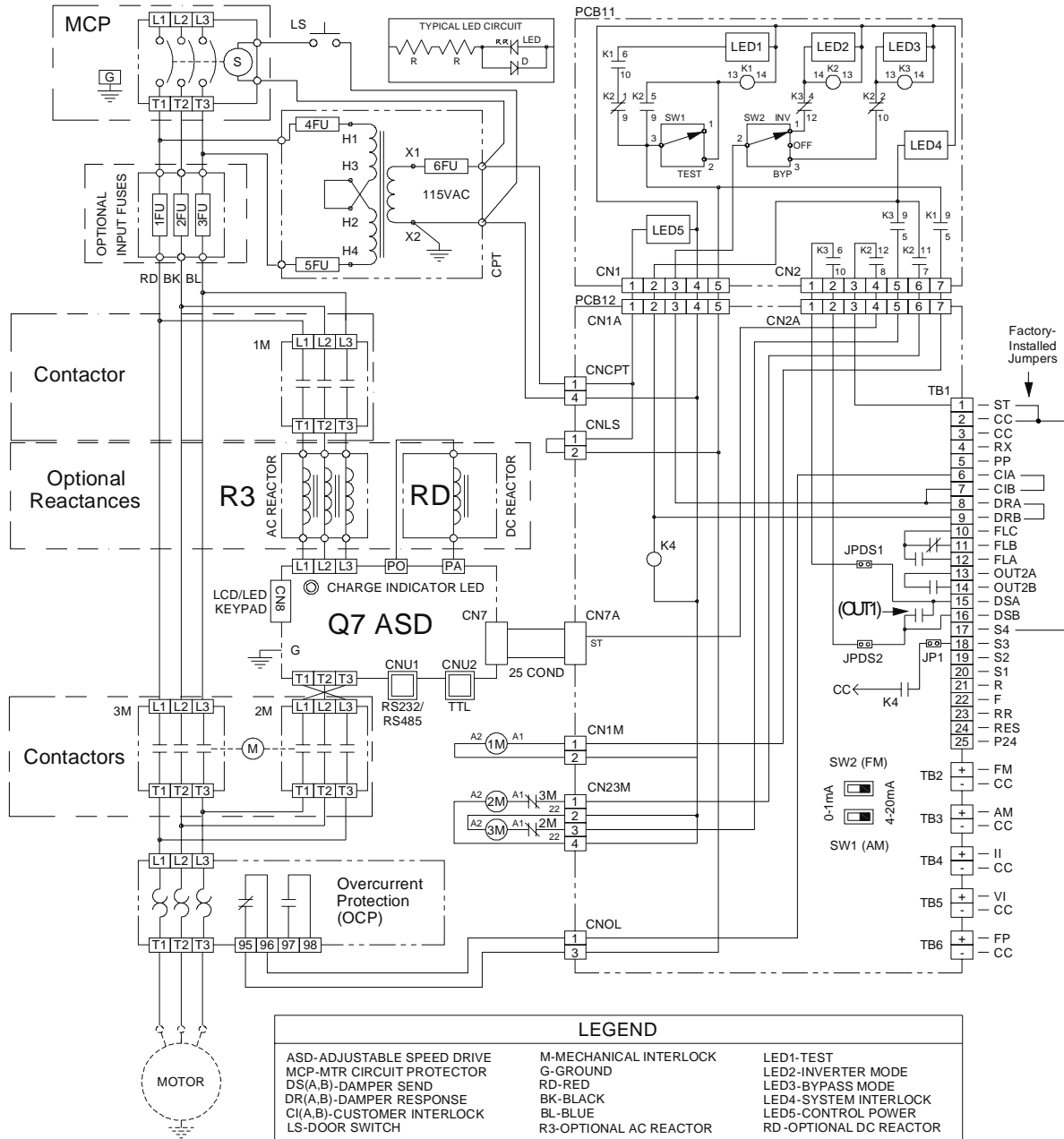
DO NOT CONNECT CC TO EARTH GROUND

Figure 5. Q7 Flow-IC typical connection diagram.



DO NOT CONNECT CC TO EARTH GROUND

Figure 6. Q7 Flow-IE typical connection diagram.



DO NOT CONNECT CC TO EARTH GROUND

System Protection

The **Q7 Flow** has protection features that are designed to protect the ASD and the motor from overload/overcurrent damage and from the undesirable effects of undervoltage operation. Because of the different types of overcurrent conditions that may occur (e.g., inrush current, short circuit current, extended overloads, etc.), the **Q7 Flow** is equipped to protect the system from start-up overcurrent and running overcurrent damage. Both protection mechanisms require an application-specific adjustment for performance optimization and the minimization of nuisance tripping.

There are two system operating modes: *Q7 Flow*-driven and Bypass operation. When the motor is being driven by the ASD of the **Q7 Flow**, the primary overcurrent protection and extended overload protection for the ASD is accomplished via the **Electronic Thermal Protection** setting of the **Q7 Flow**. This parameter should be set as a ratio of the FLA of the ASD to the FLA of the motor. The power unit of the **Q7 Flow** is rated for 200,000 Amps Interrupting Capacity (AIC). The bypass circuit is rated for 100,000 Amps Interrupting Capacity.

When the motor is being driven by the ASD of the **Q7 Flow**, the primary overcurrent protection and extended overload protection is accomplished via the **Electronic Thermal Protection** setting of the **Q7 Flow**.

Overload protection for the Bypass mode of operation is accomplished via the Motor Circuit Protector shown on pg. 28 and the Overload Circuit Protector shown on pg. 29.

ASD Protection

The **Q7 Flow** is designed and manufactured to accommodate a wide range of voltage and current requirements; from the 0.75 HP to the 350 HP ASD (Typeform). Each typeform is designed to operate at 100% output continuously and can operate at 110% for up to 60 seconds. A trip will be incurred if the design specifications are exceeded for a given typeform.

ASD overload protection is accomplished via the ASD software which can be configured to disable the system in the event of an overload. Using the **Electronic Thermal Protection** setting, the ASD may be properly matched to the motor being driven and the application.

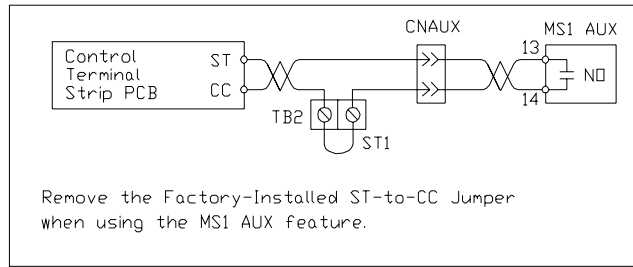
The short-circuit protection, which is provided by hardware and software, disables the system in the event of a fault.

On some devices the system may be disabled via the **MS1 AUX** relay-controlled **ST-to-CC** connection (see Figure 7).

The **MS1 AUX** relay circuit is normally-open and closes the **ST-to-CC** connection (via **ST1**) only after normal system power is available. The **MS1 AUX** relay circuit prohibits the **ST-to-CC** connection in the event that the **MS1** contactor fails to close during start up or if the **MS1** contactor opens while the **Q7 Flow** is running.

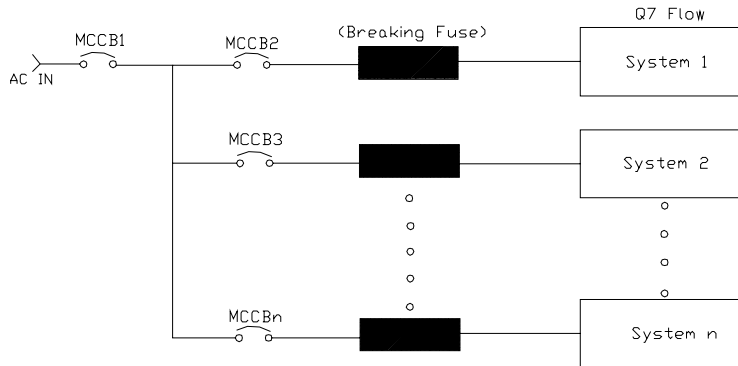
For the 230 volt ASD this feature is available on the 40 HP and above systems and on the 460 volt ASD this feature is available on the 75 HP and above systems.

Figure 7. ST activation using the MS1 AUX circuit configuration.



All **Q7 Flow** ASDs are equipped with internal DC bus fuses. However, internal primary power input fuses are optional. When connecting two or more drive systems that have no internal fuses to the same power line as shown in Figure 8, it will be necessary to select a circuit-breaking configuration that will ensure that if a short circuit occurs in system 1, only MCCB2 trips, not MCCB1. If it is not feasible to use this configuration, insert a fuse between MCCB2 and system 1.

Figure 8. Circuit breaker configuration.



Read and understand all safety warnings before operating this equipment!

Motor Protection

Motor circuit protection is accomplished using circuit breakers that have adjustable trip thresholds. The threshold settings must be properly matched the motor being driven and the application. The circuit breakers are set to the minimum current value of the circuit breaker at the factory and must be adjusted for the motor being used and to properly match the requirements of the application.

The motor protection hardware is comprised of a **Motor Circuit Protector (MCP)** at the 3-phase system input and an **Overload Circuit Protector (OCP)** connected to the motor (see Figure 3. on pg. 19). Overload settings are application-specific and should be set and/or adjusted by **Qualified Personnel ONLY**.

The **MCP** that is used on the **L1, L2, and L3** input power lines has a **Shunt Trip** feature which may be used to further enhance the system protection function of the **Q7 Flow**. The **Shunt Trip** feature may be connected such that the **L1, L2, and L3 MCP** may be opened by a state change of the **LS** switch. The **LS** switch may be operated by an ancillary circuit or relay. If an ancillary circuit is experiencing a condition which warrants a system shutdown (i.e., door is opened), the **L1, L2, and L3 MCP** will be opened by closing the **Shunt Trip** circuit. During normal operation the **Shunt Trip** circuit is open.

Read and understand all safety warnings before operating this equipment!

MCP Adjustment and Setting

CAUTION

The trip threshold of the **MCP** is set to the lowest setting when the product ships from the factory. Refer to NEC Table 430-152 for recommendations and guidelines on establishing the proper **MCP** setting for a given application. With the vast number of application system variables, the **MCP** may have to be set as a reference, tested, and adjusted up or down until the desired result is achieved.

When using a **Design E** motor, the setting for the instantaneous trip circuit breaker shall not be more than 1100% of the full-load input current. The maximum setting for a motor, other than **Design E**, shall be 800% of the input current. This is done to ensure that the protection does not activate while starting the motor, but is able to provide adequate protection for a fault condition.

Overload settings are application-specific and should be set and/or adjusted by **Qualified Personnel ONLY** (see Qualified Personnel on pg. 3).

Figure 9. MCP Adjustment.

Set to minimum at the factory. Application-specific adjustment is required.



OCP Adjustment and Setting

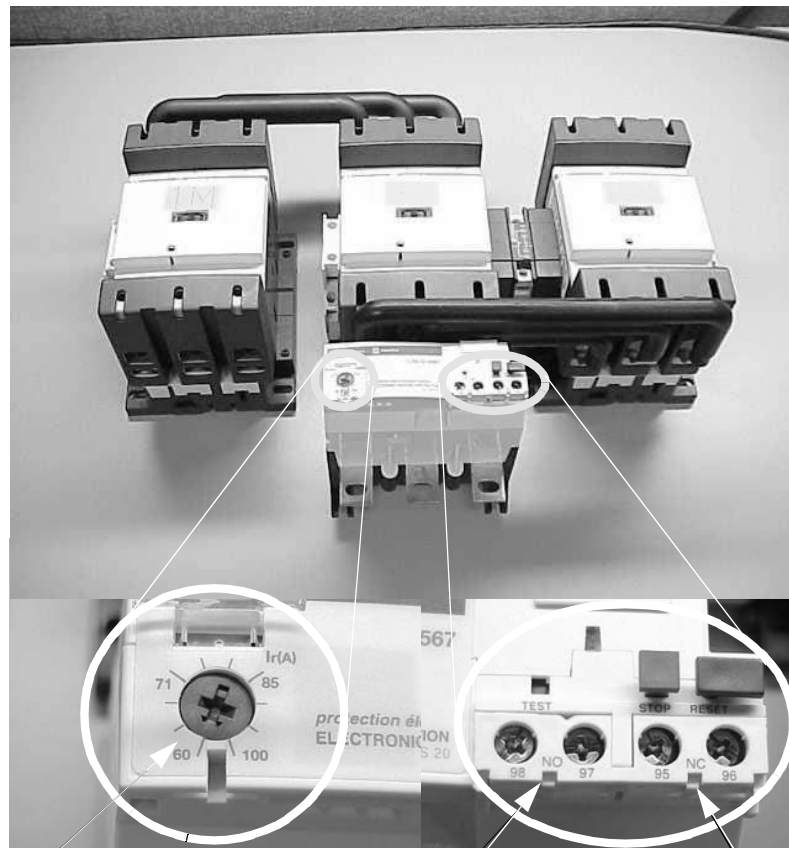
CAUTION

The trip threshold of the **OCP** is set to the lowest setting when the product ships from the factory. The **OCP** setting should allow for the high inrush current of startup and the short-time overload current of high-inertia loads and not be set so high as to provide inadequate overcurrent protection. The **OCP** should be set to a level that is just above the maximum level of the application's normal operating requirements.

For large motor applications, a motor starter is recommended.

Overload settings are application-specific and should be set and/or adjusted by **Qualified Personnel ONLY** (see Qualified Personnel on pg. 3).

Figure 10. Motor OCP Adjustment and OCP Contactor.



Set to minimum at the factory.
Application-specific adjustment is required.

The Normally Open (NO) and the Normally Closed (NC) contacts remain in their normal states during normal operation. Both contacts change states during an overload trip.

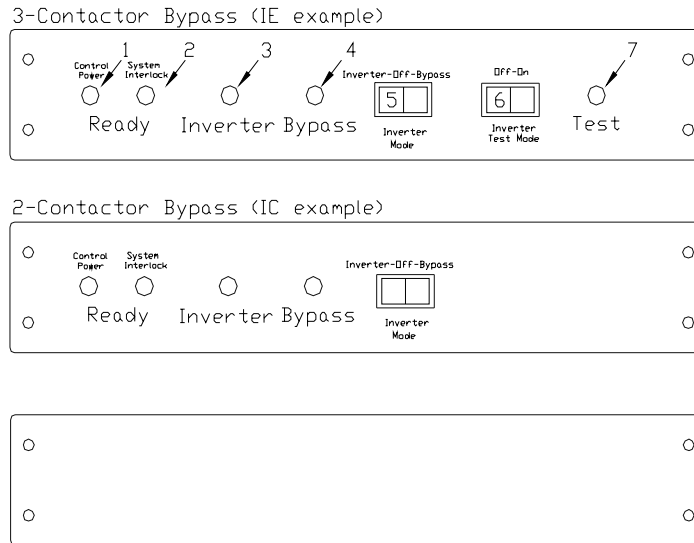
The contacts may be used with ancillary circuitry to annunciate an overload trip or to control other system features.

Q7 Flow Control Panel Features

There are three types of **Q7 Flow** control panels available. The panel used will be a function of the system features available for a given system. Two of the panels provide the user with control and monitoring features and one is used as a cover for an unused panel mounting hole and has no active features.

Figure 11 shows the three **Q7 Flow** panel types followed by a description of the applicable features of each.

Figure 11. Available Q7 Panels.



Panel Items

1. **Control Power** LED (LED 5) — On when the control circuit power is available. This is not an indication that power is off.
2. **System Interlock** LED (LED 4) — On when the following conditions are met:
 - **Control Power** is applied,
 - Door switch (LS) is closed,
 - **Protective Overload** contactor (OL) is closed,
 - **Customer Interface** contact (CI) is closed, and
 - The damper is fully open (**DRA** connected to **DRB**).
3. **Inverter** LED (LED 2) — On when the following conditions are met:
 - **Control Power** is applied,
 - Door switch (LS) is closed,
 - **Protective Overload** contactor (OL) is closed,
 - **Customer Interface** contact (CI) is closed, and
 - The **Inverter Mode** switch is switched to **INV**.

This closes the **1M** and **2M** contactors allowing for normal ASD operation.

4. **Bypass LED (LED 3)** — On when the following conditions are met:
 - **Control Power** is applied,
 - Door switch (LS) is closed,
 - **Protective Overload** contactor (OL) is closed,
 - **Customer Interface** contact (CI) is closed,
 - The damper is fully open (**DRA** connected to **DRB**), and
 - The **Inverter Mode** switch is switched to **BYP**.

This opens the **2M** contactor and closes the **3M** contactor.

5. **Inverter Mode Switch** — With the **System Interlock LED** criteria being met, the **Inverter Mode** switch allows the user to switch the system to the **Inverter Mode**, the **Bypass Mode**, or **Off**.
6. **Inverter Test Mode Switch** — With the **CPT** input power applied and the door closed, the **Inverter Test Mode** switch closes the **1M** contactor (via **K1**) to test the ASD section of the system without providing an output to the connected motor.
7. **Test LED (LED 1)** — On during **Test Mode** operation.

Q7 Flow Theory of Operation

The following explanation targets the Q7 Flow IE configuration. System operation for the Q7 Flow IA and IC configurations differ where the referenced function is not supported by the IA or IC typeform.

Note: Reference Figure 3. on pg. 19 and Figure 12 on pg. 33 for the following explanation.

Initially all switches are open and the normal states of all relays are as indicated in Figure 12 on pg. 33.

Stage 1 Function

Power is applied to stage one via the **Control Power Transformer (CPT)**. The 120 VAC signal is applied to the **Shunt Trip** circuit and **LED 5** (Control Power). If the **LS** switch is open, the **Shunt Trip** circuit enables the system for normal operation and **LED 5** illuminates.

If the **LS** switch is closed, the MCP is opened and the 3-phase input voltage to the system is terminated. The **LS** switch may be connected to an ancillary circuit that can perform a system shutdown in the event of a system malfunction or an ancillary circuit status change (i.e., door opens, etc.).

Stage 2 Function

Stage two has two operating modes: **Test** operation and **INV** operation (**K2** energized). If the **Test** switch (SW1) is closed or if **K2** is energized via **SW2** (SW2 to INV, OL closed [open = overload], and CIA-to-B closure required), the **K1** relay is energized and the states of the **K1** contacts change. The **1M** contactor energizes which closes the **1M** contacts (see Figure 3. on pg. 19; 3-phase input is applied to the ASD).

Stage 3 Function

The closures of the **OL** contacts and the **CIA/B** contacts are required to provide 120 VAC to stage 3.

The three positions of **SW2**; **Off**, **INV**, and **BYP**, are described below.

Off — **K2** and **K3** remain in the normal state.

INV — Energizes **K2** which turns off **LED 1** (Test; if on), illuminates **LED 2** (INV Mode), opens **K2** at stage 3, closes **K2** at stage 4, and completes the **ST** terminal path via PCB 11. The resulting closure of **K2** at stage 4 energizes the **2M** contactor (jumper or open-damper signal at DRA/B required) which allows the ASD output to be applied to the motor (see 2M at Figure 3. on pg. 19).

BYP — Energizes **K3** which turns off **LED 2** (INV Mode) (if on), illuminates **LED 3** (Bypass Mode), opens **K2** at stage 4 (which opens 2M if closed), and closes **K3** at stage 4. The resulting closure of **K3** at stage 4 energizes the **3M** contactor (jumper or open-damper signal at DRA/B required) which allows the utility power to be applied directly to the motor bypassing the ASD (see 3M at Figure 3. on pg. 19).

Note: Ensure that the phase relationship of the **L1**, **L2**, and **L3** connections to the motor for the **Bypass** mode of operation and for the ASD-driven operation are consistent. The **Reverse** and **Forward** functions will be reversed if not properly connected (see diagram in Figure 3. on pg. 19).

The **Damper Response** feedback circuit (DRA/B) may be used to prevent a motor from attempting to force air flow through a duct that has a closed damper.

Damper motor power (120 VAC) is provided from an external source and is applied via the **DSA/DSB** circuit. The 120 VAC is switched via the **OUT1** contacts in the **INV** mode or the **K3** contacts in the **Bypass** mode.

In the **INV** mode the **OUT1** closure occurs upon receiving a **Run** command and applies power to the damper motor. Once the damper-mounted **DRA-to-DRB** contacts are closed (fully open damper required), **K4** is energized. **LED 4** (System Interlock) illuminates and the **K4** contacts close the **S3-to-**

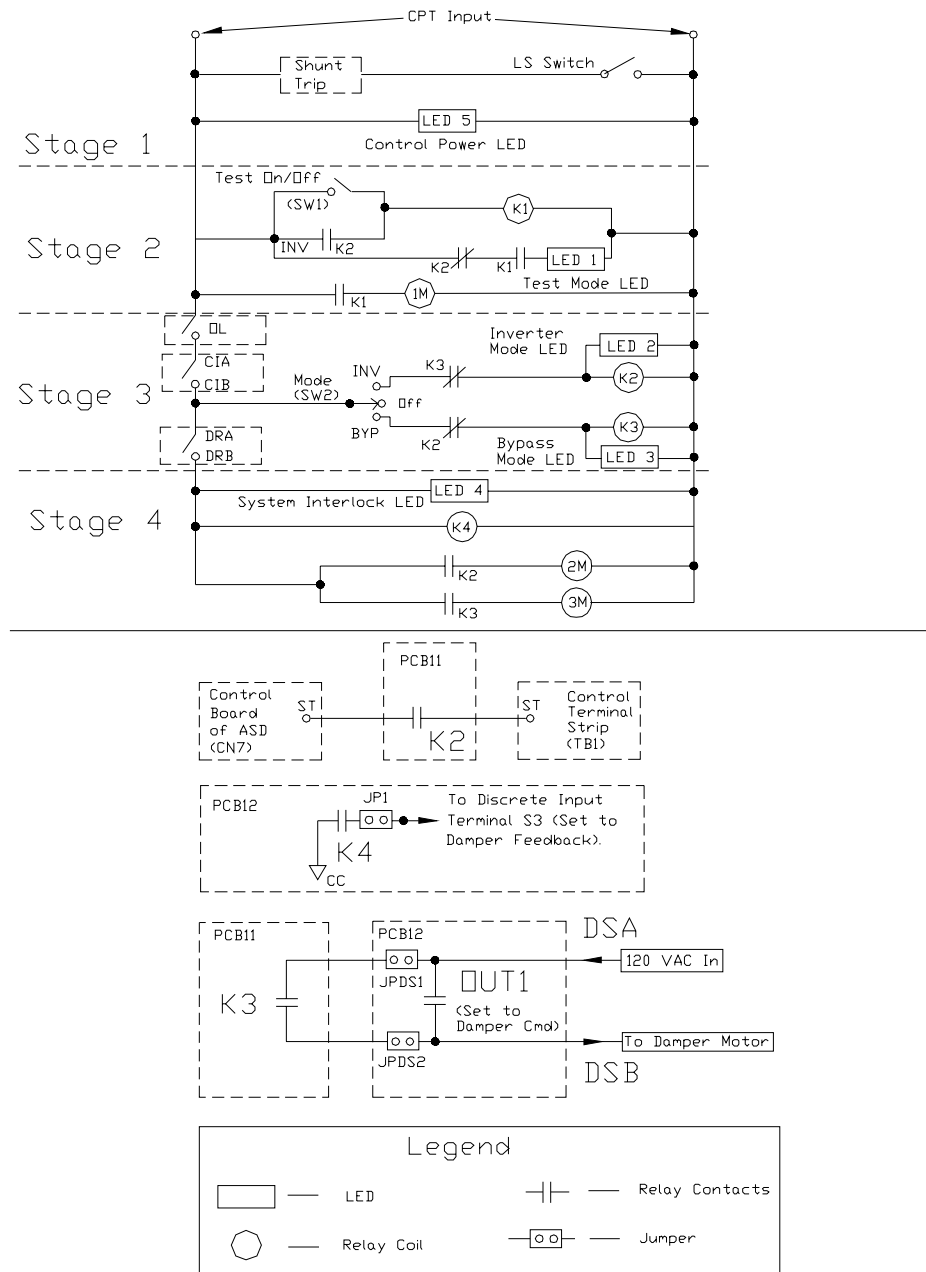
CC connection completing the **Damper Feedback** requirement for ASD operation. The **DRA-to-DRB** closure also provides power to the **2M** coil allowing for the ASD output to be applied to the motor.

Switching **SW2** to the **Bypass** operating mode (jumpers JPDS1 and JPDS2 are required) energizes **K3**. The **K3** contact closure (at PCB11) applies power to the damper motor. Once the damper-mounted **DRA-to-DRB** contacts are closed (fully open damper required), the **3M** coil is energized providing utility power to the motor.

The **DRA-to-DRB** contacts are provided via a reversible limit switch mounted on the damper. The switch terminates power to the damper motor once the damper is fully open or fully closed (reversible means that only the opposite function is available once reaching the fully open or fully closed position).

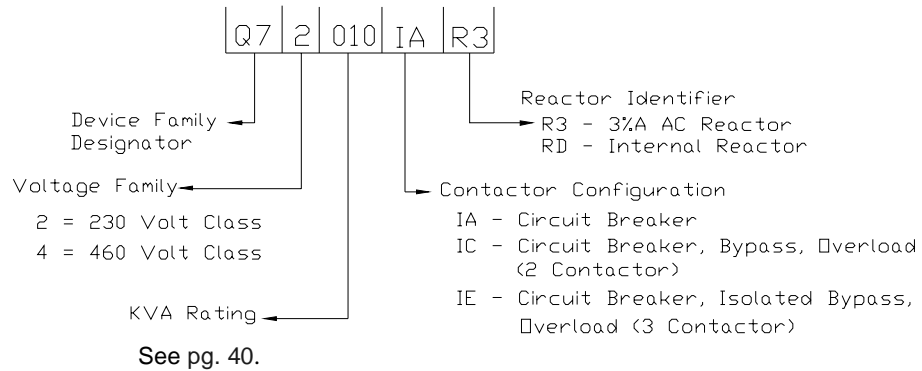
Only a fully opened damper provides the **DRA-to-DRB** connection that is required for normal system operation in either mode.

Figure 12. Simplified depiction of the Q7 Flow Bypass operation.



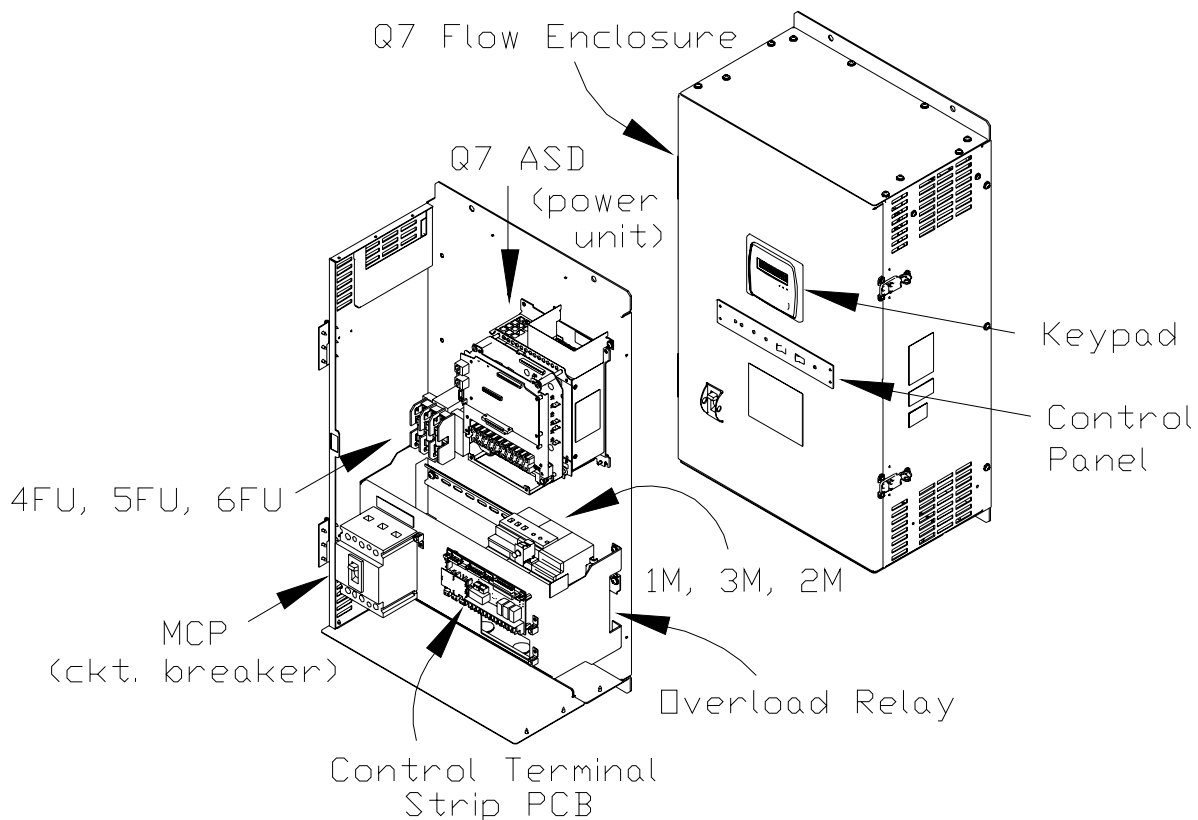
Enclosure Dimensional Information and Weights

Q7 Flow Part Numbering Convention.



Note: The Type 1 enclosed versions of the **Q7 Flow** meet or exceed the specification **UL 1995, the Standard for Heating and Cooling Equipment**, and complies with the applicable requirements for installation in a compartment handling conditioned air.

Figure 13. Q7 Flow Enclosure components.



Enclosure Dimensions/Weights

Table 2. Q7 Flow Series Enclosure Size 1.

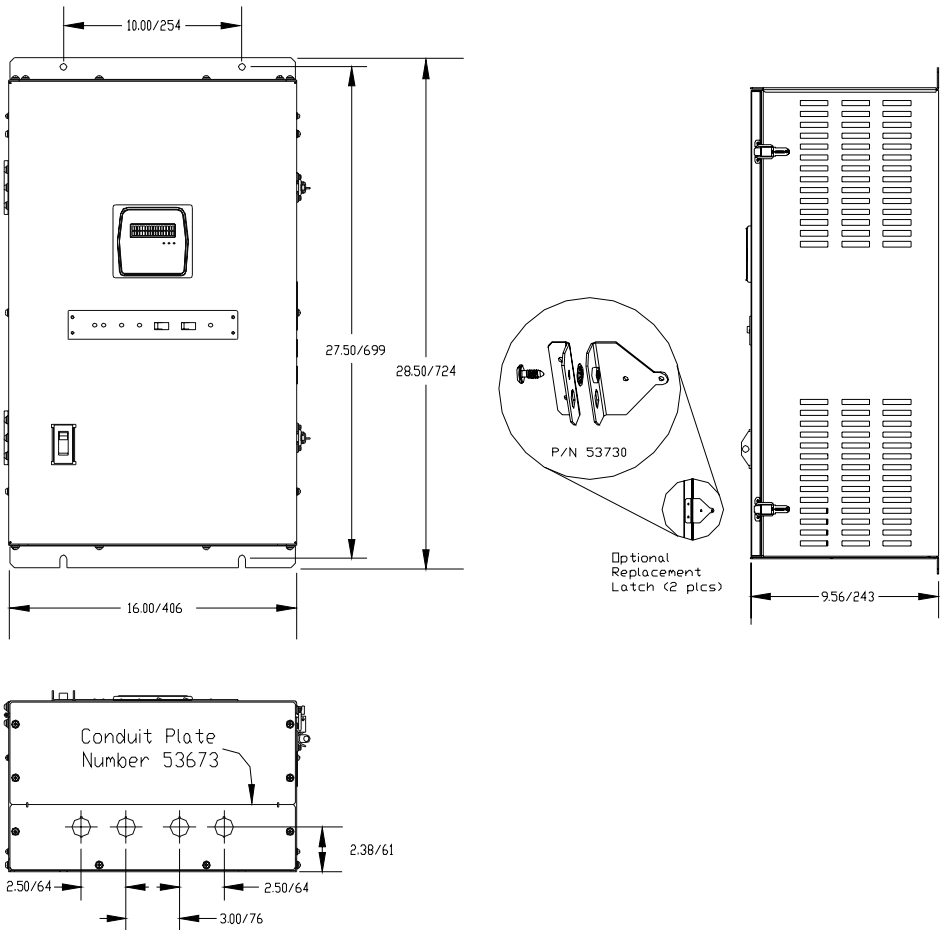
Model Number Q7	Shipping Weight Max. (Lbs.)		
2010B	72	 <p>The technical drawing includes the following dimensions and details:</p> <ul style="list-style-type: none"> Top width: 10.00/254 Front panel width: 16.00/406 Front panel height: 27.50/699 Total height: 28.50/724 Bottom width: 16.00/406 Side panel width: 9.56/243 Detail view: P/N 53730 (Optional Replacement Latch (2 pcs)) Conduit Plate Number 53673 Conduit plate width: 3.00/76 Conduit plate height: 2.38/61 Conduit plate hole spacing: 2.50/64 	
2015B			
2025B			
2035B			
2055B			
2080B			
4015B			
4025B			
4035B			
4055B			
4080B			
4110B			
4160B			

Table 3. Q7 Flow Series Enclosure Size 2.

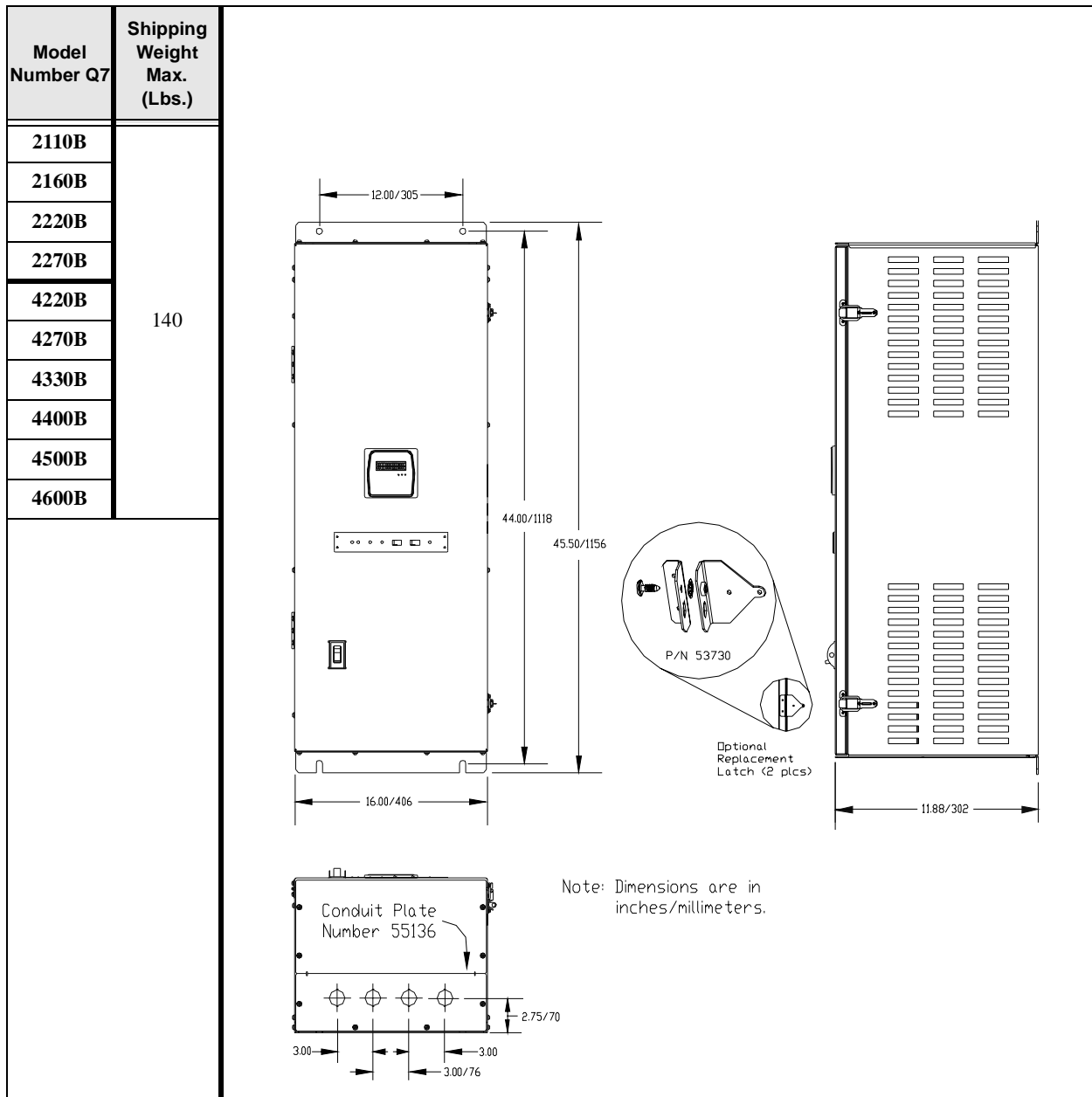
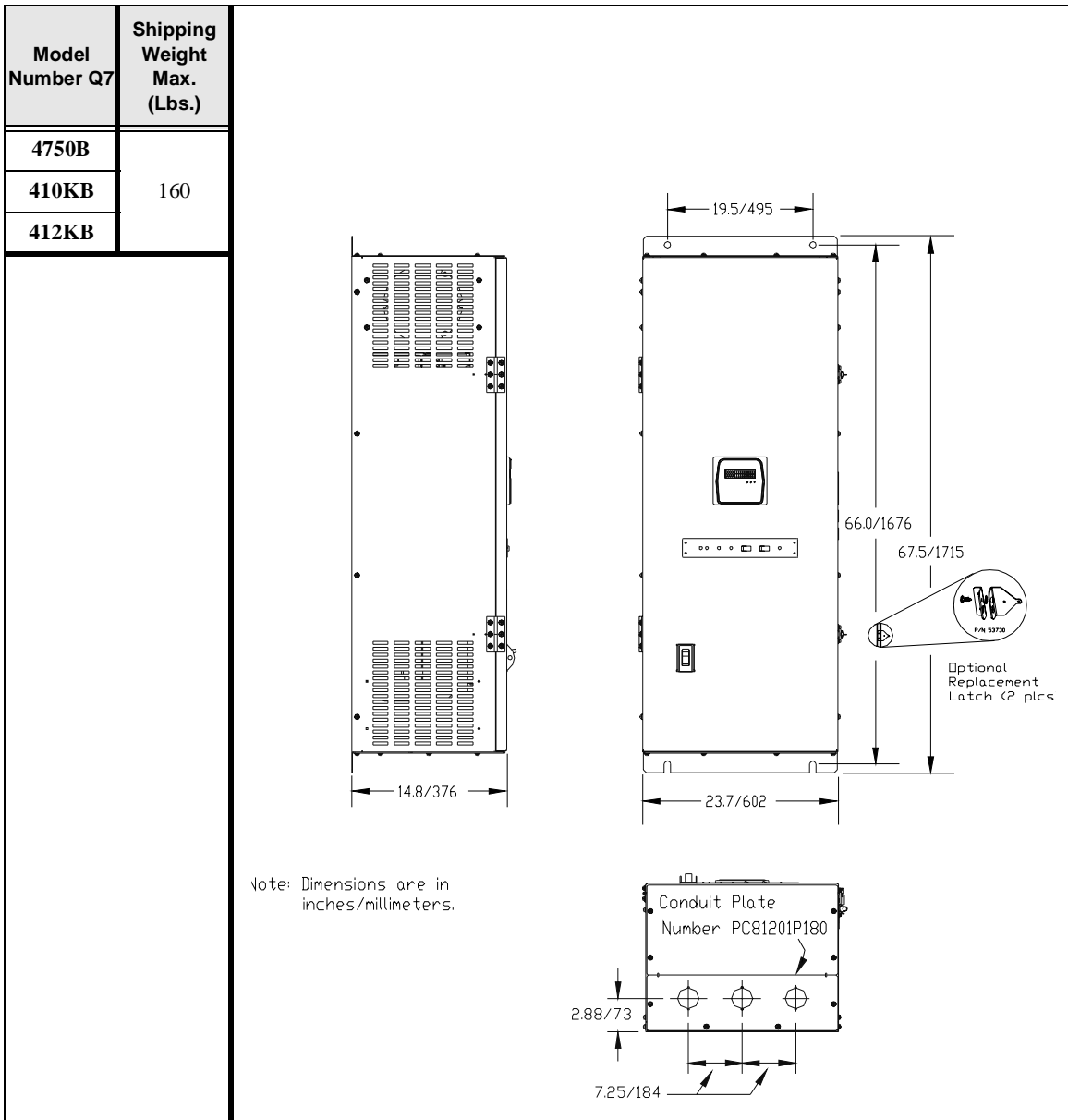


Table 4. Q7 Flow Series Enclosure Size 3.



Cable/Terminal Specifications

The following ratings are guidelines and shall not be the sole determining factor of the lug or wire size used with the **Q7 Flow**. Application-specific variables, wire insulation type, and conductor material are but a few of the considerations when selecting the actual lug and wire type to be used with the **Q7 Flow**.

As a minimum, the installation of the ASD shall conform to the requirements of the **2002 NEC Article 110** and **Article 430**, the **Occupational Safety and Health Administration** requirements, and to any other local and regional industry codes and standards.

Note: Use only 75° C copper wire/cable for motor and power connections.

Table 5. Q7 Flow 230 Volt Drive Cable/Terminal Specifications.

Model No. Q7	MCP Rating (Amps)	Typical Wire/Cable Size			Lug Size/Wire Capacity			
		Input/Output Power	AM, FM, and II Terminals	Control Terminal Strip	Input	OL Relay Output	ASD Output	
2010B	15	14	20 (3-core shield)	18 (2-core shield)	14 – 1/0	18 – 8	24 – 8	
2015B	15	14						
2025B	15	14						
2035B	20	14						
2055B	30	10						
2080B	50	8						
2110B	75	8						
2160B	75	6						
2220B	100	4			TBD	TBD	6 – 4	18 – 4
2270B	125	3						
2330B	150	2						
2400B	200	2/0						
2500B	250	3/0						
2600B	300	250 – *1/0						
2750B	400	*3/0						
210KB	500	*250						
212KB	600	*350	*1/0 – 500					
215KB	700	*400						

Note: Wire size in AWG or kcmil.

Note: (*) Indicates that the item is one of a set of two parallel cables.

Note: TBD ⇒ Contact Toshiba Customer Support Center.

Table 6. Q7 Flow 460 Volt Drive Cable/Terminal Specifications.

Model No. Q7	MCP Rating (Amps)	Typical Wire/Cable Size			Lug Size/Wire Capacity			
		Input/Output Power Wire Size	AM, FM, and II Terminals	Control Terminal Strip	Input	OL Relay Output	ASD Output	
4015B	15	14	20 (3-core shield)	18 (2-core shield)	14 – 1/0	18 – 8	24 – 8	
4025B	15	14						
4035B	15	14						
4055B	15	14						
4080B	30	14						
4110B	30	12						
4160B	30	10						
4220B	50	8						
4270B	75	8						
4330B	75	6						
4400B	100	6						
4500B	100	4						
4600B	125	3						
4750B	150	1			4 – 350	6 – 3/0	10 – 1/0	
410KB	200	2/0			4 – 350	6 – 3/0	12 – 4/0	
412KB	250	3/0			4 – 350	6 – 3/0		
415KB	300	250 – *1/0			TBD	TBD	TBD	* (6 – 250)
420KB	400	*3/0						
425KB	500	*250						
430KB	600	*350						
435KB	700	*500						
440KB	700	*500						
								* (1/0 – 500)

Note: Wire size in AWG or kcmil.

Note: (*) Indicates that the item is one of a set of two parallel cables.
(**) Indicates that the item is one of a set of three parallel cables.

Note: TBD ⇒ Contact Toshiba Customer Support Center.

Current/Voltage Specifications

Table 7. 230 Volt NEMA Type-1 Chassis standard ratings table.

Model No. Q7	Rated KVA	Motor HP/Kw	Input Voltage 3-Ph 50/60 ± 2 Hz	Output Voltage 3-Ph Variable Frequency	Output Current 100% Continuous	Overload Current 110% for 60 Secs.
2010B	1.0	0.75/0.56	200 – 240 VAC (±10%)	Input Voltage Level (Max.)	3.7 A	4.1 A
2015B	1.5	1.0/0.75			4.8 A	5.3 A
2025B	2.5	2.0/1.5			7.8 A	8.6 A
2035B	3.5	3.0/2.2			11.0 A	12.1 A
2055B	5.5	5.0/3.7			17.5 A	19.3 A
2080B	8.0	7.5/5.6			25.3 A	27.8 A
2110B	11.0	10.0/7.5			32.2 A	35.4 A
2160B	16.0	15.0/11.2			48.3 A	53.1 A
2220B	22.0	20.0/14.9			62.1 A	68.3 A
2270B	27.0	25.0/18.5			78.2 A	86.0 A
2330B	33.0	30.0/22.0			92.0 A	101.2 A
2400B	40.0	40.0/30.0			130.0 A	143.0 A
2500B	50.0	50.0/37.3			156.0 A	171.6 A
2600B	60.0	60.0/44.7			192.0 A	211.2A
2750B	75.0	75.0/56.0			248.0 A	272.8 A
210KB	100	100.0/74.6			312.0 A	343.2 A
212KB	125	125.0/93.2			370.0 A	407.0 A
215KB	150	150.0/112.0	415.0 A	456.5 A		

Table 8. 460 Volt NEMA Type-1 Chassis standard ratings table.

Model No. Q7	Rated KVA	Motor HP/Kw	Input Voltage 3-Ph 50/60 ± 2 Hz	Output Voltage 3-Ph Variable Frequency	Output Current 100% Continuous	Overload Current 110% for 60 Secs.
4015B	1.5	1.0/0.75	380 – 480 VAC (±10%)	Input Voltage Level (Max.)	2.6 A	2.9 A
4025B	2.5	2.0/1.5			3.4 A	3.7 A
4035B	3.5	3.0/2.2			4.8 A	5.3 A
4055B	5.5	5.0/3.7			7.6 A	8.4 A
4080B	8.0	7.5/5.6			11.0 A	12.1 A
4110B	11.0	10.0/7.5			14.0 A	15.4 A
4160B	16.0	15.0/11.2			21.0 A	23.1 A
4220B	22.0	20.0/14.9			27.0 A	29.7 A
4270B	27.0	25.0/18.5			34.0 A	37.4 A
4330B	33.0	30.0/22.0			42.0 A	46.2 A
4400B	40.0	40.0/30.0			52.0 A	57.2 A
4500B	50.0	50.0/37.0			65.0 A	71.5 A
4600B	60.0	60.0/45.0			77.0 A	84.7 A
4750B	75.0	75.0/55.0			96.0 A	105.6 A
410KB	100	100/75.0			124.0 A	136.4 A
412KB	125	125/90.0			156.0 A	171.6 A
415KB	150	150/110			190.0 A	209.0 A
420KB	200	200/150			240.0 A	264.0 A
425KB	250	250/185			302.0 A	332.2 A
430KB	300	300/220			370.0 A	407.0 A
435KB	350	350/280	450.0 A	495.0 A		
440KB	400	400/298	492.0 A	541.2 A		

Index

Numerics

1M, 32
 1M contactor, 30
 230 Volt NEMA Type-1 Chassis, 40
 2M, 32
 2M contactor, 30
 3M, 32
 3M contactor, 31
 460 Volt NEMA Type-1 Chassis, 41

A

About This Manual, 2
 AM, 15, 18
 Amps Interrupting Capacity (AIC), 25
 ASD Protection, 25
 ASD-TB1-AC1, 20

B

BYP, 32
 Bypass LED, 31
 Bypass operation, 33

C

Cable/Terminal Specifications, 38
 CC, 15, 18
 CE Compliance Requirements, 9
 CIA to CIB, 11
 CIA/B contacts, 32
 CIA/CIB, 15, 17
 Circuit Breaker Rating, 39
 Connecting the ASD, 13
 Control Panel Features, 30
 Control Power LED, 30
 Control Power Transformer, 32
 Control Terminal Strip, 15
 Control Terminal Strip PCB (P/N 53750), 19
 Current/Voltage Specifications, 40
 Customer Interlock, 11, 15
 Customer Support Center, 2

D

Damper Fdbk, 15
 Damper Feedback, 33
 Damper Feedback (DRA/B circuit), 32
 Damper Response, 15, 32
 Disposal, 4
 DRA, 15
 DRA to DRB, 11
 DRA/DRB, 17

DRA-to-DRB, 32
 DSA/DSB, 18, 32

E

Emergency Off, 15
 Enclosure components, 34
 Enclosure Dimensions, 34
 Enclosure Dimensions/Weight, 35
 Enclosure Size 1, 35
 Enclosure Size 2, 36
 Enclosure Size 3, 37
 Equipment Inspection, 3
 Equipment Warning Labels, 2

F

F, 15, 17
 Filter Selection Table, 10
 Fire Speed, 15
 FLA, 15, 18
 FLB, 15, 18
 FLC, 15, 18
 FM, 15, 18
 Forward, 15
 FP, 15, 18

G

General Safety Information, 1

H

Handling and Storage, 3
 HP/Kw, 40

I

I/O and Control, 15
 II, 15, 18
 Important Notice, 3
 information about the drive, 4
 Input Voltage, 40
 Input/Output terminal names and functions, 15
 Installation, 11
 Installation Notes, 11
 Installation Precautions, 4
 INV, 32
 Inverter LED, 30
 Inverter Mode Switch, 31

L

LS switch, 32
 Lug Size, 38, 39

M

MCP Adjustment and Setting, 28
 MCP Rating, 38
 Mode Switch, 31
 Monitoring/Control Interface, 19
 Motor Protection, 27
 Mounting and Connections, 12
 Mounting the ASD, 12
 MS1 AUX, 25

O

OCP Adjustment and Setting, 29
 Off, 32
 OL contacts, 32
 Operational and Maintenance Precautions, 8
 OUT1, 18
 OUT1A, 15
 OUT2, 18
 OUT2A, 15
 Output Current, 40
 Output Voltage, 40
 Overload Current, 40

P

P24, 15, 18
 Part Numbering Convention, 34
 phase relationship of the L1, L2, and L3 connections, 32
 Power Connections, 13
 PP, 15, 18
 Preset Speed 2, 15

Q

Q7 Flow Connection Diagram, 20
 Q7 Flow Enclosure, 34
 Q7 Flow-IA, 21
 Q7 Flow-IC, 22
 Q7 Flow-IE, 23
 Qualified Personnel, 3

R

R, 15, 17

Rated KVA, 40
 RES, 15, 17
 Reset, 15
 Reverse, 15
 Reverse and Forward functions, 32
 RR, 15, 17
 RX, 15, 18

S

S1, 15, 17
 S2, 15, 17
 S3, 15, 17
 S4, 15, 17
 S4 to CC, 11
 Shipping Weight, 35
 Shunt Trip, 27, 32
 Special Symbols, 2
 ST, 15, 17
 ST to CC, 11
 ST1, 25, 26
 Standby, 15
 Startup and Test, 14
 System Grounding, 13
 System Integration Precautions, 6
 System Interlock LED, 30
 System Protection, 25

T

TB1 Terminals, 19
 Terminal Descriptions, 17
 Terminal Specifications, 38
 Test LED, 31
 Test Mode Switch, 31
 Theory of Operation, 32
 Typical Wire/Cable Size, 38, 39

V

VI, 15, 18
 Voltage Specifications, 40

W

Weights, 34