

TOSHIBA

Leading Innovation >>>

toshiba H9 inverter quick start

H9 ASD Quick Start Guide

Document Number: 58405-003

Date: October, 2009

H9 ASD Quick Start Guide

Document Number: 58405-003

Date: October, 2009



Introduction

Congratulations on the purchase of the new **H9 True Torque Control² Adjustable Speed Drive!**

The **H9 True Torque Control² Adjustable Speed Drive** (ASD) is a solid-state AC drive that features **True Torque Control²**. Toshiba's Vector Control Algorithm enables the motor to develop high starting torque and provide compensation for motor slip, which results in smooth, quick starts and highly efficient operation. The H9 ASD uses digitally-controlled pulse width modulation. The programmable functions may be accessed via the easy-to-use menu or via the Direct Access Number. This feature, combined with Toshiba's high-performance software, delivers unparalleled motor control and reliability.

The H9 ASD is a very powerful tool, yet surprisingly simple to operate. The user-friendly **Electronic Operator Interface** (EOI) of the H9 ASD has an easy-to-read LCD Screen. There is also a read-only LED Screen with enhanced visibility that can be read from a greater distance. The EOI provides easy access to the many monitoring and programming features of the H9 ASD.

The motor control software is menu-driven, which allows for easy access to the motor control parameters and quick changes when required.

To maximize the abilities of your new H9 ASD, a working familiarity with this guide will be required. This guide has been prepared for the ASD installer, user, and maintenance personnel. This guide may also be used as a reference guide or for training. With this in mind, use this guide to develop a system familiarity before attempting to install or operate the device.

For a more in-depth description of the many features of the H9 ASD see the ***H9 ASD Installation and Operation Manual*** included on the CD that was received with the device.

Important Notice

The instructions contained in this guide are not intended to cover all details or variations in equipment types, nor may it provide contingency concerning the installation, operations, or maintenance of this equipment. Should additional information be required contact your Toshiba Sales Representative.

The contents of this guide shall not become a part of or modify any prior or existing agreement, commitment, or relationship. The sales contract contains the entire obligation of Toshiba International Corporation. The warranty contained in the contract between the parties is the sole warranty of Toshiba International Corporation and any statements contained herein do not create new warranties or modify the existing warranty.

Any electrical or mechanical modifications to this equipment without prior written consent of Toshiba International Corporation may void all warranties and may void the UL/CSA listing or other safety certifications. Unauthorized modifications may also result in a safety hazard or equipment damage.

Misuse of this equipment could result in injury and equipment damage. In no event will Toshiba Corporation be responsible or liable for direct, indirect, special, or consequential damage or injury that may result from the misuse of this equipment.

About This Guide

This guide was written by the Toshiba Technical Publications Group. This group is tasked with providing technical documentation for the **H9 Adjustable Speed Drive**. Every effort has been made to provide accurate and concise information to you, our customer.

At Toshiba we are continuously searching for better ways to meet the constantly changing needs of our customers. E-mail your comments, questions, or concerns about this publication to Technical-Publications-Dept@tic.toshiba.com.

Guide's Purpose and Scope

This guide provides information on how to safely install, operate, maintain, and dispose of your **H9 Adjustable Speed Drive**. The information provided in this guide is applicable to the **H9 Adjustable Speed Drive** only.

This guide provides information on the various features and functions of this powerful cost-saving device, including

- Installation,
- System operation,
- Configuration and menu options, and
- Mechanical and electrical specifications.

Included is a section on general safety instructions that describe the warning labels and symbols that are used throughout the guide. Read the guide completely before installing, operating, performing maintenance, or disposing of this equipment.

This guide and the accompanying drawings should be considered a permanent part of the equipment and should be readily available for reference and review. Dimensions shown in the guide are in metric and/or the English equivalent.

Because of our commitment to continuous improvement, Toshiba International Corporation reserves the right, without prior notice, to update information, make product changes, or to discontinue any product or service identified in this publication.

Toshiba International Corporation (TIC) shall not be liable for direct, indirect, special, or consequential damages resulting from the use of the information contained within this manual.

This manual is copyrighted. No part of this manual may be photocopied or reproduced in any form without the prior written consent of Toshiba International Corporation.

© Copyright 2009 Toshiba International Corporation.

TOSHIBA[®] is a registered trademark of the Toshiba Corporation. All other product or trade references appearing in this manual are registered trademarks of their respective owners.

TOSHIBA Leading Innovation[®] is a registered trademark of Toshiba International Corporation.

All rights reserved.

Printed in the U.S.A.

Contacting Toshiba's Customer Support Center

Toshiba's Customer Support Center can be contacted to obtain help in resolving any **Adjustable Speed Drive** system problem that you may experience or to provide application information.

The Support Center is open from 8 a.m. to 5 p.m. (CST), Monday through Friday. The Center's toll free number is US (800) 231-1412/Fax (713) 937-9349 — Canada (800) 527-1204. For after-hours support follow the directions in the outgoing message when calling.

You may also contact Toshiba by writing to:

Toshiba International Corporation

13131 West Little York Road

Houston, Texas 77041-9990

Attn: ASD Product Manager.

For further information on Toshiba's products and services, please visit our website at www.toshiba.com/ind/.

TOSHIBA INTERNATIONAL CORPORATION

H9 Adjustable Speed Drive

Please complete the Warranty Card supplied with the H9 ASD and return it to Toshiba by prepaid mail. This will activate the 12 month warranty from the date of installation; but, shall not exceed 18 months from the shipping date.

Complete the following information and retain for your records.

Model Number: _____

Serial Number: _____

Project Number (if applicable): _____

Date of Installation: _____

Inspected By: _____

Name of Application: _____

Table of Contents

General Safety Information	1
Safety Alert Symbol	1
Signal Words	1
Special Symbols	2
Equipment Warning Labels	2
Qualified Personnel	2
Equipment Inspection	3
Handling and Storage	3
Disposal	3
Installation Precautions	4
Location and Ambient Requirements	4
Mounting Requirements	4
Conductor Routing and Grounding	5
Power Connections	6
Protection	6
System Integration Precautions	7
Personnel Protection	7
System Setup Requirements	8
Operational and Maintenance Precautions	9
Installation and Connections	10
Installation Notes	10
Mounting the ASD	11
Connecting the ASD	12
Lead Length Specifications	16
I/O and Control	17
Electronic Operator Interface	24
EOI Operation	24
EOI Remote Mounting	24
EOI Features	25
System Configuration and Menu Options	29
Root Menus	29
System Operation	58
Initial Setup	58
Startup Wizard Parameters	58
Operation (Local)	61
Default Setting Changes	62
Save User Settings	63

Enclosure Dimensions and Conduit Plate Information	64
Enclosure Dimensions	64
Conduit Plate Dimensions	69
Voltage/Current Specifications	72
Cable/Terminal/Torque Specifications	74
Short Circuit Protection Recommendations	76
Dynamic Braking Resistor Wire/Cable Specifications	77

General Safety Information

DO NOT attempt to install, operate, maintain, or dispose of this equipment until you have read and understood all of the product safety information and directions that are contained in this guide.

Safety Alert Symbol

The **Safety Alert Symbol** is comprised of an equilateral triangle enclosing an exclamation mark. This indicates that a potential personal injury hazard exists.



Signal Words

Listed below are the signal words that are used throughout this guide followed by their descriptions and associated symbols. When the words **DANGER**, **WARNING**, and **CAUTION** are used in this guide they will be followed by important safety information that must be carefully adhered to.

The word **DANGER** preceded by the safety alert symbol indicates that an imminently hazardous situation exists that, if not avoided, will result in serious injury to personnel or loss of life.



The word **WARNING** preceded by the safety alert symbol indicates that a potentially hazardous situation exists that, if not avoided, could result in serious injury to personnel or loss of life.



The word **CAUTION** preceded by the safety alert symbol indicates that a potentially hazardous situation exists that, if not avoided, may result in minor or moderate injury.



The word **CAUTION** without the safety alert symbol indicates a potentially hazardous situation exists that, if not avoided, may result in equipment and property damage.

CAUTION

Special Symbols

To identify special hazards, other symbols may appear in conjunction with the **DANGER**, **WARNING**, and **CAUTION** signal words. These symbols indicate areas that require special and/or strict adherence to the procedures to prevent serious injury to personnel or loss of life.

Electrical Hazard Symbol

A symbol that is comprised of an equilateral triangle enclosing a lightning bolt indicates a hazard of injury from electrical shock or burn.



Explosion Hazard Symbol

A symbol that is comprised of an equilateral triangle enclosing an explosion indicates a hazard of injury from exploding parts.



Equipment Warning Labels

DO NOT attempt to install, operate, perform maintenance, or dispose of this equipment until you have read and understood all of the product labels and user directions that are contained in this guide.

Warning labels that are attached to the equipment will include the exclamation mark within a triangle. **DO NOT** remove or cover any of these labels. If the labels are damaged or if additional labels are required, contact your Toshiba Sales Representative.

Labels attached to the equipment are there to provide useful information or to indicate an imminently hazardous situation that may result in serious injury, severe property and equipment damage, or loss of life if safe procedures or methods are not followed as outlined in this guide.

Qualified Personnel

Installation, operation, and maintenance shall be performed by **Qualified Personnel Only**. A Qualified Person is one that has the skills and knowledge relating to the construction, installation, operation, and maintenance of the electrical equipment and has received safety training on the hazards involved (Refer to the latest edition of NFPA 70E for additional safety requirements).

Qualified Personnel shall:

- Have carefully read the entire guide.
- Be familiar with the construction and function of the H9 ASD, the equipment being driven, and the hazards involved.
- Be able to recognize and properly address hazards associated with the application of motor-driven equipment.
- Be trained and authorized to safely energize, de-energize, ground, lockout/tagout circuits and equipment, and clear faults in accordance with established safety practices.
- Be trained in the proper care and use of protective equipment such as safety shoes, rubber gloves, hard hats, safety glasses, face shields, flash clothing, etc., in accordance with established safety practices.

For further information on workplace safety visit www.osha.gov.

Equipment Inspection

- Upon receipt of the equipment inspect the packaging and equipment for shipping damage.
- Carefully unpack the equipment and check for parts that may have been damaged during shipping, missing parts, or concealed damage. If any discrepancies are discovered, it should be noted with the carrier prior to accepting the shipment, if possible. File a claim with the carrier if necessary and immediately notify your Toshiba Sales Representative.
- Ensure that the rated capacity and the model number specified on the nameplate conform to the order specifications.
- Modification of this equipment is dangerous and is to be performed by factory trained personnel. When modifications are required contact your Toshiba Sales Representative.
- **DO NOT** install the H9 ASD if it is damaged or if it is missing any component(s).
- Inspections may be required after moving equipment.
- Contact your Toshiba Sales Representative to report discrepancies or for assistance if required.

Handling and Storage

- Use proper lifting techniques when moving the H9 ASD; including properly sizing up the load, getting assistance, and using a forklift if required.
- Store in a well-ventilated location and preferably in the original carton if the equipment will not be used upon receipt.
- Store in a cool, clean, and dry location. Avoid storage locations with extreme temperatures, rapid temperature changes, high humidity, moisture, dust, corrosive gases, or metal particles.
- The storage temperature range of the H9 ASD is -13° to 149° F (-25° to 65° C).
- Do not store the unit in places that are exposed to outside weather conditions (i.e., wind, rain, snow, etc.).
- Store in an upright position.

Disposal

Never dispose of electrical components via incineration. Contact your state environmental agency for details on disposal of electrical components and packaging in your area.

Installation Precautions

Location and Ambient Requirements

- The Toshiba H9 ASD is intended for permanent installations only.
- Installation should conform to the **2008 National Electrical Code — Article 110 (NEC)** (*Requirements For Electrical Installations*), all regulations of the **Occupational Safety and Health Administration**, and any other applicable national, regional, or industry codes and standards.
- Select a mounting location that is easily accessible, has adequate personnel working space, and adequate illumination for adjustment, inspection, and maintenance of the equipment (refer to 2008 NEC Article 110-13).
- **DO NOT** mount the H9 ASD in a location that would produce catastrophic results if it were to fall from its mounting location (equipment damage or injury).
- **DO NOT** mount the H9 ASD in a location that would allow it to be exposed to flammable chemicals or gases, water, solvents, or other fluids.
- Avoid installation in areas where vibration, heat, humidity, dust, fibers, metal particles, explosive/corrosive mists or gases, or sources of electrical noise are present.
- The installation location shall not be exposed to direct sunlight.
- Allow proper clearance spaces for installation. Do not obstruct the ventilation openings. Refer to the section titled [Installation and Connections on pg. 10](#) for further information on ventilation requirements.
- The ambient operating temperature range of the H9 ASD is 14° to 104° F (-10° to 40° C).

Mounting Requirements

- Only [Qualified Personnel](#) should install this equipment.
- Install the unit in a secure and upright position in a well-ventilated area.
- As a minimum, the installation of the equipment should conform to the 2008 NEC Article 110 Requirements For Electrical Installations, OSHA, as well as any other applicable national, regional, or industry codes and standards.
- Installation practices should conform to the latest revision of NFPA 70E Electrical Safety Requirements for Employee Workplaces.
- It is the responsibility of the ASD installer/maintenance personnel to ensure that the unit is installed in an enclosure that will protect personnel against electric shock.

Conductor Routing and Grounding



- Use separate metal conduits for routing the input power, output power, and control circuit.
- A separate ground cable should be run inside the conduit with the input power, output power, and control circuits.
- **DO NOT** connect **CC** to earth ground.
- Use **IIC** terminal as the return for the **VI/II** (V/I) input.
- Always ground the unit to prevent electrical shock and to help reduce electrical noise.
- It is the responsibility of the ASD installer/maintenance personnel to provide proper grounding and branch circuit protection in accordance with the **2008 NEC** and any applicable local codes.

— **The Metal Of Conduit Is Not An Acceptable Ground** —

Grounding Capacitor Switch

The H9 ASD is equipped with leak reduction capacitors which are used to reduce the EMI leakage via the 3-phase power-input circuit and for compliance with the **Electromagnetic Compatibility Directive** (EMC).

The effective value of the capacitor may be increased, reduced, or removed entirely via the **Selector Switch, Switching Bar**, or the **Switching Screw** — the type used is typeform-specific.

The **Grounding Capacitor Switch** allows the user to quickly change the value of the leakage-reduction capacitance of the 3-phase input circuit without the use of tools.

See the section titled [Power Connection Requirements on pg. 13](#) for more on the [Grounding Capacitor](#).

See figures 4, 5, 6, and 7 on [pg. 15](#) for an electrical depiction of the leakage-reduction functionality of the [Grounding Capacitor](#) and the methods used to set the capacitance value.

Power Connections



Contact With Energized Wiring Will Cause Severe Injury Or Loss Of Life.

- Turn off, lockout, and tag out all power sources before connecting the power wiring to the equipment.
- After ensuring that all power sources are turned off and isolated in accordance with established lockout/tag out procedures, connect the 3-phase power source wiring of the correct voltage to the correct input terminals and connect the output terminals to a motor of the correct voltage and type for the application (refer to NEC Article 300 – Wiring Methods and Article 310 – Conductors For General Wiring). Size the branch circuit conductors in accordance with NEC Table 310.16.
- If multiple conductors that are smaller than the recommended sizes are used in parallel for the input or output power, each branch of the parallel set shall have its own conduit and not share its conduit with other parallel sets (i.e., place U1, V1, and W1 in one conduit and U2, V2, and W2 in another; refer to NEC Article 300.20 and Article 310.4). National and local electrical codes should be referenced if three or more power conductors are run in the same conduit (refer to 2008 NEC Article 310 adjustment factors on page 70-142).
- Ensure that the 3-phase input power is **NOT** connected to the output of the H9 ASD. This will damage the H9 ASD and may cause injury to personnel.
- **DO NOT** connect resistors across terminals PA – PC or PO – PC. This may cause a fire.
- Ensure the correct phase sequence and the desired direction of motor rotation in the **Bypass** mode (if applicable).
- Turn the power on only after attaching and/or securing the front cover.

Protection

- Ensure that primary protection exists for the input wiring to the equipment. This protection must be able to interrupt the available fault current from the power line. The equipment may or may not be equipped with an input disconnect (option).
- All cable entry openings must be sealed to reduce the risk of entry by vermin and to allow for maximum cooling efficiency.
- External dynamic braking resistors must be thermally protected.
- It is the responsibility of the ASD installer/maintenance personnel to setup the **Emergency Off** braking system of the H9 ASD. The function of the **Emergency Off** braking function is to remove output power from the drive in the event of an emergency. A supplemental braking system may also be engaged in the event of an emergency. For further information on braking systems, see parameters **F250** and **F304**.

***Note:** A supplemental emergency stopping system should be used with the H9 ASD. Emergency stopping should not be a task of the H9 ASD alone.*

- Follow all warnings and precautions and do not exceed equipment ratings.

System Integration Precautions

The following precautions are provided as general guidelines for the setup of the H9 ASD within the system.

- The Toshiba H9 ASD is a general-purpose product. It is a system component only and the system design should take this into consideration. Please contact your Toshiba Sales Representative for application-specific information or for training support.
- The Toshiba H9 ASD is part of a larger system and the safe operation of the H9 ASD will depend upon observing certain precautions and performing proper system integration.
- Improperly designed or improperly installed system interlocks may render the motor unable to start or stop on command.
- The failure of external or ancillary components may cause intermittent system operation (i.e., the system may start the motor without warning).
- A detailed system analysis and job safety analysis should be performed by the systems designer and/or systems integrator before the installation of the H9 ASD component. Contact your Toshiba Sales Representative for options availability and for application-specific system integration information if required.

Personnel Protection

- Installation, operation, and maintenance shall be performed by **Qualified Personnel Only**.
- A thorough understanding of the H9 ASD will be required before the installation, operation, or maintenance of the H9 ASD.



- Rotating machinery and live conductors can be hazardous and shall not come into contact with personnel. Personnel should be protected from all rotating machinery and electrical hazards at all times.
- Insulators, machine guards, and electrical safeguards may fail or be defeated by the purposeful or inadvertent actions of workers. Insulators, machine guards, and electrical safeguards are to be inspected (and tested where possible) at installation and periodically after installation for potential hazardous conditions.
- **DO NOT** allow personnel near rotating machinery. Warning signs to this effect shall be posted at or near the machinery.
- **DO NOT** allow personnel near electrical conductors. Contact with electrical conductors can be fatal. Warning signs to this effect shall be posted at or near the hazard.
- Personal protection equipment shall be provided and used to protect employees from any hazards inherent to system operation.

System Setup Requirements

- When using the H9 ASD as an integral part of a larger system, it is the responsibility of the H9 ASD installer/maintenance Personnel to ensure that there is a fail-safe in place (i.e., an arrangement designed to switch the system to a safe condition if there is a fault or failure).
- System safety features should be employed and designed into the integrated system in a manner such that system operation, even in the event of system failure, will not cause harm or result in system damage or injury to personnel (i.e., E-Off, Auto-Restart settings, System Interlocks, etc.).
- The programming setup and system configuration of the H9 ASD may allow it to start the motor unexpectedly. A familiarity with the Auto-Restart settings are a requirement to use this product.
- Power factor improvement capacitors or surge absorbers **MUST NOT** be installed on the output of the H9 ASD.
- Use of the built-in system protective features is highly recommended (i.e., E-Off, Overload Protection, etc.).
- The operating controls and system status indicators should be clearly readable and positioned where the operator can see them without obstruction.
- Additional warnings and notifications shall be posted at the equipment installation location as deemed required by [Qualified Personnel](#).



CAUTION

- There may be thermal or physical properties, or ancillary devices integrated into the overall system that may allow for the H9 ASD to start the motor without warning. Signs to this effect must be posted at the equipment installation location.
- If a secondary magnetic contactor (MC) or an ASD output disconnect is used between the H9 ASD and the load, it should be interlocked to halt the H9 ASD before the secondary contact opens. If the output contactor is used for bypass operation, it must be interlocked such that commercial power is never applied to the H9 ASD output terminals (U, V, or W).
- When using an ASD output disconnect, the ASD and the motor must be stopped before the disconnect is either opened or closed. Closing the output disconnect while the 3-phase output of the ASD is active may result in equipment damage or injury to personnel.

Operational and Maintenance Precautions



- Turn off, lockout, and tag out the main power, the control power, and instrumentation connections before inspecting or servicing the drive, opening the door of the enclosure, or connecting/disconnecting the power wiring to the equipment.
- Turn off, lockout, and tag out the main power, the control power, and instrumentation connections before proceeding to disconnect or connect the power wiring to the equipment.
- The capacitors of the H9 ASD maintain a residual charge for a period of time after turning the ASD off. The required time for each ASD typeform is indicated with a cabinet label and a **Charge LED** (shown for smaller ASDs in [Figure 2 on pg. 12](#); LED is located on the front panel of larger ASDs). Wait at least the minimum time indicated on the enclosure-mounted label and ensure that the **Charge LED** has gone out before opening the door of the ASD once the ASD power has been turned off.
- Turn the power on only after attaching (or closing) the front cover and **DO NOT** remove or open the front cover of the H9 ASD when the power is on.
- **DO NOT** attempt to disassemble, modify, or repair the H9 ASD. Call your Toshiba Sales Representative for repair information.
- **DO NOT** place any objects inside of the H9 ASD.
- If the H9 ASD should emit smoke, or an unusual odor or sound, turn the power off immediately.
- The heat sink and other components may become extremely hot to the touch. Allow the unit to cool before coming in contact with these items.
- Remove power from the H9 ASD during extended periods of non-use.
- The system should be inspected periodically for damaged or improperly functioning parts, cleanliness, and to ensure that the connectors are tightened securely.

Installation and Connections

The **H9 True Torque Control² Adjustable Speed Drive** may be set up initially by performing a few simple configuration settings. To operate properly, the ASD must be securely mounted and connected to a power source (3-phase AC input at the R/L1, S/L2, and T/L3 terminals). The control terminals of the H9 ASD may be used by connecting the terminals of the **Terminal Board** to the proper sensors or signal input sources (see the section titled **I/O and Control** on pg. 17 and **Figure 9** on pg. 20).

System performance may be further enhanced by assigning a function to the output terminals of the **Terminal Board** and connecting the terminals to the proper indicators or actuators (LEDs, relays, contactors, etc.).

***Note:** The optional H9 ASD interface boards may be used to expand the I/O functionality of the H9 ASD.*

Installation Notes



CAUTION

When a brake-equipped motor is connected to the H9 ASD, it is possible that the brake may not release at startup because of insufficient voltage. To avoid this, **DO NOT** connect the brake or the brake contactor to the output of the H9 ASD.

If an output contactor is used for bypass operation, it must be interlocked such that commercial power is never applied to the output terminals of the H9 ASD (U/T1, V/T2, and W/T3).

DO NOT apply commercial power to the H9 ASD output terminals **U/T1**, **V/T2**, and **W/T3**.

If a secondary magnetic contactor (MC) is used between the output of the H9 ASD and the motor, it should be interlocked such that the **ST – CC** connection is disconnected before the output contactor is opened.

DO NOT open and then close a secondary magnetic contactor between the H9 ASD and the motor unless the ASD is off and the motor is not rotating.

***Note:** Re-application of power via a secondary contact while the H9 ASD is on or while the motor is still turning may cause ASD damage.*

The H9 ASD input voltage should remain within 10% of the specified input voltage range. Input voltages approaching the lower or upper-limit settings may require that the over-voltage and under-voltage stall protection level parameters be adjusted. Voltages outside of the permissible tolerance should be avoided.

The frequency of the input power should be ± 2 Hz of the specified input frequency.

DO NOT use an ASD with a motor that has a current rating higher than the rated current of the ASD.

The H9 ASD is designed to operate NEMA B motors. Consult with your Toshiba Sales Representative before using the ASD for special applications such as with an explosion-proof motor or applications with a piston load.

Disconnect the H9 ASD from the motor before megging or applying a bypass voltage to the motor.

Interface problems may occur when an ASD is used in conjunction with some types of process controllers. Signal isolation may be required to prevent controller and/or ASD malfunction (contact your Toshiba Sales Representative or the process controller manufacturer for additional information about compatibility and signal isolation).

Use caution when setting the output frequency. Over speeding a motor decreases its ability to deliver torque and may result in damage to the motor and/or the driven equipment.

Not all H9 ASDs are equipped with internal primary power input fuses (HP dependent). When connecting two or more drives that have no internal fuse to the same power line as shown in [Figure 1](#), select a circuit-breaking configuration that will ensure that if a short circuit occurs in ASD 1, only MCCB2 trips, and MCCB1 remains engaged. If it is not feasible to use this configuration, insert a fuse between MCCB2 and ASD 1.

Figure 1. Circuit Breaker Configuration.

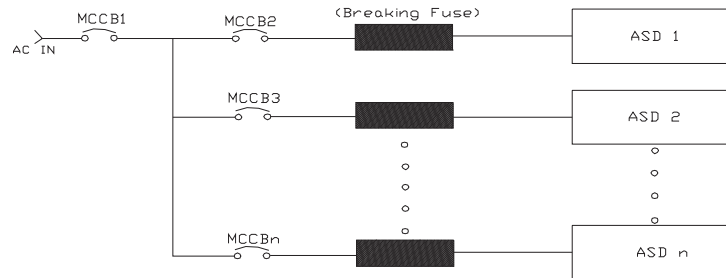

Mounting the ASD

CAUTION

— The following thermal specifications apply to the 230-volt and 460-volt ASDs ONLY —

Install the unit securely in a well ventilated area that is out of direct sunlight.

The process of converting AC to DC, and then back to AC produces heat. During normal ASD operation, up to 5% of the input energy to the ASD may be dissipated as heat. If installing the ASD in a cabinet, ensure that there is adequate ventilation.

DO NOT operate the H9 ASD with the enclosure door open.

The ambient operating temperature rating of the H9 ASD is 14° to 104° F (-10° to 40° C).

When installing adjacent ASDs horizontally Toshiba recommends at least 5 cm of space between adjacent units. However, horizontally mounted ASDs may be installed side-by-side with no space in between the adjacent units — side-by-side installations require that the top cover be removed from each ASD.

For 150 HP and above ASDs, a minimum of 50 cm of space is required above and below adjacent units and any obstruction. This space is the recommended minimum space requirement for the H9 ASD and ensures that adequate ventilation is provided for each unit. More space will provide a better environment for cooling (see the section titled [Enclosure Dimensions and Conduit Plate Information](#) on [pg. 64](#) for additional information on mounting space requirements).

Note: Ensure that the ventilation openings are not obstructed.

Connecting the ASD



Refer to the section titled [Installation Precautions](#) on pg. 4 and the section titled [Lead Length Specifications](#) on pg. 16 before attempting to connect the H9 ASD and the motor to electrical power.

Power Connections



Contact With 3-Phase Input/Output Terminals May Cause An Electrical Shock Resulting In Injury Or Loss Of Life.

See [Figure 20](#) on pg. 22 for a system I/O connectivity schematic.

An inductor (DCL) may be connected across the **PO** and **PA/+** terminals to provide additional filtering. When not used, a jumper must be connected across these terminals (see [Figure 20](#) on pg. 22).

PA/+ and **PB** are used for the DBR connection if using a braking resistor.

PC/- is the negative terminal of the DC bus.

R/L1, **S/L2**, and **T/L3** are the 3-phase input supply terminals for the H9 ASD.

U/T1, **V/T2**, and **W/T3** are the output terminals of the H9 ASD that connect to the motor.

The location of the **Charge LED** for the smaller typeform ASD is provided in [Figure 2](#). The **Charge LED** is located on the front door of the enclosure of the larger ASDs.

Figure 2. Typical H9 ASD Input/output Terminals and the [Grounding Capacitor Switch](#).

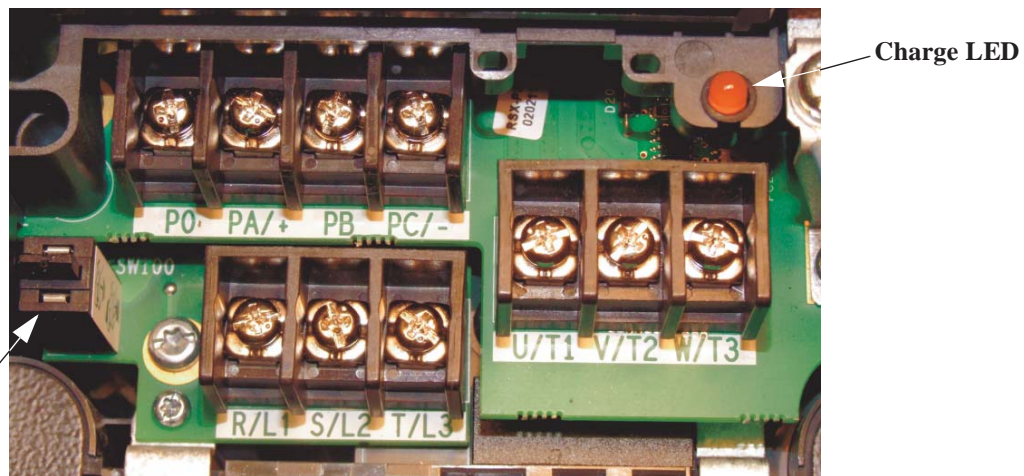

Grounding Capacitor Switch — Pull for **Small** capacitance/push for **Large** capacitance.

Power Connection Requirements

Connect the 3-phase input power to the input terminals of the H9 ASD at **R/L1**, **S/L2**, and **T/L3** (see [Figure 3](#) for the typical electrical connection scheme). Connect the output of the ASD to the motor from the ASD terminals **U/T1**, **V/T2**, and **W/T3**. The input and output conductors and terminal lugs used shall be in accordance with the requirements listed in the section titled [Voltage/Current Specifications](#) on [pg. 72](#).

If multiple conductors are used in parallel for the input or output power and it is necessary to use separate conduits, each parallel set shall have its own conduit and not share its conduit with other parallel sets (i.e., place U1, V1, and W1 in one conduit and U2, V2, and W2 in another; refer to NEC Article 300.20 and Article 310.4). National and local electrical codes should be referenced if three or more power conductors are run in the same conduit (refer to 2008 NEC Article 310 adjustment factors).

Note: *National and local codes should be referenced when running more than three conductors in the same conduit.*

Install a molded case circuit breaker (MCCB) or fuse between the 3-phase power source and the H9 ASD in accordance with the fault current setting of the ASD and **2008 NEC Article 430**.

The H9 ASD is designed and tested to comply with UL Standard 508C. Modifications to the ASD system or failure to comply with the short circuit protection requirements outlined in this manual may disqualify the UL rating. See [Table 9](#) on [pg. 76](#) for typeform-specific short circuit protection recommendations.

As a minimum, the installation of the H9 ASD shall conform to **2008 NEC Article 110**, the **Occupational Safety and Health Administration** requirements, and to any other local and regional industry codes and standards.

Note: *In the event that the motor rotates in the wrong direction when powered up, reverse any two of the three H9 ASD output power leads (U, V, or W) connected to the motor.*

Figure 3. H9 ASD/Motor Typical Connection Diagram.

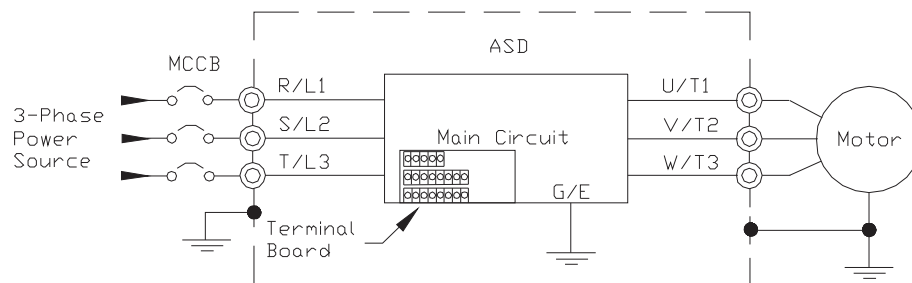

System Grounding

Proper grounding helps to prevent electrical shock and to reduce electrical noise. The H9 ASD is designed to be grounded in accordance with **Article 250** of the **2008 NEC** or **Section 10/Part One** of the **Canadian Electrical Code (CEC)**.

The grounding conductor shall be sized in accordance with **Article 250-122** of the **NEC** or **Part One-Table 6** of the **CEC**.

— The Metal Of Conduit Is Not An Acceptable Ground —

The input, output, and control lines of the system shall be run in separate metal conduits and each shall have its own ground conductor.

ASDs produce high-frequency noise — take steps to avoid the negative effects of noise. Listed below are some examples of measures that will help to combat noise problems during installation.

- **DO NOT** install the input power and output power wires in the same duct or in parallel with each other, and do not bind them together.
- **DO NOT** install the input/output power wires and the wires of the control circuit in the same duct or in parallel with each other, and do not bind them together.
- Use shielded wires or twisted wires for the control circuits.
- Ensure that the grounding terminals (G/E) of the H9 ASD are securely connected to ground.
- Connect a surge suppressor to every electromagnetic contactor and every relay installed near the ASD.
- Install noise filters as required.

Grounding Capacitor

The **Grounding Capacitor** plays a role in minimizing the effects of leakage current through the ASD system and through ground paths to other systems. Leakage current may cause the improper operation of earth-leakage current breakers, leakage-current relays, ground relays, fire alarms, and other sensors — and it may cause superimposed noise on CRT screens.

The **Grounding Capacitor Switch** allows the user to quickly change the value of the leakage-reduction capacitance of the 3-phase input circuit. See figures 4, 5, 6, and 7 on pg. 15 for an electrical depiction of the leakage-reduction functionality and the methods used to change the capacitance value. The method used is typeform-specific.

If using a 460-volt 5 HP ASD or a 460-volt ASD that is in the range of 7.5 HP to 25 HP, and the **U/T1**, **V/T2**, and **W/T3** connections to the motor are 100 meters or more in length, the ASD **Carrier Frequency** must be set to 4 kHz or less when activating or deactivating the **Grounding Capacitor Switch**. ASD overheating may occur if the **Carrier Frequency** is set above 4 kHz when activating or deactivating the **Grounding Capacitor Switch**.

See pg. 5 for more information on the **Grounding Capacitor Switch** and pg. 12 for the location.

Figure 4. The **Grounding Capacitor**

Switch is used on typeforms **230-volt** 0.5 HP to 10 HP and the 25 and 30 HP/**460-volt** 1.0 HP to 250 HP.

The value may be set to **Maximum** (default setting) or to **Zero** by pushing or pulling the switch actuator, respectively.

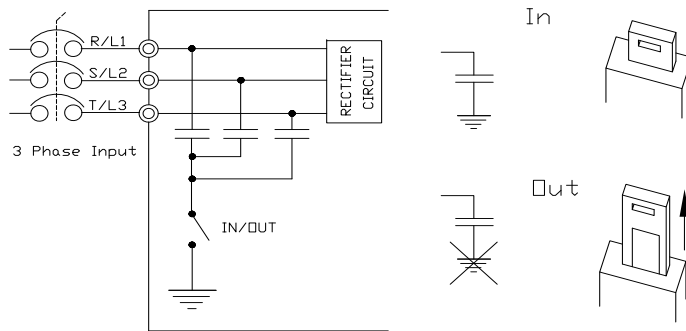

Figure 5. The **Grounding Capacitor**

Switch is used on typeforms **230-volt** 15 HP to 20 HP and the 40 HP to 60 HP/**460-volt** 30 HP to 100 HP.

The value may be set to **Large** (default setting) or **Small** by pushing or pulling the switch actuator, respectively.

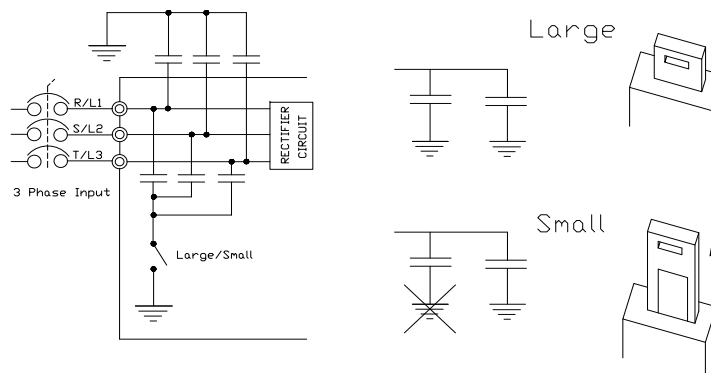

Figure 6. The **Grounding Capacitor**

Bar is used on typeforms **230-volt** 75 HP and the 100 HP/**460-volt** 125 HP and the 150 HP.

The value may be set to **Large** or **Small** (default setting) by connecting or disconnecting the switching bar, respectively.

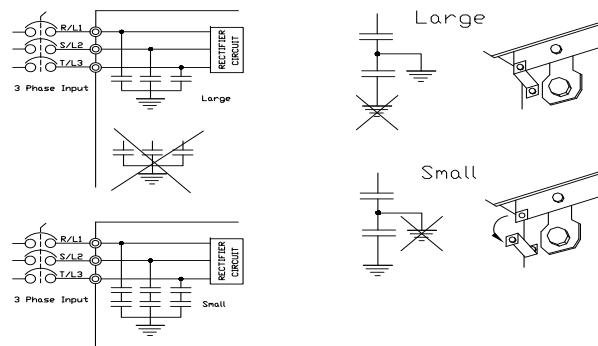
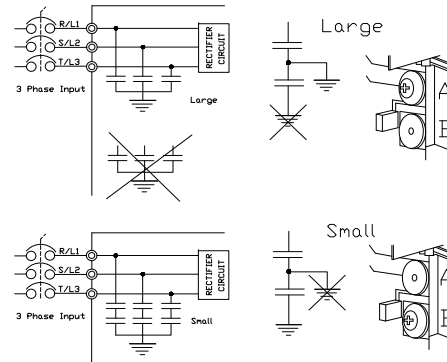

Figure 7. The **Grounding Capacitor**

Screw is used on typeforms **460-volt** 175 HP and above.

The value may be set to **Large** or **Small** (default setting) by placing the screw in the **A** position or by placing the screw in the **B** position, respectively.



Lead Length Specifications

Adhere to the NEC and any local codes during the installation of ASD/motor systems. Excessive lead lengths may adversely effect the performance of the motor. Special cables are not required. Lead lengths from the ASD to the motor in excess of those listed in [Table 1](#) may require filters to be added to the output of the ASD. [Table 1](#) lists the suggested maximum lead lengths for the listed motor voltages.

Table 1. Lead Length Recommendations.

Model	PWM Carrier Frequency	NEMA MG-1-1998 Section IV Part 31 Compliant Motors ²
230 Volt	All	1000 feet
460 Volt	< 5 kHz	600 feet
	≥ 5 kHz	300 feet

Note: *Contact the Toshiba Customer Support Center for application assistance when using lead lengths in excess of those listed.*

Exceeding the peak voltage rating or the allowable thermal rise time of the motor insulation will reduce the life expectancy of the motor.

*When operating in the **Vector Control** mode the carrier frequency should be set to 2.2 kHz or above.*

I/O and Control

The H9 ASD can be controlled by several input types and combinations thereof, as well as operate within a wide range of output frequency and voltage levels. This section discusses the H9 ASD control methods and supported I/O functions.

The **Terminal Board** supports discrete and analog I/O functions and is shown in [Figure 9 on pg. 20](#). [Table 2](#) lists the names, functions, and default settings (of programmable terminals) of the input and output terminals of the **Terminal Board**.

Note: To use the input lines of the **Terminal Board** to provide **Run** commands the **Command Mode** setting must be set to **Terminal Block**.

[Figure 20 on pg. 22](#) shows the basic connection diagram for the H9 ASD system.

Table 2. Terminal Board Default Assignment Terminal Names and Functions.

Term. Name	Input/Output	Function (Default Setting If Programmable) (See Terminal Descriptions on pg. 18)	Circuit Config.
ST	Discrete Input Connect to CC to activate (Sink mode).	Standby — Multifunctional programmable discrete input. Activation required for normal ASD operation (see Installation Notes on pg. 10 for further information on this terminal).	Figure 10 on pg. 21.
RES		Reset — Multifunctional programmable discrete input. Resets ASD.	
F		Forward — Multifunctional programmable discrete input.	
R		Reverse — Multifunctional programmable discrete input.	
S1		Preset Speed 1 — Multifunctional programmable discrete input.	
S2		Preset Speed 2 — Multifunctional programmable discrete input.	
S3		Preset Speed 3 — Multifunctional programmable discrete input.	
S4		Preset Speed 4 — Multifunctional programmable discrete input.	
O1A/B (OUT1)	Switched Output	Low Speed — Multifunctional programmable discrete output.	Figure 16 on pg. 21.
O2A/B (OUT2)		Reach Frequency — Multifunctional programmable discrete output.	
FLA		Fault relay (N.O.).	Figure 19 on pg. 21.
FLB		Fault relay (N.C.).	
FLC		Fault relay (Common).	
RR	Analog Input	Frequency Mode 1 — Multifunction programmable analog input. (0.0 to 10 volt input — 0 Hz to Maximum Frequency).	Figure 11 on pg. 21.
RX		Multifunctional programmable analog input (-10 to +10 VDC input).	Figure 12 on pg. 21.
V/I (Select V or I via SW301)		Unassigned — V — Multifunctional programmable isolated analog voltage input (0 to 10 VDC input).	Figure 13 on pg. 21.
		Frequency Mode 2 (default SW301 setting) — I — Multifunctional programmable isolated analog current input (4 [0] to 20 mADC input — 0 Hz to Maximum Frequency).	
AM	Analog Output	Output Current — Current output that is proportional to the output current of the ASD or to the magnitude of the function assigned to this terminal.	Figure 18 on pg. 21
FM		Output Frequency — <u>Current</u> or <u>Voltage</u> output that is proportional to the output frequency of the ASD or to the magnitude of the function assigned to this terminal.	
SU+	DC Input	Externally-supplied 24 VDC backup control power (1.1 A min.).	
P24	DC Output	24 VDC output (200 mA max.).	Figure 14 on pg. 21.
PP		10.0 VDC/10 mA voltage source for an external potentiometer.	Figure 15 on pg. 21.
FP	Pulsed Output	Frequency Pulse — Multifunctional programmable output pulse train of a frequency based on the output frequency of the ASD.	Figure 17 on pg. 21.
IICC	—	Return for the V/I input terminal.	Do Not connect to Earth Gnd or to each other.
CCA	—	Return for the RR , RX , P24 , and the PP terminals.	
CC	—	Return for the AM , FM , SU+ , and the discrete input terminals.	

Terminal Descriptions

Note: The programmable terminal assignments may be accessed and changed from their default settings as mapped on [pg. 34](#) or via the **Direct Access** method: Program ⇒ Direct Access ⇒ **Applicable Parameter Number**. See the section titled [Program Mode Menu Navigation on pg. 34](#) for the applicable **Direct Access** parameter numbers.

For further information on terminal assignments and default setting changes, see the sections titled [Terminal on pg. 35](#) and [Default Setting Changes on pg. 62](#).

Note: See the section titled [Cable/Terminal/Torque Specifications on pg. 74](#) for the H9 ASD conductor and terminal electrical specifications.

Note: Programmable terminals will not retain their settings indefinitely in the event of a power loss. Connect an external +24 VDC supply to the **SU+** terminal to retain the programmable settings in the event of Control Power loss (see [Figure 20 on pg. 22](#)).

ST — The default setting for this terminal is the **Standby** mode controller. As the default setting, this terminal must be activated for normal system operation. The **ST** terminal is activated by connecting **CC** to this terminal (Sink mode). When deactivated, **OFF** is flashed on the LED Screen and the **Not-Ready-to-Run** indicator is displayed on the LCD Screen [Figure 22 on pg. 27](#). This input terminal may be programmed to any of the functions listed in the [H9 ASD Installation and Operation Manual](#) (see F113).

RES — The default setting for this terminal is **Reset**. The **RES** terminal is activated by connecting **CC** to this terminal (Sink mode). A momentary connection to **CC** resets the ASD and any fault indications from the display. **Reset** is effective when faulted only. This input terminal may be programmed to any of the functions listed in the [H9 ASD Installation and Operation Manual](#) (see F114).

F — The default setting for this terminal is **Forward** run command. The **F** terminal is activated by connecting **CC** to this terminal (Sink mode). This input terminal may be programmed to any of the functions listed in the [H9 ASD Installation and Operation Manual](#) (see F111).

R — The default setting for this terminal is **Reverse** run command. The **R** terminal is activated by connecting **CC** to this terminal (Sink mode). This input terminal may be programmed to any of the functions listed in the [H9 ASD Installation and Operation Manual](#) (see F112).

S1 — The default setting for this terminal is the **Preset Speed 1**. The **S1** terminal is activated by connecting **CC** to this terminal (Sink mode). This input terminal may be programmed to any of the functions listed in the [H9 ASD Installation and Operation Manual](#) (see F115).

S2 — The default setting for this terminal is the **Preset Speed 2**. The **S2** terminal is activated by connecting **CC** to this terminal (Sink mode). This input terminal may be programmed to any of the functions listed in the [H9 ASD Installation and Operation Manual](#) (see F116).

S3 — The default setting for this terminal is the **Preset Speed 3**. The **S3** terminal is activated by connecting **CC** to this terminal (Sink mode). This input terminal may be programmed to any of the functions listed in the [H9 ASD Installation and Operation Manual](#) (see F117).

S4 — The default setting for this terminal is the **Preset Speed 4**. The **S4** terminal is activated by connecting **CC** to this terminal (Sink mode). This input terminal may be programmed to any of the functions listed in the [H9 ASD Installation and Operation Manual](#) (see F118).

RR — The default function assigned to this terminal is **Frequency Mode 1**. The **RR** terminal accepts a 0 – 10 VDC input signal that is used to control the function assigned to this terminal. This input terminal may be programmed to control the speed or torque of the motor via an amplitude setting or to regulate by setting a limit. The gain and bias of this terminal may be adjusted for application-specific suitability (see F210 – F215). See [Figure 20 on pg. 22](#) for an electrical depiction of the **RR** terminal.

RX — The default function assigned to this terminal is **Torque Command**. The **RX** terminal accepts a ± 10 VDC input signal that is used to control the function assigned to this terminal. This input terminal may be programmed to raise or lower the speed or torque of the motor via an amplitude setting or this terminal may be used to regulate the speed or torque of a motor by setting a limit. The gain and bias of this terminal may be adjusted for application-specific suitability (see F216 – F221). See [Figure 20 on pg. 22](#) for an electrical depiction of the **RX** terminal.

V/I — The V/I terminal has the dual function of being able to receive an input voltage or current. The function as a voltage input to receive a 0 – 10 VDC input signal. The function as a current input is to receive a 0 – 20 mA input signal. Using either input type, the function is to control the 0.0 – Maximum Frequency output or the 0.0 to 250% torque output of the ASD. This is an isolated input terminal. This terminal may be programmed to control the speed or torque of the motor and cannot process both input types simultaneously. SW301 must be set to V or I to receive a voltage or current, respectively (see [Figure 9 on pg. 20](#)). Terminal scaling is accomplished via **F201 – F206**. The gain and bias of this terminal may be adjusted for application-specific suitability (see **F470** and **F471**).

SU+ — Externally (User) supplied +24 VDC $\pm 10\%$ at 1.1 A (minimum) backup control power.

P24 — +24 VDC at 200 mA power supply for customer use.

PP — The function of output **PP** is to provide a 10 VDC/10 mADC (max.) output that may be divided using a potentiometer. The tapped voltage is applied to the **RR** input to provide manual control of the **RR** programmed function.

O1A/B (OUT1A/B) — The default function assigned to this terminal is **Output Low Speed**. This output may be programmed to provide an indication (open or closed) that any of the functions listed in the *H9 ASD Installation and Operation Manual* has occurred or is active. This function may be used to signal external equipment (e.g., activate the brake) (see F130). The **OUT1** terminal is rated at 2 A/120 VAC and 2 A/30 VDC.

O2A/B (OUT2A/B) — The default function assigned to this terminal is **ACC/DEC Complete**. This output may be programmed to provide an indication (open or closed) that any of the functions listed in the *H9 ASD Installation and Operation Manual* has occurred or is active. This function may be used to signal external equipment (e.g., activate the brake) (see F131). The **OUT2** terminal is rated at 2 A/120 VAC and 2 A/30 VDC.

FP — The default function of this output terminal is to output a series of pulses at a rate that is a function of the ASD output frequency (50 mA max. at 1.0 kHz to 43.3 kHz). As the output frequency of the ASD goes up so does the **FP** output pulse rate. This terminal may be programmed to provide an output pulse rate that is proportional to the magnitude of the user-selected item listed in the *H9 ASD Installation and Operation Manual*.

AM — This output terminal produces an output current that is proportional to the magnitude of the function assigned to this terminal. The available assignments for this output terminal are listed in the *H9 ASD Installation and Operation Manual*.

FM — This output terminal produces an output current or voltage that is proportional to the magnitude of the function assigned to this terminal. The available assignments for this output terminal are listed in the *H9 ASD Installation and Operation Manual*. The Voltage/Current output selection is performed at **F681**.

FLA — One of two normally-closed contacts that, under user-defined conditions, connect to **FLC**.

FLB — One of two normally-open contacts that, under user-defined conditions, connect to **FLC**.

FLC — **FLC** is the common leg of a single-pole double-throw form C relay. The **FL** relay is the **Fault Relay** by default, but may be programmed to any of the selections listed in the *H9 ASD Installation and Operation Manual*. For further information on this terminal see **F132** and **Figure 8**.

Note: The **FLA**, **FLB**, and **FLC** contacts are rated at 2A/120 VAC and 2A/30 VDC.

Figure 8. FLA, FLB, and FLC Switching Contacts Shown in the Normal Operating Condition.

Note: The relay is shown in the normal operating condition. During a **faulted** condition the relay connection is **FLC-to-FLA**.

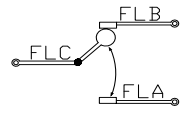
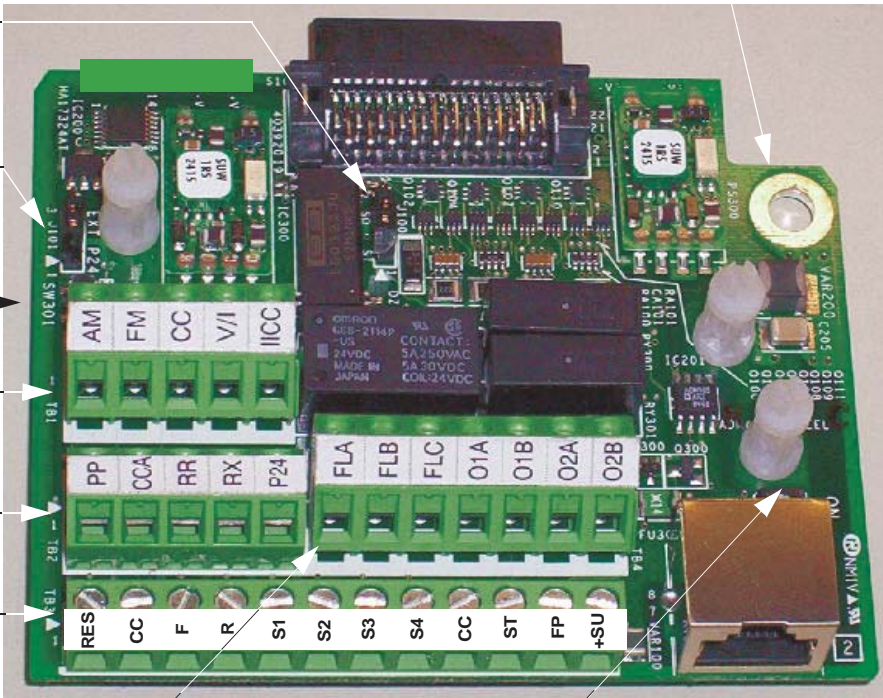

Figure 9. Terminal Board.

CAUTION Ensure that the ground screw is securely in place to prevent arcing, intermittent operation, or system failure.



J100
1 to 2 = Sink
2 to 3 = Source

J101 (24V)
1 to 2 = System Supplied
2 to 3 = Ext. Supplied

SW301
V/I Switch

TB1

TB2

TB3

TB4

SW200
Half/Full Duplex Switch

See **Figure 20** on pg. 22 for more information on the Terminal Board connections.

See the section titled [Terminal Descriptions](#) on pg. 18 for terminal descriptions.

See the section titled [Cable/Terminal/Torque Specifications](#) on pg. 74 for information on the proper cable/terminal sizes and torque specifications when making **Terminal Board** connections.

I/O Circuit Configurations

<p>Figure 10. Discrete Input.</p> <p>Input CC or 24 VDC 5 mA MAX.</p> <p>J100 Source 3 2 P24 Sink</p> <p>To Control Board</p>	<p>Figure 11. RR Input.</p> <p>30kΩ Input Impedance</p> <p>15kΩ</p> <p>15kΩ 0.047 μf</p> <p>CCA</p> <p>P5</p> <p>Use the CCA terminal as the RR signal return.</p>
<p>Figure 12. RX Input.</p> <p>30kΩ Input Impedance</p> <p>15kΩ</p> <p>7kΩ</p> <p>CCA</p> <p>P15</p> <p>Use the CCA terminal as the RX signal return.</p>	<p>Figure 13. V/I Isolated Input.</p> <p>256.7 kΩ Input Impedance</p> <p>I (Current)</p> <p>V (Voltage)</p> <p>SW301 Setting</p> <p>29.7 kΩ Input Impedance</p> <p>P15C P15A</p> <p>N15C N15A</p> <p>To Cont. Board</p> <p>IICC</p> <p>Use the IICC terminal as the V/I signal return.</p>
<p>Figure 14. P24 Output.</p> <p>Output</p> <p>24 VDC 200 mA Max.</p> <p>0.047 μf</p> <p>J101 1 (P24) 2 3 (EXT)</p> <p>Current Limiter</p> <p>P24</p> <p>CCA</p>	<p>Figure 15. PP Output.</p> <p>10 VDC (output)</p> <p>10 VDC 10 mA Max.</p> <p>0.047 μf</p> <p>Voltage Regulator</p> <p>CCA</p> <p>P15</p> <p>Use the CCA terminal as the PP signal return.</p>
<p>Figure 16. OUT1/OUT2 Output.</p> <p>O1A/O2A 2A/120VAC 2A/30VDC</p> <p>O1B/O2B</p> <p>OUT1/OUT2</p> <p>P24 Programmable</p>	<p>Figure 17. FP Output.</p> <p>1 to 43.2 KHZ 50 mA max.</p> <p>P5 Programmable</p> <p>P24</p> <p>FP</p> <p>4.7k</p>
<p>Figure 18. AM/FM Output.</p> <p>Output</p> <p>AM 0-1 mA or 0-7.5 VDC (see F670)</p> <p>FM 0-20 mA or 0-10 VDC (see F681)</p> <p>0.1 μf</p> <p>Low Pass Filter Circuit</p> <p>AM = 100 Ω FM = 68 Ω (0-20mA) 120 Ω (0-10VDC)</p> <p>P24 Programmable</p>	<p>Figure 19. Fault Relay (shown not faulted).</p> <p>2A/120VAC 2A/30VDC</p> <p>FLA FLB FLC</p> <p>P24</p> <p>F1</p> <p>Programmable</p>

Typical Connection Diagram

Figure 20. The H9 ASD Typical Connection Diagram.

Note: When connecting multiple wires to the PA, PB, PC, or PO terminals, do not connect a solid wire and a stranded wire to the same terminal.

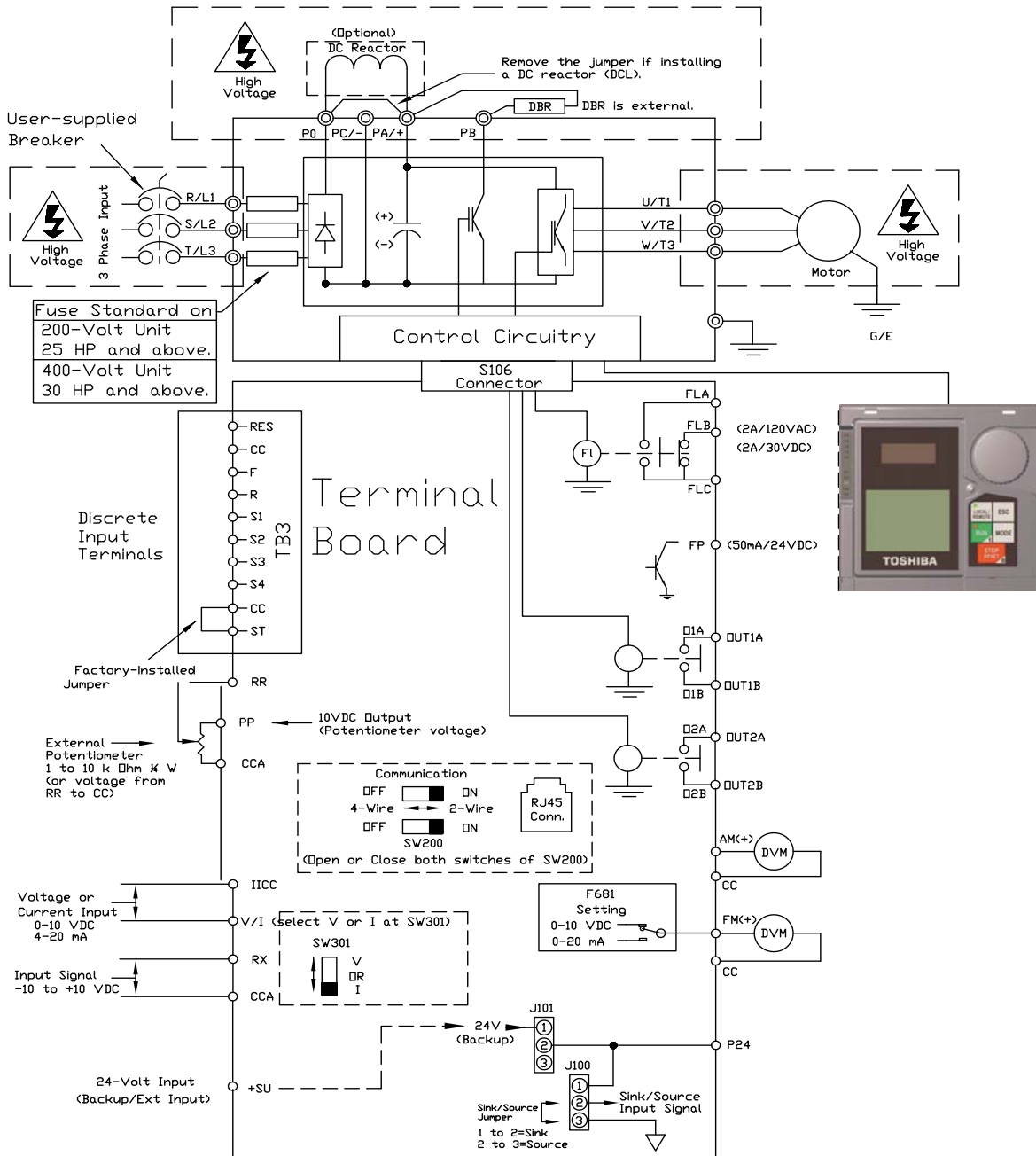

Note: The AM, FM, and the +SU analog terminals are referenced to CC.
 The PP, RR, RX, and the P24 analog terminals are referenced to CCA.
 The isolated V/I analog terminal references IICC.

Startup and Test

Before turning on the ASD ensure that:

- **R/L1, S/L2, and T/L3** are connected to the 3-phase input power.
- **U/T1, V/T2, and W/T3** are connected to the motor.
- The 3-phase input voltage is within the specified tolerance.
- There are no shorts and all grounds are secured.
- All personnel are at a safe distance from the motor and the motor-driven equipment.

Electronic Operator Interface

The H9 ASD **Electronic Operator Interface** (EOI) is comprised of an LED Screen, an LCD Screen, two LEDs, a rotary encoder, and five keys. These items are shown and described on [pg. 25](#).

EOI Operation

The **EOI** is the primary input/output device for the user. The **EOI** may be used to monitor system functions, input data into the system, perform diagnostics, and view performance data (e.g., motor frequency, bus voltage, torque, etc.).

The software used with the H9 ASD is menu driven; thus, making it a select and click environment. The operating parameters of a motor may be selected and viewed or changed using the **EOI** (or via communications).

EOI Remote Mounting

The **EOI** may be mounted remotely using the optional **ASD-MTG-KIT9**. The kit contains all of the hardware required to mount the **EOI** of the 9-Series ASD remotely.

System operation and **EOI** operation while using the remotely-mounted **EOI** are the same as with the ASD-mounted configuration.

EOI Features

Figure 21. The H9 ASD Electronic Operator Interface Features.

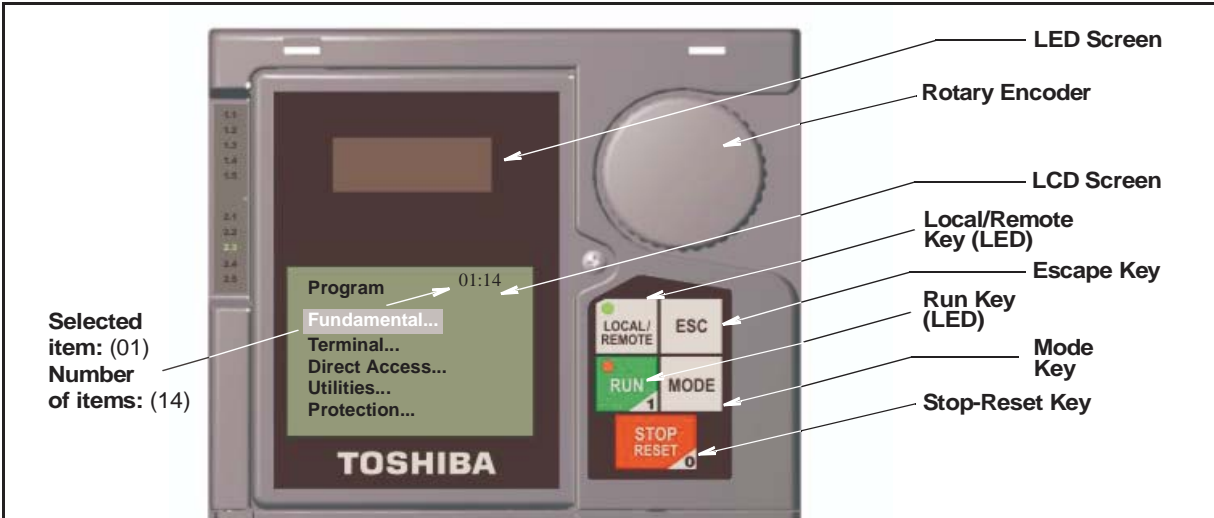

LED Screen — Displays the running frequency, active **Fault**, or active **Alarm** information.

Rotary Encoder — Used to access the H9 ASD menu selections, change the value of a displayed parameter, and performs the **Enter** key function. Turn the **Rotary Encoder** either clockwise or counterclockwise to perform the **Up** or **Down** functions of the displayed menu selection. Press the **Rotary Encoder** to perform the **Enter** (select) function.

LCD Screen— Displays configuration information, performance data (e.g., output frequency, bus voltage, torque, etc.), diagnostic information, and **LED Screen** information in expanded normal text.

Local/Remote Key — Toggles the system to and from the **Local** and **Remote** modes. The **Local/Remote Key** is disabled while the **Fault** screen is displayed. The LED is on when the system is in the **Local Command** mode. The **Local** mode allows the **Command** and **Frequency** control functions to be carried out via the **EOI**.

The **Remote** mode enables the **Command** and **Frequency** control functions to be carried out via the **Terminal Board**, **RS485**, **Communication Card**, or **Pulse Input**. The selection may be made via Program ⇒ Fundamental ⇒ Standard Mode Settings ⇒ [Command Mode](#).

The availability of **Local** mode control (**Command** and **Frequency** control) may be disabled via Program ⇒ Utilities ⇒ Prohibition ⇒ [Local/Remote Key Command Override](#) and [Local/Remote Key Frequency Override](#). The availability of the **Local** mode of operation may be reinstated by changing this setting or performing a **Reset** (see F007).

ESC Key — Returns the system to the previous level of the menu tree, toggles between the **EOI Command** screen and the **Frequency Command** screen, or cancels changes made to a field if pressed while still in the reverse video mode (dark background/light text). The three functions are menu-specific.

Run Key — Issues the **Run** command while in the **Local** mode. The **Run** key LED illuminates green while stopped or red while running to alert personnel.

Mode Key — Provides a means to access the three root menus. Pressing the **Mode Key** key repeatedly loops the system through the three root menus (see [Figure 25 on pg. 29](#)). While looping through the root menus, the **Program** menu will display the root menu screen or the **Program** sub-menu item being accessed prior to pressing the **Mode** key.

Stop-Reset Key — This key has three functions.

1. Issues the **Off** command (decelerates to **Stop** at the programmed rate) if pressed once while in the **Local** mode in accordance with the setting of **F721**.
2. Initiates an **Emergency Off Fault** if pressed twice quickly from the **Local** or **Remote** modes. The **Emergency Off** function terminates the H9 ASD output and stops the motor in accordance with the setting of **F603**.
3. Resets active **Faults** and/or active **Alarms** if pressed twice quickly. The source of the **Faults** or **Alarms** must be determined and corrected before normal ASD operation can resume.

LED/LCD Screen

The LED Screen is used to display the output frequency, active alarms and/or active faults.

If there are no active alarms or faults, the output frequency is displayed.

During an active alarm, the display toggles to and from the running frequency and the active alarm.

During an active fault, the fault is displayed.

Loss of the **ST-to-CC** connection flashes **Off**.

LED Character/Font Information

Characters displayed on the LED Screen will be of the seven-segment format. Not all alpha-numeric characters are available or used with the LED Screen.

Listed are the seven-segment characters used on the LED Screen along with the same characters as they are displayed on the LCD Screen.

LCD Font Information

All alpha-numeric are used.

LED/LCD Screen Information			
LED	LCD	LED	LCD
A	A	1	1
b	b	2	2
C	C	3	3
d	d	4	4
E	E	5	5
F	F	6	6
G	G	7	7
H	H	8	8
I	I	9	9
J	J	0	0
L	L		
M	M		
n	n		
O	O		
P	P		
q	q		
r	r		
S	S		
t	t		
U	U		
v	v		
y	y		
-	-		

LCD Screen

The **LCD Screen** is the primary user input/output information center. Parameter settings may be viewed or changed using the LCD Screen module of the **EOI**. To view or change a parameter setting using the LCD Screen, press the **Mode** key until the **Program** menu is displayed. Turn the **Rotary Encoder** until the **Primary Menu** item (see pg. 34) is within the cursor block. Press the **Rotary Encoder** to select the item from the **Primary Menu** (repeat the press-to-select for submenu items).

See the section titled [Default Setting Changes on pg. 62](#) for more information on changing parameter settings.

Upon reaching the desired parameter selection the current setting may be viewed, or selected and changed by pressing the **Rotary Encoder** and the setting will take on the reverse video format (dark background/light text). Turn the **Rotary Encoder** to change the parameter setting. Press the **ESC** key while the new parameter setting is in the reverse video mode to exit the selection without saving the change or press the **Rotary Encoder** while the parameter setting is in the reverse video mode to accept the change.

Repeated **ESC** key entries at any time takes the menu back one level each time the **ESC** key is pressed until the **Frequency Command** screen is reached. Further **ESC** entries will toggle the system to and from the **Frequency Command** screen and the **EOI Command** menu.

*Note: Changes carried out from the **EOI Command** screen will be effective for EOI-controlled ASD operation only. See the section titled [EOI Command Mode on pg. 30](#) for further information on **EOI Command Mode** operations.*

Primary Menus of the LCD Screen

The three primary screens of the LCD Screen are displayed while accessing the associated operating mode: the **Frequency Command**, **Monitor**, and the **Program Menu** screens.

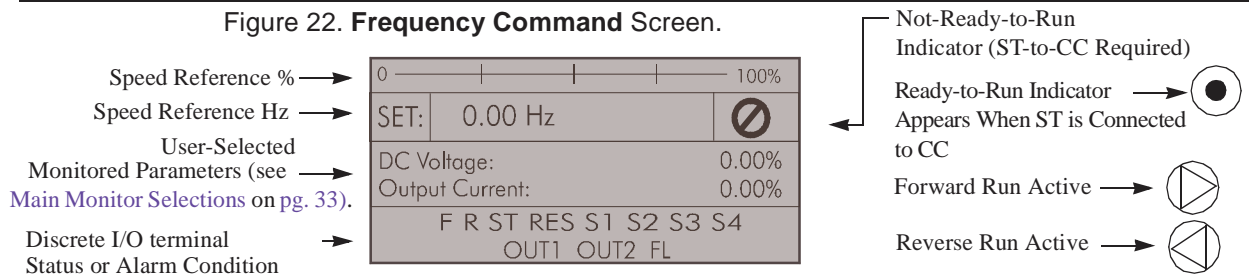

Figure 23. **Monitor Screen** (see [pg. 31](#) for more on the Monitor Screen items).

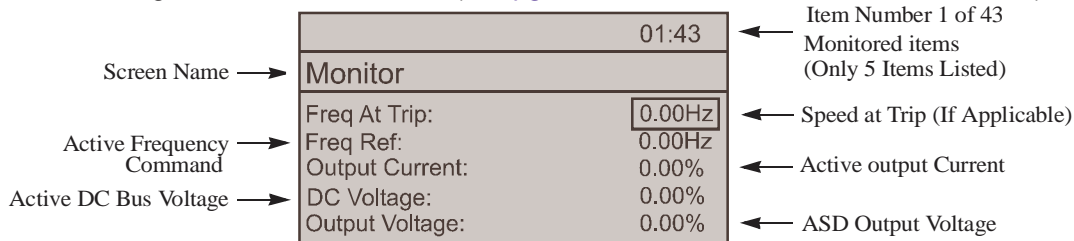
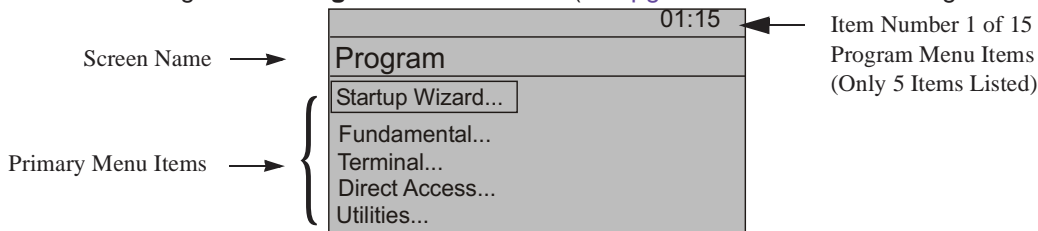

Figure 24. **Program Menu Screen** (see [pg. 34](#) for more on the Program Menu Screen).



LED/LCD Screen Installation Note

When installing the LED/LCD Screen module of the **EOI** ensure that the left side of the display is inserted first with the top and bottom catches (see Phillips screws at underside of display) securely in place. This ensures the proper alignment and electrical connection of the CNX connector of the **LED/LCD Screen** module PCB. Gently hold the display in place while securing the Phillips mounting screw.

If improperly seated, the periphery of the **LED/LCD Screen** module will not be flush with the front panel surface and the unit will not function properly.

System Configuration and Menu Options

Root Menu

The **Mode** key accesses the three primary modes of the H9 ASD: the **Frequency Command** mode, the **Monitor** mode, and the **Program** mode. From either mode, press the **Mode** key to loop through to the other two modes (see Figure 25). While in the **Frequency Command** mode, pressing the **ESC** key toggles the menu to and from the **EOI Command** mode and the **Frequency Command** mode.

The **Alarm** or **Fault** information will be displayed in the event of an active **Alarm** or **Fault**. **Alarm** text will be displayed on the **Frequency Command** screen and on the LED Screen when active. **Fault** information will be displayed via the **Fault** screen. See the *H9 ASD Installation and Operation Manual* for more information on **Alarms** and **Trips**.

Note: EOI Command mode changes are effective for EOI control operation Only.

Figure 25. H9 ASD Root Menu Navigation.

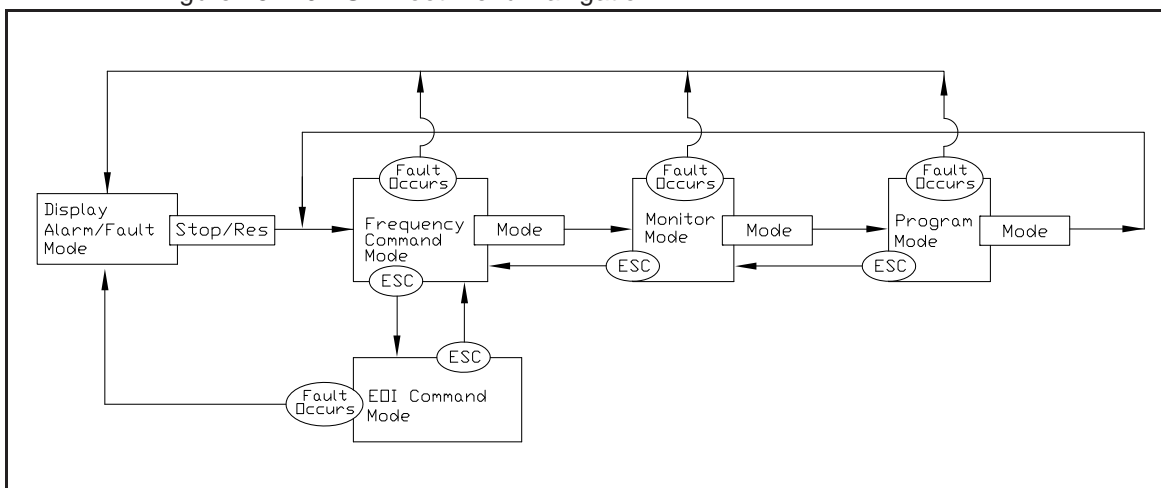

Frequency Command Mode

Frequency Setting

While operating in the **Local** mode (Local LED is illuminated on the front panel), the running frequency of the motor may be set from the **Frequency Command** screen. Using the **Rotary Encoder**, enter the **Frequency Command** value, connect **ST** to **CC**, and provide a **Run** command (F and/or R) and then press the **Run** key. The motor will run at the **Frequency Command** speed and may be changed while running. See Figure 22 on pg. 27 and Operation (Local) on pg. 61 for more information on the **Frequency Command** mode.

EOI Command Mode

The **EOI Command** mode is accessed by pressing the **ESC** key from the **Frequency Command** screen.

The control settings of the **EOI Command** menu are effective for **LCD EOI** control only.

The **EOI Command** mode provides quick access to the following menu parameters:

Direction — **Forward** or **Reverse**.

Stop Pattern — The **Decel Stop** or **Coast Stop** settings determines the method used to stop the motor when using the **Stop-Reset** key of the **EOI**. The **Decel Stop** setting enables the **Dynamic Braking** system setup at **F304** or the **DC Injection Braking** system setup at **F250**, **F251**, and **F252**. The **Coast Stop** setting allows the motor to stop at the rate allowed by the inertia of the load.

Note: The **Stop Pattern** setting has no effect on the **Emergency Off** settings of **F603**.

V/f Group — One of 4 **V/f** profiles may be selected and run. Each **V/f** profile is comprised of 4 user settings: **Base Frequency**, **Base Frequency Voltage**, **Manual Torque Boost**, and **Electronic Thermal Protection**. Expanded descriptions of these parameters may be found in the section titled Direct Access Parameter Information in the *H9 ASD Installation and Operation Manual*.

Accel/Decel Group — One of 4 **Accel/Decel** profiles may be selected and run. Each of the **Accel/Decel** profiles is comprised of three user settings: **Acceleration**, **Deceleration**, and **Pattern**. Expanded descriptions of these parameters may be found in the section titled Direct Access Parameter Information in the *H9 ASD Installation and Operation Manual*.

Feedback in Panel Mode — This feature enables or disables the **PID** feedback function.

Torque Limit Group — This parameter is used to select 1 of 4 preset positive torque limits to apply to the active motor (of a multiple motor configuration). The settings of profiles 1 – 4 may be setup at **F441**, **F444**, **F446**, and **F448**, respectively.

Monitor Mode

The **Monitor** mode allows the user to monitor motor performance variables, control settings, and configuration data during motor operation. The items that are viewable from this mode are listed and described below.

Note: The **Monitor** mode is a read-only mode. The settings cannot be changed from the **Monitor** mode. For information on how to change the values, see the section titled *Default Setting Changes on pg. 62*.

Note: Any two of the Underlined monitored items may be selected for display on the **Frequency Command** screen while running via Program ⇒ Utilities ⇒ *Main Monitor Selections* (see pg. 33 for information on using the *Main Monitor Selections* feature).

Note: The **F701** setting will determine if the Current and Voltage values displayed appear as A (Amps) and V (Voltage), or if the value is shown as a % (percentage) of the ASD rating.

Frequency at Trip — Display the at-trip frequency.

Frequency Reference — Displays the **Frequency Setpoint**.

Output Current — Displays the **Output Current** as a percentage of the rated capacity of the H9 ASD.

DC Bus Voltage — Displays the **Bus Voltage** as a percentage of the rated capacity of the H9 ASD.

Output Voltage — Displays the **Output Voltage** as a percentage of the rated capacity of the H9 ASD.

AM Output — Displays the **AM** output terminal value for the function assigned to the **AM** terminal.

FM Output — Displays the **FM** output terminal value for the function assigned to the **FM** terminal.

Motor OL (Overload) Real — Displays the real-time **Motor Overload** value as a percentage of the rated capacity of the motor.

Motor OL (Overload) Trip — Displays the **Motor Overload Trip** value as a percentage of the rated capacity of the motor.

Motor Load — Displays the real-time **Motor Load** as a percentage of the rated capacity of the motor.

ASD OL (Overload) Real — Displays the real-time **ASD Overload** as a percentage of the rated capacity of the H9 ASD.

ASD OL (Overload) Trip — Displays the **ASD Overload Trip** value as a percentage of the rated capacity of the ASD.

ASD Load — Displays the **ASD Load** as a percentage of the rated capacity of the H9 ASD.

Run Time — Displays the **Cumulative Run Time** in hours.

Compensation Frequency — Displays the **Output Frequency** after the application of the slip compensation correction value (Post Compensation Frequency).

DBR OL (Overload) Real — Displays the real-time **DBR Overload** value as a percentage of the **Dynamic Braking Resistor** capacity.

DBR OL (Overload) Trip — Displays the **DBR Overload Trip** value as a percentage of the **Dynamic Braking Resistor** capacity.

DBR Load — Displays the **DBR Load** as a percentage of the **Dynamic Braking Resistor** capacity.

Feedback (inst) — Provides a status of the **Real Time Feedback** in Hz.

Feedback (1 second) — Provides a status of the **1-Second Averaging** feedback in Hz.

Torque — Displays the **Output Torque** as a percentage of the rated capacity of the H9 ASD.

Torque Reference — Displays the **Torque Reference** as a percentage.

Torque Current — Displays the torque-producing current value.

Excitation Current — Displays the current value required to produce the excitation field.

PID Feedback — Provides a status of the **PID Real Time Feedback** in Hz.

Input Power — Displays the **Input Power** in Kilowatts (kW).

Output Power — Displays the **Output Power** in Kilowatts (kW).

Pattern Group Number — Displays the active **Pattern Run Group Number**.

Pattern Group Cycle — Displays the cycle number of the active **Pattern Run Group**.

Pattern Group Preset — Displays the active **Preset Speed** being run of the active **Pattern Run Group**.

Pattern Time — Displays the remaining time for the active **Pattern Run Group**.

RR — Displays the **RR** input value as a percentage of the full range of the **RR** value (potentiometer input).

VI/II (V/I) — Displays the **V/I** input setting as a percentage of the full range of the **V/I** value.

*Note: The isolated **VI/II (V/I)** input terminal may receive **Current** or **Voltage** to control the output speed or the output torque. The input signal type must be selected at **SW301** on the **Terminal Board**.*

*The **V** input setting of **SW301** is used for the 0 – 10 VDC analog input signal and the **I** input setting of **SW301** is used for the 0 – 20 mA analog input signal. Either may be used as a frequency or torque command source. See parameter **F201** for more information on the setup of this terminal.*

*On the LCD Screen the **VI/II (V/I)** terminal is listed as the **VI/II** terminal (the second character **I** is used to indicate “input.”).*

RX — Displays the **RX** input setting as a percentage of the full range of the **RX** value (-10 to +10 VDC input).

RX2 Option (AI1) — Displays the **RX2** input setting as a percentage of the full range of the **RX2** value.

*Note: The **RX2** function is available on the **Expansion IO Card Option 1** option board (P/N ETB003Z) only.*

Trip Code — Displays **None** if there are no errors, or displays one of the associated **Fault Codes** listed in the *H9 ASD Installation and Operation Manual* if there is an active **Fault** (e.g., **E** = **Emergency Off**).

Past Trip 1 — This function records and displays the last trip incurred. Subsequent trips will replace **Past Trip 1**. As trip records are replaced they are shifted to the next level of the **Past Trip** locations until being deleted (i.e., Past Trip 1 is moved to Past Trip 2 and then to 3 until being shifted out of 4). Once shifted out of **Past Trip 4** the record is deleted. If no trips have occurred since the last reset, **None** is displayed for each trip record.

Past Trip 2 — Past Trip information or **None**.

Past Trip 3 — Past Trip information or **None**.

Past Trip 4 — Past Trip information or **None**.

Note: An improper H9 ASD setup may cause some trips — reset the H9 ASD to the **Factory Default** settings before pursuing a systemic malfunction (Program ⇒ Utilities ⇒ Type Reset ⇒ **Reset to Factory Settings**).

Direction — Displays the **Direction** command (forward/reverse).

Discrete Input Terminals — Displays the status (Activated = reverse video) of the discrete input terminals of the **Terminal Board**.

Discrete Output Terminals — Displays the status (Activated = reverse video) of the discrete output lines of the **Terminal Board**.

Main Monitor Selections

Two (2) **Monitor Mode** items may be selected from the **Main Monitor Selections** screen to be displayed on the **Frequency Command** screen while the H9 ASD is running.

The selected items, along with their real-time values, are displayed on the **Frequency Command** screen while running. Not all **Monitor Mode** items are available for display on the **Frequency Command** screen. The available items are underlined on [pg. 31](#) and [pg. 32](#).

Any two of the underlined items may be selected from the listing at Program ⇒ Utilities ⇒ **Main Monitor Selections**. Select an item from the **Monitor 1** listing and another item from the **Monitor 2** listing to be displayed as shown in [Figure 22 on pg. 27](#).

Program Mode Menu Navigation

The following table lists the menu items of the **Program** mode and maps the flow of the menu selections. The **Parameter Numbers** for the listed functions are provided where applicable.

The functions listed may be viewed, or selected and changed as mapped below or via the **Direct Access** method: Program ⇒ Direct Access ⇒ *Applicable Parameter Number*.

Program Mode Menu Navigation			
Primary Menu	Sub Menu	Parameter Name	Parameter Number
STARTUP WIZARD	See the section titled Initial Setup on pg. 58 for Startup Wizard Requirements.		
FUNDAMENTAL	Accel/Decel 1 Settings	Automatic Acceleration/Deceleration	F000
		Acceleration Time 1	F009
		Deceleration Time 1	F010
		Acceleration/Deceleration Suspended Function	F349
		Acceleration Suspend Frequency	F350
		Acceleration Suspend Time	F351
		Deceleration Suspend Frequency	F352
		Deceleration Suspend Time	F353
	Frequency Settings	Maximum Frequency	F011
		Upper-Limit Frequency	F012
		Lower-Limit Frequency	F013
		V/f Pattern	F015
		Time Limit for Lower-Limit Frequency Operation	F256
	Motor Set 1	Automatic Torque Boost	F001
		Base Frequency 1	F014
		Manual Torque Boost 1	F016
		Motor Overload Protection Level 1	F600
	Standard Mode Selection	Command Mode	F003
		Frequency Mode 1	F004
		Forward/Reverse Run	F008
		Frequency Priority	F200
		Frequency Mode 2	F207
		Frequency Mode Priority Switching Frequency	F208
TERMINAL	Analog Output Terminals	FM Output Terminal Function	F005
		FM Output Terminal Adjustment	F006

Program Mode Menu Navigation			
Primary Menu	Sub Menu	Parameter Name	Parameter Number
TERMINAL	Analog Output Terminals	FM Output Gradient Characteristic	F682
		FM Bias Adjustment	F683
		FM Voltage/Current Output Switching	F681
		AM Output Terminal Function	F670
		AM Output Terminal Adjustment	F671
		AM Output Gradient Characteristic	F685
		AM Bias Adjustment	F686
		MON 1 Terminal Meter Selection	F672
		MON 1 Terminal Meter Adjustment	F673
		MON 1 Output Gradient Characteristic	F689
		MON 1 Bias Adjustment	F690
		MON 1 Voltage/Current Output Switching	F688
		MON 2 Terminal Meter Selection	F674
		MON 2 Terminal Meter Adjustment	F675
		MON 2 Output Gradient Characteristic	F692
		MON 2 Bias Adjustment	F693
		MON 2 Voltage/Current Output Switching	F691
		Pulse Output Function	F676
		Pulse Output Frequency	F677
		Input Special Functions	Forward/Reverse Run Priority When Both Are Activated
	Input Terminal Priority		F106
	16-Bit Binary/BCD Input		F107
	VI/II (V/I) Analog Input Broken Wire Detection Level		F633
	Input Terminal Delays	Input Terminal 1 (F) Response Time	F140
		Input Terminal 2 (R) Response Time	F141
		Input Terminal 3 (ST) Response Time	F142
		Input Terminal 4 (RES) Response Time	F143
		Input Terminal 5–12 Response Time	F144
		Input Terminal 13–20 Response Time	F145

Program Mode Menu Navigation			
Primary Menu	Sub Menu	Parameter Name	Parameter Number
TERMINAL	Input Terminals	Always ON Terminal Function	F110
		Input Terminal 1 (F) Function	F111
		Input Terminal 2 (R) Function	F112
		Input Terminal 3 (ST) Function	F113
		Input Terminal 4 (RES) Function	F114
		Input Terminal 5 (S1) Function	F115
		Input Terminal 6 (S2) Function	F116
		Input Terminal 7 (S3) Function	F117
		Input Terminal 8 (S4) Function	F118
		Input Terminal 9 (LI1) Function	F119
		Input Terminal 10 (LI2) Function	F120
		Input Terminal 11 (LI3) Function	F121
		Input Terminal 12 (LI4) Function	F122
		Input Terminal 13 (LI5) Function	F123
		Input Terminal 14 (LI6) Function	F124
		Input Terminal 15 (LI7) Function	F125
		Input Terminal 16 (LI8) Function	F126
		Input Terminal 17 (B12) Function	F164
		Input Terminal 18 (B13) Function	F165
		Input Terminal 19 (B14) Function	F166
	Input Terminal 20 (B15) Function	F167	
	Virtual Input Terminal Selection 1	F973	
	Virtual Input Terminal Selection 2	F974	
	Virtual Input Terminal Selection 3	F975	
	Virtual Input Terminal Selection 4	F976	
	Line Power Switching	Commercial Power/ASD Switching Output	F354
		Commercial Power/ASD Switching Frequency	F355
ASD Side Switching Delay Time		F356	
Commercial Power-Side Switching Delay Time		F357	
Commercial Power Switching Frequency Hold Time		F358	

Program Mode Menu Navigation			
Primary Menu	Sub Menu	Parameter Name	Parameter Number
TERMINAL	Output Terminals	Output Terminal 1 (OUT1) Function	F130
		Output Terminal 2 (OUT2) Function	F131
		Output Terminal 3 (FL) Function	F132
		Output Terminal 4 (OUT3) Function	F133
		Output Terminal 5 (OUT4) Function	F134
		Output Terminal 6 (R1) Function	F135
		Output Terminal 7 (OUT5) Function	F136
		Output Terminal 8 (OUT6) Function	F137
		Output Terminal 9 (R2) Function	F138
		Output Terminal 10 (R3) Function	F168
	Output Terminal 11 (R4) Function	F169	
	Reach Settings	Low Speed Signal Output Frequency	F100
		Speed Reach Frequency	F101
Speed Reach Detection Band		F102	
DIRECT ACCESS	Parameter Number Input	N/A	
	Unknown Numbers Accepted		
UTILITIES	Display Parameters	Automatic Function Selection	F040
		Voltage/Current Display Units	F701
		Free Unit Multiplication Factor	F702
		Free Unit	F703
		Free Unit Display Gradient Characteristic	F705
		Free Unit Display Bias	F706
		Change Step Selection 1	F707
		Change Step Selection 2	F708
	Prohibition	Write Parameter Lockout	F700
		Command Mode/Frequency Mode Lockout	F736
		Lockout All Keys	F737
		Local/Remote Key Command Override	N/A
		Local/Remote Key Frequency Override	
	Trace	Trace Selection	F740

Program Mode Menu Navigation			
Primary Menu	Sub Menu	Parameter Name	Parameter Number
UTILITIES	Trace	Trace Cycle	F741
		Trace Data 1	F742
		Trace Data 2	F743
		Trace Data 3	F744
		Trace Data 4	F745
	Alarm Prohibition (prohibits an EOI alarm display ONLY — alarm still activated)	Over-Current Alarm	N/A
		ASD Overload Alarm	
		Motor Overload Alarm	
		Over-Heat Alarm	
		Over-Voltage Alarm	
		Main Power Under-Voltage Alarm	
		Reserved (POFF) Alarm	
		Under-Current Alarm	
		Over-Torque Alarm	
		Braking Resistor Overload Alarm	
		Cumulative Run Timer Alarm	
		DeviceNet/Profibus/CC-Link Alarm	
		RS485 Communication	
		Main Power Under-Voltage Alarm	
		Stop After Instantaneous Power-off Alarm	
		Stop After Lower-Limit Continuous Time	
		Light-Load Alarm	
		Heavy-Load Alarm	
	Maintenance Timer Alarm		
	Over-Torque Alarm		
	Soft Stall Alarm		
	Type Reset	Reset	F007
	Real-Time Clock Setup	Set Real-Time Clock	N/A
Trip History (read-only)	Trip Number	N/A	
	Trip Type		

Program Mode Menu Navigation			
Primary Menu	Sub Menu	Parameter Name	Parameter Number
UTILITIES	Trip History (read-only)	Frequency at Trip	N/A
		Output Current	
		Output Voltage	
		Direction	
		Frequency Reference	
		DC Voltage	
		Discrete Input Terminals	
		Discrete Output Terminals	
		Run Timer	
		Post Compensation Frequency	
		Speed Feedback (Real-Time)	
		Speed Feedback (1 Second)	
		Torque Feedback	
		Torque Reference	
		Torque Current	
		Excitation Current	
		PID Feedback	
		Motor Overload Ratio	
		ASD Overload Ratio	
		DBR Overload Ratio	
		Motor Load	
		ASD Load	
	DBR Load		
	Input Power		
	Output Power		
	Changed From Default	Changed Parameters	N/A
	Contrast	Contrast Adjustment	N/A
	Version (read-only)	H9 EOI (Ver:DB)	N/A
ASD Type			
CPU Code Version			

Program Mode Menu Navigation			
Primary Menu	Sub Menu	Parameter Name	Parameter Number
UTILITIES	Version (read-only)	CPU Code Revision	N/A
		MC Version	
		MC Revision	
		Main Board EEPROM Version	
	Main Monitor Selections	Monitor 1	
		Monitor 2	
View Trace Data	View Trace Data		
PROTECTION	Abnormal Speed Settings	Abnormal Speed Detection Time	F622
		Over-Speed Detection Frequency Upper Band	F623
		Over-Speed Detection Frequency Lower Band	F624
	Base Frequency Voltage	Supply Voltage Correction	F307
	DC Injection Braking	DC Injection Braking Start Frequency	F250
		DC Injection Braking Current	F251
		DC Injection Braking Time	F252
		Forward/Reverse DC Injection Braking Priority	F253
		Motor Shaft Stationary Control	F254
	Dynamic Braking	Dynamic Braking Enable	F304
		Dynamic Braking Resistance	F308
		Continuous Dynamic Braking Capacity	F309
		Braking Resistance Overload Time (10x Rated Torque)	F639
	Emergency Off Settings	Emergency Off	F603
		Emergency DC Injection Braking Control Time	F604
	Low-Current Settings	Low-Current Trip	F610
		Low-Current Detection Current	F611
		Low-Current Detection Time	F612
		Low-Current Detection Hysteresis Width	F609
	Overload	Motor Overload Protection Configuration	F017
		Overload Reduction Start Frequency	F606

Program Mode Menu Navigation			
Primary Menu	Sub Menu	Parameter Name	Parameter Number
PROTECTION	Overload	Motor 150% Overload Time Limit	F607
		ASD Overload	F631
	Over-Torque Parameters	Over-Torque Trip	F615
		Over-Torque Detection Level During Power Running	F616
		Over-Torque Detection Level During Regenerative Braking	F617
		Over-Torque Detection Time	F618
		Over-Torque Detection Hysteresis	F619
	Phase Loss	ASD Output Phase Loss Detection	F605
		ASD Input Phase Loss Detection	F608
	Retry/Restart	Auto Restart Enable	F301
		Number of Times to Retry	F303
		Ridethrough Time	F310
		Random Mode	F312
	Stall	Over-Voltage Limit Operation	F305
		Stall Prevention Factor 1	F416
		Power Running Stall Continuous Trip Detection Time	F452
		Stall Prevention During Regeneration	F453
		Stall Prevention Level	F601
		Over-Voltage Limit Operation Level	F626
	Trip Settings	Retain Trip Record at Power Down	F602
	Under-Voltage/ Ridethrough	Regenerative Power Ridethrough Mode	F302
		Synchronized Deceleration Time	F317
		Synchronized Acceleration Time	F318
		Under-Voltage Trip	F627
		Under-Voltage (Trip Alarm) Detection Time	F628
		Regenerative Power Ridethrough Control Level	F629
	Special Protection Parameters	Short Circuit Detection at Start	F613
		Cooling Fan Control	F620
		Cumulative Operation Time Alarm Setting	F621
		Brake Answer Wait Time	F630

Program Mode Menu Navigation			
Primary Menu	Sub Menu	Parameter Name	Parameter Number
FREQUENCY	Analog Filter	Analog Input Filter	F209
	Forward/Reverse Disable	Forward/Reverse Disable	F311
	Jog Settings	Jog Frequency	F260
		Jog Stop Pattern	F261
		Panel Operation Jog Mode	F262
	UP/DOWN Frequency Functions	UP/DOWN Up Response Time	F264
		UP/DOWN Up Frequency Step	F265
		UP/DOWN Down Response Time	F266
		UP/DOWN Down Frequency Step	F267
		Initial UP/DOWN Frequency	F268
		Initial UP/DOWN Frequency Rewriting	F269
	VI/II (V/I) Settings	Option VI/II (V/I) Terminal Voltage/Current Selection (AI2 option board input)	F109
	Preset Speeds	Preset Speed 1	F018
		Preset Speed 2	F019
		Preset Speed 3	F020
		Preset Speed 4	F021
		Preset Speed 5	F022
		Preset Speed 6	F023
		Preset Speed 7	F024
		Preset Speed 8	F287
		Preset Speed 9	F288
		Preset Speed 10	F289
		Preset Speed 11	F290
Preset Speed 12		F291	
Preset Speed 13		F292	
Preset Speed 14		F293	
Preset Speed 15		F294	

Program Mode Menu Navigation			
Primary Menu	Sub Menu	Parameter Name	Parameter Number
FREQUENCY	Speed Reference Setpoints	VI/II (V/I) Input Point 1 Setting	F201
		VI/II (V/I) Input Point 1 Frequency	F202
		VI/II (V/I) Input Point 2 Setting	F203
		VI/II (V/I) Input Point 2 Frequency	F204
		RR Input Point 1 Setting	F210
		RR Input Point 1 Frequency	F211
		RR Input Point 2 Setting	F212
		RR Input Point 2 Frequency	F213
		RX Input Point 1 Setting	F216
		RX Input Point 1 Frequency	F217
		RX Input Point 2 Setting	F218
		RX Input Point 2 Frequency	F219
		RX2 Option (AI1) Input Point 1 Setting	F222
		RX2 Option (AI1) Input Point 1 Frequency	F223
		RX2 Option (AI1) Input Point 2 Setting	F224
		RX2 Option (AI1) Input Point 2 Frequency	F225
		BIN Input Point 1 Setting	F228
		BIN Input Point 1 Frequency	F229
		BIN Input Point 2 Setting	F230
		BIN Input Point 2 Frequency	F231
		PG Input Point 1 Setting	F234
		PG Input Point 1 Frequency	F235
		PG Input Point 2 Setting	F236
		PG Input Point 2 Frequency	F237
		VI/II (V/I) Input Bias	F470
		VI/II (V/I) Input Gain	F471
		RR Input Bias	F472
		RR Input Gain	F473
RX Input Bias	F474		
RX Input Gain	F475		

Program Mode Menu Navigation			
Primary Menu	Sub Menu	Parameter Name	Parameter Number
FREQUENCY	Speed Reference Setpoints	RX2 Option (AI1) Input Bias	F476
		RX2 Option (AI1) Input Gain	F477
		VI/II (V/I) Input Bias (AI2 Option Board Input)	F478
		VI/II (V/I) Input Gain (AI2 Option Board Input)	F479
SPECIAL	Acc/Dec 1 – 4 Settings	Acceleration Time 2	F500
		Deceleration Time 2	F501
		Acc/Dec Pattern 1	F502
		Acc/Dec Pattern 2	F503
		Acceleration Time 3	F510
		Deceleration Time 3	F511
		Acc/Dec Pattern 3	F512
		Acceleration Time 4	F514
		Deceleration Time 4	F515
		Acc/Dec Pattern 4	F516
	Acc/Dec Special	Acc/Dec Pattern 1 – 4	F504
		Acc/Dec Switching Frequency 1	F505
		S-Pattern Acceleration Lower-Limit Adjustment	F506
		S-Pattern Acceleration Upper-Limit Adjustment	F507
		S-Pattern Deceleration Lower-Limit Adjustment	F508
		S-Pattern Deceleration Upper-Limit Adjustment	F509
		Acc/Dec Switching Frequency 2	F513
		Acc/Dec Switching Frequency 3	F517
	Carrier Frequency	PWM Carrier Frequency	F300
		Carrier Frequency Control Mode	F316
	Crane/Hoist Settings	Light-Load/High-Speed Operation	F328
		Light-Load/High-Speed Learning Function	F329
		Light-Load/High-Speed Operation Frequency	F330
		Light-Load/High-Speed Operation Switching Lower-Limit Frequency	F331
		Light-Load/High-Speed Operation Load Wait Time	F332
		Light-Load/High-Speed Operation Detection Time	F333

Program Mode Menu Navigation			
Primary Menu	Sub Menu	Parameter Name	Parameter Number
SPECIAL	Crane/Hoist Settings	Light-Load/High-Speed Heavy-Load Detection Time	F334
		Switching Load Torque During Power Running	F335
		Heavy-Load Torque During Power Running	F336
		Heavy-Load Torque During Constant Power Running	F337
		Switching Load Torque During Regeneration Braking	F338
	V/f 5-Point Setting	V/f 5-Point Setting Frequency 1	F190
		V/f 5-Point Setting Voltage 1	F191
		V/f 5-Point Setting Frequency 2	F192
		V/f 5-Point Setting Voltage 2	F193
		V/f 5-Point Setting Frequency 3	F194
		V/f 5-Point Setting Voltage 3	F195
		V/f 5-Point Setting Frequency 4	F196
		V/f 5-Point Setting Voltage 4	F197
		V/f 5-Point Setting Frequency 5	F198
		V/f 5-Point Setting Voltage 5	F199
	Frequency Control	Start Frequency	F240
		Run Frequency	F241
		Run Frequency Hysteresis	F242
		End Frequency	F243
	Special Parameters	0 Hz Dead Band Signal	F244
		0 Hz Command Output	F255
		Exciting Strengthening Coefficient	F415
		Annual Average Ambient Temperature	F634
		Rush Current Suppression Relay Activation Time	F635
		PTC 1 Thermal Selection	F637
		PTC 2 Thermal Selection	F638
	Jump Frequencies	Jump Frequency 1	F270
		Jump Frequency 1 Bandwidth	F271
		Jump Frequency 2	F272
		Jump Frequency 2 Bandwidth	F273

Program Mode Menu Navigation			
Primary Menu	Sub Menu	Parameter Name	Parameter Number
SPECIAL	Jump Frequencies	Jump Frequency 3	F274
		Jump Frequency 3 Bandwidth	F275
	Operation Panel Parameters	Operation Command Clear Selection With Standby Terminal Off	F719
		Panel Stop Pattern	F721
		Panel Torque Command	F725
		Panel Tension Torque Bias	F727
		Panel Load Sharing Gain	F728
		Panel Override Multiplication Gain	F729
		Panel Frequency Lockout	F730
		Panel Emergency Off Lockout	F734
		Panel Reset Lockout	F735
	Traverse	Traverse Selection	F980
		Traverse Acceleration Time	F981
		Traverse Deceleration Time	F982
		Traverse Step	F983
		Traverse Jump Step	F984
	MOTOR	Motor Set 2	Motor Set 2 Base Frequency
Motor Set 2 Base Frequency Voltage			F171
Motor Set 2 Manual Torque Boost			F172
Motor Set 2 Overload Protection Level			F173
Motor Set 3		Motor Set 3 Base Frequency	F174
		Motor Set 3 Base Frequency Voltage	F175
		Motor Set 3 Manual Torque Boost	F176
		Motor Set 3 Overload Protection Level	F177
Motor Set 4		Motor Set 4 Base Frequency	F178
		Motor Set 4 Base Frequency Voltage	F179
		Motor Set #4 Manual Torque Boost	F180
		Motor Set #4 Overload Protection Level	F181
PM Motor		PM Motor Constant 1 (D-Axis Inductance)	F498
		PM Motor Constant 2 (Q-Axis Inductance)	F499

Program Mode Menu Navigation			
Primary Menu	Sub Menu	Parameter Name	Parameter Number
MOTOR	PM Motor	Step-Out Detection-Current Level (For PM Motors)	F640
		Step-Out Detection-Current Time (For PM Motors)	F641
	Vector Motor Model	Autotune 1	F400
		Slip Frequency Gain	F401
		Autotune 2	F402
		Motor Rated Capacity (Nameplate)	F405
		Motor Rated Current (Nameplate)	F406
		Motor Rated RPM (Nameplate)	F407
		Base Frequency Voltage 1	F409
		Motor Constant 1 (Torque Boost)	F410
		Motor Constant 2 (No Load Current)	F411
		Motor Constant 3 (Leak Inductance)	F412
	Motor Constant 4 (Rated Slip)	F413	
TORQUE	Manual Torque Limit Settings	Power Running Torque Limit 2 Level	F444
		Regenerative Braking Torque Limit 2 Level	F445
		Power Running Torque Limit 3 Level	F446
		Regenerative Braking Torque Limit 3 Level	F447
		Power Running Torque Limit 4 Level	F448
		Regenerative Braking Torque Limit 4 Level	F449
	Setpoints	VI/II (V/I) Input Point 1 Rate	F205
		VI/II (V/I) Input Point 2 Rate	F206
		RR Input Point 1 Rate	F214
		RR Input Point 2 Rate	F215
		RX Input Point 1 Rate	F220
		RX Input Point 2 Rate	F221
		RX2 Option (AI1) Input Point 1 Rate	F226
		RX2 Option (AI1) Input Point 2 Rate	F227
	Torque Control	Braking Mode	F341
		Torque Bias Input	F342
		Panel Torque Bias	F343
		Panel Torque Gain	F344

Program Mode Menu Navigation			
Primary Menu	Sub Menu	Parameter Name	Parameter Number
TORQUE	Torque Control	Release Time	F345
		Creeping Frequency	F346
		Creeping Time	F347
		Braking Time Learning Function	F348
		Torque Command	F420
		Tension Torque Bias Input (Torque Control)	F423
		Load Sharing Gain Input	F424
		Forward Speed Limit Input	F425
		Forward Speed Limit Input Level	F426
		Reverse Speed Limit Input	F427
		Reverse Speed Limit Input Level	F428
	Torque Limit Settings	Power Running Torque Limit 1	F440
		Power Running Torque Limit 1 Level	F441
		Regenerative Braking Torque Limit 1	F442
		Regenerative Braking Torque Limit 1 Level	F443
		Acceleration/Deceleration Operation After Torque Limit	F451
	Torque Speed Limiting	Speed Limit (Torque = 0) Center Value Reference	F430
		Speed Limit (Torque = 0) Center Value	F431
		Speed Limit (Torque = 0) Band	F432
Allow Specified Direction ONLY		F435	
FEEDBACK	Drooping Control	Drooping Gain	F320
		Speed at 0% Drooping Gain	F321
		Speed at F320 Drooping Gain	F322
		Drooping Insensitive Torque	F323
		Drooping Output Filter	F324
	Feedback Settings	PID Control Switching	F359
		PID Feedback Signal	F360
		PID Feedback Delay Filter	F361
		PID Feedback Proportional Gain	F362
		PID Feedback Integral Gain	F363

Program Mode Menu Navigation			
Primary Menu	Sub Menu	Parameter Name	Parameter Number
FEEDBACK	Feedback Settings	PID Deviation Upper-Limit	F364
		PID Deviation Lower-Limit	F365
		PID Feedback Differential Gain	F366
		Process Upper-Limit	F367
		Process Lower-Limit	F368
		PID Control Wait Time	F369
		PID Output Upper-Limit	F370
		PID Output Lower-Limit	F371
		Process Increasing Rate	F372
		Process Decreasing Rate	F373
		Speed PI Switching Frequency	F466
	Override Control	Adding Input Selection	F660
		Multiplying Input Selection	F661
	PG Settings	Number of PG Input Pulses	F375
		Number of PG Input Phases	F376
		PG Disconnection Detection	F377
		Simple Positioning Completion Range	F381
		Current Control Proportional Gain	F458
		Speed Loop Proportional Gain	F460
		Speed Loop Stabilization Coefficient	F461
		Load Moment of Inertia 1	F462
		Second Speed Loop Proportional Gain	F463
		Second Speed Loop Stabilization Coefficient	F464
Load Moment of Inertia 2		F465	
MY FUNCTION	My Function Selection	My Function Operating Mode	F977
	My Function Unit 1	Input Function Target 1	F900
		Input Function Command 1	F901
		Input Function Target 2	F902
		Input Function Command 2	F903
		Input Function Target 3	F904
		Output Function Assigned	F905

Program Mode Menu Navigation			
Primary Menu	Sub Menu	Parameter Name	Parameter Number
MY FUNCTION	My Function Unit 2	Input Function Target 1	F906
		Input Function Command 1	F907
		Input Function Target 2	F908
		Input Function Command 2	F909
		Input Function Target 3	F910
		Output Function Assigned	F911
	My Function Unit 3	Input Function Target 1	F912
		Input Function Command 1	F913
		Input Function Target 2	F914
		Input Function Command 2	F915
		Input Function Target 3	F916
		Output Function Assigned	F917
	My Function Unit 4	Input Function Target 1	F935
		Input Function Command 1	F936
		Input Function Target 2	F937
		Input Function Command 2	F938
		Input Function Target 3	F939
		Output Function Assigned	F940
	My Function Unit 5	Input Function Target 1	F941
		Input Function Command 1	F942
		Input Function Target 2	F943
		Input Function Command 2	F944
		Input Function Target 3	F945
		Output Function Assigned	F946
My Function Unit 6	Input Function Target 1	F947	
	Input Function Command 1	F948	
	Input Function Target 2	F949	
	Input Function Command 2	F950	
	Input Function Target 3	F951	
	Output Function Assigned	F952	

Program Mode Menu Navigation			
Primary Menu	Sub Menu	Parameter Name	Parameter Number
MY FUNCTION	My Function Unit 7	Input Function Target 1	F953
		Input Function Command 1	F954
		Input Function Target 2	F955
		Input Function Command 2	F956
		Input Function Target 3	F957
		Output Function Assigned	F958
	My Function Data	My Function Percent Data 1	F918
		My Function Percent Data 2	F919
		My Function Percent Data 3	F920
		My Function Percent Data 4	F921
		My Function Percent Data 5	F922
		My Function Frequency Data 1	F923
		My Function Frequency Data 2	F924
		My Function Frequency Data 3	F925
		My Function Frequency Data 4	F926
		My Function Frequency Data 5	F927
		My Function Time Data 1	F928
		My Function Time Data 2	F929
		My Function Time Data 3	F930
		My Function Time Data 4	F931
		My Function Time Data 5	F932
		My Function Count Data 1	F933
		My Function Count Data 2	F934
		My Function Analog	Analog Input Function Target 11
	Analog Function Assigned Object 11		F961
	Analog Input Function Target 21		F962
	Analog Function Assigned Object 21		F964
	My Function Monitor	Monitor Output Function 11	F965
		Monitor Output Function Command 11	F966

Program Mode Menu Navigation			
Primary Menu	Sub Menu	Parameter Name	Parameter Number
MY FUNCTION	My Function Monitor	Monitor Output Function 21	F967
		Monitor Output Function Command 21	F968
		Monitor Output Function 31	F969
		Monitor Output Function Command 31	F970
		Monitor Output Function 41	F971
		Monitor Output Function Command 41	F972
COMMUNICATIONS	Communication Adjustments	Frequency Point Selection	F810
		Point 1 Setting	F811
		Point 1 Frequency	F812
		Point 2 Setting	F813
		Point 2 Frequency	F814
	Communication Settings	RS485 2-Wire Baud Rate	F800
		RS485 2-Wire and 4-Wire Parity	F801
		ASD Number	F802
		RS485 2-Wire and 4-Wire Communications Time-Out	F803
		RS485 2-Wire and 4-Wire Communications Time-Out Action	F804
		RS485 2-Wire Send Wait Time	F805
		RS485 2-Wire ASD-to-ASD Communication	F806
		RS485 2-Wire Protocol	F807
		RS485 4-Wire Baud Rate	F820
		RS485 Send Wait Time	F825
		RS485 4-Wire ASD-to-ASD Communication	F826
		RS485 4-Wire Protocol (TSB/MODBUS)	F829
		Communication Option (DeviceNet/Profibus) Setting 1	F830
		Communication Option (DeviceNet/Profibus) Setting 2	F831
		Communication Option (DeviceNet/Profibus) Setting 3	F832
Communication Option (DeviceNet/Profibus) Setting 4	F833		
Communication Option (DeviceNet/Profibus) Setting 5	F834		
Communication Option (DeviceNet/Profibus) Setting 6	F835		
Communication Option (DeviceNet/Profibus) Setting 7	F836		

Program Mode Menu Navigation			
Primary Menu	Sub Menu	Parameter Name	Parameter Number
COMMUNICATIONS	Communication Settings	Communication Option (DeviceNet/Profibus) Setting 8	F841
		Communication Option (DeviceNet/Profibus) Setting 9	F842
		Communication Option (DeviceNet/Profibus) Setting 10	F843
		Communication Option (DeviceNet/Profibus) Setting 11	F844
		Communication Option (DeviceNet/Profibus) Setting 12	F845
		Communication Option (DeviceNet/Profibus) Setting 13	F846
		Disconnection Detection Extended Time	F850
		ASD Operation at Disconnection	F851
		Preset Speed Operation	F852
		Communication Option Station Address Monitor	F853
		Communication Option Speed Switch Monitor DeviceNet/CC-Link	F854
		Block Write Data 1	F870
		Block Write Data 2	F871
		Block Read Data 1	F875
		Block Read Data 2	F876
		Block Read Data 3	F877
		Block Read Data 4	F878
		Block Read Data 5	F879
	Free Notes	F880	
	Network Option Reset Setting	F899	
Ethernet Settings	IP	N/A	
	Sub Net		
	Gateway		
	DHCP Mode		
	MAC ID		
PATTERN RUN	Operation Mode	Preset Speed Operation Mode	F560
		Preset Speed 1	F561
		Direction	
		Acc/Dec Group	

Program Mode Menu Navigation			
Primary Menu	Sub Menu	Parameter Name	Parameter Number
PATTERN RUN	Operation Mode	V/f Group	F561
		Torque Limit Group	
		Preset Speed 2	F562
		Direction	
		Acc/Dec Group	
		V/f Group	
		Torque Limit Group	
		Preset Speed 3	F563
		Direction	
		Acc/Dec Group	
		V/f Group	
		Torque Limit Group	
		Preset Speed 4	F564
		Direction	
		Acc/Dec Group	
		V/f Group	
		Torque Limit Group	
		Preset Speed 5	F565
		Direction	
		Acc/Dec Group	
		V/f Group	
		Torque Limit Group	
		Preset Speed 6	F566
		Direction	
		Acc/Dec Group	
		V/f Group	
		Torque Limit Group	
		Preset Speed 7	F567
		Direction	
		Acc/Dec Group	

Program Mode Menu Navigation			
Primary Menu	Sub Menu	Parameter Name	Parameter Number
PATTERN RUN	Operation Mode	V/f Group	F567
		Torque Limit Group	
		Preset Speed 8	F568
		Direction	
		Acc/Dec Group	
		V/f Group	
		Torque Limit Group	
		Preset Speed 9	F569
		Direction	
		Acc/Dec Group	
		V/f Group	
		Torque Limit Group	
		Preset Speed 10	F570
		Direction	
		Acc/Dec Group	
		V/f Group	
		Torque Limit Group	
		Preset Speed 11	F571
		Direction	
		Acc/Dec Group	
		V/f Group	
		Torque Limit Group	
		Preset Speed 12	F572
		Direction	
		Acc/Dec Group	
		V/f Group	
		Torque Limit Group	
		Preset Speed 13	F573
		Direction	
		Acc/Dec Group	

Program Mode Menu Navigation			
Primary Menu	Sub Menu	Parameter Name	Parameter Number
PATTERN RUN	Operation Mode	V/f Group	F573
		Torque Limit Group	
		Preset Speed 14	F574
		Direction	
		Acc/Dec Group	
		V/f Group	
		Torque Limit Group	
		Preset Speed 15	F575
		Direction	
		Acc/Dec Group	
		V/f Group	
		Torque Limit Group	
	Operation Time	Speed 1 Operation Time	F540
		Speed 2 Operation Time	F541
		Speed 3 Operation Time	F542
		Speed 4 Operation Time	F543
		Speed 5 Operation Time	F544
		Speed 6 Operation Time	F545
		Speed 7 Operation Time	F546
		Speed 8 Operation Time	F547
		Speed 9 Operation Time	F548
		Speed 10 Operation Time	F549
		Speed 11 Operation Time	F550
		Speed 12 Operation Time	F551
		Speed 13 Operation Time	F552
		Speed 14 Operation Time	F553
		Speed 15 Operation Time	F554
	Pattern Run	Pattern Operation	F520
		Pattern Operation Mode	F521
		Pattern 1 Repeat	F522

Program Mode Menu Navigation			
Primary Menu	Sub Menu	Parameter Name	Parameter Number
PATTERN RUN	Pattern Run	Pattern 2 Repeat	F531
	Speeds	Pattern Group 1 Selection 1	F523
		Pattern Group 1 Selection 2	F524
		Pattern Group 1 Selection 3	F525
		Pattern Group 1 Selection 4	F526
		Pattern Group 1 Selection 5	F527
		Pattern Group 1 Selection 6	F528
		Pattern Group 1 Selection 7	F529
		Pattern Group 1 Selection 8	F530
		Pattern Group 2 Selection 1	F532
		Pattern Group 2 Selection 2	F533
		Pattern Group 2 Selection 3	F534
		Pattern Group 2 Selection 4	F535
		Pattern Group 2 Selection 5	F536
		Pattern Group 2 Selection 6	F537
		Pattern Group 2 Selection 7	F538
		Pattern Group 2 Selection 8	F539
PASSWORD AND LOCKOUT	Enter Password		N/A
	Change Password	Enter New Password	N/A
	Lockouts	Reset From Trip	N/A
		Local/Remote	
		Run/Stop from EOI	
		Frequency Change From EOI	
		Monitor Screen	
Parameter Access			
Parameter Write			

System Operation

Initial Setup

Upon initial system power up, the **Startup Wizard** starts automatically. The **Startup Wizard** assists the user with the initial configuration of the input power settings and the output parameters of the **H9 ASD**.

The **Startup Wizard** may also be selected and run from the [Program](#) menu after the initial startup, if required.

The **Startup Wizard** queries the user to select one of the following items:

Run Now? ⇒ Continue on to item **1** below.

Run Next Time? ⇒ Go to [Program Mode](#).

Manually Configure? ⇒ Go to **Finish** screen and click **Finish**.

Startup Wizard Parameters

Startup Wizard parameter settings may be viewed or changed. Change the parameter setting and click **Next**. Or click **Next** without making any changes to go to the next startup parameter.

See the section titled [Startup Wizard Parameter Requirements on pg. 59](#) for further information on the **Startup Wizard** parameters.

Click **Finish** to close the **Startup Wizard** when finished.

Startup Wizard parameters are listed below.

1. The [Voltage and Frequency Rating of the Motor](#) (Must make a selection to continue or click Finish).
2. The [Upper-Limit Frequency](#).
3. The [Lower-Limit Frequency](#).
4. The [Automatic Acceleration/Deceleration Setting](#).
5. The [Acceleration Time](#).
6. The [Deceleration Time](#).
7. The [Volts per Hertz Setting](#).
8. The [Motor Current Rating](#).
9. The [Motor RPM](#).
10. The [Command Source](#).
11. The [Frequency Reference Source](#).
12. The [Display Unit](#).
13. [Wizard: Finish](#).

Startup Wizard Parameter Requirements

The **Startup Wizard** queries the user for information on the I/O signal parameters, control, and the EOI display settings of the ASD. The ASD may also be setup by directly accessing each of the startup settings via the **Program** menu or the associated **Direct Access Numbers** (see the *H9 ASD Installation and Operation Manual*).

Upon initial system power up, the **Startup Wizard** starts automatically. It may also be run from the **Program** menu after startup, if required. The user is queried to either **(1) Run Now**, **(2) Run Next Time**, or **(3) Manually Configure** the ASD.

Select **Run Now** to start the **Startup Wizard**. The wizard will assist the user with the configuration of the **H9 Adjustable Speed Drive** using the user-input screens below starting with the **Voltage and Frequency Rating of the Motor**.

Select **Run Next Time** to return to the **Program** menu. The system will default to the **Startup Wizard** on the next power up.

Select **Manually Configure** to go to the **Finish** box. Click **Finish** to return the system to the **Frequency Command** screen.

Voltage and Frequency Rating of the Motor

Motors are designed and manufactured to be operated within a specific voltage and frequency range. The voltage and frequency specifications for a given motor may be found on the nameplate of the motor. Highlight and click on the voltage and frequency of the motor being used.

Upper-Limit Frequency

This parameter sets the highest frequency that the H9 will accept as a frequency command or frequency setpoint. The H9 may output frequencies higher than the **Upper-Limit Frequency** (but, lower than the **Maximum Frequency**) when operating in the **PID Control** mode, **Torque Control** mode, or the **Vector Control** modes (sensorless or feedback).

Lower-Limit Frequency

This parameter sets the lowest frequency that the H9 will accept as a frequency command or frequency setpoint. The H9 will output frequencies lower than the **Lower-Limit Frequency** when accelerating to the lower-limit or decelerating to a stop. Frequencies below the **Lower-Limit** may be output when operating in the **PID Control** mode, **Torque Control** mode, or the **Vector Control** modes (sensorless or feedback).

Automatic Acceleration/Deceleration

When **Automatic ACC/DEC** is chosen, the H9 adjusts the acceleration and deceleration rates according to the applied load. The minimum accel/decel time may be set using **F508**. The motor and the load must be connected prior to selecting **Automatic Accel/Decel**.

Select **Manual** to allow the settings of **F009** and **F010** to control the accel/decel, respectively. The acceleration and deceleration times range from 12.5% to 800% of the programmed values for the active acceleration time.

Select **Automatic ACC Only** to allow for the acceleration rate to be controlled automatically only.

Acceleration Time

This parameter specifies the time in seconds for the output of the ASD to go from 0.0 Hz to the **Maximum Frequency** for the **1 Acceleration** profile. The **Accel/Decel Pattern** may be set using **F502**.

Deceleration Time

This parameter specifies the time in seconds for the output of the ASD to go from the **Maximum Frequency** to 0.0 Hz for the **1 Deceleration** profile. The **Accel/Decel Pattern** may be set using **F502**.

Volts per Hertz Setting

This function establishes the relationship between the output frequency and the output voltage of the ASD.

Settings:

- Constant Torque
- Voltage Decrease Curve
- Automatic Torque Boost
- Sensorless Vector Control (Speed)
- Sensorless Vector Control (Speed/Torque Switching)
- V/f 5-point Curve (Go to F190 to Configure the V/f 5-Point Settings)
- PM Drive (Permanent Magnet)
- PG Feedback Vector Control (Speed)
- PG Feedback Vector Control (Speed/Torque Switching)

Motor Current Rating

This parameter allows the user to input the full-load amperage (FLA) of the motor. This value is found on the nameplate of the motor and is used by the ASD to determine the **Thermal Overload Protection** setting for the motor.

Motor RPM

This parameter is used to input the (nameplated) rated speed of the motor.

Command Source

This selection allows the user to establish the source of the **Run** commands. Run commands are **Run**, **Stop**, **Jog**, etc.

Settings:

- Use Terminal Block
- Use EOI Keypad
- Use RS485
- Use Communication Option Board

Frequency Reference Source

This selection allows the user to establish the source of the **Frequency** command.

Settings:

- Use VI/II (V/I)
- Use RR
- Use RX
- EOI Keypad
- RS485
- Communication Option Board
- RX2 Option (AI1)
- Option V/I
- UP/DOWN Frequency
- Pulse Input (Option)
- Pulse Input (Motor CPU)
- Binary/BCD Input (Option)

Display Unit

This parameter sets the unit of measurement for current and voltage values displayed on the EOI.

Wizard: Finish

This is the final screen of the **Startup Wizard**. The basic parameters of the ASD have been set. Click **Finish** to return to the **Program** mode. Additional application-specific programming may be required.

Operation (Local)

Note: See the section titled *EOI Features* on pg. 25 for information on **Remote** operation.

To turn the motor on perform the following:

1. Connect the **CC** terminal to the **ST** terminal.
2. Press the **Mode** key until the **Frequency Command** screen is displayed. Press the **Local/Remote** key to enter the **Local** mode (green **Local** LED illuminates).
3. Turn the **Rotary Encoder** clockwise until the desired **Frequency Command** value is displayed in the **SET** field of the LCD Screen.
4. Press the **Run** key and the motor runs at the **Frequency Command** value.

Frequency Command Screen

0 ——— ——— ——— ——— 100%	
SET:	0.00 Hz 
DC Voltage:	0.00%
Output Current:	0.00%
F R ST RES S1 S2 S3 S4 OUT1 OUT2 FL	

Note: The speed of the motor may be changed while the motor is running by using the **Rotary Encoder** to change the **Frequency Command** value.

5. Press the **Stop-Reset** key to stop the motor.

Default Setting Changes

To change a default parameter setting go to the root level of the **Program** menu. Turn the **Rotary Encoder** until the desired parameter group is within the cursor block. Press the **Rotary Encoder** to select an item or to access a subgroup (repeat if required until reaching the parameter to be changed).

Press the **Rotary Encoder** to enter the **Edit** mode and the value/setting takes on the reverse video format (dark background/light text). Turn the **Rotary Encoder** to change the parameter value/setting.

Press the **Rotary Encoder** while the parameter setting is in the reverse video mode to accept the new setting or press the **ESC** key while the new parameter setting is in the reverse video mode to exit the menu without saving the change.

For a complete listing of the **Program** mode menu selections, see the section titled **Program Mode Menu Navigation** on pg. 34. **Program** menu items are listed and mapped for convenience. The **Direct Access Numbers** are listed where applicable.

The default settings may also be changed by entering the **Parameter Number** of the setting to be changed at the **Direct Access** menu (Program ⇒ Direct Access ⇒ *Applicable Parameter Number*). A listing of the **Direct Access Numbers** and a description of the associated parameter may be found in the *H9 Adjustable Speed Drive Installation and Operation Manual*.

A listing of all parameters that have been changed from the default setting may be viewed sequentially by accessing the **Changed From Default** screen (Program ⇒ Utilities ⇒ **Changed From Default**).

The **Changed From Default** feature allows the user to quickly access the parameters that are different from the factory default settings or the post-reset settings. Once the **Changed From Default** screen is displayed, the system scrolls through all of the system parameters automatically and halts once reaching a changed parameter.

Once stopped at a changed parameter, the **Rotary Encoder** may be clicked once clockwise to continue scrolling forward or clicked once counterclockwise to begin scrolling in reverse. With each click of the **Rotary Encoder** from a stop, the system scrolls through the parameters and stops at the next parameter that has been changed.

Press the **Rotary Encoder** while stopped at a changed parameter to display the settings of the changed parameter. Press the **Rotary Encoder** to enter the **Edit** mode — the parameter value/setting takes on the reverse video format (dark background/light text). Turn the **Rotary Encoder** to change the parameter setting.

Press the **ESC** key while the setting is in the reverse video format to exit the **Edit** mode without saving the change and to resume the **Changed From Default** search. Or press the **Rotary Encoder** while the setting is in the reverse video format to save the change. Press **ESC** to return to the **Changed From Default** search.

Pressing **ESC** while the system is performing a **Changed From Default** search terminates the search. Pressing **ESC** when finished searching (or halted at a changed parameter) takes the menu back one level.

Note: *Communications setting changes will require that the power be removed and then re-applied for the changes to take affect.*

Note: *Parameter F201 was changed to create the example shown in Figure 26.*

Figure 26. Changed From Default Screen.

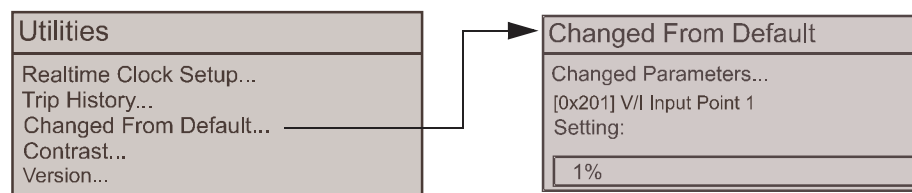

Save User Settings

A profile of an existing setup may be saved and re-applied when required by using the **Save User Setup** feature. This function is carried out via Program ⇒ Utilities ⇒ Type Reset ⇒ **Save User Settings**.

With the initial setup saved, troubleshooting and diagnostics may be performed and the starting setup may be re-applied when finished via Program ⇒ Utilities ⇒ Type Reset ⇒ **Restore User Settings**.

Note: *EOI settings are not stored using the **Save User Settings** or the **Restore User Settings** feature (i.e., contrast setting, voltage/current units, display gradient characteristics, etc.).*

Enclosure Dimensions and Conduit Plate Information

The H9 ASD part numbering convention is shown below. Use this information for ordering and to identify the ASD typeform.

The enclosure dimensions for the available models (typeforms) are listed in [Tables 3 and 4](#). The conduit plates referenced are shown in [Figures 30, 31, and 32](#).

H9 Part Numbering Convention.

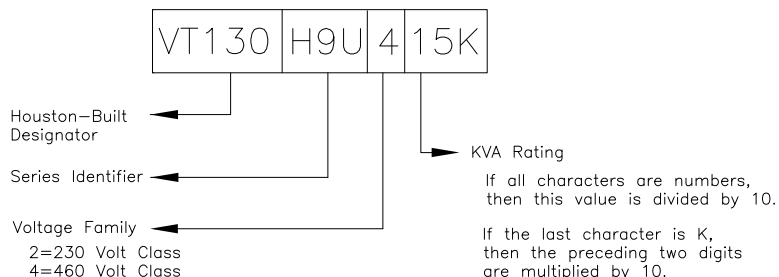

Note: The Type 1 enclosed versions of these drives meet or exceed the specification **UL 50-1995, the Standard for Heating and Cooling Equipment**, and complies with the applicable requirements for installation in a compartment handling conditioned air.

Note: All Toshiba ASD enclosures carry an IP20 rating.

Enclosure Dimensions

Table 3. 230-Volt H9 ASD Systems.

Frame	Model Number VT130H9U	Enclosure Figure Number	A Width (in/mm)	B Height (in/mm)	C Depth (in/mm)	Mounting Hole Dimensions (in/mm)				Conduit Plate
						D	E	R1	R2	
3	2035	Figure 27	6.1/155	12.4/315	6.6/168	9.8/249	5.4/138	0.098/2.5	0.217/5.5	Figure 30-A
	2055									
4	2080		6.9/175	15.0/381		11.1/283	6.2/158		0.236/6.0	Figure 30-B
	2110									
5B	2160		9.1/231	19.3/490	7.6/193	15.2/386	8.3/210	0.118/3.0	0.276/7.0	Figure 30-D
	2220									
	2270									
6	2330	Figure 28	11.1/283	25.9/658	13.2/335	25.0/635	8.0/203	0.188/4.8	0.375/9.5	Figure 30-E
7B	2400		14.3/363	33.1/841	15.0/381	32.3/820				Figure 31-G
	2500									
	2600									
	2750									
9	210K	Figure 29	14.6/371	51.7/1313	17.6/447	50.2/1275	9.2/234	0.344/8.7	0.670/17	Figure 31-I
10	212K		15.7/399	53.1/1349		51.7/1313	9.9/252			Figure 31-J

Table 4. 460-Volt H9 ASD Systems.

Frame	Model Number VT130H9U	Enclosure Figure Number	A Width (in/mm)	B Height (in/mm)	C Depth (in/mm)	Mounting Hole Dimensions (in/mm)				Conduit Plate	
						D	E	R1	R2		
3	4055	Figure 27	6.1/155	12.4/315	6.6/168	9.8/249	5.4/138	0.098/2.5	0.217/5.5	Figure 30-A	
	4080										
4	4110		6.9/175	15.0/381			6.2/158		0.236/6.0	Figure 30-B	
5A	4160		8.3/211	15.1/384	7.6/193	11.1/283	7.5/190	0.118/3.0	0.276/7.0	Figure 30-C	
	4220										
5B	4270		9.1/231	19.3/490		15.2/386	8.3/210			Figure 30-D	
	4330										
6	4400	Figure 28	11.1/283	25.9/658	13.2/335	25.0/635	8.0/203	0.188/4.8	0.375/9.5	Figure 30-E	
7A	4500			30.8/782	14.3/363	29.7/754					
	4600										
8	4750		14.3/363	36.1/917	15.3/389	35.3/897					Figure 31-H
	410K										
	412K										
9	415K	Figure 29	14.6/371	51.7/1313	17.6/447	50.2/1275	9.2/234	0.344/8.7	0.670/17	Figure 31-I	
10	420K		15.7/399	53.1/1349		51.7/1313	9.9/252			Figure 31-J	
11	425K		15.0/381	63.1/1603		61.6/1565				Figure 31-K	
12	430K		18.9/480	68.5/1740		67.0/1701	13.8/351			Figure 32-L	
	435K										
13	440K		25.6/650	70.0/1778			68.5/1740			21.3/541	

Figure 27. See Tables 3 and 4 for Actual Dimensions.

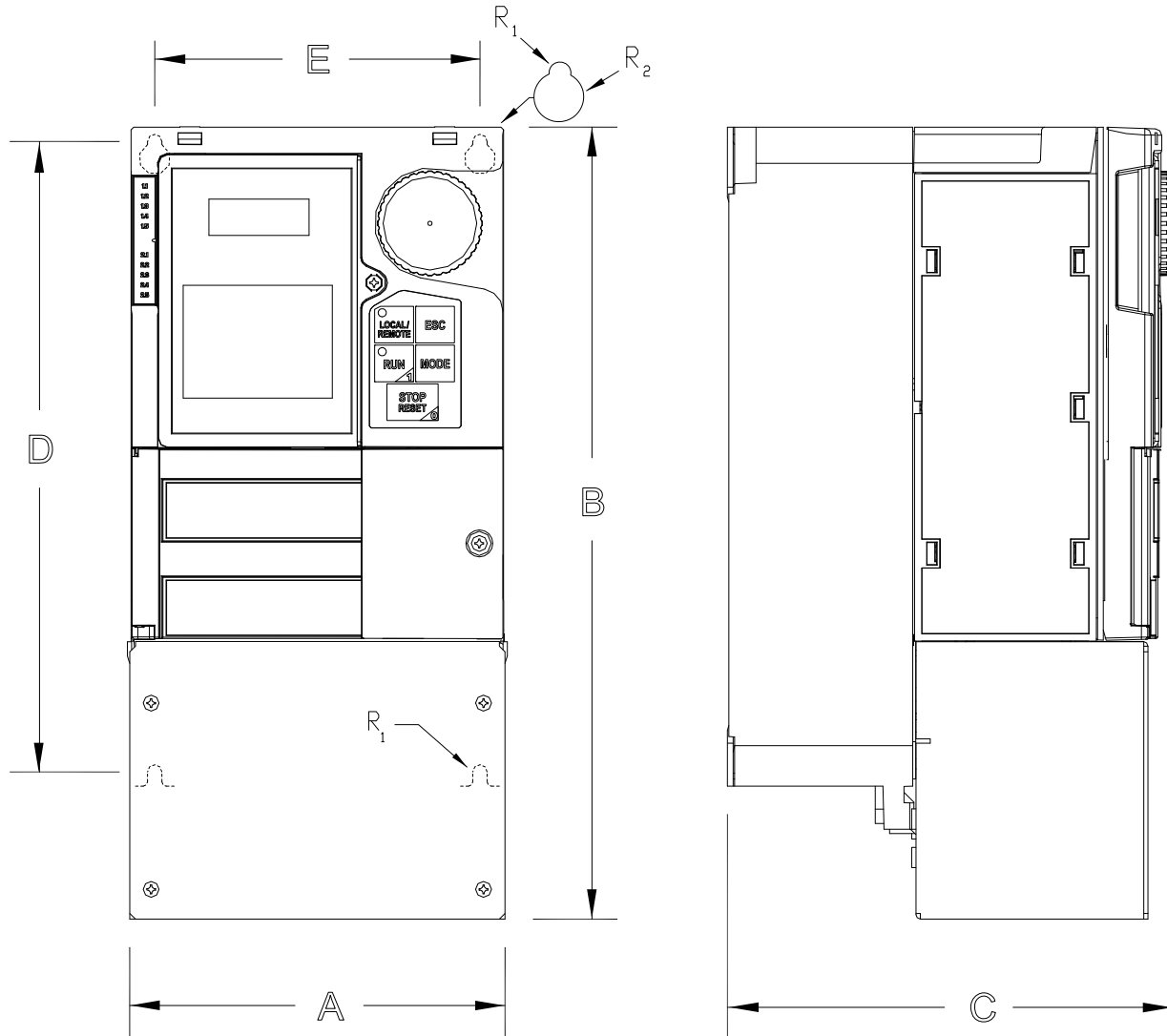

Figure 28. See Tables 3 and 4 for Actual Dimensions.

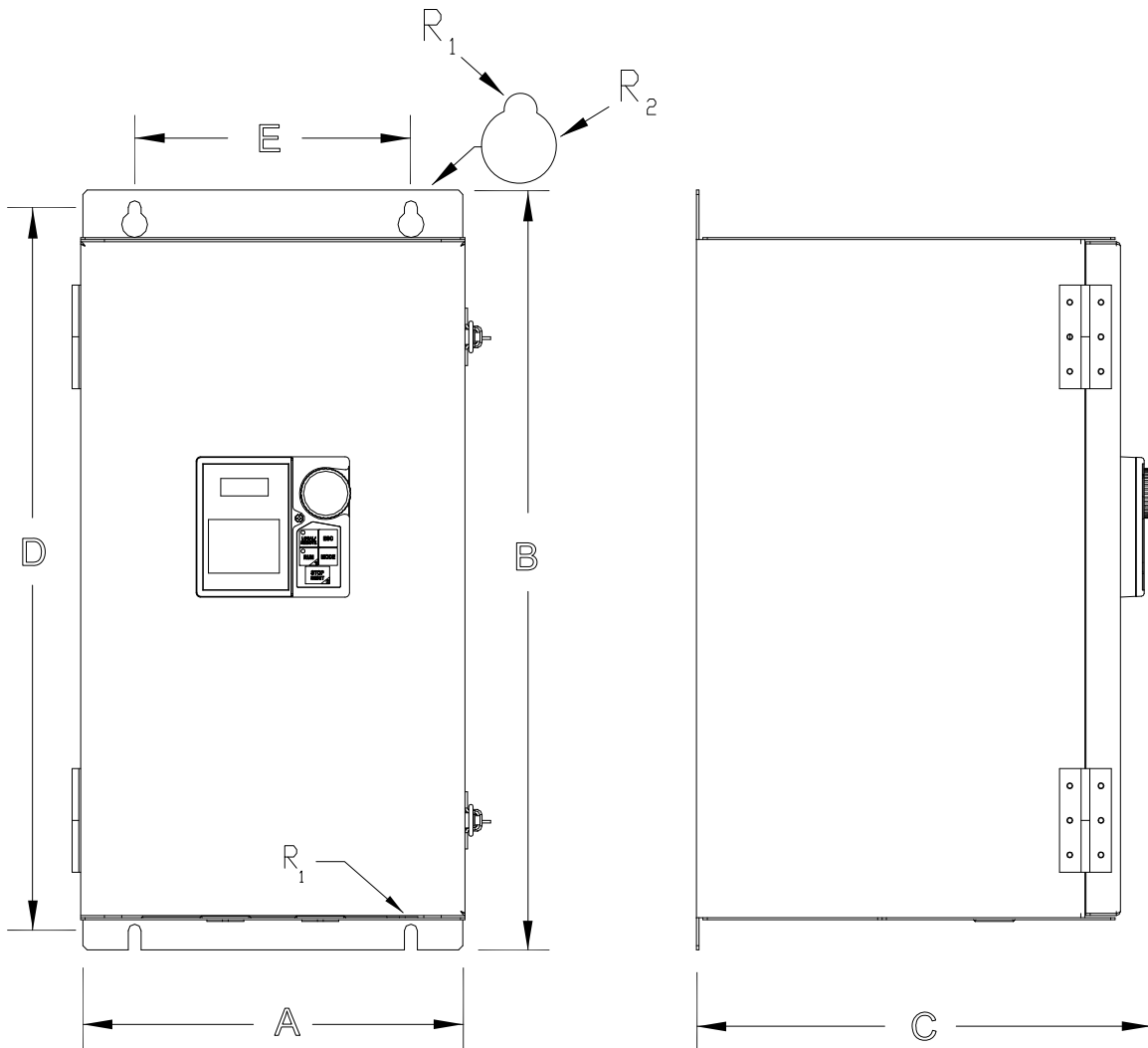
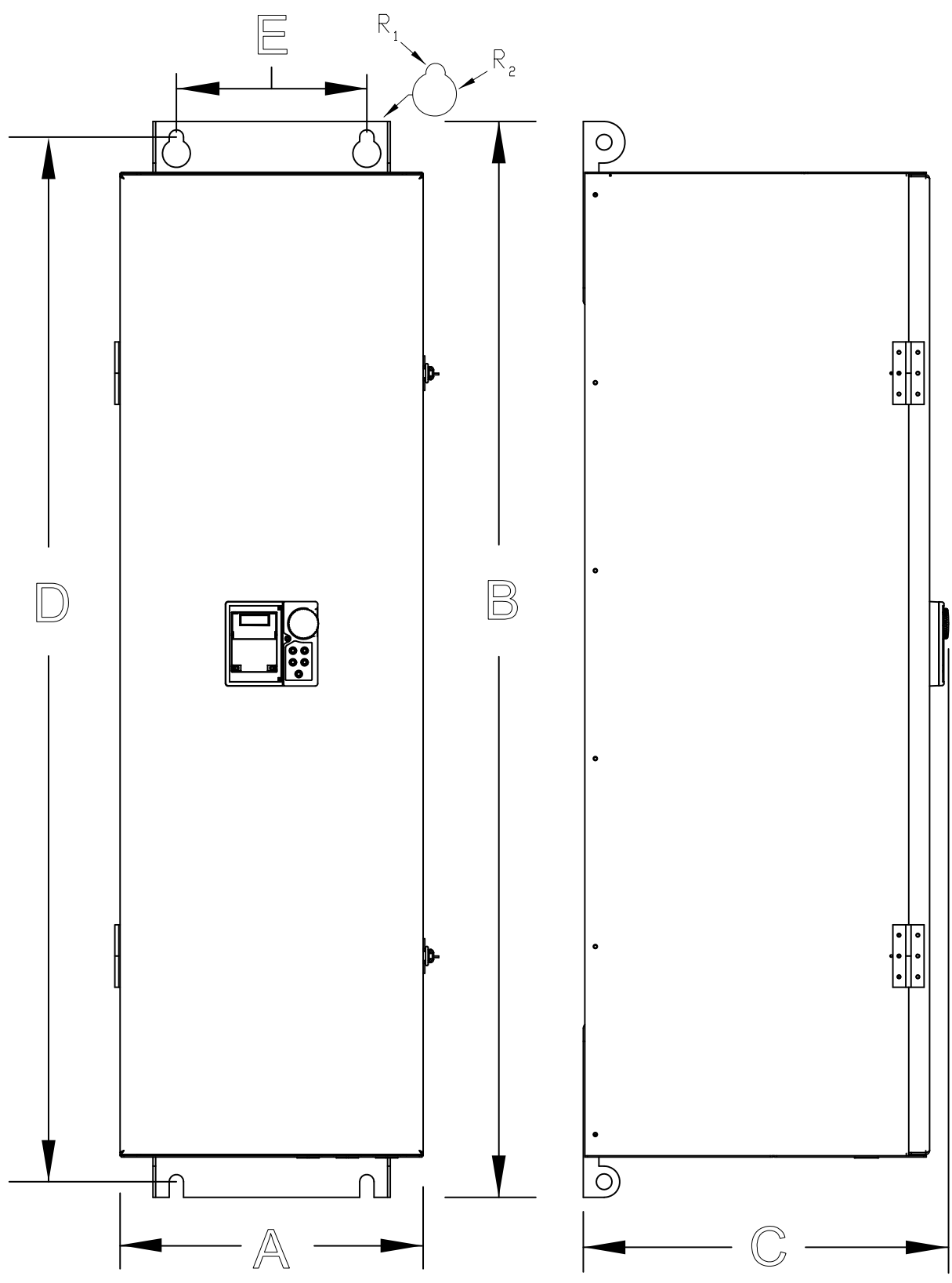

Figure 29. See Tables 3 and 4 for Actual Dimensions.



Conduit Plate Dimensions

Figure 30. See Tables 3 and 4 for the associated device. Dimensions are in in/cm.

ØX = Concentric Knockouts for Diameter Sizes 0.5", 0.75", and 1.0" Conduit.

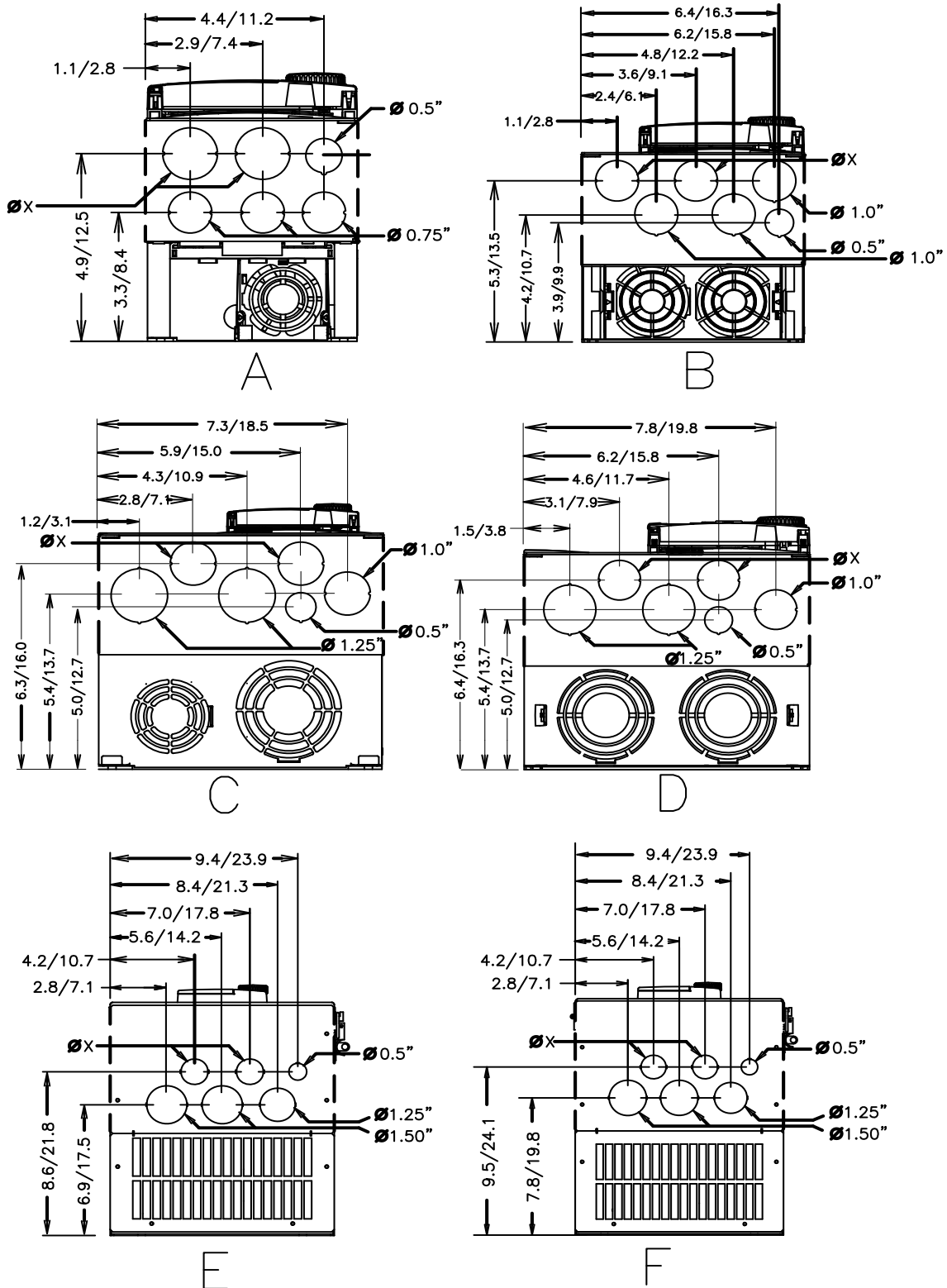

Figure 31. See Tables 3 and 4 for the associated device. Dimensions are in in/cm.

ØX = Concentric Knockouts for Diameter Sizes 0.5", 0.75", and 1.0" Conduit.

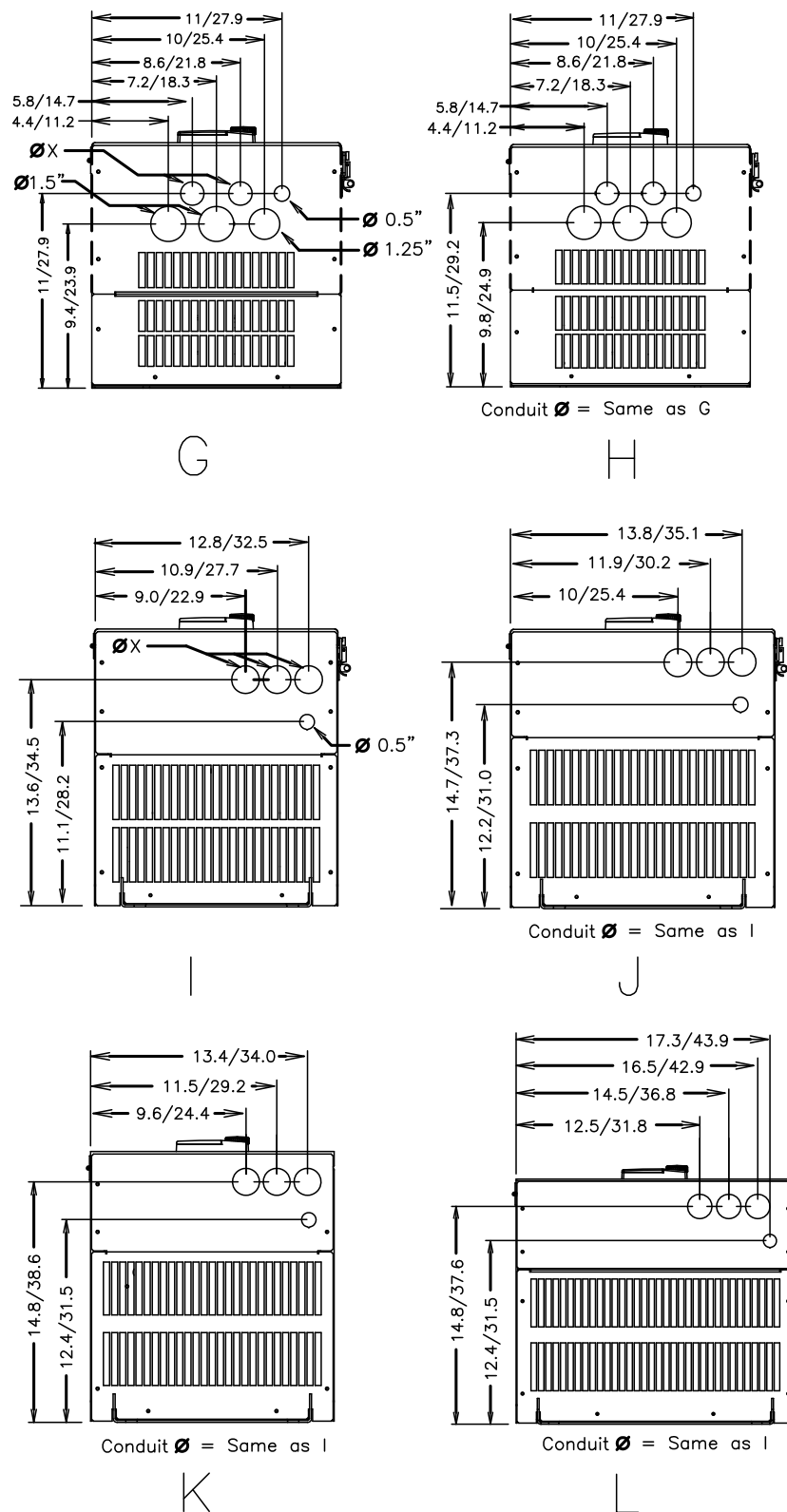
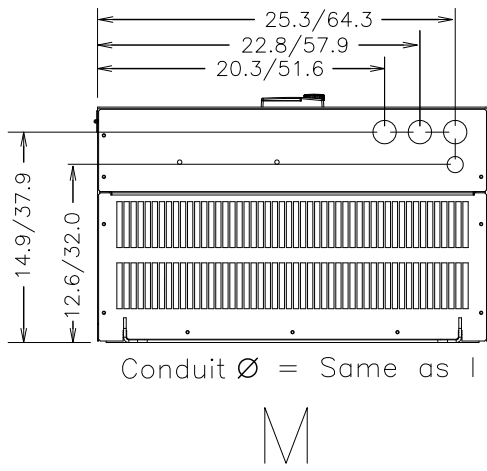

Figure 32. See Table 4 for the associated device. Dimensions are in in/cm.



Voltage/Current Specifications

Table 5. 230-Volt UL Type-1/IP-20 Chassis Standard Ratings Table.

Model Number VT130H9U	100% Output Current Continuous	Overload Current 120% for 60 Seconds	Input Voltage 3-Ph 50/60 ±2 Hz	Output Voltage 3-Ph Variable Frequency	Typical Motor HP
2035	9.6 A	11.5 A	200–240 VAC (±10%)	Input Voltage Level (Max.)	3.0
2055	15.2 A	18.2 A			5.0
2080	22 A	26 A			7.5
2110	28 A	34 A			10
2160	42 A	50 A			15
2220	54 A	65 A			20
2270	68 A	82 A			25
2330	80 A	96 A			30
2400	104 A	125 A			40
2500	130 A	156 A			50
2600	154 A	185 A			60
2750	192 A	230 A			75
210K	248 A	298 A			100
212K	312 A	374 A			125

Table 6. 460-Volt UL Type-1/IP-20 Chassis Standard Ratings Table.

Model Number VT130H9U	100% Output Current Continuous	Overload Current 120% for 60 Seconds	Input Voltage 3-Ph 50/60 ± 2 Hz	Output Voltage 3-Ph Variable Frequency	Typical Motor HP
4055	7.6 A	9.0 A	380 – 480 VAC (±10%)	Input Voltage Level (Max.)	5.0
4080	11 A	13 A			7.5
4110	14 A	17 A			10
4160	21 A	25 A			15
4220	27 A	32 A			20
4270	34 A	41 A			25
4330	40 A	48 A			30
4400	52 A	62 A			40
4500	65 A	78 A			50
4600	77 A	92 A			60
4750	96 A	115 A			75
410K	124 A	149 A			100
412K	156 A	187 A			125
415K	180 A	216 A			150
420K	240 A	288 A			200
425K	302 A	362 A			250
430K	361 A	433 A			300
435K	414 A	497 A			350
440K	477 A	572 A			400

Cable/Terminal/Torque Specifications

Installation should conform to the 2008 National Electrical Code Article 110 (NEC) (Requirements for Electrical Installations), all regulations of the Occupational Safety and Health Administration, and any other applicable national, regional, or industry codes and standards.

Note: The following ratings are guidelines and shall not be the sole determining factor of the lug or wire size used with the H9 ASD. Application-specific applicables, wire insulation type, conductor material, and local and regional regulations are but a few of the considerations when selecting the actual lug and wire type to be used with the H9 ASD.

Note: Cable/Terminal specifications are based on the rated current of the H9 ASD and **Do Not** include the 10% Service Factor.

Note: Use only 75° C copper wire/cable for motor and power connections.

For further installation information see the section titled [Installation and Connections](#) on pg. 10.

Table 7. 230-Volt H9 ASD Cable/Terminal/Torque Specifications.

Model Number VT130H9U	MCP Rating (Amps)	Wire/Cable Size		Lug Size Range		Terminal Board	Torque		
		AWG or kcmil						3Ø-Input	3Ø-Output
		Input/Output Power		Wire-Size/Lug-Capacity for Input/Output Power		TB1 – 4 Terminals	In-Lbs./Nm		
		Recommended	Maximum	3Ø-Input	3Ø-Output				
2035	30	14	10	14 to 8		20 (3-core shield) 5.3/0.6	11.5/1.3		
2055		10							
2080	50	8	8	12 to 8			17.7/2.0		
2110									
2160	75	6	3	8 to 3			21/2.4		
2220	100	4							
2270	125	3							
2330	150	2	2	12 to 1/0	4 to 1/0		50/5.7	53/6	
2400	175	1/0	4/0	6 to 250	2 to 300		275/31	168/19	
2500	200	2/0							
2600	250	3/0							
2750	300	4/0							
210K	400	*3/0	*1/0	6 to 250		275/31			
212K	500	*250	*250						

Note: (*) Indicates that the item is one of a set of two parallel cables.

Table 8. 460-Volt H9 ASD Cable/Terminal/Torque Specifications.

Model Number VT130H9U	MCP Rating (Amps)	Wire/Cable Size		Lug Size Range		Terminal Board	Torque		
		AWG or kcmil						3Ø-Input	3Ø-Output
		Input/Output Power		Wire-Size/Lug-Capacity for Input/Output Power		TB1 – 4 Terminals			
		Recommended	Maximum	3Ø-Input	3Ø-Output	In-Lbs./Nm			
4055	15	14	10	14 to 8		20 (3-core shield) Torque to 5.3/0.6	11.5/1.3		
4080	20	12		12 to 8			17.7/2.0		
4110	30	10	8	10 to 4			21/2.4		
4160		8	4						
4220	50	4	3	8 to 3					
4270	75								
4330	100	3	2	12 to 1/0	4 to 1/0		50/5.7	53/6.0	
4400				4600	125		2	4/0	6 to 250
4500	175	1/0							
4600	200	2/0	*4/0	6 to 250			275/31		
4750	250	4/0							
410K	300	*1/0							
412K	400	*3/0	*250	4 to 350		375/42.4			
415K	500	*250							
420K	600	*300	*350	0 to 500	6 to 350				
425K	700	*350							
430K	800	**250	**350						

Note: (*) Indicates that the item is one of a set of two parallel cables.

Note: (**) Indicates that the item is one of a set of three parallel cables.

Short Circuit Protection Recommendations

Table 9. 230/240 and 400/480-Volt ASD Recommended Circuit Breaker Selection.

Model Number VT130H9U	HP	Continuous Output Current (Amps)	Circuit Breaker Part Number
2035	3.0	10.0	HLL36025
2055	5.0	17.5	
2080	7.5	27.5	HLL36040
2110	10	33.0	HLL36050
2160	15	54.0	HLL36070
2220	20	66.0	HLL36090
2270	25	76.0	HLL36100
2330	30	90.0	
2400	40	120	HLL36125
2500	50	152	HLL36150
2600	60	176	JLL36200
2750	75	221	
210K	100	285	JLL36250
212K	125	365	LIL36300
4055	5	10.5	HLL36025
4080	7.5	14.3	HLL36040
4110	10	17.6	HLL36050
4160	15	27.7	HLL36070
4220	20	33.0	HLL36090
4270	25	41.0	HLL36100
4330	30	48.0	
4400	40	66.0	HLL36125
4500	50	79.0	HLL36150
4600	60	94.0	JLL36200
4750	75	116	JLL36225
410K	100	160	JLL36250
412K	125	179	LIL36300
415K	150	215	
420K	200	259	LIL36400
425K	250	314	
430K	300	387	LIL36450
435K	350	434	LIL36500
440K	400	495	Consult NEC

Dynamic Braking Resistor Wire/Cable Specifications

Thermal protection for the DBR circuit (see on pg. 78) or an input contactor that will open the input 3-phase power circuit (see Figure 34. on pg. 78) to the H9 ASD in the event that a DBR over-temperature condition occurs is a requirement. If a DBR failure occurs or should a power source over-voltage condition occur the DBR thermal protection circuitry will prevent hazardous DBR temperatures.

To use the **Dynamic Braking** function the following requirements must be met:

- **Enable** the DBR function,
- Selected a **Resistance Value**, and
- Set the **Continuous Braking Wattage** value at **F304**, **F308**, and **F309**, respectively.

Set the **Braking Resistance Overload Time** at parameter **F639** to establish how long the braking resistor is allowed to sustain the overload condition before a trip is incurred (the factory default setting is 5 seconds).

Light-duty and heavy-duty resistors vary from a few ohms to several hundred ohms. The appropriate resistance size will be typeform- and application-specific. Contact your Toshiba Sales Representative or the Toshiba Customer Service Department for more information on your specific DBR requirements.

Heavy duty DBRs should be wired using the same gauge wire as the motor leads. Light duty DBRs may use one wire size smaller (AWG or kcmil) than the motor leads.

Because the heat generated by the DBR will affect the cooling capacity of the heat sink, the resistor pack should be mounted above or to the side of the ASD — **Never below the ASD**. Maintain a minimum of six inches between the resistor pack and the ASD unit.

The total wire length from the ASD to the DBR should not exceed ten feet.

The wiring from the ASD to the DBR should be twisted approximately two twists per foot throughout the length of the wire.

If EMI/RFI noise is of concern, the DBR wiring should be three-core screened cable. The screen should connect to the ASD enclosure and the resistor enclosure.

CAUTION

Though the in-line DBR fuse and the thermal relay are designed into the system to prevent a catastrophic DBR over-current condition, they are both intended to be used as backup protection **ONLY**.

A proper typeform-specific and application-specific system setup that includes using the appropriate **Dynamic Braking Resistor and Overload** settings will be required.

Figure 33. Braking Resistor Circuit with a Thermal Fuse.

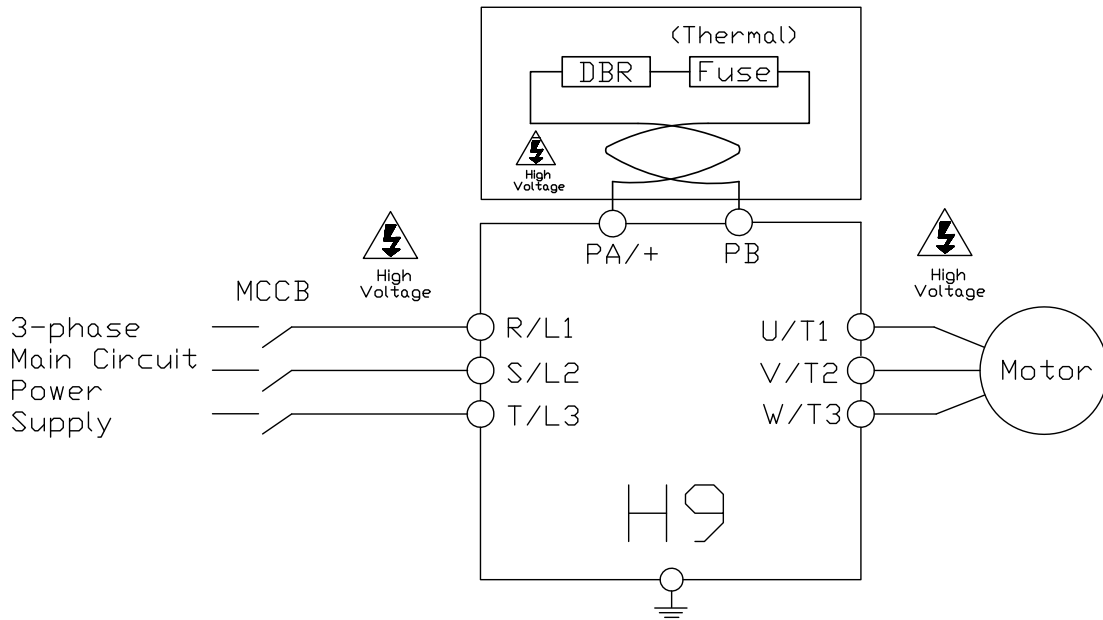
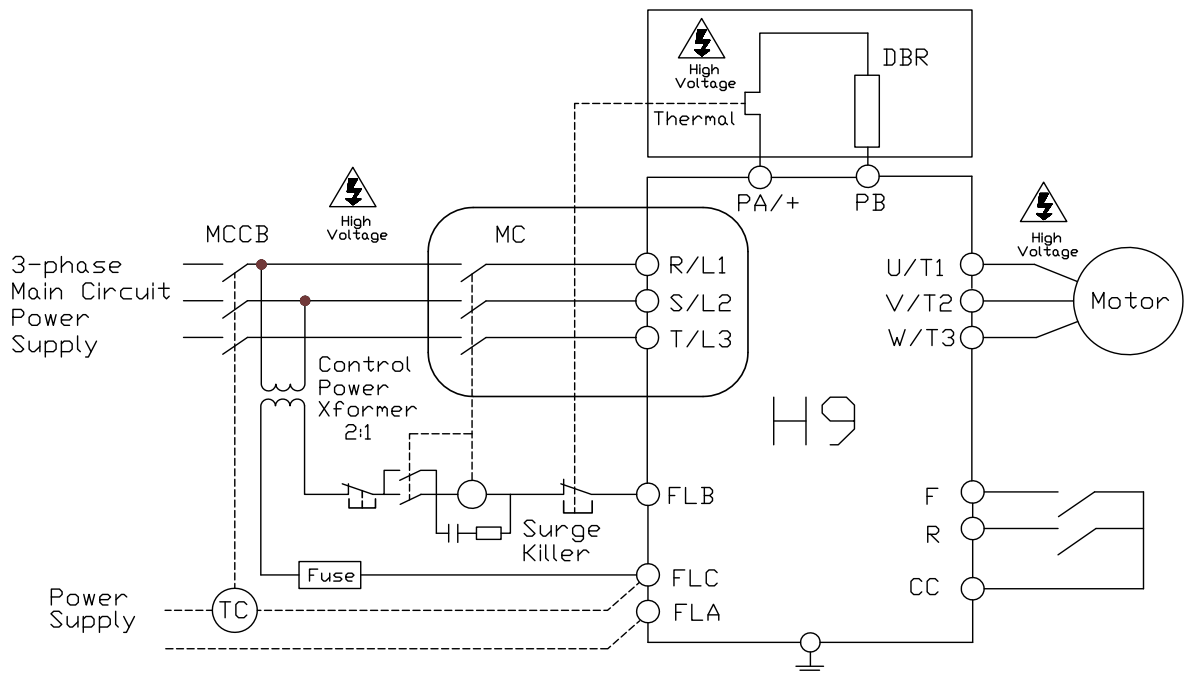

Figure 34. Shown below is the connection diagram using an MCCB with a Trip Coil (TC) in lieu of an input contactor. A control transformer is required for 400-volt models only. The primary MC is



Index

A

Abnormal Speed Settings, 40
 Acc/Dec 1 – 4 Settings, 44
 Acc/Dec Special, 44
 Accel/Decel 1 Settings, 34
 Alarm Prohibition, 38
 AM, 17, 19
 AM Output, 31
 AM/FM Output, 21
 Analog Filter, 42
 Analog Output Terminals, 35
 ASD Load, 31
 ASD OL (Overload) Trip, 31
 ASD Overload, 31
 Auto Accel/Decel, 59

B

Base Frequency Voltage, 40

C

Cable/Terminal Specifications, 74
 Carrier Frequency, 44
 CC, 17
 CCA, 17
 Changed From Default, 39, 62
 Charge LED, 9, 12
 Circuit Breaker Configuration, 11
 Clock Setup, 38
 Command Source, 60
 Communication Adjustments, 52
 Communication Settings, 52
 Communications, 52
 Communications Setting Changes, 62
 Compensation Frequency, 31
 Conduit Plate Dimensions, 64
 Connecting the ASD, 12
 Connection Diagram, 22
 Contrast, 39
 Crane/Hoist Settings, 44
 Current/Voltage Specifications, 72
 Customer Support, 2

D

DBR Load, 32
 DBR OL (Overload) Trip, 31
 DBR Over-Current, 78
 DBR Overload, 31
 DC Bus Voltage, 31
 DC Injection Braking, 40
 Default Setting Changes, 62
 Direct Access, 37
 Direction, 33
 Discrete Input, 17, 21
 Discrete Input Terminals, 33
 Display Parameters, 37
 Disposal, 3
 Drooping Control, 48
 Dynamic Braking, 40

E

Electronic Operator Interface, 24
 Electronic Operator Interface Features, 25
 Emergency Off, 26
 Emergency Off Settings, 40
 Enclosure Dimensions, 64
 EOI Command Screen, 30
 EOI Operation, 24
 EOI Remote Mounting, 24
 Equipment Inspection, 3
 ESC Key, 25
 Excitation Current, 32

F

F, 17, 18
 Fault Relay (Shown Not Faulted), 21
 Feedback, 48
 Feedback (1 Second), 32
 Feedback (inst), 32
 Feedback Settings, 48
 FLA, 17, 20
 FLA, B, and C Switching Relationship, 20
 FLB, 17, 20
 FLC, 17, 20
 FM, 17
 FM Output, 31
 Forward/Reverse Disable, 42

FP, 17, 19
 FP Output, 21
 Frequency, 42
 Frequency at Trip, 31
 Frequency Command Mode, 29
 Frequency Command Screen, 27, 61
 Frequency Control, 45
 Frequency Reference, 31
 Frequency Reference Source, 61
 Frequency Setting, 29
 Frequency Settings, 34
 Fundamental, 34

G

General Safety Information, 1

H

Handling and Storage, 3

I

I/O and Control, 17
 I/O Circuit Configurations, 21
 IICC, 17, 22
 Important Notice, 2
 Initial Setup, 58
 Input Power, 32
 Input Special Functions, 35
 Input Terminal Delays, 35
 Input Terminals, 36
 Installation and Connections, 10
 Installation Notes, 10
 Installation Precautions, 4

J

Jog Settings, 42
 Jump Frequencies, 45

L

Lead Length Specifications, 16
 LED Character/Font Information, 26
 LED Screen, 25
 LED/LCD Screen, 26
 LED/LCD Screen Information, 26
 Line Power Switching, 36
 Local Mode, 25

Local/Remote Key, 25
 Lockout, 57
 Low-Current Settings, 40
 Lower-Limit Frequency, 59
 Lug Size, 74, 75

M

Main Monitor Selections, 33
 Manual Torque Limit Settings, 47
 MCP Rating, 74, 75
 Mode Key, 25
 Monitor Mode, 31
 Monitor Screen, 27
 Motor, 46
 Motor Connection Diagram, 13
 Motor Current Rating, 60
 Motor Load, 31
 Motor OL (Overload) Trip, 31
 Motor Overload Real, 31
 Motor Set 1, 34
 Motor Set 2, 46
 Motor Set 3, 46
 Motor Set 4, 46
 Mounting the ASD, 11

O

O1A/B, 17
 O2A/B, 19
 Operation (Local), 61
 Operation Mode, 53
 Operation Panel Parameters, 46
 Operational and Maintenance Precautions, 9
 OUT1, 17, 19
 OUT1 OUT2 FL, 33
 OUT1/OUT2 Output, 21
 OUT2, 19
 Output Current, 31
 Output Disconnect, 8
 Output Power, 32
 Output Terminals, 37
 Output Voltage, 31
 Overload, 40, 41
 Override Control, 49
 Over-Torque Parameters, 41

P

P24, 17, 19
 P24 Output, 21
 PA/+, 12

Part Numbering Convention, 64
 Password, 57
 Past Trip 1, 33
 Past Trip 2, 33
 Past Trip 3, 33
 Past Trip 4, 33
 Pattern Group Cycle, 32
 Pattern Group Number, 32
 Pattern Group Preset, 32
 Pattern Run, 53
 Pattern Time, 32
 PC/-, 12
 PG Settings, 49
 Phase Loss, 41
 PID Feedback, 32
 PO, 12
 Power Connections, 12
 PP, 17, 19
 PP Output, 21
 Preset Speeds, 42
 Primary Menus, 27
 Program Menu, 27
 Program Mode Menu Navigation, 34
 Prohibition, 37
 Protection, 40

Q

Qualified Personnel, 2

R

R, 17, 18
 R/L1, 12
 Reach Settings, 37
 Real-Time Clock Setup, 38
 Remote Mode, 25
 RES, 17, 18
 Reset, 38
 Restore User Settings, 63
 Retry/Restart, 41
 Root Menu Mapping, 29
 Root Menus, 29
 Rotary Encoder, 25
 RR, 17, 18, 32
 RR Input, 21
 Run Key, 25
 Run Time, 31
 RX, 17, 19, 32
 RX Input, 21
 RX2, 32

S

S/L2, 12
 S1, 17, 18
 S2, 17, 18
 S3, 17, 18
 S4, 17, 18
 Save User Settings, 63
 Setpoints, 47
 Short Circuit Protection, 76
 Sink, 20
 Source, 20
 Special, 44
 Special Parameters, 45
 Special Protection Parameters, 41
 Speed Reference Setpoints, 43, 44
 ST, 17, 18
 Stall, 41
 Standard Mode Selection, 34
 Startup and Test, 23
 Startup Wizard Parameter Requirements, 59
 Stop-Reset Key, 26
 SU+, 17, 19
 System Grounding, 14
 System Integration Precautions, 7
 System Operation, 58

T

T/L3, 12
 Terminal, 35
 Terminal Board, 17, 20
 Terminal Descriptions, 18
 Torque, 32, 47
 Torque Control, 47, 48
 Torque Current, 32
 Torque Limit Settings, 48
 Torque Reference, 32
 Torque Speed Limiting, 48
 Trace, 37, 38
 Traverse, 46
 Trip Code, 32
 Trip History (read-only), 38, 39
 Trip Settings, 41
 Type Reset, 38

U

U/T1, 12
 UL 1995, 64
 Under-Voltage/Ridethrough, 41
 UP/DOWN Frequency Functions, 42
 Upper-Limit Frequency, 59

Utilities, 37

V

V/I, 32, 42

V/I Isolated Input, 21

V/I Settings, 42

V/I terminal, 32

V/T2, 12

Vector Motor Model, 47

Version (read-only), 39

VI/II terminal, 32

Voltage and Frequency Rating of the Motor, 59

Volts per Hertz Setting, 60

W

W/T3, 12

Wizard Finish, 61

TOSHIBA

TOSHIBA INTERNATIONAL CORPORATION

INDUSTRIAL DIVISION

13131 West Little York Road, Houston, TX 77041

TEL: (713) 466-0277 — FAX: (713) 937-9349

Printed in the U.S.A.