

TOSHIBA

H7 Adjustable Speed Drive Operation Manual

[Toshiba H7 inverter user manual](#)

Document Number: 52854-002

Date: August, 2005

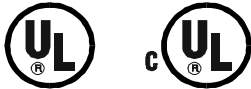

Introduction

Congratulations on the purchase of the new **H7 True Torque Control² Adjustable Speed Drive (ASD)**. The **H7 True Torque Control² Adjustable Speed Drive** is a solid-state AC drive that features **True Torque Control²**. TIC's **Vector Control Algorithm** enables the motor to develop high starting torque and provide compensation for motor slip, which results in smooth, quick starts and highly efficient operation. The H7 uses digitally-controlled pulse width modulation. The programmable functions may be accessed via the easy-to-use menu or via the **Direct Access Numbers** (see [page 60](#)). This feature, combined with Toshiba's high-performance software, delivers unparalleled motor control and reliability.

The H7 is a very powerful tool, yet surprisingly simple to operate. The user-friendly **Electronic Operator Interface (EOI)** of the H7 has an easy-to-read 240 x 64 pixel graphical LCD screen. The **EOI** provides easy access to the many monitoring and programming features of the H7.

The motor control software is menu-driven, which allows for easy access to the motor control parameters and quick changes when required.

To maximize the abilities of your new H7, a working familiarity with this manual will be required. This manual has been prepared for the **H7 ASD** installer, user, and maintenance personnel. This manual may also be used as a reference guide or for training. With this in mind, use this manual to develop a system familiarity before attempting to install or operate the device.

Important Notice

The instructions contained in this manual are not intended to cover all details or variations in equipment types, nor may it provide for every possible contingency concerning the installation, operation, or maintenance of this equipment. Should additional information be required contact your Toshiba representative.

The contents of this manual shall not become a part of or modify any prior or existing agreement, commitment, or relationship. The sales contract contains the entire obligation of Toshiba International Corporation. The warranty contained in the contract between the parties is the sole warranty of Toshiba International Corporation and any statements contained herein do not create new warranties or modify the existing warranty.

Any electrical or mechanical modifications to this equipment without prior written consent of Toshiba International Corporation will void all warranties and may void the UL/CUL listing or other safety certifications. Unauthorized modifications may also result in a safety hazard or equipment damage.

Misuse of this equipment could result in injury and equipment damage. In no event will Toshiba Corporation be responsible or liable for direct, indirect, special, or consequential damage or injury that may result from the misuse of this equipment.

About This Manual

This manual was written by the Toshiba Technical Publications Group. This group is tasked with providing technical documentation for the **H7 Adjustable Speed Drive**. Every effort has been made to provide accurate and concise information to you, our customer.

At Toshiba we're continuously searching for better ways to meet the constantly changing needs of our customers. Email your comments, questions, or concerns about this publication to the Technical-Publications-Dept@TIC.TOSHIBA.COM.

This Manual's Purpose and Scope

This manual provides information that will assist the qualified installer in the safe installation, setup, operation, and disposal of the **H7 True Torque Control² Adjustable Speed Drive**. The information provided in this manual is applicable to the **H7 True Torque Control² Adjustable Speed Drive** only.

This operation manual provides information on the various features and functions of this powerful cost-saving device, including

- Installation,
- System operation,
- Configuration and menu options, and
- Mechanical and electrical specifications.

Included is a section on general safety instructions that describe the warning labels and symbols that are used throughout the manual. Read the manual completely before installing, operating, performing maintenance, or disposing of this equipment.

This manual and the accompanying drawings should be considered a permanent part of the equipment and should be readily available for reference and review. Dimensions shown in the manual are in metric and/or the English equivalent.

Because of our commitment to continuous improvement, Toshiba International Corporation reserves the right, without prior notice, to update information, make product changes, or to discontinue any product or service identified in this publication.

Toshiba International Corporation (TIC) shall not be liable for direct, indirect, special, or consequential damages resulting from the use of the information contained within this manual.

TOSHIBA is a registered trademark of the Toshiba Corporation. All other product or trade references appearing in this manual are registered trademarks of their respective owners.

This manual is copyrighted. No part of this manual may be photocopied or reproduced in any form without the prior written consent of Toshiba International Corporation.

© Copyright 2005 Toshiba International Corporation.

All rights reserved.

Printed in the U.S.A.

Contacting Toshiba's Customer Support Center

Toshiba's Customer Support Center can be contacted to obtain help in resolving any **H7 Adjustable Speed Drive** system problem that you may experience or to provide application information.

The center is open from 8 a.m. to 5 p.m. (CST), Monday through Friday. The Support Center's toll free number is US (800) 231-1412/Fax (713) 466-8773 — Canada (800) 527-1204.

You may also contact Toshiba by writing to:

Toshiba International Corporation
13131 West Little York Road
Houston, Texas 77041-9990
Attn: ASD Product Manager.

For further information on Toshiba's products and services, please visit our website at www.tic.toshiba.com.

TOSHIBA INTERNATIONAL CORPORATION

H7 Adjustable Speed Drive

Please complete the Warranty Card supplied with the ASD and return it to Toshiba by prepaid mail. This will activate the 12 month warranty from the date of installation; but, shall not exceed 18 months from the shipping date.

Complete the following information and retain for your records.

Model Number: _____

Serial Number: _____

Project Number (if applicable): _____

Date of Installation: _____

Inspected By: _____

Name of Application: _____

Table of Contents

General Safety Information	1
Installation Precautions	5
System Integration Precautions	8
Operational and Maintenance Precautions	10
CE Compliance Requirements	11
EMC Installation Guidelines	11
General EMC Guidelines for Consideration	11
CE Compliant Installation Guidelines	11
Motor Characteristics	14
Motor Autotuning	14
Pulse Width Modulation Operation	14
Low Speed Operation	14
Overload Protection Adjustment	14
Operation Above 60 Hz	15
Power Factor Correction	15
Light Load Conditions	15
Motor/Load Combinations	15
Load-produced Negative Torque	16
Motor Braking	16
H7 ASD Characteristics	17
Overcurrent Protection	17
H7 ASD Capacity	17
Using Vector Control	17
Local/Remote Operation	17
Installation and Connections	18
Installation Notes	18
Mounting the ASD	19
Connecting the ASD	20
System Grounding	20
Power Connections	21
Lead Length Specifications	22
Startup and Test	22
I/O and Control	23
Terminal Descriptions	24
H7 ASD Control	27
CNU1/1A and CNU2/2A Pinout	28
CN3 Pinout	28
CN7 Pinout	29
I/O Circuit Configurations	30
Typical Connection Diagram	31
Electronic Operator Interface	32
EOI Features	32
EOI Operation	33

System Operation	34
Initial Setup	34
Operation (Local)	34
Default Setting Changes	35
Startup Wizard Requirements	36
Command Mode and Frequency Mode Control	39
Command Control (F003)	39
Frequency Control (F004)	40
Command and Frequency Control Selections	41
Override Operation	42
Command and Frequency-Control Override Hierarchy	42
Command Control Selections	42
Frequency Control Selections	43
System Configuration and Menu Options	44
Root Menus	44
Frequency Command Mode	44
Monitor Mode	46
Program Mode	48
Direct Access Parameter Information	60
Direct Access Parameters/Numbers	60
Alarms, Trips, and Troubleshooting	181
Alarms and Trips	181
Alarms	182
User Notification Codes	184
Trips/Faults	184
Viewing Trip Information	188
Clearing a Trip	189
Enclosure Dimensions and Conduit Plate Information	190
Enclosure Dimensions/Weight	190
Conduit Plate Information	195
Conduit Extender Box (option)	197
H7 ASD Adapter Mounting Plates	198
ASD Adapter Mounting Plate Dimensions	199
EOI Remote Mounting	202
Remote EOI Required Hardware	202
EOI Installation Precautions	202
EOI Remote Mounting w/o the ASD-MTG-KIT	203
EOI Remote Mounting using the ASD-MTG-KIT	203
Current/Voltage Specifications	205
Cable/Terminal Specifications	208
Link Reactor Information	211
H7 ASD Optional Devices	212
H7 ASD Spare Parts Listing	213

General Safety Information

DO NOT attempt to install, operate, maintain or dispose of this equipment until you have read and understood all of the product safety information and directions that are contained in this manual.

Safety Alert Symbol

The **Safety Alert Symbol** indicates that a potential personal injury hazard exists. The symbol is comprised of an equilateral triangle enclosing an exclamation mark.



Signal Words

Listed below are the signal words that are used throughout this manual followed by their descriptions and associated symbols. When the words **DANGER**, **WARNING** and **CAUTION** are used in this manual they will be followed by important safety information that must be carefully adhered to.

The word **DANGER** preceded by the safety alert symbol indicates that an imminently hazardous situation exists that, if not avoided, will result in death or serious injury to personnel.



The word **WARNING** preceded by the safety alert symbol indicates that a potentially hazardous situation exists that, if not avoided, could result in death or serious injury to personnel.



The word **CAUTION** preceded by the safety alert symbol indicates that a potentially hazardous situation exists which, if not avoided, may result in minor or moderate injury.



The word **CAUTION** without the safety alert symbol indicates a potentially hazardous situation exists which, if not avoided, may result in equipment and property damage.

CAUTION

Special Symbols

To identify special hazards, other symbols may appear in conjunction with the **DANGER**, **WARNING** and **CAUTION** signal words. These symbols indicate areas that require special and/or strict adherence to the procedures to prevent serious injury to personnel or death.

Electrical Hazard Symbol

A symbol which indicates a hazard of injury from electrical shock or burn. It is comprised of an equilateral triangle enclosing a lightning bolt.



Explosion Hazard Symbol

A symbol which indicates a hazard of injury from exploding parts. It is comprised of an equilateral triangle enclosing an explosion image.



Equipment Warning Labels

DO NOT attempt to install, operate, perform maintenance, or dispose of this equipment until you have read and understood all of the product labels and user directions that are contained in this manual.

Shown below are examples of safety labels that may be found attached to the equipment. **DO NOT** remove or cover any of the labels. If the labels are damaged or if additional labels are required, contact your Toshiba sales representative for additional labels.

Labels attached to the equipment are there to provide useful information or to indicate an imminently hazardous situation that may result in serious injury, severe property and equipment damage, or death if the instructions are not followed.

Figure 1. Examples of labels that may be found on the equipment.

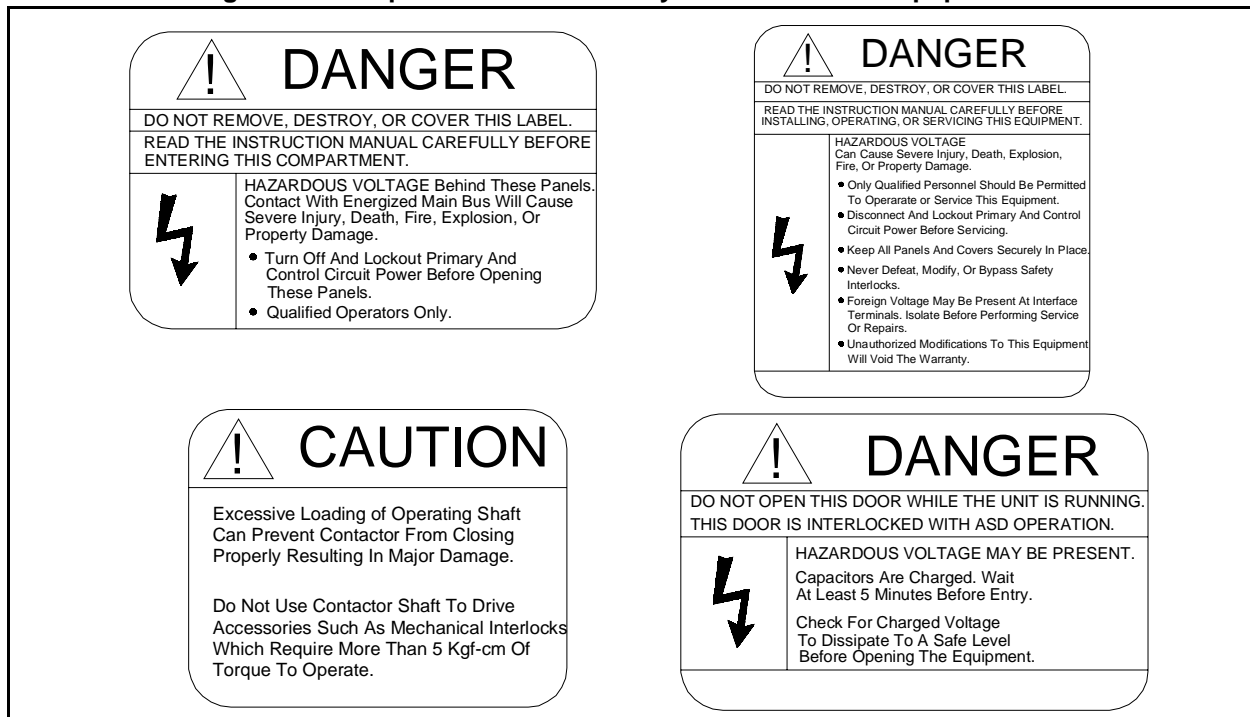

Qualified Personnel

Installation, operation, and maintenance shall be performed by **Qualified Personnel Only**. A **Qualified Person** is one that has the skills and knowledge relating to the construction, installation, operation, and maintenance of the electrical equipment and has received safety training on the hazards involved (Refer to the latest edition of NFPA 70E for additional safety requirements).

Qualified Personnel shall:

- Have carefully read the entire operation manual.
- Be familiar with the construction and function of the ASD, the equipment being driven, and the hazards involved.
- Able to recognize and properly address hazards associated with the application of motor-driven equipment.
- Be trained and authorized to safely energize, de-energize, ground, lockout/tagout circuits and equipment, and clear faults in accordance with established safety practices.
- Be trained in the proper care and use of protective equipment such as safety shoes, rubber gloves, hard hats, safety glasses, face shields, flash clothing, etc., in accordance with established safety practices.
- Be trained in rendering first aid.

For further information on workplace safety visit www.osha.gov.

Equipment Inspection

- Upon receipt of the equipment inspect the packaging and equipment for shipping damage.
- Carefully unpack the equipment and check for parts that were damaged during shipping, missing parts, or concealed damage. If any discrepancies are discovered, it should be noted with the carrier prior to accepting the shipment, if possible. File a claim with the carrier if necessary and immediately notify your Toshiba sales representative.
- **DO NOT** install or energize equipment that has been damaged. Damaged equipment may fail during operation resulting in equipment damage or personal injury.
- Check to see that the rated capacity and the model number specified on the nameplate conform to the order specifications.
- Modification of this equipment is dangerous and must not be performed except by factory trained representatives. When modifications are required contact your Toshiba sales representative.
- Inspections may be required before and after moving installed equipment.
- Keep the equipment in an upright position.
- Contact your Toshiba sales representative to report discrepancies or for assistance if required.

Handling and Storage

- Use proper lifting techniques when moving the ASD; including properly sizing up the load, getting assistance, and using a forklift if required.
- Store in a well-ventilated covered location and preferably in the original carton if the equipment will not be used upon receipt.
- Store in a cool, clean, and dry location. Avoid storage locations with extreme temperatures, rapid temperature changes, high humidity, moisture, dust, corrosive gases, or metal particles.
- The storage temperature range of the **H7 ASD** is 14° to 104° F (-10 to 40° C).
- Do not store the unit in places that are exposed to outside weather conditions (i.e., wind, rain, snow, etc.).
- Store in an upright position.

Disposal

Never dispose of electrical components via incineration. Contact your state environmental agency for details on disposal of electrical components and packaging in your area.

Installation Precautions

Location and Ambient Requirements

- The Toshiba ASD is intended for permanent installations only.
- Installation should conform to the **2005 National Electrical Code — Article 110 (NEC)** (*Requirements For Electrical Installations*), all regulations of the **Occupational Safety and Health Administration**, and any other applicable national, regional, or industry codes and standards.
- Select a mounting location that is easily accessible, has adequate personnel working space, and adequate illumination for adjustment, inspection, and maintenance of the equipment (refer to 2005 NEC Article 110-13).
- A noncombustible insulating floor or mat should be provided in the area immediately surrounding the electrical system.
- **Do Not** mount the ASD in a location that would produce catastrophic results if it were to fall from its mounting location (equipment damage or injury).
- **Do Not** mount the ASD in a location that would allow it to be exposed to flammable chemicals or gases, water, solvents, or other fluids.
- Avoid installation in areas where vibration, heat, humidity, dust, fibers, steel particles, explosive/corrosive mists or gases, or sources of electrical noise are present.
- The installation location shall not be exposed to direct sunlight.
- Allow proper clearance spaces for installation. Do not obstruct the ventilation openings. Refer to the section titled [Installation and Connections on pg. 18](#) for further information on ventilation requirements.
- The ambient operating temperature range of the **H7 ASD** is 14° to 104° F (-10 to 40° C).
- See the section titled [Installation and Connections on pg. 18](#) for additional information on installing the drive.

Mounting Requirements

- Only **Qualified Personnel** should install this equipment.
- Install the unit in a secure and upright position in a well-ventilated area.
- A noncombustible insulating floor or mat should be provided in the area immediately surrounding the electrical system at the place where maintenance operations are to be performed.
- As a minimum, the installation of the equipment should conform to the NEC Article 110 Requirements For Electrical Installations, OSHA, as well as any other applicable national, regional, or industry codes and standards.
- Installation practices should conform to the latest revision of NFPA 70E Electrical Safety Requirements for Employee Workplaces.
- It is the responsibility of the person installing the ASD or the electrical maintenance personnel to ensure that the unit is installed into an enclosure that will protect personnel against electric shock.

Conductor Routing and Grounding



- Use separate metal conduits for routing the input power, output power, and control circuits and each shall have its own ground cable.
- A separate ground cable should be run inside the conduit with the input power, output power, and control circuits.
- **DO NOT** connect control terminal strip return marked CC to earth ground.
- Always ground the unit to prevent electrical shock and to help reduce electrical noise.
- It is the responsibility of the person installing the ASD or the electrical maintenance personnel to provide proper grounding and branch circuit protection in accordance with the **2005 NEC** and any applicable local codes.

The Metal Of Conduit Is Not An Acceptable Ground.

Power Connections



Contact With Energized Wiring Will Cause Severe Injury Or Death.

- Turn off, lockout, and tagout all power sources before proceeding to connect the power wiring to the equipment.
- After ensuring that all power sources are turned off and isolated in accordance with established lockout/tagout procedures, connect three-phase power source wiring of the correct voltage to the correct input terminals and connect the output terminals to a motor of the correct voltage and type for the application (refer to NEC Article 300 – Wiring Methods and Article 310 – Conductors For General Wiring). Size the branch circuit conductors in accordance with NEC Table 310.16.
- If multiple conductors that are smaller than the recommended sizes are used in parallel for the input or output power, each branch of the parallel set shall have its own conduit and not share its conduit with other parallel sets (i.e., place U1, V1, and W1 in one conduit and U2, V2, and W2 in another) (refer to NEC Article 300.20 and Article 310.4). National and local electrical codes should be referenced if three or more power conductors are run in the same conduit (refer to 2005 NEC Article 310 adjustment factors on page 70-142).
- Ensure that the 3-phase input power is **Not** connected to the output of the ASD. This will damage the ASD and may cause injury to personnel.
- Do not install the ASD if it is damaged or if it is missing any component(s).
- **Do Not** connect resistors across terminals PA – PC or PO – PC. This may cause a fire.
- Ensure the correct phase sequence and the desired direction of motor rotation in the **Bypass** mode (if applicable).
- Turn the power on only after attaching and/or securing the front cover.

Protection

- Ensure that primary protection exists for the input wiring to the equipment. This protection must be able to interrupt the available fault current from the power line. The equipment may or may not be equipped with an input disconnect (option).
- All cable entry openings must be sealed to reduce the risk of entry by vermin and to allow for maximum cooling efficiency.
- Follow all warnings and precautions and do not exceed equipment ratings.
- If using multiple motors provide separate overload protection for each motor and use V/f control.
- External dynamic braking resistors must be thermally protected.
- It is the responsibility of the person installing the ASD or the electrical maintenance personnel to setup the **Emergency Off** braking system of the ASD. The function of the **Emergency Off** braking function is to remove output power from the drive in the event of an emergency. A supplemental braking system may also be engaged in the event of an emergency. For further information on braking systems, see [DC Injection Braking Start Frequency on pg. 111](#) and [Dynamic Braking Enable on pg. 119](#).

***Note:** A supplemental emergency stopping system should be used with the ASD. Emergency stopping should not be a task of the ASD alone.*

- Follow all warnings and precautions and do not exceed equipment ratings.

System Integration Precautions

The following precautions are provided as general guidelines for the setup of the ASD within the system.

- The Toshiba ASD is a general-purpose product. It is a system component only and the system design should take this into consideration. Please contact your Toshiba sales representative for application-specific information or for training support.
- The Toshiba ASD is part of a larger system and the safe operation of the ASD will depend on observing certain precautions and performing proper system integration.
- A detailed system analysis and job safety analysis should be performed by the systems designer and/or systems integrator before the installation of the ASD component. Contact your Toshiba sales representative for options availability and for application-specific system integration information if required.

Personnel Protection

- Installation, operation, and maintenance shall be performed by **Qualified Personnel Only**.
- A thorough understanding of the ASD will be required before the installation, operation, or maintenance of the ASD.



- Rotating machinery and live conductors can be hazardous and shall not come into contact with humans. Personnel should be protected from all rotating machinery and electrical hazards at all times.
- Insulators, machine guards, and electrical safeguards may fail or be defeated by the purposeful or inadvertent actions of workers. Insulators, machine guards, and electrical safeguards are to be inspected (and tested where possible) at installation and periodically after installation for potential hazardous conditions.
- Do not allow personnel near rotating machinery. Warning signs to this effect shall be posted at or near the machinery.
- Do not allow personnel near electrical conductors. Human contact with electrical conductors can be fatal. Warning signs to this effect shall be posted at or near the hazard.
- Personal protection equipment shall be provided and used to protect employees from any hazards inherent to system operation.
- Follow all warnings and precautions and do not exceed equipment ratings.

System Setup Requirements

- When using the ASD as an integral part of a larger system, it is the responsibility of the ASD installer or maintenance personnel to ensure that there is a fail-safe in place, i.e., an arrangement designed to switch the system to a safe condition if there is a fault or failure.
- System safety features should be employed and designed into the integrated system in a manner such that system operation, even in the event of system failure, will not cause harm or result in personnel injury or system damage (i.e., E-Off, Auto-Restart settings, System Interlocks, etc.).

- The programming setup and system configuration of the ASD may allow it to start the motor unexpectedly. A familiarity with the Auto-restart settings are a requirement to use this product.
- Improperly designed or improperly installed system interlocks may render the motor unable to start or stop on command.
- The failure of external or ancillary components may cause intermittent system operation, i.e., the system may start the motor without warning.
- There may be thermal or physical properties, or ancillary devices integrated into the overall system that may allow for the ASD to start the motor without warning. Signs at the equipment installation must be posted to this effect.
- If a secondary magnetic contactor (MC) is used between the ASD and the load, it should be interlocked to halt the ASD before the secondary contact opens. If the output contactor is used for bypass operation, it must be interlocked such that commercial power is never applied to the ASD output terminals (U, V, W).
- Power factor improvement capacitors or surge absorbers must not be installed on the output of the ASD.
- Use of the built-in system protective features is highly recommended (i.e., E-Off, Overload Protection, etc.).
- The operating controls and system status indicators should be clearly readable and positioned where the operator can see them without obstruction.
- Additional warnings and notifications shall be posted at the equipment installation location as deemed required by **Qualified Personnel**.
- Follow all warnings and precautions and do not exceed equipment ratings.

Operational and Maintenance Precautions



- Turn off, lockout, and tagout the main power, the control power, and instrumentation connections before inspecting or servicing the drive, or opening the door of the enclosure.
- Turn off, lockout, and tagout the main power, the control power, and instrumentation connections before proceeding to disconnect or connect the power wiring to the equipment.
- The capacitors of the ASD maintain a residual charge for a period of time after turning the ASD off. The required time for each ASD typeform is indicated with a cabinet label and a **Charge LED**. Wait for at least the minimum time indicated on the enclosure-mounted label and ensure that the **Charge LED** has gone out before opening the door of the ASD once the ASD power has been turned off.
- Turn the power on only after attaching (or closing) the front cover and **Do Not** remove the front cover of the ASD when the power is on.
- **Do Not** attempt to disassemble, modify, or repair the ASD. Call your Toshiba sales representative for repair information.
- Do not place any objects inside of the ASD.
- If the ASD should emit smoke or an unusual odor or sound, turn the power off immediately.
- The heat sink and other components may become extremely hot to the touch. Allow the unit to cool before coming in contact with these items.
- Remove power from the ASD during extended periods of non-use.
- The system should be inspected periodically for damaged or improperly functioning parts, cleanliness, and to ensure that the connectors are tightened securely.
- Ensure that the **Run** functions (**F**, **R**, **Preset Speed**, etc.) of the ASD are off before performing a **Reset**. The post-reset settings may allow the ASD to start unexpectedly.
- **Retry** or **Reset** settings may allow the motor to start unexpectedly. Warnings to this effect should be clearly posted near the ASD and motor.
- In the event of a power failure, the motor may restart after power is restored.
- Follow all warnings and precautions and do not exceed equipment ratings.

DO NOT install, operate, perform maintenance, or dispose of this equipment until you have read and understood all of the product warnings and user directions. Failure to do so may result in equipment damage, operator injury, or loss of life.

Service Life Information

Part Name	Service Life	Remarks
Large Capacity Electrolytic Capacitor	5 Years	When not used for long periods, charge semi-annually.
Cooling Fan	26,000 Hours	
CN Connectors	100 Connects/Disconnects	
On-board Relays	500,000 Actuations	

CE Compliance Requirements

In addition to the local and regional safety requirements, this section describes additional criteria that must be met to qualify for **European Conformity** (CE) certification. All relevant apparatus placed on the European market is required to comply to the European Community directive on electromagnetic compatibility (EMC). The following instructions provide a means of compliance for the 7-series of ASDs. A Technical Construction File (TFC) indicates the rationale used to declare compliance and is on file at Toshiba International Corporation, Houston, Texas U.S.A.

EMC Installation Guidelines

All systems placed on the European market are required to comply with the European Community directive regarding electromagnet compatibility (EMC). Toshiba ensures that all systems deployed in the European market have been screened and are in 100% compliance with the following standards:

- Radiated Interference: EN 55011 Group 1 Class A
- Mains Interference: EN 55011 Group 1 Class A
- Radiated Susceptibility: IEC 801-3 1984
- Conducted RFI Susceptibility: prEN55101-4 (prIEC801-6) Doc 90/30270
- Electrostatic Discharge: IEC801-2 1991
- Electrical Fast Transient: IEC 801-4 1988
- Surge: IEC1000-4-5 1995 2 KV line-to-line, 4 KV line-to-earth
- Voltage Interruption: IEC 1000-4-11

General EMC Guidelines for Consideration

- Input filters of the appropriate rating shall be used.
- Proper grounding is a requirement.
- Grounds shall be kept to the minimum length to accomplish the connection.
- Grounds shall have low RF impedance.
- A central ground shall employed in a complex system.
- Paint or corrosion can hamper good grounding; remove as required.
- Keep control and power cabling separated. Minimize exposed (unscreened) cable.
- Use 3600 screened connections where possible.

CE Compliant Installation Guidelines

ASDs should be installed in accordance with the following guidelines.

1. **Filtering** — An input filter shall be used with the ASD. A Schaffner FN258 series input filter of the appropriate rating shall be mounted next to the ASD.
2. **Mechanical** — The ASD and the associated equipment shall be mounted on a flat metallic backplane. A minimum space of 5 cm (2 inches) shall be between the ASD and the filter to allow for ventilation. The filter output cable is to be connected from the bottom of the filter to the ASD

power input and is to be the minimum length required for a connection. See [Table 1 on page 13](#) for filter selection assistance.

Units received as an Open Chassis shall not be placed into operation until being placed into an approved enclosure that will protect personnel against electrical shock.

Opening and closing of enclosures or barriers should be possible only with the use of a key or a tool.

3. **Cabling** — The power, filter, and motor cables shall be of the appropriate current rating. The cables shall be connected in accordance with the guidelines of the manufacturer and the applicable local and national agencies. A 4-core screened cable (such as RS 379-384) is to be used for the power and earth connections to minimize RF emissions. Control cabling must be screened using P/N RS 367-347 or a similar component.
4. **Grounding** — The mains (input) ground shall be connected at the ground terminal provided on the filter. The filter and motor shall be grounded at the ground terminals provided in the ASD.
5. **Screening** — The mains (input) screen is to be connected to the metallic back-plane at the filter; remove any finish coating as required. The screen over the filter output cables, the motor cable screen, and the control wire screens must be connected to the ASD case using glands or conduit connectors. The motor cable screen shall be connected to the motor case. When using a braking resistor, the cabling between the resistor and ASD shall also be screened. This screen shall connect to both the ASD enclosure and the resistor enclosure.
6. Where residual-current-operated protective device (RCD) is used for protection in case of direct or indirect contact, only RCD of type B is allowed on the supply side of this Electronic Equipment (EE). Otherwise, another protective measure shall be applied, such as separation of the EE from the environment by double or reinforced insulation, or isolation of the EE and the supply system by a transformer.

See the H7 Filter Selection on [pg. 13](#) for the recommended input filters for a given typeform.

Table 1. Filter selection table.

H7 Filter Selection Table			
230V		VT130H7U4110B	FN258-30
VT130H7U2010B	FN258-7	VT130H7U4160B	
VT130H7U2015B	FN258-16	VT130H7U4220B	FN258-42
VT130H7U2025B		VT130H7U4270B	FN258-55
VT130H7U2035B		VT130H7U4330B	
VT130H7U2055B	FN258-30	VT130H7U4400B	FN258-75
VT130H7U2080B		VT130H7U4500B	FN258-100
VT130H7U2110B	FN258-42	VT130H7U4600B	
VT130H7U2160B	FN258-75	VT130H7U4750B	FN258-130
VT130H7U2220B	FN258-100	VT130H7U410KB	FN258-180
VT130H7U2270B		VT130H7U412KB	FS5236-300
VT130H7U2330B		VT130H7U415KB	
460V		VT130H7U420KB	FS5236-500
VT130H7U4015B	FN258-7	VT130H7U425KB	
VT130H7U4025B		VT130H7U430KB	
VT130H7U4035B		600V	
VT130H7U4055B	FN258-16	VT130H7U6015B	FN258-7
VT130H7U4080B		VT130H7U6025B	
VT130H7U4110B	FN258-30	VT130H7U6035B	
VT130H7U4160B		VT130H7U6055B	FN258-16
VT130H7U4220B	FN258-42	VT130H7U6080B	
VT130H7U4270B	FN258-55	VT130H7U6110B	FN258-30
VT130H7U4330B		VT130H7U6160B	
VT130H7U4400B	FN258-75	VT130H7U6220B	FN258-42
VT130H7U4500B	FN258-100	VT130H7U6270B	
VT130H7U4600B		VT130H7U6330B	FN258-55
VT130H7U4750B	FN258-130	VT130H7U6400B	
VT130H7U410KB	FN258-180	VT130H7U6500B	FN258-75
VT130H7U412KB	FS5236-300	VT130H7U6600B	FN258-100
VT130H7U415KB		VT130H7U6750B	
VT130H7U420KB	FS5236-500	VT130H7U610KB	FN258-130
VT130H7U425KB		VT130H7U612KB	FS5236-180
VT130H7U430KB		VT130H7U615KB	
VT130H7U4015B	FN258-7	VT130H7U620KB	FS5236-300
VT130H7U4025B		VT130H7U625KB	FS5236-500
VT130H7U4035B		VT130H7U630KB	
VT130H7U4055B	FN258-16		
VT130H7U4080B			

Motor Characteristics

Listed below are some variable speed AC motor control concepts with which the user of the **H7 Adjustable Speed Drive** should become familiar.

Motor Autotuning

Motor production methods may cause minor differences in the motor operation. The negative effects of these differences may be minimized by using the **Autotune** feature of the **H7 ASD**. **Autotuning** is a function of the H7 ASD that measures several parameters of the connected motor and places these readings in a stored table. The software uses the information in the table to help optimize the response of the H7 ASD to application-specific load and operational requirements. The **Autotuning** function may be enabled for automatic tuning, configured manually at **F400**, or disabled.

The measured parameters include the rotor resistance, the stator resistance, the required excitation inductance, rotational inertia values, and leakage inductance values.

The H7 ASD is also equipped with a factory-loaded table of motor parameters that fit several different types of motors. To use this function, disable **Autotune** and select a motor type at **F413**.

Pulse Width Modulation Operation

The **H7 ASD** uses a sinusoidal **Pulse Width Modulation** (PWM) control system. The output current waveform generated by the H7 ASD approaches that of a perfect sine wave; however, the output waveform is slightly distorted. For this reason, the motor may produce more heat, noise, and vibration when operated by an H7 ASD, rather than directly from commercial power.

Low Speed Operation

Operating a general-purpose motor at lower speeds may cause a decrease in the cooling ability of the motor. Reducing the torque requirement of the motor at lower speeds will decrease the generated heat at lower speeds.

When the motor is to be operated at low speed (less than 50% of full speed) and at the rated torque continuously, a Toshiba VF motor (designed for use in conjunction with an H7 ASD) is recommended. When the H7 ASD is used with a VF motor, the **VF Motor** overload protection setting must be enabled (see Program ⇒ Protection Parameters ⇒ Overload ⇒ **V/f Motor Enable/Disable**).

Overload Protection Adjustment

The **H7 ASD** software monitors the output current of the system and determines when an overload condition occurs. The overload current level is a percentage of the rated system current. This function protects the motor from overload.

The default setting for the overload detection circuit is set to the maximum rated current of the H7 ASD at the factory. This setting will have to be adjusted to match the rating of the motor with which the H7 ASD is to be used. To change the overload reference level, see [Electronic Thermal Protection #1 on pg. 161](#).

Operation Above 60 Hz

A motor produces more noise and vibration when it is operated at frequencies above 60 Hz. Also, when operating a motor above 60 Hz, the rated limit of the motor or its bearings may be exceeded; this may void the motor warranty.

Contact the motor manufacturer for additional information before operating the motor above 60 Hz.

Power Factor Correction

DO NOT connect a power factor correction capacitor or surge absorber to the output of the H7 ASD.

If the H7 ASD is used with a motor that is equipped with a capacitor for power factor correction, remove the capacitor from the motor.

Connecting either of these devices to the output of the H7 ASD may cause the H7 ASD to malfunction and trip, or the output device may cause an over-current condition resulting in damage to the device or the H7 ASD.

Light Load Conditions

When a motor is operated under a continuous light load (i.e., at a load of less than 50% of its rated capacity) or it drives a load which produces a very small amount of inertia, it may become unstable and produce abnormal vibration or trips because of an over-current condition. In such a case, the carrier frequency may be lowered to compensate for this undesirable condition (see Program ⇒ Special Control Parameters ⇒ **Carrier Frequency**).

Note: For proper operation, the carrier frequency must be 2.2 kHz or above except when operating in the **Constant Torque**, **Variable Torque**, or the **5-Point Setting** modes.

Note: See **F300** for more information on setting the carrier frequency for normal operation and for setting the carrier frequency above the derate threshold.

Motor/Load Combinations

When the H7 ASD is used in combination with one of the following motors or loads, it may result in unstable operation.

- A motor with a rated capacity that exceeds the motor capacity recommended for the H7 ASD.
- An explosion-proof motor.

When using the H7 ASD with an explosion-proof motor or other special motor types, lower the carrier frequency to stabilize the operation. **DO NOT** set the carrier frequency below 2.2 kHz if operating the system in the vector control mode.

Note: For proper operation, the carrier frequency must be 2.2 kHz or above except when operating in the **Constant Torque**, **Variable Torque**, or the **5-Point Setting** modes.

- If the motor that is coupled to a load that has a large backlash or a reciprocating load, use one of the following procedures to stabilize its operation.
 - Adjust the **S-pattern** acceleration/deceleration setting,
 - If in the **Vector** control mode, adjust the response time, or
 - Switch to the **Constant Torque** control mode.

Load-produced Negative Torque

When the H7 ASD is used with a load that produces negative torque (an overhauling load), the over-voltage or over-current protective functions of the H7 ASD may cause nuisance tripping.

To minimize the undesirable effects of negative torque the dynamic braking system may be used if so equipped. The dynamic braking system converts the regenerated energy into heat that is dissipated using a braking resistor. The braking resistor must be suitably matched to the load. Dynamic braking is also effective in reducing the DC bus voltage during a momentary over-voltage condition.

If under extreme conditions the dynamic braking system or a component of this system were to fail, the dynamic braking resistor may experience an extended over-current condition. The DBR circuit was designed to dissipate excessive amounts of heat and if the extended over-current condition were allowed to exceed the circuit parameters, this condition could result in a fire hazard.

To combat this condition, the 3-phase input may be connected using contactors that are configured to open in the event of an extended DBR over-current condition or an internal circuit failure. Using a thermal sensor and/or overload protection as the 3-phase input contactor drive signal, the contactors will open and remove the 3-phase input power in the event of an extended DBR over-current or system over-voltage condition.

Motor Braking

The motor may continue to rotate and coast to a stop after being shut off due to the inertia of the load. If an immediate stop is required, a braking system should be used. The two most common types of motor braking systems used with the **H7 ASD** are **DC Injection Braking** and **Dynamic Braking**.

For further information on braking systems, see [DC Injection Braking on pg. 111](#) and [Dynamic Braking Enable on pg. 119](#).

H7 ASD Characteristics

Overcurrent Protection

Each **H7 ASD** model was designed for a specified operating power range. The H7 ASD will incur a trip if the design specifications are exceeded.

However, the H7 ASD may be operated at 120% of the specified output-current range for a limited amount of time as indicated in the section titled [Current/Voltage Specifications on pg. 205](#). Also, the [Overcurrent Stall Level](#) may be adjusted to help with nuisance over-current trips (see [F601](#)).

When using the H7 ASD for an application that controls a motor which is rated significantly less than the maximum current rating of the H7 ASD, the over-current limit (Thermal Overload Protection) setting will have to be changed to match the application. For further information on this parameter, see [Electronic Thermal Protection #1](#).

H7 ASD Capacity

The **H7 ASD** must not be used with a motor that has a significantly larger capacity, even if the motor is operated under a small load. An H7 ASD being used in this way will be susceptible to a high-output peak current which may result in nuisance tripping.

Do not apply a level of input voltage to an H7 ASD that is beyond that which the H7 ASD is rated. The input voltage may be stepped down when required with the use of a step-down transformer or some other type of voltage reduction system.

Using Vector Control

Using **Vector Control** enables the system to produce very high torque over the entire operating range even at extremely low speeds. **Vector Control** may be used with or without feedback. However, using feedback increases the speed accuracy for applications requiring precise speed control. Enabling the **Automatic Energy Savings** further increases the efficiency of the H7 ASD while maintaining its robust performance.

Vector Control is not capable of operating multiple motors connected in parallel.

See [F015 on pg. 65](#) for further information on using **Vector Control**.

Local/Remote Operation

While running in the **Local** mode at a non-zero speed, if the RJ45 connector is removed from the **EOI** and then reinserted, the H7 ASD remains in the **Local** mode even though the **Local LED** is off (press **Run** to illuminate the **Local LED**). The H7 ASD output remains at the frequency of the **Frequency Command** field at the time of the disconnect so long as the connector is disconnected.

Once reinserted, the reference frequency that was loaded into the EEPROM (not RAM) before the disconnect will be the frequency to which the H7 ASD output will return.

To prevent this condition, before disconnecting the RJ45 connector ensure that the H7 ASD is off.

Installation and Connections

The **H7 True Torque Control² Adjustable Speed Drive** may be set up initially by performing a few simple configuration settings. To operate properly, the ASD must be securely mounted and connected to a power source (3-phase AC input at the **L1/R**, **L2/S**, and **L3/T** terminals). The control terminals of the ASD may be used by connecting the terminals of the **Control Terminal Strip** to the proper sensors or signal input sources (see the section titled **I/O and Control** on pg. 23).

Note: *The optional **ASD-Multicom** boards may be used to expand the I/O functionality of the ASD. See the section titled **H7 ASD Optional Devices** on pg. 212 for further information on the available options.*

The output terminals of the ASD (**T1/U**, **T2/V**, and **T3/W**) must be connected to the motor that is to be controlled (see **Figure 18** on pg. 31).

As a minimum, the installation of the ASD shall conform to **Article 110** of the **2005 NEC**, the **Occupational Safety and Health Administration** requirements, and to any other local and regional industry codes and standards.

Upon initial system powerup, the **Startup Wizard** starts automatically. The **Startup Wizard** assists the user with the initial configuration of the **H7 True Torque Control² Adjustable Speed Drive**. See the section titled **Initial Setup** on pg. 34 for additional information on the **Startup Wizard**.

Installation Notes

When a brake-equipped motor is connected to the ASD, it is possible that the brake may not release at startup because of insufficient voltage. To avoid this, **Do Not** connect the brake or the brake contactor to the output of the ASD.

If an output contactor is used for bypass operation, it must be interlocked such that commercial power is never applied to the output terminals of the ASD (**T1/U**, **T2/V**, or **T3/W**).

If a secondary magnetic contactor (MC) is used between the output of the ASD and the motor, it should be interlocked such that the **ST – CC** connection is disconnected before the output contactor is opened.

Do Not open and then close a secondary magnetic contactor between the ASD and the motor unless the ASD is off and the motor is not rotating.

Note: *Re-application of power via a secondary contact while the ASD is on or while the motor is still turning may cause ASD damage.*

On some devices the **ST-to-CC** connection is further enhanced by the operation of the **MS1 AUX** relay circuit. The **MS1 AUX** relay circuit is normally open and closes the **ST-to-CC** connection (via **ST1**) only after normal system power is available. The **MS1 AUX** relay circuit prohibits the **ST-to-CC** connection in the event that the **MS1** contactor fails to close during start up or if **MS1** opens while the ASD is running. For the 230 volt ASD this feature is available on the 30 HP system, on the 460 volt ASD this feature is available on the 75 HP and above systems, and on the 600 volt ASD it is available on the 60 HP and above systems.

Figure 2. ST activation using the MS1 AUX circuit configuration.

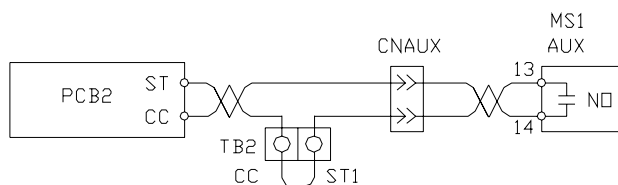

The ASD input voltage should remain within 10% of the specified input voltage range. Input voltages approaching the upper or lower limit settings may require that the overvoltage and undervoltage stall protection level parameters, **F626** and **F629**, be adjusted. Voltages outside of the permissible tolerance should be avoided.

The frequency of the input power should be ± 2 Hz of the specified input frequency.

Do not use an ASD with a motor that has a power rating that is higher than the rated output of the ASD.

The ASD is designed to operate NEMA B motors. Consult with your sales representative before using the ASD for special applications such as with an explosion-proof motor or applications with a piston load.

Do Not apply commercial power to the output terminals **T1/U**, **T2/V**, or **T3/W**.

Disconnect the ASD from the motor before megging or applying a bypass voltage to the motor.

Interface problems may occur when an ASD is used in conjunction with some types of process controllers. Signal isolation may be required to prevent controller and/or ASD malfunction (contact your Toshiba sales representative or the process controller manufacturer for additional information about compatibility and signal isolation).

Use caution when setting the output frequency. Over speeding a motor decreases its ability to deliver torque and may result in damage to the motor and/or the driven equipment.

All **H7 ASDs** are equipped with internal DC bus fuses. However, not all **H7 ASDs** are equipped with internal primary power input fuses (HP dependent). When connecting two or more drives that have no internal fuse to the same power line as shown in [Figure 3](#), it will be necessary to select a circuit-breaking configuration that will ensure that if a short circuit occurs in ASD 1, only MCCB2 trips, not MCCB1. If it is not feasible to use this configuration, insert a fuse between MCCB2 and ASD 1.

Figure 3. Circuit breaker configuration.

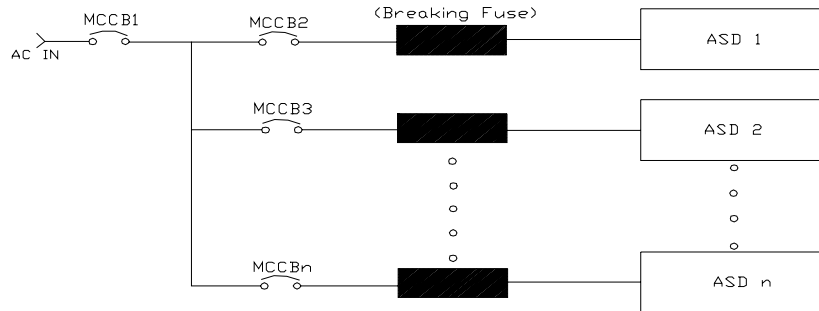

Mounting the ASD

CAUTION

Install the unit securely in a well ventilated area that is out of direct sunlight using the mounting holes on the rear of the ASD. When replacing an H3 ASD with an **H7 ASD**, see [H7 ASD Adapter Mounting Plates](#) on pg. 198 for a listing of the optional **H3-to-H7 Adapter Mounting Plates**

The ambient temperature rating for the **H7 ASD** is from 14 to 104° F (-10 to 40° C). The process of converting AC to DC, and then back to AC produces heat. During normal ASD operation, up to 5% of the input energy to the ASD may be dissipated as heat. If installing the ASD in a cabinet, ensure that there is adequate ventilation.

Do Not operate the ASD with the enclosure door open.

When installing multiple ASDs, ensure that there is a clearance space of at least 8 inches (20 cm) from the top and the bottom of adjacent units. There should be at least 2 inches (5 cm) on either side of adjacent units. For the models below 50 HP the top and bottom clearance specifications may be reduced to 4 inches (10 cm). This space ensures that adequate ventilation is provided (see the section titled [Enclosure Dimensions and Conduit Plate Information on pg. 190](#) for additional information on mounting space requirements).

Note: *Ensure that the ventilation openings are not obstructed.*

ASDs produce high-frequency noise — steps must be taken during installation to avoid the negative effects of noise. Listed below are some examples of measures that will help to combat noise problems.

- Separate the input and output power conductors of the main circuit. Do not install the input and output wires in the same duct or in parallel with each other, and do not bind them together.
- Do not install the input or output power conductors of the main circuit and the wires of the control circuit in the same duct or in parallel with each other, and do not bind them together.
- Use shielded wires or twisted wires for the control circuits.
- Ensure that the grounding terminals (G/E) of the ASD are securely connected to ground.
- Connect a surge suppressor to every electromagnetic contactor and every relay installed near the ASD.
- Install noise filters as required.

Connecting the ASD



Refer to the section titled [Installation Precautions on pg. 5](#) and the section titled [Lead Length Specifications on pg. 22](#) before attempting to connect the ASD and the motor to electrical power.

System Grounding

Proper grounding helps to prevent electrical shock and to reduce electrical noise. The ASD is designed to be grounded in accordance with **Article 250** of the **2005 NEC** or **Section 10/Part One** of the **Canadian Electrical Code (CEC)**.

The grounding conductor shall be sized in accordance with **Article 250-122** of the **NEC** or **Part One-Table 6** of the **CEC**.

Note: *The metal of conduit is not an acceptable ground.*

The input, output, and control lines of the system shall be run in separate metal conduits and each shall have its own ground conductor.

Power Connections



L1/R, **L2/S**, and **L3/T** are the 3-phase input supply terminals for the ASD. The ASD may be operated from a single-phase supply. When operating using a single-phase supply, use the **L1** and **L3** terminals.

T1/U, **T2/V**, and **T3/W** are the output terminals of the ASD that connect to the motor.

An inductor may be connected across terminals **PA** and **PO** to provide additional filtering. When not used, a jumper is connected across these terminals (see [Figure 18 on pg. 31](#)).

Connect the input and output power lines of the ASD as shown in [Figure 4](#).

Note: *In the event that the motor rotates in the wrong direction when powered up, reverse any two of the three ASD output power leads connected to the motor.*

Figure 4. ASD/Motor connection diagram.

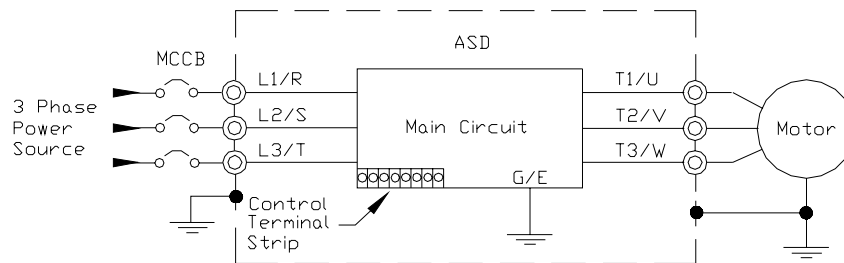

Connect the 3-phase input power to the input terminals of the ASD at **L1/R**, **L2/S**, and **L3/T**. Connect the output of the ASD to the motor from terminals **T1/U**, **T2/V**, and **T3/W**. The input and output conductors and terminal lugs used shall be in accordance with the requirements listed in the section titled [Cable/Terminal Specifications on pg. 208](#).

If multiple conductors are used in parallel for the input or output power and it is necessary to use separate conduits, each parallel set shall have its own conduit and not share its conduit with other parallel sets (i.e., place U1, V1, and W1 in one conduit and U2, V2, and W2 in another) (refer to NEC Article 300.20 and Article 310.4). National and local electrical codes should be referenced if three or more power conductors are run in the same conduit (refer to 2005 NEC Article 310 adjustment factors).

Note: *National and local codes should be referenced when running more than three conductors in the same conduit.*

Install a molded case circuit breaker (MCCB) or fuse between the 3-phase power source and the ASD in accordance with the fault current setting of the ASD and **2005 NEC Article 430**.

CAUTION

For 600 volt ASDs, the 15 HP or less ASDs (P/N VT130H7U6015B – 6160B) require a class-J fuse rated at 600 Volts/30 A.

A phase-shifting transformer (or other means) must be supplied by the user when configured for 12-pulse operation.

External fuses are required on the ASDs listed below when configured for 12-pulse operation.

VT130H7U2750B(DR)
 VT130H7U210KB(DR)
 VT130H7U415KB(DR)
 VT130H7U420KB(DR)
 VT130H7U612KB(DR)
 VT130H7U615KB(DR)
 VT130H7U620KB(DR)

Use either the Ferraz Shawmut Semiconductor fuse (P/N A70QS200) and fuse block P234C, or the Toshiba ASD-FUSEKIT-12P. The Toshiba kit includes the required fuses and the mounting hardware for the fuses.

Lead Length Specifications

Adhere to the NEC and any local codes during the installation of ASD/Motor systems. Excessive lead lengths may adversely effect the performance of the motor. Special cables are not required. Lead lengths from the ASD to the motor in excess of those listed in [Table 2](#) may require filters to be added to the output of the ASD. [Table 2](#) lists the suggested maximum lead lengths for the listed motor voltages.

Table 2.

Model	PWM Carrier Frequency	NEMA MG-1-1998 Section IV Part 31 Compliant Motors ²
230 Volt	All	1000 feet
460 Volt	< 5 kHz	600 feet
	≥ 5 kHz	300 feet
600 Volt	< 5 kHz	200 feet
	≥ 5 kHz	100 feet

Note: Contact Toshiba for application assistance when using lead lengths in excess of those listed.

Exceeding the peak voltage rating or the allowable thermal rise time of the motor insulation will reduce the life expectancy of the motor.

*For proper operation, the carrier frequency must be 2.2 kHz or above except when operating in the **Constant Torque**, **Variable Torque**, or the **5-Point Setting** modes.*

Startup and Test

Perform the following checks before turning on the unit:

- **L1/R**, **L2/S**, and **L3/T** are connected to the 3-phase input power.
- **T1/U**, **T2/V**, and **T3/W** are connected to the motor.
- The 3-phase input voltage is within the specified tolerance.
- There are no shorts and all grounds are secured.

I/O and Control

The ASD can be controlled by several input types and combinations thereof, as well as operate within a wide range of output frequency and voltage levels. This section discusses the ASD control methods and supported I/O functions.

The **Control Terminal Strip** PCB (P/N 48570) supports discrete and analog I/O functions and is shown in [Figure 6 on pg. 26](#). [Table 3](#) lists the names, the default settings, and the descriptions of the input and output terminals of the **Control Terminal Strip** PCB.

Note: To use the input control lines of the **Control Terminal Strip** the **Command Mode** setting must be set to **Use Control Terminal Strip** (Program ⇒ Fundamental Parameters ⇒ Standard Mode Selection ⇒ Command Mode ⇒ **Use Control Terminal Strip**).

[Figure 18 on pg. 31](#) shows the basic connection diagram for the **H7 ASD** system.

Table 3. Control Terminal Strip default assignment terminal names and functions.

Default Term. Setting	Input/Output	Default Function (also see Terminal Descriptions on pg. 24)	Circuit Config.
ST	Discrete Input	Standby (jumper to CC to operate the unit) — Multifunctional programmable discrete input (see Installation Notes on pg. 18 for further information on this terminal).	Figure 8 on pg. 30.
RES	Discrete Input	Reset — Multifunctional programmable discrete input.	
F	Discrete Input	Forward — Multifunctional programmable discrete input.	
R	Discrete Input	Reverse — Multifunctional programmable discrete input.	
S1	Discrete Input	Preset Speed 1 — Multifunctional programmable discrete input.	
S2	Discrete Input	Preset Speed 2 — Multifunctional programmable discrete input.	
S3	Discrete Input	Preset Speed 3 — Multifunctional programmable discrete input.	
S4	Discrete Input	Emergency Off — Multifunctional programmable discrete input.	
RR	Analog Input	RR — Multifunctional programmable analog input (0.0 to 10 volt input — 0 to 80 Hz output). Reference CC.	Figure 9 on pg. 30.
RX	Analog Input	RX — Multifunctional programmable analog input (-10 to +10 VDC input — -80 to +80 Hz output). Reference CC.	Figure 10 on pg. 30.
II	Analog Input	II — Multifunctional programmable analog input (4 [0] to 20 mADC input — 0 to 80 Hz output) (see Figure 6 on pg. 26 for the location of the II terminal). Reference CC.	Figure 11 on pg. 30.
VI	Analog Input	VI — Multifunctional programmable analog input (0 to 10 VDC input — 0 to 80 Hz output). Reference CC.	
P24	DC Output	24 VDC @ 50 mA output.	Figure 12 on pg. 30.
PP	DC Output	PP — 10.0 VDC voltage source for the external potentiometer.	Figure 13 on pg. 30.
OUT1	Discrete Output	Low Frequency — Multifunctional programmable discrete output.	Figure 14 on pg. 30.
OUT2	Discrete Output	Reach Frequency — Multifunctional programmable discrete output.	
FP	Output	Frequency Pulse — an output pulse train that has a frequency which is based on the output frequency of the ASD.	Figure 15 on pg. 30.
AM	Output	Produces an output current that is proportional to the magnitude of the function assigned to this terminal (see Table 7 on page 62).	Figure 16 on pg. 30
FM	Output		
FLC	Output	Fault relay (common).	Figure 17 on pg. 30.
FLB	Output	Fault relay (N.C.).	
FLA	Output	Fault relay (N.O.).	
CC	—	Control common (Do Not connect to Earth Gnd).	
Discrete Input Terminals ⇒ Connect to CC to activate. Analog Input Terminals reference CC .			

Terminal Descriptions

Note: *The programmable terminal assignments may be accessed and changed from their default settings as mapped on pg. 48 or via the **Direct Access** method: Program ⇒ Direct Access ⇒ **applicable parameter number**. See the section titled [Program Mode on pg. 48](#) for the applicable **Direct Access** parameter numbers.*

*For further information on terminal assignments and default setting changes, see the section titled [Output Terminal Functions on pg. 50](#) and **CHANGED FROM DEFAULT on pg. 48**.*

ST — The default setting for this terminal is **ST**. The function of this input as **ST** is a **Standby** mode controller (system is in **Standby** when on). As the default setting, this terminal must be connected to **CC** for normal operation. If not connected to **CC**, **Off** is displayed on the LCD screen. This input terminal may be programmed to any 1 of the 68 possible functions that are listed in [Table 8 on page 77](#) (see [F113](#)).

RES — The default setting for this terminal is **RES**. The function of this input as **RES** is a system **Reset**. A momentary connection to **CC** resets the ASD and any fault indications from the display. This input terminal may be programmed to any 1 of the 68 possible functions that are listed in [Table 8 on page 77](#) (see [F114](#)). **Reset** is effective when faulted only. If not faulted this terminal is ignored.

F — The default setting for this terminal is **F**. The function of this input as **F** is **Forward Run**. A connection to **CC** runs the motor in the **Forward** direction when it is on. This input terminal may be programmed to any 1 of the 68 possible functions that are listed in [Table 8 on page 77](#) (see [F111](#)).

R — The default setting for this terminal is **R**. The function of this input as **R** is **Reverse Run**. A connection to **CC** runs the motor in the **Reverse** direction when it is on. This input terminal may be programmed to any 1 of the 68 possible functions that are listed in [Table 8 on page 77](#) (see [F112](#)).

S1 — The default setting for this terminal is **S1**. The function of this input as **S1** is to run the motor at **Preset Speed #1** (see [Preset Speed #1 on pg. 67](#)) when it is on. This input terminal may be programmed to any 1 of the 68 possible functions that are listed in [Table 8 on page 77](#) (see [F115](#)).

S2 — The default setting for this terminal is **S2**. The function of this input as **S2** is to run the motor at **Preset Speed #2** (see [Preset Speed #2 on pg. 67](#)) when it is on. This input terminal may be programmed to any 1 of the 68 possible functions that are listed in [Table 8 on page 77](#) (see [F116](#)).

S3 — The default setting for this terminal is **S3**. The function of this input as **S3** is to run the motor at **Preset Speed #3** (see [Preset Speed #3 on pg. 68](#)) when it is on. This input terminal may be programmed to any 1 of the 68 possible functions that are listed in [Table 8 on page 77](#) (see [F117](#)).

S4 — The default setting for this terminal is **Emergency Off** (normally closed). The function of this input as **Emergency Off** is to remove power from the output of the ASD and may apply a supplemental braking system using the method selected at [F603](#). This input terminal may be programmed to any 1 of the 68 possible functions that are listed in [Table 8 on page 77](#) (see [F118](#)).

RR — The default function assigned to this terminal is to carry out the **Frequency Mode #1** setting. The **RR** terminal accepts a 0 – 10 VDC input signal that controls the function assigned to this terminal. This input terminal may be programmed to control the speed or torque of the motor. It may also be used to regulate (limit) the speed or torque of the motor. The gain and bias of this terminal may be adjusted for application-specific suitability (see [F210 – F213](#)).

RX — The **RX** terminal accepts a ±10 VDC input signal that controls the function assigned to this terminal. This input terminal may be programmed to control the speed, torque, or direction of the motor. It may also be used to regulate (limit) the speed or torque of the motor. The gain and bias of this terminal may be adjusted for application-specific suitability (see [F216 – F219](#)).

II — The function of the **II** input is to receive a 4 – 20 mA input signal that controls a 0 – 80 Hz output. This input terminal may be programmed to control the speed or torque of the motor and may not be used when using the **VI** input. Also, the gain and bias of this terminal may be adjusted (see **F201 – F204**).

VI — The function of the **VI** input terminal is to receive a 0 – 10 VDC input signal that controls a 0 – 80 Hz output. This input terminal may be programmed to control the speed or torque of the motor and may not be used when using the **II** input. Also, the gain and bias of this terminal may be adjusted (see **F201 – F204**).

P24 — +24 VDC @ 50 mA power supply for customer use.

PP — The function of output **PP** is to provide a 10 VDC output that may be divided using a potentiometer. The tapped voltage is applied to the **RR** input to provide manual control of the **RR** programmed function.

OUT1 — The default setting for this output terminal is the **Output Low Speed** indicator. This output terminal may be programmed to provide an indication that 1 of 62 possible events has taken place. This function may be used to signal external equipment or to activate the brake (see **F130**). The **OUT1** contact is rated at 2A/250 VAC.

OUT2 — The default setting for this output terminal is the **ACC/DEC Complete** indicator. This output terminal may be programmed to provide an indication that 1 of 62 possible events has taken place. This function may be used to signal external equipment or to activate the brake (see **F131**). The **OUT2** contact is rated at 2A/250 VAC.

FP — The default function of this output terminal is to output a series of pulses at a rate that is a function of the output frequency of the ASD. As the output frequency of the ASD goes up so does the **FP** output pulse rate. This terminal may be programmed to provide output pulses at a rate that is a function of the output frequency or the magnitude of any 1 of the 33 the functions listed in [Table 7 on pg. 62](#) (see **F676**).

AM — This output terminal produces an output current that is proportional to the output frequency of the ASD or of the magnitude of the function assigned to this terminal. The available assignments for this output terminal are listed in [Table 7 on pg. 62](#). For further information on this terminal see parameter **F670**.

FM — This output terminal produces an output current that is proportional to the output frequency of the ASD or of the magnitude of the function assigned to this terminal. The available assignments for this output terminal are listed in [Table 7 on pg. 62](#). For further information on this terminal see **F005**.

FLC — **FLC** is the middle leg of a single-pole double-throw (relay) switch. This **FLC** contact of the relay is switched between **FLB** and **FLA**. This contact may be programmed to switch between **FLB** and **FLA** as a function of any 1 of the 62 conditions listed in [Table 9 on pg. 82](#) (see **F132** and [Figure 5](#)).

FLB — One of two contacts that, under user-defined conditions, connect to **FLC** (see [Figure 5](#)).

FLA — One of two contacts that, under user-defined conditions, connect to **FLC** (see [Figure 5](#)).

Note: *The **FLA** and **FLC** contacts are rated at 2A/250 VAC. The **FLB** contact is rated at 1A/250 VAC.*

CC — Control common (**Do Not** connect to **Earth Gnd**).

Figure 5. FLA, FLB, and FLC switching contacts shown in the de-energized state.

Note: *The relay is shown in the **Faulted** or de-energized condition. During normal system operation the relay connection is **FLC-to-FLA**.*

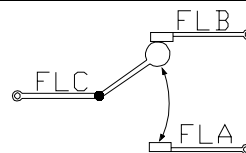
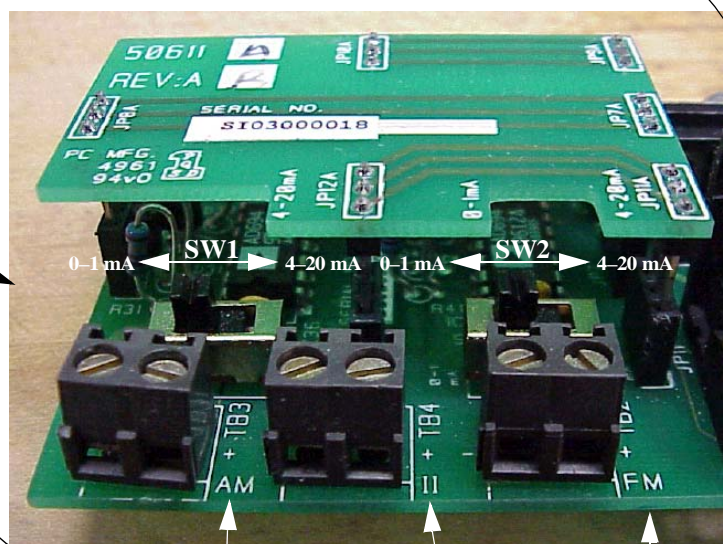
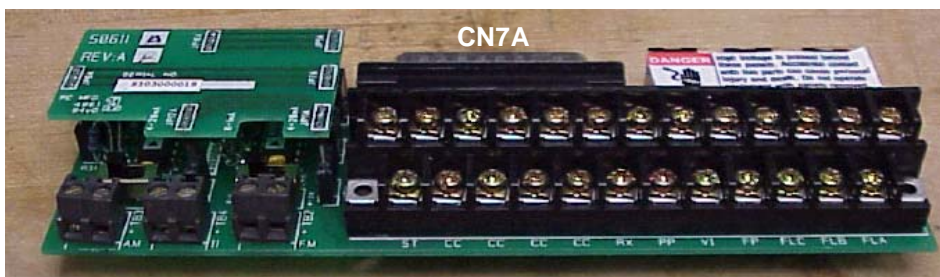

Figure 6. Control Terminal Strip PCB.



SW1 and SW2 may be switched to change the full-scale reading of the AM and FM output terminals. See F670 and F005 for further information on the AM and FM terminal adjustments.

II Terminals

Shown below are the input and output terminals of the Control Terminal Strip. For further information on these terminals see pg. 23.

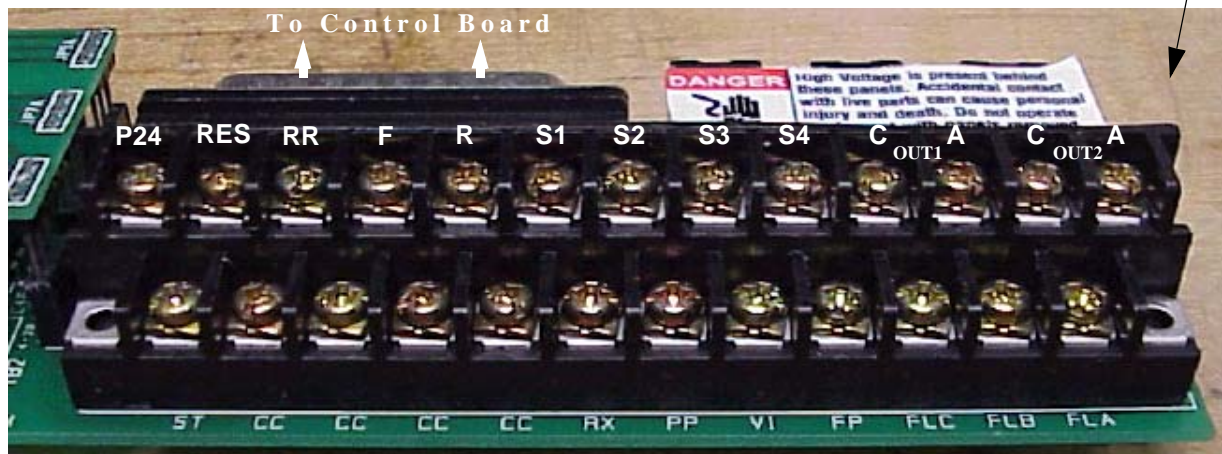

H7 ASD Control

The Control PCB (P/N 56000) serves as the primary control source for the **H7 ASD** and receives input from the Control Terminal Strip PCB (see [Figure 6 on pg. 26](#)), an Option Card, RS232/RS485 Communications, or the EOI.

The Control PCB has been enhanced to support two new functions: Multiple Protocol Communications and the ability to communicate in either half- or full-duplex modes.

Using the optional multiple-protocol communications interface; the ASD-NANOCOM, the Control PCB may be configured for the type of communications protocol being received and respond appropriately to the sending device. The ASD-NANOCOM connects to the J4 and J5 connectors (see [Figure 7](#)). A jumper PCB (P/N 55365) is required at the J4 connector if not using the ASD-NANOCOM.

The ASD-NANOCOM must be setup to support the desired communications protocol via Program ⇒ Communication Setting Parameters ⇒ **Communication Settings**. Consult the ASD-NANOCOM User's Manual (P/N 10572-1.000-000) for a complete listing of the setup requirements.

Half or Full duplex communications is available when using RS232/RS485 communications. The jumpers at the JP1 and the JP2 connectors may be moved from one position to the other to facilitate either half- or full-duplex operation. If no jumpers are used the system will operate in the full duplex mode.

For more information on the **H7 ASD** communication requirements, please visit WWW.TIC.TOSHIBA.COM to acquire a copy of the 7-Series Communications User Manual and visit WWW.ICCDESIGNS.COM to acquire a copy of the ASD-NANOCOM User Manual.

Contact your Toshiba representative if more information is required on the ASD-NANOCOM.

Figure 7. Control Board of the **H7 ASD** (P/N 56000).

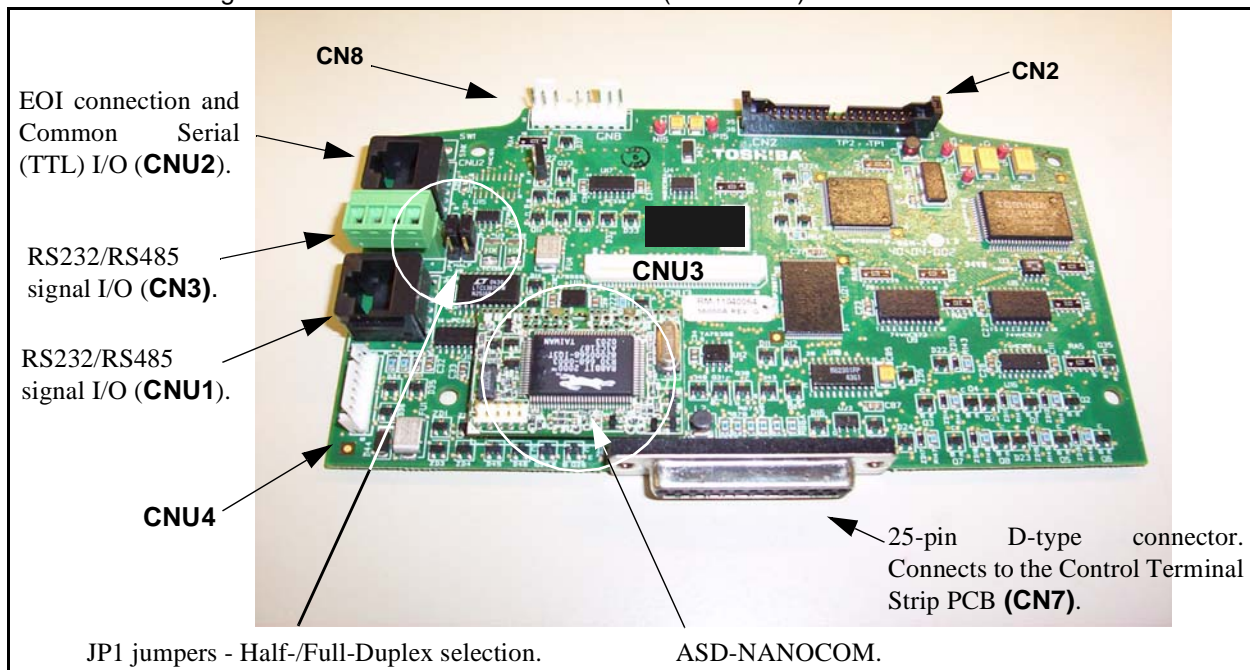

CNU1/1A and CNU2/2A Pinout

Pin #	CNU1 Pinout (Controller PCB)	CNU1A Pinout (EOI)	Pin #	CNU2 Pinout (Controller PCB)	CNU2A Pinout (EOI)
1	P24	P24	1	P24	P24
2	Gnd	Gnd	2	Gnd	Gnd
3	Tx (-)	RXA	3	Rx	Tx
4	Rx (+)	TXA	4	Gnd	Gnd
5	Rx (-)	TXB	5	Tx	Rx
6	Tx (+)	RXB	6	Gnd	Gnd
7	$\overline{\text{RS232/RS485}}$	CNU3 Pin-7	7	Open	Open
8	Gnd	Gnd	8	Gnd	Gnd

Note: For normal operation, connect CNU1 to CNU1A or CNU2 to CNU2A. **DO NOT** connect both. If both are connected, the TTL and RS232/RS485 signals will be transferred simultaneously to and from the EOI and the control board resulting in a **Communications Lost** error message or erratic ASD operation.

Note: Connecting CNU1 to CNU2A will result in a continuous splash screen display. Connect CNU1 to CNU1A and continue normally.

Connecting CNU2 to CNU1A will result in a continuous splash screen display. Connect CNU2 to CNU2A and continue normally.

Note: See the 7-Series Communications Manual (P/N 53840) for further information on the **H7 ASD** communications protocol and system configuration requirements.

CN3 Pinout

CN3 is used for RS232/RS485 serial communications.

Pin Number	CNU3 Pinout (Controller PCB)
1	RS232/RS485 Signal +
2	RS232/RS485 Signal -
3	RS232/RS485 Signal Gnd
4	Shield

CN7 Pinout

Listed below are the pinouts of the **CN7** connector. The **CN7** connector is the 25-pin D-type connector of the **Control Board** (see [Figure 7](#)).

Table 4. CN7 pinout assignments. Listed are the default settings for the programmable terminals.

Pin Number	CN7 Pinout	Pin Number	CN7 Pinout
1	PP	14	II
2	FL	15	S1
3	VI	16	R
4	RR	17	S3
5	FM	18	S2
6	RX	19	N15
7	FP	20	S4
8	AM	21	P15
9	*OUT1	22	P24
10	*OUT2	23	CC
11	ST	24	CC
12	RES	25	CC
13	F	—	—
<i>Note: * Open collector outputs.</i>			

I/O Circuit Configurations

<p>Figure 8. Discrete input.</p> <p>Configured Sink (may be configured Source)</p>	<p>Figure 9 RR input.</p>
<p>Figure 10. RX input.</p>	<p>Figure 11. VI/II input.</p> <p>VI and II inputs may not be used simultaneously.</p>
<p>Figure 12. P24 Output.</p> <p>Fuse resets after high current is removed.</p>	<p>Figure 13. PP Output.</p>
<p>Figure 14. OUT1/OUT2 Output.</p>	<p>Figure 15. FP Output.</p>
<p>Figure 16. AM/FM Output.</p>	<p>Figure 17. Fault Relay (during fault).</p>

Typical Connection Diagram

Figure 18. H7 ASD typical connection diagram.

Note: When connecting multiple wires to the PA, PB, PC, or PO terminals, do not connect a solid wire and a stranded wire to the same terminal.

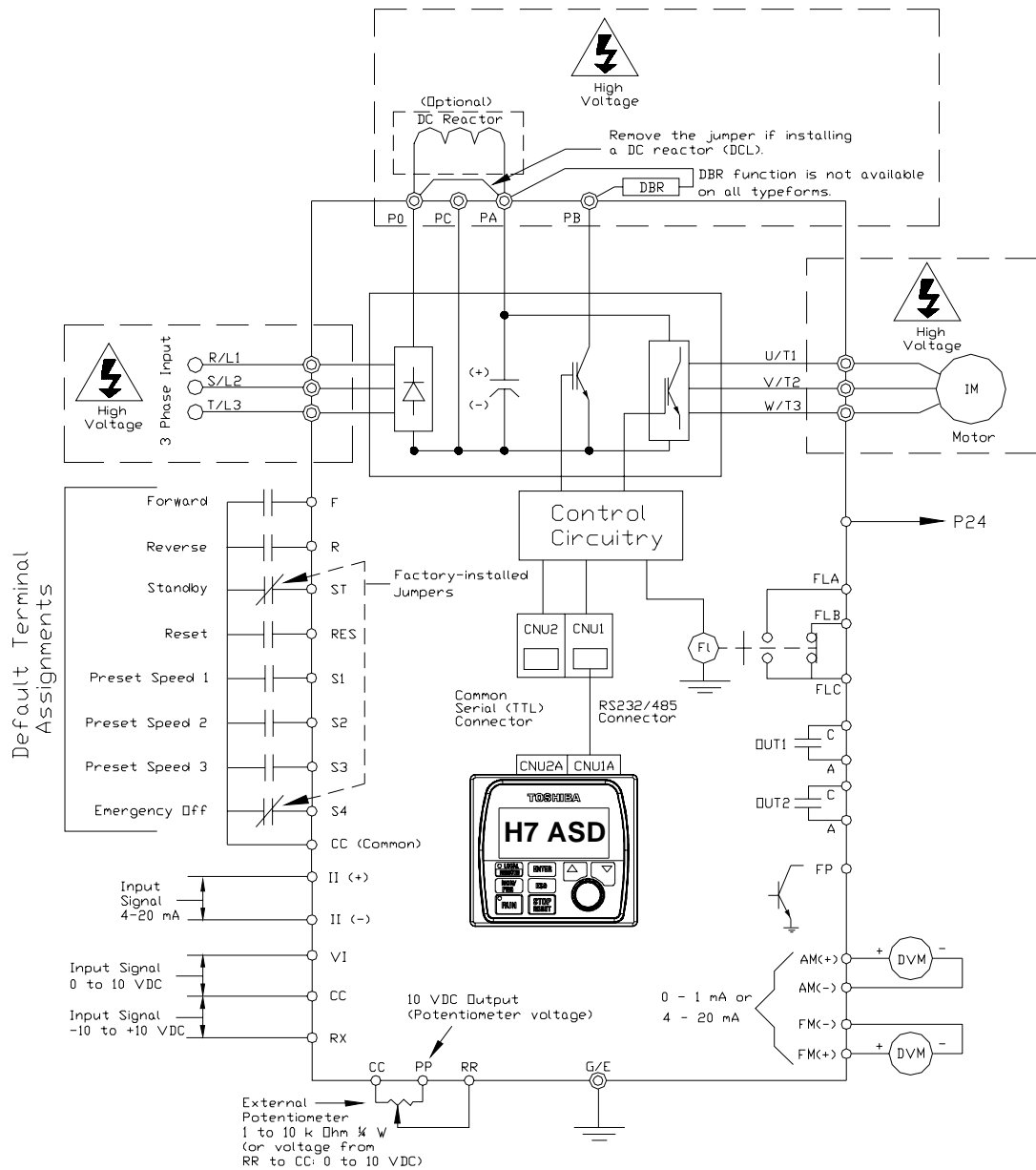

Note: The AM, FM, VI, and II analog terminals are referenced to CC.

Note: See alternative ST-to-CC activation configuration on [pg. 18](#).

Electronic Operator Interface

The H7 ASD **Electronic Operator Interface** (EOI) is comprised of an LCD display, two LEDs, a rotary encoder, and eight keys. These items are described below and their locations are shown in [Figure 19 on pg. 33](#).

The **EOI** can be mounted remotely from the ASD as described in the section titled [EOI Remote Mounting on pg. 202](#). The mounting dimensions may also be found on [pg. 202](#). Using a screw length that exceeds the specified dimensions may cause deformation of the outer surface of the bezel as shown in [Figure 35 on pg. 204](#) and should be avoided.

The EOI can operate up to distances of 15 feet from the ASD via the Common Serial (TTL) Port. For distances beyond 15 feet, the RS-485 port is recommended.

EOI Features

LCD Display — Displays configuration information, performance data (e.g., motor frequency, bus voltage, torque, etc.), and diagnostic information.

Local|Remote Key — Toggles the system to and from the **Local** and **Remote** modes. The LED is on when the system is in the **Local Command** mode. The **Local** mode allows the **Command** and **Frequency** control functions to be carried out via the **EOI**.

The **Remote** mode enables the **Command** and **Frequency** control functions to be carried out via the **Control Terminal Strip, LED Keypad, RS232/485, Communication Card, or Pulse Input**. The selection may be made via Program ⇒ Fundamental Parameters ⇒ Standard Mode Settings ⇒ [Command Mode](#).

*Note: The **LED Keypad** is under development and is unavailable at the time of the release of this manual.*

The availability of the **Local** mode of operation (**Command** and **Frequency** control) may be disabled via Program ⇒ EOI Option Setups ⇒ [Local/Remote Key](#). The availability of the **Local** mode of operation may be reinstated by changing this setting or performing a **Reset** (see [F007](#)).

Enter Key — Selects a menu item to be changed or accepts and records the changed data of the selected field (same as pressing the **Rotary Encoder**).

Esc Key — Returns to the previous level of the menu tree, toggles between the **Panel** and the **Frequency Command** screens, or cancels changes made to a field if pressed while still in the reverse video mode (dark background/light text).

Run Key — Issues the **Run** command while in the **Local** mode.

Run Key Status LED — Illuminates green while stopped or red while running.

Stop Key — Issues the **Off** command (decelerates to **Stop** at the programmed rate) if pressed once while in the **Local** mode or initiates an **Emergency Off** (terminates the ASD output and applies the brake if so configured) if pressed twice quickly from the **Local** or **Remote** modes.

Up Key — Increases the value of the selected parameter or scrolls up the menu listing (continues during press and hold).

Down Key — Decreases the value of the selected parameter or scrolls down the menu listing (continues during press and hold).

Rotary Encoder — Functions as the **Up** key, the **Down** key, and the **Enter** key. Turn the **Rotary Encoder** either clockwise or counterclockwise to perform the **Up** or **Down** key functions. Press the **Rotary Encoder** to perform the **Enter** function. Simultaneously pressing and turning the **Rotary Encoder** performs a user-defined function (see Program ⇒ EOI Option Setup ⇒ Preferences ⇒ [Encoder Action](#)).

MON/PRG — Provides a means to access the three root menus. Pressing the **MON/PRG** key repeatedly loops the system through the three root menus (see [Figure 22 on pg. 44](#)). While looping through the root menus, the **Program** menu will display the last menu screen or sub-menu item being accessed at the time that the **MON/PRG** key was pressed.

Figure 19. The H7 ASD Electronic Operator Interface.

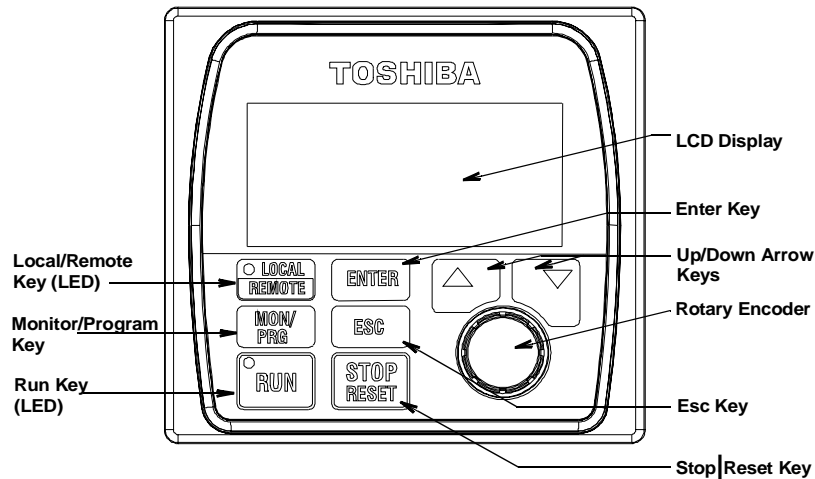

EOI Operation

The **EOI** is the primary input/output device for the user. The **EOI** may be used to monitor system functions, input data into the system, or perform diagnostics.

Note: *The Up/Down arrow keys and the Enter key may be used to perform the functions of the Rotary Encoder. The Rotary Encoder will be used in this explanation and throughout this manual for the Up, Down, and Enter key functions.*

The software used with the H7 ASD is menu driven; thus, making it a select and click environment. The operating parameters of a motor may be selected and viewed or changed using the **EOI**.

To change a parameter setting, go to the **Program** mode by pressing the **MON/PRG** key until the **Program** menu is displayed. Turn the **Rotary Encoder** until the desired parameter (group) is within the cursor block. Press the **Rotary Encoder** to select (repeat if there is a submenu).

The selection will take on the reverse video format (dark background/light text). Turn the **Rotary Encoder** to change the value of the parameter. Press the **Esc** key while the display is in the reverse video mode to exit the menu without saving the change or press the **Rotary Encoder** to accept the new setting.

Repeated **Esc** key entries takes the menu back one level each time the **Esc** key is pressed until the root level is reached. After reaching the root level, continued **Esc** entries will toggle the system to and from the **Frequency Command** screen and the **Panel** menu.

Note: *System changes made while in the Panel menu will affect Local LCD EOI-controlled ASD operation only. LED Keypad-controlled functions will not be affected. LED Keypad-controlled operation settings may be viewed or changed at [F008](#).*

System Operation

Initial Setup

Upon initial system powerup, the **Startup Wizard** starts automatically. The **Startup Wizard** assists the user with the initial configuration of the input power settings and the output parameters of the **H7 ASD**. The **H7 ASD** may also be setup by directly accessing each of the individual parameters (see the section titled [Direct Access Parameter Information on pg. 60](#)).

The **Startup Wizard** queries the user for the following information:

1. **Run now?** (if selected continue on to step #2)/**Run next time at power up?** (if selected go to Program Mode)/**Manually configure?** (if selected go to Finish ⇒ Program Mode).
2. The **Voltage** and **Frequency** rating of the motor.
3. The **Upper Limit** frequency.
4. The **Lower Limit** frequency.
5. Adjust **Accel/Decel** times automatically? (if **Yes**, continue from step #8).
6. The **Acceleration** time.
7. The **Deceleration** Time.
8. The **Volts/Hertz** setting.
9. The motor **Current** rating.
10. The **Command** source.
11. The **Frequency Reference** source.

See the section titled [Startup Wizard Requirements on pg. 36](#) for additional information on the **Startup Wizard**.

Operation (Local)

Note: See [F003](#) for information on **Remote** operation.

To turn the motor on, perform the following:

1. Press the **MON/PRG** key until the **Frequency Command** screen is displayed (see [Figure 20](#)).
2. Press the **Local|Remote** key to enter the **Local** mode (green **Local** LED illuminates).
3. Turn the **Rotary Encoder** clockwise until the **Frequency Command** value is at the desired setting.
4. Press the **Run** key and the motor runs at the **Frequency Command** value.

Note: The speed of the motor may be changed while the motor is running by using the **Rotary Encoder** to change the **Frequency Command** value.

5. Press the **Stop|Reset** key to stop the motor.

Figure 20. Frequency Command screen.

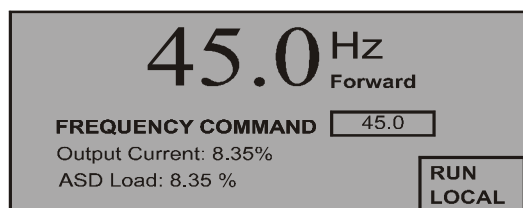

Default Setting Changes

To change a default parameter setting, go to the root of the **Program** menu and turn the **Rotary Encoder** until the desired parameter group is within the cursor block and press the **Rotary Encoder** (repeat if there is a submenu).

Press the **Rotary Encoder** to select the default setting to be changed and the selection takes on the reverse video format (dark background, light text). Turn the **Rotary Encoder** to change the value of the parameter. Press the **ESC** key before accepting the change to exit the menu without saving the change or press the **Rotary Encoder** to accept the new setting.

For a complete listing of the **Program** mode menu options, see the section titled [Program Mode on pg. 48](#). Menu items are listed and mapped for convenience. The **Direct Access Numbers** are listed where applicable.

The default settings may also be changed by entering the **Parameter Number** of the setting to be changed at the **Direct Access** menu (Program ⇒ Direct Access ⇒ *Applicable Parameter Number*). A listing of the **Direct Access/Parameter Numbers** and a description of the associated parameter may be found in the section titled [Direct Access Parameter Information on pg. 60](#).

A listing of all parameters that have been changed from the default setting may be viewed sequentially by accessing the **Changed From Default** screen (Program ⇒ **Changed From Default**).

Note: Parameter F201 was changed to create the example shown in [Figure 21](#).

The **Changed From Default** feature allows the user to view (or change) the parameters that are different from the default or the post-reset settings. Once the **Changed From Default** screen is displayed, the system automatically scrolls through all of the system parameters and halts once reaching a changed parameter.

The **Rotary Encoder** may be clicked once clockwise to continue scrolling forward or clicked once counterclockwise to begin scrolling in reverse. With each click of the **Rotary Encoder** from a stop, the system scrolls through the parameters and stops at the next parameter that has been changed.

Pressing the **Rotary Encoder** while a changed parameter is displayed accesses the settings of the changed parameter for viewing or changing.

Pressing **ESC** while the system is performing a **Changed From Default** search terminates the search. Pressing **ESC** when done searching (or halted at a changed parameter) returns the system to the **Program Menu**.

Figure 21. Changed From Default screen.

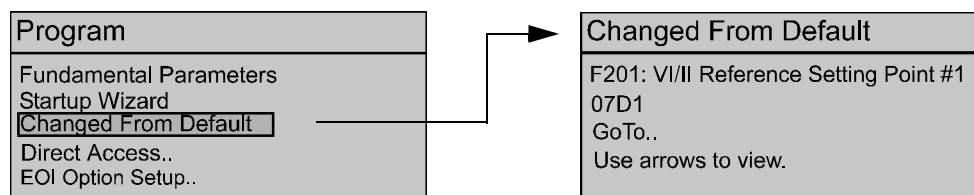

Startup Wizard Requirements

The **Startup Wizard** queries the user for information on the input and output signal parameters of the **H7 ASD**. The **H7 ASD** may also be setup by directly accessing each of the control settings via the **Program** menu or the **Direct Access Numbers** (see the section titled [Direct Access Parameter Information on pg. 60](#)).

Upon initial system powerup, the **Startup Wizard** starts automatically. The user is queried to either (1) run the **Startup Wizard (Run Now)**, (2) perform a manual setting of user-selected parameters, or (3) run the **Startup Wizard** at the next power up.

If selection (2) is chosen, the system returns to the **Program** menu and defaults to the **Startup Wizard** on the next power up. If selection (3) is chosen, click the **Finish** box and the system returns to the **Frequency Command** screen. If selection (1) (**Run Now**) is selected, the **Startup Wizard** will start and assist the user with the configuration of the **H7 True Torque Control² Adjustable Speed Drive** using the following user-input screens.

Voltage and Frequency Rating of the Motor

Motors are designed and manufactured for a specific voltage and frequency range. The voltage and frequency specifications for a given motor may be found on the nameplate of the motor.

Wizard: Motor Rating
<input type="text" value="200V 50Hz"/>
<input type="text" value="200V/230V 60Hz"/>
<input type="text" value="I will configure manually. Finish."/>

Upper Limit Frequency

This parameter sets the highest frequency that the **H7 ASD** will accept as a frequency command or frequency setpoint. The **H7 ASD** may output frequencies higher than the **Upper Limit Frequency** (but, lower than the **Maximum Frequency**) when operating in the **PID Control** mode, **Torque Control** mode, or the **Vector Control** modes (sensorless or feedback).

Wizard: Upper Limit Frequency
What is your upper limit frequency?
<input type="text" value="60"/> Hz
<input type="button" value="Next"/>
<input type="button" value="Finish."/>

Lower Limit Frequency

This parameter sets the lowest frequency that the **H7 ASD** will accept as a frequency command or frequency setpoint. The **H7 ASD** will output frequencies lower than the **Lower Limit Frequency** when accelerating to the lower limit or decelerating to a stop. Frequencies below the **Lower Limit** may be output when operating in the **PID Control** mode, **Torque Control** mode, or the **Vector Control** modes (sensorless or feedback).

Wizard: Min. Frequency
What is your lower limit frequency?
<input type="text" value="0.00"/> Hz
<input type="button" value="Next"/>
<input type="button" value="Finish."/>

Adjust Accel/Decel Automatically?

When enabled, the **H7 ASD** adjusts the acceleration and deceleration rates according to the applied load. The acceleration and deceleration times range from 12.5 to 800% of the programmed values for the active acceleration time [e.g., **Acceleration Time #1 (F009)** and **Deceleration Time #1 (F010)**].

The motor and the load must be connected prior to selecting **Automatic Accel/Decel**.

If **Automatic Accel/Decel** is not enabled, the **Acceleration** screen will appear followed by the **Deceleration** screen as shown below.

Wizard: Accel/Decel
Do you want the drive to adjust accel/decel times automatically?
<input type="button" value="Yes"/>
<input type="button" value="No"/>
<input type="button" value="Finish"/>

Acceleration Time

Wizard: Acceleration Time
What is your acceleration time?
<input type="text" value="10.0 sec"/>
<input type="button" value="Next"/>
<input type="button" value="Finish"/>

Deceleration Time

Wizard: Deceleration Time
What is your deceleration time?
<input type="text" value="10.0 sec"/>
<input type="button" value="Next"/>
<input type="button" value="Finish"/>

Volts per Hertz Setting

This function establishes the relationship between the output frequency and the output voltage of the ASD.

Settings:

- Constant Torque
- Variable Torque
- Automatic Torque Boost
- Sensorless Vector Control (Speed)
- Automatic Torque Boost + Automatic Energy Savings
- Sensorless Vector Control (Speed) + Automatic Energy Savings
- V/f 5-point Setting (Opens 5-point Setting Screen)
- Sensorless Vector Control (Speed/Torque Switching)
- PG Feedback Vector Control (Speed/Torque Switching)
- PG Feedback Vector Control (Speed/Position Switching)

Wizard: Volts/Hertz
What type of volts/hertz control do you want?
<input type="text" value="Constant Torque"/>
<input type="button" value="Next"/>
<input type="button" value="Finish"/>

Motor Current Rating

This parameter allows the user to input the full-load amperage (FLA) of the motor. This value is used by the **H7 ASD** to determine the **Thermal Overload** protection setting for the motor and may be found on the nameplate of the motor.

Wizard: Motor Current
What is the rated current of your motor?
<input type="text" value="5.00 A"/>
<input type="button" value="Next"/>
<input type="button" value="Finish"/>

Command Source

This selection allows the user to establish the source of the **Run** commands (e.g., **F**, **R**, **Stop**, etc.).

Settings:

- Use Control Terminal Strip
- Use LED Keypad Option
- Use Common Serial (TTL)
- Use RS232/485
- Use Communication Card

Wizard: Command Source
Where will your run/stop and other commands come from?
<input type="text" value="Use terminal block"/>
<input type="text" value="Next"/>
<input type="text" value="Finish"/>

Frequency Reference Source

This selection allows the user to establish the source of the **Frequency** (speed) command.

Settings:

- Use VI/II
- Use RR
- Use RX
- Use Option Card RX2
- Use LED Keypad Option
- Use Binary/BCD Input
- Use Common Serial (TTL)
- Use RS232/485
- Use Communication Card
- Use Motorized Pot Simulation
- Use Pulse Input Option

Wizard: Frequency Source
Where will your frequency reference come from?
<input type="text" value="Use RR"/>
<input type="text" value="Next"/>

Wizard: Finish

This screen is the final screen of the **Startup Wizard**. The basic parameters of the **H7 ASD** have been set. Click **Finish** to return to the **Program** mode. Additional application-specific programming may be required.

Wizard: Finished
Wizard is done. Other parameters may need adjustment for proper operation. Always read instruction manual to ensure proper setup.
<input type="text" value="Finish"/>

Command Mode and Frequency Mode Control

Command control includes instructions such as **Stop, Run, Jog**, etc. The source of the **Command** signal must be established for normal operation.

Frequency commands control the output speed of the ASD. The source of the frequency (speed) control signal must be established for normal operation.

The source of the command control and speed control may be either internal or external. Once the source signal is selected for either function, the system may be configured to use the selected signal all of the time or switch under user-defined conditions.

Command and **Frequency** control may be carried out using any one of several control methods (signal sources) or combinations thereof. In the event that multiple control commands are received, the signal sources are assigned priority levels. The primary control method for **Command** and **Frequency** control uses the settings of **F003** and **F004**, respectively.

Command Control (F003)

The **Command Mode** selection of **F003** establishes the primary source of the command input for the ASD. However, the **Override** feature may supersede the **F003** setting as indicated in [Table 5](#).

[Table 5](#) shows the hierarchy of the control sources managed by the **Override** function. The level of the control item on the hierarchy is listed from left to right, most to least, respectively. As indicated in the table, the **Override** setting may supersede the **F003** setting.

Placing the EOI in the **Local** mode selects either the **RS232/RS485** or the **Common Serial (TTL)** as the **Command Mode** control source. Once in the **Local** mode, the **LCD Port Connection** setting determines if the **RS232/RS485** or the **Common Serial (TTL)** will be used for **Command** control. **Local** mode operation may be superseded by other **Communications Override** settings.

Example: With the EOI set to **Local** and the **LCD Port Connection** set to **Common Serial (TTL)**, setting the **Communication Card** or **RS232/RS485** control to **Override** will supersede the **Common Serial (TTL)** setting.

The remaining control sources may be placed into the override mode using communications.

The source of the **Command** control signal may be selected by:

- The **F003** setting,
- Placing an item from the list below in the **Override** mode via communications, or
- Placing the EOI in the **Local** mode (places only the RS232/RS485 or the Common Serial [TTL] in the Override mode).

Possible **Command** signal source selections include the following:

- Use Control Terminal Strip (default),
- Use LED Keypad Option,
- Use Common Serial (TTL),
- Use RS232/RS485,

Standard Mode Settings
Command Mode:
Use Control Terminal Strip
Frequency Mode #1:
Use RR
Frequency Mode #2:

- Use Communication Card, or
- **F003** setting (is used if no signal sources are in the Override mode).

Note: *The **Control Terminal Strip** is placed in the **Override** mode by assigning a discrete terminal to **Command Control Terminal Strip Priority** and connecting the terminal to **CC**. Once activated (Run command required), the **Control Terminal Strip** settings will be used for **Override Command** control (F, R, Preset Speeds, etc.).*

Frequency Control (F004)

The **Frequency Mode #1** (or the **Frequency Mode #2**) setting establishes the user-selected source of the frequency-control input for the ASD. The signal source selected here is used for speed control unless the **Reference Priority Selection** parameter is configured to automatically switch this setting (see **F200**) or if the **Override** feature is enabled (via communications or via the Local mode operation).

Standard Mode Settings	
Frequency Mode #1:	<input type="text" value="Use RR"/>
Frequency Mode #2:	<input type="text" value="Use VI/II"/>
Reference Priority Selection:	<input type="text"/>

Table 5 shows the hierarchy of the control sources managed by the **Override** function. The level of the control item on the hierarchy is listed from left to right, most to least, respectively. As indicated in the table, the **Override** setting may supersede the selection at **F004**.

Placing the EOI in the **Local** mode selects either the **RS232/RS485** or the **Common Serial (TTL)** as the **Frequency Mode #1** control source. Once in the **Local** mode, the **LCD Port Connection** setting determines if the **RS232/RS485** or the **Common Serial (TTL)** will be used for **Frequency Mode #1** control. **Local** mode operation may be superseded by other **Communications Override** settings.

Example: With the EOI set to **Local** and the **LCD Port Connection** set to **Common Serial (TTL)**, setting the **Communication Card** or **RS232/RS485** control to **Override** will supersede the **Common Serial (TTL)** setting.

The remaining control sources may be placed into the override mode using communications.

The source of the **Frequency** control signal may be selected by:

- The **F004** setting,
- Placing an item from the list below in the **Override** mode via communications, or
- Placing the EOI in the **Local** mode (places only the RS232/RS485 or Common Serial in the Override mode).

Possible **Frequency** control source selections include the following:

- Communication Card,
- RS232/RS485,
- Common Serial (TTL),
- LED Keypad,
- Control Terminal Strip (default setting), or
- **F004** setting (used if no other items are in the Override mode).

Note: *The **Control Terminal Strip** is placed in the **Override** mode by assigning a discrete terminal to **VI/II Terminal Priority** and connecting the terminal to **CC**. Once the discrete terminal is activated, **VI/II** is used as the **Control Terminal Strip Override** control item.*

Command and Frequency Control Selections

The user may select only one **Command** source and only one source for **Frequency** control. The default settings for **Command** and **Frequency** control are **Use Control Terminal Strip** and **Use RR**, respectively.

The **H7 ASD** has a command register for each item listed as a **Command** or **Frequency** source. The registers store the **Override** setting for each control source. The registers are continuously scanned to determine if any of the listed items are in the **Override** mode.

For each scan cycle, the command registers of the control sources are scanned for the **Override** setting in the order that they are listed in [Table 5](#). The first item of the **Command** section and the first item of the **Frequency** section detected as being in the **Override** mode will be used for **Command** and **Frequency** control, respectively. If no items are detected as being in the **Override** mode, the settings of **F003** and **F004** will be used for **Command** and **Frequency** control, respectively.

Any or all of the **Command** and **Frequency** control input sources may be placed in the **Override** mode.

Placing the **H7 ASD** in the **Local** mode (Local/Remote LED on) via the EOI places the **RS232/RS485** or the **Common Serial (TTL)** control selections in the **Override** mode for **Command** and **Frequency** input (see the section titled [Override Operation](#) below for the proper setting). The **Local/Remote** control **Override** feature for **Command** and **Frequency** (or either) may be enabled/disabled at Program ⇒ EOI Option Setups ⇒ **Local-Remote Key** (enabled with check in box).

Communications may be used to place the remaining **Command** and eligible **Frequency** control input sources in the **Override** mode. Once placed in the **Override** mode this setting is valid until it is cancelled, the power supply is turned off, or the unit is reset.

Override Operation

The command registers of the listed signal sources are scanned in the order that they are listed in [Table 5](#) to determine which input sources are in the **Override** mode. During each register scan cycle, the first item detected as having the **Override** function turned on is the selection that is used for **Command** or **Frequency** control input.

The **Override** control setting supersedes the setting of the **Command** mode setting (**F003**) and the **Frequency** mode setting (**F004**). However, the **F003** and **F004** settings will be used in the event that the register scan returns the condition that none of the listed items have the **Override** feature turned on (see [Table 5](#)).

Command and Frequency-Control Override Hierarchy

[Table 5](#) lists the input conditions and the resulting output control source selections for Command and Frequency control Override operation. The H7 ASD reads the command registers of the listed control items from the left to the right. In the table the number 1 indicates that the Override feature is turned on for that control input source; X = Don't are; and 0 = Override Off.

The first item to be read that has the Override feature turned on will be used for Command or Frequency control.

Table 5. Command and Frequency control hierarchy.

1	2	3	4	5	6	Priority Level
Communication Card	RS232/RS485	Common Serial	Panel (LED Keypad)	Control Terminal (Binary/BCD Input)	F003/F004	Command/ Frequency Mode
1	X	X	X	X	X	Communication Card
0	1	X	X	X	X	RS232/RS485
0	0	1	X	X	X	Common Serial
0	0	0	1	X	X	Panel (LED Keypad)
0	0	0	0	1	X	Control Terminal
0	0	0	0	0	F003/F004 Setting	F003/F004 Setting

Command Control Selections

The following is a listing and description of the **Command Mode (F003)** selections (Program ⇒ Fundamental Parameters ⇒ Standard Mode Selection ⇒ **Command Mode**).

Settings:

Use Control Terminal Strip

Allows for **Command** control input via the 25-pin terminal strip on the **Control Terminal Strip** PCB.

Use LED Keypad Option

The **LED Keypad** is unavailable at the time of this release.

Use Common (TTL)

Set the **LCD Port Connection** to **Common Serial (TTL)** to use this feature.

Use RS232/RS485

Set the **LCD Port Connection** to **RS232/RS485** to use this feature.

Use Communication Card

Routes the control and monitoring I/O to CNU3 of the **Control Board** of the **H7 ASD** (Communication Card connector).

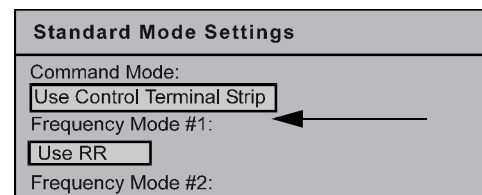

Frequency Control Selections

The following is a listing and description of the **Frequency Mode (F003)** selections (Program ⇒ Fundamental Parameters ⇒ Standard Mode Selection ⇒ **Frequency Mode #1**).

Settings:

Use VI/II

0 to 10-volt DC analog input connected to **VI** or a 4 – 20 mA (or 0 to 1 mA) DC current connected to **II** (cannot use both simultaneously).

Use RR

0 to 10-volt DC analog input connected to **RR**.

Use RX

-10 to +10-volt DC analog input connected to **RX**.

Use Option Card RX2

-10 to +10-volt DC analog input connected to **RX2**.

Use LED Keypad Option

The LED Keypad is unavailable at the time of this release.

Use Binary/BCD Input

Allows for discrete terminal input to control the ASD output.

Use Common Serial (TTL)

To use the EOI for control requires that the **LCD Port Connection** be set to **Common Serial (TTL)** to use this feature.

Use RS232/RS485

To use the EOI for control requires that the **LCD Port Connection** be set to **RS232/RS485** to use this feature.

Use Communication Card

Routes the control and monitoring I/O to CNU3 of the **Control Board** of the **H7 ASD** (Option Card connector).

Use Motorized Pot Simulation

A discrete terminal may be configured to increase or decrease the speed of the motor by momentarily connecting the assigned terminal to **CC**. See [Table 8 on page 77](#) for further information on this feature.

Use Pulse Input Option

Configures the system to receive pulse input. See **PG Speed Reference Setpoint** on [pg. 108](#) for further information on this feature.

Standard Mode Settings	
Command Mode:	Use Control Terminal Strip
Frequency Mode #1:	Use RR ←
Frequency Mode #2:	

System Configuration and Menu Options

Root Menus

The **MON/PRG** (Monitor/Program) key accesses the three primary modes of the **H7 ASD**: the **Frequency Command** mode, the **Monitor** mode, and the **Program** mode. From either mode, press the **MON/PRG** key to loop through to the other two modes (see [Figure 22](#)). While in the **Frequency Command** mode, pressing the **ESC** key toggles the menu to and from the **Panel** menu and the **Frequency Command** mode.

Note: Parameter changes made from the **Panel** menu are effective for **Local LCD EOI control Only**.

Figure 22. Root menu mapping.

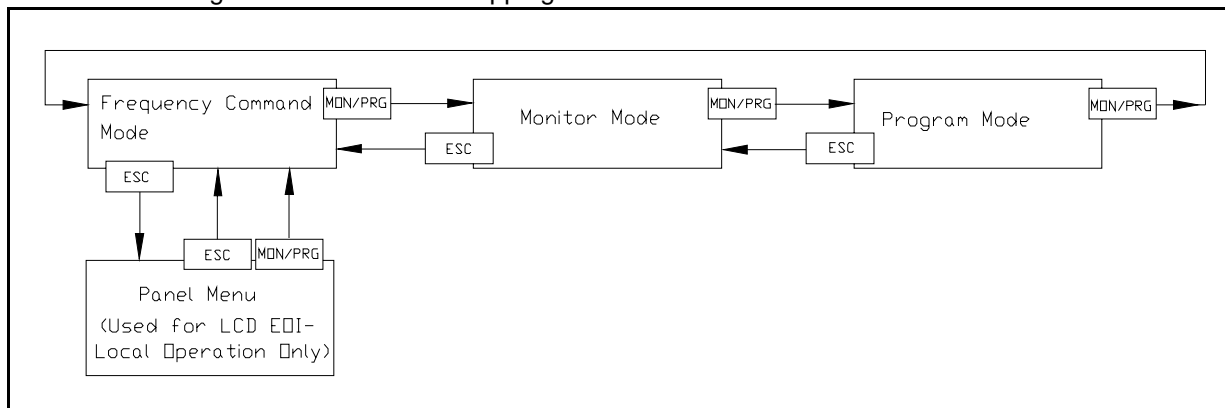

Frequency Command Mode

Frequency Setting

While operating in the **Local** mode (**Local** LED is illuminated on the front panel), the running frequency of the motor may be set from the **Frequency Command** screen. Using the **Rotary Encoder**, enter the **Frequency Command** value and then press the **Run** key. The motor will run at the **Frequency Command** speed and may be changed while running.

Scrolling Monitor

The **Output Current** and the **ASD Load** values are displayed below the **Frequency Command** parameter of the **Frequency Command** screen (default setting). Other user-selected parameters may be displayed on this screen for quick-access monitoring while running. These parameters may be accessed and enabled for display by placing a check in the box next to the item listed at Program ⇒ Monitor Setup ⇒ [Scrolling Monitor Select](#). If no parameters are enabled for display, **No Items** is displayed.

When more than two items are selected for display the items are scrolled automatically. The display time for each selected item may be set from 1 to 60 seconds. The parameters that may be displayed on the **Scrolling Monitor** are listed in the section titled [Monitor Mode on pg. 46](#).

Panel Menu

The Panel menu may be accessed in either of two ways: while operating using the **LED Keypad Option** the **Panel** menu may be accessed via **F008** or if operating in the **Local** mode using the **LCD EOI**, press **ESC** from the **Frequency Command** screen.

The control settings of the **Panel** menu are effective for **LED** keypad control only if accessed via **Direct Access** method **F008** and are effective for the **LCD EOI** control only if accessed via the **Frequency Command** screen. Changes made to either of the **Panel** menus are not carried over to the other **Panel** menu.

Using either method provides quick access to the following **Panel** menu parameters:

Direction — **Forward** or **Reverse** (see **F008** for further information on this setting).

Stop Pattern — The **Decel Stop** or **Coast Stop** settings determines the method used to stop the motor when using the **Stop|Reset** key of the **EOI**. The **Decel Stop** setting enables the **Dynamic Braking** system setup at **F304** or the **DC Injection Braking** system setup at **F250**, **F251**, and **F252**. The **Coast Stop** setting allows the motor to stop at the rate allowed by the inertia of the load.

Note: The **Stop Pattern** setting has no effect on the **Emergency Off** settings of **F603**.

V/f Group — 1 of 4 **V/f** profiles may be selected and run. Each **V/f** profile is comprised of 4 user settings: **Base Frequency**, **Base Frequency Voltage**, **Manual Torque Boost**, and **Electronic Thermal Protection**. Expanded descriptions of these parameters may be found in the section titled [Direct Access Parameter Information on pg. 60](#).

Accel/Decel Group — 1 of 4 **Accel/Decel** profiles may be selected and run. Each of the **Accel/Decel** profiles is comprised of 3 user settings: **Acceleration**, **Deceleration**, and **Pattern**. Expanded descriptions of these parameters may be found in the section titled [Direct Access Parameter Information on pg. 60](#) (or see **F009** at the **EOI**).

Feedback in Panel Mode — This feature enables or disables the **PID** feedback function.

Torque Limit Group — This parameter is used to select 1 of 4 preset positive torque limits to apply to the active motor (of a multiple motor configuration). The settings of profiles 1 – 4 may be setup at **F441**, **F444**, **F446**, and **F448**, respectively.

Monitor Mode

The **Monitor** mode allows the user to monitor motor performance variables, control settings, and configuration data during motor operation. There are 46 items that may be monitored from this mode. The items are listed and described below.

Note: The **Monitor** mode is a read-only mode. The settings **cannot** be changed from the **Monitor** mode. For information on how to change the values, see the section titled [Default Setting Changes on pg. 35](#).

Running Frequency — Displays the **H7 ASD Output Frequency**.

Frequency Reference — Displays the **Frequency Setpoint**.

Output Current — Displays the **Output Current** as a percentage of the rated capacity of the H7 ASD.

Bus Voltage — Displays the **Bus Voltage** as a percentage of the rated capacity of the H7 ASD.

Output Voltage — Displays the **Output Voltage** as a percentage of the rated capacity of the H7 ASD.

Input Signal Status — Displays the status of the discrete input lines of the **Control Terminal Strip**.

Out1 Out2 FL — Displays the status of the discrete output lines of the **Control Terminal Strip**.

Timer — Displays the **Cumulative Run Time** in hours.

Postcomp Frequency — Displays the **Output Frequency** after the application of the slip compensation correction value.

Feedback (inst.) — Provides a status of the **Real Time Feedback** in Hz.

Feedback (1 second) — Provides a status of the **1-Second Averaging** feedback in Hz.

Torque — Displays the **Output Torque** as a percentage of the rated capacity of the H7 ASD.

Torque Reference — Displays the **Torque Reference** as a percentage.

Torque Current — Displays the current being used to produce torque.

Excitation Current — Displays the current required to produce the excitation field.

PID Value — Displays the **PID** feedback value in Hz (Proportional-Integral-Derivative).

Motor Overload — Displays the **Motor Overload** value as a percentage of the rated capacity of the motor.

ASD Overload — Displays the **ASD Overload** as a percentage of the rated capacity of the H7 ASD.

DBR Overload — Displays the **DBR Overload** value as a percentage of the **Dynamic Braking Resistor** capacity.

Motor Load — Displays the **Motor Load** in real time as a percentage of the rated capacity of the motor.

ASD Load — Displays the **ASD Load** as a percentage of the rated capacity of the H7 ASD.

DBR Load — Displays the **DBR Load** as a percentage of the **Dynamic Braking Resistor** capacity.

Input Power — Displays the **Input Power** in Kilowatts (Kw).

Output Power — Displays the **Output Power** in Kilowatts (Kw).

Peak Current — Displays the **Peak Current** since the last start was initiated. The current is displayed as a percentage of the rated capacity of the H7 ASD.

Peak Voltage — Displays the **Peak Voltage** since the last start was initiated. The voltage is displayed as a percentage of the rated capacity of the H7 ASD.

PG Speed — Displays the **PG Speed**.

Direction — Displays the **Direction** command (forward/reverse).

PG Position — Displays the **Pulse Generator Position**.

RR — Displays the **RR** input value as a percentage of the full range of the RR value (potentiometer input).

VI/II — Displays the **VI/II** input setting as a percentage of the full range of the **VI/II** value.

Note: The VI/II input represents two analog inputs (and terminals). The VI input terminal is used for a 0 – 10 VDC analog signal and the II input terminal is used for current loop applications, such as with a 4-20 mA signal. Either may be used as a frequency or torque command source; however, the two cannot function simultaneously. Throughout this manual they will be listed as VI/II.

RX — Displays the **RX** input setting as a percentage of the full range of the **RX** value (-10 to +10 VDC input).

RX2 — Displays the **RX2** input setting as a percentage of the full range of the **RX2** value.

Note: The RX2 function is available on the ASD-Multicom option board only.

FM — Displays the output frequency value as a percentage of the full range of the **FM** value.

AM — Displays the output current as a percentage of the full range of the **AM** value.

Option Type — Displays the type form number of the installed **ASD-Multicom** option board.

Option Term A — TBD.

Option Term B — TBD.

Option Term O — TBD.

Option Term P — TBD.

Max. Output — TBD.

Pattern Select — Displays the selected pattern if using **Pattern Run**.

Repeats Left — Displays the number of patterns remaining if using **Pattern Run**.

Pattern — Displays the active **Pattern Run ID** number.

Pattern Time Left — Displays the time remaining in the current pattern if using **Pattern Run**.

Fault Status — Displays the current fault or **No Fault**.

Program Mode

Table 6 lists the menu items of the **Program** mode and maps the flow of the menu selections. The **Parameter Numbers** for the listed functions are provided where applicable. The functions listed may be accessed (and changed) as mapped below or via the **Direct Access** method: Program ⇒ Direct Access ⇒ *Applicable Parameter Number*.

Table 6. Program mode mapping.

Program Menu Navigation			
Primary Menu	Sub Menu	Parameter Name	Parameter Number
FUNDAMENTAL PARAMETERS	Frequency Setting	Maximum Frequency	F011
		Upper Limit	F012
		Lower Limit	F013
		V/f Pattern	F015
	Standard Mode Selection	Command Mode	F003
		Frequency Mode #1	F004
		Frequency Mode #2	F207
		Reference Priority Selection	F200
		Mode #1/#2 Switching Frequency	F208
	Accel/Decel #1 Settings	Accel #1	F009
		Decel #1	F010
		Accel/Decel Pattern	F502
		Automatic Accel/Decel Enable/Disable	F000
	Motor Set #1	#1 Base Frequency	F014
		#1 Max Output Voltage	F306
		#1 Torque Boost	F016
#1 Electronic Thermal Protection Level		F600	
STARTUP WIZARD	(See the section titled Startup Wizard Requirements on pg. 36.)		N/A
CHANGED FROM DEFAULT	(See the section titled Default Setting Changes on pg. 35.)		N/A
DIRECT ACCESS	(See the section titled Direct Access Parameter Information on pg. 60.)		N/A
EOI OPTION SETUPS	Contrast (adjustment)	Darker (highlight Darker and press Enter)	N/A
		Lighter (highlight Lighter and press Enter)	N/A
	Local/Remote Key	Command	N/A
		Frequency	N/A
	Realtime Clock Setup	Date and time setting (requires RTC option)	N/A
	Preferences	Double Click Speed	N/A
		Arrow Speed	N/A
		Encoder Speed	N/A
		Encoder Action	N/A
	Alarm Popups	Overheat Alarm	N/A
Undervoltage Alarm		N/A	

Program Menu Navigation				
Primary Menu	Sub Menu	Parameter Name	Parameter Number	
EOI OPTION SETUPS	Alarm Popups	Over-current Alarm	N/A	
		ASD Overload Alarm	N/A	
		Motor Overload Alarm	N/A	
		Timer	N/A	
		Overtorque Alarm	N/A	
		DBR Resistor Alarm	N/A	
	Lockout	Lockout Reset	N/A	
		Lockout Monitor	N/A	
		Lockout Run/Stop	N/A	
		Lockout Parameter Access	N/A	
		Lockout Parameter Write	N/A	
		Lockout Frequency Change	N/A	
		Lockout Options	N/A	
		Lockout Local/Remote	N/A	
	Password (Enable/Enter)	N/A		
	Review Startup Screen	(displays the Startup screen)	N/A	
	UTILITY PARAMETERS	Versions (read only)	Typeform	N/A
			CPU Version	N/A
CPU Revision			N/A	
EEPROM #1 Version			N/A	
EEPROM #2 Version			N/A	
EOI Version			N/A	
Display Units		User-defined Units Enable/Disable	N/A	
		User-defined Units	N/A	
		Hz Per User-defined Unit	F702	
		Frequency Display Resolution	F703	
		Units for Voltage and Current	F701	
Type Reset		None	F007	
		Auto Setup for 50 Hz		
		Auto Setup for 60 Hz		
		Restore Factory Defaults		
		Clear Trip		
		Clear Run Timer		
		New Base Drive Board		
		Save User Parameters		
		Restore User Parameters		
		Reload EOI Flash		
	Reset EOI Memory			
Comm. Stops During Reset				

Program Menu Navigation			
Primary Menu	Sub Menu	Parameter Name	Parameter Number
TERMINAL SELECTION PARAMETERS	Input Terminal Function	F	F111
		R	F112
		ST	F113
		RES	F114
		S1	F115
		S2	F116
		S3	F117
		S4	F118
		S5	F119
		S6	F120
		S7	F121
		12	F122
		13	F123
		14	F124
		15	F125
		16	F126
		ON	F110
	Output Terminal Functions	Out 1	F130
		Out 2	F131
		FL	F132
		4	F133
		5	F134
		6	F135
		7	F136
	Analog Input Functions	Acc/Dec Base Frequency Adjustment	F650
		Upper-limit Frequency Adjustment	F651
		Acceleration Time Adjustment	F652
		Deceleration Time Adjustment	F653
		Torque Boost Adjustment	F654
	Reach Settings	Low Speed Signal Output Frequency	F100
		Speed Reach Setting Frequency	F101
	FP Terminal Settings	FP Terminal Meter Selection	F676
		FP Terminal Meter Adjustment	F677
	Input Special Functions	ST Signal Selection	F103
		F/R Priority Selection (w/both on)	F105
		Input Terminal Priority	F106
		Extended Terminal Function	F107
	Line Power Switching	(Commercial Power Switching) On Trip Enable/Disable	F354

Program Menu Navigation			
Primary Menu	Sub Menu	Parameter Name	Parameter Number
TERMINAL SELECTION PARAMETERS	Line Power Switching	Switching-Frequency Setting and Enable/Disable	F355
		ASD-Output Switching Wait-Time	F356
		Commercial Input-Power Wait-Time	F357
		Commercial-Power Switching-Frequency Hold-Time	F358
	Input Terminal Delays	F	F140
		R	F141
		ST	F142
		RES	F143
		S1-S4	F144
		S5-S16	F145
	Output Terminal Delays	Out1 On Delay	F150
		Out1 Off Delay	F160
		Out2 On Delay	F151
		Out2 Off Delay	F161
		FL On Delay	F152
		FL Off Delay	F162
		Out4 On Delay	F153
		Out4 Off Delay	F163
		Out5 On Delay	F154
		Out5 Off Delay	F164
Out6 On Delay		F155	
Out6 Off Delay		F165	
Out7 On Delay		F156	
Out7 Off Delay	F166		
FREQUENCY SETTING PARAMETERS	Analog Filter	Analog Input Filter Selection	F209
	Speed Ref. Setpoint	VI/II	F201
		RR	F210
		RX	F216
		RX2	F222
		BIN	F228
		PG	F234
	Jog Settings	Jog Run Frequency	F260
		Jog Stop Control	F261
		Jog Window Enable/Disable	N/A
	Preset Speeds	#1 Frequency & Characteristics	F018
		#2 Frequency & Characteristics	F019
		#3 Frequency & Characteristics	F020
#4 Frequency & Characteristics		F021	

Program Menu Navigation			
Primary Menu	Sub Menu	Parameter Name	Parameter Number
FREQUENCY SETTING PARAMETERS	Preset Speeds	#5 Frequency & Characteristics	F022
		#6 Frequency & Characteristics	F023
		#7 Frequency & Characteristics	F024
		#8 Frequency & Characteristics	F287
		#9 Frequency & Characteristics	F288
		#10 Frequency & Characteristics	F289
		#11 Frequency & Characteristics	F290
		#12 Frequency & Characteristics	F291
		#13 Frequency & Characteristics	F292
		#14 Frequency & Characteristics	F293
	#15 Frequency & Characteristics	F294	
	Preset Speed Mode	Use Preset Speed Enable/Disable	F380
	Fwd/Rev Disable	Disable Forward Run/Disable Reverse Run	F311
	Motorized Pot Settings	Motorized Pot Setting Disposition at Power Down	F108
		Minimum Frequency	N/A
Maximum Frequency		N/A	
PROTECTION PARAMETERS	Dynamic Braking	Dynamic Braking Enable/Disable & Configuration	F304
	Stall	Over-current Stall Level	F601
		Over-voltage Stall Enable/Disable	F305
		Over-voltage Stall Level Configuration	N/A
		Over-voltage Stall Level (Fast)	F625
		Continuing Stall Period (During Positive Torque/Speed)	F452
		Stall Prevention During Regeneration	F454
	DC (Injection) Braking	DC Injection Start Frequency	F250
		DC Injection Braking Current	F251
		DC Injection Braking Time	F252
		Motor Shaft Fixing Control	F253
		Motor Shaft Stationary Control Enable/Disable	F254
	Emergency Off Settings	Emergency Off Mode Configuration	F603
		DC Injection Braking Time	F604
		Emergency Off Activation of the FL Output Enable/Disable	N/A
	Retry/Restart Configuration	Number of Retries	F303
		Restart Conditions	F301
		Scan Rate	F312
		Lock-on Rate	F313
		Search Method	F314
		Search Inertia	F315

Program Menu Navigation			
Primary Menu	Sub Menu	Parameter Name	Parameter Number
PROTECTION PARAMETERS	Undervoltage/ Ridethrough	Ridethrough Mode	F302
		Ridethrough Time	F310
		Undervoltage Stall Level	F629
		Undervoltage Trip Enable/Disable	F627
		Undervoltage Detection Time	F628
	Overload	OL Reduction Starting Frequency	F606
		Motor 150% OL Time Limit	F607
		Soft Stall Enable/Disable	F017
		Motor Overload Trip Enable/Disable	N/A
		V/f Motor Enable/Disable	N/A
	Trip Settings	Trip Save at Power Down Enable/Disable	F602
	Cooling Fan Control	Cooling Fan Control Mode	F620
	Cumulative Run Timer	Cumulative Run Timer Alarm Setting	F621
	Phase Loss	Output Phase Loss Detection Enable/Disable	F605
	Low Current Settings	Low Current Trip/Alarm Configuration	F610
	Abnormal Speed Settings	Abnormal Speed Detection Filter Time	F622
		Overspeed Detection Frequency Range	F623
		Speed Drop Detection Frequency Range	F624
	Short Circuit Detect Pulse	Short-Circuit-Pulse Run Command	F613
		Short-Circuit-Pulse Run Duration	F614
	Overtorque Settings	Overtorque Trip Enable/Disable	F615
		Overtorque Trip/Alarm Level During Power Operation	F616
		Overtorque Trip/Alarm Level During Regeneration	F617
		Overtorque Detection Time	F618
	Brake Fault Timer	Braking Trouble Internal Timer	F630
		Release After Run Timer	F632
	Base Frequency Voltage	Supply Voltage Compensation Enable/Disable	F307
		Output Voltage Limitation Enable/Disable	
	Soft Start	Suppression of Inrush-Current Timing	F608
		Interlock with ST	F609
TORQUE SETTING PARAMETERS	Set Points	VI/II	F205
		RR	F214
		RX	F220
		RX2	F226
		BIN	F232
	Torque Control	Torque Command Selection	F420
		Torque Command Filter	F421
		Synchronized Torque Bias Input Selection	F422

Program Menu Navigation			
Primary Menu	Sub Menu	Parameter Name	Parameter Number
TORQUE SETTING PARAMETERS	Torque Control	Tension Torque Bias Input Selection	F423
		Load Sharing Gain Input Selection	F424
	Torque Limit Settings	Positive Torque Limit #1 Selection	F440
		Negative Torque Limit #1 Selection	F442
		Manual Settings	F441
		Torque Limit Mode	F450
		Torque Limit Mode (speed dependent)	F451
	Manual Torque Limit Settings	#1 Positive/Negative Torque Limit Settings	F441
		#2 Positive/Negative Torque Limit Settings	F444
		#3 Positive/Negative Torque Limit Settings	F446
		#4 Positive/Negative Torque Limit Settings	F448
	Torque Speed Limiting	Torque Command Mode Selection	F429
		Forward Speed Limit Selection	F425
		Forward Speed Limit Level	F426
		Reverse Speed Limit Selection	F427
		Reverse Speed Limit Level	F428
		Speed Limit Torque Reference Selection	F430
		Speed Limit Torque Level	F431
		Speed Limit Torque Band	F432
Speed Limit Torque Recovery Time		F433	
FEEDBACK PARAMETERS	Feedback Settings	Input Selection	F360
		Proportional (P) Gain	F362
		Integral (I) Gain	F363
		Differential (D) Gain	F366
		Delay Filter	F361
		Deviation Limits	F364
		Position Difference Limit	F631
	PG Settings	Number of PG Input Pulses	F367
		PG Input Phases	F368
		PG Disconnection Detection Selection	F369
		Electronic Gear Setting	F370
		Position Loop Gain	F371
		Positioning Completion Range	F372
		Frequency Limit at Position	F373
		Current Control Proportional Gain	F374
		Current Control Integral Gain	F375
		Speed Loop Proportional Gain	F376
		Speed Loop Integral Gain	F377
		Motor Counter Data Selection	F378
		Speed Loop Parameter Ratio	F379

Program Menu Navigation			
Primary Menu	Sub Menu	Parameter Name	Parameter Number
FEEDBACK PARAMETERS	Drooping Control	Drooping Gain 100%	F320
		Speed at Drooping Gain 0%	F321
		Speed at Drooping Gain 100%	F322
		Drooping Insensitive Torque Band	F323
		Drooping Output Filter	F324
		Drooping Reference	F327
		Load Inertia (Acc/Dec Torque)	F325
		Load Torque Filter	F326
	Override Control	Adding Input Selection	F660
		Multiplying Input Selection	F661
LED Option Override Multiplication Gain		F729	
PATTERN RUN CONTROL PARAMETERS	Pattern Run	Pattern Run Mode Enable/Disable and Restart Configuration	F520
	Speeds	Pattern #1 Speeds	F530
		Pattern #2 Speeds	F540
		Pattern #3 Speeds	F550
		Pattern #4 Speeds	F560
	Preset Speeds	#1 Frequency & Characteristics	F018
		#2 Frequency & Characteristics	F019
		#3 Frequency & Characteristics	F020
		#4 Frequency & Characteristics	F021
		#5 Frequency & Characteristics	F022
		#6 Frequency & Characteristics	F023
		#7 Frequency & Characteristics	F024
		#8 Frequency & Characteristics	F287
		#9 Frequency & Characteristics	F288
		#10 Frequency & Characteristics	F289
		#11 Frequency & Characteristics	F290
		#12 Frequency & Characteristics	F291
		#13 Frequency & Characteristics	F292
#14 Frequency & Characteristics	F293		
#15 Frequency & Characteristics	F294		
Preset Speed Mode	Use Preset Speed Enable/Disable	F380	
COMMUNICATION SETTING PARAMETERS	Communication Settings	ASD Number	F802
		Logic (TTL) Baud Rate	F800
		RS232/RS485 Baud Rate	F820
		Parity	F801
		RS232/RS485 Communication Time Out Time	F803
		Logic (TTL) Communication Time Out Action	F804
		RS232/RS485 Communication Time Out Action	N/A

Program Menu Navigation			
Primary Menu	Sub Menu	Parameter Name	Parameter Number
COMMUNICATION SETTING PARAMETERS	Communication Settings	Communication Interval (logic)	F805
		RS232/RS485 Wire Count	F821
		RS232/RS485 Response Time	F825
		TTL Master Output Selection	F806
		RS232/RS485 Master Output Selection	F826
		LCD Port Connection Type	N/A
	Communication Reference Adjust	Frequency Point Selection	F810
	S20 Settings	Receive Address	F860
		Transmit Address	F861
		Speed Reference Station	F862
		Speed Reference Address	F863
		Torque Reference Station	F865
		Torque Reference Address	F866
		Fault Detect Station Number	F868
		Station Mode	F869
		S20 Reset	F899
		Error Mode	F850
		Error Detect Time	F851
	Scan Receive Settings	#1 Scan Receive	F831
		#2 Scan Receive	F832
		#3 Scan Receive	F833
		#4 Scan Receive	F834
		#5 Scan Receive	F835
		#6 Scan Receive	F836
	Scan Transmit Settings	#1 Scan Transmit	F841
		#2 Scan Transmit	F842
		#3 Scan Transmit	F843
		#4 Scan Transmit	F844
		#5 Scan Transmit	F845
		#6 Scan Transmit	F846
	Communication Error	Command Request Disposition on Error	F830
	Optional Parameters	Optional Parameter #1	F890
		Optional Parameter #2	F891
Optional Parameter #3		F892	
Optional Parameter #4		F893	
Optional Parameter #5		F894	

Program Menu Navigation				
Primary Menu	Sub Menu	Parameter Name	Parameter Number	
METER TERMINAL ADJUSTMENT PARAMETERS	FM	FM Terminal Assignment	F005	
		FM Terminal Adjustment	F006	
	AM	AM Terminal Assignment	F670	
		AM Terminal Adjustment	F671	
	Analog1	Analog 1 Terminal Assignment	F672	
		Analog 1 Terminal Adjustment	F673	
	Analog2	Analog 2 Terminal Assignment	F674	
		Analog 2 Terminal Adjustment	F675	
	MOTOR PARAMETERS	Vector Motor Model	AutoTune Enable/Disable and Reset Config.	F400
			AutoTune Enable/Disable of Motor Constant 3	F414
Slip Frequency Gain			F401	
Motor Constant 1 (primary resistance)			F402	
Motor Constant 2 (secondary resistance)			F403	
Motor Constant 3 (exciting inductance)			F404	
Motor Constant 4 (load inertia)			F405	
Motor Constant 5 (leakage inductance)			F410	
Motor Settings		Number of Motor Poles	F411	
		Motor Capacity (kW)	F412	
		Motor Type	F413	
Motor Set #1		#1 Base Frequency	F014	
		#1 Max Output Voltage	F306	
		#1 Torque Boost	F016	
		#1 Electronic Thermal Protection Level	F600	
Motor Set #2		#2 Base Frequency	F170	
		#2 Max Output Voltage	F171	
		#2 Torque Boost	F172	
		#2 Electronic Thermal Protection Level	F173	
Motor Set #3		#3 Base Frequency	F174	
		#3 Max Output Voltage	F175	
		#3 Torque Boost	F176	
		#3 Electronic Thermal Protection Level	F177	
Motor Set #4		#4 Base Frequency	F178	
		#4 Max Output Voltage	F179	
		#4 Torque Boost	F180	
		#4 Electronic Thermal Protection Level	F181	
MONITOR SETUP		Trip History	Trip History Records	N/A
		Trip Monitor from ASD	Most Recent	N/A
			Second Most Recent	N/A
			Third Most Recent	N/A

Program Menu Navigation			
Primary Menu	Sub Menu	Parameter Name	Parameter Number
MONITOR SETUP	Trip Monitor From ASD	Fourth Most Recent	N/A
	Scrolling Monitor Select	Scrolling Monitor Select	N/A
SPECIAL CONTROL PARAMETERS	Frequency Control	Start Frequency	F240
		End Frequency	F243
		Run Frequency	F241
		Run Frequency Hysteresis	F242
	Jump Frequencies	Jump Frequency Bandwidth Settings	F271
		Jump Frequency Processing Selection	F276
	Carrier Frequency	PWM Carrier Frequency Setting	F300
	Accel/Decel #1 – #4 Settings	Accel/Decel/Pattern #1 Configuration	F009
		Accel/Decel/Pattern #2 Configuration	F500
		Accel/Decel/Pattern #3 Configuration	F510
		Accel/Decel/Pattern #4 Configuration	F514
	Accel/Decel Special	S-Pattern Lower Limit Adjustment	F506
		S-Pattern Upper Limit Adjustment	F507
		Accel/Decel Time Lower Limit	F508
		Accel/Decel Switching Frequency #1	F505
		Accel/Decel Switching Frequency #2	F513
		Accel/Decel Switching Frequency #3	F517
		Accel/Decel Display Resolution	F704
	Crane/Hoist Load	High-Speed Operation at Light Load	F330
		Light-load High-speed Operation Switching Lower Limit Frequency	F331
		Light-load High-speed Operation Load Waiting Time	F332
		Light-load High-speed Operation Load Detection Time	F333
		Light-load High-speed Operation Heavy Load Detection Time	F334
		Switching Load Torque During Forward Run	F335
		Heavy Load Torque During Acceleration in the Forward Direction	F336
		Heavy Load Torque During Fixed Speed in the Forward Direction	F337
		Switching Load Torque During Reverse Run	F338
		Heavy Load Torque During Acceleration in the Reverse Direction	F339
		Heavy Load Torque During Fixed Speed in the Reverse Direction	F340
		Frequency for Automatic High-speed Operation at Light Load	F341
		Backlash Setup	Not available at the time of this release.

Program Menu Navigation			
Primary Menu	Sub Menu	Parameter Name	Parameter Number
SPECIAL CONTROL PARAMETERS	V/f Five Point Setting	#1 Frequency Setting	F190
		#1 Voltage Setting	F191
		#2 Frequency Setting	F192
		#2 Voltage Setting	F193
		#3 Frequency Setting	F194
		#3 Voltage Setting	F195
		#4 Frequency Setting	F196
		#4 Voltage Setting	F197
		#5 Frequency Setting	F198
		#5 Voltage Setting	F199
	Low Output Disable Function	LOD Control and Stopping Method	F731
		LOD Start Level	F732
		LOD Start Time	F733
		LOD Setpoint Boost	F734
		LOD Boost Time	F735
		LOD Feedback Level	F736
		LOD Restart Delay Time	F737
	Earth Fault	Earth Fault Alarm Level	F640
		Earth Fault Alarm Time	F641
		Earth Fault Trip Level	F642
		Earth Fault Trip Time	F643
	Special Parameters	V/f Adjustment Coefficient	F183
		0 Hz Dead Band Frequency Setting Signal	F244
		0 Hz Command Stop Function	F255
		Over Exciting Cooperation	F481
		Stall Cooperation Gain at Field Weakening Zone	F485
		Exciting Starting Rate	N/A
		Compensation Coefficient for Iron Loss	F487
		Voltage Compensation Coefficient for Dead Time	N/A
		Dead Time Compensation Enable/Disable	F489
		Dead Time Compensation Bias	F490
		Switching Frequency Between Current and Voltage	F491
		Optional Analog Terminal Mark	N/A
		Current Differential Gain	F454
		Exciting Strengthening Coefficient	F480
		Enable/Disable User Parameter Initialization During Typeform Initialization	F709
		% Current Vector Control	F482
% Voltage Vector Control	F483		
% Constant Vector Control	F484		

Direct Access Parameter Information

The **H7 ASD** has the ability to allow the user direct access to the motor control functions. The functions listed below have an associated **Parameter Number** which accesses its setting. There are two ways in which the motor-control parameters may be accessed for modification: Program ⇒ *applicable menu path* or Program ⇒ Direct Access ⇒ *applicable parameter number*. Both methods access the parameter via the **Program** mode. Once accessed, the parameter may be viewed or changed.

The **Program** mode allows the user to develop an application-specific motor control profile. Motor control functions may be set to accommodate specific power and timing requirements for a given application. The configurable parameters of the **Program** mode that have user-accessible **Parameter Numbers** are listed and described below.

*Note: The setup procedures included within this section may require a **Reset** before performing the procedure. Application-specific settings may then be performed. The pre-Reset conditions may be saved (see F007).*

Direct Access Parameters/Numbers

Automatic Accel/Decel #1

Program ⇒ Fundamental Parameters ⇒ **Accel/Decel #1 Settings**

This parameter **Enables/Disables** the ability of the ASD to adjust the acceleration and deceleration rates in accordance with the applied load automatically.

The adjusted acceleration and deceleration times range from 12.5% to 800% of the programmed values for **Acceleration Time #1 (F009)** and **Deceleration Time #1 (F010)**.

Settings:

- Disabled
- Enabled (box checked)

*Note: The motor and the load must be connected prior to selecting **Automatic Accel/Decel**.*

Direct Access Number — F000

Parameter Type — **Check Box**

Factory Default — **Disabled**

Changeable During Run — **No**

Command Mode Selection

Program ⇒ Fundamental Parameters ⇒ Standard Mode Selection ⇒ **Command Mode**

The **Command Mode Selection** establishes the source of the command input for the ASD. **Command** inputs include **Run, Stop, Forward**, etc. The **Override** feature may supersede the **Command Mode Selection** setting (see [Command Mode and Frequency Mode Control on pg. 39](#)).

Settings:

- Use Control Terminal Strip
- Use LED Keypad Option
- Use Common Serial (TTL)
- Use RS232/RS485
- Use Communication Card

Direct Access Number — F003

Parameter Type — **Selection List**

Factory Default — **Use Control Terminal Strip**

Changeable During Run — **No**

Frequency Mode #1

Program ⇒ Fundamental Parameters ⇒ Standard Mode Selection ⇒
Frequency Mode #1

The **Frequency Mode #1** setting establishes the source of the frequency-control input for the ASD. The **Override** feature may supersede the **Frequency Mode #1** setting (see [Command Mode and Frequency Mode Control on pg. 39](#)).

*Note: Only **Bolded** items from the **Settings** list below may be placed in the **Override** mode. See the section titled [Command Mode and Frequency Mode Control on pg. 39](#) for further information on the **Override** feature.*

Settings:

Use VI/II

Use RR

Use RX

Use Option Card RX2

Use LED Keypad Option

Use Binary/BCD Input

Use Common Serial (TTL)

Use RS232/RS485

Use Communication Card

Use Motorized Pot. Simulation

Use Pulse Input Option

Direct Access Number — F004

Parameter Type — Selection List

Factory Default — Use RR

Changeable During Run — No

FM Terminal Assignment

Program ⇒ Meter Terminal Adjustment Parameters ⇒ **FM**

This setting determines the output function of the **FM** analog output terminal. The **FM** output terminal produces an output current that is proportional to the magnitude of the function assigned to this terminal. The available assignments for this output terminal are listed in [Table 7 on pg. 62](#).

*Note: To read **voltage** at this terminal a 100 – 500Ω resistor is required and it must be connected from FM (+) to FM (-). The voltage is read across the 100 – 500Ω resistor.*

Current may be read by connecting an ammeter from FM (+) to FM (-).

The **FM** analog output has a maximum resolution of 1/1024. The **FM Terminal Adjustment (F006)** must be used to calibrate the output signal for a proper response. **SW-2** may be switched to allow for the full-range output to be either 0 – 1 mA or 4 – 20 mA when providing an output current, or either 0 – 1 or 1 – 7.5 volts when providing an output voltage at this terminal.

Direct Access Number — F005

Parameter Type — Selection List

Factory Default — Output Frequency

Changeable During Run — Yes

FM Terminal Adjustment

Program ⇒ Meter Terminal Adjustment Parameters ⇒ **FM**

This function is used to calibrate the **FM** analog output terminal.

To calibrate the **FM** analog output, connect a meter (current or voltage) as described at **F005**. With the drive running at a known frequency, adjust this parameter (**F006**) until the running frequency produces the desired DC level output at the **FM** terminal.

Direct Access Number — F006

Parameter Type — Numerical

Factory Default — 512

Changeable During Run — Yes

Minimum — 0

Maximum — 1280

The magnitude of the AM/FM output signal at full-scale is selection-specific and may be adjusted (see **F671** and **F006**) to fit application-specific requirements. **Table 7** shows the default full-scale output setting of the AM/FM terminal for each selection. The column on the right side of **Table 7** shows the actual AM/FM output for an EOI display of 100% (default setting).

Table 7. Output terminal selections for the **AM, FM, FP**, and **Analog 1 & 2** terminals.

Function	AM/FM Output Value at 100% EOI-Displayed Output	
Output Frequency (FM and FP default setting)	Maximum Frequency	
Frequency Reference		
Output Current (AM default setting)	150%	
DC Bus Voltage		
Output Voltage (Analog 1 default setting)		
Post-compensation Frequency (Analog 2 default setting)	Maximum Frequency	
Speed Feedback (realtime)		
Speed Feedback (1 sec filter)		
Torque	150%	
Torque Command		
Internal Torque Base		
Torque Current		
Excitation Current		
PID Feedback Value	Maximum Frequency	
Motor Overload Ratio	Motor Overload Trip Point Setting	
ASD Overload Ratio	ASD Overload Trip Point Setting	
PBR (DBR) Overload Ratio	DBR Overload Trip Point Setting	
PBR (DBR) Load Ratio	Maximum DBR Duty Cycle	
Input Power	1.73 * input voltage * ASD rated current	
Output Power		
Peak Output Current	150%	
Peak DC Bus Voltage		
PG Counter	32767 Encoder Pulses	
Position Pulse		
RR Input	100%	
VI/II Input		
RX Input		
RX2 Input		
FM Output (used for factory testing only)		
AM Output (used for factory testing only)		
Meter Adjust Value		
Analog Output		
Load Torque		150%

F007

F008

Type ResetProgram ⇒ Utility Parameters ⇒ **Type Reset**

This feature assists the user when performing fault analysis or by allowing a quick system setup change when required. Performing a **Type Reset** results in one of the following user-selected post-reset configurations.

Settings:

- None
- Auto Setup for 50 Hz
- Auto Setup for 60 Hz
- Restore Factory Defaults
- Clear Trip
- Clear Run Timer
- New Base Drive Board
- *Save User Parameters
- Restore User Parameters
- Reload EOI Flash
- Reset EOI Memory

Note: *User settings that are stored in the memory of the EOI are not saved via the **Save User Parameters** selection. The unsaved functions include the **EOI Option Setups**, (Utility Parameters ⇒) **Display Units**, and (Monitor Setup ⇒) **Scrolling Monitor Select**.

Direct Access Number — F007Parameter Type — **Selection List**Factory Default — **None**Changeable During Run — **No****Direction (of motor rotation)**

No path available (Direct Access Only)

While operating using the **LED Keypad Option** this parameter sets the direction of motor rotation. This setting may be changed during operation. This setting will not override parameter **F311 (Forward/Reverse Disable)**.

If either direction is disabled via parameter **F311**, the disabled direction will not be recognized if commanded by the **LED Keypad**. If both directions are disabled via parameter **F311**, the direction command from the **LED Keypad** will determine the direction of the motor rotation.

Settings:

- Forward
- Reverse

Note: If using the **LCD EOI**, press **ESC** from the **Frequency Command** screen to access the **Motor Direction** parameter.

Direct Access Number — F008Parameter Type — **Selection List**Factory Default — **Forward**Changeable During Run — **Yes**

<p>Accel #1 Time</p> <p>Program ⇒ Fundamental Parameters ⇒ Accel/Decel #1 Settings</p> <p>This parameter specifies the time in seconds for the drive to go from 0.0 Hz to the Maximum Frequency for the #1 Acceleration profile. The accel/decel pattern may be set using F502. The minimum accel/decel time may be set using F508.</p> <p><i>Note:</i> An acceleration time shorter than the load will allow may cause nuisance tripping and mechanical stress to loads. Automatic Accel/Decel and Stall settings may lengthen the acceleration time.</p> <p>Acceleration</p> <p>The acceleration rate of a motor is determined by several factors: applied power, applied load, and the physical properties of the motor (winding parameters, motor size, etc.). The ASD will control the first of these factors: input power. The settings of the ASD control the frequency and amplitude of the applied voltage to the motor.</p> <p>Under most operating conditions, as the output frequency of the drive goes up so does the output voltage (linear acceleration). The ASD has the ability to modify the relationship between frequency and voltage automatically to produce smoother operation or increased (starting) torque.</p>	<p>Direct Access Number — F009</p> <p>Parameter Type — Numerical</p> <p>Factory Default — (ASD-dependent)</p> <p>Changeable During Run — Yes</p> <p>Minimum — 0.1</p> <p>Maximum — 6000</p> <p>Units — Seconds</p>
<p>Decel #1 Time</p> <p>Program ⇒ Fundamental Parameters ⇒ Accel/Decel #1 Settings</p> <p>This parameter specifies the time in seconds for the drive to go from the Maximum Frequency to 0.0 Hz for the #1 Deceleration profile. The accel/decel pattern may be set using F502.</p> <p>When operating with the Automatic Accel/Decel enabled (F000) the minimum accel/decel time may be set using F508.</p> <p><i>Note:</i> A deceleration time shorter than the load will allow may cause nuisance tripping and mechanical stress to loads. Automatic Accel/Decel and Stall settings may lengthen the acceleration time.</p>	<p>Direct Access Number — F010</p> <p>Parameter Type — Numerical</p> <p>Factory Default — (ASD-dependent)</p> <p>Changeable During Run — Yes</p> <p>Minimum — 0.1</p> <p>Maximum — 6000</p> <p>Units — Seconds</p>
<p>Maximum Frequency</p> <p>Program ⇒ Fundamental Parameters ⇒ Frequency Settings</p> <p>This setting determines the absolute maximum frequency that the ASD can output. This setting is also referred to as FH.</p> <p>Accel/decel times are calculated based on the Maximum Frequency setting.</p> <p><i>Note:</i> This setting may not be lower than the Upper Limit setting (F012).</p>	<p>Direct Access Number — F011</p> <p>Parameter Type — Numerical</p> <p>Factory Default — 80.0</p> <p>Changeable During Run — No</p> <p>Minimum — 30.0</p> <p>Maximum — 299.0</p> <p>Units — Hz</p>
<p>Upper Limit Frequency</p> <p>Program ⇒ Fundamental Parameters ⇒ Frequency Settings</p> <p>This parameter sets the highest frequency that the ASD will accept as a frequency command or frequency setpoint. The ASD may output frequencies higher than the Upper Limit Frequency (but, lower than the Maximum Frequency) when operating in the PID Control mode, Torque Control mode, or the Vector Control modes (sensorless or feedback).</p> <p><i>Note:</i> This setting may not be higher than the Maximum Frequency (F011) setting.</p>	<p>Direct Access Number — F012</p> <p>Parameter Type — Numerical</p> <p>Factory Default — 80.0</p> <p>Changeable During Run — Yes</p> <p>Minimum — 0.0</p> <p>Maximum — Max. Freq. (F011)</p> <p>Units — Hz</p>

Lower Limit Frequency

Program ⇒ Fundamental Parameters ⇒ **Frequency Settings**

This parameter sets the lowest frequency that the ASD will accept as a frequency command or frequency setpoint. The ASD will output frequencies lower than the **Lower Limit Frequency** when accelerating to the lower limit or decelerating to a stop. Frequencies below the **Lower Limit** may also be output when operating in the **PID Control** mode, **Torque Control** mode, or the **Vector Control** modes (sensorless or feedback).

Direct Access Number — F013

Parameter Type — **Numerical**

Factory Default — **0.0**

Changeable During Run — **Yes**

Minimum — 0.0

Maximum — **Upper Limit (F012)**

Units — Hz

Motor #1 Base Frequency

Program ⇒ Fundamental Parameters ⇒ **Motor Set #1**

The **Base Frequency** setting determines the frequency at which the output voltage of the ASD reaches its maximum setting. The maximum voltage setting cannot be more than the input voltage (see **Maximum Output Voltage** at **F306**). There are four **Base Frequency** profile settings: #1 – #4.

Note: For proper motor operation, the **Base Frequency** is normally set for the name-plated frequency of the motor.

Direct Access Number — F014

Parameter Type — **Numerical**

Factory Default — **60.0**

Changeable During Run — **Yes**

Minimum — 25.0

Maximum — 299.0

Units — Hz

V/f Pattern

Program ⇒ Fundamental Parameters ⇒ **Frequency Settings**

This function establishes the relationship between the output frequency and the output voltage.

Settings:

- Constant Torque
- Variable Torque
- Automatic Torque Boost
- Sensorless Vector Control (speed)
- Auto Torque Boost with Automatic Energy Savings
- Sensorless Vector Control (speed) with Automatic Energy Savings
- V/f 5-Point Setting (opens 5-point setting screen)
- Sensorless Vector Control (speed/torque switching)
- PG Feedback Vector Control (speed/torque switching)
- PG Feedback Vector Control (speed/position switching)

Note: For proper operation, the carrier frequency must be 2.2 kHz or above except while operating in the **Constant Torque**, **Variable Torque**, or the **5-Point Setting** modes.

The **Automatic Torque Boost** and the **Sensorless Vector Control** selections use the motor tuning parameters of the drive to properly configure the ASD for the motor being used. If **Load Reactors** or **Long Lead Filters** are used, or if the capacity of the ASD is greater than the motor, manual tuning of the motor parameters may be required for optimum performance.

Direct Access Number — F015

Parameter Type — **Selection List**

Factory Default — **Constant Torque**

Changeable During Run — **No**

F016

F017

Motor #1 Torque BoostProgram ⇒ Fundamental Parameters ⇒ **Motor Set #1**

The **Motor #1 Torque Boost** function is used to increase the low frequency torque for high-inertia loads by increasing the output voltage at frequencies below ½ of the **#1 Base Frequency (F014)** setting.

The value programmed as a boost percentage establishes an output voltage vs. output frequency relationship to be used to start the motor or to provide smoother operation.

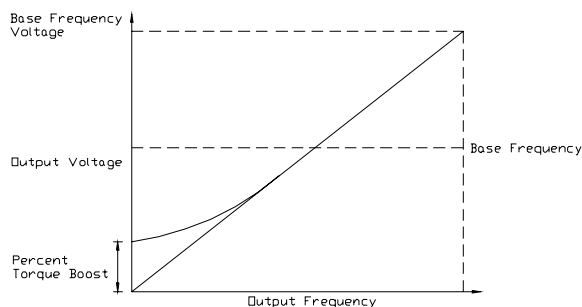

Note: Setting an excessive **Torque Boost** level may cause nuisance tripping and mechanical stress to loads.

Soft StallProgram ⇒ Protection Parameters ⇒ **Overload**

This parameter **Enables/Disables** the **Soft Stall** function. When enabled, the **Soft Stall** function reduces the output frequency of the ASD when the current requirements of the motor exceed the **Electronic Thermal Protection #1** setting (**F600**); thus, reducing the output current.

If the current drops below the motor overload protection level setting within a specified time, the output of the ASD will accelerate to the programmed frequency setpoint. If not, a trip will be incurred.

The **Soft Stall** feature is available when the (Program ⇒ Protection Parameters ⇒ Overload ⇒) **Motor Overload Trip Enable/Disable** parameter is enabled only.

Soft Stall is highly effective in preventing motor overload trips when used on fans, blowers, pumps, and other centrifugal loads which require less torque at lower frequencies.

Note: The **Soft Stall** setting may affect acceleration times and patterns.

Settings:

- Disabled
- Enabled (box checked)

Direct Access Number — F016Parameter Type — **Numerical**Factory Default — **(ASD-dependent)**Changeable During Run — **Yes**

Minimum — 0.0

Maximum — 30.0

Units — %

Direct Access Number — F017Parameter Type — **Check Box**Factory Default — **Disabled**Changeable During Run — **No**

Preset Speed #1

Program ⇒ Pattern Run Control ⇒ Preset Speeds ⇒ 1

Up to 15 output frequency values that fall within the **Lower Limit** and the **Upper Limit** range may be programmed into the drive and output as a **Preset Speed**. This parameter assigns an output frequency to binary number 0001 and is identified as **Preset Speed #1**. The binary number is applied to **S1 – S4** of the **Control Terminal Strip** to output the **Preset Speed**.

Perform the following setup to allow the system to receive **Preset Speed** control input at the **S1 – S4** terminals:

1. Program ⇒ Fundamental Parameters ⇒ Standard Mode Selection ⇒ **Use Control Terminal Strip**.
2. Program ⇒ Terminal Selection Parameters ⇒ Input Terminals ⇒ **S1** (set to **Preset Speed Command 1**; LSB of 4-bit count). Repeat for **S2 – S4** (MSB of 4-bit count) as **Preset Speed Command 2 – 4**, respectively (all **Normally Open**).

Note: The default setting of **S4** is **EOff**, but this terminal may be re-assigned as the **MSB**.

3. Program ⇒ Frequency Setting Parameters ⇒ Preset Speeds ⇒ 1 (press **Enter** twice and set an output frequency as **Preset Speed #1**; repeat for **Preset Speeds 2 – 15** as required).
4. Program ⇒ Frequency Setting Parameters ⇒ Preset Speed Mode ⇒ **Use Speed Modes (Enable/Disable)**.

When **Enabled**, the direction, accel/dec, and torque settings of the **Preset Speed** being run are used.

When **Disabled**, only the speed setting of the **Preset Speed** being run is used.

5. Place the system in the **Remote** mode (**Local|Remote** LED Off).
6. Provide a **Run** command (connect **F** and/or **R** to **CC**).

Connect **S1** to **CC** to run **Preset Speed #1** (**S1** to **CC** = 0001 binary).

With **S1 – S4** configured to output **Preset Speeds (F115 – F118)**, 0001 – 1111 may be applied to **S1 – S4** of the **Control Terminal Strip** to run the associated **Preset Speed**. If bidirectional operation is required, **F** and **R** must be connected to **CC**, and **Use Speed Modes** must be enabled at **F380**.

With **S1** being the least significant bit of a binary count, the **S1 – S4** settings will produce the programmed speed settings as indicated in the Preset Speed Truth Table to the right.

Preset Speeds are also used in the **Pattern Run** mode.

Preset Speed #2

Program ⇒ Pattern Run Control ⇒ Preset Speeds ⇒ 2

This parameter assigns an output frequency to binary number 0010 and is identified as **Preset Speed #2**. The binary number is applied to **S1 – S4** of the **Control Terminal Strip** to output the **Preset Speed** (see **F018** for further information on this parameter).

Direct Access Number — F018

Parameter Type — **Numerical**

Factory Default — **0.0**

Changeable During Run — **Yes**

Minimum — **Lower Limit (F013)**

Maximum — **Upper Limit (F012)**

Units — Hz

Preset Speed Truth Table.

Preset	S4 MSB	S3	S2	S1 LSB	Output
1	0	0	0	1	F018
2	0	0	1	0	F019
3	0	0	1	1	F020
4	0	1	0	0	F021
5	0	1	0	1	F022
6	0	1	1	0	F023
7	0	1	1	1	F024
8	1	0	0	0	F287
9	1	0	0	1	F288
10	1	0	1	0	F289
11	1	0	1	1	F290
12	1	1	0	0	F291
13	1	1	0	1	F292
14	1	1	1	0	F293
15	1	1	1	1	F294

Note: 1 = Terminal connected to **CC**.

Direct Access Number — F019

Parameter Type — **Numerical**

Factory Default — **0.0**

Changeable During Run — **Yes**

Minimum — **Lower Limit (F013)**

Maximum — **Upper Limit (F012)**

Units — Hz

<p>Preset Speed #3</p> <p>Program ⇒ Pattern Run Control ⇒ Preset Speeds ⇒ 3</p> <p>This parameter assigns an output frequency to binary number 0011 and is identified as Preset Speed #3. The binary number is applied to S1 – S4 of the Control Terminal Strip to output the Preset Speed (see F018 for further information on this parameter).</p>	<p>Direct Access Number — F020</p> <p>Parameter Type — Numerical</p> <p>Factory Default — 0.0</p> <p>Changeable During Run — Yes</p> <p>Minimum — Lower Limit (F013)</p> <p>Maximum — Upper Limit (F012)</p> <p>Units — Hz</p>
<p>Preset Speed #4</p> <p>Program ⇒ Pattern Run Control ⇒ Preset Speeds ⇒ 4</p> <p>This parameter assigns an output frequency to binary number 0100 and is identified as Preset Speed #4. The binary number is applied to S1 – S4 of the Control Terminal Strip to output the Preset Speed (see F018 for further information on this parameter).</p>	<p>Direct Access Number — F021</p> <p>Parameter Type — Numerical</p> <p>Factory Default — 0.0</p> <p>Changeable During Run — Yes</p> <p>Minimum — Lower Limit (F013)</p> <p>Maximum — Upper Limit (F012)</p> <p>Units — Hz</p>
<p>Preset Speed #5</p> <p>Program ⇒ Pattern Run Control ⇒ Preset Speeds ⇒ 5</p> <p>This parameter assigns an output frequency to binary number 0101 and is identified as Preset Speed #5. The binary number is applied to S1 – S4 of the Control Terminal Strip to output the Preset Speed (see F018 for further information on this parameter).</p>	<p>Direct Access Number — F022</p> <p>Parameter Type — Numerical</p> <p>Factory Default — 0.0</p> <p>Changeable During Run — Yes</p> <p>Minimum — Lower Limit (F013)</p> <p>Maximum — Upper Limit (F012)</p> <p>Units — Hz</p>
<p>Preset Speed #6</p> <p>Program ⇒ Pattern Run Control ⇒ Preset Speeds ⇒ 6</p> <p>This parameter assigns an output frequency to binary number 0110 and is identified as Preset Speed #6. The binary number is applied to S1 – S4 of the Control Terminal Strip to output the Preset Speed (see F018 for further information on this parameter).</p>	<p>Direct Access Number — F023</p> <p>Parameter Type — Numerical</p> <p>Factory Default — 0.0</p> <p>Changeable During Run — Yes</p> <p>Minimum — Lower Limit (F013)</p> <p>Maximum — Upper Limit (F012)</p> <p>Units — Hz</p>
<p>Preset Speed #7</p> <p>Program ⇒ Pattern Run Control ⇒ Preset Speeds ⇒ 7</p> <p>This parameter assigns an output frequency to binary number 0111 and is identified as Preset Speed #7. The binary number is applied to S1 – S4 of the Control Terminal Strip to output the Preset Speed (see F018 for further information on this parameter).</p>	<p>Direct Access Number — F024</p> <p>Parameter Type — Numerical</p> <p>Factory Default — 0.0</p> <p>Changeable During Run — Yes</p> <p>Minimum — Lower Limit (F013)</p> <p>Maximum — Upper Limit (F012)</p> <p>Units — Hz</p>
<p>Low Speed Signal Output Frequency</p> <p>Program ⇒ Terminal Selection Parameters ⇒ Reach Settings</p> <p>The Low Speed Signal Output Frequency parameter sets a frequency threshold that activates the assigned output terminal so long as the ASD output is at or above this setting (see Table 9 on pg. 82 for the available output assignments).</p>	<p>Direct Access Number — F100</p> <p>Parameter Type — Numerical</p> <p>Factory Default — 0.0</p> <p>Changeable During Run — Yes</p> <p>Minimum — 0.0</p> <p>Maximum — Max. Freq. (F011)</p> <p>Units — Hz</p>

Speed Reach FrequencyProgram ⇒ Terminal Selection Parameters ⇒ **Reach Settings**

The **Speed Reach Frequency** sets a frequency threshold that, when reached or is within the bandwidth specified by parameter **F102**, will provide a signal at an output terminal that can close an appropriately configured output contact (see [Table 9 on pg. 82](#) for the available output assignments).

Direct Access Number — F101Parameter Type — **Numerical**Factory Default — **0.0**Changeable During Run — **Yes**

Minimum — 0.0

Maximum — **Max. Freq. (F011)**

Units — Hz

Speed Reach Frequency ToleranceProgram ⇒ Terminal Selection Parameters ⇒ **Reach Settings**

This parameter sets the bandwidth of the **Speed Reach Frequency (F101)** setting.

Direct Access Number — F102Parameter Type — **Numerical**Factory Default — **2.5**Changeable During Run — **Yes**

Minimum — 0.0

Maximum — **Max. Freq. (F011)**

Units — Hz

ST Signal Selection

Program ⇒ Terminal Selection Parameters ⇒ **Input Special Functions**

This parameter is used to set the operation of the **Standby (ST)** control terminal or any terminal configured as the **ST** terminal.

Settings:

- ST-to-CC Required
- ST-to-CC Not Required
- Interlock with F/R Terminal

The setting **ST-to-CC Required** enables the ASD for operation so long as the control terminal **ST** is connected to **CC** via a jumper, contact, or other means.

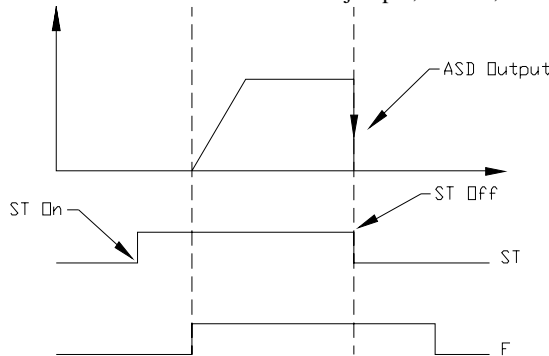

The **ST-to-CC Not Required** setting allows the ASD to operate without the **ST-to-CC** connection. The control terminal **ST** may be configured for other functions.

The **Interlock with F/R Terminal** setting configures the **F (Forward)** and **R (Reverse)** control terminals for the secondary function of **Standby**. Closing a set of contacts to either **F** or **R** will cause the ASD to accelerate the motor to the programmed setpoint of **F** or **R**. Opening the **F** and **R** contact will disable the ASD and the motor will coast to a stop. The control terminal **ST** may be configured for other functions.

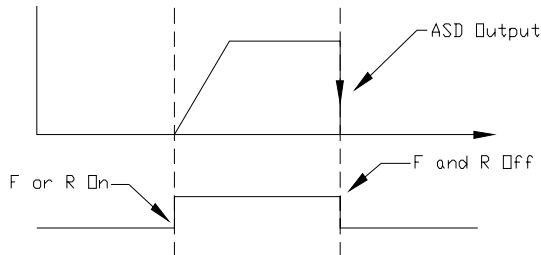

R/F Priority Selection

Program ⇒ Terminal Selection Parameters ⇒ **Input Special Functions**

The **R/F Priority Selection** determines the operation of the ASD if both the **R** and **F** control terminals are activated.

Settings:

- Reverse
- Suspend

The waveforms below depict the motor response for all combinations of the **F** and **R** terminal settings if the **Reverse** option is chosen.

The **Suspend** setting will decelerate the motor to a stop regardless of the rotation direction when both the **F** and **R** control terminals are activated.

Direct Access Number — F103

Parameter Type — **Selection List**

Factory Default — **ST – CC Required**

Changeable During Run — **No**

Direct Access Number — F105

Parameter Type — **Selection List**

Factory Default — **Reverse**

Changeable During Run — **No**

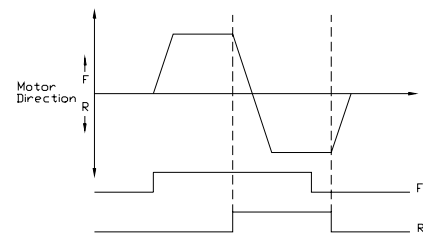

Input Terminal PriorityProgram ⇒ Terminal Selection Parameters ⇒ **Input Special Functions**

This parameter is used to allow the **Jog** and **DC Injection Braking** input signals to control the ASD when received via the **Control Terminal Strip** even though the system is in the **Local** mode.

With this parameter enabled, a **Jog** command or a **DC Injection Braking** command received from the **Control Terminal Strip** will receive priority over commands from the **EOI**.

See **F260** for further information on using the **Jog** function.

See **F250 – F252** for further information on **DC Injection Braking**.

Settings:

Enabled (Box checked)

Disabled

Direct Access Number — F106Parameter Type — **Check Box**Factory Default — **Disabled**Changeable During Run — **No**

Extended Terminal FunctionProgram ⇒ Terminal Selection Parameters ⇒ **Input Special Functions**

The **Extended Terminal Function** is used with the optional **ASD-Multicom** card only. This parameter defines the format of the binary or BCD data when using the option card.

Settings:

None

12-Bit Binary

16-Bit Binary

3-Digit BCD

4-Digit BCD

Reverse 12-Bit Binary

Reverse 16-Bit Binary

Reverse 3-Digit BCD

Reverse 4-Digit BCD

Selections using 16-bit binary or 4-digit BCD will require the configuration of terminals S1-S4 on the **Control Terminal Strip** as binary bits 0 – 3 (**F115 – F118**). The **Frequency Mode #1 Selection (F004)** must be set to **Use Binary/BCD Input**.

For proper scaling of the binary or BCD input, parameters **F228 – F231** must be configured [**BIN Reference Point #1, BIN Reference #1 (frequency), Bin Reference Point #2, and BIN Reference #2 (frequency)**].

Direct Access Number — F107Parameter Type — **Selection List**Factory Default — **None**Changeable During Run — **No**

<p>Motorized Pot Frequency at Power Down</p> <p>Program ⇒ Frequency Setting Parameters ⇒ Motorized Pot Settings</p> <p>When the Frequency Mode #1 Selection (F004) setting is set to Use MOP Function Simulation, this parameter determines the outcome of the Frequency Mode #1 setting at powerdown or stop.</p> <p>Settings:</p> <ul style="list-style-type: none"> Erase Store <p>If Erase is selected, the ASD will not store the frequency setpoint and establishes a setpoint of 0.0 Hz when restarted.</p> <p>If Store is selected, the ASD will maintain the current frequency setpoint in memory while stopped, during fault conditions, or when power is removed. This setpoint will be used as the initial frequency setpoint when the ASD is restarted.</p> <p>A control terminal configured as MOP Frequency Clear will establish a frequency setpoint of 0.0 Hz regardless of the Motorized Pot Frequency at Power Down setting.</p>	<p>Direct Access Number — F108</p> <p>Parameter Type — Selection List</p> <p>Factory Default — Erase</p> <p>Changeable During Run — No</p>
<p>ON Input Terminal Assignment</p> <p>Program ⇒ Terminal Selection Parameters ⇒ Input Terminal Assignment ⇒ ON</p> <p>This parameter selects the functionality of the virtual input terminal ON. As a virtual terminal, the ON control terminal exists only in memory and is considered to always be in its True (or connected to CC) state.</p> <p>It is often practical to assign this terminal to a function that the user desires to be maintained regardless of external conditions or operations.</p> <p>This parameter sets the programmable ON terminal to 1 of the 68 possible functions that are listed in Table 8 on pg. 77.</p>	<p>Direct Access Number — F110</p> <p>Parameter Type — Selection List</p> <p>Factory Default — Unassigned</p> <p>Changeable During Run — No</p>
<p>F Input Terminal Assignment</p> <p>Program ⇒ Terminal Selection Parameters ⇒ Input Terminal Assignment ⇒ F</p> <p>This parameter selects the functionality of the F input terminal.</p> <p>In addition, the input terminal must be specified as Normally Open or Normally Closed.</p> <p>This parameter sets the programmable F terminal to 1 of the 68 possible functions that are listed in Table 8 on pg. 77.</p>	<p>Direct Access Number — F111</p> <p>Parameter Type — Selection List</p> <p>Factory Default — Forward</p> <p>Changeable During Run — No</p>
<p>R Input Terminal Assignment</p> <p>Program ⇒ Terminal Selection Parameters ⇒ Input Terminal Assignment ⇒ R</p> <p>This parameter selects the functionality of the R input terminal.</p> <p>In addition, the input terminal must be specified as Normally Open or Normally Closed.</p> <p>This parameter sets the programmable R terminal to 1 of the 68 possible functions that are listed in Table 8 on pg. 77.</p>	<p>Direct Access Number — F112</p> <p>Parameter Type — Selection List</p> <p>Factory Default — Reverse</p> <p>Changeable During Run — No</p>

<p>ST Input Terminal Assignment</p> <p>Program ⇒ Terminal Selection Parameters ⇒ Input Terminal Assignment ⇒ ST</p> <p>This parameter selects the functionality of the ST input terminal.</p> <p>In addition, the input terminal must be specified as Normally Open or Normally Closed.</p> <p>This parameter sets the programmable ST terminal to 1 of the 68 possible functions that are listed in Table 8 on pg. 77.</p>	<p>Direct Access Number — F113</p> <p>Parameter Type — Selection List</p> <p>Factory Default — Standby</p> <p>Changeable During Run — No</p>
<p>RES Input Terminal Assignment</p> <p>Program ⇒ Terminal Selection Parameters ⇒ Input Terminal Assignment ⇒ RES</p> <p>This parameter selects the functionality of the RES input terminal.</p> <p>In addition, the input terminal must be specified as Normally Open or Normally Closed.</p> <p>This parameter sets the programmable RES terminal to 1 of the 68 possible functions that are listed in Table 8 on pg. 77.</p>	<p>Direct Access Number — F114</p> <p>Parameter Type — Selection List</p> <p>Factory Default — Reset</p> <p>Changeable During Run — No</p>
<p>S1 Input Terminal Assignment</p> <p>Program ⇒ Terminal Selection Parameters ⇒ Input Terminal Assignment ⇒ S1</p> <p>This parameter selects the functionality of the S1 input terminal.</p> <p>In addition, the input terminal must be specified as Normally Open or Normally Closed.</p> <p>This parameter sets the programmable S1 terminal to 1 of the 68 possible functions that are listed in Table 8 on pg. 77.</p>	<p>Direct Access Number — F115</p> <p>Parameter Type — Selection List</p> <p>Factory Default — Preset Speed Cmd #1</p> <p>Changeable During Run — No</p>
<p>S2 Input Terminal Assignment</p> <p>Program ⇒ Terminal Selection Parameters ⇒ Input Terminal Assignment ⇒ S2</p> <p>This parameter selects the functionality of the S2 input terminal.</p> <p>In addition, the input terminal must be specified as Normally Open or Normally Closed.</p> <p>This parameter sets the programmable S2 terminal to 1 of the 68 possible functions that are listed in Table 8 on pg. 77.</p>	<p>Direct Access Number — F116</p> <p>Parameter Type — Selection List</p> <p>Factory Default — Preset Speed Cmd #2</p> <p>Changeable During Run — No</p>
<p>S3 Input Terminal Assignment</p> <p>Program ⇒ Terminal Selection Parameters ⇒ Input Terminal Assignment ⇒ S3</p> <p>This parameter selects the functionality of the S3 input terminal.</p> <p>In addition, the input terminal must be specified as Normally Open or Normally Closed.</p> <p>This parameter sets the programmable S3 terminal to 1 of the 68 possible functions that are listed in Table 8 on pg. 77.</p>	<p>Direct Access Number — F117</p> <p>Parameter Type — Selection List</p> <p>Factory Default — Preset Speed Cmd #3</p> <p>Changeable During Run — No</p>

S4 Input Terminal Assignment

Program ⇒ Terminal Selection Parameters ⇒ Input Terminal Assignment ⇒ **S4**

This parameter selects the functionality of the **S4** input terminal.

In addition, the input terminal must be specified as **Normally Open** or **Normally Closed**.

This parameter sets the programmable **S4** terminal to 1 of the 68 possible functions that are listed in [Table 8 on pg. 77](#).

Direct Access Number — F118

Parameter Type — **Selection List**

Factory Default — **Emergency Off**

Changeable During Run — **No**

S5 Input Terminal Assignment

Program ⇒ Terminal Selection Parameters ⇒ Input Terminal Assignment ⇒ **S5**

This parameter selects the functionality of the **S5** input terminal.

***Note:** The **S5** input terminal may be used without the **ASD-Multicom** option board.*

*Without the **ASD-Multicom** option board the **S5** terminal assignment information will be stored in volatile memory. The terminal assignment information will be lost if the system is powered down or reset.*

In addition, the input terminal must be specified as **Normally Open** or **Normally Closed**.

This parameter sets the programmable **S5** terminal to 1 of the 68 possible functions that are listed in [Table 8 on pg. 77](#).

Direct Access Number — F119

Parameter Type — **Selection List**

Factory Default — **Unassigned**

Changeable During Run — **No**

S6 Input Terminal Assignment

Program ⇒ Terminal Selection Parameters ⇒ Input Terminal Assignment ⇒ **S6**

This parameter selects the functionality of the **S6** input terminal.

***Note:** The **S6** input terminal may be used without the **ASD-Multicom** option board.*

*Without the **ASD-Multicom** option board the **S6** terminal assignment information will be stored in volatile memory. The terminal assignment information will be lost if the system is powered down or reset.*

In addition, the input terminal must be specified as **Normally Open** or **Normally Closed**.

This parameter sets the programmable **S6** terminal to 1 of the 68 possible functions that are listed in [Table 8 on pg. 77](#).

Direct Access Number — F120

Parameter Type — **Selection List**

Factory Default — **Unassigned**

Changeable During Run — **No**

S7 Input Terminal Assignment

Program ⇒ Terminal Selection Parameters ⇒ Input Terminal Assignment ⇒ **S7**

This parameter selects the functionality of the **S7** input terminal.

Note: *The S7 input terminal may be used without the ASD-Multicom option board.*

Without the ASD-Multicom option board the S7 terminal assignment information will be stored in volatile memory. The terminal assignment information will be lost if the system is powered down or reset.

In addition, the input terminal must be specified as **Normally Open** or **Normally Closed**.

This parameter sets the programmable **S7** terminal to 1 of the 68 possible functions that are listed in [Table 8 on pg. 77](#).

Direct Access Number — F121

Parameter Type — **Selection List**

Factory Default — **Unassigned**

Changeable During Run — **No**

Input Terminal 12 Assignment

Program ⇒ Terminal Selection Parameters ⇒ Input Terminal Assignment ⇒ **12**

This parameter selects the functionality of the **#12** input terminal.

Note: *The #12 input terminal may be used without the ASD-Multicom option board.*

Without the ASD-Multicom option board the #12 terminal assignment information will be stored in volatile memory. The terminal assignment information will be lost if the system is powered down or reset.

In addition, the input terminal must be specified as **Normally Open** or **Normally Closed**.

This parameter sets the programmable terminal **#12** to 1 of the 68 possible functions that are listed in [Table 8 on pg. 77](#).

Direct Access Number — F122

Parameter Type — **Selection List**

Factory Default — **Unassigned**

Changeable During Run — **No**

Input Terminal 13 Assignment

Program ⇒ Terminal Selection Parameters ⇒ Input Terminal Assignment ⇒ **13**

This parameter selects the functionality of the **#13** input terminal.

Note: *The #13 input terminal may be used without the ASD-Multicom option board.*

Without the ASD-Multicom option board the #13 terminal assignment information will be stored in volatile memory. The terminal assignment information will be lost if the system is powered down or reset.

In addition, the input terminal must be specified as **Normally Open** or **Normally Closed**.

This parameter sets the programmable terminal **#13** to 1 of the 68 possible functions that are listed in [Table 8 on pg. 77](#).

Direct Access Number — F123

Parameter Type — **Selection List**

Factory Default — **Unassigned**

Changeable During Run — **No**

Input Terminal 14 Assignment

Program ⇒ Terminal Selection Parameters ⇒ Input Terminal Assignment ⇒ **14**

This parameter selects the functionality of the **#14** input terminal.

Note: *The #14 input terminal may be used without the ASD-Multicom option board.*

Without the ASD-Multicom option board the #14 terminal assignment information will be stored in volatile memory. The terminal assignment information will be lost if the system is powered down or reset.

In addition, the input terminal must be specified as **Normally Open** or **Normally Closed**.

This parameter sets the programmable terminal **#14** to 1 of the 68 possible functions that are listed in [Table 8 on pg. 77](#).

Direct Access Number — F124**Parameter Type — Selection List****Factory Default — Unassigned****Changeable During Run — No**

Input Terminal 15 Assignment

Program ⇒ Terminal Selection Parameters ⇒ Input Terminal Assignment ⇒ **15**

This parameter selects the functionality of the **#15** input terminal.

Note: *The #15 input terminal may be used without the ASD-Multicom option board.*

Without the ASD-Multicom option board the #15 terminal assignment information will be stored in volatile memory. The terminal assignment information will be lost if the system is powered down or reset.

In addition, the input terminal must be specified as **Normally Open** or **Normally Closed**.

This parameter sets the programmable terminal **#15** to 1 of the 68 possible functions that are listed in [Table 8 on pg. 77](#).

Direct Access Number — F125**Parameter Type — Selection List****Factory Default — Unassigned****Changeable During Run — No**

Input Terminal 16 Assignment

Program ⇒ Terminal Selection Parameters ⇒ Input Terminal Assignment ⇒ **16**

This parameter selects the functionality of the **#16** input terminal.

Note: *The #16 input terminal may be used without the ASD-Multicom option board.*

Without the ASD-Multicom option board the #16 terminal assignment information will be stored in volatile memory. The terminal assignment information will be lost if the system is powered down or reset.

In addition, the input terminal must be specified as **Normally Open** or **Normally Closed**.

This parameter sets the programmable terminal **#16** to 1 of the 68 possible functions that are listed in [Table 8 on pg. 77](#).

Direct Access Number — F126**Parameter Type — Selection List****Factory Default — Unassigned****Changeable During Run — No**

Table 8. Discrete Input Terminal Assignment Selections and Descriptions.

0 — Unassigned — No operation.
1 — F — Enables Forward operation commands.
2 — R — Enables Reverse operation commands.
3 — ST — Enables the Forward and Reverse operation commands (maybe disabled at F103).
4 — RES — Resets the device and any incurred faults.
5 — S1 — Preset Speed Command 1 is used as the LSB of the 4-bit nibble that is used to select a Preset Speed .
6 — S2 — Preset Speed Command 2 is used as the second bit of the 4-bit nibble that is used to select a Preset Speed .
7 — S3 — Preset Speed Command 3 is used as the third bit of the 4-bit nibble that is used to select a Preset Speed .
8 — S4 — Preset Speed Command 4 is used as the MSB of the 4-bit nibble that is used to select a Preset Speed .
9 — Jog — Jog is the term used to describe turning on the motor for small increments of time and is used when precise positioning of motor-driven equipment is required. This terminal activates a Jog for the duration of activation. The Jog settings may be configured at F260 and F261 .
10 — Emergency Off — Terminates the output signal from the drive and may apply a brake. The braking method may be selected at F603 .
11 — DC Braking — The drive outputs a DC current that is injected into the windings of the motor to quickly brake the motor.
12 — Accel/Decel 1, 2 Switching — Acceleration and Deceleration control may be switched between the #1 profile to the #2 profile if using a multiple-accel/decel profile configuration.
13 — Accel/Decel 3, 4 Switching — Acceleration and Deceleration control may be switched between the #3 profile to the #4 profile if using a multiple-accel/decel profile configuration.
14 — Motor 1, 2 Switching — Motor control may be switched between the Motor #1 profile to the Motor #2 profile if using a multiple-motor profile configuration.
15 — Motor 3, 4 Switching — Motor control may be switched between the Motor #3 profile to the Motor #4 profile if using a multiple-motor profile configuration.
16 — Torque Limit 1, 2 Switching — Torque control may be switched between the Torque Limit #1 profile to the Torque Limit #2 profile if using a multiple-profile configuration.
17 — Torque Limit 3, 4 Switching — Torque control may be switched between the Torque Limit #3 profile to the Torque Limit #4 profile if using a multiple-profile configuration.
18 — PID Control Off — Connecting this terminal to CC turns off PID control.
19 — Pattern #1 — Connecting this terminal to CC initiates the Pattern #1 Pattern Run .
20 — Pattern #2 — Connecting this terminal to CC initiates the Pattern #2 Pattern Run .
21 — Pattern #3 — Connecting this terminal to CC initiates the Pattern #3 Pattern Run .
22 — Pattern #4 — Connecting this terminal to CC initiates the Pattern #4 Pattern Run .
23 — Pattern Continue — Continues with the last Pattern Run from its stopping point when connected to CC .
24 — Pattern Trigger — This function is used to sequentially initiate each Preset Speed of a Pattern Run with each connection to CC .
25 — Forced Jog Forward — This setting initiates a Forced Forward Jog when connected to CC . The Forced Forward Jog command provides a forward-run signal so long as this terminal is connected to CC (the status of the F and R terminals is ignored). Use F260 to set the Jog Frequency and use F261 to select the Jog Stop Method .
26 — Forced Jog Reverse — This setting initiates a Forced Reverse Jog when connected to CC . The Forced Reverse Jog command provides a reverse-run signal so long as this terminal is connected to CC (the status of the F and R terminals is ignored). Use F260 to set the Jog Frequency and use F261 to select the Jog Stop Method .
27 — Binary Bit 0 — Bit 0 – 7 may be set up as a speed/torque control register. Speed/torque settings may be applied to this group of terminals in binary form. The required number of input terminals should be set to the respective binary bit settings (0 – MSB). The Frequency Mode setting must be set to Use Binary/BCD input . The gain and bias of the binary input may be set from the following path: Program ⇒ Frequency Setting Parameters ⇒ Speed Reference Setpoints ⇒ BIN (see F228).

Table 8. (Continued)Discrete Input Terminal Assignment Selections and Descriptions.

28 — Binary Bit 1 — See selection 27 above.
29 — Binary Bit 2 — See selection 27 above.
30 — Binary Bit 3 — See selection 27 above.
31 — Binary Bit 4 — See selection 27 above.
32 — Binary Bit 5 — See selection 27 above.
33 — Binary Bit 6 — See selection 27 above.
34 — Binary Bit 7 — See selection 27 above.
35 — Forced Stop — Activating this terminal terminates the Run command regardless of the Command Mode setting and initiates the programmed stopping method.
36 — Stop Key Emulation — Activating this terminal terminates the Run command being received from communications devices and initiates the programmed stopping method.
37 — Reserved — No operation.
38 — Reserved — No operation.
39 — Reserved — No operation.
40 — Reserved — No operation.
41 — Reserved — No operation.
42 — Reserved — No operation.
43 — Binary Data Write — This terminal serves two functions: <ul style="list-style-type: none"> 1) While operating in the Use Binary/BCD input mode, each momentary connection of this terminal to CC transfers the speed/torque Binary Bit (0 – MSB) settings to the motor. 2) The Motorized Pot frequency command will be saved during power down or reset by setting F108 to Store and setting an input terminal to 43:binary Data Write. If the drive is running and the Binary Data Write terminal is active when an event occurs (Fault, Power off), the Motorized Pot frequency command will be restored upon power-up or reset.
44 — Motorized Pot Up (MOP) — Momentarily connecting this terminal to CC causes an increase in motor speed for the duration of the connection until the Upper Limit is reached. The Frequency Mode setting must be set to Motorized Pot. Simulation . The MOP acceleration rate is determined by the F500 setting.
45 — Motorized Pot Down (MOP) — Momentarily connecting this terminal to CC causes a decrease in motor speed for the duration of the connection until the Lower Limit is reached. The Frequency Mode setting must be set to Motorized Pot. Simulation . The MOP deceleration rate is determined by the F501 setting.
46 — Motorized Pot Clear — Connecting this terminal to CC clears the last Motorized Pot frequency settings (see F108 for further information on this setting).
47 — Momentary Push Run — When connected to CC this terminal setting starts the motor.
48 — Momentary Push Stop — When connected to CC this terminal setting stops the motor.
49 — Forward/Reverse — This setting operates in conjunction with another terminal being set to the Run/Stop (50) function. When configured to Run (Run/Stop to CC) , the make or break of this connection to CC changes the direction of the motor.
50 — Run/Stop — This terminal enables the motor to run when connected to CC and disables the motor when the connection is broken.
51 — Line Power Bypass — This function operates in conjunction with the Line Power Switching frequency setting (F355). An enabled check box at Program ⇒ Terminal Selection Parameters ⇒ Line Power Switching (At) and this input terminal setting enables this function. Once configured (including this terminal connection to CC), the frequency setting of Line Power Switching (Hz) establishes the speed at which the drive terminates its output and routes commercial power to the motor.

Table 8. (Continued)Discrete Input Terminal Assignment Selections and Descriptions.

52 — Frequency Priority — Connecting this terminal to CC allows for the frequency control to be switched from the frequency command source selected as Frequency Mode #1 to Frequency Mode #2 . This function is enabled by setting the Reference Priority Selection to Frequency Source Priority Switching and is located at Program ⇒ Fundamental Parameters ⇒ Standard Mode Selection ⇒ Reference Priority Selection ⇒ Frequency Source Priority Switching .
53 — VI/II Terminal Priority — Connecting this terminal to CC assigns command control to the VI/II Terminal and overrides all other Control Terminal Strip input so long as the Command Mode is set to Use Control Terminal Strip .
54 — Command Control Terminal Strip Priority — Connecting this terminal to CC overrides the FMOD setting and assigns speed control to the Control Terminal Strip .
55 — Parameter Editing Enabling (LED) — The LED Keypad system is unavailable at the time of this release.
56 — Control Switch (torque, position) — This function allows for a system change from speed to torque or position as a function of the V/f setting when connected to CC .
57 — Deviation Counter Clear — This function clears the Deviation Counter while operating in the Position Control mode.
58 — Position Control Forward Limit LS — Connecting this terminal to CC will immediately stop the drive and hold its position. If the connection remains the drive will time out and trip. This function is normally used for over-travel conditions.
59 — Position Control Reverse Limit LS — Connecting this terminal to CC will immediately stop the drive and hold its position. If the connection remains the drive will time out and trip. This function is normally used for over-travel conditions.
60 — Light-Load High-Speed Operation Enable — Activating this terminal sets the lower limit of an output frequency range in which the Light-load/High-speed function may be used (see F330). The Light-load/High-speed function accelerates the output frequency of the ASD to the speed setting established in F341 for the duration of the activation.
61 — Snap Stop Control Enable — TBD.
62 — Pre-excite Motor — Connecting this terminal to CC applies an excitation current to the motor (holds shaft stationary) for the duration of the connection.
63 — System Consistent Sequence (BC: braking command) — TBD.
64 — System Consistent Sequence (B: braking release) — Connecting this input terminal to CC initiates the brake release command. This setting requires that another discrete input terminal be set to 65 [System Consistent Sequence (BA: braking answer)] to complete the brake release command and to convey the status of the braking system to the user or to a dependent subsystem. Once the braking release function is initiated, the Trouble Internal Timer begins to count down (Trouble Internal Timer value is set at F630). Should the count-down timer expire before the brake releases or before the Braking Answer is returned, fault E-11 will occur. Otherwise, the brake releases the motor and normal motor operations resume. The Braking Release function is primarily used at startup; but, may be used when the brake is applied while the motor is running.
65 — System Consistent Sequence (BA: braking answer) — This setting is required when the Braking Release (64) function is used. The function of this input terminal is to receive the returned status of the braking system. The returned status is either Released or Not Released . If Released is returned within the time setting of F630 , normal system function resumes. If Not Released is returned or if the F630 time setting times out before either signal is returned, then fault E-11 occurs. The returned signal may also be used to notify the user or control a dependent subsystem.
66 — System Consistent Sequence (BT: braking test) — TBD.
67 — Output Frequency Hold — TBD.

OUT1 Output Terminal Assignment

Program ⇒ Terminal Selection Parameters ⇒ Output Terminal Assignment ⇒ **OUT1**

This parameter sets the functionality of the **OUT1 (A & C)** output terminals to 1 of the 62 possible functions that are listed in [Table 9 on pg. 82](#).

The on and off delay times of the **OUT1** terminals may be adjusted to provide more response time to the device that is connected to the output terminals.

In addition, the output terminals must be specified as **Normally Open** or **Normally Closed**.

Direct Access Number — F130

Parameter Type — Selection List

Factory Default — Low

Changeable During Run — No

OUT2 Output Terminal Assignment

Program ⇒ Terminal Selection Parameters ⇒ Output Terminal Assignment ⇒ **OUT2**

This parameter sets the functionality of the **OUT2 (A & C)** output terminals to 1 of the 62 possible functions that are listed in [Table 9 on pg. 82](#).

The on and off delay times of the **OUT2** terminals may be adjusted to provide more response time to the device that is connected to the output terminals.

In addition, the output terminals must be specified as **Normally Open** or **Normally Closed**.

Direct Access Number — F131

Parameter Type — Selection List

Factory Default — RCH (Acc/Dec Complete)

Changeable During Run — No

FL Output Terminal Assignment

Program ⇒ Terminal Selection Parameters ⇒ Output Terminal Assignment ⇒ **FL**

This parameter sets the functionality of the **FL** output terminals to 1 of the 62 possible functions that are listed in [Table 9 on pg. 82](#).

The on and off delay times of the **FL** terminals may be adjusted to provide more response time to the device that is connected to the output terminals.

In addition, the output terminals must be specified as **Normally Open** or **Normally Closed**.

Direct Access Number — F132

Parameter Type — Selection List

Factory Default — Fault (All)

Changeable During Run — No

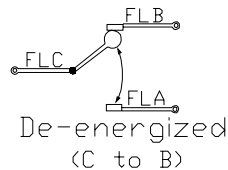
**Output #4 Terminal Assignment**

Program ⇒ Terminal Selection Parameters ⇒ Output Terminal Assignment ⇒ **4**

This parameter sets the functionality of the **OUT4** terminals to 1 of the 62 possible functions that are listed in [Table 9 on pg. 82](#).

The on and off delay times of the **OUT4** terminals may be adjusted to provide more response time to the device that is connected to the output terminals.

In addition, the output terminals must be specified as **Normally Open** or **Normally Closed**.

Direct Access Number — F133

Parameter Type — Selection List

Factory Default — LL

Changeable During Run — No

<p>OUT5 Terminal Assignment</p> <p>Program ⇒ Terminal Selection Parameters ⇒ Output Terminal Assignment ⇒ 5</p> <p>This parameter sets the functionality of the OUT5 terminals to 1 of the 62 possible functions that are listed in Table 9 on pg. 82.</p> <p>The on and off delay times of the OUT5 terminals may be adjusted to provide more response time to the device that is connected to the output terminals.</p> <p>In addition, the output terminals must be specified as Normally Open or Normally Closed.</p>	<p>Direct Access Number — F134</p> <p>Parameter Type — Selection List</p> <p>Factory Default — UL</p> <p>Changeable During Run — No</p>
<p>OUT6 Terminal Assignment</p> <p>Program ⇒ Terminal Selection Parameters ⇒ Output Terminal Assignment ⇒ 6</p> <p>This parameter sets the functionality of the OUT6 terminals to 1 of the 62 possible functions that are listed in Table 9 on pg. 82.</p> <p>The on and off delay times of the OUT6 terminals may be adjusted to provide more response time to the device that is connected to the output terminals.</p> <p>In addition, the output terminals must be specified as Normally Open or Normally Closed.</p>	<p>Direct Access Number — F135</p> <p>Parameter Type — Selection List</p> <p>Factory Default — RCH (Specified Speed)</p> <p>Changeable During Run — No</p>
<p>OUT7 Terminal Assignment</p> <p>Program ⇒ Terminal Selection Parameters ⇒ Output Terminal Assignment ⇒ 7</p> <p>This parameter sets the functionality of the OUT7 terminals to 1 of the 62 possible functions that are listed in Table 9 on pg. 82.</p> <p>The on and off delay times of the OUT7 terminals may be adjusted to provide more response time to the device that is connected to the output terminals.</p> <p>In addition, the output terminals must be specified as Normally Open or Normally Closed.</p>	<p>Direct Access Number — F136</p> <p>Parameter Type — Selection List</p> <p>Factory Default — Overcurrent Prealarm</p> <p>Changeable During Run — No</p>
<p>F Input Terminal Delay</p> <p>Program ⇒ Terminal Selection Parameters ⇒ Input Terminal Delays ⇒ F</p> <p>This parameter delays the response of the ASD to any change in the F terminal input by the programmed value.</p>  <p>The delay may be increased to provide additional electrical noise immunity or to prevent the ASD from responding to contact bounce or chatter.</p>	<p>Direct Access Number — F140</p> <p>Parameter Type — Numerical</p> <p>Factory Default — 8.0</p> <p>Changeable During Run — No</p> <p>Minimum — 2.0</p> <p>Maximum — 200.0</p> <p>Units — mS</p>

Table 9. Discrete Output Terminal Assignment Selections.

	Function		Function
0	Lower Limit (LL)	31	Ready for Operation (including ST and RUN)
1	Upper Limit (UL)	32	Ready for Operation
2	Low (speed setting of F100)	33	POFF Alarm (poor control power supply)
3	RCH (Acc/Dec completion)	34	System Consistent Sequence (BR: brake release)
4	RCH (speed specified at F101)	35	In Alarm Status
5	Fault FL (all)	36	Forward Speed Limit (torque control)
6	Fault FL (except EF or OCL)	37	Reverse Speed Limit (torque control)
7	Overcurrent Pre-alarm	38	ASD Healthy Output
8	ASD Overload Pre-alarm	39	Abnormal Communication Alarm 2 (internal cause)
9	Motor Pre-alarm	40	Error Code Output 1 (6-bit error output)
10	Overheat Pre-alarm	41	Error Code Output 2 (6-bit error output)
11	Overvoltage Pre-alarm	42	Error Code Output 3 (6-bit error output)
12	DC Voltage Low Alarm	43	Error Code Output 4 (6-bit error output)
13	Low-current Alarm	44	Error Code Output 5 (6-bit error output)
14	Overtorque Alarm	45	Error Code Output 6 (6-bit error output)
15	Braking Resistor Overload Pre-alarm	46	Designated Data Output 1 (7-bit transmission output)
16	In Emergency Off	47	Designated Data Output 2 (7-bit transmission output)
17	Retrying	48	Designated Data Output 3 (7-bit transmission output)
18	Pattern Operation Switching Out	49	Designated Data Output 4 (7-bit transmission output)
19	PID Deviation Limit	50	Designated Data Output 5 (7-bit transmission output)
20	Start/Stop	51	Designated Data Output 6 (7-bit transmission output)
21	Serious Fault (OCA, OCL, EF, Lost Phase, Short Circuit, or Abnormal Output)	52	Designated Data Output 7 (7-bit transmission output)
22	Light Fault (OL, OC1, 2, 3, OP)	53	Light Load Detection Signal
23	Bypass Output #1	54	Heavy Load Detection Signal
24	Bypass Output #2	55	Positive Torque Limit
25	Fan On/Off	56	Negative Torque Limit
26	Jogging	57	External Rush Suppression Relay Output
27	Control Terminal Strip Operation Command Mode	58	Over Travel
28	Total-operation-hours Alarm	59	Positioning Completion
29	Abnormal Communication Alarm (external cause)	60	Earth Fault Alarm
30	Forward/Reverse Operation	61	Low Output Disable Alarm

<p>R Input Terminal Delay</p> <p>Program ⇒ Terminal Selection Parameters ⇒ Input Terminal Delays ⇒ R</p> <p>This parameter delays the response of the drive to any change in the R terminal input by the programmed value (see waveforms at F140).</p> <p>The delay may be increased to provide additional electrical noise immunity or to prevent the ASD from responding to contact bounce or chatter.</p>	<p>Direct Access Number — F141</p> <p>Parameter Type — Numerical</p> <p>Factory Default — 8.0</p> <p>Changeable During Run — No</p> <p>Minimum — 2.0</p> <p>Maximum — 200.0</p> <p>Units — mS</p>
<p>ST Input Terminal Delay</p> <p>Program ⇒ Terminal Selection Parameters ⇒ Input Terminal Delays ⇒ ST</p> <p>This parameter delays the response of the drive to any change in the ST terminal input by the programmed value (see waveforms at F140).</p> <p>The delay may be increased to provide additional electrical noise immunity or to prevent the ASD from responding to contact bounce or chatter.</p>	<p>Direct Access Number — F142</p> <p>Parameter Type — Numerical</p> <p>Factory Default — 8.0</p> <p>Changeable During Run — No</p> <p>Minimum — 2.0</p> <p>Maximum — 200.0</p> <p>Units — mS</p>
<p>RES Input Terminal Delay</p> <p>Program ⇒ Terminal Selection Parameters ⇒ Input Terminal Delays ⇒ RES</p> <p>This parameter delays the response of the drive to any change in the RES terminal input by the programmed value (see waveforms at F140).</p> <p>The delay may be increased to provide additional electrical noise immunity or to prevent the ASD from responding to contact bounce or chatter.</p>	<p>Direct Access Number — F143</p> <p>Parameter Type — Numerical</p> <p>Factory Default — 8.0</p> <p>Changeable During Run — No</p> <p>Minimum — 2.0</p> <p>Maximum — 200.0</p> <p>Units — mS</p>
<p>S1 – S4 Input Terminal Delay</p> <p>Program ⇒ Terminal Selection Parameters ⇒ Input Terminal Delays ⇒ S1 – S4</p> <p>This parameter delays the response of the drive to any change in the S1 – S4 terminal input by the programmed value (see waveforms at F140).</p> <p>The delay may be increased to provide additional electrical noise immunity or to prevent the ASD from responding to contact bounce or chatter.</p>	<p>Direct Access Number — F144</p> <p>Parameter Type — Numerical</p> <p>Factory Default — 8.0</p> <p>Changeable During Run — No</p> <p>Minimum — 2.0</p> <p>Maximum — 200.0</p> <p>Units — mS</p>
<p>S5 – S16 Input Terminal Delay</p> <p>Program ⇒ Terminal Selection Parameters ⇒ Input Terminal Delays ⇒ S5 – S16</p> <p>This parameter delays the response of the drive to any change in the S5 – S16 terminal input by the programmed value (see waveforms at F140).</p> <p>The delay may be increased to provide additional electrical noise immunity or to prevent the ASD from responding to contact bounce or chatter.</p>	<p>Direct Access Number — F145</p> <p>Parameter Type — Numerical</p> <p>Factory Default — 8.0</p> <p>Changeable During Run — No</p> <p>Minimum — 2.0</p> <p>Maximum — 200.0</p> <p>Units — mS</p>

OUT1 On Delay

Program ⇒ Terminal Selection Parameters ⇒ Output Terminal Delays ⇒ **OUT1**

Once the condition is met to close the **OUT1 (A & C)** output terminals, this parameter delays the closing of the terminals by the programmed value.

For example, if the **OUT1** function is programmed as **Overtorque Alarm**, **OUT1** will close 2.0 mS (the default value for **OUT1 On Delay**) after the overtorque condition occurs.

The delay may be increased to prevent relay chatter.

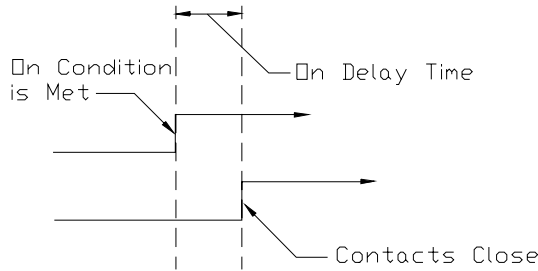

Direct Access Number — F150

Parameter Type — **Numerical**

Factory Default — **2.0**

Changeable During Run — **No**

Minimum — 2.0

Maximum — 200.0

Units — mS

OUT2 On Delay

Program ⇒ Terminal Selection Parameters ⇒ Output Terminal Delays ⇒ **OUT2**

This parameter delays the closing of the **OUT2 (A & C)** output terminals by the programmed value (see waveforms at **F150**).

The delay may be increased to prevent relay chatter.

Direct Access Number — F151

Parameter Type — **Numerical**

Factory Default — **2.0**

Changeable During Run — **No**

Minimum — 2.0

Maximum — 200.0

Units — mS

FL On Delay

Program ⇒ Terminal Selection Parameters ⇒ Output Terminal Delays ⇒ **FL**

This parameter delays the closing of the **FL** output terminals by the programmed value (see waveforms at **F150**).

The delay may be increased to prevent relay chatter.

Direct Access Number — F152

Parameter Type — **Numerical**

Factory Default — **2.0**

Changeable During Run — **No**

Minimum — 2.0

Maximum — 200.0

Units — mS

OUT4 On Delay

Program ⇒ Terminal Selection Parameters ⇒ Output Terminal Delays ⇒ **OUT4**

This parameter delays the closing of the **OUT4** output terminals by the programmed value (see waveforms at **F150**).

The delay may be increased to prevent relay chatter.

Direct Access Number — F153

Parameter Type — **Numerical**

Factory Default — **2.0**

Changeable During Run — **No**

Minimum — 2.0

Maximum — 200.0

Units — mS

OUT5 On Delay

Program ⇒ Terminal Selection Parameters ⇒ Output Terminal Delays ⇒ **OUT5**

This parameter delays the closing of the **OUT5** output terminals by the programmed value (see waveforms at **F150**).

The delay may be increased to prevent relay chatter.

Direct Access Number — F154

Parameter Type — **Numerical**

Factory Default — **2.0**

Changeable During Run — **No**

Minimum — 2.0

Maximum — 200.0

Units — mS

OUT6 On Delay

Program ⇒ Terminal Selection Parameters ⇒ Output Terminal Delays ⇒ **OUT6**

This parameter delays the closing of the **OUT6** output terminals by the programmed value (see waveforms at **F150**).

The delay may be increased to prevent relay chatter.

Direct Access Number — F155

Parameter Type — **Numerical**

Factory Default — **2.0**

Changeable During Run — **No**

Minimum — 2.0

Maximum — 200.0

Units — mS

OUT7 On Delay

Program ⇒ Terminal Selection Parameters ⇒ Output Terminal Delays ⇒ **OUT7**

This parameter delays the closing of the **OUT7** output terminals by the programmed value (see waveforms at **F150**).

The delay may be increased to prevent relay chatter.

Direct Access Number — F156

Parameter Type — **Numerical**

Factory Default — **2.0**

Changeable During Run — **No**

Minimum — 2.0

Maximum — 200.0

Units — mS

OUT1 Off Delay

Program ⇒ Terminal Selection Parameters ⇒ Output Terminal Delays ⇒ **OUT1**

This parameter delays the opening of the **OUT1 (A & C)** output terminals by the programmed value.

The delay may be increased to allow the devices that are connected to **OUT1** to respond.

Direct Access Number — F160

Parameter Type — **Numerical**

Factory Default — **2.0**

Changeable During Run — **No**

Minimum — 2.0

Maximum — 200.0

Units — mS

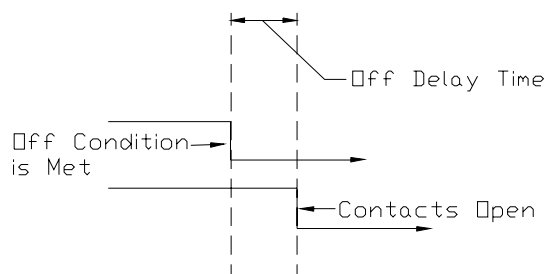

OUT2 Off Delay

Program ⇒ Terminal Selection Parameters ⇒ Output Terminal Delays ⇒ **OUT2**

This parameter delays the opening of the **OUT2 (A & C)** output terminals by the programmed value (see waveforms at **F160**).

The delay may be increased to allow the devices that are connected to **OUT2** to respond.

Direct Access Number — F161

Parameter Type — **Numerical**

Factory Default — **2.0**

Changeable During Run — **No**

Minimum — 2.0

Maximum — 200.0

Units — mS

FL Off Delay

Program ⇒ Terminal Selection Parameters ⇒ Output Terminal Delays ⇒ **FL**

This parameter delays the opening of the **FL** output terminals by the programmed value (see waveforms at **F160**).

The delay may be increased to allow the devices that are connected to **FL** to respond.

Direct Access Number — F162

Parameter Type — **Numerical**

Factory Default — **2.0**

Changeable During Run — **No**

Minimum — 2.0

Maximum — 200.0

Units — mS

<p>OUT4 Off Delay</p> <p>Program ⇒ Terminal Selection Parameters ⇒ Output Terminal Delays ⇒ OUT4</p> <p>This parameter delays the opening of the OUT4 output terminals by the programmed value (see waveforms at F160).</p> <p>The delay may be increased to allow the devices that are connected to OUT4 to respond.</p>	<p>Direct Access Number — F163</p> <p>Parameter Type — Numerical</p> <p>Factory Default — 2.0</p> <p>Changeable During Run — No</p> <p>Minimum — 2.0</p> <p>Maximum — 200.0</p> <p>Units — mS</p>
<p>OUT5 Off Delay</p> <p>Program ⇒ Terminal Selection Parameters ⇒ Output Terminal Delays ⇒ OUT5</p> <p>This parameter delays the opening of the OUT5 output terminals by the programmed value (see waveforms at F160).</p> <p>The delay may be increased to allow the devices that are connected to OUT5 to respond.</p>	<p>Direct Access Number — F164</p> <p>Parameter Type — Numerical</p> <p>Factory Default — 2.0</p> <p>Changeable During Run — No</p> <p>Minimum — 2.0</p> <p>Maximum — 200.0</p> <p>Units — mS</p>
<p>OUT6 Off Delay</p> <p>Program ⇒ Terminal Selection Parameters ⇒ Output Terminal Delays ⇒ OUT6</p> <p>This parameter delays the opening of the OUT6 output terminals by the programmed value (see waveforms at F160).</p> <p>The delay may be increased to allow the devices that are connected to OUT6 to respond.</p>	<p>Direct Access Number — F165</p> <p>Parameter Type — Numerical</p> <p>Factory Default — 2.0</p> <p>Changeable During Run — No</p> <p>Minimum — 2.0</p> <p>Maximum — 200.0</p> <p>Units — mS</p>
<p>OUT7 Off Delay</p> <p>Program ⇒ Terminal Selection Parameters ⇒ Output Terminal Delays ⇒ OUT7</p> <p>This parameter delays the opening of the OUT7 output terminals by the programmed value (see waveforms at F160).</p> <p>The delay may be increased to allow the devices that are connected to OUT7 to respond.</p>	<p>Direct Access Number — F166</p> <p>Parameter Type — Numerical</p> <p>Factory Default — 2.0</p> <p>Changeable During Run — No</p> <p>Minimum — 2.0</p> <p>Maximum — 200.0</p> <p>Units — mS</p>
<p>Motor #2 Base Frequency</p> <p>Program ⇒ Motor Parameters ⇒ Motor Set #2</p> <p>The Motor #2 Base Frequency setting is the frequency at which the output voltage of the ASD reaches its maximum setting. The #2 Maximum Output Voltage is set at F171.</p> <p>This parameter is used only when the parameters for motor set #2 are configured and selected. Motor set #2 may be selected by a properly configured input terminal.</p> <p>For proper motor operation, the Base Frequency should be set for the name-plated frequency of the motor.</p>	<p>Direct Access Number — F170</p> <p>Parameter Type — Numerical</p> <p>Factory Default — 60.0</p> <p>Changeable During Run — Yes</p> <p>Minimum — 25.0</p> <p>Maximum — 299.0</p> <p>Units — Hz</p>

Motor #2 Max Output Voltage

Program ⇒ Motor Parameters ⇒ **Motor Set #2**

The **Motor #2 Maximum Output Voltage** is the **Motor #2** output voltage at the **Base Frequency (F170)**. Regardless of the programmed value, the output voltage cannot be higher than the input voltage.

The actual output voltage will be influenced by the input voltage of the ASD and the **Supply Voltage Compensation** setting (**F307**).

This parameter is used only when the parameters for motor set #2 are configured and selected. Motor set #2 may be selected by a properly configured input terminal.

Direct Access Number — F171

Parameter Type — **Numerical**

Factory Default — **(ASD-dependent)**

Changeable During Run — **Yes**

Minimum — 0.0

Maximum — 600.0

Units — Volts

Motor #2 Torque Boost

Program ⇒ Motor Parameters ⇒ **Motor Set #2**

The **Motor #2 Torque Boost** function is used to increase the low frequency torque for high inertia loads by increasing the output voltage at frequencies below ½ of the **#2 Base Frequency** setting (**F170**).

See parameter **F016 (Motor #1 Torque Boost)** for an explanation of torque boost.

This parameter is used only when the parameters for motor set #2 are configured and selected. Motor set #2 may be selected by a properly configured input terminal.

Direct Access Number — F172

Parameter Type — **Numerical**

Factory Default — **(ASD-dependent)**

Changeable During Run — **Yes**

Minimum — 0.0

Maximum — 30.0

Units — %

Electronic Thermal Protection #2

Program ⇒ Motor Parameters ⇒ **Motor Set #2**

The **Motor #2 Electronic Thermal Protection** parameter specifies the motor overload current level for motor set #2. This value is entered as either a percentage of the full load rating of the ASD or as the FLA of the motor.

The unit of measurement for this parameter may be set to **Amps (V/A)** or it may be set as a percentage of the ASD rating. The name-plated FLA of the motor may be entered directly when **Amps** is selected as the unit of measurement (see **F701** to change the display unit).

Electronic Thermal Protection settings (#1 – #4) will be displayed in **Amps** if the **EOI** display units are set to **V/A** rather than **%**.

Direct Access Number — F173

Parameter Type — **Numerical**

Factory Default — **100.0**

Changeable During Run — **Yes**

Minimum — 10.0

Maximum — 100.0

Units — %

Motor #3 Base Frequency

Program ⇒ Motor Parameters ⇒ **Motor Set #3**

The **Motor #3 Base Frequency** setting is the frequency at which the output voltage of the ASD reaches its maximum setting. The **Maximum Output Voltage** is set at **F175**.

This parameter is used only when the parameters for motor set #3 are configured and selected. Motor set #3 may be selected by a properly configured input terminal.

For proper motor operation, the **Base Frequency** should be set for the name-plated frequency of the motor.

Direct Access Number — F174

Parameter Type — **Numerical**

Factory Default — **60.0**

Changeable During Run — **Yes**

Minimum — 25.0

Maximum — 299.0

Units — Hz

<p>Motor #3 Max Output Voltage</p> <p>Program ⇒ Motor Parameters ⇒ Motor Set #3</p> <p>The Motor #3 Maximum Output Voltage is the Motor #3 output voltage at the Base Frequency (F174). Regardless of the programmed value, the output voltage cannot be higher than the input voltage.</p> <p>The actual output voltage will be influenced by the input voltage of the ASD and the Supply Voltage Compensation setting (F307).</p> <p>This parameter is used only when the parameters for motor set #3 are configured and selected. Motor set #3 may be selected by a properly configured input terminal.</p>	<p>Direct Access Number — F175</p> <p>Parameter Type — Numerical</p> <p>Factory Default — (ASD-dependent)</p> <p>Changeable During Run — Yes</p> <p>Minimum — 0.0</p> <p>Maximum — 600.0</p> <p>Units — Volts</p>
<p>Motor #3 Torque Boost</p> <p>Program ⇒ Motor Parameters ⇒ Motor Set #3</p> <p>The Motor #3 Torque Boost function is used to increase the low frequency torque for high inertia loads by increasing the output voltage at frequencies below ½ of the #3 Base Frequency setting (F174).</p> <p>See parameter F016 (Motor #1 Torque Boost) for an explanation of torque boost.</p> <p>This parameter is used only when the parameters for motor set #3 are configured and selected. Motor set #3 may be selected by a properly configured input terminal.</p>	<p>Direct Access Number — F176</p> <p>Parameter Type — Numerical</p> <p>Factory Default — (ASD-dependent)</p> <p>Changeable During Run — Yes</p> <p>Minimum — 0.0</p> <p>Maximum — 30.0</p> <p>Units — %</p>
<p>Electronic Thermal Protection #3</p> <p>Program ⇒ Motor Parameters ⇒ Motor Set #3</p> <p>The Motor #3 Electronic Thermal Protection parameter specifies the motor overload current level for motor set #3. This value is entered as either a percentage of the full load rating of the ASD or as the FLA of the motor.</p> <p>The unit of measurement for this parameter may be set to Amps (V/A) or it may be set as a percentage of the ASD rating. The name-plated FLA of the motor may be entered directly when Amps is selected as the unit of measurement (see F701 to change the display unit).</p> <p>Electronic Thermal Protection settings (#1 – #4) will be displayed in Amps if the EOI display units are set to V/A rather than %.</p>	<p>Direct Access Number — F177</p> <p>Parameter Type — Numerical</p> <p>Factory Default — 100.0</p> <p>Changeable During Run — Yes</p> <p>Minimum — 10.0</p> <p>Maximum — 100.0</p> <p>Units — %</p>
<p>Motor #4 Base Frequency</p> <p>Program ⇒ Motor Parameters ⇒ Motor Set #4</p> <p>The Motor #4 Base Frequency setting is the frequency at which the output voltage of the ASD reaches its maximum setting. The Maximum Output Voltage is set at F179.</p> <p>This parameter is used only when the parameters for motor set #4 are configured and selected. Motor set #4 may be selected by a properly configured input terminal.</p> <p>For proper motor operation, the Base Frequency should be set for the name-plated frequency of the motor.</p>	<p>Direct Access Number — F178</p> <p>Parameter Type — Numerical</p> <p>Factory Default — 60.0</p> <p>Changeable During Run — Yes</p> <p>Minimum — 25.0</p> <p>Maximum — 299.0</p> <p>Units — Hz</p>

Motor #4 Max Output Voltage

Program ⇒ Motor Parameters ⇒ **Motor Set #4**

The **Motor #3 Maximum Output Voltage** is the **Motor #4** output voltage at the **Base Frequency (F178)**. Regardless of the programmed value, the output voltage cannot be higher than the input voltage.

The actual output voltage will be influenced by the input voltage of the ASD and the **Supply Voltage Compensation** setting (**F307**).

This parameter is used only when the parameters for motor set #4 are configured and selected. Motor set #4 may be selected by a properly configured input terminal.

Direct Access Number — F179

Parameter Type — **Numerical**

Factory Default — **(ASD-dependent)**

Changeable During Run — **Yes**

Minimum — 0.0

Maximum — 600.0

Units — Volts

Motor #4 Torque Boost

Program ⇒ Motor Parameters ⇒ **Motor Set #4**

The **Motor #4 Torque Boost** function is used to increase the low frequency torque for high inertia loads by increasing the output voltage at frequencies below ½ of the **#4 Base Frequency** setting (**F178**).

See parameter **F016 (Motor #1 Torque Boost)** for an explanation of torque boost.

This parameter is used only when the parameters for motor set #4 are configured and selected. Motor set #4 may be selected by a properly configured input terminal.

Direct Access Number — F180

Parameter Type — **Numerical**

Factory Default — **(ASD-dependent)**

Changeable During Run — **Yes**

Minimum — 0.0

Maximum — 30.0

Units — %

Electronic Thermal Protection #4

Program ⇒ Motor Parameters ⇒ **Motor Set #4**

The **Motor #4 Electronic Thermal Protection** parameter specifies the motor overload current level for motor set #4. This value is entered as either a percentage of the full load rating of the ASD or as the FLA of the motor.

The unit of measurement for this parameter may be set to **Amps (V/A)** or it may be set as a percentage of the ASD rating. The name-plated FLA of the motor may be entered directly when **Amps** is selected as the unit of measurement (see **F701** to change the display unit).

Electronic Thermal Protection settings (#1 – #4) will be displayed in **Amps** if the **EOI** display units are set to **V/A** rather than **%**.

Direct Access Number — F181

Parameter Type — **Numerical**

Factory Default — **100.0**

Changeable During Run — **Yes**

Minimum — 10.0

Maximum — 100.0

Units — %

V/f Adjustment Coefficient

Program ⇒ Special Control Parameters ⇒ Special Parameters ⇒ **V/f Adjustment Coefficient**

This parameter may be used in the **Constant Torque** or the **Variable Torque** modes only and should be adjusted gradually to improve the application-specific torque requirements. The **Torque Boost** setting (**F016**) may be adjusted to improve the low-frequency torque performance.

Note: *The **Torque Boost** setting should be adjusted gradually before attempting performance corrections using this parameter.*

Direct Access Number — F183

Parameter Type — **Numerical**

Factory Default — **32**

Changeable During Run — **Yes**

Minimum — 0

Maximum — 255

Custom V/f Five-Point Setting #1 Frequency

Program ⇒ Special Control Parameters ⇒ **V/f Five-Point Setting**

The **Custom V/f Five-Point Setting #1 Frequency** setting establishes the frequency that is to be associated with the voltage setting of **F191 (Custom V/f Five-Point Setting #1 Voltage)**.

The V/f five-point settings define a custom volts per hertz relationship for the startup output of the ASD.

To enable this function, set the **V/f Pattern (F015)** selection to **Custom V/f Curve**.

Custom V/f Curves may be useful in starting high inertia loads such as rotary drum vacuum filters.

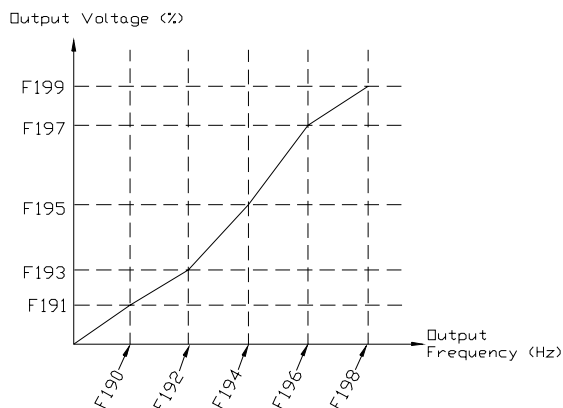

Direct Access Number — F190

Parameter Type — **Numerical**

Factory Default — **0.0**

Changeable During Run — **No**

Minimum — 0.0

Maximum — 299

Units — Hz

Custom V/f Five-Point Setting #1 Voltage

Program ⇒ Special Control Parameters ⇒ **V/f Five-Point Setting**

The **Custom V/f Five-Point Setting #1 Voltage** establishes the percentage of the output voltage that is to be associated with the frequency setting of **F190 (Custom V/f Five-Point Setting #1 Frequency)**.

See **F190** for additional information on custom V/f curves.

Direct Access Number — F191

Parameter Type — **Numerical**

Factory Default — **0.00**

Changeable During Run — **No**

Minimum — 0.0

Maximum — 100.0

Units — %

Custom V/f Five-Point Setting #2 Frequency

Program ⇒ Special Control Parameters ⇒ **V/f Five-Point Setting**

The **Custom V/f Five Point Setting #2 Frequency** sets the frequency to be associated with parameter **F193 (Custom V/f Five Point Setting #2 Voltage)**.

See **F190** for additional information on custom V/f curves.

Direct Access Number — F192

Parameter Type — **Numerical**

Factory Default — **0.0**

Changeable During Run — **No**

Minimum — 0.0

Maximum — 299

Units — Hz

Custom V/f Five-Point Setting #2 Voltage

Program ⇒ Special Control Parameters ⇒ **V/f Five-Point Setting**

The **Custom V/f Five-Point Setting #2 Voltage** establishes the percentage of the output voltage that is to be associated with the frequency setting of **F192 (Custom V/f Five Point Setting #2 Frequency)**.

See **F190** for additional information on custom V/f curves.

Direct Access Number — F193

Parameter Type — **Numerical**

Factory Default — **0.0**

Changeable During Run — **No**

Minimum — 0.0

Maximum — 100.0

Units — %

<p>Custom V/f Five-Point Setting #3 Frequency</p> <p>Program ⇒ Special Control Parameters ⇒ V/f Five-Point Setting</p> <p>The Custom V/f Five Point Setting #3 Frequency sets the frequency to be associated with parameter F195 (Custom V/f Five Point Setting #3 Voltage). See F190 for additional information on custom V/f curves.</p>	<p>Direct Access Number — F194</p> <p>Parameter Type — Numerical</p> <p>Factory Default — 0.0</p> <p>Changeable During Run — No</p> <p>Minimum — 0.0</p> <p>Maximum — 299</p> <p>Units — Hz</p>
<p>Custom V/f Five-Point Setting #3 Voltage</p> <p>Program ⇒ Special Control Parameters ⇒ V/f Five-Point Setting</p> <p>The Custom V/f Five-Point Setting #3 Voltage establishes the percentage of the output voltage that is to be associated with the frequency setting of F194 (Custom V/f Five Point Setting #3 Frequency). See F190 for additional information on custom V/f curves.</p>	<p>Direct Access Number — F195</p> <p>Parameter Type — Numerical</p> <p>Factory Default — 0.0</p> <p>Changeable During Run — No</p> <p>Minimum — 0.0</p> <p>Maximum — 100.0</p> <p>Units — %</p>
<p>Custom V/f Five-Point Setting #4 Frequency</p> <p>Program ⇒ Special Control Parameters ⇒ V/f Five-Point Setting</p> <p>The Custom V/f Five Point Setting #4 Frequency sets the frequency to be associated with parameter F197 (Custom V/f Five Point Setting #4 Voltage). See F190 for additional information on custom V/f curves.</p>	<p>Direct Access Number — F196</p> <p>Parameter Type — Numerical</p> <p>Factory Default — 0.0</p> <p>Changeable During Run — No</p> <p>Minimum — 0.0</p> <p>Maximum — 299</p> <p>Units — Hz</p>
<p>Custom V/f Five-Point Setting #4 Voltage</p> <p>Program ⇒ Special Control Parameters ⇒ V/f Five-Point Setting</p> <p>The Custom V/f Five-Point Setting #4 Voltage establishes the percentage of the output voltage that is to be associated with the frequency setting of F196 (Custom V/f Five Point Setting #4 Frequency). See F190 for additional information on custom V/f curves.</p>	<p>Direct Access Number — F197</p> <p>Parameter Type — Numerical</p> <p>Factory Default — 0.0</p> <p>Changeable During Run — No</p> <p>Minimum — 0.0</p> <p>Maximum — 100.0</p> <p>Units — %</p>
<p>Custom V/f Five-Point Setting #5 Frequency</p> <p>Program ⇒ Special Control Parameters ⇒ V/f Five-Point Setting</p> <p>The Custom V/f Five Point Setting #5 Frequency sets the frequency to be associated with parameter F199 (Custom V/f Five Point Setting #5 Voltage). See F190 for additional information on custom V/f curves.</p>	<p>Direct Access Number — F198</p> <p>Parameter Type — Numerical</p> <p>Factory Default — 0.0</p> <p>Changeable During Run — No</p> <p>Minimum — 0.0</p> <p>Maximum — 299</p> <p>Units — Hz</p>
<p>Custom V/f Five-Point Setting #5 Voltage</p> <p>Program ⇒ Special Control Parameters ⇒ V/f Five-Point Setting</p> <p>The Custom V/f Five-Point Setting #5 Voltage establishes the percentage of the output voltage that is to be associated with the frequency setting of F198 (Custom V/f Five Point Setting #5 Frequency). See F190 for additional information on custom V/f curves.</p>	<p>Direct Access Number — F199</p> <p>Parameter Type — Numerical</p> <p>Factory Default — 0.0</p> <p>Changeable During Run — No</p> <p>Minimum — 0.0</p> <p>Maximum — 100.0</p> <p>Units — %</p>

Reference Priority Selection

Program ⇒ Fundamental Parameters ⇒ Standard Mode Selection ⇒
Reference Priority Selection

Either **Frequency Mode #1** or **Frequency Mode #2** may control the output frequency of the ASD. This parameter determines which of the two will control the output frequency and the conditions in which control will be switched from one to the other.

Settings:

- Frequency Source #1
- Frequency Source #2
- Frequency Source #1 Priority
- Frequency Source #2 Priority
- Frequency Source Priority Switching

The **Frequency Source #1** or **#2** setting specifies the source of the input frequency command signal. These settings are performed in **F004** and **F207**, respectively.

If **Frequency Source #1** is selected here, the ASD will follow the settings of **F004**. If **Frequency Source #2** is selected here, the ASD will follow the settings of **F207**.

The **Frequency Source #1 Priority** and **Frequency Source #2 Priority** selections are used in conjunction with the **Mode #1/#2 Switching Frequency** setting (**F208**). Parameter **F208** establishes a threshold frequency that will be used as a reference when determining when to switch output control between the **Frequency Mode #1** setting and the **Frequency Mode #2** setting.

If **Frequency Source #1 Priority** is selected here and the commanded frequency of **Frequency Source #1** exceeds the **F208** setting, the **Frequency Mode #1** setting has priority over the **Frequency Mode #2** setting.

If **Frequency Source #2 Priority** is selected here and the commanded frequency of **Frequency Source #2** exceeds the **F208** setting, the **Frequency Mode #2** setting has priority over **Frequency Mode #1** setting.

Frequency Source Priority Switching allows for a preconfigured input terminal to activate **Frequency Source #1** or **Frequency Source #2**. Any unused programmable discrete input terminals may be programmed as the **Frequency Priority** switching terminal.

Direct Access Number — F200

Parameter Type — Selection List

Factory Default — Frequency Source #1

Changeable During Run — Yes

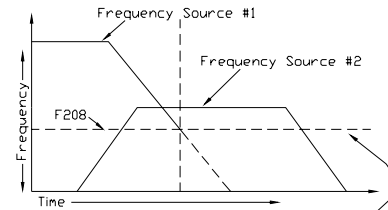

Once the commanded frequency exceeds the F208 value, the setting of parameter F200 determines if the #1 or the #2 frequency command source controls the ASD output.

VI/II Speed Reference #1

Program ⇒ Frequency Setting Parameters ⇒ Speed Reference Setpoints ⇒ **VI/II**

This parameter is used to set the gain and bias of the **VI/II** input terminal when the **VI/II** terminal is used as the control input while operating in the **Speed Control** mode or the **Torque Control** mode.

Note: See note on pg. 47 for further information on the **VI/II** terminal.

VI/II Input Speed Control Setup

Perform the following setup to allow the system to receive **Speed** control input at the **VI/II** input terminal:

- Program ⇒ Fundamental Parameters ⇒ Standard Mode Selection ⇒ Frequency Mode #1 ⇒ **VI/II**.
- Program ⇒ Fundamental Parameters ⇒ Standard Mode Selection ⇒ Command Mode ⇒ **Use Control Terminal Strip**.
- Set **VI/II Speed Reference #1 (F201)** — the input signal level that represents **VI/II Speed Frequency #1**.
- Set **VI/II Speed Frequency #1 (F202)**.
- Set **VI/II Speed Reference #2 (F203)** — the input signal level that represents **VI/II Speed Frequency #2**.
- Set **VI/II Speed Frequency #2 (F204)**.
- Provide a **Run** command (**F** and/or **R**).

Once set, as the **VI** input voltage or the **II** current changes, the output frequency of the ASD will vary in accordance with the above settings.

This parameter sets **VI/II Speed Reference #1** and is the input signal level that is associated with the setting of **VI/II Speed Frequency #1** while operating in the **Speed Control** mode.

VI/II Input Torque Control Setup

Perform the following setup to allow the system to receive **Torque** control input at the **VI/II** input terminal:

- Program ⇒ Fundamental Parameters ⇒ Standard Mode Selection ⇒ Frequency Mode #1 ⇒ **VI/II**.
- Program ⇒ Fundamental Parameters ⇒ Standard Mode Selection ⇒ Command Mode ⇒ **Use Control Terminal Strip**.
- Set **VI/II Speed Reference #1 (F201)** — the input signal level that represents **VI/II Torque Reference Setpoint #1**.
- Set **VI/II Torque Reference Setpoint #1 (F205)**.
- Set **VI/II Speed Reference #2 (F203)** — the input signal level that represents **VI/II Torque Reference Setpoint #2**.
- Set **VI/II Torque Reference Setpoint #2 (F206)**.
- Provide a **Run** command (**F** and/or **R**).

Once set, as the **VI** input voltage or the **II** current changes, the output torque of the ASD will vary in accordance with the above settings.

This parameter sets **VI/II Speed Reference #1** and is the input signal level that is associated with the setting of **VI/II Torque Reference Setpoint #1** while operating in the **Torque Control** mode.

Direct Access Number — **F201**

Parameter Type — **Numerical**

Factory Default — **20.0**

Changeable During Run — **Yes**

Minimum — **0.0**

Maximum — **100.0**

Units — **%**

Frequency Settings

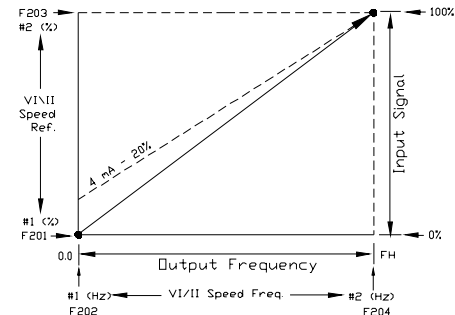

Note: The default value for parameter **F201** is 20%. The **II** input is commonly used for the 4 – 20 mA current loop signal where 4 mA equals 20% of a 20 mA signal. If the **VI** input is used (0 – 10 VDC input), this parameter may be changed to 0.0% (of the input signal).

Note: The speed control response may be further trimmed by adjusting the **Bias** and **Gain** settings.

Torque Settings

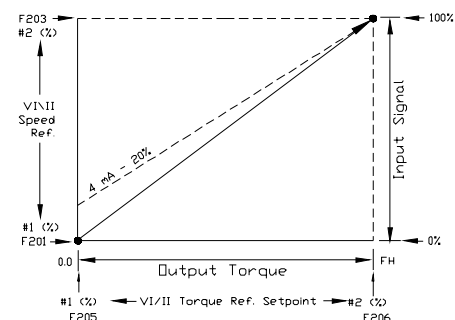

<p>VI/II Speed Frequency #1</p> <p>Program ⇒ Frequency Setting Parameters ⇒ Speed Reference Setpoints ⇒ VI/II</p> <p>This parameter is used to set the gain and bias of the VI/II input terminal when the VI/II terminal is used as the control input while operating in the Speed Control mode.</p> <p>See VI/II Speed Reference #1 (F201) for further information on this setting.</p> <p>This parameter sets VI/II Speed Frequency #1 and is the frequency that is associated with the setting of VI/II Speed Reference #1 while operating in the Speed Control mode.</p>	<p>Direct Access Number — F202</p> <p>Parameter Type — Numerical</p> <p>Factory Default — 0.0</p> <p>Changeable During Run — Yes</p> <p>Minimum — 0.0</p> <p>Maximum — Max. Freq. (F011)</p> <p>Units — Hz</p>
<p>VI/II Speed Reference #2</p> <p>Program ⇒ Frequency Setting Parameters ⇒ Speed Reference Setpoints ⇒ VI/II</p> <p>This parameter is used to set the gain and bias of the VI/II input terminal when the VI/II terminal is used as the control input while operating in the Speed Control mode or the Torque Control mode.</p> <p>See VI/II Speed Reference #1 for further information on this setting when used for Speed control or Torque control.</p> <p>This parameter sets the VI/II input level that is associated with VI/II Speed Frequency #2 while operating in the Speed control mode or is associated with the VI/II Torque Reference Setpoint #2 while operating in the Torque control mode.</p>	<p>Direct Access Number — F203</p> <p>Parameter Type — Numerical</p> <p>Factory Default — 100.00</p> <p>Changeable During Run — Yes</p> <p>Minimum — 0.0</p> <p>Maximum — 100.0</p> <p>Units — %</p>
<p>VI/II Speed Frequency #2</p> <p>Program ⇒ Frequency Setting Parameters ⇒ Speed Reference Setpoints ⇒ VI/II</p> <p>This parameter is used to set the gain and bias of the VI/II input terminal when the VI/II terminal is used as the control input while operating in the Speed Control mode.</p> <p>See VI/II Speed Reference #1 for further information on this setting when used for Speed control.</p> <p>This parameter sets the output frequency that is associated with VI/II Speed Reference #2 setting while operating in the Speed control mode.</p>	<p>Direct Access Number — F204</p> <p>Parameter Type — Numerical</p> <p>Factory Default — 80.00</p> <p>Changeable During Run — Yes</p> <p>Minimum — 0.0</p> <p>Maximum — Max. Freq. (F011)</p> <p>Units — Hz</p>
<p>VI/II Torque Reference Setpoint #1</p> <p>Program ⇒ Torque Setting Parameters ⇒ Setpoints ⇒ VI/II</p> <p>This parameter is used to set the gain and bias of the VI/II input terminal when the VI/II terminal is used as the control input while operating in the Torque Control mode.</p> <p>This is accomplished by establishing an associated V/f output pattern for a given VI/II input level.</p> <p>See VI/II Speed Reference #1 for further information on this setting.</p> <p>This parameter sets VI/II Torque Reference Setpoint #1 and is the output torque value that is associated with the setting of VI/II Speed Reference #1 while operating in the Torque control mode.</p>	<p>Direct Access Number — F205</p> <p>Parameter Type — Numerical</p> <p>Factory Default — 0.00</p> <p>Changeable During Run — Yes</p> <p>Minimum — 0.00</p> <p>Maximum — 250.0</p> <p>Units — %</p>

VI/II Torque Reference Setpoint #2

Program ⇒ Torque Setting Parameters ⇒ Setpoints ⇒ **VI/II**

This parameter is used to set the gain and bias of the **VI/II** input terminal when the **VI/II** terminal is used as the control input while operating in the **Torque Control** mode.

This is accomplished by establishing an associated **V/f** output pattern for a given **VI/II** input level.

See **VI/II Speed Reference #1** for further information on this setting.

This parameter sets **VI/II Torque Reference Setpoint #2** and is the output torque value that is associated with setting of **VI/II Speed Reference #2** while operating in the **Torque** control mode.

Direct Access Number — F206

Parameter Type — **Numerical**

Factory Default — **100.00**

Changeable During Run — **Yes**

Minimum — 0.00

Maximum — 250.0

Units — %

Frequency Mode #2

Program ⇒ Fundamental Parameters ⇒ **Standard Mode Selection**

This parameter selects the source of the frequency command signal to be used as **Frequency Mode #2** in the event that **Frequency Mode #1** is disabled or if **Frequency Mode #2** is set up as the primary control parameter. See **F004** and **F200** for additional information on this setting.

Settings:

Use VI/II

Use RR

Use RX

Use Option Card RX2

Use LED Keypad Option

Use Binary/BCD Input

Use Common Serial (TTL)

Use RS232/RS485

Use Communication Card

Use Motorized Pot. Simulation

Use Pulse Input Option

Direct Access Number — F207

Parameter Type — **Selection List**

Factory Default — **VI/II**

Changeable During Run — **Yes**

Mode #1/#2 Switching Frequency

Program ⇒ Fundamental Parameters ⇒ Standard Mode Selection ⇒ **Mode #1/#2 Switching Frequency**

This parameter sets the threshold frequency that will be used in **F200** to determine if **Frequency Source #1** or **#2** will control the output of the ASD.

See **F200** for additional information on this setting.

Direct Access Number — F208

Parameter Type — **Numerical**

Factory Default — **1.0**

Changeable During Run — **Yes**

Minimum — 0.1

Maximum — **Max. Freq. (F011)**

Units — Hz

Analog Input Filter

Program ⇒ Frequency Setting Parameters ⇒ **Analog Filter**

Analog filtering is applied after the analog reference signal is converted to a digital signal. The type of filtering used is **Rolling Average** over time.

Settings:

- None
- Small
- Medium
- Large

The analog input signal is sampled and converted to a digital signal. With no filtering applied, the digital value from the conversion is scaled for use by the microprocessor of the ASD.

If the filtering selection is **Small**, the ASD averages the last 5 sampled (digital) values. The rolling average is updated (every 4 μ S) and scaled for use by the microprocessor.

If the filtering selection is **Medium**, the ASD averages the last 20 sampled (digital) values. The rolling average is updated (every 4 μ S) and scaled for use by the microprocessor.

If the filtering selection is **Large**, the ASD averages the last 50 sampled (digital) values. The rolling average is updated (every 4 μ S) and scaled for use by the microprocessor.

False responses to electrical noise are eliminated with no loss in bandwidth because the value used by the drive is the average value of several samples.

Direct Access Number — F209

Parameter Type — **Selection List**

Factory Default — **None**

Changeable During Run — **Yes**

RR Speed Reference #1

Program ⇒ Frequency Setting Parameters ⇒ Speed Reference Setpoints ⇒ **RR**

This parameter is used to set the gain and bias of the **RR** input terminal when the **RR** terminal is used as the control input while operating in the **Speed Control** mode or the **Torque Control** mode.

RR Input Speed Control Setup

Perform the following setup to allow the system to receive **Speed** control input at the **RR** input terminal:

- Program ⇒ Fundamental Parameters ⇒ Standard Mode Selection ⇒ Frequency Mode #1 ⇒ **RR**.
- Program ⇒ Fundamental Parameters ⇒ Standard Mode Selection ⇒ Command Mode ⇒ **Use Control Terminal Strip**.
- Set **RR Speed Reference #1 (F210)** — the input signal level that represents **RR Speed Frequency #1**.
- Set **RR Speed Frequency #1 (F211)**.
- Set **RR Speed Reference #2 (F212)** — the input signal level that represents **RR Speed Frequency #2**.
- Set **RR Speed Frequency #2 (F213)**.
- Provide a **Run** command (**F** and/or **R**).

Once set, as the **RR** input changes, the output frequency of the ASD will vary in accordance with the above settings.

This parameter sets **RR Speed Reference #1** and is the input signal level that is associated with the setting of **RR Speed Frequency #1** while operating in the **Speed Control** mode.

RR Input Torque Control Setup

Perform the following setup to allow the system to receive **Torque** control input at the **RR** input terminal:

- Program ⇒ Fundamental Parameters ⇒ Standard Mode Selection ⇒ Frequency Mode #1 ⇒ **RR**.
- Program ⇒ Fundamental Parameters ⇒ Standard Mode Selection ⇒ Command Mode ⇒ **Use Control Terminal Strip**.
- Set **RR Speed Reference #1 (F210)** — the input signal level that represents **RR Torque Reference Setpoint #1**.
- Set **RR Torque Reference Setpoint #1 (F214)**.
- Set **RR Speed Reference #2 (F212)** — the input signal level that represents **RR Torque Reference Setpoint #2**.
- Set **RR Torque Reference Setpoint #2 (F215)**.
- Provide a **Run** command (**F** and/or **R**).

Once set, as the **RR** input changes, the output torque of the ASD will vary in accordance with the above settings.

This parameter sets **RR Speed Reference #1** and is the input signal level that is associated with the setting of **RR Torque Reference Setpoint #1** while operating in the **Torque Control** mode.

Direct Access Number — **F210**

Parameter Type — **Numerical**

Factory Default — **0.0**

Changeable During Run — **Yes**

Minimum — **0.0**

Maximum — **100.0**

Units — **%**

Frequency Settings

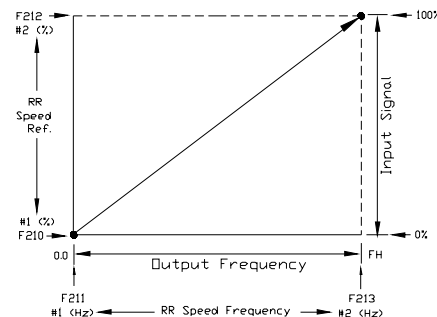

Note: *The speed control response may be further trimmed by adjusting the Bias and Gain settings.*

Torque Settings

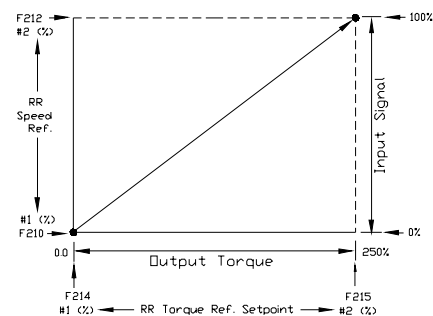

<p>RR Speed Frequency #1</p> <p>Program ⇒ Frequency Setting Parameters ⇒ Speed Reference Setpoints ⇒ RR</p> <p>This parameter is used to set the gain and bias of the RR input terminal when the RR terminal is used as the control input while operating in the Speed Control mode.</p> <p>See RR Speed Reference #1 (F210) for further information on this setting.</p> <p>This parameter sets RR Speed Frequency #1 and is the frequency that is associated with the setting of RR Speed Reference #1 while operating in the Speed Control mode.</p>	<p>Direct Access Number — F211</p> <p>Parameter Type — Numerical</p> <p>Factory Default — 0.0</p> <p>Changeable During Run — Yes</p> <p>Minimum — 0.0</p> <p>Maximum — Max. Freq. (F011)</p> <p>Units — Hz</p>
<p>RR Speed Reference #2</p> <p>Program ⇒ Frequency Setting Parameters ⇒ Speed Reference Setpoints ⇒ RR</p> <p>This parameter is used to set the gain and bias of the RR input terminal when the RR terminal is used as the control input while operating in the Speed Control mode or the Torque Control mode.</p> <p>See RR Speed Reference #1 for further information on this setting when used for Speed control or Torque control.</p> <p>This parameter sets the RR input level that is associated with RR Speed Frequency #2 while operating in the Speed control mode or is associated with the RR Torque Reference Setpoint #2 while operating in the Torque control mode.</p>	<p>Direct Access Number — F212</p> <p>Parameter Type — Numerical</p> <p>Factory Default — 100.00</p> <p>Changeable During Run — Yes</p> <p>Minimum — 0.0</p> <p>Maximum — 100.0</p> <p>Units — %</p>
<p>RR Speed Frequency #2</p> <p>Program ⇒ Frequency Setting Parameters ⇒ Speed Reference Setpoints ⇒ RR</p> <p>This parameter is used to set the gain and bias of the RR input terminal when the RR terminal is used as the control input while operating in the Speed Control mode.</p> <p>See RR Speed Reference #1 for further information on this setting when used for Speed control.</p> <p>This parameter sets RR Speed Frequency #2 and is the frequency that is associated with the setting of RR Speed Reference #2 while operating in the Speed Control mode.</p>	<p>Direct Access Number — F213</p> <p>Parameter Type — Numerical</p> <p>Factory Default — 80.00</p> <p>Changeable During Run — Yes</p> <p>Minimum — 0.0</p> <p>Maximum — Max. Freq. (F011)</p> <p>Units — Hz</p>
<p>RR Torque Reference Setpoint #1</p> <p>Program ⇒ Torque Setting Parameters ⇒ Setpoints ⇒ RR</p> <p>This parameter is used to set the gain and bias of the RR input terminal when the RR terminal is used as the control input while operating in the Torque Control mode.</p> <p>This is accomplished by establishing an associated V/f output pattern for a given RR input level.</p> <p>See RR Speed Reference #1 for further information on this setting.</p> <p>This parameter sets RR Torque Reference Setpoint #1 and is the output torque value that is associated with the setting of RR Speed Reference #1 while operating in the Torque control mode.</p>	<p>Direct Access Number — F214</p> <p>Parameter Type — Numerical</p> <p>Factory Default — 0.00</p> <p>Changeable During Run — Yes</p> <p>Minimum — 0.00</p> <p>Maximum — 250.0</p> <p>Units — %</p>

RR Torque Reference Setpoint #2

Program ⇒ Torque Setting Parameters ⇒ Setpoints ⇒ **RR**

This parameter is used to set the gain and bias of the **RR** input terminal when the **RR** terminal is used as the control input while operating in the **Torque Control** mode.

This is accomplished by establishing an associated **V/f** output pattern for a given **RR** input level.

See **RR Speed Reference #1** for further information on this setting.

This parameter sets **RR Torque Reference Setpoint #2** and is the output torque value that is associated with setting of **RR Speed Reference #2** while operating in the **Torque** control mode.

Direct Access Number — F215

Parameter Type — Numerical

Factory Default — 100.00

Changeable During Run — Yes

Minimum — 0.00

Maximum — 250.0

Units — %

RX Speed Reference #1

Program ⇒ Frequency Setting Parameters ⇒ Speed Reference Setpoints ⇒ **RX**

This parameter is used to set the gain and bias of the **RX** input terminal when the **RX** terminal is used as the control input while operating in the **Speed Control** mode or the **Torque Control** mode.

RX Input Speed Control Setup

Perform the following setup to allow the system to receive **Speed** control input at the **RX** input terminal:

- Program ⇒ Fundamental Parameters ⇒ Standard Mode Selection ⇒ Frequency Mode #1 ⇒ **RX**.
- Program ⇒ Fundamental Parameters ⇒ Standard Mode Selection ⇒ Command Mode ⇒ **Use Control Terminal Strip**.
- Set **RX Speed Reference #1 (F216)** — the input signal level that represents **RX Speed Frequency #1**.
- Set **RX Speed Frequency #1 (F217)**.
- Set **RX Speed Reference #2 (F218)** — the input signal level that represents **RX Speed Frequency #2**.
- Set **RX Speed Frequency #2 (F219)**.
- Provide a **Run** command (**F** and/or **R**).

Once set, as the **RX** input changes, the output frequency of the ASD will vary in accordance with the above settings.

This parameter sets **RX Speed Reference #1** and is the input signal level that is associated with the setting of **RX Speed Frequency #1** while operating in the **Speed Control** mode.

RX Input Torque Control Setup

Perform the following setup to allow the system to receive **Torque** control input at the **RX** input terminal:

- Program ⇒ Fundamental Parameters ⇒ Standard Mode Selection ⇒ Frequency Mode #1 ⇒ **RX**.
- Program ⇒ Fundamental Parameters ⇒ Standard Mode Selection ⇒ Command Mode ⇒ **Use Control Terminal Strip**.
- Set **RX Speed Reference #1 (F216)** — the input signal level that represents **RX Torque Reference Setpoint #1**.
- Set **RX Torque Reference Setpoint #1 (F220)**.
- Set **RX Speed Reference #2 (F218)** — the input signal level that represents **RX Torque Reference Setpoint #2**.
- Set **RX Torque Reference Setpoint #2 (F221)**.
- Provide a **Run** command (**F** and/or **R**).

Once set, as the **RX** input changes, the output torque of the ASD will vary in accordance with the above settings.

This parameter sets **RX Speed Reference #1** and is the input signal level that is associated with the setting of **RX Torque Reference Setpoint #1** while operating in the **Torque Control** mode.

Direct Access Number — F216

Parameter Type — Numerical

Factory Default — 00.0

Changeable During Run — Yes

Minimum — -100.0

Maximum — 100.0

Units — %

Frequency Settings

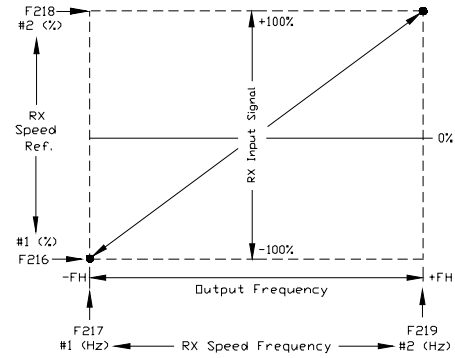

Note: *The speed control response may be further trimmed by adjusting the Bias and Gain settings.*

Torque Settings

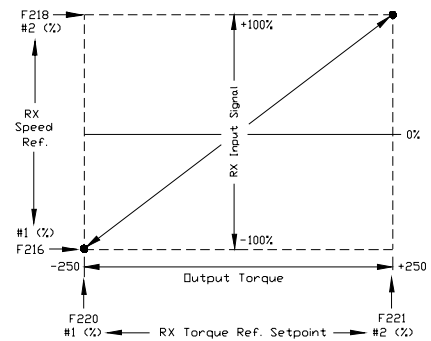

<p>RX Speed Frequency #1</p> <p>Program ⇒ Frequency Setting Parameters ⇒ Speed Reference Setpoints ⇒ RX</p> <p>This parameter is used to set the gain and bias of the RX input terminal when the RX terminal is used as the control input while operating in the Speed Control mode.</p> <p>See RX Speed Reference #1 (F216) for further information on this setting.</p> <p>This parameter sets RX Speed Frequency #1 and is the frequency that is associated with the setting of RX Speed Reference #1 while operating in the Speed Control mode.</p>	<p>Direct Access Number — F217</p> <p>Parameter Type — Numerical</p> <p>Factory Default — 0.0</p> <p>Changeable During Run — Yes</p> <p>Minimum — -Max. Freq. (F011)</p> <p>Maximum — Max. Freq. (F011)</p> <p>Units — Hz</p>
<p>RX Speed Reference #2</p> <p>Program ⇒ Frequency Setting Parameters ⇒ Speed Reference Setpoints ⇒ RX</p> <p>This parameter is used to set the gain and bias of the RX input terminal when the RX terminal is used as the control input while operating in the Speed Control mode or the Torque Control mode.</p> <p>See RX Speed Reference #1 for further information on this setting when used for Speed control or Torque control.</p> <p>This parameter sets the RX input level that is associated with RX Speed Frequency #2 while operating in the Speed control mode or is associated with the RX Torque Reference Setpoint #2 while operating in the Torque control mode.</p>	<p>Direct Access Number — F218</p> <p>Parameter Type — Numerical</p> <p>Factory Default — 100.00</p> <p>Changeable During Run — Yes</p> <p>Minimum — -100.0</p> <p>Maximum — 100.0</p> <p>Units — %</p>
<p>RX Speed Frequency #2</p> <p>Program ⇒ Frequency Setting Parameters ⇒ Speed Reference Setpoints ⇒ RX</p> <p>This parameter is used to set the gain and bias of the RX input terminal when the RX terminal is used as the control input while operating in the Speed Control mode.</p> <p>See RX Speed Reference #1 for further information on this setting when used for Speed control.</p> <p>This parameter sets RX Speed Frequency #2 and is the frequency that is associated with the setting of RX Speed Reference #2 while operating in the Speed Control mode.</p>	<p>Direct Access Number — F219</p> <p>Parameter Type — Numerical</p> <p>Factory Default — 80.00</p> <p>Changeable During Run — Yes</p> <p>Minimum — -Max. Freq. (F011)</p> <p>Maximum — Max. Freq. (F011)</p> <p>Units — Hz</p>
<p>RX Torque Reference Setpoint #1</p> <p>Program ⇒ Torque Setting Parameters ⇒ Setpoints ⇒ RX</p> <p>This parameter is used to set the gain and bias of the RX input terminal when the RX terminal is used as the control input while operating in the Torque Control mode.</p> <p>This is accomplished by establishing an associated V/f output pattern for a given RX input level.</p> <p>See RX Speed Reference #1 for further information on this setting.</p> <p>This parameter sets RX Torque Reference Setpoint #1 and is the output torque value that is associated with the setting of RX Speed Reference #1 while operating in the Torque control mode.</p>	<p>Direct Access Number — F220</p> <p>Parameter Type — Numerical</p> <p>Factory Default — 0.00</p> <p>Changeable During Run — Yes</p> <p>Minimum — -250.00</p> <p>Maximum — 250.00</p> <p>Units — %</p>

RX Torque Reference Setpoint #2

Program ⇒ Torque Setting Parameters ⇒ Setpoints ⇒ **RX**

This parameter is used to set the gain and bias of the **RX** input terminal when the **RX** terminal is used as the control input while operating in the **Torque Control** mode.

This is accomplished by establishing an associated **V/f** output pattern for a given **RX** input level.

See **RX Speed Reference #1** for further information on this setting.

This parameter sets **RX Torque Reference Setpoint #2** and is the output torque value that is associated with setting of **RX Speed Reference #2** while operating in the **Torque** control mode.

Direct Access Number — F221

Parameter Type — **Numerical**

Factory Default — **100.00**

Changeable During Run — **Yes**

Minimum — -250.00

Maximum — 250.00

Units — %

RX2 Speed Reference #1

Program ⇒ Frequency Setting Parameters ⇒ Speed Reference Setpoints ⇒ **RX2**

This parameter is used to set the gain and bias of the **RX2** input terminal when the **RX2** terminal is used as the control input while operating in the **Speed Control** mode or the **Torque Control** mode.

RX2 Input Speed Control Setup

Perform the following setup to allow the system to receive **Speed** control input at the **RX2** input terminal:

- Program ⇒ Fundamental Parameters ⇒ Standard Mode Selection ⇒ Frequency Mode #1 ⇒ **RX2**.
- Program ⇒ Fundamental Parameters ⇒ Standard Mode Selection ⇒ Command Mode ⇒ **Use Control Terminal Strip**.
- Set **RX2 Speed Reference #1 (F222)** — the input signal level that represents **RX2 Speed Frequency #1**.
- Set **RX2 Speed Frequency #1 (F223)**.
- Set **RX2 Speed Reference #2 (F224)** — the input signal level that represents **RX2 Speed Frequency #2**.
- Set **RX2 Speed Frequency #2 (F225)**.
- Provide a **Run** command (**F** and/or **R**).

Once set, as the **RX2** input changes, the output frequency of the ASD will vary in accordance with the above settings.

This parameter sets **RX2 Speed Reference #1** and is the input signal level that is associated with the setting of **RX2 Speed Frequency #1** while operating in the **Speed Control** mode.

RX2 Input Torque Control Setup

Perform the following setup to allow the system to receive **Torque** control input at the **RX2** input terminal:

- Program ⇒ Fundamental Parameters ⇒ Standard Mode Selection ⇒ Frequency Mode #1 ⇒ **RX2**.
- Program ⇒ Fundamental Parameters ⇒ Standard Mode Selection ⇒ Command Mode ⇒ **Use Control Terminal Strip**.
- Set **RX2 Speed Reference #1 (F222)** — the input signal level that represents **RX2 Torque Reference Setpoint #1**.
- Set **RX2 Torque Reference Setpoint #1 (F226)**.
- Set **RX2 Speed Reference #2 (F224)** — the input signal level that represents **RX2 Torque Reference Setpoint #2**.
- Set **RX2 Torque Reference Setpoint #2 (F227)**.
- Provide a **Run** command (**F** and/or **R**).

Once set, as the **RX2** input changes, the output torque of the ASD will vary in accordance with the above settings.

This parameter sets **RX2 Speed Reference #1** and is the input signal level that is associated with the setting of **RX2 Torque Reference Setpoint #1** while operating in the **Torque Control** mode.

Direct Access Number — **F222**

Parameter Type — **Numerical**

Factory Default — **00.0**

Changeable During Run — **Yes**

Minimum — **-100.0**

Maximum — **100.0**

Units — **%**

Frequency Settings

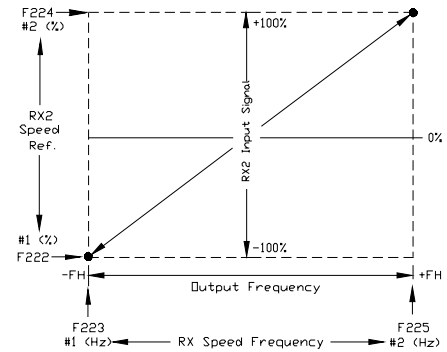

Note: *The speed control response may be further trimmed by adjusting the Bias and Gain settings.*

Torque Settings

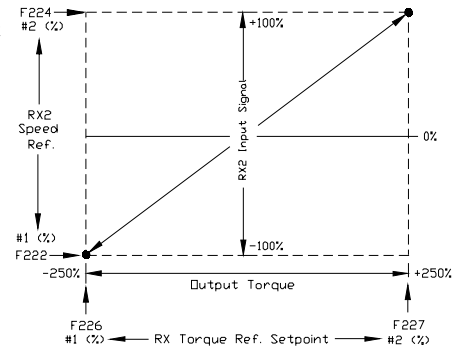

<p>RX2 Speed Frequency #1</p> <p>Program ⇒ Frequency Setting Parameters ⇒ Speed Reference Setpoints ⇒ RX2</p> <p>This parameter is used to set the gain and bias of the RX2 input terminal when the RX2 terminal is used as the control input while operating in the Speed Control mode.</p> <p>See RX2 Speed Reference #1 (F222) for further information on this setting.</p> <p>This parameter sets RX2 Speed Frequency #1 and is the frequency that is associated with the setting of RX2 Speed Reference #1 while operating in the Speed Control mode.</p>	<p>Direct Access Number — F223</p> <p>Parameter Type — Numerical</p> <p>Factory Default — 0.0</p> <p>Changeable During Run — Yes</p> <p>Minimum — -Max. Freq. (F011)</p> <p>Maximum — Max. Freq. (F011)</p> <p>Units — Hz</p>
<p>RX2 Speed Reference #2</p> <p>Program ⇒ Frequency Setting Parameters ⇒ Speed Reference Setpoints ⇒ RX2</p> <p>This parameter is used to set the gain and bias of the RX2 input terminal when the RX2 terminal is used as the control input while operating in the Speed Control mode or the Torque Control mode.</p> <p>See RX2 Speed Reference #1 for further information on this setting when used for Speed control or Torque control.</p> <p>This parameter sets the RX2 input level that is associated with RX2 Speed Frequency #2 while operating in the Speed control mode or is associated with the RX2 Torque Reference Setpoint #2 while operating in the Torque control mode.</p>	<p>Direct Access Number — F224</p> <p>Parameter Type — Numerical</p> <p>Factory Default — 100.00</p> <p>Changeable During Run — Yes</p> <p>Minimum — -100.0</p> <p>Maximum — 100.0</p> <p>Units — %</p>
<p>RX2 Speed Frequency #2</p> <p>Program ⇒ Frequency Setting Parameters ⇒ Speed Reference Setpoints ⇒ RX2</p> <p>This parameter is used to set the gain and bias of the RX2 input terminal when the RX2 terminal is used as the control input while operating in the Speed Control mode.</p> <p>See RX2 Speed Reference #1 for further information on this setting when used for Speed control.</p> <p>This parameter sets RX2 Speed Frequency #2 and is the frequency that is associated with the setting of RX2 Speed Reference #2 while operating in the Speed Control mode.</p>	<p>Direct Access Number — F225</p> <p>Parameter Type — Numerical</p> <p>Factory Default — 80.00</p> <p>Changeable During Run — Yes</p> <p>Minimum — -Max. Freq. (F011)</p> <p>Maximum — Max. Freq. (F011)</p> <p>Units — Hz</p>
<p>RX2 Torque Reference Setpoint #1</p> <p>Program ⇒ Torque Setting Parameters ⇒ Setpoints ⇒ RX2</p> <p>This parameter is used to set the gain and bias of the RX2 input terminal when the RX2 terminal is used as the control input while operating in the Torque Control mode.</p> <p>This is accomplished by establishing an associated V/f output pattern for a given RX2 input level.</p> <p>See RX2 Speed Reference #1 for further information on this setting.</p> <p>This parameter sets RX2 Torque Reference Setpoint #1 and is the output torque value that is associated with the setting of RX2 Speed Reference #1 while operating in the Torque control mode.</p>	<p>Direct Access Number — F226</p> <p>Parameter Type — Numerical</p> <p>Factory Default — 0.00</p> <p>Changeable During Run — Yes</p> <p>Minimum — -250.00</p> <p>Maximum — 250.00</p> <p>Units — %</p>

RX2 Torque Reference Setpoint #2

Program ⇒ Torque Setting Parameters ⇒ Setpoints ⇒ **RX2**

This parameter is used to set the gain and bias of the **RX2** input terminal when the **RX2** terminal is used as the control input while operating in the **Torque Control** mode.

This is accomplished by establishing an associated **V/f** output pattern for a given **RX2** input level.

See **RX2 Speed Reference #1** for further information on this setting.

This parameter sets **RX2 Torque Reference Setpoint #2** and is the output torque value that is associated with setting of **RX2 Speed Reference #2** while operating in the **Torque** control mode.

Direct Access Number — F227

Parameter Type — **Numerical**

Factory Default — **100.00**

Changeable During Run — **Yes**

Minimum — -250.00

Maximum — 250.00

Units — %

BIN Speed Reference #1

Program ⇒ Frequency Setting Parameters ⇒ Speed Reference Setpoints ⇒ **BIN**

This parameter is used to set the gain and bias of the binary input when the discrete input terminals are used as the control input while operating in the **Speed Control** mode or the **Torque Control** mode.

BIN Input Control Setup

Perform the following setup to allow the system to receive control input at the binary input terminals:

- Program ⇒ Fundamental Parameters ⇒ Standard Mode Selection ⇒ Frequency Mode #1 ⇒ **Use Binary/BCD Input**.
- Program ⇒ Fundamental Parameters ⇒ Standard Mode Selection ⇒ Command Mode ⇒ **Use Control Terminal Strip**.
- Program ⇒ Terminal Selection Parameters ⇒ **Input Terminals**; select and set the desired discrete input terminals to **Binary Bit(s) 0 – 7** (or 0 – MSB) (see [Table 8 on pg. 77](#)). The binary input can control the direction, speed, and/or torque of the motor.

Note: 255_D is the decimal equivalent of the 8-bit BIN word with all input terminals set to one (255 decimal = 11111111 binary).

BIN Speed Control Setup

- Set **BIN Speed Reference #1 (F228)** — the input signal that represents **BIN Speed Frequency #1**.
- Set **BIN Speed Frequency #1 (F229)**.
- Set **BIN Speed Reference #2 (F230)** — the input signal that represents **BIN Speed Frequency #2**.
- Set **BIN Speed Frequency #2 (F231)**.
- Provide a **Run** command (**F** and/or **R**).

Once set, as the binary input signal changes, the output signal of the ASD will vary in accordance with the above settings.

This parameter sets **BIN Speed Reference #1** and is the input signal that is associated with the setting of **BIN Speed Frequency #1** while operating in the **Speed Control** mode.

BIN Torque Control Setup

- Set **BIN Speed Reference #1 (F228)** — the input signal level that represents **BIN Torque Reference Setpoint #1**.
- Set **BIN Torque Reference Setpoint #1 (F232)**.
- Set **BIN Speed Reference #2 (F230)** — the input signal level that represents **BIN Torque Reference Setpoint #2**.
- Set **BIN Torque Reference Setpoint #2 (F233)**.
- Provide a **Run** command (**F** and/or **R**).

Once set, as the binary input signal changes, the output signal of the ASD will vary in accordance with the above settings.

This parameter sets **BIN Speed Reference #1** and is the input signal that is associated with the setting of **BIN Torque Reference Setpoint #1** while operating in the **Torque Control** mode.

Direct Access Number — F228

Parameter Type — Numerical

Factory Default — 0.00

Changeable During Run — Yes

Minimum — 0.0

Maximum — 100.0

Units — %

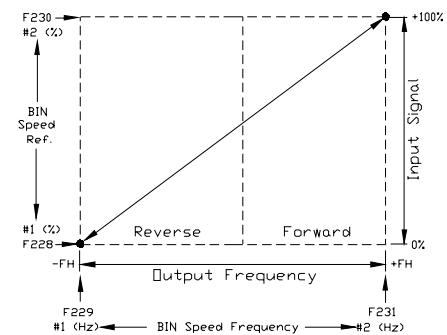
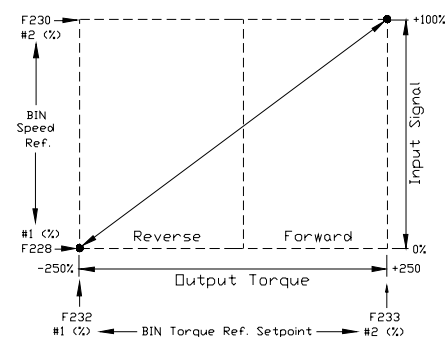
Frequency Settings**Torque Settings**

BIN Speed Frequency #1

Program ⇒ Frequency Setting Parameters ⇒ Speed Reference Setpoints ⇒ **BIN**

This parameter is used to set the gain and bias of the binary input when the discrete input terminals are used as the control input while operating in the **Speed Control** mode.

This parameter sets **BIN Speed Frequency #1** and is the frequency that is associated with the setting of **BIN Speed Reference #1** while operating in the **Speed Control** mode.

See **BIN Speed Reference #1 (F228)** for further information on this setting.

Direct Access Number — F229

Parameter Type — **Numerical**

Factory Default — **0.0**

Changeable During Run — **Yes**

Minimum — -Max. Freq. (F011)

Maximum — Max. Freq. (F011)

Units — Hz

BIN Speed Reference #2

Program ⇒ Frequency Setting Parameters ⇒ Speed Reference Setpoints ⇒ **BIN**

This parameter is used to set the gain and bias of the binary input when the discrete input terminals are used as the control input while operating in the **Speed Control** mode or the **Torque Control** mode.

See **BIN Speed Reference #1** for further information on this setting when used for **Speed** control or **Torque** control.

This parameter sets **BIN Speed Reference #2** and is the input signal that is associated with the setting of **BIN Speed Frequency #1** while operating in the **Speed Control** mode or is associated with the **BIN Torque Reference Setpoint #2** while operating in the **Torque** control mode.

Direct Access Number — F230

Parameter Type — **Numerical**

Factory Default — **100.00**

Changeable During Run — **Yes**

Minimum — 0.0

Maximum — 100.0

Units — %

BIN Speed Frequency #2

Program ⇒ Frequency Setting Parameters ⇒ Speed Reference Setpoints ⇒ **BIN**

This parameter is used to set the gain and bias of the binary input when the discrete input terminals are used as the control input while operating in the **Speed Control** mode.

This parameter sets **BIN Speed Frequency #2** and is the frequency that is associated with the setting of **BIN Speed Reference #1** while operating in the **Speed Control** mode.

See **BIN Speed Reference #1 (F228)** for further information on this setting.

Direct Access Number — F231

Parameter Type — **Numerical**

Factory Default — **80.00**

Changeable During Run — **Yes**

Minimum — -Max. Freq. (F011)

Maximum — Max. Freq. (F011)

Units — Hz

BIN Torque Reference Setpoint #1

Program ⇒ Torque Setting Parameters ⇒ Setpoints ⇒ **BIN**

This parameter is used to set the gain and bias of the binary input when the discrete input terminals are used as the control input while operating in the **Torque Control** mode.

This is accomplished by establishing an associated **V/f** output pattern for a given binary input signal.

See **BIN Speed Reference #1** for further information on this setting.

This parameter sets **BIN Torque Reference Setpoint #1** and is the output torque value that is associated with the setting of **BIN Speed Reference #1** while operating in the **Torque** control mode.

Direct Access Number — F232

Parameter Type — **Numerical**

Factory Default — **0.00**

Changeable During Run — **Yes**

Minimum — -250.0

Maximum — 250.0

Units — %

BIN Torque Reference Setpoint #2

Program ⇒ Torque Setting Parameters ⇒ Setpoints ⇒ **BIN**

This parameter is used to set the gain and bias of the binary input when the discrete input terminals are used as the control input while operating in the **Torque Control** mode.

This is accomplished by establishing an associated **V/f** output pattern for a given binary input signal.

See **BIN Speed Reference #1** for further information on this setting.

This parameter sets **BIN Torque Reference Setpoint #2** and is the output torque value that is associated with setting of **BIN Speed Reference #2** while operating in the **Torque** control mode.

Direct Access Number — F233

Parameter Type — Numerical

Factory Default — 100.00

Changeable During Run — Yes

Minimum — -250.0

Maximum — 250.0

Units — %

PG Speed Reference #1

Program ⇒ Frequency Setting Parameters ⇒ Speed Reference Setpoints ⇒ **PG**

This parameter is used to set the gain and bias of the **PG** input terminal when a shaft-mounted encoder is used as the feedback transducer while operating in the **Speed Control** mode.

Note: The **ASD – Multicom Option Board** and the **HS35 Encoder** is required for system operation using the **PG** input speed control.

PG Input Speed Control Setup

Perform the following setup to allow the system to receive **Speed** control input at the **PG** input terminal:

- Program ⇒ Fundamental Parameters ⇒ Standard Mode Selection ⇒ Frequency Mode #1 ⇒ **Pulse Input Option**.
- Program ⇒ Fundamental Parameters ⇒ Standard Mode Selection ⇒ Command Mode ⇒ (any setting).
- Set **PG Speed Reference #1 (F234)** — the input pulse count rate that represents **PG Speed Frequency #1**.
- Set **PG Speed Frequency #1 (F235)**.
- Set **PG Speed Reference #2 (F236)** — the input pulse count rate that represents **PG Speed Frequency #2**.
- Set **PG Speed Frequency #2 (F237)**.
- Provide a **Run** command (**F** and/or **R**).

Once set, as the **PG** pulse count rate changes, the output frequency of the ASD will vary in accordance with the above settings.

This parameter sets **PG Speed Reference #1** and is the input pulse count rate that is associated with the setting of **PG Speed Frequency #1** while operating in the **Speed Control** mode.

Direct Access Number — F234

Parameter Type — Numerical

Factory Default — 0.00

Changeable During Run — Yes

Minimum — -100.0

Maximum — 100.0

Units — %

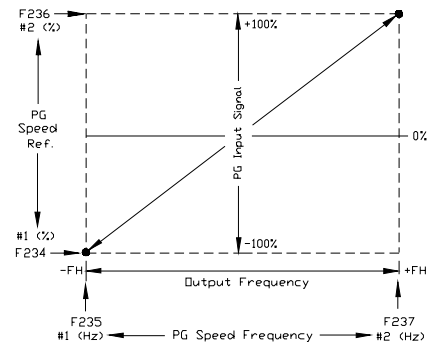
Frequency Settings

<p>PG Speed Frequency #1</p> <p>Program ⇒ Frequency Setting Parameters ⇒ Speed Reference Setpoints ⇒ PG</p> <p>This parameter is used to set the gain and bias of the PG input terminal when a shaft-mounted encoder is used as the feedback transducer while operating in the Speed Control mode.</p> <p>See PG Speed Reference #1 (F234) for further information on this setting.</p> <p>This parameter sets PG Speed Frequency #1 and is the frequency that is associated with the setting of PG Speed Reference #1 while operating in the Speed Control mode.</p>	<p>Direct Access Number — F235</p> <p>Parameter Type — Numerical</p> <p>Factory Default — 0.00</p> <p>Changeable During Run — Yes</p> <p>Minimum — -Max. Freq. (F011)</p> <p>Maximum — Max. Freq. (F011)</p> <p>Units — Hz</p>
<p>PG Speed Reference #2</p> <p>Program ⇒ Frequency Setting Parameters ⇒ Speed Reference Setpoints ⇒ PG</p> <p>This parameter is used to set the gain and bias of the PG input terminal when a shaft-mounted encoder is used as the feedback transducer while operating in the Speed Control mode.</p> <p>See PG Speed Reference #1 for further information on this setting when used for Speed control.</p> <p>This parameter sets the PG input level that is associated with PG Speed Frequency #2 while operating in the Speed control mode.</p>	<p>Direct Access Number — F236</p> <p>Parameter Type — Numerical</p> <p>Factory Default — 100.00</p> <p>Changeable During Run — Yes</p> <p>Minimum — -100.0</p> <p>Maximum — 100.0</p> <p>Units — %</p>
<p>PG Speed Frequency #2</p> <p>Program ⇒ Frequency Setting Parameters ⇒ Speed Reference Setpoints ⇒ PG</p> <p>This parameter is used to set the gain and bias of the PG input terminal when a shaft-mounted encoder is used as the feedback transducer while operating in the Speed Control mode.</p> <p>See PG Speed Reference #1 for further information on this setting when used for Speed control.</p> <p>This parameter sets PG Speed Frequency #2 and is the frequency that is associated with the setting of PG Speed Reference #2 while operating in the Speed Control mode.</p>	<p>Direct Access Number — F237</p> <p>Parameter Type — Numerical</p> <p>Factory Default — 80.00</p> <p>Changeable During Run — Yes</p> <p>Minimum — -Max. Freq. (F011)</p> <p>Maximum — Max. Freq. (F011)</p> <p>Units — Hz</p>
<p>Startup Frequency</p> <p>Program ⇒ Special Control Parameters ⇒ Frequency Control</p> <p>The output of the drive will remain at 0.0 Hz until the programmed speed value exceeds this setting during startup. Once exceeded during startup, the output frequency of the drive will accelerate to the programmed setting.</p> <p>Output frequencies below the Startup Frequency will not be output from the drive during startup. However, once reaching the Startup Frequency, speed values below the Startup Frequency may be output from the drive.</p>	<p>Direct Access Number — F240</p> <p>Parameter Type — Numerical</p> <p>Factory Default — 0.10</p> <p>Changeable During Run — Yes</p> <p>Minimum — 0.0</p> <p>Maximum — 10.0</p> <p>Units — Hz</p>

<p>Run Frequency</p> <p>Program ⇒ Special Control Parameters ⇒ Frequency Control</p> <p>This parameter establishes a center frequency (Run Frequency) of a frequency band.</p> <p>Parameter F242 provides a plus-or-minus value for the Run Frequency; thus, establishing a frequency band.</p> <p>During acceleration, the drive will not output a signal to the motor until the lower level of the band is reached.</p> <p>During deceleration, the drive will continue to output the programmed deceleration output signal to the motor until the lower level of the band is reached; at which time the output will go to 0.0 Hz.</p>	<p>Direct Access Number — F241</p> <p>Parameter Type — Numerical</p> <p>Factory Default — 0.0</p> <p>Changeable During Run — Yes</p> <p>Minimum — 0.0</p> <p>Maximum — Max. Freq. (F011)</p> <p>Units — Hz</p>
<p>Run Frequency Hysteresis</p> <p>Program ⇒ Special Control Parameters ⇒ Frequency Control</p> <p>This parameter provides a plus-or-minus value for the Run Frequency setting (F241).</p>	<p>Direct Access Number — F242</p> <p>Parameter Type — Numerical</p> <p>Factory Default — 0.0</p> <p>Changeable During Run — Yes</p> <p>Minimum — 0.0</p> <p>Maximum — 30.0</p> <p>Units — Hz</p>
<p>End Frequency</p> <p>Program ⇒ Special Control Parameters ⇒ Frequency Control</p> <p>This parameter sets the lowest frequency that the drive will recognize during deceleration before the drive goes to 0.0 Hz.</p>	<p>Direct Access Number — F243</p> <p>Parameter Type — Numerical</p> <p>Factory Default — 0.0</p> <p>Changeable During Run — Yes</p> <p>Minimum — 0.0</p> <p>Maximum — 30.0</p> <p>Units — Hz</p>
<p>0 Hz Dead Band Signal</p> <p>Program ⇒ Special Control Parameters ⇒ Special Parameters ⇒ Dead Band of 0 Hz Frequency</p> <p>This parameter sets an output frequency threshold that, until the commanded frequency surpasses this setting, the ASD will output 0 Hz to the motor.</p> <p><i>Note: This setting will override the Startup Frequency setting (F240) if this setting has a higher value.</i></p>	<p>Direct Access Number — F244</p> <p>Parameter Type — Numerical</p> <p>Factory Default — 0.0</p> <p>Changeable During Run — Yes</p> <p>Minimum — 0.0</p> <p>Maximum — 5.0</p> <p>Units — Hz</p>

DC Injection Braking Start FrequencyProgram ⇒ Protection Parameters ⇒ **DC Braking**

During deceleration this is the frequency at which **DC Injection** braking will start.

DC Injection Braking

DC Injection Braking is a braking system used with three-phase motors. Unlike conventional brakes, there is no physical contact between the rotating shaft and a stationary brake pad or drum. When braking is required, the drive outputs a DC current that is applied to the windings of the motor to quickly brake the motor. The braking current stops when the time entered in **F252** times out.

The intensity of the DC current used while braking determines how fast the motor will come to a stop and may be set at **F251**. The intensity setting is entered as a percentage of the full load current of the ASD.

DC Injection Braking is also used to preheat the motor or to keep the rotor from spinning freely when the motor is off by providing a pulsating DC current into the motor at the **Carrier Frequency**. This feature may be enabled at **F254**.

Direct Access Number — F250Parameter Type — **Numerical**Factory Default — **0.0**Changeable During Run — **Yes**

Minimum — 0.0

Maximum — 120.0

Units — Hz

DC Injection Braking CurrentProgram ⇒ Protection Parameters ⇒ **DC Braking**

This parameter sets the percentage of the rated current of the drive that will be used for **DC Injection** braking. A larger load will require a higher setting.

Direct Access Number — F251Parameter Type — **Numerical**Factory Default — **50.00**Changeable During Run — **Yes**

Minimum — 0.00

Maximum — 100.0

Units — %

DC Injection Braking TimeProgram ⇒ Protection Parameters ⇒ **DC Braking**

This parameter is used to set the on-time duration of the **DC Injection Braking**.

Direct Access Number — F252Parameter Type — **Numerical**Factory Default — **1.00**Changeable During Run — **Yes**

Minimum — 0.00

Maximum — 10.00

Units — Seconds

Motor Shaft Fixing ControlProgram ⇒ Protection Parameters ⇒ **DC Braking**

This parameter determines if **DC Injection** braking is to be used during a change in the direction of the motor.

Settings:

Box checked (Enabled)

Box not checked (Disabled)

Direct Access Number — F253Parameter Type — **Check Box**Factory Default — **Disabled**Changeable During Run — **Yes**

F254

F255

Motor Shaft Stationary ControlProgram ⇒ Protection Parameters ⇒ **DC Braking**

This parameter **Enables/Disables** a continuous DC injection at half of the amperage setting of **F251** into a stopped motor. This feature is useful in preheating the motor or to keep the rotor from spinning freely.

Motor Shaft Stationary Control starts after the DC injection brake stops the motor and continues until **ST – CC** is opened, power is turned off, receiving an **Emergency Off** command, or this parameter is changed.

Enabling this feature will also require a non-zero entry at **F250**.

Settings:

Box checked (Enabled)

Box not checked (Disabled)

0 Hz Command FunctionProgram ⇒ Special Control Parameters ⇒ Special Parameters ⇒ **Dead Band of 0 Hz Frequency**

This parameter selects the go-to-zero method to be used by the ASD when the ASD is commanded to go to zero Hz.

Settings:

Standard (DC Injection Braking)

0 Hz Command

Direct Access Number — F254Parameter Type — **Check Box**Factory Default — **Disabled**Changeable During Run — **Yes**

Direct Access Number — F255Parameter Type — **Selection List**Factory Default — **Standard (DC Injection Braking)**Changeable During Run — **No**

Jog Run Frequency

Program ⇒ Frequency Setting Parameters ⇒ **Jog Settings**

This parameter sets the output frequency of the drive during a **Jog**. **Jogging** is the term used to describe turning the motor on for small increments of time and is used when precise positioning of motor-driven equipment is required.

Enabling the **Jog Window** allows for the **Manual Jog** window to be among the screens accessed during repeated **MON/PRG** entries. This screen must be displayed when **Jogging** using the **EOI**.

The **Jog** function may be initiated from the **EOI** or remotely via the **Control Terminal Strip** or using **Communications** (for further information on using **Communications** for **Jogging**, see the **Communications** manual).

To perform a **Jog**, set this parameter (**F260**) to the desired **Jog** frequency.

Select a **Jog Stop** method (**F261**).

Jog Setup Using the EOI

To initiate a **Jog** from the **EOI** perform the following:

1. Place a check in the **Enable Jog Window** box (Program ⇒ Frequency Setting Parameters ⇒ Jog Settings ⇒ **Enable Jog Window**).

Note: The **Jog Window** must be displayed on the **EOI** to perform the **Jog** function using the **EOI**.

2. Press **MON/PRG** to access the **Jog Window**.
3. Using the **Up/Down** arrow keys of the **EOI**, select **Reverse** or **Forward**.
4. Place the system in the **Local** mode (**Local/Remote** LED is on).
5. Press and hold the **Run** key for the desired **Jog** duration.

Jog Setup Using the Control Terminal Strip

To initiate a **Jog** from the **Control Terminal Strip** perform the following:

1. Assign a discrete input terminal to the **Jog** function (see [Table 8 on pg. 77](#)).
2. Assign a discrete input terminal to the **F (Forward)** function (and **Reverse** if required) (see [Table 8 on pg. 77](#)).
3. Provide a **Forward** and/or **Reverse** command from the **Control Terminal Strip**.
4. From the **Jog Window**, use the **Up/Down** arrow keys of the **EOI** to select **Reverse** or **Forward** (Program ⇒ Frequency Setting Parameters ⇒ Jog Settings ⇒ **Enable Jog Window**). Press **MON/PRG** to access the **Jog Window**.
5. Place the system in the **Remote** mode (**Local/Remote** LED is off).
6. Connect the assigned **Jog** terminal (from step 1) to **CC** for the desired **Jog** duration.

Direct Access Number — **F260**

Parameter Type — **Numerical**

Factory Default — **0.00**

Changeable During Run — **Yes**

Minimum — 0.00

Maximum — 20.00

Units — Hz

<p>Jog Stop Control</p> <p>Program ⇒ Frequency Setting Parameters ⇒ Jog Settings</p> <p>This parameter sets the stopping method used while operating in the Jog mode.</p> <p>Settings:</p> <ul style="list-style-type: none"> Deceleration Stop Coast Stop DC Injection Braking Stop 	<p>Direct Access Number — F261</p> <p>Parameter Type — Selection List</p> <p>Factory Default — Deceleration Stop</p> <p>Changeable During Run — Yes</p>
<p>Jump Frequency #1</p> <p>Program ⇒ Special Control Parameters ⇒ Jump Frequencies</p> <p>In conjunction with parameter F271, this parameter establishes a user-defined frequency range: the Jump Frequency and a plus-or-minus value. During acceleration, the output frequency of the drive will hold at the frequency of the lower level of the Jump Frequency range until the programmed acceleration ramp reaches the upper level of the Jump Frequency range. Then, the output frequency of the drive will accelerate to the upper level of the Jump Frequency range and continue upward as programmed.</p> <p>During deceleration, the output frequency of the drive will hold at the frequency of the upper level of the Jump Frequency range until the programmed deceleration ramp reaches the lower level of the Jump Frequency range. Then, the output frequency of the drive will decelerate to the lower level of the Jump Frequency range and continue downward as programmed.</p> <p>Once set up and enabled, it is on in all control modes.</p> <p>User-selected frequencies may be jumped to avoid the negative effects of mechanical resonance.</p>	<p>Direct Access Number — F270</p> <p>Parameter Type — Numerical</p> <p>Factory Default — 0.00</p> <p>Changeable During Run — Yes</p> <p>Minimum — 0.00</p> <p>Maximum — Max. Freq. (F011)</p> <p>Units — Hz</p>
<p>Jump Frequency #1 Bandwidth</p> <p>Program ⇒ Special Control Parameters ⇒ Jump Frequencies</p> <p>This parameter establishes a plus-or-minus value for Jump Frequency #1 (see F270).</p>	<p>Direct Access Number — F271</p> <p>Parameter Type — Numerical</p> <p>Factory Default — 0.00</p> <p>Changeable During Run — Yes</p> <p>Minimum — 0.00</p> <p>Maximum — 30.00</p> <p>Units — Hz</p>
<p>Jump Frequency #2</p> <p>Program ⇒ Special Control Parameters ⇒ Jump Frequencies</p> <p>Same as Jump Frequency #1 (F270) and is used when multiple frequencies are to be jumped (see the plus-or-minus value setting at F273). When multiple jump frequencies overlap, the system will recognize the lowest and the highest frequencies as one jump range.</p>	<p>Direct Access Number — F272</p> <p>Parameter Type — Numerical</p> <p>Factory Default — 0.00</p> <p>Changeable During Run — Yes</p> <p>Minimum — 0.00</p> <p>Maximum — Max. Freq. (F011)</p> <p>Units — Hz</p>
<p>Jump Frequency #2 Bandwidth</p> <p>Program ⇒ Special Control Parameters ⇒ Jump Frequencies</p> <p>This parameter establishes a plus-or-minus value for Jump Frequency #2 (F272).</p>	<p>Direct Access Number — F273</p> <p>Parameter Type — Numerical</p> <p>Factory Default — 0.00</p> <p>Changeable During Run — Yes</p> <p>Minimum — 0.00</p> <p>Maximum — 30.0</p> <p>Units — Hz</p>

<p>Jump Frequency #3</p> <p>Program ⇒ Special Control Parameters ⇒ Jump Frequencies</p> <p>Same as Jump Frequency #1 (F270) and is used when multiple frequencies are to be jumped (see the plus-or-minus value setting at F275). When multiple jump frequencies overlap, the system will recognize the lowest and the highest frequencies as one jump range.</p>	<p>Direct Access Number — F274</p> <p>Parameter Type — Numerical</p> <p>Factory Default — 0.00</p> <p>Changeable During Run — Yes</p> <p>Minimum — 0.00</p> <p>Maximum — Max. Freq. (F011)</p> <p>Units — Hz</p>
<p>Jump Frequency #3 Bandwidth</p> <p>Program ⇒ Special Control Parameters ⇒ Jump Frequencies</p> <p>This parameter establishes a plus-or-minus value for Jump Frequency #3 (F274).</p>	<p>Direct Access Number — F275</p> <p>Parameter Type — Numerical</p> <p>Factory Default — 0.00</p> <p>Changeable During Run — Yes</p> <p>Minimum — 0.00</p> <p>Maximum — 30.0</p> <p>Units — Hz</p>
<p>Jump Frequency Processing</p> <p>Program ⇒ Special Control Parameters ⇒ Jump Frequencies ⇒ Jump Frequency Processing</p> <p>This parameter determines if the output frequency of the ASD or the PID feedback signal will be used as a reference for determining the Jump Frequency range.</p> <p>See F270 for further information on the Jump Frequency settings.</p> <p>Settings:</p> <ul style="list-style-type: none"> Process Amount (use PID feedback) Output Frequency 	<p>Direct Access Number — F276</p> <p>Parameter Type — Selection List</p> <p>Factory Default — Process Amount</p> <p>Changeable During Run — Yes</p>
<p>Preset Speed #8</p> <p>Program ⇒ Pattern Run Control ⇒ Preset Speeds ⇒ 8</p> <p>This parameter assigns an output frequency to binary number 1000 and is identified as Preset Speed #8. The binary number is applied to S1 – S4 of the Control Terminal Strip to output the Preset Speed (see F018 for further information on this parameter).</p>	<p>Direct Access Number — F287</p> <p>Parameter Type — Numerical</p> <p>Factory Default — 0.00</p> <p>Changeable During Run — Yes</p> <p>Minimum — Lower Limit (F013)</p> <p>Maximum — Upper Limit (F012)</p> <p>Units — Hz</p>
<p>Preset Speed #9</p> <p>Program ⇒ Pattern Run Control ⇒ Preset Speeds ⇒ 9</p> <p>This parameter assigns an output frequency to binary number 1001 and is identified as Preset Speed #9. The binary number is applied to S1 – S4 of the Control Terminal Strip to output the Preset Speed (see F018 for further information on this parameter).</p>	<p>Direct Access Number — F288</p> <p>Parameter Type — Numerical</p> <p>Factory Default — 0.0</p> <p>Changeable During Run — Yes</p> <p>Minimum — Lower Limit (F013)</p> <p>Maximum — Upper Limit (F012)</p> <p>Units — Hz</p>

<p>Preset Speed #10</p> <p>Program ⇒ Pattern Run Control ⇒ Preset Speeds ⇒ 10</p> <p>This parameter assigns an output frequency to binary number 1010 and is identified as Preset Speed #10. The binary number is applied to S1 – S4 of the Control Terminal Strip to output the Preset Speed (see F018 for further information on this parameter).</p>	<p>Direct Access Number — F289</p> <p>Parameter Type — Numerical</p> <p>Factory Default — 0.00</p> <p>Changeable During Run — Yes</p> <p>Minimum — Lower Limit (F013)</p> <p>Maximum — Upper Limit (F012)</p> <p>Units — Hz</p>
<p>Preset Speed #11</p> <p>Program ⇒ Pattern Run Control ⇒ Preset Speeds ⇒ 11</p> <p>This parameter assigns an output frequency to binary number 1011 and is identified as Preset Speed #11. The binary number is applied to S1 – S4 of the Control Terminal Strip to output the Preset Speed (see F018 for further information on this parameter).</p>	<p>Direct Access Number — F290</p> <p>Parameter Type — Numerical</p> <p>Factory Default — 0.00</p> <p>Changeable During Run — Yes</p> <p>Minimum — Lower Limit (F013)</p> <p>Maximum — Upper Limit (F012)</p> <p>Units — Hz</p>
<p>Preset Speed #12</p> <p>Program ⇒ Pattern Run Control ⇒ Preset Speeds ⇒ 12</p> <p>This parameter assigns an output frequency to binary number 1100 and is identified as Preset Speed #12. The binary number is applied to S1 – S4 of the Control Terminal Strip to output the Preset Speed (see F018 for further information on this parameter).</p>	<p>Direct Access Number — F291</p> <p>Parameter Type — Numerical</p> <p>Factory Default — 0.00</p> <p>Changeable During Run — Yes</p> <p>Minimum — Lower Limit (F013)</p> <p>Maximum — Upper Limit (F012)</p> <p>Units — Hz</p>
<p>Preset Speed #13</p> <p>Program ⇒ Pattern Run Control ⇒ Preset Speeds ⇒ 13</p> <p>This parameter assigns an output frequency to binary number 1101 and is identified as Preset Speed #13. The binary number is applied to S1 – S4 of the Control Terminal Strip to output the Preset Speed (see F018 for further information on this parameter).</p>	<p>Direct Access Number — F292</p> <p>Parameter Type — Numerical</p> <p>Factory Default — 0.00</p> <p>Changeable During Run — Yes</p> <p>Minimum — Lower Limit (F013)</p> <p>Maximum — Upper Limit (F012)</p> <p>Units — Hz</p>
<p>Preset Speed #14</p> <p>Program ⇒ Pattern Run Control ⇒ Preset Speeds ⇒ 14</p> <p>This parameter assigns an output frequency to binary number 1110 and is identified as Preset Speed #14. The binary number is applied to S1 – S4 of the Control Terminal Strip to output the Preset Speed (see F018 for further information on this parameter).</p>	<p>Direct Access Number — F293</p> <p>Parameter Type — Numerical</p> <p>Factory Default — 0.00</p> <p>Changeable During Run — Yes</p> <p>Minimum — Lower Limit (F013)</p> <p>Maximum — Upper Limit (F012)</p> <p>Units — Hz</p>
<p>Preset Speed #15</p> <p>Program ⇒ Pattern Run Control ⇒ Preset Speeds ⇒ 15</p> <p>This parameter assigns an output frequency to binary number 1111 and is identified as Preset Speed #15. The binary number is applied to S1 – S4 of the Control Terminal Strip to output the Preset Speed (see F018 for further information on this parameter).</p>	<p>Direct Access Number — F294</p> <p>Parameter Type — Numerical</p> <p>Factory Default — 0.00</p> <p>Changeable During Run — Yes</p> <p>Minimum — Lower Limit (F013)</p> <p>Maximum — Upper Limit (F012)</p> <p>Units — Hz</p>

PWM Carrier Frequency

Program ⇒ Special Control Parameters ⇒ **Carrier Frequency**

This parameter sets the frequency of the pulse width modulation signal applied to the motor.

Note: The carrier frequency must be 2.2 kHz or above except while operating in the **Constant Torque**, **Variable Torque**, or the **5-Point Setting** modes.

Note: The maximum **Carrier Frequency** setting allowed is 5.0 kHz for the following ASDs:

230-volt ⇒ 75 HP – 150 HP.

460-volt ⇒ 150 HP – 350 HP.

600-volt ⇒ 150 HP – 300 HP.

The maximum **Carrier Frequency** setting allowed for all other ASDs is 15 kHz.

Setting the Carrier Frequency above the Derate Threshold frequency (as listed below) for a given ASD will reduce the capability of the ASD.

Carrier-Frequency Derate Threshold Frequency

Derate Threshold Frequency			
2.2 kHz	5.0 kHz	6.0 kHz	8.0 kHz
V T 1 3 0 H 7 U			
2750B – 215KB	2500B	6160B	2010B – 2600B
2750B – 215KB	2600B	6400B	2400B
415KB – 435KB	4400B	6400B	4015B – 4330B
415KB – 435KB	412KB		4500B – 410KB
615KB – 635KB	410KB		4600B – 4750B
	412KB		6015B – 6120B
	610KB		6220B – 6330B
	610KB		6220B – 6330B
	612KB		6500B – 6750B
			6500B – 6750B

Direct Access Number — F300

Parameter Type — **Numerical**

Factory Default — **2.200**

Changeable During Run — **No**

Minimum — 0.500

Maximum — (ASD-dependent)

Units — kHz

Example

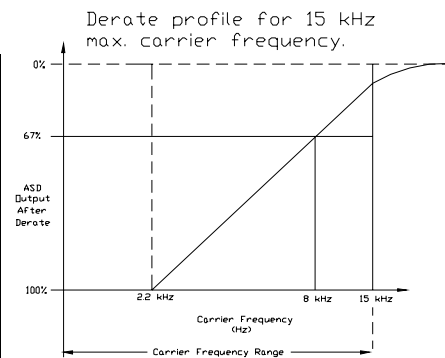

Break/Make ST

Program ⇒ Protection Parameters ⇒ **Retry/Restart**

This parameter **Enables/Disables** the ability of the drive to start into a spinning motor when the **ST – CC** connection opens momentarily and is then closed (Break/Make ST) or after a power interruption (momentary power failure). This parameter also **Enables/Disables** **F312** and **F313**.

Settings:

Box checked (Enabled)

Box not checked (Disabled)

Direct Access Number — F301

Parameter Type — **Check Box**

Factory Default — **Disabled**

Changeable During Run — **Yes**

Ridethrough ModeProgram ⇒ Protection Parameters ⇒ **Undervoltage/Ridethrough**

This parameter determines the motor-control response of the drive in the event of a momentary power outage.

Settings:

- Off
- Ridethrough
- Stop

Direct Access Number — F302Parameter Type — **Selection List**Factory Default — **Off**Changeable During Run — **Yes**

Number of RetriesProgram ⇒ Protection Parameters ⇒ **Retry/Restart**

After a trip has occurred, this parameter sets the number of times that an automatic system restart is attempted for a qualified trip.

The trip conditions listed below will not initiate the automatic **Retry/Restart** function:

- U, V, W phase short circuit,
- DBR Resistor Overcurrent,
- Input Phase Loss (Input Phase Failure),
- Output Phase Loss (Output Phase Failure),
- Overcurrent During Acceleration (Startup Overcurrent),
- Earth Fault (Ground Fault),
- EMG (Emergency Off),
- EEPROM Data Fault (EEPROM Fault),
- Flash Memory/Gate Array/RAM-ROM Fault,
- CPU Fault,
- Communication Error,
- Option Fault,
- Output Current Protection Fault,
- Sink/Source Setting Error,
- Overspeed Error, or
- Key Error.

See the section titled [General Safety Information on pg. 1](#) for further information on this setting.

Direct Access Number — F303Parameter Type — **Numerical**Factory Default — **00**Changeable During Run — **Yes**

Minimum — 00

Maximum — 10

Dynamic Braking EnableProgram ⇒ Protection Parameters ⇒ **Dynamic Braking**This parameter **Enables/Disables** the **Dynamic Braking** system.

Settings:

- Enabled with Overload
- Disabled

Dynamic Braking

Dynamic Braking uses the inertial energy of the load to produce a braking force or it may be used to reduce the bus voltage in an attempt to preclude an overvoltage trip during deceleration. The inertial energy of the load drives the rotor and induces a current into the stator of the motor.

The induced stator current (energy) is dissipated through a resistive load. The resistive load is connected across terminals **PA** and **PB** (non-polarized). Using a low-value, high-wattage resistance as a load for the generated current, the resistive load dissipates the induced energy. The dissipated energy is the energy that would otherwise have caused the rotor to continue to rotate.

Dynamic Braking helps to slow the load quickly; it cannot act as a holding brake.

The **Dynamic Braking** function may be setup and enabled by connecting a braking resistor from terminal **PA** to **PB** of the drive and providing the proper information at **F304**, **F308**, and **F309**.

For additional information on selecting the proper resistance value for a given application contact **Toshiba's Marketing Department**.

Direct Access Number — F304Parameter Type — **Selection List**Factory Default — **Disabled**Changeable During Run — **No**

Overvoltage StallProgram ⇒ Protection Parameters ⇒ **Stall**

This parameter **Enables/Disables** the **Overvoltage Stall** function. When enabled, this function causes the drive to extend the decel time when the DC bus voltage increases due to transient voltage spikes, regeneration, supply voltage out of specification, etc. in an attempt to reduce the bus voltage.

Settings:

- Enabled
- Disabled
- Enabled (Forced Shorted Deceleration)

Direct Access Number — F305Parameter Type — **Selection List**Factory Default — **Enabled**Changeable During Run — **Yes**

Motor #1 Max Output VoltageProgram ⇒ Motor Parameters ⇒ **Motor Set #1**

This parameter sets the maximum value of the output voltage of the drive. The **Motor #1 Maximum Output Voltage** is the **Motor #1** output voltage at the **Base Frequency (F014)**. Regardless of the programmed value, the output voltage cannot be higher than the input voltage.

The actual output voltage will be influenced by the input voltage of the ASD and the **Supply Voltage Compensation** setting (**F307**).

Direct Access Number — F306Parameter Type — **Numerical**

Factory Default — (ASD dependent)

Changeable During Run — **Yes**

Minimum — 0.0

Maximum — 600.0

Units — Volts

<p>Supply Voltage Compensation</p> <p>Program ⇒ Protection Parameters ⇒ Base Frequency Voltage</p> <p>This parameter Enables/Disables the Voltage Compensation function. This function provides an output waveform adjustment that compensates for changes in the input voltage.</p> <p>Settings:</p> <ul style="list-style-type: none"> Box checked (Enabled) Box not checked (Disabled) 	<p>Direct Access Number — F307</p> <p>Parameter Type — Check Box</p> <p>Factory Default — Enabled</p> <p>Changeable During Run — No</p>
<p>Dynamic Braking Resistance</p> <p>Program ⇒ Protection Parameters ⇒ Dynamic Braking</p> <p>This parameter is used to input the resistive value of the Dynamic Braking Resistor.</p> <p>For additional information on selecting the proper resistance value for a given application contact Toshiba's Marketing Department.</p> <p><i>Note:</i> Using a resistor value that is too low may result in system damage.</p>	<p>Direct Access Number — F308</p> <p>Parameter Type — Numerical</p> <p>Factory Default — (ASD-dependent)</p> <p>Changeable During Run — No</p> <p>Minimum — 1.0</p> <p>Maximum — 1000.0</p> <p>Units — Ω</p>
<p>Dynamic Braking Resistance Capacity</p> <p>Program ⇒ Protection Parameters ⇒ Dynamic Braking</p> <p>This parameter is used to input the wattage of the Dynamic Braking Resistor.</p> <p>For additional information on selecting the proper resistor wattage value for a given application contact Toshiba's Marketing Department.</p> <p><i>Note:</i> Using a resistor with a wattage rating that is too low may result in system damage.</p>	<p>Direct Access Number — F309</p> <p>Parameter Type — Numerical</p> <p>Factory Default — (ASD-dependent)</p> <p>Changeable During Run — No</p> <p>Minimum — 0.01</p> <p>Maximum — 600.0</p> <p>Units — kW</p>
<p>Ridethrough Time</p> <p>Program ⇒ Protection Parameters ⇒ Retry/Restart</p> <p>In the event of a momentary power outage, this parameter determines the length of the Ridethrough time. During a Ridethrough, regenerative energy is used to maintain the control circuitry settings; it is not used to drive the motor.</p> <p>The Ridethrough will be maintained for the number of seconds set using this parameter.</p> <p><i>Note:</i> The actual Ridethrough Time is load-dependent.</p>	<p>Direct Access Number — F310</p> <p>Parameter Type — Numerical</p> <p>Factory Default — 2.00</p> <p>Changeable During Run — Yes</p> <p>Minimum — 0.00</p> <p>Maximum — 320.0</p> <p>Units — Seconds</p>
<p>Disable Forward Run/Disable Reverse Run</p> <p>Program ⇒ Frequency Setting Parameters ⇒ Forward/Reverse Disable</p> <p>This parameter Enables/Disables the Forward Run or Reverse Run mode.</p> <p>If either direction is disabled (box checked), commands received for the disabled direction will not be recognized.</p> <p>If both directions are disabled (both boxes checked), the received direction command will determine the direction of the motor rotation.</p> <p>Settings:</p> <ul style="list-style-type: none"> Disabled Enabled 	<p>Direct Access Number — F311</p> <p>Parameter Type — Check Box</p> <p>Factory Default — Disabled</p> <p>Changeable During Run — No</p>

Scan RateProgram ⇒ Protection Parameters ⇒ **Retry/Restart**

In the event of a momentary power outage, the output signal of the drive will cease. Upon restoration of power, the drive will output a low-level signal that will be used to determine the rotation speed of the rotor.

The low-level signal will start scanning the motor at **FH** and decrease until it reaches 0.0 Hz or it matches the signal produced by the turning rotor. Once the rate of rotation is determined, the drive will provide the normal output to engage the motor from its present speed.

This parameter determines the rate at which the scanning signal goes from **FH** to 0.0 Hz. See **F301** for additional information on this parameter.

Direct Access Number — **F312**Parameter Type — **Numerical**Factory Default — **(ASD-dependent)**Changeable During Run — **No**

Minimum — 0.50

Maximum — 2.50

Lock-on RateProgram ⇒ Protection Parameters ⇒ **Retry/Restart**

After a momentary power outage, the ASD may have to startup into a spinning motor. The **Lock On Rate** is the difference between the time that the RPM of the motor is determined by the ASD and the time that the ASD outputs a drive signal to the motor.

See **F301** for additional information on this parameter.

Direct Access Number — **F313**Parameter Type — **Numerical**Factory Default — **(ASD-dependent)**Changeable During Run — **No**

Minimum — 0.50

Maximum — 2.50

Search MethodProgram ⇒ Protection Parameters ⇒ **Retry/Restart**

In the event of a momentary power outage, this parameter may be used to set the starting point (frequency) of the scanning signal that is used to determine the rotor speed or this parameter may be used to select the method used to search for the speed of the rotor. See **F301** and **F312** for additional information on this parameter.

Settings:

- Normal
- Start from 0.0 Hz
- Start from Running Frequency
- Option Board (ASD-SS)
- PG

Direct Access Number — **F314**Parameter Type — **Selection List**Factory Default — **Normal**Changeable During Run — **No**

Search InertiaProgram ⇒ Protection Parameters ⇒ **Retry/Restart**

After a momentary power loss or the momentary loss of the **ST-to-CC** connection, this parameter sets the time for the commanded torque to reach its programmed setting during the automatic restart. This function is in effect so long as the **Retry/Restart** feature is enabled at **F301**.

Settings:

- 0.5 Sec. (fast)
- 1.0 Sec. (standard)
- 1.5 Sec.
- 2.0 Sec.
- 2.5 Sec.
- 3.0 Sec.
- 3.5 Sec.
- 4.0 Sec.
- 4.5 Sec.
- 5.0 Sec. (slow)

Direct Access Number — **F315**Parameter Type — **Selection List**Factory Default — **1.0**Changeable During Run — **No**

Units — Seconds

Drooping GainProgram ⇒ Feedback Parameters ⇒ **Drooping Control**

This parameter sets the effective 100% output torque level while operating in the **Drooping Control** mode. This value is the upper torque limit of the motor being driven by a given ASD while operating in the **Drooping Control** mode.

Drooping

Drooping Control, also called **Load Share**, is used to share the load among two or more mechanically coupled motors. Unlike **Stall**, which reduces the output frequency in order to limit the load once the load reaches a preset level, **Drooping** can decrease or increase the V/f setting of a motor to maintain a balance between the output torque levels of mechanically coupled motors.

Because of variances in gearboxes, sheaves, belts, motors, and since the speed of the motor is constrained by the mechanical system, one motor may experience more load than its counterpart and may become overloaded.

Drooping Control allows the overloaded motor to slow down, thus shedding load and encouraging a lightly-loaded motor to pick up the slack. The goal of **Drooping Control** is to have the same torque ratios for mechanically coupled motors.

Speed at Drooping Gain 0%Program ⇒ Feedback Parameters ⇒ **Drooping Control**

This parameter sets the motor speed when at the 0% output torque gain while operating in the **Drooping Control** mode. This function determines the lowest speed that **Drooping** will be in effect for motors that share the same load.

Speed at Drooping Gain 100%Program ⇒ Feedback Parameters ⇒ **Drooping Control**

This parameter sets the motor speed when at the 100% output torque gain while operating in the **Drooping Control** mode. This function determines the speed of the individual motors at the 100% **Drooping Gain** setting for motors that share the same load.

Drooping Insensitive Torque RangeProgram ⇒ Feedback Parameters ⇒ **Drooping Control**

This parameter defines a torque range in which the **Drooping Control** settings will be ignored and the programmed torque settings will be followed.

Drooping Output FilterProgram ⇒ Feedback Parameters ⇒ **Drooping Control**

This parameter is used to set the rate of output change allowed while operating in the **Drooping Control** mode.

Jerky operation may be decreased by increasing this setting.

Direct Access Number — F320Parameter Type — **Numerical**Factory Default — **0.00**Changeable During Run — **Yes**

Minimum — 0.00

Maximum — 100.0

Units — %

Direct Access Number — F321Parameter Type — **Numerical**Factory Default — **60.00**Changeable During Run — **Yes**

Minimum — 0.00

Maximum — 320.0

Units — Hz

Direct Access Number — F322Parameter Type — **Numerical**Factory Default — **60.00**Changeable During Run — **Yes**

Minimum — 0.00

Maximum — 320.0

Units — Hz

Direct Access Number — F323Parameter Type — **Numerical**Factory Default — **10.00**Changeable During Run — **Yes**

Minimum — 0.00

Maximum — 100.0

Units — %

Direct Access Number — F324Parameter Type — **Numerical**Factory Default — **100.0**Changeable During Run — **Yes**

Minimum — 0.1

Maximum — 200.0

<p>Load Inertia (Acc/Dec Torque)</p> <p>Program ⇒ Feedback Parameters ⇒ Drooping Control ⇒ Load Inertia</p> <p>This parameter is used for calculating accel/decel torque when compensating for load inertia while operating in the Drooping Control mode.</p>	<p>Direct Access Number — F325</p> <p>Parameter Type — Numerical</p> <p>Factory Default — 1.0</p> <p>Changeable During Run — Yes</p> <p>Minimum — 0.0</p> <p>Maximum — 1000.0</p>
<p>Load Torque Filter (Acc/Dec Torque)</p> <p>Program ⇒ Feedback Parameters ⇒ Drooping Control ⇒ Load Inertia</p> <p>This parameter is used to set the response sensitivity when calculating the accel/decel torque. This setting applies to load inertia compensation while operating in the Drooping Control mode.</p> <p>This parameter should be gradually adjusted to provide smoother Drooping Control operation while operating with heavy loads.</p>	<p>Direct Access Number — F326</p> <p>Parameter Type — Numerical</p> <p>Factory Default — 200.0</p> <p>Changeable During Run — Yes</p> <p>Minimum — 0.0</p> <p>Maximum — 200.0</p>
<p>Drooping Reference</p> <p>Program ⇒ Feedback Parameters ⇒ Drooping Control ⇒ Drooping Reference</p> <p>This parameter sets the method to be used in determining the output torque while operating in the Drooping Control mode.</p> <p>Settings:</p> <ul style="list-style-type: none"> Total Torque Calculated by the Detection Current. Torque without Acc/Dec Torque Calculated by Detection Current. Total Torque Calculated by the Command Current. Torque without Acc/Dec Torque Calculated by the Command Current. 	<p>Direct Access Number — F327</p> <p>Parameter Type — Selection List</p> <p>Factory Default — Total torque calculated by the detection current</p> <p>Changeable During Run — Yes</p>
<p>Light-load High-speed Operation Selection</p> <p>Program ⇒ Special Control Parameters ⇒ Crane/Hoist Settings ⇒ Express Speed Settings ⇒ Light-Load High-Speed Operation</p> <p>This parameter enables the Light-Load High-Speed function by selecting an operating mode. The Light-Load High-Speed function accelerates the output frequency of the ASD from the programmed speed to the setting established in F341.</p> <p>This parameter may be disabled.</p> <p>If either of the other selections are made and configured, and after the criteria of F331 – F333 are met, the Light-Load High-Speed function is enabled and this parameter determines the operating mode of the Light-Load High-Speed function.</p> <p>Settings:</p> <ul style="list-style-type: none"> Disabled Reserved Automatic Enable - Automatic Speed (F341) Automatic Enable - Preset Speed (Preset ID_{Bin} is OR'ed w/1000_{Bin}) Discrete Enable - Automatic Speed (F341) (see item 60 of Table 8 on pg. 77) Discrete Enable - Preset Speed (Preset ID_{Bin} is OR'ed w/1000_{Bin}) (see item 60 of Table 8 on pg. 77) 	<p>Direct Access Number — F330</p> <p>Parameter Type — Selection List</p> <p>Factory Default — Disabled</p> <p>Changeable During Run — No</p> <p>Minimum — 30.0</p> <p>Maximum — Upper Limit (F012)</p> <p>Units — Hz</p>

<p>Light-Load High-Speed Operation Switching Lower-Limit Frequency</p> <p>Program ⇒ Special Control Parameters ⇒ Crane/Hoist Settings ⇒ Express Speed Settings ⇒ Light-Load High-Speed Operation Switching Lower-Limit Frequency</p> <p>This parameter sets an output frequency threshold that, once surpassed, allows the Light-load High-speed function to be used.</p> <p>The Light-Load High-Speed function may be used if the frequency threshold (F331) and the following conditions are met:</p> <ol style="list-style-type: none"> 1) Light-Load High-Speed Operation Enable is configured at F330. 2) The output torque is less than the setting established in F335 when reaching the frequency setting here. 	<p>Direct Access Number — F331</p> <p>Parameter Type — Numerical</p> <p>Factory Default — 40.00</p> <p>Changeable During Run — Yes</p> <p>Minimum — 30.0</p> <p>Maximum — Upper Limit (F012)</p> <p>Units — Hz</p>
<p>Light-Load High-Speed Operation Load Wait Time</p> <p>Program ⇒ Special Control Parameters ⇒ Crane/Hoist Settings ⇒ Express Speed Settings ⇒ Light-Load High-Speed Operation Load Wait-Time</p> <p>After the time setting of F333 times out, this parameter determines the length of time that the Light-Load High-Speed criteria must be met until the Light-Load High-Speed function engages.</p>	<p>Direct Access Number — F332</p> <p>Parameter Type — Numerical</p> <p>Factory Default — 1.0</p> <p>Changeable During Run — Yes</p> <p>Minimum — 0.0</p> <p>Maximum — 10.0</p> <p>Units — Seconds</p>
<p>Light-Load High-Speed Operation Load Detection Time</p> <p>Program ⇒ Special Control Parameters ⇒ Crane/Hoist Settings ⇒ Express Speed Settings ⇒ Light-Load High-Speed Operation Load Detection Time</p> <p>This parameter determines the length of time that the load requirement must meet the Light-Load High-Speed criteria before the Light-Load High-Speed Enable (F330) is recognized.</p> <p>Once recognized, the timer setting of F332 must expire to engage the Light-Load High-Speed function.</p>	<p>Direct Access Number — F333</p> <p>Parameter Type — Yes</p> <p>Factory Default — 1.0</p> <p>Changeable During Run — Numerical</p> <p>Minimum — 0.0</p> <p>Maximum — 10.0</p> <p>Units — Seconds</p>
<p>Light-Load High-Speed Operation Heavy-Load Detection Time</p> <p>Program ⇒ Special Control Parameters ⇒ Crane/Hoist Settings ⇒ Express Speed Settings ⇒ Light-Load High-Speed Operation Heavy-Load Detection Time</p> <p>While operating in the Light-Load High-Speed mode, this parameter determines the length of time that a load exceeding the Light-Load High-Speed operation criteria may exist before the Light-Load High-Speed mode is terminated and normal operation resumes.</p>	<p>Direct Access Number — F334</p> <p>Parameter Type — Numerical</p> <p>Factory Default — 5.0</p> <p>Changeable During Run — Yes</p> <p>Minimum — 0.0</p> <p>Maximum — 10.0</p> <p>Units — Seconds</p>

<p>Switching Load Torque During Forward-Run</p> <p>Program ⇒ Special Control Parameters ⇒ Crane/Hoist Settings ⇒ Express Speed Settings ⇒ Switching Load Torque During Forward Run</p> <p>While running forward, this parameter establishes the threshold torque level that is used to determine if the Light-Load High-Speed (F331) operation may engage or remain engaged if active.</p> <p>If the Light-Load High-Speed operation is terminated normal operation resumes.</p>	<p>Direct Access Number — F335</p> <p>Parameter Type — Numerical</p> <p>Factory Default — 50</p> <p>Changeable During Run — No</p> <p>Minimum — 0</p> <p>Maximum — 250</p> <p>Units — %</p>
<p>Heavy-Load Torque During Forward Acceleration</p> <p>Program ⇒ Special Control Parameters ⇒ Crane/Hoist Settings ⇒ Express Speed Settings ⇒ Heavy-Load Torque During Forward Acceleration</p> <p>During forward acceleration, this parameter establishes the threshold torque level that is used to determine if the Light-Load High-Speed (F331) operation may engage or remain engaged if active.</p> <p>If the Light-Load High-Speed operation is terminated normal operation resumes.</p>	<p>Direct Access Number — F336</p> <p>Parameter Type — Numerical</p> <p>Factory Default — 150</p> <p>Changeable During Run — Yes</p> <p>Minimum — 0</p> <p>Maximum — 250</p> <p>Units — %</p>
<p>Heavy-Load Torque During Forward Deceleration</p> <p>Program ⇒ Special Control Parameters ⇒ Crane/Hoist Settings ⇒ Express Speed Settings ⇒ Heavy-Load Torque During Forward Deceleration</p> <p>During forward deceleration, this parameter establishes the threshold torque level that is used to determine if the Light-Load High-Speed (F331) operation may engage or remain engaged if active.</p> <p>If the Light-Load High-Speed operation is terminated normal operation resumes.</p>	<p>Direct Access Number — F337</p> <p>Parameter Type — Numerical</p> <p>Factory Default — 100</p> <p>Changeable During Run — Yes</p> <p>Minimum — 0</p> <p>Maximum — 250</p> <p>Units — %</p>
<p>Switching Load Torque During Reverse-Run</p> <p>Program ⇒ Special Control Parameters ⇒ Crane/Hoist Settings ⇒ Express Speed Settings ⇒ Switching Load Torque During Reverse Run</p> <p>While running in reverse, this parameter establishes the threshold torque level that is used to determine if the Light-Load High-Speed (F331) operation may engage or remain engaged if active.</p> <p>If the Light-Load High-Speed operation is terminated normal operation resumes.</p>	<p>Direct Access Number — F338</p> <p>Parameter Type — Numerical</p> <p>Factory Default — 50</p> <p>Changeable During Run — Yes</p> <p>Minimum — 0</p> <p>Maximum — 250</p> <p>Units — %</p>
<p>Heavy-Load Torque During Reverse Acceleration</p> <p>Program ⇒ Special Control Parameters ⇒ Crane/Hoist Settings ⇒ Express Speed Settings ⇒ Heavy-Load Torque During Reverse Acceleration</p> <p>During reverse acceleration, this parameter establishes the threshold torque level that is used to determine if the Light-Load High-Speed (F331) operation may engage or remain engaged if active.</p> <p>If the Light-Load High-Speed operation is terminated normal operation resumes.</p>	<p>Direct Access Number — F339</p> <p>Parameter Type — Numerical</p> <p>Factory Default — 150</p> <p>Changeable During Run — Yes</p> <p>Minimum — 0</p> <p>Maximum — 250</p> <p>Units — %</p>

<p>Heavy-Load Torque During Reverse Deceleration</p> <p>Program ⇒ Special Control Parameters ⇒ Crane/Hoist Settings ⇒ Express Speed Settings ⇒ Heavy-Load Torque During Reverse Deceleration</p> <p>During reverse deceleration, this parameter establishes the threshold torque level that is used to determine if the Light-Load High-Speed (F331) operation may engage or remain engaged if active.</p> <p>If the Light-Load High-Speed operation is terminated normal operation resumes.</p>	<p>Direct Access Number — F340</p> <p>Parameter Type — Numerical</p> <p>Factory Default — 100</p> <p>Changeable During Run — Yes</p> <p>Minimum — 0</p> <p>Maximum — 250</p> <p>Units — %</p>
<p>Frequency for Automatic High-Speed Operation at Light-Load</p> <p>Program ⇒ Special Control Parameters ⇒ Crane/Hoist Settings ⇒ Express Speed Settings ⇒ Frequency for Automatic High-Speed Operation at Light-Load</p> <p>This parameter establishes the speed that the ASD will ramp to when operating in the Light-Load High-Speed mode.</p>	<p>Direct Access Number — F341</p> <p>Parameter Type — Numerical</p> <p>Factory Default — 80</p> <p>Changeable During Run — Yes</p> <p>Minimum — 0.00</p> <p>Maximum — 80.00</p> <p>Units — %</p>
<p>On-Trip Powerline Switching</p> <p>Program ⇒ Terminal Selection Parameters ⇒ Line Power Switching</p> <p>This parameter Enables/Disables the On Trip Powerline Switching feature. When enabled, the system is instructed to discontinue using the output of the drive and to switch to the commercial power in the event of a trip.</p> <p>Settings:</p> <ul style="list-style-type: none"> Disabled Enabled (box checked) 	<p>Direct Access Number — F354</p> <p>Parameter Type — Check Box</p> <p>Factory Default — Disabled</p> <p>Changeable During Run — No</p>
<p>At-Frequency Powerline Switching</p> <p>Program ⇒ Terminal Selection Parameters ⇒ Line Power Switching</p> <p>When enabled, this parameter sets the frequency at which the At Frequency Powerline Switching function engages. The At Frequency Powerline Switching function commands the system to discontinue using the output of the drive and to switch to commercial power once reaching the frequency set here.</p>	<p>Direct Access Number — F355</p> <p>Parameter Type — Numerical</p> <p>Factory Default — 60.00</p> <p>Changeable During Run — Yes</p> <p>Minimum — 0.00</p> <p>Maximum — Max. Freq. (F011)</p> <p>Units — Hz</p>

F356

F358

ASD-side Switching Wait TimeProgram ⇒ Terminal Selection Parameters ⇒ **Line Power Switching**

This parameter determines the amount of time that the drive will wait before outputting a signal to the motor once the switch-to-drive-output criteria has been met.

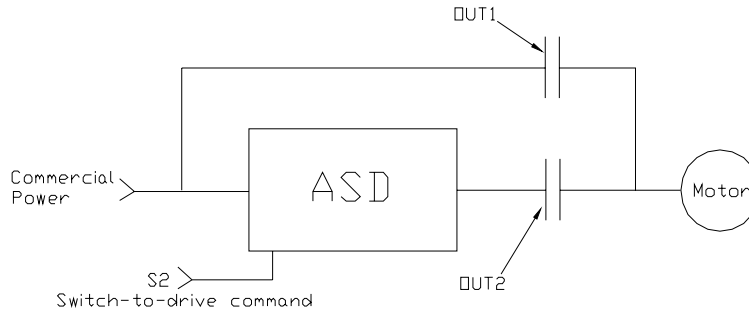
**Direct Access Number — F356**Parameter Type — **Numerical**Factory Default — **(ASD-dependent)**Changeable During Run — **Yes**

Minimum — 0.01

Maximum — 10.00

Units — Seconds

Commercial Power Wait TimeProgram ⇒ Terminal Selection Parameters ⇒ **Line Power Switching**

This parameter determines the amount of time that the drive will wait before allowing commercial power to be applied to the motor once the switch-to-commercial-power criteria has been met.

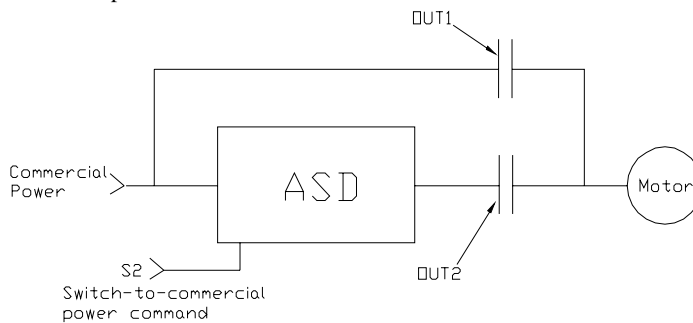
**Direct Access Number — F357**Parameter Type — **Numerical**Factory Default — **0.62**Changeable During Run — **Yes**

Minimum — (ASD-dependent)

Maximum — 10.00

Units — Seconds

Commercial Power Switching Freq. Hold TimeProgram ⇒ Terminal Selection Parameters ⇒ **Line Power Switching**

This parameter determines the amount of time that the connection to commercial power is maintained once the switch-to-drive-output criteria has been met.

Direct Access Number — F358Parameter Type — **Numerical**Factory Default — **2.00**Changeable During Run — **Yes**

Minimum — 0.10

Maximum — 10.00

Units — Seconds

Feedback SourceProgram ⇒ Feedback Parameters ⇒ **Feedback Settings**

This parameter **Enables/Disables PID** feedback control. When enabled, this parameter determines the source of the motor-control feedback.

Settings:

- PID Control Disabled
- VI/II
- RR
- RX
- RX2 (option)

Proportional-Integral-Derivative (PID) — A closed-loop control technique that seeks error minimization by reacting to three values: One that is proportional to the error, one that is representative of the error, and one that is representative of the rate of change of the error.

Feedback Source Delay FilterProgram ⇒ Feedback Parameters ⇒ **Feedback Settings**

This parameter determines the delay in the ASD output response to the motor-control feedback signal (signal source is selected at **F360**).

Proportional (P) GainProgram ⇒ Feedback Parameters ⇒ **Feedback Settings**

This parameter determines the degree that the **Proportional** function affects the output signal. The larger the value entered here, the quicker the drive responds to changes in feedback.

Integral (I) GainProgram ⇒ Feedback Parameters ⇒ **Feedback Settings**

This parameter determines the degree that the **Integral** function affects the output signal. The smaller the value here, the more pronounced the effect of the integral function on the output signal.

Upper Deviation LimitsProgram ⇒ Feedback Parameters ⇒ **Feedback Settings**

This parameter determines the maximum amount that the feedback may increase the output signal.

Direct Access Number — **F360**Parameter Type — **Selection List**Factory Default — **Control Disabled**Changeable During Run — **Yes**

Direct Access Number — **F361**Parameter Type — **Numerical**Factory Default — **0**Changeable During Run — **Yes**Minimum — **0**Maximum — **255**

Direct Access Number — **F362**Parameter Type — **Numerical**Factory Default — **0.10**Changeable During Run — **Yes**Minimum — **0.01**Maximum — **100.0**

Direct Access Number — **F363**Parameter Type — **Numerical**Factory Default — **0.10**Changeable During Run — **Yes**Minimum — **0.01**Maximum — **100.0**

Direct Access Number — **F364**Parameter Type — **Numerical**Factory Default — **50.00**Changeable During Run — **Yes**Minimum — **0.00**Maximum — **50.00**Units — **%**

<p>Lower Deviation Limits</p> <p>Program ⇒ Feedback Parameters ⇒ Feedback Settings</p> <p>This parameter determines the maximum amount that the feedback may decrease the output signal.</p>	<p>Direct Access Number — F365</p> <p>Parameter Type — Numerical</p> <p>Factory Default — 50.00</p> <p>Changeable During Run — Yes</p> <p>Minimum — 0.00</p> <p>Maximum — 50.00</p> <p>Units — %</p>
<p>Feedback Settings Differential (D) Gain</p> <p>Program ⇒ Feedback Parameters ⇒ Feedback Settings</p> <p>This parameter determines the degree that the Differential function affects the output signal. The larger the value entered here, the more pronounced the affect of the differential function for a given feedback signal level.</p>	<p>Direct Access Number — F366</p> <p>Parameter Type — Numerical</p> <p>Factory Default — 0.00</p> <p>Changeable During Run — Yes</p> <p>Minimum — 0.0</p> <p>Maximum — 2.55</p>
<p>Number of PG Input Pulses</p> <p>Program ⇒ Feedback Parameters ⇒ PG Settings</p> <p>This parameter is used to set the end-of-travel range when using an encoder on a motor-driven positioning system (e.g., hoist/crane, etc.).</p>	<p>Direct Access Number — F367</p> <p>Parameter Type — Numerical</p> <p>Factory Default — 500</p> <p>Changeable During Run — No</p> <p>Minimum — 1</p> <p>Maximum — 9999</p> <p>Units — Pulse Count</p>
<p>PG Input Phases</p> <p>Program ⇒ Feedback Parameters ⇒ PG Settings</p> <p>This parameter determines the type of information that is supplied by the phase encoder.</p> <p>Settings:</p> <ul style="list-style-type: none"> 1 — Speed 2 — Speed and Direction 	<p>Direct Access Number — F368</p> <p>Parameter Type — Selection List</p> <p>Factory Default — 2</p> <p>Changeable During Run — No</p> <p>Minimum — 1</p> <p>Maximum — 2</p> <p>Units — Phase Count</p>
<p>PG Disconnect Detection</p> <p>Program ⇒ Feedback Parameters ⇒ PG Settings</p> <p>This parameter Enables/Disables the system's monitoring of the PG connection status when using encoders with line driver outputs.</p> <p><i>Note: The ASD-Multicom-J option board is required to use this feature.</i></p> <p>Settings:</p> <ul style="list-style-type: none"> Disabled Enabled 	<p>Direct Access Number — F369</p> <p>Parameter Type — Selection List</p> <p>Factory Default — Disabled</p> <p>Changeable During Run — No</p>
<p>Electronic Gear Setting</p> <p>Program ⇒ Feedback Parameters ⇒ PG Settings</p> <p>This parameter sets the number of pulses per revolution when using a shaft-mounted encoder and the PG Option Board for closed loop speed control.</p>	<p>Direct Access Number — F370</p> <p>Parameter Type — Numerical</p> <p>Factory Default — 1000</p> <p>Changeable During Run — No</p> <p>Minimum — 100</p> <p>Maximum — 4000</p>

Position Loop GainProgram ⇒ Feedback Parameters ⇒ **PG Settings**

This parameter provides a divisor for the pulse input when operating in the **Pulse Control** mode.

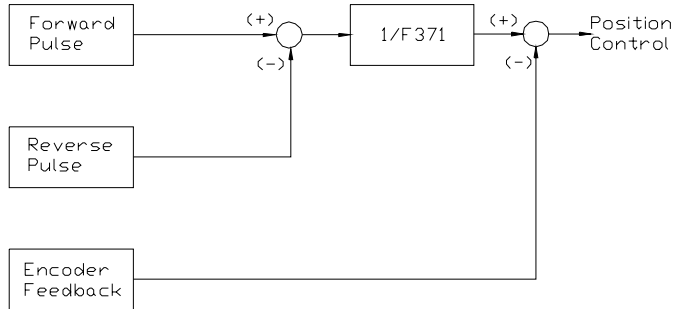
**Direct Access Number — F371**Parameter Type — **Numerical**Factory Default — **4.00**Changeable During Run — **Yes**

Minimum — 0.0

Maximum — 100.0

Position Completion RangeProgram ⇒ Feedback Parameters ⇒ **PG Settings**

During a deceleration ramp, this parameter sets a speed range that must be attained before the **Stop** command may be executed.

Direct Access Number — F372Parameter Type — **Numerical**Factory Default — **100**Changeable During Run — **Yes**

Minimum — 1

Maximum — 4000

Frequency Limit at PositionProgram ⇒ Feedback Parameters ⇒ **PG Settings**

While operating in the **Position-Control** mode and using **PG** feedback, this setting determines the maximum acceleration rate in Hz/second.

Direct Access Number — F373Parameter Type — **Numerical**Factory Default — **800**Changeable During Run — **Yes**

Minimum — 1

Maximum — 8001

Units — Hz/Second

Current Control Proportional GainProgram ⇒ Feedback Parameters ⇒ **PG Settings**

This parameter sets the sensitivity of the drive when monitoring the output current to control speed. The larger the value entered here, the more sensitive the drive is to changes in the received feedback.

Direct Access Number — F374Parameter Type — **Numerical**Factory Default — **(ASD-dependent)**Changeable During Run — **No**

Minimum — 100.0

Maximum — 1000

Current Control Integral GainProgram ⇒ Feedback Parameters ⇒ **PG Settings**

This parameter sets the degree and rate at which the output frequency will be allowed to change when prompted by changes in the output current.

The larger the value entered here, the quicker/more the drive responds to changes in feedback.

Direct Access Number — F375Parameter Type — **Numerical**Factory Default — **(ASD-dependent)**Changeable During Run — **No**

Minimum — 100.0

Maximum — 1250

Speed Loop Proportional GainProgram ⇒ Feedback Parameters ⇒ **PG Settings**

This parameter sets the **Proportional Gain** (sensitivity) of the drive when monitoring the **PG** signal to control speed. The larger the value entered here, the more sensitive the drive is to changes in the received feedback and the quicker it responds.

Direct Access Number — F376Parameter Type — **Numerical**Factory Default — **(ASD-dependent)**Changeable During Run — **Yes**

Minimum — 3.2

Maximum — 1000

Speed Loop Integral GainProgram ⇒ Feedback Parameters ⇒ **PG Settings**

This parameter sets the response time of the **Speed Loop Integral Gain**. The smaller the value here, the more pronounced (quicker) the effect of the integral function.

Direct Access Number — F377Parameter Type — **Numerical**Factory Default — **(ASD-dependent)**Changeable During Run — **Yes**

Minimum — 10.0

Maximum — 200.0

Motor Counter DataProgram ⇒ Feedback Parameters ⇒ **PG Settings**

This parameter sets the pulses-per-revolution displayed at the Monitor screen when using a shaft-mounted encoder for speed control. This setting is used for display purposes only and does not affect the speed control of the system.

If zero is selected here then the setting at [F370](#) (Electronic Gear Setting) determines the pulses-per-revolution to be displayed at the Monitor screen.

Direct Access Number — F378Parameter Type — **Selection List**Factory Default — **Selection 0**Changeable During Run — **No**

Minimum — Selection 0

Maximum — Selection 5

Settings:

Selection 0 — [F370](#) setting**Selection 1** — 256 pulses/revolution**Selection 2** — 512 pulses/revolution**Selection 3** — 1024 pulses/revolution**Selection 4** — 2048 pulses/revolution**Selection 5** — 4096 pulses/revolution

Speed Loop Parameter RatioProgram ⇒ Feedback Parameters ⇒ **PG Settings**

Contact Toshiba's Marketing Department for information on this parameter.

Direct Access Number — F379Parameter Type — **Numerical**Factory Default — **1.00**Changeable During Run — **No**

Minimum — 0.01

Maximum — 10.00

Use Speed ModeProgram ⇒ Pattern Run Control Parameters ⇒ **Preset Speed Mode**

This parameter **Enables/Disables** the **Use Speed** mode. When enabled, the system uses all of the parameter settings of the **Preset Speed** being run. Otherwise, only the frequency setting is used.

Direct Access Number — F380Parameter Type — **Check Box**Factory Default — **Disabled**Changeable During Run — **No**

Settings:

Disabled

Enabled (box checked)

F381

F386

<p>Preset Speed Direction #1</p> <p>Program ⇒ Pattern Run Control Parameters ⇒ Preset Speeds</p> <p>Determines the forward/reverse setting for the #1 Preset Speed (F018).</p> <p>Settings:</p> <ul style="list-style-type: none"> Forward Reverse 	<p>Direct Access Number — F381</p> <p>Parameter Type — Selection List</p> <p>Factory Default — Forward</p> <p>Changeable During Run — No</p>
<p>Preset Speed Direction #2</p> <p>Program ⇒ Pattern Run Control Parameters ⇒ Preset Speeds</p> <p>Determines the forward/reverse setting for the #2 Preset Speed (F019).</p> <p>Settings:</p> <ul style="list-style-type: none"> Forward Reverse 	<p>Direct Access Number — F382</p> <p>Parameter Type — Selection List</p> <p>Factory Default — Forward</p> <p>Changeable During Run — No</p>
<p>Preset Speed Direction #3</p> <p>Program ⇒ Pattern Run Control Parameters ⇒ Preset Speeds</p> <p>Determines the forward/reverse setting for the #3 Preset Speed (F020).</p> <p>Settings:</p> <ul style="list-style-type: none"> Forward Reverse 	<p>Direct Access Number — F383</p> <p>Parameter Type — Selection List</p> <p>Factory Default — Forward</p> <p>Changeable During Run — No</p>
<p>Preset Speed Direction #4</p> <p>Program ⇒ Pattern Run Control Parameters ⇒ Preset Speeds</p> <p>Determines the forward/reverse setting for the #4 Preset Speed (F021).</p> <p>Settings:</p> <ul style="list-style-type: none"> Forward Reverse 	<p>Direct Access Number — F384</p> <p>Parameter Type — Selection List</p> <p>Factory Default — Forward</p> <p>Changeable During Run — No</p>
<p>Preset Speed Direction #5</p> <p>Program ⇒ Pattern Run Control Parameters ⇒ Preset Speeds</p> <p>Determines the forward/reverse setting for the #5 Preset Speed (F022).</p> <p>Settings:</p> <ul style="list-style-type: none"> Forward Reverse 	<p>Direct Access Number — F385</p> <p>Parameter Type — Selection List</p> <p>Factory Default — Forward</p> <p>Changeable During Run — No</p>
<p>Preset Speed Direction #6</p> <p>Program ⇒ Pattern Run Control Parameters ⇒ Preset Speeds</p> <p>Determines the forward/reverse setting for the #6 Preset Speed (F023).</p> <p>Settings:</p> <ul style="list-style-type: none"> Forward Reverse 	<p>Direct Access Number — F386</p> <p>Parameter Type — Selection List</p> <p>Factory Default — Forward</p> <p>Changeable During Run — No</p>

<p>Preset Speed Direction #7</p> <p>Program ⇒ Pattern Run Control Parameters ⇒ Preset Speeds</p> <p>Determines the forward/reverse setting for the #7 Preset Speed (F024).</p> <p>Settings:</p> <ul style="list-style-type: none"> Forward Reverse 	<p>Direct Access Number — F387</p> <p>Parameter Type — Selection List</p> <p>Factory Default — Forward</p> <p>Changeable During Run — No</p>
<p>Preset Speed Direction #8</p> <p>Program ⇒ Pattern Run Control Parameters ⇒ Preset Speeds</p> <p>Determines the forward/reverse setting for the #8 Preset Speed (F287).</p> <p>Settings:</p> <ul style="list-style-type: none"> Forward Reverse 	<p>Direct Access Number — F388</p> <p>Parameter Type — Selection List</p> <p>Factory Default — Forward</p> <p>Changeable During Run — No</p>
<p>Preset Speed Direction #9</p> <p>Program ⇒ Pattern Run Control Parameters ⇒ Preset Speeds</p> <p>Determines the forward/reverse setting for the #9 Preset Speed (F288).</p> <p>Settings:</p> <ul style="list-style-type: none"> Forward Reverse 	<p>Direct Access Number — F389</p> <p>Parameter Type — Selection List</p> <p>Factory Default — Forward</p> <p>Changeable During Run — No</p>
<p>Preset Speed Direction #10</p> <p>Program ⇒ Pattern Run Control Parameters ⇒ Preset Speeds</p> <p>Determines the forward/reverse setting for the #10 Preset Speed (F289).</p> <p>Settings:</p> <ul style="list-style-type: none"> Forward Reverse 	<p>Direct Access Number — F390</p> <p>Parameter Type — Selection List</p> <p>Factory Default — Forward</p> <p>Changeable During Run — No</p>
<p>Preset Speed Direction #11</p> <p>Program ⇒ Pattern Run Control Parameters ⇒ Preset Speeds</p> <p>Determines the forward/reverse setting for the #11 Preset Speed (F290).</p> <p>Settings:</p> <ul style="list-style-type: none"> Forward Reverse 	<p>Direct Access Number — F391</p> <p>Parameter Type — Selection List</p> <p>Factory Default — Forward</p> <p>Changeable During Run — No</p>
<p>Preset Speed Direction #12</p> <p>Program ⇒ Pattern Run Control Parameters ⇒ Preset Speeds</p> <p>Determines the forward/reverse setting for the #12 Preset Speed (F291).</p> <p>Settings:</p> <ul style="list-style-type: none"> Forward Reverse 	<p>Direct Access Number — F392</p> <p>Parameter Type — Selection List</p> <p>Factory Default — Forward</p> <p>Changeable During Run — No</p>

<p>Preset Speed Direction #13</p> <p>Program ⇒ Pattern Run Control Parameters ⇒ Preset Speeds</p> <p>Determines the forward/reverse setting for the #13 Preset Speed (F292).</p> <p>Settings:</p> <ul style="list-style-type: none"> Forward Reverse 	<p>Direct Access Number — F393</p> <p>Parameter Type — Selection List</p> <p>Factory Default — Forward</p> <p>Changeable During Run — No</p>
<p>Preset Speed Direction #14</p> <p>Program ⇒ Pattern Run Control Parameters ⇒ Preset Speeds</p> <p>Determines the forward/reverse setting for the #14 Preset Speed (F293).</p> <p>Settings:</p> <ul style="list-style-type: none"> Forward Reverse 	<p>Direct Access Number — F394</p> <p>Parameter Type — Selection List</p> <p>Factory Default — Forward</p> <p>Changeable During Run — No</p>
<p>Preset Speed Direction #15</p> <p>Program ⇒ Pattern Run Control Parameters ⇒ Preset Speeds</p> <p>Determines the forward/reverse setting for the #15 Preset Speed (F294).</p> <p>Settings:</p> <ul style="list-style-type: none"> Forward Reverse 	<p>Direct Access Number — F395</p> <p>Parameter Type — Selection List</p> <p>Factory Default — Forward</p> <p>Changeable During Run — No</p>
<p>Vector Motor Model Autotune Command</p> <p>Program ⇒ Motor Parameters ⇒ Vector Motor Model</p> <p>This parameter sets the Autotune command status.</p> <p>Settings:</p> <ul style="list-style-type: none"> Autotune Disabled Reset Motor Defaults Enable Autotune on Run Command 	<p>Direct Access Number — F400</p> <p>Parameter Type — Selection List</p> <p>Factory Default — Autotune Disabled</p> <p>Changeable During Run — No</p>
<p>Vector Motor Model Slip Frequency Gain</p> <p>Program ⇒ Motor Parameters ⇒ Vector Motor Model</p> <p>This parameter provides a degree of slip compensation for a given load. A higher setting here decreases the slip allowed for a given load/ASD output ratio.</p>	<p>Direct Access Number — F401</p> <p>Parameter Type — Numerical</p> <p>Factory Default — 0.60</p> <p>Changeable During Run — Yes</p> <p>Minimum — 0.00</p> <p>Maximum — 2.55</p>
<p>Motor Constant 1 (primary resistance)</p> <p>Program ⇒ Motor Parameters ⇒ Vector Motor Model</p> <p>This parameter is the measurement of the stator resistance and is considered a Motor Constant (unchanging). This value is used in conjunction with other constants to tune the motor.</p> <p>To use Vector Control, Automatic Torque Boost, or Automatic Energy-saving, the Motor Constant setting (motor tuning) is required.</p>	<p>Direct Access Number — F402</p> <p>Parameter Type — Numerical</p> <p>Factory Default — (ASD-dependent)</p> <p>Changeable During Run — No</p> <p>Minimum — 0.0</p> <p>Maximum — 100,000 MΩ</p> <p>Units — Ω</p>

<p>Motor Constant 2 (secondary resistance)</p> <p>Program ⇒ Motor Parameters ⇒ Vector Motor Model</p> <p>This parameter is the measurement of the rotor resistance and is considered a Motor Constant (unchanging). This value is used in conjunction with other constants to tune the motor.</p> <p>This setting (motor tuning) is required to use the Vector Control, Automatic Torque Boost, or Automatic Energy-saving functions.</p>	<p>Direct Access Number — F403</p> <p>Parameter Type — Numerical</p> <p>Factory Default — (ASD-dependent)</p> <p>Changeable During Run — No</p> <p>Minimum — 0.00</p> <p>Maximum — Open</p> <p>Units — Ω</p>
<p>Motor Constant 3 (exciting inductance)</p> <p>Program ⇒ Motor Parameters ⇒ Vector Motor Model</p> <p>This parameter is used to input the excitation inductance for the motor. This value is used in conjunction with other constants to tune the motor.</p> <p>This setting (motor tuning) is required to use the Vector Control, Automatic Torque Boost, or Automatic Energy-saving functions.</p>	<p>Direct Access Number — F404</p> <p>Parameter Type — Numerical</p> <p>Factory Default — (ASD-dependent)</p> <p>Changeable During Run — No</p> <p>Minimum — 0.00</p> <p>Maximum — 6500.0</p> <p>Units — μH</p>
<p>Motor Constant 4 (load inertia)</p> <p>Program ⇒ Motor Parameters ⇒ Vector Motor Model</p> <p>This parameter is used to control the load inertia during speed changes. Acceleration and deceleration overshoot may be reduced by increasing this value.</p> <p>This setting (motor tuning) is required to use the Vector Control, Automatic Torque Boost, or Automatic Energy-saving functions.</p>	<p>Direct Access Number — F405</p> <p>Parameter Type — Numerical</p> <p>Factory Default — 1.0</p> <p>Changeable During Run — Yes</p> <p>Minimum — 0.0</p> <p>Maximum — 100.0</p>
<p>Motor Constant 5 (leakage inductance)</p> <p>Program ⇒ Motor Parameters ⇒ Vector Motor Model</p> <p>This parameter provides slight increases in the output voltage of the drive at the high speed range.</p> <p>This setting (motor tuning) is required to use the Vector Control, Automatic Torque Boost, or Automatic Energy-saving functions.</p>	<p>Direct Access Number — F410</p> <p>Parameter Type — Numerical</p> <p>Factory Default — (ASD-dependent)</p> <p>Changeable During Run — No</p> <p>Minimum — 0.00</p> <p>Maximum — 650.0</p>
<p>Number of Poles of Motor</p> <p>Program ⇒ Motor Parameters ⇒ Motor Settings</p> <p>This parameter identifies the number of motor poles.</p>	<p>Direct Access Number — F411</p> <p>Parameter Type — Numerical</p> <p>Factory Default — 4</p> <p>Changeable During Run — No</p> <p>Minimum — 2</p> <p>Maximum — 16</p>
<p>Motor Capacity</p> <p>Program ⇒ Motor Parameters ⇒ Motor Settings</p> <p>This parameter identifies the wattage rating of the motor.</p>	<p>Direct Access Number — F412</p> <p>Parameter Type — Numerical</p> <p>Factory Default — (ASD-dependent)</p> <p>Changeable During Run — No</p> <p>Minimum — 0.10</p> <p>Maximum — (ASD-dependent)</p> <p>Units — kW</p>

<p>Motor Type</p> <p>Program ⇒ Motor Parameters ⇒ Motor Settings</p> <p>This parameter identifies the type of motor being used.</p> <p>Settings:</p> <ul style="list-style-type: none"> Toshiba EQP III TEFC Toshiba EQP III ODP Toshiba EPACT TEFC Toshiba EPACT ODP Other Motor 	<p>Direct Access Number — F413</p> <p>Parameter Type — Selection List</p> <p>Factory Default — Toshiba EQP III TEFC</p> <p>Changeable During Run — No</p>
<p>Motor Constant 3 Enable</p> <p>Program ⇒ Motor Parameters ⇒ Vector Motor Model</p> <p>This parameter Enables/Disables tuning of Motor Constant 3 during an Autotune.</p> <p>Settings:</p> <ul style="list-style-type: none"> Disabled Enabled (box checked) 	<p>Direct Access Number — F414</p> <p>Parameter Type — Check Box</p> <p>Factory Default — Enable</p> <p>Changeable During Run — No</p>
<p>Torque Command</p> <p>Program ⇒ Torque Setting Parameters ⇒ Torque Control</p> <p>When operating in the Torque Control mode, this parameter allows the user to select the source of the torque command signal.</p> <p>Settings:</p> <ul style="list-style-type: none"> VI/II RR RX RX2 (option) LED Keypad Option Binary/BCD Input Common Serial (TTL) RS232/RS485 Communication Card 	<p>Direct Access Number — F420</p> <p>Parameter Type — Selection List</p> <p>Factory Default — RX</p> <p>Changeable During Run — Yes</p>
<p>Torque Command Filter</p> <p>Program ⇒ Torque Setting Parameters ⇒ Torque Control</p> <p>This parameter reduces the motor vibration caused by large-inertia loads. A small value will have a great effect while an increased value will have a lesser effect.</p>	<p>Direct Access Number — F421</p> <p>Parameter Type — Numerical</p> <p>Factory Default — 200.0</p> <p>Changeable During Run — Yes</p> <p>Minimum — 10.0</p> <p>Maximum — 200.0</p>

Synchronized Torque Bias InputProgram ⇒ Torque Setting Parameters ⇒ **Torque Control**

This parameter **Enables/Disables** the **Synchronized Torque Bias** input function. When enabled, this parameter identifies the source of the **Synchronized Torque Bias** input signal.

Settings:

- Disabled
- VI/II
- RR
- RX
- RX2 (option)
- LED Keypad Option
- Binary/BCD Input
- Common Serial (TTL)
- RS232/RS485
- Communication Card

Direct Access Number — F422Parameter Type — **Selection list**Factory Default — **Disabled**Changeable During Run — **Yes**

Tension Torque Bias InputProgram ⇒ Torque Setting Parameters ⇒ **Torque Control**

This parameter **Enables/Disables** the **Tension Torque Bias** input function and identifies the source of the **Tension Torque Bias** input signal when enabled.

Settings:

- Disabled
- VI/II
- RR
- RX
- RX2 (option)
- LED Keypad Option
- Binary/BCD Input
- Common Serial (TTL)
- RS232/RS485
- Communication Card

Direct Access Number — F423Parameter Type — **Selection List**Factory Default — **Disabled**Changeable During Run — **Yes**

Load Sharing Gain InputProgram ⇒ Torque Setting Parameters ⇒ **Torque Control**

This parameter **Enables/Disables** the **Load Sharing Gain** input function and is enabled by selecting a **Load Sharing Gain** input signal source.

Settings:

- Disabled
- VI/II
- RR
- RX
- RX2 (option)
- LED Keypad Option
- Binary/BCD Input
- Common Serial (TTL)
- RS232/RS485
- Communication Card

Direct Access Number — F424Parameter Type — **Selection List**Factory Default — **Disabled**Changeable During Run — **Yes**

F425

F428

Forward Speed Limit InputProgram ⇒ Torque Setting Parameters ⇒ **Torque Speed Limiting**

This parameter **Enables/Disables** the **Forward Speed Limit Input** control function. When enabled and operating in the **Torque Control** mode, the forward speed limit is controlled by the terminal selected here. If **Setting** is selected, the value set at **F426** is used as the **Forward Speed Limit** input.

Settings:

- Disabled
- VI/II
- RR
- RX
- RX2 (option)
- Setting

Direct Access Number — F425Parameter Type — **Selection List**Factory Default — **Disabled**Changeable During Run — **Yes****Forward Speed Limit Level**Program ⇒ Torque Setting Parameters ⇒ **Torque Control**

This parameter provides a value to be used as the **Forward Speed Limit** setting if **Setting** is selected at **F425**.

Direct Access Number — F426Parameter Type — **Numerical**Factory Default — **80.0**Changeable During Run — **Yes**

Minimum — 0.00

Maximum — **Upper Limit (F012)**

Units — Hz

Reverse Speed Limit InputProgram ⇒ Torque Setting Parameters ⇒ **Torque Control**

This parameter **Enables/Disables** the **Reverse Speed Limit Input** control function. When enabled and operating in the **Torque Control** mode, the reverse speed limit is controlled by the terminal selected here. If **Setting** is selected, the value set at **F428** is used as the **Reverse Speed Limit** input.

Settings:

- Disabled
- VI/II
- RR
- RX
- RX2 (option)
- Setting

Direct Access Number — F427Parameter Type — **Selection List**Factory Default — **Disabled**Changeable During Run — **Yes****Reverse Speed Limit Level**Program ⇒ Torque Setting Parameters ⇒ **Torque Control**

This parameter provides a value to be used as the **Reverse Speed Limit** setting if **Setting** is selected at **F427**.

Direct Access Number — F428Parameter Type — **Numerical**Factory Default — **80.0**Changeable During Run — **Yes**

Minimum — 0.00

Maximum — **Upper Limit (F012)**

Units — Hz

<p>Torque Command Mode</p> <p>Program ⇒ Torque Setting Parameters ⇒ Torque Speed Limiting</p> <p>This parameter specifies whether the torque command function is to be used in one direction or both (F/R).</p> <p>Settings:</p> <ul style="list-style-type: none"> Fixed Direction F/R Permitted 	<p>Direct Access Number — F429</p> <p>Parameter Type — Selection List</p> <p>Factory Default — Fixed Direction</p> <p>Changeable During Run — No</p>
<p>Speed Limit (torque) Reference</p> <p>Program ⇒ Torque Setting Parameters ⇒ Torque Speed Limiting</p> <p>The system has the ability to limit the amount that the speed may vary as a function of a changing load while operating in the Torque Control mode. This parameter sets the input terminal that will be used to control the allowable speed variance.</p> <p>Settings:</p> <ul style="list-style-type: none"> None VI/II RR RX RX2 (option) Fixed 	<p>Direct Access Number — F430</p> <p>Parameter Type — Selection List</p> <p>Factory Default — None</p> <p>Changeable During Run — Yes</p>
<p>Speed Limit Torque Level</p> <p>Program ⇒ Torque Setting Parameters ⇒ Torque Speed Limiting</p> <p>The system has the ability to limit the amount that the speed may vary as a function of a changing load while operating in the Torque Control mode. This parameter sets the targeted speed. The plus-or-minus value (range) for this setting may be set at F432.</p>	<p>Direct Access Number — F431</p> <p>Parameter Type — Numerical</p> <p>Factory Default — 0.00</p> <p>Changeable During Run — Yes</p> <p>Minimum — 0.00</p> <p>Maximum — Max. Freq. (F011)</p> <p>Units — Hz</p>
<p>Speed Limit Torque Range</p> <p>Program ⇒ Torque Setting Parameters ⇒ Torque Speed Limiting</p> <p>The system has the ability to limit the amount that the speed may vary as a function of a changing load while operating in the Torque Control mode. This parameter sets a plus-or-minus value (range) for the Speed Limit Torque Level (F431).</p>	<p>Direct Access Number — F432</p> <p>Parameter Type — Numerical</p> <p>Factory Default — 0.00</p> <p>Changeable During Run — Yes</p> <p>Minimum — 0.00</p> <p>Maximum — Max. Freq. (F011)</p> <p>Units — Hz</p>
<p>Speed Limit Torque Recovery</p> <p>Program ⇒ Torque Setting Parameters ⇒ Torque Speed Limiting</p> <p>The system has the ability to limit the amount that the speed may vary as a function of a changing load while operating in the Torque Control mode. This parameter sets the response time of the system to torque change requirements.</p>	<p>Direct Access Number — F433</p> <p>Parameter Type — Numerical</p> <p>Factory Default — 0.20</p> <p>Changeable During Run — No</p> <p>Minimum — 0.00</p> <p>Maximum — 2.50</p> <p>Units — Seconds</p>

<p>Power Running Torque Limit #1</p> <p>Program ⇒ Torque Setting Parameters ⇒ Torque Limit Settings</p> <p>This parameter determines the source of the control signal for the positive torque limit setting. If Setting is selected, the value set at F441 is used as the Power Running Torque Limit #1 input.</p> <p>Settings:</p> <ul style="list-style-type: none"> VI/II RR RX RX2 (option) Setting 	<p>Direct Access Number — F440</p> <p>Parameter Type — Selection List</p> <p>Factory Default — Setting</p> <p>Changeable During Run — Yes</p>
<p>Driving Torque Limit #1</p> <p>Program ⇒ Torque Setting Parameters ⇒ Manual Torque Limit Settings</p> <p>This parameter provides a value for the Power Running Torque Limit #1 setting if Setting is selected at F440. This value provides the positive torque upper limit for the #1 motor.</p>	<p>Direct Access Number — F441</p> <p>Parameter Type — Numerical</p> <p>Factory Default — 250.0</p> <p>Changeable During Run — Yes</p> <p>Minimum — 0.00</p> <p>Maximum — 250.0</p> <p>Units — %</p>
<p>Regeneration Torque Limit #1</p> <p>Program ⇒ Torque Setting Parameters ⇒ Torque Limit Settings</p> <p>This parameter determines the source of the Regenerative Torque Limit control signal. If Setting is selected, the value set at F443 is used for this parameter.</p> <p>Settings:</p> <ul style="list-style-type: none"> VI/II RR RX RX2 (option) Setting 	<p>Direct Access Number — F442</p> <p>Parameter Type — Selection List</p> <p>Factory Default — Setting</p> <p>Changeable During Run — Yes</p>
<p>Regeneration Torque Limit Setting #1</p> <p>Program ⇒ Torque Setting Parameters ⇒ Torque Limit Settings ⇒ Manual Settings</p> <p>This parameter provides a value to be used as the Regeneration Torque Limit #1 if Setting is selected at F442.</p>	<p>Direct Access Number — F443</p> <p>Parameter Type — Numerical</p> <p>Factory Default — 250.0</p> <p>Changeable During Run — Yes</p> <p>Minimum — 0.00</p> <p>Maximum — 250.0</p> <p>Units — %</p>
<p>Driving Torque Limit #2</p> <p>Program ⇒ Torque Setting Parameters ⇒ Manual Torque Limit Settings</p> <p>This parameter is used to set the positive torque upper limit for the #2 motor profile when multiple motors are controlled by a single drive or when a single motor is to be controlled by multiple profiles.</p>	<p>Direct Access Number — F444</p> <p>Parameter Type — Numerical</p> <p>Factory Default — 250.0</p> <p>Changeable During Run — Yes</p> <p>Minimum — 0.00</p> <p>Maximum — 250.0</p> <p>Units — %</p>

<p>Regeneration Torque Limit #2</p> <p>Program ⇒ Torque Setting Parameters ⇒ Manual Torque Limit Settings</p> <p>This parameter is used to set the negative torque upper limit for the #2 motor profile when multiple motors are controlled by a single drive or when a single motor is to be controlled by multiple profiles.</p>	<p>Direct Access Number — F445</p> <p>Parameter Type — Numerical</p> <p>Factory Default — 250.0</p> <p>Changeable During Run — Yes</p> <p>Minimum — 0.00</p> <p>Maximum — 250.0</p> <p>Units — %</p>
<p>Driving Torque Limit #3</p> <p>Program ⇒ Torque Setting Parameters ⇒ Manual Torque Limit Settings</p> <p>This parameter is used to set the positive torque upper limit for the #3 motor profile when multiple motors are controlled by a single drive or when a single motor is to be controlled by multiple profiles.</p>	<p>Direct Access Number — F446</p> <p>Parameter Type — Numerical</p> <p>Factory Default — 250.0</p> <p>Changeable During Run — Yes</p> <p>Minimum — 0.00</p> <p>Maximum — 250.0</p> <p>Units — %</p>
<p>Regeneration Torque Limit #3</p> <p>Program ⇒ Torque Setting Parameters ⇒ Manual Torque Limit Settings</p> <p>This parameter is used to set the negative torque upper limit for the #3 motor profile when multiple motors are controlled by a single drive or when a single motor is to be controlled by multiple profiles.</p>	<p>Direct Access Number — F447</p> <p>Parameter Type — Numerical</p> <p>Factory Default — 250.0</p> <p>Changeable During Run — Yes</p> <p>Minimum — 0.00</p> <p>Maximum — 250.0</p> <p>Units — %</p>
<p>Driving Torque Limit #4</p> <p>Program ⇒ Torque Setting Parameters ⇒ Manual Torque Limit Settings</p> <p>This parameter is used to set the positive torque upper limit for the #4 motor profile when multiple motors are controlled by a single drive or when a single motor is to be controlled by multiple profiles.</p>	<p>Direct Access Number — F448</p> <p>Parameter Type — Numerical</p> <p>Factory Default — 250.0</p> <p>Changeable During Run — Yes</p> <p>Minimum — 0.00</p> <p>Maximum — 250.0</p> <p>Units — %</p>
<p>Regeneration Torque Limit #4</p> <p>Program ⇒ Torque Setting Parameters ⇒ Manual Torque Limit Settings</p> <p>This parameter is used to set the negative torque upper limit for the #4 motor profile when multiple motors are controlled by a single drive or when a single motor is to be controlled by multiple profiles.</p>	<p>Direct Access Number — F449</p> <p>Parameter Type — Numerical</p> <p>Factory Default — 250.0</p> <p>Changeable During Run — Yes</p> <p>Minimum — 0.00</p> <p>Maximum — 250.0</p> <p>Units — %</p>
<p>Torque Limit Mode</p> <p>Program ⇒ Torque Setting Parameters ⇒ Torque Limit Settings ⇒ Torque Limit Mode</p> <p>Contact Toshiba's Marketing Department for information on this parameter.</p> <p>Settings:</p> <ul style="list-style-type: none"> Driving/Regen Positive/Negative 	<p>Direct Access Number — F450</p> <p>Parameter Type — Selection List</p> <p>Factory Default — Driving/Regen</p> <p>Changeable During Run — No</p>

<p>Torque Limit Mode (Speed Dependent)</p> <p>Program ⇒ Torque Setting Parameters ⇒ Torque Limit Settings ⇒ Torque Limit Mode (Speed Dependent)</p> <p>This parameter allows for either wide or very limited speed fluctuations while operating in the Torque Control mode.</p> <p>The ASD output follows the commanded speed when No Speed Cooperation is selected and has a very limited speed fluctuation range when Standard is selected.</p> <p>Settings:</p> <ul style="list-style-type: none"> Standard No Speed Cooperation 	<p>Direct Access Number — F451</p> <p>Parameter Type — Selection List</p> <p>Factory Default — Standard</p> <p>Changeable During Run — Yes</p>
<p>Continued Stall Until Trip During Power Operation</p> <p>Program ⇒ Protection Parameters ⇒ Stall ⇒ Continuing Stall Period</p> <p>This parameter allows the user to extend the Overvoltage Stall (F305) and the Overcurrent Stall (F017) time settings.</p>	<p>Direct Access Number — F452</p> <p>Parameter Type — Numerical</p> <p>Factory Default — 0.0</p> <p>Changeable During Run — Yes</p> <p>Minimum — 0.0</p> <p>Maximum — 1.00</p> <p>Units — Seconds</p>
<p>Stall Prevention During Regeneration</p> <p>Program ⇒ Protection Parameters ⇒ Stall ⇒ Stall Prevention During Regeneration</p> <p>This parameter Enables/Disables the Overvoltage Stall (F305) and the Overcurrent Stall (F017) function during regeneration <u>only</u>. Application-specific conditions may occur that warrant disabling the Stall function during regeneration.</p> <p>Settings:</p> <ul style="list-style-type: none"> With Stall Prevention Without Stall Prevention 	<p>Direct Access Number — F453</p> <p>Parameter Type — Selection List</p> <p>Factory Default — With Stall Prevention.</p> <p>Changeable During Run — Yes</p>
<p>Current Differential Gain</p> <p>Program ⇒ Special Control Parameters ⇒ Special Parameters ⇒ Current Differential Gain</p> <p>This parameter determines the degree that the current differential function affects the output signal. The larger the value entered here, the more pronounced the Current Differential Gain.</p>	<p>Direct Access Number — F454</p> <p>Parameter Type — Numerical</p> <p>Factory Default — 1.23</p> <p>Changeable During Run — Yes</p> <p>Minimum — 0.00</p> <p>Maximum — 327.6</p>

VI/II Bias Adjust

Program ⇒ Frequency Setting Parameters ⇒ Speed Reference
Setpoints ⇒ VI/II ⇒ **Bias**

This parameter is used to fine-tune the bias of the **VI/II** input terminals.

Note: See note on [pg. 47](#) for further information on the VI/II terminal.

This setting may be used to ensure that the zero level of the input source (pot, pressure transducer, flow meter, etc.) is also the zero level setting of the ASD system.

This is accomplished by setting the input source to zero and either increasing or decreasing this setting to provide an output of zero from the ASD.

Direct Access Number — F470

Parameter Type — **Numerical**

Factory Default — **100**

Changeable During Run — **Yes**

Minimum — 0.0

Maximum — 255

VI/II Gain Adjust

Program ⇒ Frequency Setting Parameters ⇒ Speed Reference
Setpoints ⇒ VI/II ⇒ **Gain**

This parameter is used to fine tune the gain of the **VI/II** input terminals.

Note: See note on [pg. 47](#) for further information on the VI/II terminal.

This setting may be used to ensure that the 100% level of the input source (pot, pressure transducer, flow meter, etc.) is also the 100% level setting of the ASD system.

This is accomplished by setting the input source to 100% and either increasing or decreasing this setting to provide an output of 100% from the ASD.

Direct Access Number — F471

Parameter Type — **Numerical**

Factory Default — **50**

Changeable During Run — **Yes**

Minimum — 0.0

Maximum — 255

RR Bias Adjust

Program ⇒ Frequency Setting Parameters ⇒ Speed Reference
Setpoints ⇒ RR ⇒ **Bias**

This parameter is used to fine tune the bias of the **RR** input terminal when this terminal is used as the control input while operating in the **Speed Control** or the **Torque Control** mode.

This setting may be used to ensure that the zero level of the input source (pot, pressure transducer, flow meter, etc.) is also the zero level setting of the ASD system.

This is accomplished by setting the input source to zero and either increasing or decreasing this setting to provide an output of zero from the ASD.

Direct Access Number — F472

Parameter Type — **Numerical**

Factory Default — **120**

Changeable During Run — **Yes**

Minimum — 0.0

Maximum — 255

RR Gain Adjust

Program ⇒ Frequency Setting Parameters ⇒ Speed Reference
Setpoints ⇒ RR ⇒ **Gain**

This parameter is used to fine tune the gain of the **RR** input terminal when this terminal is used as the control input while operating in the **Speed Control** or the **Torque Control** mode.

This setting may be used to ensure that the 100% level of the input source (pot, pressure transducer, flow meter, etc.) is also the 100% level setting of the ASD system.

This is accomplished by setting the input source to 100% and either increasing or decreasing this setting to provide an output of 100% from the ASD.

Direct Access Number — F473

Parameter Type — **Numerical**

Factory Default — **61**

Changeable During Run — **Yes**

Minimum — 0.0

Maximum — 255

RX Bias Adjust

Program ⇒ Frequency Setting Parameters ⇒ Speed Reference
Setpoints ⇒ RX ⇒ **Bias**

This parameter is used to fine tune the bias of the **RX** input terminal when this terminal is used as the control input while operating in the **Speed Control** or the **Torque Control** mode.

This setting may be used to ensure that the zero level of the input source (pot, pressure transducer, flow meter, etc.) is also the zero level setting of the ASD system.

This is accomplished by setting the input source to zero and either increasing or decreasing this setting to provide an output of zero from the ASD.

Direct Access Number — F474

Parameter Type — **Numerical**

Factory Default — **99**

Changeable During Run — **Yes**

Minimum — 0.0

Maximum — 255

RX Gain Adjust

Program ⇒ Frequency Setting Parameters ⇒ Speed Reference
Setpoints ⇒ RX ⇒ **Gain**

This parameter is used to fine tune the gain of the **RX** input terminal when this terminal is used as the control input while operating in the **Speed Control** or the **Torque Control** mode.

This setting may be used to ensure that the 100% level of the input source (pot, pressure transducer, flow meter, etc.) is also the 100% level setting of the ASD system.

This is accomplished by setting the input source to 100% and either increasing or decreasing this setting to provide an output of 100% from the ASD.

Direct Access Number — F475

Parameter Type — **Numerical**

Factory Default — **141**

Changeable During Run — **Yes**

Minimum — 0.0

Maximum — 255

RX2 Bias Adjust

Program ⇒ Frequency Setting Parameters ⇒ Speed Reference
Setpoints ⇒ RX2 ⇒ **Bias**

This parameter is used to fine tune the bias of the **RX2** input terminal when this terminal is used as the control input while operating in the **Speed Control** or the **Torque Control** mode.

This setting may be used to ensure that the zero level of the input source (pot, pressure transducer, flow meter, etc.) is also the zero level setting of the ASD system.

This is accomplished by setting the input source to zero and either increasing or decreasing this setting to provide a zero output from the ASD.

Direct Access Number — F476

Parameter Type — **Numerical**

Factory Default — **99**

Changeable During Run — **Yes**

Minimum — 0.0

Maximum — 255

RX2 Gain Adjust

Program ⇒ Frequency Setting Parameters ⇒ Speed Reference
Setpoints ⇒ RX2 ⇒ **Gain**

This parameter is used to fine tune the gain of the **RX2** input terminal when this terminal is used as the control input while operating in the **Speed Control** or the **Torque Control** mode.

This setting may be used to ensure that the 100% level of the input source (pot, pressure transducer, flow meter, etc.) is also the 100% level setting of the ASD system.

This is accomplished by setting the input source to 100% and either increasing or decreasing this setting to provide an output of 100% from the ASD.

Direct Access Number — F477

Parameter Type — **Numerical**

Factory Default — **141**

Changeable During Run — **Yes**

Minimum — 0.0

Maximum — 255

<p>Exciting Strengthening Coefficient</p> <p>Program ⇒ Special Control Parameters ⇒ Special Parameters⇒ Exciting Strengthening Coefficient</p> <p>This parameter determines the rate at which the excitation current is allowed to go from zero to saturation and is enabled at F481.</p>	<p>Direct Access Number — F480</p> <p>Parameter Type — Numerical</p> <p>Factory Default — 64</p> <p>Changeable During Run — Yes</p> <p>Minimum — 0</p> <p>Maximum — 255</p>
<p>Over Exciting Cooperation</p> <p>Program ⇒ Special Control Parameters ⇒ Special Parameters⇒ Over-Exciting Cooperation</p> <p>This parameter determines the method used to control the rate that the excitation current is allowed to reach saturation. If Effective is selected, the preset Torque Control or Speed Control settings will determine the rate that the motor reaches excitation saturation.</p> <p>Settings:</p> <p>Effective Applied by F480</p>	<p>Direct Access Number — F481</p> <p>Parameter Type — Selection List</p> <p>Factory Default — Effective</p> <p>Changeable During Run — Yes</p>
<p>Current Vector Control</p> <p>Program ⇒ Special Control Parameters ⇒ Special Parameters⇒ Control Margin Modulation ⇒ % Current Vector Control</p> <p>This parameter establishes the control margin of modulation when operating in the Current Vector Control mode.</p>	<p>Direct Access Number — F482</p> <p>Parameter Type — Numerical</p> <p>Factory Default — 90.0</p> <p>Changeable During Run — Yes</p> <p>Minimum — 80.0</p> <p>Maximum — 300.0</p> <p>Units — %</p>
<p>Voltage Vector Control</p> <p>Program ⇒ Special Control Parameters ⇒ Special Parameters⇒ Control Margin Modulation ⇒ % Voltage Vector Control</p> <p>This parameter establishes the control margin of modulation while operating in the Voltage Vector Control mode.</p>	<p>Direct Access Number — F483</p> <p>Parameter Type — Numerical</p> <p>Factory Default — 105.0</p> <p>Changeable During Run — Yes</p> <p>Minimum — 80.0</p> <p>Maximum — 300.0</p> <p>Units — %</p>
<p>Constant Vector Control</p> <p>Program ⇒ Special Control Parameters ⇒ Special Parameters⇒ Control Margin Modulation ⇒ % Voltage Vector Control</p> <p>This parameter establishes the control margin of modulation while operating in the Constant Vector Control mode.</p>	<p>Direct Access Number — F484</p> <p>Parameter Type — Numerical</p> <p>Factory Default — 105.0</p> <p>Changeable During Run — Yes</p> <p>Minimum — 80.0</p> <p>Maximum — 300.0</p> <p>Units — %</p>
<p>Stall Cooperation Gain at Field Weakening Zone</p> <p>Program ⇒ Special Control Parameters ⇒ Special Parameters⇒ Stall Cooperation Gain at Field Weakening Zone</p> <p>This parameter determines the degree that the Stall function is effective while operating the motor in the field weakening zone.</p>	<p>Direct Access Number — F485</p> <p>Parameter Type — Numerical</p> <p>Factory Default — 128</p> <p>Changeable During Run — Yes</p> <p>Minimum — 0</p> <p>Maximum — 255</p>

<p>Excitation Starting Rate</p> <p>Program ⇒ Special Control Parameters ⇒ Special Parameters⇒ Excitation Starting Rate</p> <p>This parameter establishes the rate of increase in the excitation current from a zero output of the ASD.</p>	<p>Direct Access Number — F486</p> <p>Parameter Type — Numerical</p> <p>Factory Default — 163.8</p> <p>Changeable During Run — Yes</p> <p>Minimum — 1.64</p> <p>Maximum — 327.6</p>
<p>Compensation Coefficient for Iron Loss</p> <p>Program ⇒ Special Control Parameters ⇒ Special Parameters⇒ Compensation Coefficient for Iron Loss</p> <p>This parameter compensates for losses in the rotor-to-stator coupling of the excitation and torque current energy.</p>	<p>Direct Access Number — F487</p> <p>Parameter Type — Numerical</p> <p>Factory Default — 105.0</p> <p>Changeable During Run — Yes</p> <p>Minimum — 0</p> <p>Maximum — 255</p>
<p>Voltage Compensation Coefficient for Dead Time</p> <p>Program ⇒ Special Control Parameters ⇒ Special Parameters⇒ Voltage Compensation Coefficient for Dead Time</p> <p>This parameter adjusts the degree of voltage compensation during dead time by increasing or decreasing the on-time of the programmed PWM just prior to the start of the dead time.</p>	<p>Direct Access Number — F488</p> <p>Parameter Type — Numerical</p> <p>Factory Default — 163.8</p> <p>Changeable During Run — Yes</p> <p>Minimum — 1.64</p> <p>Maximum — 327.6</p>
<p>Dead Time Compensation (Enable)</p> <p>Program ⇒ Special Control Parameters ⇒ Special Parameters⇒ Dead Time Compensation</p> <p>This parameter Enables/Disables the Dead Time Compensation function. The Dead Time Compensation feature provides a smoothing of the on-off IGBT signal that feeds the Gate Driver board during the off portion of the on-off cycle.</p> <p>Settings:</p> <ul style="list-style-type: none"> Enabled Disabled 	<p>Direct Access Number — F489</p> <p>Parameter Type — Selection List</p> <p>Factory Default — Enabled</p> <p>Changeable During Run — Yes</p>
<p>Dead-time Compensation Bias</p> <p>Program ⇒ Special Control Parameters ⇒ Special Parameters⇒ Dead-time Compensation Bias</p> <p>This parameter sets a bias for the Dead-time Compensation function. The Dead-time Compensation feature provides a smoothing of the on-off IGBT signal that feeds the Gate Driver board.</p>	<p>Direct Access Number — F490</p> <p>Parameter Type — Numerical</p> <p>Factory Default — 0.000</p> <p>Changeable During Run — Yes</p> <p>Minimum — -32.768</p> <p>Maximum — 32.767</p>
<p>Switching Frequency of Current/Voltage Control</p> <p>Program ⇒ Special Control Parameters ⇒ Special Parameters ⇒ Switching Frequency between Current and Voltage Control</p> <p>This parameter sets the threshold frequency at which ASD control is switched between Current-control and Voltage -control.</p>	<p>Direct Access Number — F491</p> <p>Parameter Type — Numerical</p> <p>Factory Default — 40.00</p> <p>Changeable During Run — Yes</p> <p>Minimum — 10.00</p> <p>Maximum — 60.00</p> <p>Units — Hz</p>

Accel #2 Time

Program ⇒ Special Control Parameters ⇒ **#1 – #4 Settings**

This parameter specifies the time in seconds for the drive to go from 0.0 Hz to the **Maximum Frequency** for the **#2 Acceleration** profile. The accel/decel pattern may be set using **F502**. The minimum accel/decel time may be set using **F508**.

This setting is also used to determine the acceleration rate of the **Motorized Pot** function.

***Note:** An acceleration time shorter than the load will allow may cause nuisance tripping and mechanical stress to loads. Automatic Accel/Decel and Stall settings may lengthen the acceleration time.*

Direct Access Number — F500

Parameter Type — **Numerical**

Factory Default — **(ASD-dependent)**

Changeable During Run — **Yes**

Minimum — 0.1

Maximum — 6000

Units — Seconds

Decel #2 Time

Program ⇒ Special Control Parameters ⇒ **Accel/Decel #1 – #4 Settings**

This parameter specifies the time in seconds for the drive to go from the **Maximum Frequency** to 0.0 Hz for the **#2 Deceleration** profile. The accel/decel pattern may be set using **F502**. The minimum accel/decel time may be set using **F508**.

This setting is also used to determine the deceleration rate of the **Motorized Pot** function.

***Note:** A deceleration time shorter than the load will allow may cause nuisance tripping and mechanical stress to loads. Automatic Accel/Decel and Stall settings may lengthen the acceleration time.*

Direct Access Number — F501

Parameter Type — **Numerical**

Factory Default — **(ASD-dependent)**

Changeable During Run — **Yes**

Minimum — 0.1

Maximum — 6000

Units — Seconds

Accel/Decel Pattern #1

Program ⇒ Special Control Parameters ⇒ **Accel/Decel #1 – #4 Settings**

This parameter enables a user-selected preprogrammed output profile that controls the acceleration and deceleration pattern for the **#1 Accel/Decel** parameter.

Settings:

- Linear
- S-Pattern 1
- S-Pattern 2

Direct Access Number — F502

Parameter Type — **Selection List**

Factory Default — **Linear**

Changeable During Run — **Yes**

The figures below provide a profile of the available accel/decel patterns.

Linear acceleration and deceleration is the default pattern and is used on most applications.

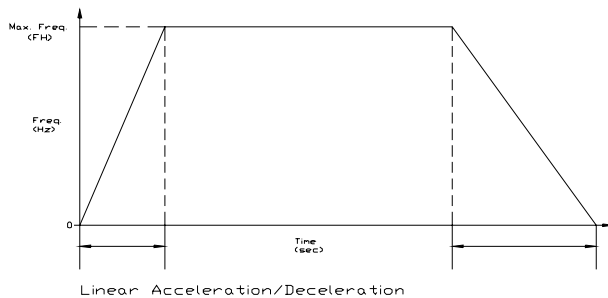

S-pattern 1 is used for applications that require quick acceleration and deceleration. This setting is also popular for applications that require shock absorption at the start of acceleration or deceleration.

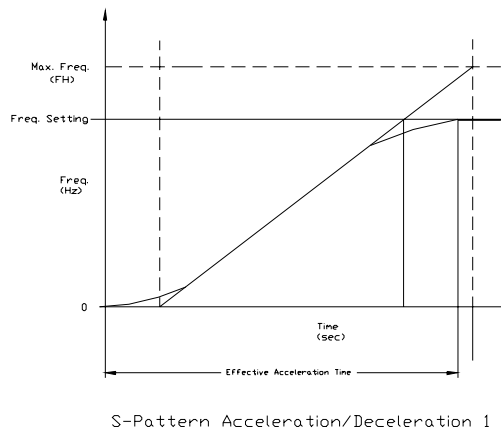

S-pattern 2 acceleration and deceleration decreases the rate of change above the base frequency.

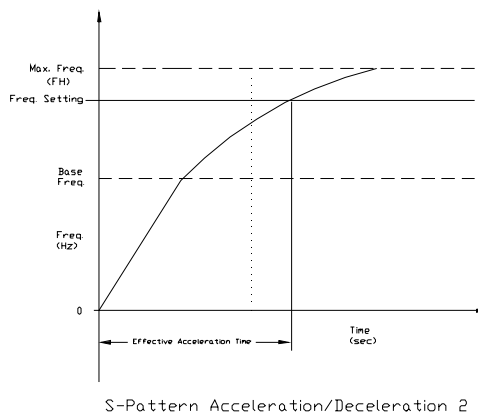

Accel/Decel Pattern #2

Program ⇒ Special Control Parameters ⇒ **1 – #4 Settings**

This parameter enables a user-selected preprogrammed output profile that controls the acceleration and deceleration pattern for the **#2 Accel/Decel** parameter.

Settings:

- Linear
- S-Pattern 1
- S-Pattern 2

Direct Access Number — F503

Parameter Type — **Selection List**

Factory Default — **Linear**

Changeable During Run — **Yes**

Acc/Dec Group

No path available (Direct Access Only)

While operating using the **LED Keypad Option** this parameter selects the accel/decel profile to be used during a multiple-accel/decel profile configuration. The accel/decel setting for selections 1 – 4 may be found at **F009, F500, F510, and F514**, respectively.

Settings:

- Group 1
- Group 2
- Group 3
- Group 4

Note: If using the LCD EOI, press ESC from the Frequency Command screen to access this parameter.

Direct Access Number — F504

Parameter Type — **Selection List**

Factory Default — **1**

Changeable During Run — **Yes**

Acc/Dec Switching Frequency #1

Program ⇒ Special Control Parameters ⇒ **Accel/Decel Special**

This parameter sets the frequency at which the acceleration control is switched from the **Accel #1** profile to the **Accel #2** profile during a multiple-acceleration profile configuration.

Direct Access Number — F505

Parameter Type — **Numerical**

Factory Default — **0.00**

Changeable During Run — **Yes**

Minimum — 0.00

Maximum — **Max. Freq. (F011)**

Units — Hz

S-Pattern Lower Limit Adjustment

Program ⇒ Special Control Parameters ⇒ **Accel/Decel Special**

Sets the lower limit of **S-pattern 1** and **2**.

Direct Access Number — F506

Parameter Type — **Numerical**

Factory Default — **25.00**

Changeable During Run — **Yes**

Minimum — 0.00

Maximum — 50.00

Units — %

S-Pattern Upper Limit Adjustment

Program ⇒ Special Control Parameters ⇒ **Accel/Decel Special**

Sets the upper limit frequency of **S-pattern 1** and **2**.

Direct Access Number — F507

Parameter Type — **Numerical**

Factory Default — **25.00**

Changeable During Run — **Yes**

Minimum — 0.00

Maximum — 50.00

Units — %

<p>Accel/Decel Lower Limit Time</p> <p>Program ⇒ Special Control Parameters ⇒ Accel/Decel Special</p> <p>This parameter sets the lower limit of the Accel/Decel time.</p>	<p>Direct Access Number — F508</p> <p>Parameter Type — Numerical</p> <p>Factory Default — 0.10</p> <p>Changeable During Run — Yes</p> <p>Minimum — 0.01</p> <p>Maximum — 10.00</p> <p>Units — Seconds</p>
<p>Accel #3 Time</p> <p>Program ⇒ Special Control Parameters ⇒ Accel/Decel #1 – #4 Settings</p> <p>This parameter specifies the time in seconds for the drive to go from 0.0 Hz to the Maximum Frequency for the #3 Acceleration profile. The accel/decel pattern may be set using F502. The minimum accel/decel time may be set using F508.</p> <p><i>Note: An acceleration time shorter than the load will allow may cause nuisance tripping and mechanical stress to loads. Automatic Accel/Decel and Stall settings may lengthen the acceleration time.</i></p>	<p>Direct Access Number — F510</p> <p>Parameter Type — Numerical</p> <p>Factory Default — (ASD-dependent)</p> <p>Changeable During Run — Yes</p> <p>Minimum — 0.1</p> <p>Maximum — 6000</p> <p>Units — Seconds</p>
<p>Decel #3 Time</p> <p>Program ⇒ Special Control Parameters ⇒ Accel/Decel #1 – #4 Settings</p> <p>This parameter specifies the time in seconds for the drive to go from the Maximum Frequency to 0.0 Hz for the #3 Deceleration profile.</p> <p>The accel/decel pattern may be set using F502. The minimum accel/decel time may be set using F508.</p> <p><i>Note: A deceleration time shorter than the load will allow may cause nuisance tripping and mechanical stress to loads. Automatic Accel/Decel and Stall settings may lengthen the deceleration time.</i></p>	<p>Direct Access Number — F511</p> <p>Parameter Type — Numerical</p> <p>Factory Default — (ASD-dependent)</p> <p>Changeable During Run — Yes</p> <p>Minimum — 0.1</p> <p>Maximum — 6000</p> <p>Units — Seconds</p>
<p>Accel/Decel Pattern #3</p> <p>Program ⇒ Special Control Parameters ⇒ Accel/Decel #1 – #4 Settings</p> <p>This parameter enables a user-selected preprogrammed output profile that controls the acceleration and deceleration pattern for the #3 Accel/Decel parameter.</p> <p>Settings:</p> <ul style="list-style-type: none"> Linear S-Pattern 1 S-Pattern 2 	<p>Direct Access Number — F512</p> <p>Parameter Type — Selection List</p> <p>Factory Default — Linear</p> <p>Changeable During Run — Yes</p>

<p>Accel/Decel Switching Frequency #2</p> <p>Program ⇒ Special Control Parameters ⇒ Accel/Decel Special</p> <p>This parameter sets the frequency at which the acceleration control is switched from the Accel #2 profile to the Accel #3 profile during a multiple-acceleration profile configuration.</p>	<p>Direct Access Number — F513</p> <p>Parameter Type — Numerical</p> <p>Factory Default — 0.00</p> <p>Changeable During Run — Yes</p> <p>Minimum — 0.00</p> <p>Maximum — Max. Freq. (F011)</p> <p>Units — Hz</p>
<p>Accel #4 Time</p> <p>Program ⇒ Special Control Parameters ⇒ Accel/Decel #1 – #4 Settings</p> <p>This parameter specifies the time in seconds for the drive to go from 0.0 Hz to the Maximum Frequency for the #4 Acceleration profile. The accel/decel pattern may be set using F502. The minimum accel/decel time may be set using F508.</p> <p><i>Note: An acceleration time shorter than the load will allow may cause nuisance tripping and mechanical stress to loads. Automatic Accel/Decel and Stall settings may lengthen the acceleration time.</i></p>	<p>Direct Access Number — F514</p> <p>Parameter Type — Numerical</p> <p>Factory Default — (ASD-dependent)</p> <p>Changeable During Run — Yes</p> <p>Minimum — 0.1</p> <p>Maximum — 6000</p> <p>Units — Seconds</p>
<p>Decel #4 Time</p> <p>Program ⇒ Special Control Parameters ⇒ Accel/Decel #1 – #4 Settings</p> <p>This parameter specifies the time in seconds for the drive to go from the Maximum Frequency to 0.0 Hz for the #4 Deceleration profile. The accel/decel pattern may be set using F502. The minimum accel/decel time may be set using F508.</p> <p><i>Note: A deceleration time shorter than the load will allow may cause nuisance tripping and mechanical stress to loads. Automatic Accel/Decel and Stall settings may lengthen the deceleration time.</i></p>	<p>Direct Access Number — F515</p> <p>Parameter Type — Numerical</p> <p>Factory Default — (ASD-dependent)</p> <p>Changeable During Run — Yes</p> <p>Minimum — 0.1</p> <p>Maximum — 6000</p> <p>Units — Seconds</p>
<p>Accel/Decel Pattern #4</p> <p>Program ⇒ Special Control Parameters ⇒ Accel/Decel #1 – #4 Settings</p> <p>This parameter enables a user-selected preprogrammed output profile that controls the acceleration and deceleration pattern for the #4 Accel/Decel parameter.</p> <p>Settings:</p> <ul style="list-style-type: none"> Linear S-Pattern 1 S-Pattern 2 	<p>Direct Access Number — F516</p> <p>Parameter Type — Selection List</p> <p>Factory Default — Linear</p> <p>Changeable During Run — Yes</p>

Accel/Decel Switching Frequency #3Program ⇒ Special Control Parameters ⇒ **Accel/Decel Special**

This parameter sets the frequency at which the acceleration control is switched from the **Accel #3** profile to the **Accel #4** profile during a multiple-acceleration profile configuration.

Direct Access Number — F517Parameter Type — **Numerical**Factory Default — **0.00**Changeable During Run — **Yes**

Minimum — 0.00

Maximum — **Max. Freq. (F011)**

Units — Hz

Pattern RunProgram ⇒ Pattern Run Control Parameters ⇒ **Pattern Run**

This parameter **Enables/Disables** the **Pattern Run** mode. When enabled, this feature allows up to 15 **Preset Speeds** to be run sequentially for a user-determined duration and number of times.

Direct Access Number — F520Parameter Type — **Check Box**Factory Default — **Disabled**Changeable During Run — **No**

Settings:

Disabled

Enabled (box checked)

Pattern Run Description

User-defined **Preset Speeds** are labeled 1 – 15 (see [F018](#)). The ID number of any one of the fifteen frequencies (1 – 15) may be entered into the **Speed #** field of the **Pattern Run** screen and run for the number of times entered into the **Repeat** field (see [F530](#)). The execution of grouped **Preset Speeds** in this manner is called a **Pattern Run**.

Skip may be selected to ignore a **Speed #** field.

Pattern Run Setup

1. Configure an unused discrete input terminal for **Pattern #1** (2, 3, or 4). This terminal will initiate the selected **Pattern Run**. The input terminal settings may be configured via Program ⇒ Terminal Selection Parameters ⇒ **Input Terminals** (see [Table 8 on pg. 77](#) for available input terminal settings).
2. Enable the **Pattern Run** mode of operation via Program ⇒ Pattern Run Control Parameters ⇒ Pattern Run ⇒ **Enable/Disable** (check box).
3. Configure the **Preset Speeds** that are to be used as the **Group Speed** set of frequencies via Program ⇒ Pattern Run Control Parameters ⇒ **Preset Speeds** (e.g., [Preset Speed #1 on pg. 67](#)).
4. Configure the **Group Speeds** by associating the **Preset Speeds** that are to be enabled and grouped (from step 3) as **Group Speed 1** (2, 3, or 4) via Program ⇒ Pattern Run Control Parameters ⇒ **Speeds**. Set the **Repeat** field to the number of times that the selected group is to be run. Set unused speed settings to **Skip**.
5. From the **Remote** mode (**Local|Remote** light is off), initiate a **Run** command (e.g., **F** and/or **R** terminal **On**).
6. Connect the input terminal that was configured in step 1 to **CC** and the **Pattern Run** will start and continue as programmed. Open the connection to stop the **Pattern Run** before its conclusion.

See [F018 on pg. 67](#) for further information on this parameter.

<p>Pattern Run Mode Restart Command</p> <p>Program ⇒ Pattern Run Control Parameters ⇒ Pattern Run</p> <p>This parameter sets the start condition of subsequent Pattern Runs after the initial Pattern Run has been terminated or has completed its programming.</p> <p>Settings:</p> <ul style="list-style-type: none"> Reset Continue 	<p>Direct Access Number — F521</p> <p>Parameter Type — Selection List</p> <p>Factory Default — Disabled</p> <p>Changeable During Run — No</p>
<p>Group #1 Speed Repeat Factor</p> <p>Program ⇒ Pattern Run Control Parameters ⇒ Speeds</p> <p>This parameter sets the number of times that the pattern defined in Group #1 will be run.</p>	<p>Direct Access Number — F530</p> <p>Parameter Type — Numerical</p> <p>Factory Default — 1</p> <p>Changeable During Run — No</p> <p>Minimum — 1</p> <p>Maximum — Infinite</p>
<p>Group #1 Speed #1 (Pattern Run)</p> <p>Program ⇒ Pattern Run Control Parameters ⇒ Speeds</p> <p>Up to four groups of Preset Speeds may be setup and run from this screen. The Preset Speed numbers (1 – 15) may be entered into the Speed # field to be run for the number of times entered into the Repeat field (0 – 254) or forever by selecting Infinite. Running multiple Preset Speeds as a group is called a Pattern Run.</p> <p>This parameter allows the user to run the Preset Speeds 1 – 15 as a group and is identified as Group #1.</p> <p>Skip may be selected to ignore a Preset Speed entry.</p> <p>See F520 for further information on this setting.</p>	<p>Direct Access Number — F531</p> <p>Parameter Type — Selection List</p> <p>Factory Default — 1</p> <p>Changeable During Run — No</p>
<p>Group #1 Speed #2</p> <p>Program ⇒ Pattern Run Control Parameters ⇒ Speeds</p> <p>Same as #1 Group Speed #1 (see F531).</p>	<p>Direct Access Number — F532</p> <p>Parameter Type — Selection List</p> <p>Factory Default — 2</p> <p>Changeable During Run — No</p>
<p>Group #1 Speed #3</p> <p>Program ⇒ Pattern Run Control Parameters ⇒ Speeds</p> <p>Same as #1 Group Speed #1 (see F531).</p>	<p>Direct Access Number — F533</p> <p>Parameter Type — Selection List</p> <p>Factory Default — 3</p> <p>Changeable During Run — No</p>
<p>Group #1 Speed #4</p> <p>Program ⇒ Pattern Run Control Parameters ⇒ Speeds</p> <p>Same as #1 Group Speed #1 (see F531).</p>	<p>Direct Access Number — F534</p> <p>Parameter Type — Selection List</p> <p>Factory Default — 4</p> <p>Changeable During Run — No</p>
<p>Group #1 Speed #5</p> <p>Program ⇒ Pattern Run Control Parameters ⇒ Speeds</p> <p>Same as #1 Group Speed #1 (see F531).</p>	<p>Direct Access Number — F535</p> <p>Parameter Type — Selection List</p> <p>Factory Default — 5</p> <p>Changeable During Run — No</p>

<p>Group #1 Speed #6</p> <p>Program ⇒ Pattern Run Control Parameters ⇒ Speeds</p> <p>Same as #1 Group Speed #1 (see F531).</p>	<p>Direct Access Number — F536</p> <p>Parameter Type — Selection List</p> <p>Factory Default — 6</p> <p>Changeable During Run — No</p>
<p>Group #1 Speed #7</p> <p>Program ⇒ Pattern Run Control Parameters ⇒ Speeds</p> <p>Same as #1 Group Speed #1 (see F531).</p>	<p>Direct Access Number — F537</p> <p>Parameter Type — Selection List</p> <p>Factory Default — 7</p> <p>Changeable During Run — No</p>
<p>Group #1 Speed #8</p> <p>Program ⇒ Pattern Run Control Parameters ⇒ Speeds</p> <p>Same as #1 Group Speed #1 (see F531).</p>	<p>Direct Access Number — F538</p> <p>Parameter Type — Selection List</p> <p>Factory Default — 8</p> <p>Changeable During Run — No</p>
<p>Group #2 Speed Repeat Factor</p> <p>Program ⇒ Pattern Run Control Parameters ⇒ Speeds</p> <p>This parameter sets the number of times that the enabled preset speeds of Group #2 will be run; 0 – 254 or Infinite.</p>	<p>Direct Access Number — F540</p> <p>Parameter Type — Selection List</p> <p>Factory Default — 1</p> <p>Changeable During Run — No</p>
<p>Group #2 Speed #1</p> <p>Program ⇒ Pattern Run Control Parameters ⇒ Speeds</p> <p>Same as #1 Group Speed #1 (see F531).</p>	<p>Direct Access Number — F541</p> <p>Parameter Type — Selection List</p> <p>Factory Default — 9</p> <p>Changeable During Run — No</p>
<p>Group #2 Speed #2</p> <p>Program ⇒ Pattern Run Control Parameters ⇒ Speeds</p> <p>Same as #1 Group Speed #1 (see F531).</p>	<p>Direct Access Number — F542</p> <p>Parameter Type — Selection List</p> <p>Factory Default — 10</p> <p>Changeable During Run — No</p>
<p>Group #2 Speed #3</p> <p>Program ⇒ Pattern Run Control Parameters ⇒ Speeds</p> <p>Same as #1 Group Speed #1 (see F531).</p>	<p>Direct Access Number — F543</p> <p>Parameter Type — Selection List</p> <p>Factory Default — 11</p> <p>Changeable During Run — No</p>
<p>Group #2 Speed #4</p> <p>Program ⇒ Pattern Run Control Parameters ⇒ Speeds</p> <p>Same as #1 Group Speed #1 (see F531).</p>	<p>Direct Access Number — F544</p> <p>Parameter Type — Selection List</p> <p>Factory Default — 12</p> <p>Changeable During Run — No</p>
<p>Group #2 Speed #5</p> <p>Program ⇒ Pattern Run Control Parameters ⇒ Speeds</p> <p>Same as #1 Group Speed #1 (see F531).</p>	<p>Direct Access Number — F545</p> <p>Parameter Type — Selection List</p> <p>Factory Default — 13</p> <p>Changeable During Run — No</p>
<p>Group #2 Speed #6</p> <p>Program ⇒ Pattern Run Control Parameters ⇒ Speeds</p> <p>Same as #1 Group Speed #1 (see F531).</p>	<p>Direct Access Number — F546</p> <p>Parameter Type — Selection List</p> <p>Factory Default — 14</p> <p>Changeable During Run — No</p>

<p>Group #2 Speed #7</p> <p>Program ⇒ Pattern Run Control Parameters ⇒ Speeds</p> <p>Same as #1 Group Speed #1 (see F531).</p>	<p>Direct Access Number — F547</p> <p>Parameter Type — Selection List</p> <p>Factory Default — 15</p> <p>Changeable During Run — No</p>
<p>Group #2 Speed #8</p> <p>Program ⇒ Pattern Run Control Parameters ⇒ Speeds</p> <p>Same as #1 Group Speed #1 (see F531).</p>	<p>Direct Access Number — F548</p> <p>Parameter Type — Selection List</p> <p>Factory Default — Skip</p> <p>Changeable During Run — No</p>
<p>Group #3 Speed Repeat Factor</p> <p>Program ⇒ Pattern Run Control Parameters ⇒ Speeds</p> <p>This parameter sets the number of times that the enabled preset speeds of Group #3 will be run; 0 – 254 or Infinite.</p>	<p>Direct Access Number — F550</p> <p>Parameter Type — Selection List</p> <p>Factory Default — 1</p> <p>Changeable During Run — No</p>
<p>Group #3 Speed #1</p> <p>Program ⇒ Pattern Run Control Parameters ⇒ Speeds</p> <p>Same as #1 Group Speed #1 (see F531).</p>	<p>Direct Access Number — F551</p> <p>Parameter Type — Selection List</p> <p>Factory Default — 1</p> <p>Changeable During Run — No</p>
<p>Group #3 Speed #2</p> <p>Program ⇒ Pattern Run Control Parameters ⇒ Speeds</p> <p>Same as #1 Group Speed #1 (see F531).</p>	<p>Direct Access Number — F552</p> <p>Parameter Type — Selection List</p> <p>Factory Default — 2</p> <p>Changeable During Run — No</p>
<p>Group #3 Speed #3</p> <p>Program ⇒ Pattern Run Control Parameters ⇒ Speeds</p> <p>Same as #1 Group Speed #1 (see F531).</p>	<p>Direct Access Number — F553</p> <p>Parameter Type — Selection List</p> <p>Factory Default — 3</p> <p>Changeable During Run — No</p>
<p>Group #3 Speed #4</p> <p>Program ⇒ Pattern Run Control Parameters ⇒ Speeds</p> <p>Same as #1 Group Speed #1 (see F531).</p>	<p>Direct Access Number — F554</p> <p>Parameter Type — Selection List</p> <p>Factory Default — 4</p> <p>Changeable During Run — No</p>
<p>Group #3 Speed #5</p> <p>Program ⇒ Pattern Run Control Parameters ⇒ Speeds</p> <p>Same as #1 Group Speed #1 (see F531).</p>	<p>Direct Access Number — F555</p> <p>Parameter Type — Selection List</p> <p>Factory Default — 5</p> <p>Changeable During Run — No</p>
<p>Group #3 Speed #6</p> <p>Program ⇒ Pattern Run Control Parameters ⇒ Speeds</p> <p>Same as #1 Group Speed #1 (see F531).</p>	<p>Direct Access Number — F556</p> <p>Parameter Type — Selection List</p> <p>Factory Default — 6</p> <p>Changeable During Run — No</p>
<p>Group #3 Speed #7</p> <p>Program ⇒ Pattern Run Control Parameters ⇒ Speeds</p> <p>Same as #1 Group Speed #1 (see F531).</p>	<p>Direct Access Number — F557</p> <p>Parameter Type — Selection List</p> <p>Factory Default — 7</p> <p>Changeable During Run — No</p>

<p>Group #3 Speed #8</p> <p>Program ⇒ Pattern Run Control Parameters ⇒ Speeds</p> <p>Same as #1 Group Speed #1 (see F531).</p>	<p>Direct Access Number — F558</p> <p>Parameter Type — Selection List</p> <p>Factory Default — 8</p> <p>Changeable During Run — No</p>
<p>Group #4 Speed Repeat Factor</p> <p>Program ⇒ Pattern Run Control Parameters ⇒ Speeds</p> <p>This parameter sets the number of times that the enabled preset speeds of Group #4 will be run; 1 – 254 or Infinite.</p>	<p>Direct Access Number — F560</p> <p>Parameter Type — Selection List</p> <p>Factory Default — 1</p> <p>Changeable During Run — No</p>
<p>Group #4 Speed #1</p> <p>Program ⇒ Pattern Run Control Parameters ⇒ Speeds</p> <p>Same as #1 Group Speed #1 (see F531).</p>	<p>Direct Access Number — F561</p> <p>Parameter Type — Selection List</p> <p>Factory Default — 9</p> <p>Changeable During Run — No</p>
<p>Group #4 Speed #2</p> <p>Program ⇒ Pattern Run Control Parameters ⇒ Speeds</p> <p>Same as #1 Group Speed #1 (see F531).</p>	<p>Direct Access Number — F562</p> <p>Parameter Type — Selection List</p> <p>Factory Default — 10</p> <p>Changeable During Run — No</p>
<p>Group #4 Speed #3</p> <p>Program ⇒ Pattern Run Control Parameters ⇒ Speeds</p> <p>Same as #1 Group Speed #1 (see F531).</p>	<p>Direct Access Number — F563</p> <p>Parameter Type — Selection List</p> <p>Factory Default — 11</p> <p>Changeable During Run — No</p>
<p>Group #4 Speed #4</p> <p>Program ⇒ Pattern Run Control Parameters ⇒ Speeds</p> <p>Same as #1 Group Speed #1 (see F531).</p>	<p>Direct Access Number — F564</p> <p>Parameter Type — Selection List</p> <p>Factory Default — 12</p> <p>Changeable During Run — No</p>
<p>Group #4 Speed #5</p> <p>Program ⇒ Pattern Run Control Parameters ⇒ Speeds</p> <p>Same as #1 Group Speed #1 (see F531).</p>	<p>Direct Access Number — F565</p> <p>Parameter Type — Selection List</p> <p>Factory Default — 13</p> <p>Changeable During Run — No</p>
<p>Group #4 Speed #6</p> <p>Program ⇒ Pattern Run Control Parameters ⇒ Speeds</p> <p>Same as #1 Group Speed #1 (see F531).</p>	<p>Direct Access Number — F566</p> <p>Parameter Type — Selection List</p> <p>Factory Default — 14</p> <p>Changeable During Run — No</p>
<p>Group #4 Speed #7</p> <p>Program ⇒ Pattern Run Control Parameters ⇒ Speeds</p> <p>Same as #1 Group Speed #1 (see F531).</p>	<p>Direct Access Number — F567</p> <p>Parameter Type — Selection List</p> <p>Factory Default — 15</p> <p>Changeable During Run — No</p>
<p>Group #4 Speed #8</p> <p>Program ⇒ Pattern Run Control Parameters ⇒ Speeds</p> <p>Same as #1 Group Speed #1 (see F531).</p>	<p>Direct Access Number — F568</p> <p>Parameter Type — Selection List</p> <p>Factory Default — Skip</p> <p>Changeable During Run — No</p>

<p>Pattern #1 Characteristics (Pattern Run)</p> <p>Program ⇒ Pattern Run Control Parameters ⇒ Preset Speeds ⇒ 1</p> <p>In conjunction with the setting of F585, this parameter is used to set the run-time of Preset Speed 1 when used as part of a Pattern Run.</p> <p>Settings:</p> <ul style="list-style-type: none"> Time From Start Time From Reach No Limit Until Next Step 	<p>Direct Access Number — F570</p> <p>Parameter Type — Selection List</p> <p>Factory Default — Time From Start</p> <p>Changeable During Run — No</p>
<p>Pattern #2 Characteristics (Pattern Run)</p> <p>Program ⇒ Pattern Run Control Parameters ⇒ Preset Speeds ⇒ 2</p> <p>Same as #1 Pattern Characteristics (see F570).</p>	<p>Direct Access Number — F571</p> <p>Parameter Type — Selection List</p> <p>Factory Default — Time From Start</p> <p>Changeable During Run — No</p>
<p>Pattern #3 Characteristics (Pattern Run)</p> <p>Program ⇒ Pattern Run Control Parameters ⇒ Preset Speeds ⇒ 3</p> <p>Same as #1 Pattern Characteristics (see F570).</p>	<p>Direct Access Number — F572</p> <p>Parameter Type — Selection List</p> <p>Factory Default — Time From Start</p> <p>Changeable During Run — No</p>
<p>Pattern #4 Characteristics (Pattern Run)</p> <p>Program ⇒ Pattern Run Control Parameters ⇒ Preset Speeds ⇒ 4</p> <p>Same as #1 Pattern Characteristics (see F570).</p>	<p>Direct Access Number — F573</p> <p>Parameter Type — Selection List</p> <p>Factory Default — Time From Start</p> <p>Changeable During Run — No</p>
<p>Pattern #5 Characteristics (Pattern Run)</p> <p>Program ⇒ Pattern Run Control Parameters ⇒ Preset Speeds ⇒ 5</p> <p>Same as #1 Pattern Characteristics (see F570).</p>	<p>Direct Access Number — F574</p> <p>Parameter Type — Selection List</p> <p>Factory Default — Time From Start</p> <p>Changeable During Run — No</p>
<p>Pattern #6 Characteristics (Pattern Run)</p> <p>Program ⇒ Pattern Run Control Parameters ⇒ Preset Speeds ⇒ 6</p> <p>Same as #1 Pattern Characteristics (see F570).</p>	<p>Direct Access Number — F575</p> <p>Parameter Type — Selection List</p> <p>Factory Default — Time From Start</p> <p>Changeable During Run — No</p>
<p>Pattern #7 Characteristics (Pattern Run)</p> <p>Program ⇒ Pattern Run Control Parameters ⇒ Preset Speeds ⇒ 7</p> <p>Same as #1 Pattern Characteristics (see F570).</p>	<p>Direct Access Number — F576</p> <p>Parameter Type — Selection List</p> <p>Factory Default — Time From Start</p> <p>Changeable During Run — No</p>
<p>Pattern #8 Characteristics (Pattern Run)</p> <p>Program ⇒ Pattern Run Control Parameters ⇒ Preset Speeds ⇒ 8</p> <p>Same as #1 Pattern Characteristics (see F570).</p>	<p>Direct Access Number — F577</p> <p>Parameter Type — Selection List</p> <p>Factory Default — Time From Start</p> <p>Changeable During Run — No</p>
<p>Pattern #9 Characteristics (Pattern Run)</p> <p>Program ⇒ Pattern Run Control Parameters ⇒ Preset Speeds ⇒ 9</p> <p>Same as #1 Pattern Characteristics (see F570).</p>	<p>Direct Access Number — F578</p> <p>Parameter Type — Selection List</p> <p>Factory Default — Time From Start</p> <p>Changeable During Run — No</p>

<p>Pattern #10 Characteristics (Pattern Run) Program ⇒ Pattern Run Control Parameters ⇒ Preset Speeds ⇒ 10</p> <p>Same as #1 Pattern Characteristics (see F570).</p>	<p>Direct Access Number — F579 Parameter Type — Selection List Factory Default — Time From Start Changeable During Run — No</p>
<p>Pattern #11 Characteristics (Pattern Run) Program ⇒ Pattern Run Control Parameters ⇒ Preset Speeds ⇒ 11</p> <p>Same as #1 Pattern Characteristics (see F570).</p>	<p>Direct Access Number — F580 Parameter Type — Selection List Factory Default — Time From Start Changeable During Run — No</p>
<p>Pattern #12 Characteristics (Pattern Run) Program ⇒ Pattern Run Control Parameters ⇒ Preset Speeds ⇒ 12</p> <p>Same as #1 Pattern Characteristics (see F570).</p>	<p>Direct Access Number — F581 Parameter Type — Selection List Factory Default — Time From Start Changeable During Run — No</p>
<p>Pattern #13 Characteristics (Pattern Run) Program ⇒ Pattern Run Control Parameters ⇒ Preset Speeds ⇒ 13</p> <p>Same as #1 Pattern Characteristics (see F570).</p>	<p>Direct Access Number — F582 Parameter Type — Selection List Factory Default — Time From Start Changeable During Run — No</p>
<p>Pattern #14 Characteristics (Pattern Run) Program ⇒ Pattern Run Control Parameters ⇒ Preset Speeds ⇒ 14</p> <p>Same as #1 Pattern Characteristics (see F570).</p>	<p>Direct Access Number — F583 Parameter Type — Selection List Factory Default — Time From Start Changeable During Run — No</p>
<p>Pattern #15 Characteristics (Pattern Run) Program ⇒ Pattern Run Control Parameters ⇒ Preset Speeds ⇒ 15</p> <p>Same as #1 Pattern Characteristics (see F570).</p>	<p>Direct Access Number — F584 Parameter Type — Selection List Factory Default — Time From Start Changeable During Run — No</p>
<p>Pattern Run #1 Run-Time Setting Program ⇒ Pattern Run Control Parameters ⇒ Preset Speeds ⇒ 1</p> <p>This parameter sets the run-time value for the #1 Preset Speed mode when used as part of a Pattern Run.</p>	<p>Direct Access Number — F585 Parameter Type — Numerical Factory Default — 5 Changeable During Run — No Minimum — 1 Maximum — 8000 Units — Seconds</p>
<p>Pattern Run #2 Continuation Mode Run-Time Setting Program ⇒ Pattern Run Control Parameters ⇒ Preset Speeds ⇒ 2</p> <p>This parameter sets the run-time value for the #2 Preset Speed mode when used as part of a Pattern Run.</p>	<p>Direct Access Number — F586 Parameter Type — Numerical Factory Default — 5 Changeable During Run — No Minimum — 1 Maximum — 8000 Units — Seconds</p>

<p>Pattern Run #3 Run-Time Setting</p> <p>Program ⇒ Pattern Run Control Parameters ⇒ Preset Speeds ⇒ 3</p> <p>This parameter sets the run-time value for the #3 Preset Speed mode when used as part of a Pattern Run.</p>	<p>Direct Access Number — F587</p> <p>Parameter Type — Numerical</p> <p>Factory Default — 5</p> <p>Changeable During Run — No</p> <p>Minimum — 1</p> <p>Maximum — 8000</p> <p>Units — Seconds</p>
<p>Pattern Run #4 Run-Time Setting</p> <p>Program ⇒ Pattern Run Control Parameters ⇒ Preset Speeds ⇒ 4</p> <p>This parameter sets the run-time value for the #4 Preset Speed mode when used as part of a Pattern Run.</p>	<p>Direct Access Number — F588</p> <p>Parameter Type — Numerical</p> <p>Factory Default — 5</p> <p>Changeable During Run — No</p> <p>Minimum — 1</p> <p>Maximum — 8000</p> <p>Units — Seconds</p>
<p>Pattern Run #5 Run-Time Setting</p> <p>Program ⇒ Pattern Run Control Parameters ⇒ Preset Speeds ⇒ 5</p> <p>This parameter sets the run-time value for the #5 Preset Speed mode when used as part of a Pattern Run.</p>	<p>Direct Access Number — F589</p> <p>Parameter Type — Numerical</p> <p>Factory Default — 5</p> <p>Changeable During Run — No</p> <p>Minimum — 1</p> <p>Maximum — 8000</p> <p>Units — Seconds</p>
<p>Pattern Run #6 Run-Time Setting</p> <p>Program ⇒ Pattern Run Control Parameters ⇒ Preset Speeds ⇒ 6</p> <p>This parameter sets the run-time value for the #6 Preset Speed mode when used as part of a Pattern Run.</p>	<p>Direct Access Number — F590</p> <p>Parameter Type — Numerical</p> <p>Factory Default — 5</p> <p>Changeable During Run — No</p> <p>Minimum — 1</p> <p>Maximum — 8000</p> <p>Units — Seconds</p>
<p>Pattern Run #7 Run-Time Setting</p> <p>Program ⇒ Pattern Run Control Parameters ⇒ Preset Speeds ⇒ 7</p> <p>This parameter sets the run-time value for the #7 Preset Speed mode when used as part of a Pattern Run.</p>	<p>Direct Access Number — F591</p> <p>Parameter Type — Numerical</p> <p>Factory Default — 5</p> <p>Changeable During Run — No</p> <p>Minimum — 1</p> <p>Maximum — 8000</p> <p>Units — Seconds</p>
<p>Pattern Run #8 Run-Time Setting</p> <p>Program ⇒ Pattern Run Control Parameters ⇒ Preset Speeds ⇒ 8</p> <p>This parameter sets the run-time value for the #8 Preset Speed mode when used as part of a Pattern Run.</p>	<p>Direct Access Number — F592</p> <p>Parameter Type — Numerical</p> <p>Factory Default — 5</p> <p>Changeable During Run — No</p> <p>Minimum — 1</p> <p>Maximum — 8000</p> <p>Units — Seconds</p>

<p>Pattern Run #9 Run-Time Setting</p> <p>Program ⇒ Pattern Run Control Parameters ⇒ Preset Speeds ⇒ 9</p> <p>This parameter sets the run-time value for the #9 Preset Speed mode when used as part of a Pattern Run.</p>	<p>Direct Access Number — F593</p> <p>Parameter Type — Numerical</p> <p>Factory Default — 5</p> <p>Changeable During Run — No</p> <p>Minimum — 1</p> <p>Maximum — 8000</p> <p>Units — Seconds</p>
<p>Pattern Run #10 Run-Time Setting</p> <p>Program ⇒ Pattern Run Control Parameters ⇒ Preset Speeds ⇒ 10</p> <p>This parameter sets the run-time value for the #10 Preset Speed mode when used as part of a Pattern Run.</p>	<p>Direct Access Number — F594</p> <p>Parameter Type — Numerical</p> <p>Factory Default — 5</p> <p>Changeable During Run — No</p> <p>Minimum — 1</p> <p>Maximum — 8000</p> <p>Units — Seconds</p>
<p>Pattern Run #11 Run-Time Setting</p> <p>Program ⇒ Pattern Run Control Parameters ⇒ Preset Speeds ⇒ 11</p> <p>This parameter sets the run-time value for the #11 Preset Speed mode when used as part of a Pattern Run.</p>	<p>Direct Access Number — F595</p> <p>Parameter Type — Numerical</p> <p>Factory Default — 5</p> <p>Changeable During Run — No</p> <p>Minimum — 1</p> <p>Maximum — 8000</p> <p>Units — Seconds</p>
<p>Pattern Run #12 Run-Time Setting</p> <p>Program ⇒ Pattern Run Control Parameters ⇒ Preset Speeds ⇒ 12</p> <p>This parameter sets the run-time value for the #12 Preset Speed mode when used as part of a Pattern Run.</p>	<p>Direct Access Number — F596</p> <p>Parameter Type — Numerical</p> <p>Factory Default — 5</p> <p>Changeable During Run — No</p> <p>Minimum — 1</p> <p>Maximum — 8000</p> <p>Units — Seconds</p>
<p>Pattern Run #13 Run-Time Setting</p> <p>Program ⇒ Pattern Run Control Parameters ⇒ Preset Speeds ⇒ 13</p> <p>This parameter sets the run-time value for the #13 Preset Speed mode when used as part of a Pattern Run.</p>	<p>Direct Access Number — F597</p> <p>Parameter Type — Numerical</p> <p>Factory Default — 5</p> <p>Changeable During Run — No</p> <p>Minimum — 1</p> <p>Maximum — 8000</p> <p>Units — Seconds</p>
<p>Pattern Run #14 Run-Time Setting</p> <p>Program ⇒ Pattern Run Control Parameters ⇒ Preset Speeds ⇒ 14</p> <p>This parameter sets the run-time value for the #14 Preset Speed mode when used as part of a Pattern Run.</p>	<p>Direct Access Number — F598</p> <p>Parameter Type — Numerical</p> <p>Factory Default — 5</p> <p>Changeable During Run — No</p> <p>Minimum — 1</p> <p>Maximum — 8000</p> <p>Units — Seconds</p>

<p>Pattern Run #15 Run-Time Setting</p> <p>Program ⇒ Pattern Run Control Parameters ⇒ Preset Speeds ⇒ 15</p> <p>This parameter sets the run-time value for the #15 Preset Speed mode when used as part of a Pattern Run.</p>	<p>Direct Access Number — F599</p> <p>Parameter Type — Numerical</p> <p>Factory Default — 5</p> <p>Changeable During Run — No</p> <p>Minimum — 1</p> <p>Maximum — 8000</p> <p>Units — Seconds</p>
<p>Electronic Thermal Protection #1</p> <p>Program ⇒ Motor Parameters ⇒ Motor Set #1</p> <p>The Motor #1 Electronic Thermal Protection parameter specifies the motor overload current level for motor set #1. This value is entered as either a percentage of the full load rating of the ASD or as the FLA of the motor.</p> <p>The unit of measurement for this parameter may be set to Amps or it may be set as a percentage of the ASD rating. The name-plated FLA of the motor may be entered directly when Amps is selected as the unit of measurement (see F701 to change the display unit).</p> <p>Electronic Thermal Protection settings (#1 – #4) will be displayed in Amps if the EOI display units are set to V/A rather than %.</p>	<p>Direct Access Number — F600</p> <p>Parameter Type — Numerical</p> <p>Factory Default — 100.0</p> <p>Changeable During Run — Yes</p> <p>Minimum — 10.0</p> <p>Maximum — 100.0</p> <p>Units — %</p>
<p>Overcurrent Stall Level</p> <p>Program ⇒ Protection Parameters ⇒ Stall</p> <p>This parameter specifies the output current level at which the output frequency is reduced in an attempt to prevent a trip. The overcurrent level is entered as a percentage of the maximum rating of the drive.</p> <p><i>Note: Parameter F017 (Soft Stall) must be enabled to use this feature.</i></p>	<p>Direct Access Number — F601</p> <p>Parameter Type — Numerical</p> <p>Factory Default — (ASD-dependent)</p> <p>Changeable During Run — Yes</p> <p>Minimum — 0.00</p> <p>Maximum — 200.0</p> <p>Units — %</p>
<p>Trip Save at Power Down Enable</p> <p>Program ⇒ Protection Parameters ⇒ Trip Settings</p> <p>This parameter Enables/Disables the Trip Save at Power Down setting. When enabled, this feature logs the trip event and retains the trip information when the system powers down. The trip information may be viewed from the Monitor screen.</p> <p>When disabled, the trip information will be cleared when the system powers down.</p> <p>Settings:</p> <ul style="list-style-type: none"> Disabled Enabled (box checked) 	<p>Direct Access Number — F602</p> <p>Parameter Type — Check Box</p> <p>Factory Default — Disabled</p> <p>Changeable During Run — No</p>

Emergency Off Mode SettingsProgram ⇒ Protection Parameters ⇒ **Emergency Off Settings**

This parameter determines the method used to stop the motor in the event that an **Emergency Off** command is received and the system is configured to use this feature.

This setting may also be associated with the **FL** terminals to allow the **FL** relay to change states when an **EOFF** condition occurs by setting the **FL** terminal to **Fault FL (all)** (see **F132**).

Note: A supplemental emergency stopping system should be used with the ASD. Emergency stopping should not be a task of the ASD alone.

Settings:

- Coast Stop
- Deceleration Stop
- DC Injection Braking Stop

Emergency Off DC Injection Application TimeProgram ⇒ Protection Parameters ⇒ **Emergency Off Settings**

When **DC Injection** is used as a function of receiving an **Emergency Off** command (**F603**), this parameter determines the time that the **DC Injection** braking is applied to the motor.

Direct Access Number — F603Parameter Type — **Selection List**Factory Default — **Coast Stop**Changeable During Run — **No**

Direct Access Number — F604Parameter Type — **Numerical**Factory Default — **0.10**Changeable During Run — **Yes**

Minimum — 0.00

Maximum — 10.00

Units — Seconds

Output Phase Loss DetectionProgram ⇒ Protection Parameters ⇒ **Phase Loss**

This parameter **Enables/Disables** the monitoring of each phase of the 3-phase output signal (U, V, or W) of the ASD. If either line is missing, inactive, or not of the specified level, the ASD incurs a trip.

Settings:

- Disabled
- Enabled (box checked)

Direct Access Number — F605Parameter Type — **Check Box**Factory Default — **Disabled**Changeable During Run — **No**

OL Reduction Starting FrequencyProgram ⇒ Protection Parameters ⇒ **Overload**

This parameter is used to reduce the start frequency during very low-speed motor operation. During very low-speed operation the cooling efficiency of the motor decreases. Lowering the start frequency aides in minimizing the generated heat.

Direct Access Number — F606Parameter Type — **Numerical**Factory Default — **6.00**Changeable During Run — **Yes**

Minimum — 0.00

Maximum — 30.00

Units — Hz

<p>Motor 150% OL Time Limit</p> <p>Program ⇒ Protection Parameters ⇒ Overload</p> <p>This parameter establishes a time that the motor may operate at 150% of its rated current before tripping. This setting applies the time/150% reference to the individual settings of each motor (e.g., this setting references 150% of the F600 setting for the #1 motor).</p> <p>The unit will trip sooner than the time entered here if the overload is greater than 150%.</p>	<p>Direct Access Number — F607</p> <p>Parameter Type — Numerical</p> <p>Factory Default — 600</p> <p>Changeable During Run — Yes</p> <p>Minimum — 10</p> <p>Maximum — 2400</p> <p>Units — Seconds</p>
<p>Inrush Current Suppression</p> <p>Program ⇒ Protection Parameters ⇒ Soft Start</p> <p>The startup inrush current may be suppressed for up to 2.5 seconds. This parameter determines the length of the inrush current suppression.</p>	<p>Direct Access Number — F608</p> <p>Parameter Type — Numerical</p> <p>Factory Default — 0.30</p> <p>Changeable During Run — No</p> <p>Minimum — 0.30</p> <p>Maximum — 2.50</p> <p>Units — Seconds</p>
<p>Interlock with ST</p> <p>Program ⇒ Protection Parameters ⇒ Soft Start</p> <p>This parameter Enables/Disables the ST-to-CC connection dependency on the successful completion of a Soft Start. If enabled, the ST-to-CC connection will happen only after a successful Soft Start.</p>	<p>Direct Access Number — F609</p> <p>Parameter Type — Check Box</p> <p>Factory Default — Disabled</p> <p>Changeable During Run — No</p>
<p>Low Current Trip</p> <p>Program ⇒ Protection Parameters ⇒ Low Current Settings</p> <p>This parameter Enables/Disables the low-current trip feature.</p> <p>When enabled, the drive will trip on a low-current fault if the output current of the drive falls below the level defined at F611 and remains there for the time set at F612.</p> <p>Settings:</p> <ul style="list-style-type: none"> Disabled Enabled (box checked) 	<p>Direct Access Number — F610</p> <p>Parameter Type — Check Box</p> <p>Factory Default — Disabled</p> <p>Changeable During Run — No</p>
<p>Low Current Trip Threshold</p> <p>Program ⇒ Protection Parameters ⇒ Low Current Settings</p> <p>When the low-current monitor is enabled, this function sets the low-current trip threshold. The threshold value is entered as a percentage of the maximum rating of the drive.</p>	<p>Direct Access Number — F611</p> <p>Parameter Type — Numerical</p> <p>Factory Default — 0.00</p> <p>Changeable During Run — Yes</p> <p>Minimum — 0.00</p> <p>Maximum — 100.0</p> <p>Units — %</p>
<p>Low Current Trip Threshold Time</p> <p>Program ⇒ Protection Parameters ⇒ Low Current Settings</p> <p>When the low-current monitor is enabled, this function sets the time that the low-current condition must exist to cause a trip.</p>	<p>Direct Access Number — F612</p> <p>Parameter Type — Numerical</p> <p>Factory Default — 0</p> <p>Changeable During Run — Yes</p> <p>Minimum — 0</p> <p>Maximum — 255</p> <p>Units — Seconds</p>

<p>Short Circuit Test</p> <p>Program ⇒ Protection Parameters ⇒ Arm Short Check Settings</p> <p>This parameter determines when the system will perform an Output Short Circuit test.</p> <p>Settings:</p> <ul style="list-style-type: none"> Every Run Every Powerup 	<p>Direct Access Number — F613</p> <p>Parameter Type — Selection List</p> <p>Factory Default — Every Run</p> <p>Changeable During Run — No</p>
<p>Short Circuit Test Duration</p> <p>Program ⇒ Protection Parameters ⇒ Arm Short Check Settings</p> <p>This parameter sets the pulse width of the ASD output pulse that is applied to the motor during an Output Short Circuit test.</p>	<p>Direct Access Number — F614</p> <p>Parameter Type — Numerical</p> <p>Factory Default — (ASD-dependent)</p> <p>Changeable During Run — No</p> <p>Minimum — 1</p> <p>Maximum — 100</p> <p>Units — μS</p>
<p>Overtorque Trip</p> <p>Program ⇒ Protection Parameters ⇒ Overtorque Parameters</p> <p>This parameter Enables/Disables the Over Torque Tripping function.</p> <p>When enabled, the ASD trips if an output torque value greater than the setting of F616 or F617 exists for a time longer than the setting of F618.</p> <p>When disabled, the ASD does not trip due to overtorque conditions.</p> <p>Settings:</p> <ul style="list-style-type: none"> Disabled Enabled (box checked) 	<p>Direct Access Number — F615</p> <p>Parameter Type — Check Box</p> <p>Factory Default — Disabled</p> <p>Changeable During Run — No</p>
<p>Overtorque Trip/Alarm Level (Positive Torque)</p> <p>Program ⇒ Protection Parameters ⇒ Overtorque Parameters</p> <p>This parameter sets the torque threshold level that is used as a setpoint for overtorque tripping. This setting is a percentage of the maximum rated torque of the drive.</p>	<p>Direct Access Number — F616</p> <p>Parameter Type — Numerical</p> <p>Factory Default — 150.0</p> <p>Changeable During Run — No</p> <p>Minimum — 0.00</p> <p>Maximum — 250.0</p> <p>Units — %</p>
<p>Overtorque Trip/Alarm Level (Negative Torque)</p> <p>Program ⇒ Protection Parameters ⇒ Overtorque Parameters</p> <p>This parameter sets the torque threshold level that is used as a setpoint for overtorque tripping during regeneration. This setting is a percentage of the maximum rated torque of the drive.</p>	<p>Direct Access Number — F617</p> <p>Parameter Type — Numerical</p> <p>Factory Default — 150.0</p> <p>Changeable During Run — No</p> <p>Minimum — 0.00</p> <p>Maximum — 250.0</p> <p>Units — %</p>

<p>Overtorque Detection Time</p> <p>Program ⇒ Protection Parameters ⇒ Overtorque Parameters</p> <p>This parameter sets the amount of time that the overtorque condition may exceed the tripping threshold level set at F616 and F617 before a trip occurs.</p>	<p>Direct Access Number — F618</p> <p>Parameter Type — Numerical</p> <p>Factory Default — 0.50</p> <p>Changeable During Run — No</p> <p>Minimum — 0.00</p> <p>Maximum — 100.0</p> <p>Units — Seconds</p>
<p>Cooling Fan Control</p> <p>Program ⇒ Protection Parameters ⇒ Cooling Fan Settings</p> <p>This parameter sets the cooling fan run-time command.</p> <p>Settings:</p> <ul style="list-style-type: none"> Automatic Always On 	<p>Direct Access Number — F620</p> <p>Parameter Type — Selection List</p> <p>Factory Default — Automatic</p> <p>Changeable During Run — Yes</p>
<p>Cumulative Run Timer Alarm Setting</p> <p>Program ⇒ Protection Parameters ⇒ Cumulative Run Timer</p> <p>This parameter sets a run-time value that, once exceeded, closes a contact. The output signal may be used to control external equipment or used to engage a brake.</p> <p><i>Note:</i> The time displayed is 1/10th of the actual time (0.1 hr. = 1.0 hr.).</p>	<p>Direct Access Number — F621</p> <p>Parameter Type — Numerical</p> <p>Factory Default — 175.0</p> <p>Changeable During Run — Yes</p> <p>Minimum — 0.1</p> <p>Maximum — 999.9</p> <p>Units — Hours (X 100)</p>
<p>Abnormal Speed Detection Filter Time</p> <p>Program ⇒ Protection Parameters ⇒ Abnormal Speed Settings</p> <p>This parameter sets the time that an overspeed condition must exist to cause a trip.</p>	<p>Direct Access Number — F622</p> <p>Parameter Type — Numerical</p> <p>Factory Default — 10.0</p> <p>Changeable During Run — No</p> <p>Minimum — 0.01</p> <p>Maximum — 100.0</p> <p>Units — Seconds</p>
<p>Overspeed Detection Frequency Range</p> <p>Program ⇒ Protection Parameters ⇒ Abnormal Speed Settings</p> <p>This parameter sets the upper level of the Base Frequency range that, once exceeded, will cause an Overspeed Detected alert.</p>	<p>Direct Access Number — F623</p> <p>Parameter Type — Numerical</p> <p>Factory Default — 0.0</p> <p>Changeable During Run — Yes</p> <p>Minimum — 0.0</p> <p>Maximum — 30.0</p> <p>Units — Hz</p>
<p>Speed Drop Detection Frequency Range</p> <p>Program ⇒ Protection Parameters ⇒ Abnormal Speed Settings</p> <p>This parameter sets the lower level of the Base Frequency range that, once exceeded, will cause a Speed Drop Detected alert.</p>	<p>Direct Access Number — F624</p> <p>Parameter Type — Numerical</p> <p>Factory Default — 0.00</p> <p>Changeable During Run — Yes</p> <p>Minimum — 0.00</p> <p>Maximum — 30.00</p> <p>Units — Hz</p>

<p>Overvoltage Stall Level (fast)</p> <p>Program ⇒ Protection Parameters ⇒ Stall</p> <p>This parameter sets the upper DC bus voltage threshold that, once exceeded, will cause an Overvoltage Stall. An Overvoltage Stall increases the output frequency of the drive during deceleration for a specified time in an attempt to prevent an Overvoltage Trip.</p> <p>If the overvoltage condition persists for over 250 μS, an Overvoltage Trip will be incurred.</p> <p><i>Note: This feature may increase deceleration times.</i></p>	<p>Direct Access Number — F625</p> <p>Parameter Type — Numerical</p> <p>Factory Default — (ASD-dependent)</p> <p>Changeable During Run — Yes</p> <p>Minimum — 50.00</p> <p>Maximum — 250.0</p> <p>Units — %</p>
<p>Overvoltage Stall Level</p> <p>Program ⇒ Protection Parameters ⇒ Stall</p> <p>This parameter sets the upper DC bus voltage threshold that, once exceeded, will cause an Overvoltage Stall. An Overvoltage Stall increases the output frequency of the drive during deceleration for a specified time in an attempt to prevent an Overvoltage Trip.</p> <p>If the overvoltage condition persists for over 4 mS, an Overvoltage Trip will be incurred.</p> <p><i>Note: This feature may increase deceleration times.</i></p>	<p>Direct Access Number — F626</p> <p>Parameter Type — Numerical</p> <p>Factory Default — (ASD-dependent)</p> <p>Changeable During Run — Yes</p> <p>Minimum — 50.0</p> <p>Maximum — 250.0</p> <p>Units — %</p>
<p>Undervoltage Trip</p> <p>Program ⇒ Protection Parameters ⇒ Undervoltage/Ridethrough</p> <p>This parameter Enables/Disables the Undervoltage Trip function.</p> <p>With this parameter Enabled, the ASD will trip if the undervoltage condition persists for a time greater than the F628 setting.</p> <p>A user-selected contact may be actuated if so configured.</p> <p>If Disabled the ASD will stop and not trip; the FL contact is not active.</p> <p>Settings:</p> <ul style="list-style-type: none"> Disabled Enabled (box checked) 	<p>Direct Access Number — F627</p> <p>Parameter Type — Check Box</p> <p>Factory Default — Disabled</p> <p>Changeable During Run — No</p>
<p>Undervoltage Detection Time</p> <p>Program ⇒ Protection Parameters ⇒ Undervoltage/Ridethrough</p> <p>This parameter sets the time that the undervoltage condition must exist to cause an Undervoltage trip when this function is enabled at F627.</p>	<p>Direct Access Number — F628</p> <p>Parameter Type — Numerical</p> <p>Factory Default — 0.03</p> <p>Changeable During Run — No</p> <p>Minimum — 0.00</p> <p>Maximum — 10.00</p> <p>Units — Seconds</p>
<p>Undervoltage Stall level</p> <p>Program ⇒ Protection Parameters ⇒ Undervoltage/Ridethrough</p> <p>This parameter sets the low end of the DC bus voltage threshold that, once it drops below this setting, will activate the setting of F302 (Ridethrough Mode). Activation may be the result of a momentary power loss or an excessive load on the bus voltage. Once activated, the system will attempt to maintain the bus voltage level set here until the motor stops.</p> <p><i>Note: This feature may decrease deceleration times.</i></p>	<p>Direct Access Number — F629</p> <p>Parameter Type — Numerical</p> <p>Factory Default — (ASD-dependent)</p> <p>Changeable During Run — Yes</p> <p>Minimum — 50.00</p> <p>Maximum — 100.0</p> <p>Units — %</p>

<p>Brake Trouble Internal Timer</p> <p>Program ⇒ Protection Parameters ⇒ Brake Fault Timer</p> <p>This parameter is used in conjunction with the discrete input terminal setting 64 [System Consistent Sequence (BA: braking answer)] (see item 64 of Table 8 on pg. 77 for further information on this feature).</p> <p>After activating the discrete input terminal System Consistent Sequence (B: braking release), the setting of this parameter defines a window of time in which 1) a Braking Answer response must be received or 2) the brake must release.</p> <p>Should this timer setting expire before the Braking Answer is returned or the brake releases, a Brake Fault is incurred. Otherwise, the brake releases and normal motor operations resume.</p>	<p>Direct Access Number — F630</p> <p>Parameter Type — Numerical</p> <p>Factory Default — 0.00</p> <p>Changeable During Run — Yes</p> <p>Minimum — 0.00</p> <p>Maximum — 10.00</p> <p>Units — Seconds</p>
<p>Position Difference Limit</p> <p>Program ⇒ Feedback Parameters ⇒ Feedback Settings ⇒ Position Difference Limit</p> <p>While operating in the Position Control mode, this parameter sets the maximum allowed difference between the commanded position and resulting position as indicated by encoder pulses.</p>	<p>Direct Access Number — F631</p> <p>Parameter Type — Numerical</p> <p>Factory Default — 16.0</p> <p>Changeable During Run — No</p> <p>Minimum — 0.1</p> <p>Maximum — 6553</p>
<p>Release After Run Timer</p> <p>Program ⇒ Protection Parameters ⇒ Brake Fault Timer</p> <p>This parameter sets the time that the brake will hold after the Run command criteria has been met.</p>	<p>Direct Access Number — F632</p> <p>Parameter Type — Numerical</p> <p>Factory Default — 0.00</p> <p>Changeable During Run — No</p> <p>Minimum — 0.00</p> <p>Maximum — 2.50</p> <p>Units — Seconds</p>
<p>Earth Fault Alarm Level</p> <p>Program ⇒ Protection ⇒ Earth Fault Alarm Level</p> <p>This parameter sets the threshold level (%) that must be exceeded to meet the Earth Fault Alarm activation criteria.</p>	<p>Direct Access Number — F640</p> <p>Parameter Type — Numerical</p> <p>Factory Default — 100</p> <p>Changeable During Run — Yes</p> <p>Minimum — 0</p> <p>Maximum — 100</p> <p>Units — %</p>
<p>Earth Fault Alarm Time</p> <p>Program ⇒ Protection ⇒ Earth Fault Alarm Time</p> <p>In the event that the Earth Fault Alarm activation criteria is met, a timer begins to count down to zero. Upon reaching zero, the Earth Fault Alarm is activated.</p> <p>This parameter sets the start-time of the count-down timer.</p>	<p>Direct Access Number — F641</p> <p>Parameter Type — Numerical</p> <p>Factory Default — 1.00</p> <p>Changeable During Run — Yes</p> <p>Minimum — 0.00</p> <p>Maximum — 2.50</p> <p>Units — Seconds</p>

<p>Earth Fault Trip Level</p> <p>Program ⇒ Protection ⇒ Earth Fault Trip Level</p> <p>This parameter sets the threshold level (%) that must be exceeded to meet the Earth Fault Trip activation criteria.</p>	<p>Direct Access Number — F642</p> <p>Parameter Type — Numerical</p> <p>Factory Default — 100</p> <p>Changeable During Run — Yes</p> <p>Minimum — 0.00</p> <p>Maximum — 100</p> <p>Units — %</p>
<p>Earth Fault Trip Time</p> <p>Program ⇒ Protection ⇒ Earth Fault Trip Time</p> <p>In the event that the Earth Fault Trip activation criteria is met, a timer begins to count down to zero. Upon reaching zero, the Earth Fault Trip is activated.</p> <p>This parameter sets the start-time of the count-down timer.</p>	<p>Direct Access Number — F643</p> <p>Parameter Type — Numerical</p> <p>Factory Default — 1.00</p> <p>Changeable During Run — Yes</p> <p>Minimum — 0.00</p> <p>Maximum — 2.50</p> <p>Units — Seconds</p>
<p>Acc/Dec Base Frequency Adjustment</p> <p>Program ⇒ Terminal Selection Parameters ⇒ Analog Input Functions</p> <p>This parameter Enables/Disables the feature that allows for the external adjustment of the Base Frequency. When enabled, either VI/II or RR may be used as an input source for the modification of the Base Frequency setting.</p> <p>Settings:</p> <ul style="list-style-type: none"> Disabled VI/II RR 	<p>Direct Access Number — F650</p> <p>Parameter Type — Selection List</p> <p>Factory Default — Disabled</p> <p>Changeable During Run — Yes</p>
<p>Upper Limit Frequency Adjustment</p> <p>Program ⇒ Terminal Selection Parameters ⇒ Analog Input Functions</p> <p>This parameter Enables/Disables the feature that allows for the external adjustment of the Upper Limit. When enabled, either VI/II or RR may be used as an input source for the modification of the Upper Limit setting.</p> <p>Settings:</p> <ul style="list-style-type: none"> Disabled VI/II RR 	<p>Direct Access Number — F651</p> <p>Parameter Type — Selection List</p> <p>Factory Default — Disabled</p> <p>Changeable During Run — Yes</p>
<p>Acceleration Time Adjustment</p> <p>Program ⇒ Terminal Selection Parameters ⇒ Analog Input Functions</p> <p>This parameter Enables/Disables the feature that allows for the external adjustment of the Acceleration Time. Selecting either VI/II or RR enables this feature. The selected input is used as a multiplier of the programmed Acceleration Time setting. The multiplication factor may be from 1 to 10.</p> <p><i>Note: An acceleration time shorter than the load will allow may cause nuisance tripping and mechanical stress to loads.</i></p> <p>Settings:</p> <ul style="list-style-type: none"> Disabled VI/II RR 	<p>Direct Access Number — F652</p> <p>Parameter Type — Selection List</p> <p>Factory Default — Disabled</p> <p>Changeable During Run — Yes</p>

Deceleration Time AdjustmentProgram ⇒ Terminal Selection Parameters ⇒ **Analog Input Functions**

This parameter **Enables/Disables** the feature that allows for the external adjustment of the **Deceleration Time**. Selecting either **VI/II** or **RR** enables this feature. The selected input is used as a modifier of the programmed **Deceleration Time** setting.

Note: A deceleration time shorter than the load will allow may cause nuisance tripping and mechanical stress to loads.

Settings:

Disabled
VI/II
RR

Direct Access Number — F653Parameter Type — **Selection List**Factory Default — **Disabled**Changeable During Run — **Yes**

Torque Boost AdjustmentProgram ⇒ Terminal Selection Parameters ⇒ **Analog Input Functions**

This parameter **Enables/Disables** the feature that allows for the external adjustment of the **Torque Boost** setting. Selecting either **VI/II** or **RR** enables this feature. The selected input is used as a modifier of the programmed **Torque Boost** setting.

Settings:

Disabled
VI/II
RR

Direct Access Number — F654Parameter Type — **Selection List**Factory Default — **Disabled**Changeable During Run — **Yes**

Frequency Override Additive InputProgram ⇒ Feedback Parameters ⇒ **Override Control**

This parameter **Enables/Disables** the feature that allows for the external adjustment of the **Output Frequency**.

Selecting either of the input methods listed enables this feature. The selected input is used as a modifier of the programmed **Output Frequency**.

Settings:

Disabled
VI/II
RR
RX
RX2 (option)
LED Keypad (option)
Binary/BCD Input
Common Serial (TTL)
RS232/RS485
Communication Card
Motorized Pot
Pulse Input 1

Direct Access Number — F660Parameter Type — **Selection List**Factory Default — **Disabled**Changeable During Run — **No**

Frequency Override Multiplying InputProgram ⇒ Feedback Parameters ⇒ **Override Control**

This parameter **Enables/Disables** the feature that allows for the external adjustment of the **Output Frequency**.

Selecting either of the input methods listed enables this feature. The selected input is used as a multiplier of the programmed **Output Frequency**.

If operating using the **LED Keypad Option** and **Setting** is selected, the value entered at **F729** is used as the multiplier.

Settings:

- Disabled
- VI/II
- RR
- RX
- RX2 (option)
- Setting (LED Keypad Option Only)

Direct Access Number — F661Parameter Type — **Selection List**Factory Default — **Disabled**Changeable During Run — **No**

AM Terminal AssignmentProgram ⇒ Meter Terminal Adjustment Parameters ⇒ **AM**

This setting determines the output function of the **AM** analog output terminal. This output terminal produces an output current that is proportional to the magnitude of the function assigned to this terminal. The available assignments for this output terminal are listed in [Table 7 on pg. 62](#).

Note: *To read **voltage** at this terminal a 100 – 500Ω resistor is required and must be connected from AM (+) to AM (-). The voltage is read across the 100 – 500Ω resistor.*

Current may be read by connecting an ammeter from AM (+) to AM (-).

The **AM** analog output has a maximum resolution of 1/1024. The **AM Terminal Adjustment (F671)** must be used to calibrate the output signal for a proper response. **SW-1** may be switched to allow for the full-range output to be either 0 – 1 mA or 4 – 20 mA when providing an output current, or either 0 – 1 or 1 to 7.5 volts when providing an output voltage at this terminal.

Direct Access Number — F670Parameter Type — **Selection List**Factory Default — **Output Current**Changeable During Run — **Yes**

AM Terminal AdjustmentProgram ⇒ Meter Terminal Adjustment Parameters ⇒ **AM**

This function is used to calibrate the **AM** analog output terminal.

To calibrate the **AM** analog output, connect a meter (current or voltage) as described at **F670**. With the drive running at a known frequency, adjust this parameter (**F671**) until the running frequency produces the desired DC level output at the **AM** terminal.

Direct Access Number — F671Parameter Type — **Numerical**Factory Default — **512**Changeable During Run — **Yes**

Minimum — 1

Maximum — 1280

Analog 1 Terminal SettingProgram ⇒ Meter Terminal Adjustment Parameters ⇒ **Analog 1**

This parameter sets the **Analog 1** multifunction programmable terminal to 1 of 33 possible functions and is available on the **ASD Multicom** option board only.

Possible assignments for this output terminal are listed in [Table 7 on pg. 62](#).

Direct Access Number — F672Parameter Type — **Selection List**Factory Default — **Output Voltage**Changeable During Run — **Yes**

<p>Analog 1 Terminal Adjustment</p> <p>Program ⇒ Meter Terminal Adjustment Parameters ⇒ Analog 1</p> <p>This parameter adjusts the coefficient of the Analog 1 circuit to obtain an output that corresponds with a known input.</p> <p>This function is used in the calibration of external signal measuring devices (DVM, counters, etc.).</p>	<p>Direct Access Number — F673</p> <p>Parameter Type — Numerical</p> <p>Factory Default — 512</p> <p>Changeable During Run — Yes</p> <p>Minimum — 1</p> <p>Maximum — 1280</p>
<p>Analog 2 Terminal Setting</p> <p>Program ⇒ Meter Terminal Adjustment Parameters ⇒ Analog 2</p> <p>This parameter sets the Analog 2 multifunction programmable terminal to 1 of 33 possible functions and is available on the ASD Multicom option board only.</p> <p>Possible assignments for this output terminal are listed in Table 7 on pg. 62.</p>	<p>Direct Access Number — F674</p> <p>Parameter Type — Selection List</p> <p>Factory Default — Post-compensation Frequency</p> <p>Changeable During Run — Yes</p>
<p>Analog 2 Terminal Adjustment</p> <p>Program ⇒ Meter Terminal Adjustment Parameters ⇒ Analog 2</p> <p>This parameter adjusts the coefficient of the circuit to obtain an output that corresponds with a known input.</p> <p>This function is used in the calibration of external signal measuring devices (DVM, counters, etc.).</p>	<p>Direct Access Number — F675</p> <p>Parameter Type — Numerical</p> <p>Factory Default — 512</p> <p>Changeable During Run — Yes</p> <p>Minimum — 1</p> <p>Maximum — 1280</p>
<p>FP Terminal Setting</p> <p>Program ⇒ Terminal Selection Parameters ⇒ FP</p> <p>This parameter commands the multifunction programmable FP terminal to monitor the value of 1 of 33 possible system functions. As the monitored function changes in magnitude or frequency, the pulse count of the FP output pulse train changes in direct proportion to changes in the monitored function. As the monitored value goes up so does the pulse count of the FP output.</p> <p><i>Note:</i> The duty cycle of the output pulse train remains at $65 \pm 5.0 \mu\text{s}$.</p> <p>Possible assignments for this output terminal are listed in Table 7 on pg. 62.</p>	<p>Direct Access Number — F676</p> <p>Parameter Type — Selection List</p> <p>Factory Default — Output Frequency</p> <p>Changeable During Run — Yes</p>
<p>FP Terminal Adjustment</p> <p>Program ⇒ Terminal Selection Parameters ⇒ FP</p> <p>This parameter sets the full-scale reading of the FP Terminal. The full-scale reading of the monitored variable selected in F676 may be set here.</p>	<p>Direct Access Number — F677</p> <p>Parameter Type — Numerical</p> <p>Factory Default — 3.840</p> <p>Changeable During Run — Yes</p> <p>Minimum — 1.000</p> <p>Maximum — 43.200</p> <p>Units — kHz</p>
<p>Display Units for Voltage and Current</p> <p>Program ⇒ Utility Parameters ⇒ Display Units</p> <p>This parameter sets the unit of measurement for current and voltage values displayed on the EOI.</p> <p>Settings:</p> <ul style="list-style-type: none"> % V/A 	<p>Direct Access Number — F701</p> <p>Parameter Type — Selection List</p> <p>Factory Default — %</p> <p>Changeable During Run — Yes</p>

<p>Hz Per User-defined Unit</p> <p>Program ⇒ Utility Parameters ⇒ Display Units</p> <p>This parameter allows the user to input a quantity to be displayed on the EOI that is proportional to the output frequency of the drive.</p> <p>This feature is useful when the output of a process is moved along at a rate that is proportional to the output frequency of the drive.</p>	<p>Direct Access Number — F702</p> <p>Parameter Type — Numerical</p> <p>Factory Default — 0.00</p> <p>Changeable During Run — Yes</p> <p>Minimum — 0.00</p> <p>Maximum — 200.0</p> <p>Units — Hz/UDU</p>
<p>Frequency Display Resolution</p> <p>Program ⇒ Utility Parameters ⇒ Display Units</p> <p>The parameter sets the number of decimal places to be displayed during non-Accel/Decel functions.</p>	<p>Direct Access Number — F703</p> <p>Parameter Type — Numerical</p> <p>Factory Default — 0.1</p> <p>Changeable During Run — Yes</p> <p>Minimum — 1</p> <p>Maximum — 0.01</p>
<p>Accel/Decel Special Display Resolution</p> <p>Program ⇒ Special Control Parameters ⇒ Accel/Decel Special</p> <p>This parameter sets the number of decimal places to be displayed for Accel/Decel functions.</p>	<p>Direct Access Number — F704</p> <p>Parameter Type — Numerical</p> <p>Factory Default — 0.1</p> <p>Changeable During Run — Yes</p> <p>Minimum — 1</p> <p>Maximum — 0.01</p>
<p>Prohibit Initializing User Parameters During Typeform Initialization</p> <p>Program ⇒ Special Control Parameters ⇒ Special Parameters⇒ Prohibit Initializing User Parameters During Typeform Initialization</p> <p>This parameter Enables/Disables the ability to initialize user parameters during a Type Form initialization.</p> <p>Settings:</p> <ul style="list-style-type: none"> Allowed Prohibited 	<p>Direct Access Number — F709</p> <p>Parameter Type — Selection List</p> <p>Factory Default — Allowed</p> <p>Changeable During Run — Yes</p>
<p>V/f Group</p> <p>No path available (Direct Access Only)</p> <p>While operating using the LED Keypad Option 1 of 4 V/f groups may be selected and run. Each V/f group is comprised of 4 user-defined variables: Base Frequency, Base Frequency Voltage, Manual Torque Boost, and Electronic Thermal Protection. Expanded descriptions of these parameters may be found in this section (Direct Access Parameter Information).</p> <p>Settings:</p> <ul style="list-style-type: none"> Group 1 Group 2 Group 3 Group 4 <p><i>Note: If using the LCD EOI, press ESC from the Frequency Command screen to access this parameter.</i></p>	<p>Direct Access Number — F720</p> <p>Parameter Type — Selection List</p> <p>Factory Default — 1</p> <p>Changeable During Run — Yes</p>

<p>Stop Pattern</p> <p>No path available (Direct Access Only)</p> <p>While operating using the LED Keypad Option the Stop Pattern parameter determines the method used to stop the motor when the stop command is issued via a Stop command from the LED Keypad.</p> <p>The Decel Stop setting enables the Dynamic Braking system that is setup at F304 or the DC Injection Braking system that is setup at F250, F251, and F252.</p> <p>The Coast Stop setting allows the motor to stop at the rate allowed by the inertia of the load.</p> <p>Settings:</p> <ul style="list-style-type: none"> Decel Stop Coast Stop <p><i>Note: The Stop Pattern setting has no effect on the Emergency Off settings of F603. If using the LCD EOI, press ESC from the Frequency Command screen to access this parameter.</i></p>	<p>Direct Access Number — F721</p> <p>Parameter Type — Selection List</p> <p>Factory Default — Decel Stop</p> <p>Changeable During Run — Yes</p>
<p>Torque Limit Group</p> <p>No path available (Direct Access Only)</p> <p>While operating using the LED Keypad Option this parameter is used to select 1 of 4 preset positive torque limits to apply to the active motor. The settings of profiles 1 – 4 may be setup at F441, F444, F446, and F448, respectively.</p> <p>Settings:</p> <ul style="list-style-type: none"> 1 2 3 4 <p><i>Note: If using the LCD EOI, press ESC from the Frequency Command screen to access this parameter.</i></p>	<p>Direct Access Number — F723</p> <p>Parameter Type — Selection List</p> <p>Factory Default — 1</p> <p>Changeable During Run — Yes</p>
<p>Feedback in Panel Mode</p> <p>No path available (Direct Access Only)</p> <p>While operating using the LED Keypad Option this parameter Enables/Disables PID feedback control.</p> <p>Settings:</p> <ul style="list-style-type: none"> Enabled Disabled <p><i>Note: If using the LCD EOI, press ESC from the Frequency Command screen to access this parameter.</i></p>	<p>Direct Access Number — F724</p> <p>Parameter Type — Selection List</p> <p>Factory Default — Enabled</p> <p>Changeable During Run — Yes</p>
<p>LED Option Override Multiplication Gain</p> <p>Program ⇒ Feedback Parameters ⇒ Override Control</p> <p>If operating using the LED Keypad Option this parameter provides a value to be used in the event that Setting is selected for the Frequency Override Multiplying Input (F661).</p>	<p>Direct Access Number — F729</p> <p>Parameter Type — Numerical</p> <p>Factory Default — 0.00</p> <p>Changeable During Run — Yes</p> <p>Minimum — -100.00</p> <p>Maximum — 100.00</p>

<p>LOD Control and Stopping Method</p> <p>Program ⇒ Special Control Parameters ⇒ Low Output Disable Function ⇒ LOD</p> <p>Enables/Disables the Low Output Disable function and, if enabled, selects a stopping method.</p> <p>Settings:</p> <ul style="list-style-type: none"> Disabled Enabled — Decel Stop Enabled — Coast Stop 	<p>Direct Access Number — F731</p> <p>Parameter Type — Selection List</p> <p>Factory Default — Disabled</p> <p>Changeable During Run — Yes</p>
<p>LOD Start Level (Hz)</p> <p>Program ⇒ Special Control Parameters ⇒ Low Output Disable Function ⇒ LOD Start Level (Hz)</p> <p>The Low Output Disable Start Level sets the output frequency threshold that, if exceeded, will initiate the LOD function if properly configured.</p>	<p>Direct Access Number — F732</p> <p>Parameter Type — Numerical</p> <p>Factory Default — 0.0</p> <p>Changeable During Run — Yes</p> <p>Minimum — 0.0</p> <p>Maximum — Max. Freq.</p> <p>Units — Hz</p>
<p>LOD Start Time</p> <p>Program ⇒ Special Control Parameters ⇒ Low Output Disable Function ⇒ LOD Start Time</p> <p>The Low Output Disable Start Time sets the amount of time that the LOD Start Level criteria must be met and maintained for the LOD function to be initiated.</p>	<p>Direct Access Number — F733</p> <p>Parameter Type — Numerical</p> <p>Factory Default — 0.0</p> <p>Changeable During Run — Yes</p> <p>Minimum — 0.0</p> <p>Maximum — 3600.0</p> <p>Units — Seconds</p>
<p>LOD Setpoint Boost (Hz)</p> <p>Program ⇒ Special Control Parameters ⇒ Low Output Disable Function ⇒ LOD Setpoint Boost (Hz)</p> <p>The Low Output Disable feature adds the user-input frequency value to the commanded frequency.</p>	<p>Direct Access Number — F734</p> <p>Parameter Type — Numerical</p> <p>Factory Default — 0.0</p> <p>Changeable During Run — Yes</p> <p>Minimum — 0.0</p> <p>Maximum — Max. Freq.</p> <p>Units — Hz</p>
<p>LOD Boost Time</p> <p>Program ⇒ Special Control Parameters ⇒ Low Output Disable Function ⇒ LOD Boost Time</p> <p>The Low Output Disable Boost Time sets the on-time timer for the LOD Boost function.</p> <p>Once expired, the LOD Boost function ceases.</p>	<p>Direct Access Number — F735</p> <p>Parameter Type — Numerical</p> <p>Factory Default — 0.0</p> <p>Changeable During Run — Yes</p> <p>Minimum — 0.0</p> <p>Maximum — 3600.0</p> <p>Units — Seconds</p>

<p>LOD Feedback Level (Hz)</p> <p>Program ⇒ Special Control Parameters ⇒ Low Output Disable Function ⇒ LOD Feedback Level (Hz)</p> <p>The Low Output Disable Feedback Level sets a frequency level that, until the output of the ASD drops below this setting, the Restart Delay Timer does not start.</p>	<p>Direct Access Number — F736</p> <p>Parameter Type — Numerical</p> <p>Factory Default — 0.0</p> <p>Changeable During Run — Yes</p> <p>Minimum — 0.0</p> <p>Maximum — Max. Freq.</p> <p>Units — Hz</p>
<p>LOD Restart Delay Time</p> <p>Program ⇒ Special Control Parameters ⇒ Low Output Disable Function ⇒ LOD Restart Delay Time</p> <p>The Low Output Disable Restart Delay Time sets the time that, once expired and all standard ASD requirements are met, normal ASD operation resumes.</p>	<p>Direct Access Number — F737</p> <p>Parameter Type — Numerical</p> <p>Factory Default — 0.0</p> <p>Changeable During Run — Yes</p> <p>Minimum — 0.0</p> <p>Maximum — 3600.0</p> <p>Units — Seconds</p>
<p>Communication Baud Rate (logic)</p> <p>Program ⇒ Communication Setting Parameters ⇒ Communication Settings</p> <p>This parameter plays a role in the setup of the communications network by establishing the Baud Rate of the communications link.</p> <p>The communications network includes other ASDs and Host/Control computers that monitor the status of the ASD(s), transfers commands, and loads or modifies the parameter settings of the ASD.</p> <p>Changes made to this parameter require that the power be cycled (Off then On) for the changes to take effect.</p>	<p>Direct Access Number — F800</p> <p>Parameter Type — Numerical</p> <p>Factory Default — 9600</p> <p>Changeable During Run — Yes</p> <p>Minimum — 1200</p> <p>Maximum — 9600</p> <p>Units — BPS</p>
<p>Parity</p> <p>Program ⇒ Communication Setting Parameters ⇒ Communication Settings</p> <p>This parameter plays a role in the setup of the communications network by establishing the Parity setting of the communications link.</p> <p>The communications network includes other ASDs and Host/Control computers that monitor the status of the ASD(s), transfers commands, and loads or modifies the parameter settings of the ASD.</p> <p>Changes made to this parameter require that the power be cycled (Off then On) for the changes to take effect.</p> <p>Settings:</p> <ul style="list-style-type: none"> No Parity Even Parity Odd Parity 	<p>Direct Access Number — F801</p> <p>Parameter Type — Selection List</p> <p>Factory Default — Even Parity</p> <p>Changeable During Run — Yes</p>

<p>ASD Number</p> <p>Program ⇒ Communication Setting Parameters ⇒ Communication Settings</p> <p>This parameter plays a role in the setup of the communications network by assigning an identification (ID) number to each ASD in the communications network.</p> <p>The communications network includes other ASDs and Host/Control computers that monitor the status of the ASD(s), transfers commands, and loads or modifies the parameter settings of the ASD.</p> <p>Changes made to this parameter require that the power be cycled (Off then On) for the changes to take effect.</p>	<p>Direct Access Number — F802</p> <p>Parameter Type — Numerical</p> <p>Factory Default — 0</p> <p>Changeable During Run — Yes</p> <p>Minimum — 0</p> <p>Maximum — 255</p>
<p>RS232/RS485 Communications Time Out Time</p> <p>Program ⇒ Communication Setting Parameters ⇒ Communication Settings</p> <p>This parameter plays a role in the setup of the communications network by setting the time that no activity may exist over the communications link before the link is severed (Time Out).</p> <p>The communications network includes other ASDs and Host/Control computers that monitor the status of the ASD(s), transfers commands, and loads or modifies the parameter settings of the ASD.</p> <p>Changes made to this parameter require that the power be cycled (Off then On) for the changes to take effect.</p>	<p>Direct Access Number — F803</p> <p>Parameter Type — Numerical</p> <p>Factory Default — 0</p> <p>Changeable During Run — Yes</p> <p>Minimum — 0</p> <p>Maximum — 100</p> <p>Units — Seconds</p>
<p>RS232/RS485 Communications Time-Out Action</p> <p>Program ⇒ Communication Setting Parameters ⇒ Communication Settings</p> <p>This parameter plays a role in the setup of the communications network by determining the action to be taken in the event of a time-out (Time-Out Action).</p> <p>The communications network includes other ASDs and Host/Control computers that monitor the status of the ASD(s), transfers commands, and loads or modifies the parameter settings of the drive.</p> <p>Changes made to this parameter require that the power be cycled (Off then On) for the changes to take effect.</p> <p>Settings:</p> <ul style="list-style-type: none"> No Action Alarm Trip 	<p>Direct Access Number — F804</p> <p>Parameter Type — Selection List</p> <p>Factory Default — Trip</p> <p>Changeable During Run — Yes</p>
<p>Communication Interval</p> <p>Program ⇒ Communication Setting Parameters ⇒ Communication Settings</p> <p>This parameter sets the Common Serial response delay time.</p> <p>Changes made to this parameter require that the power be cycled (Off then On) for the changes to take effect.</p>	<p>Direct Access Number — F805</p> <p>Parameter Type — Numerical</p> <p>Factory Default — 0.00</p> <p>Changeable During Run — Yes</p> <p>Minimum — 0.00</p> <p>Maximum — 2.00</p> <p>Units — Seconds</p>

F806

F810

TTL Master OutputProgram ⇒ Communication Setting Parameters ⇒ **Communication Settings**

In a master/follower configuration, this setting determines the output parameter of the master ASD that will be used to control the applicable follower ASDs.

***Note:** Select **No Follower** if **F826** is configured as a **Master Output** controller. Otherwise, an **EOI** failure will result.*

Changes made to this parameter require that the power be cycled (Off then On) for the changes to take effect.

Settings:

- No Follower (normal operation)
- Frequency Reference
- Output Command Frequency
- Torque Command
- Output Torque Command

Direct Access Number — F806Parameter Type — **Selection List**Factory Default — **No Follower** (normal operation)Changeable During Run — **Yes**

Frequency Point SelectionProgram ⇒ Communication Setting Parameters ⇒ **Communication Reference Adjust**

This parameter enables the communications reference for scaling by selecting an input type.

See **F811** — **F814** for further information on this setting.

***Note:** Scaling the communications signal is not required for all applications.*

Changes made to this parameter require that the power be cycled (Off then On) for the changes to take effect.

Settings:

- Disabled
- Common Serial (TTL)
- RS232/RS485
- Communication Card

Direct Access Number — F810Parameter Type — **Selection List**Factory Default — **Disabled**Changeable During Run — **Yes**

F811

F813

Communications Speed Reference #1

Program ⇒ Communication Setting Parameters ⇒ **Communication Reference Adjust**

When enabled at **F810**, this parameter is used to allow the user to set the gain and bias of the speed control input to the drive when the speed control signal is received via the source selected at **F810**.

Communications Input Speed Control Setup

Perform the following setup to allow the system to receive control input via Communications:

- Set **Communications Speed Reference #1 (F811)** — the input signal that represents **BIN Speed Frequency #1**.
- Set **Communications Speed Frequency #1 (F812)**.
- Set **Communications Speed Reference #2 (F813)** — the input signal that represents **BIN Speed Frequency #2**.
- Set **Communications Speed Frequency #2 (F814)**.
- Provide a **Run** command (**F** and/or **R**).

Once set, as the input signal value changes, the output frequency of the drive will vary in accordance with the above settings.

This parameter sets the **Communications Speed Reference #1** input value that represents **Communications Speed Frequency #1**. This value is entered as 0 to 100% of the **Communications Speed Reference #1** input value range.

Changes made to this parameter require that the power be cycled (Off then On) for the changes to take effect.

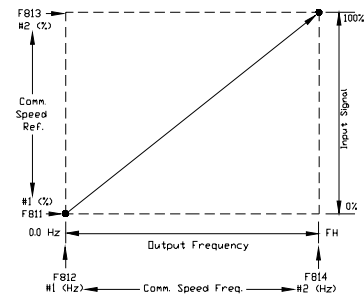
Direct Access Number — F811Parameter Type — **Numerical**Factory Default — **0.00**Changeable During Run — **Yes**Minimum — **0.00**Maximum — **100.0**Units — **%****Communications Speed Frequency #1**

Program ⇒ Communication Setting Parameters ⇒ **Communication Reference Adjust**

This parameter is used to set the gain and bias of the **Communications Reference** speed control input.

See **F811** for further information on this setting.

This parameter sets **Communications Speed Frequency #1** and is the frequency that is associated with the setting of **Communications Speed Reference #1**.

Changes made to this parameter require that the power be cycled (Off then On) for the changes to take effect.

Direct Access Number — F812Parameter Type — **Numerical**Factory Default — **0.00**Changeable During Run — **Yes**Minimum — **0.00**Maximum — **Max. Freq. (F011)**Units — **Hz****Communications Speed Reference #2**

Program ⇒ Communication Setting Parameters ⇒ **Communication Reference Adjust**

This parameter is used to set the gain and bias of the **Communications Speed Reference #2** speed control input.

See **F811** for further information on this setting.

This parameter sets the **Communications Speed Reference #2** input value that represents **Communications Speed Frequency #2**. This value is entered as 0 to 100% of the **Communications Speed Reference #2** input value range.

Changes made to this parameter require that the power be cycled (Off then On) for the changes to take effect.

Direct Access Number — F813Parameter Type — **Numerical**Factory Default — **100.0**Changeable During Run — **Yes**Minimum — **0.00**Maximum — **100.0**Units — **%**

<p>Communications Speed Frequency #2</p> <p>Program ⇒ Communication Setting Parameters ⇒ Communication Reference Adjust</p> <p>This parameter is used to set the gain and bias of the Communications Speed Reference #2 speed control input.</p> <p>See F811 for further information on this setting.</p> <p>This parameter sets Communications Speed Frequency #2 and is the frequency that is associated with the setting of Communications Speed Reference #2.</p> <p>Changes made to this parameter require that the power be cycled (Off then On) for the changes to take effect.</p>	<p>Direct Access Number — F814</p> <p>Parameter Type — Numerical</p> <p>Factory Default — 80.0</p> <p>Changeable During Run — Yes</p> <p>Minimum — 0.0</p> <p>Maximum — Max. Freq. (F011)</p> <p>Units — Hz</p>
<p>RS232/RS485 Baud Rate</p> <p>Program ⇒ Communication Setting Parameters ⇒ Communication Settings</p> <p>This parameter sets the RS232/RS485 baud rate.</p> <p>Changes made to this parameter require that the power be cycled (Off then On) for the changes to take effect.</p> <p>Settings:</p> <ul style="list-style-type: none"> 1200 2400 4800 9600 19200 38400 	<p>Direct Access Number — F820</p> <p>Parameter Type — Selection List</p> <p>Factory Default — 9600</p> <p>Changeable During Run — Yes</p>
<p>RS232/RS485 Wire Count</p> <p>Program ⇒ Communication Setting Parameters ⇒ Communication Settings</p> <p>This parameter sets the communications protocol to the 2 or 4 wire method.</p> <p>Changes made to this parameter require that the power be cycled (Off then On) for the changes to take effect.</p> <p>Settings:</p> <ul style="list-style-type: none"> 2 wire 4 wire 	<p>Direct Access Number — F821</p> <p>Parameter Type — Selection List</p> <p>Factory Default — 4</p> <p>Changeable During Run — Yes</p>
<p>RS232/RS485 Response Delay Time</p> <p>Program ⇒ Communication Setting Parameters ⇒ Communication Settings</p> <p>This parameter sets the RS232/RS485 response delay time.</p> <p>Changes made to this parameter require that the power be cycled (Off then On) for the changes to take effect.</p>	<p>Direct Access Number — F825</p> <p>Parameter Type — Numerical</p> <p>Factory Default — 0.00</p> <p>Changeable During Run — Yes</p> <p>Minimum — 0.00</p> <p>Maximum — 2.00</p> <p>Units — Seconds</p>

F826

F830

RS232/RS485 Master OutputProgram ⇒ Communication Setting Parameters ⇒ **Communication Settings**

In a master/follower configuration, this setting determines the output parameter of the master ASD that will be used to control the applicable follower ASDs.

Note: Select **No Follower** if **F806** is configured as a **Master Output** controller. Otherwise, an **EOI** failure will result.

Changes made to this parameter require that the power be cycled (Off then On) for the changes to take effect.

Settings:

- No Follower (normal operation)
- Frequency Reference
- Output Command Frequency
- Torque Command
- Output Torque Command

Direct Access Number — F826Parameter Type — **Selection List**Factory Default — **No Follower** (normal operation)Changeable During Run — **Yes**

Communication ErrorProgram ⇒ Communication Setting Parameters ⇒ **Communication Error**

In the event of a communication error during a transmission, the command that was transmitted may be cleared or held.

Changes made to this parameter require that the power be cycled (Off then On) for the changes to take effect.

Settings:

- Command Request Cleared
- Command Request Held

Direct Access Number — F830Parameter Type — **Selection List**Factory Default — **Command Request Cleared**Changeable During Run — **Yes**

Alarms, Trips, and Troubleshooting

Alarms and Trips

This section lists the available user-notification codes of the EOI display and provides information that assists the user in the event that a **Fault** is incurred. The **User Notification** codes are displayed as an indication that a system function or system condition is active (i.e., ATN, DB, and DBON). The code is displayed on the EOI for the duration of the activation.

If a user setting or an ASD parameter has been exceeded, or if a data transfer function produces an unexpected result, a condition that is referred to as a **Fault** is incurred.

An **Alarm** is an indication that a **Fault** is imminent if existing operating conditions continue unchanged. An **Alarm** may be associated with an output terminal to notify the operator of the condition remotely, close a contact, or engage a brake. At the least, an **Alarm** will cause an alarm code to appear on the EOI display. [Table 10](#) lists the 16 possible **Alarm** codes that may be displayed during operation of the **H7 ASD**.

In the event that the condition that caused the **Alarm** does not return to its normal operating level within a specified time, the ASD **Faults** and a **Trip** is incurred (**Fault** and **Trip** are sometimes used interchangeably). A **Trip** is a safety feature, and is the result of a **Fault**, that disables the ASD system in the event that a subsystem of the ASD is malfunctioning, or one or more of the variables listed below exceeds its normal range (time and/or magnitude).

- Current,
- Voltage,
- Speed,
- Temperature,
- Torque, or
- Load.

See [Table 12 on pg. 184](#) for a listing of the potential **Trips** and the associated probable causes.

The operating conditions at the time of the trip may be used to help determine the cause of the trip. Listed below are operating conditions that may be used to assist the operator in correcting the problem or that the ASD operator should be prepared to discuss when contacting Toshiba's Customer Support for assistance.

- What trip information is displayed?
- Is this a new installation?
- Has the system ever worked properly and what are the recent modifications (if any)?
- What is the ASD/Motor size?
- What is the CPU version and revision level?
- What is the EOI version?
- Does the ASD trip when accelerating, running, decelerating, or when not running?
- Does the ASD reach the commanded frequency?
- Does the ASD trip without the motor attached?
- Does ASD trip with an unloaded motor?

Alarms

Table 10 lists the alarm codes that may be displayed during operation of the **H7 ASD**. Each alarm code listed is accompanied by a description and a possible cause. In the event that the source of the malfunction cannot be determined, contact your Toshiba Sales Representative for further information on the condition and for an appropriate course of action.

The **Alarms** are listed in the top-down order that they are checked for activation. Only the first to be detected will be displayed on the Frequency Command screen.

Table 10. H7 Alarms.

EOI Display	Function	Description	Possible Causes
CM1	Comm1 Error	Internal communications error.	<ul style="list-style-type: none"> Improperly programmed ASD. Improper communications settings. Improperly connected cables.
CM2	Comm2 Error	External communications error.	
EMG	Emergency Off	Output signal from the ASD is terminated and a brake may be applied if so configured.	<ul style="list-style-type: none"> Stop/Reset pressed twice at the EOI. E OFF command received remotely. ASD reset required.
MOFF	Main Undervoltage	Undervoltage condition at the 3-phase AC input to the ASD.	<ul style="list-style-type: none"> Low 3-phase utility voltage.
OC	Over Current	ASD output current greater than F601 setting.	<ul style="list-style-type: none"> Defective IGBT (U, V, or W). ASD output to the motor is connected incorrectly. Disconnect the motor and retry. ASD output phase-to-phase short. The ASD is starting into a spinning motor. Motor/machine jammed. Mechanical brake engaged while the ASD is starting or while running. Accel/Decel time is too short. Voltage Boost setting is too high. Load fluctuations. ASD operating at an elevated temperature.
*OH	Overheat	ASD ambient temperature excessive.	<ul style="list-style-type: none"> ASD is operating at an elevated temperature. ASD is too close to heat-generating equipment. Cooling fan vent is obstructed (see Mounting the ASD on pg. 18). Cooling fan is inoperative. Internal thermistor is disconnected.
OJ	Timer	Run-time counter exceeded.	<ul style="list-style-type: none"> Type Reset required; select Clear run timer.
* Reset ignored if active.			

EOI Display	Function	Description	Possible Causes
*OLI	ASD Overload	Load requirement in excess of the capability of the ASD.	<ul style="list-style-type: none"> The carrier frequency is too high. An excessive load. Acceleration time is too short. DC damping rate is set too high. The motor is starting into a spinning load after a momentary power failure. The ASD is improperly matched to the application.
OLM	Motor Overload	Load requirement in excess of the capability of the motor.	<ul style="list-style-type: none"> V/f parameter improperly set. Motor is locked. Continuous operation at low speed. The load is in excess of what the motor can deliver.
*OLR	Resistor Overload	Excessive current at the Dynamic Braking Resistor .	<ul style="list-style-type: none"> Deceleration time is too short. DBR configuration improperly set.
*OP	Overtorque	DC bus voltage exceeds specifications.	<ul style="list-style-type: none"> ASD attempting to start into a spinning motor after a momentary power loss. Incoming utility power is above the specified range. Decel time is too short. Voltage spikes at the 3-phase input; install inductive filter. DBR required. DBR resistance value is too high. DBR function is turned off. Overtorque Stall feature is turned off. System is regenerating. Load instability. Disable the Ridethrough function (F302).
OT	Overtorque	Torque requirement in excess of the setting of F616 or F617 for a time longer than the setting of F618 .	<ul style="list-style-type: none"> ASD is not correctly matched to the application. F616 or F617 setting is too low. Obstructed load.
*POFF	Control Undervoltage	Undervoltage condition at the 5, 15, or the 24 VDC supply.	<ul style="list-style-type: none"> Defective Control board. Excessive load on power supply. Low input voltage.
PtSt	Reference Point	Two speed-reference frequency setpoint values are too close to each other.	<ul style="list-style-type: none"> Two speed reference frequency setpoints are too close to each other (increase the difference).
UC	Undercurrent	Output current of the ASD is below the level defined at F611 and remains there for the time set at F612 .	
* Reset ignored if active.			

User Notification Codes

The **User Notification** codes appear in the top right corner of the **Frequency Command** screen while the associated function is active.

User Notification codes notify the user of active functions that are usually only momentary under normal conditions and are active for the duration of activation only. User notification events are not error conditions and only convey active system functions to the user.

Table 11. User Notification codes.

EOI	Function	Description
Atn	Autotune active	Atn indicates that the Autotune function is active. If the initial Autotune fails for any reason, an automatic retry is initiated if Other is selected at F413 . Atn2 indicates that an Autotune retry is active for the duration of the automatic retry.
dbOn	DC Braking	This code conveys the DC Injection function being carried out. The display shows db when braking and shows dbOn when the motor shaft stationary function is being carried out.

Trips/Faults

A **Trip** is an ASD response to a **Fault** (though, **Fault** and **Trip** are sometimes used interchangeably). A **Trip** is a safety feature that disables the ASD system in the event that a subsystem of the ASD is malfunctioning.

Listed in [Table 12](#) are the possible **Faults** that may cause a **Trip** and the possible causes. When a **Trip** is incurred the system displays the **Fault** screen. The **Fault** screen identifies the active **Fault**.

Table 12

Fault Screen Display	Possible Causes
ASD Overload	<ul style="list-style-type: none"> Acceleration time is too short. DC Injection current is too high. V/f setting needs to be adjusted. Motor running during restart. ASD or the motor is improperly matched to the application.
Autotune Error	<ul style="list-style-type: none"> Autotune readings that are significantly inconsistent with the configuration information. A non-3-phase motor is being used. Incorrect settings at F400, F413, or F414. Using a motor that has a significantly smaller rating than the ASD. ASD output cabling is too small, too long, or is being housed in a cable tray with other cables that are producing an interfering EMF. Motor is running during the Autotune function.
Communication Error	<ul style="list-style-type: none"> Communication malfunction. Improper or loose connection. Improper system settings.
Control Power Undervoltage	<ul style="list-style-type: none"> This fault is caused by an undervoltage condition at the 5, 15, or the 24 VDC supply. 3-phase input voltage low.

Fault Screen Display	Possible Causes
CPU Fault	<ul style="list-style-type: none"> • CPU malfunction.
DC Bus Undervoltage	<ul style="list-style-type: none"> • 3-phase input voltage low. • Defective control board. • Excessive load on the power supply. • Undervoltage/Ridethrough settings require adjustment.
DC Fuse Open	<ul style="list-style-type: none"> • Internal DC bus fuse is open.
Dynamic Braking Resistor Overcurrent	<ul style="list-style-type: none"> • ASD inability to discharge the bus voltage during regeneration. • No dynamic braking resistor (DBR) installed. • Deceleration time is too short. • Improper DBR setup information. • Defective IGBT7 (or IGBT7 ckt.). • 3-phase input voltage is above specification.
Dynamic Braking Resistor Overload	<ul style="list-style-type: none"> • Deceleration time is too short. • DBR setting adjustment required. • Overvoltage Stall setting adjustment required.
Earth Fault	<ul style="list-style-type: none"> • Ground fault at the motor. • Ground fault at the output of the ASD. • Current leakage to Earth Ground.
EEPROM Data Fault	<ul style="list-style-type: none"> • EEPROM read malfunction.
EEPROM Fault	<ul style="list-style-type: none"> • EEPROM write malfunction.
Emergency Off	<ul style="list-style-type: none"> • Emergency Off command received via EOI or remotely.
Encoder Loss	<ul style="list-style-type: none"> • Encoder signal missing while running during closed-loop operation.
Flash Memory Fault	<ul style="list-style-type: none"> • Flash memory malfunction.
Gate Array Fault	<ul style="list-style-type: none"> • Defective Gate Array or Gate Array malfunction.
Input Phase Loss	<ul style="list-style-type: none"> • 3-phase input to the ASD is low or missing.
Load Drooping	<ul style="list-style-type: none"> • Load requirement is in excess of the capabilities of the motor.
Load End Short Circuit	<ul style="list-style-type: none"> • Improper wiring at the ASD output to the motor.
Low Current	<ul style="list-style-type: none"> • Improper Low Current detection level setting.
Main Board EEPROM Fault	<ul style="list-style-type: none"> • Internal EEPROM malfunction.
Motor Overload	<ul style="list-style-type: none"> • V/f setting needs to be adjusted. • Motor is locked. • Continuous operation at low speed. • Load requirement exceeds ability of the motor. • Startup frequency setting adjustment required.
No Fault	<ul style="list-style-type: none"> • No active faults.
<p>Note: The event that caused the Trip(s) must be corrected or must decrease to less than the threshold value required to cause the trip to allow for a Reset to be recognized. In the event of multiple active trips, the trip displayed will remain until all faults are corrected and all trips are cleared.</p>	

Fault Screen Display	Possible Causes
Option Fault	<ul style="list-style-type: none"> • Optional device malfunction. • Improper system settings (at ASD or optional device). • Loose or improper connection.
Output Current Protection Fault	<ul style="list-style-type: none"> • Output current is not within specified limits. • Loose or improper ASD-to-motor connection.
Output Phase Loss	<ul style="list-style-type: none"> • 3-phase output from the ASD is low or missing.
Overcurrent During Acceleration	<ul style="list-style-type: none"> • V/f setting needs to be adjusted. • Restart from a momentary power outage. • The ASD is starting into a rotating motor. • ASD/Motor not properly matched. • Phase-to-phase short (U, V, or W). • Accel time too short. • Voltage Boost setting is too high. • Motor/machine jammed. • Mechanical brake engaged while the ASD is running. • ASD current exceeds 340% of the rated FLA on ASDs that are 100 HP or less during acceleration. On ASDs that are greater than 100 HP, this fault occurs when the ASD current exceeds 320% of the rated FLA during acceleration.
Overcurrent During Deceleration	<ul style="list-style-type: none"> • Phase-to-phase short (U, V, or W). • Deceleration time is too short. • Motor/machine jammed. • Mechanical brake engaged while the ASD is running. • ASD current exceeds 340% of the rated FLA on ASDs that are 100 HP or less during deceleration. On ASDs that are greater than 100 HP, it occurs when the ASD current exceeds 320% of the rated FLA during deceleration.
Overcurrent During Run	<ul style="list-style-type: none"> • Load fluctuations. • ASD is operating at an elevated temperature. • ASD current exceeds 340% of the rated FLA on ASDs that are 100 HP or less during a fixed-speed run or if during a fixed-speed run the ASD overheats. On ASDs that are greater than 100 HP, it occurs when the ASD current exceeds 320% of the rated FLA on a fixed-speed run.
Overheat	<ul style="list-style-type: none"> • Cooling fan inoperative. • Ventilation openings are obstructed. • Internal thermistor is disconnected.
Over Speed	<ul style="list-style-type: none"> • Result of a motor speed that is greater than the commanded speed when using an encoder for speed control. • Improper encoder connection or setup information. • Defective encoder.
<p>Note: The event that caused the Trip(s) must be corrected or must decrease to less than the threshold value required to cause the trip to allow for a Reset to be recognized. In the event of multiple active trips, the trip displayed will remain until all faults are corrected and all trips are cleared.</p>	

Fault Screen Display	Possible Causes
Overtorque	<ul style="list-style-type: none"> • A torque requirement by the load in excess of the setting of F616 or F617 for a time longer than the setting of F618. • The ASD is improperly matched to the application. • The load is obstructed.
Overvoltage During Acceleration	<ul style="list-style-type: none"> • Motor running during restart.
Overvoltage During Deceleration	<ul style="list-style-type: none"> • Deceleration time is too short. • DBR value is too high. • DBR required (DBR setup required). • Stall protection is disabled. • 3-phase input voltage is out of specification. • Input reactance required.
Overvoltage During Run	<ul style="list-style-type: none"> • Load fluctuations. • 3-Phase input voltage out of specification.
PG Type/Connection Error	<ul style="list-style-type: none"> • ASD is configured to receive a signal from a shaft-mounted encoder and no signal is being received while running. • Disconnection at the Encoder circuit. • Motor is stopped and is generating torque via torque limit control. • ASD is not configured properly.
Phantom Fault	<ul style="list-style-type: none"> • In a multiple ASD configuration a faulted ASD signals the remaining ASDs that a fault has occurred and shuts down the non-faulted ASDs.
Position Deviation Error	<ul style="list-style-type: none"> • Operating in the Position Control mode and the resulting position exceeds the limits of the F631 setting.
RAM Fault	<ul style="list-style-type: none"> • Internal RAM malfunction.
ROM Fault	<ul style="list-style-type: none"> • Internal ROM malfunction.
Sink/Source Setting Error	<ul style="list-style-type: none"> • Improperly positioned Sink/Source jumper on the control board or on an option device. • Sink/Source configuration of an option device is incorrect.
Torque Proving Fault	<ul style="list-style-type: none"> • Lift-First Pulse Count (F743) adjustment required.
Typeform Error	<ul style="list-style-type: none"> • Firmware information (typeform) loaded into the Gate Driver board is inconsistent with the device in which the firmware is being used. • The Gate Driver board has been replaced. • The Gate Driver board is defective.
U Phase Short Circuit	<ul style="list-style-type: none"> • Low impedance at the U lead of the ASD output.
V Phase Short Circuit	<ul style="list-style-type: none"> • Low impedance at the V lead of the ASD output.
W Phase Short Circuit	<ul style="list-style-type: none"> • Low impedance at the W lead of the ASD output.
<p>Note: <i>The event that caused the Trip(s) must be corrected or must decrease to less than the threshold value required to cause the trip to allow for a Reset to be recognized. In the event of multiple active trips, the trip displayed will remain until all faults are corrected and all trips are cleared.</i></p>	

Viewing Trip Information

In the event that the condition causing an **Alarm** does not return to the normal operating level within a specified time, the ASD **Faults** and a **Trip** is incurred.

When a trip occurs, the resultant error information may be viewed either from the **Trip History** screen (Program ⇒ Monitor Setup ⇒ **Trip History**), the **Trip Monitor from ASD** screen (Program ⇒ Monitor Setup ⇒ **Trip Monitor From ASD**), or from the **Monitor** screen.

Trip History

The **Trip History** screen records the system parameters for up to 101 trips (RTC option required). The recorded trips are numbered from zero to 100. Once the **Trip History** record reaches trip number 100, the oldest recorded trip will be deleted with each new record stored (first-in first-out). The **Trip #** field may be selected and scrolled through to view the recorded trip information for a given trip number. The monitored parameters are listed in [Table 13](#) as **At-trip Recorded Parameters** (parameter readings at the time that the trip occurred).

Table 13. Trip History Record Parameters (RTC option required).

At-trip Recorded Parameters			
Trip records that are assigned zero and one are comprised of the full list of monitored parameters (32). Trip records 2 – 18 are comprised of parameters 1 – 16. Trip records 19 – 100 are comprised of parameters 1 – 7.			
1) Trip Number	9) Bus Voltage	17) Torque Reference	25) ASD Load
2) Trip Type	10) Discrete Input Status	18) Torque Current	26) DBR Load
3) Time and Date	11) OUT1/OUT2/FL Status	19) Excitation Current	27) Input Power
4) Frequency at Trip	12) Timer	20) PID Value	28) Output Power
5) Output Current	13) Post Compensation Frequency	21) Motor Overload	29) Peak Current
6) Output Voltage	14) Feedback (inst.)	22) ASD Overload	30) Peak Voltage
7) Direction	15) Feedback (1 sec.)	23) DBR Overload	31) PG Speed
8) Frequency Reference	16) Torque	24) Motor Load	32) PG Position

Trip Monitor From ASD

The **Trip Monitor From ASD** function records the trip name of up to four trips and catalogs each trip as **Most Recent**, **Second Most Recent**, **Third Most Recent**, and **Fourth Most Recent**. Once reset (**Clear Trip**), the trip records are erased. If no trips have occurred since the last reset, **No Fault** is displayed for each trip record.

Note: An improper ASD setup may cause some trips — reset the ASD to the **Factory Default** settings before pursuing a systemic malfunction (Program ⇒ Utility Parameters ⇒ Type Reset ⇒ **Restore Factory Defaults**).

Trip Record at Monitor Screen

The at-trip condition of the last incurred trip may be viewed at the **Monitor** screen (see [pg. 46](#)). The **Monitor** screen at-trip record is erased when the ASD is reset and may be viewed without the use of the RTC option.

Clearing a Trip

Once the cause of the trip has been corrected, performing a **Reset** re-enables the ASD for normal operation.

The record of a trip may also be cleared using either of the following methods:

- Cycling power (trip info may be saved via **F602** if desired),
- Pressing the **Stop|Reset** key twice,
- Remotely via the communications channel,
- Momentarily connecting terminal **RES** to **CC** of the **Control Terminal Strip**, or
- Via Program ⇒ Utility Parameters ⇒ Type Reset ⇒ **Clear Trip** (clears **Trip Monitor From ASD**).

Enclosure Dimensions and Conduit Plate Information

H7 ASD Part Numbering Convention.

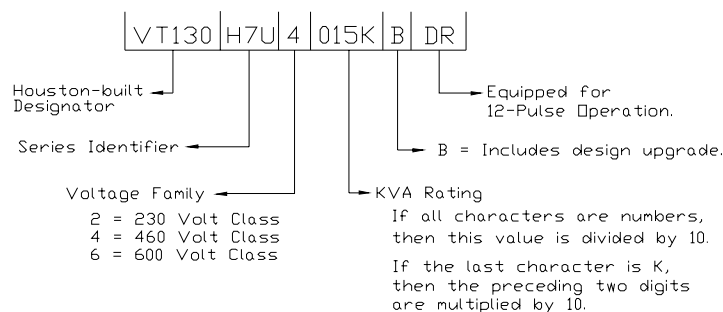

Note: The Type 1 enclosed versions of these drives meet or exceed the specification **UL 1995, the Standard for Heating and Cooling Equipment**, and complies with the applicable requirements for installation in a compartment handling conditioned air. The equipment listed in this manual meets or exceeds the criteria for CE certification and carries the CE label.

Note: For CE compliance, all Toshiba ASD enclosures with hinged doors shall have a lock placed on the standard door fastener or be fitted with the Toshiba lock kit (P/N 53730).

Note: All Toshiba ASD enclosures carry an IP20 rating.

Enclosure Dimensions/Weight

Table 14.

Model Number VT130H7U	Fig.	A (in/mm)	B (in/mm)	C (in/mm)	D (in/mm)	E (in/mm)	F (in/mm)	G (in/mm)	H (in/mm)	Conduit Plate/Box Number (see pg. 195 and 196)		Shipping Weight (lbs.)
										Bottom	Top	
2035B	23	8.47/215	7.28/185	7.33/186	8.47/215	7.95/202	6.74/171	0.53/13	0.23/6	49462	N/A	12
2055B												
2080B												
2110B		14.22/361	12.16/309	11.23/285	14.22/361	13.05/331	11.46/291	0.55/14	0.28/7	49033	N/A	48
2160B												50
2220B												52
2270B												53
2330B	15.72/399	17.5/445	12.81/325	22.33/567	23.75/603	14.25/362	0.75/19	0.38/10	49932	N/A	54	
2400B	157											
2500B	167											
2600B	24	27.53/699							57319-GRY			

Table 14. (Continued)

Model Number VT130H7U	Fig.	A (in/mm)	B (in/mm)	C (in/mm)	D (in/mm)	E (in/mm)	F (in/mm)	G (in/mm)	H (in/mm)	Conduit Plate/Box Number (see pg. 195 and 196)		Shipping Weight (lbs.)	
										Bottom	Top		
2750B	24	38.63/981	17.5/445	13.78/350	36.35/923	37.75/959	12.63/321	0.75/19	0.63/16	49900	49468	261	
210KB												264	
212KB	25	50.00/1270	24.15/613	20.00/508	46.15/1172	48.50/1232	12.00/305	0.75/19	0.69/18	54086	54086	463	
215KB												472	
4055B	23	8.47/215	7.28/185	7.33/186	8.47/215	7.95/202	6.74/171	0.53/13	0.23/6	49462	N/A	13	
4080B												15	
4110B												50	
4160B		14.22/361	12.16/309	11.23/285	14.22/361	13.05/331	11.46/291	0.55/14	0.28/7	49033	N/A	52	
4220B												53	
4270B												54	
4330B												58	
4400B		24	24.63/625	17.5/445	12.81/325	22.33/567	23.75/603	14.25/362	0.75/19	0.38/10	50097	N/A	121
4600B													147
4750B													157
410KB	24	26.47/672	17.5/445	12.81/325	22.33/567	23.75/603	14.25/362	0.75/19	0.38/10	49932	N/A	167	
412KB												167	
415KB	24	38.63/981	17.5/445	13.78/350	36.35/923	37.75/959	12.63/321	0.75/19	0.63/16	49900	49468	261	
420KB												265	
425KB	25	50.00/1270	24.15/613	20.00/508	46.15/1172	48.50/1232	12.00/305	0.75/19	0.69/18	54086	54086	463	
430KB												472	
435KB												493	
440KB												665	
6035B	23	8.47/215	7.28/185	7.33/186	8.47/215	7.95/202	6.74/171	0.53/13	0.23/6	49462	N/A	13	
6060B												50	
6080B												52	
6120B		14.22/361	12.16/309	11.23/285	14.22/361	13.05/331	11.46/291	0.55/14	0.28/7	49033	N/A	54	
6160B												56	
6220B												58	
6270B												58	
6330B		24	24.63/625	17.5/445	12.81/325	22.33/567	23.75/603	14.25/362	0.75/19	0.38/10	50097	N/A	121
6400B													147
6500B													157

Table 14. (Continued)

Model Number VT130H7U	Fig.	A (in/mm)	B (in/mm)	C (in/mm)	D (in/mm)	E (in/mm)	F (in/mm)	G (in/mm)	H (in/ mm)	Conduit Plate/Box Number (see pg. 195 and 196)		Shipping Weight (lbs.)
										Bottom	Top	
6600B	24	24.63/625	17.5/445	12.81/325	22.33/567	23.75/603	14.25/362	0.75/19	0.38/10	50097	N/A	155
6750B												
610KB												
612KB												
615KB												
620KB	25	50.00/1270	24.15/613	20.00/508	46.15/1172	48.50/1232	12.00/305	0.75/19	0.69/18	54086	54086	466
625KB												475
630KB												490
635KB												

Figure 23.

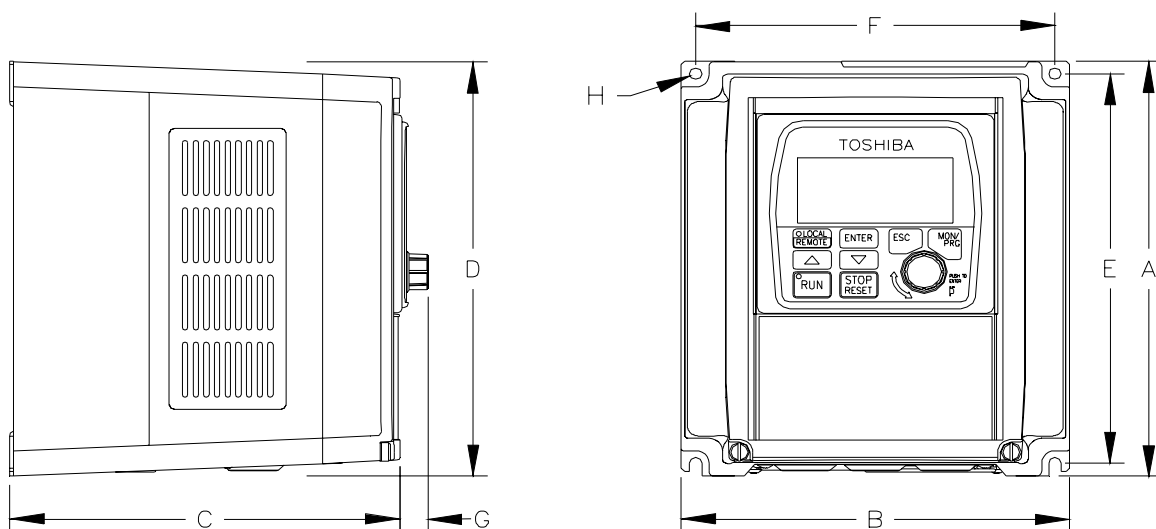

Figure 24.

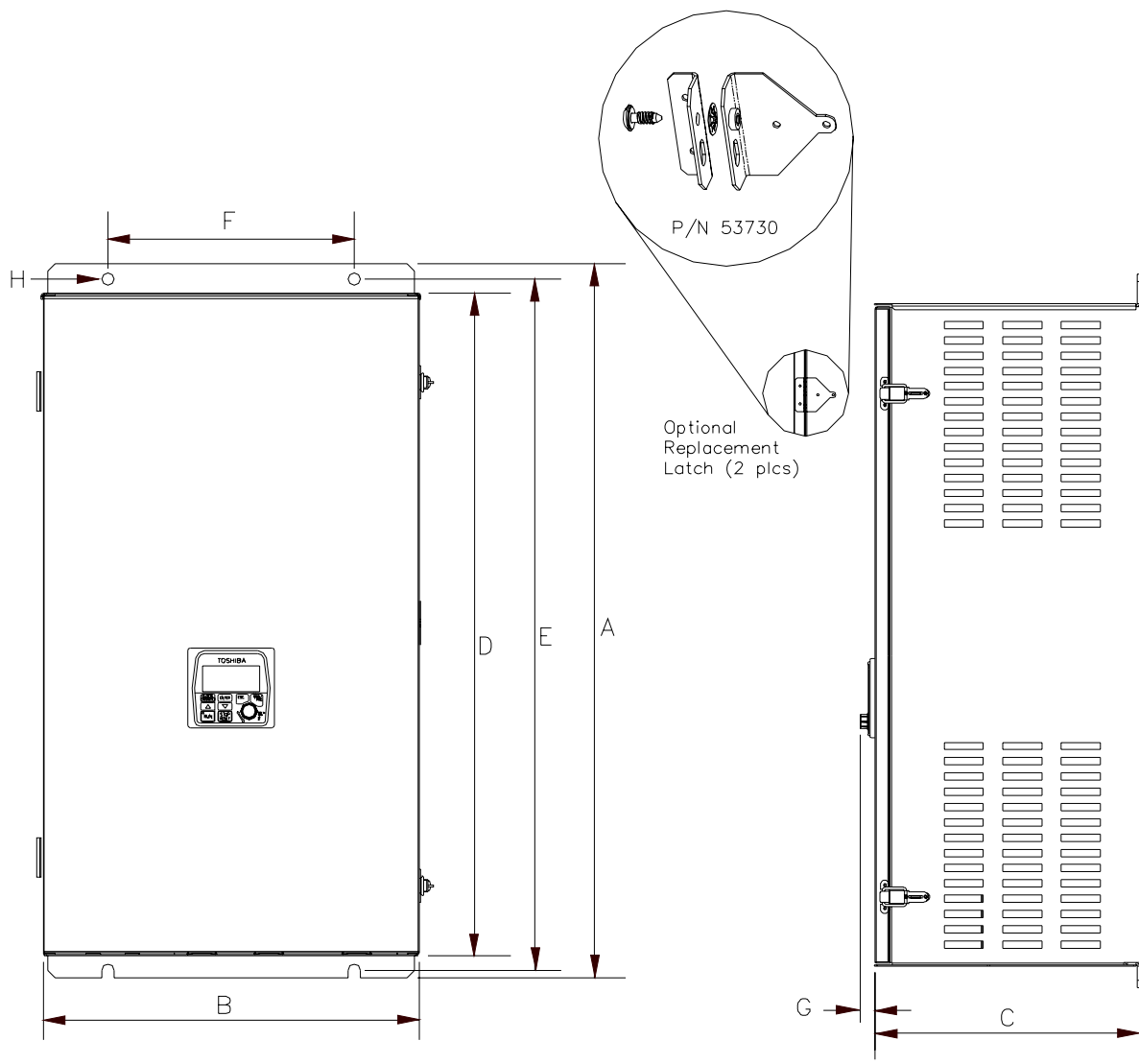
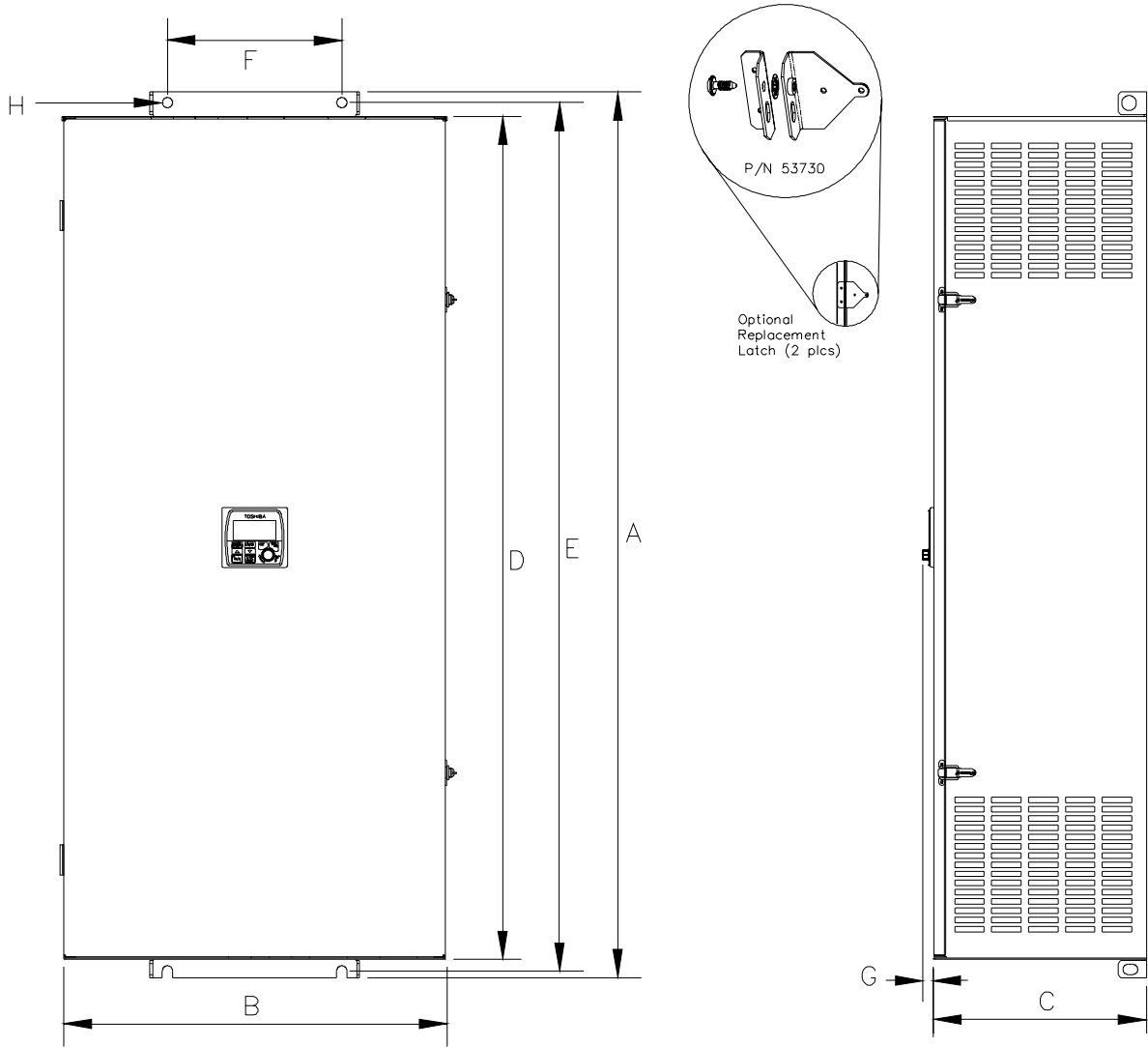

Figure 25.



Conduit Plate Information

The conduit plate information provided below is for the 0.75 to 350 HP **H7 ASDs** of the 230, 460, and 600 volt product lines. Each bottom or top conduit plate may be cross referenced to the applicable device using the information in [Table 14 on page 190](#).

Note: Unless otherwise specified, all dimensions are in inches.

Figure 26.

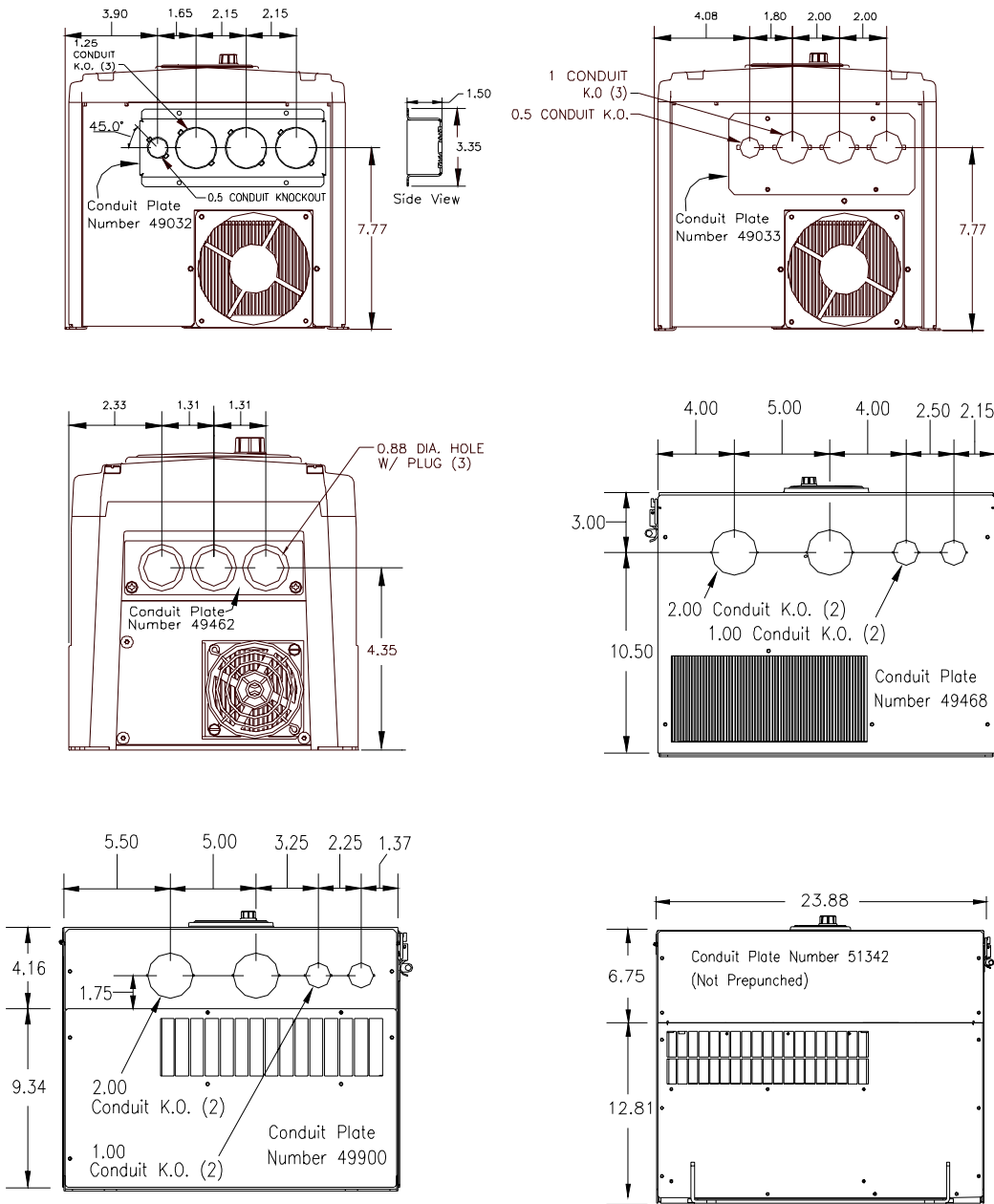
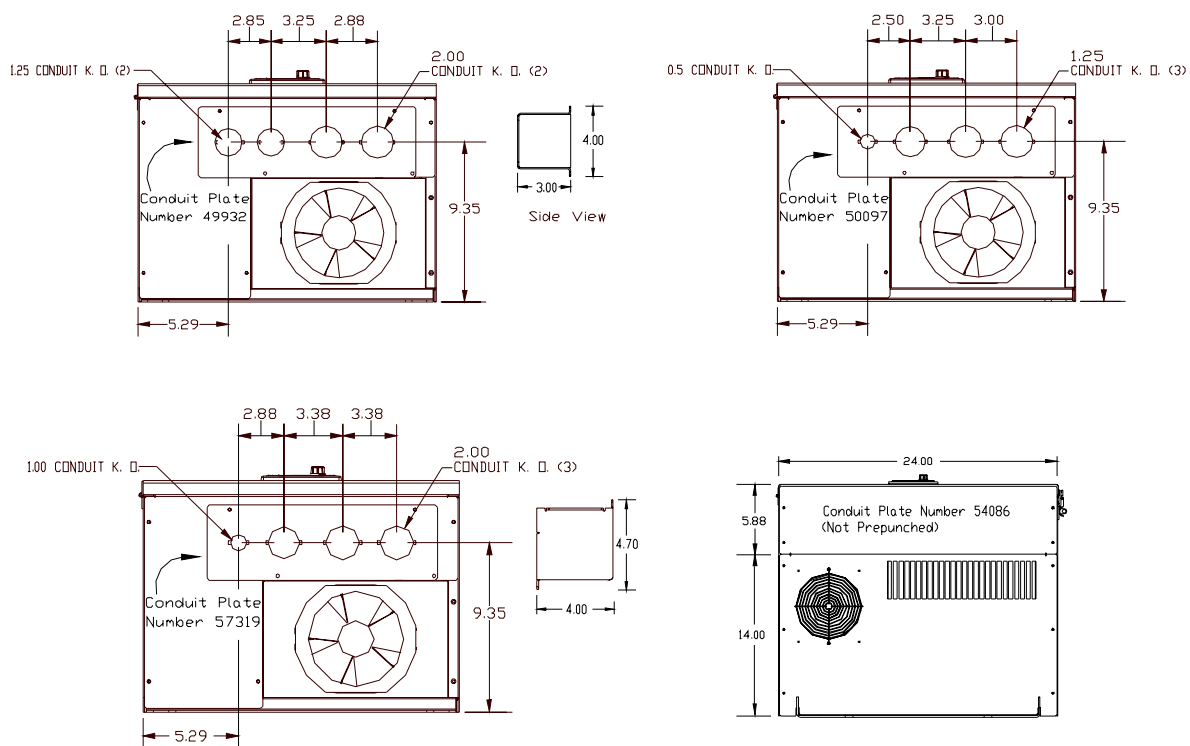

Figure 27.



Conduit Extender Box (option)

The Conduit Extender Box (P/N ASD-Conduit-1) may be used when more room is required at the ASD conduit connection point. This option makes adding and removing conduit easier and quicker.

Installation

1. Remove the conduit plate 49462 (see [Figure 28](#)).
2. Install the Conduit Extender Box 53354 (see [Figure 29](#)) — secure the box using the 2 screws from the conduit plate.
3. Make the conduit and wiring connections.
4. Install the Conduit Extender Box cover 53355 (see [Figure 29](#)).

Figure 28

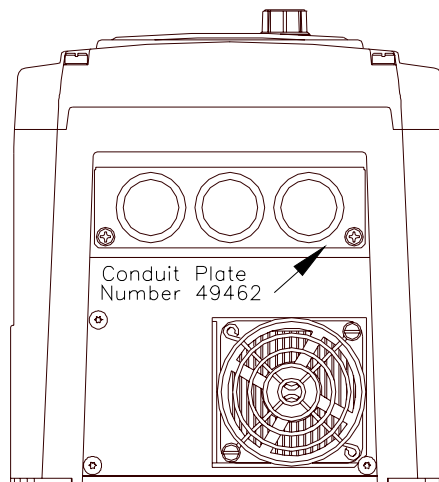
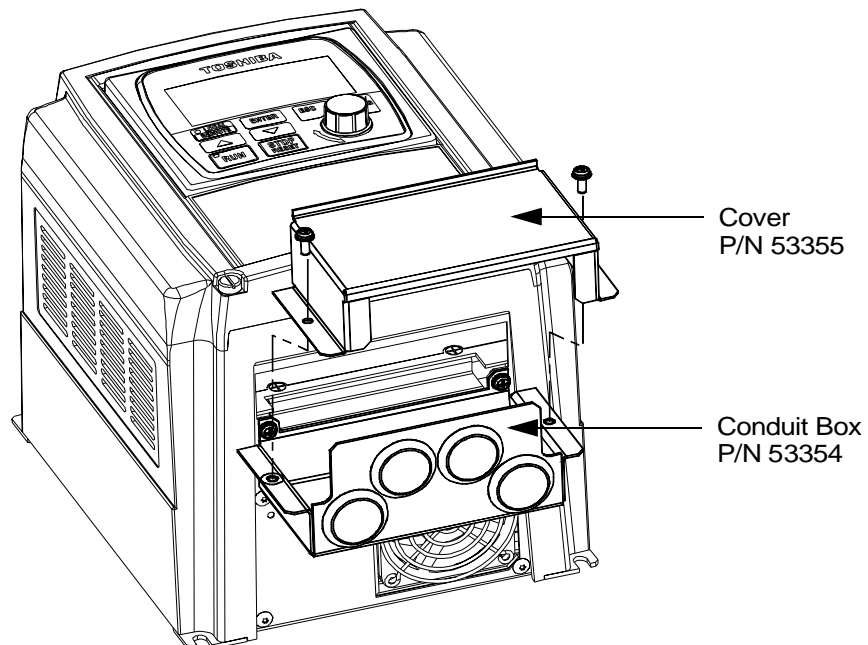

Figure 29. Conduit Extender Box.



H7 ASD Adapter Mounting Plates

The optional H7 ASD mounting plates may be used when replacing a G3 ASD with the **H7 ASD**. The mounting plates are fitted with permanently attached nuts for securing the **H7 ASD** to the adapter plate. The perimeter mounting-hole dimensions of the adapter plate allow the adapter plate to be mounted using the existing cabinet (or wall) holes.

Listed below are the device types that require an adapter plate and their associated adapter plate. The adapter plate dimensions are shown on [pg. 199 – 201](#).

Note: Units not listed do not require an adapter plate.

H7 ASD Model	Adapter Plate Number	H7 ASD Model	Adapter Plate Number
2035	51761	2080	51762
2055		4110	
4055		2270	
4080	51763	2330	51764
2110		4330	
2160		4400	
2220		4500	
4160		6160	
4220		4600	51769
4270		6120	51770
6060		—	—

ASD Adapter Mounting Plate Dimensions

Figure 30. 51761 and 51762 adapter mounting plate dimensions.

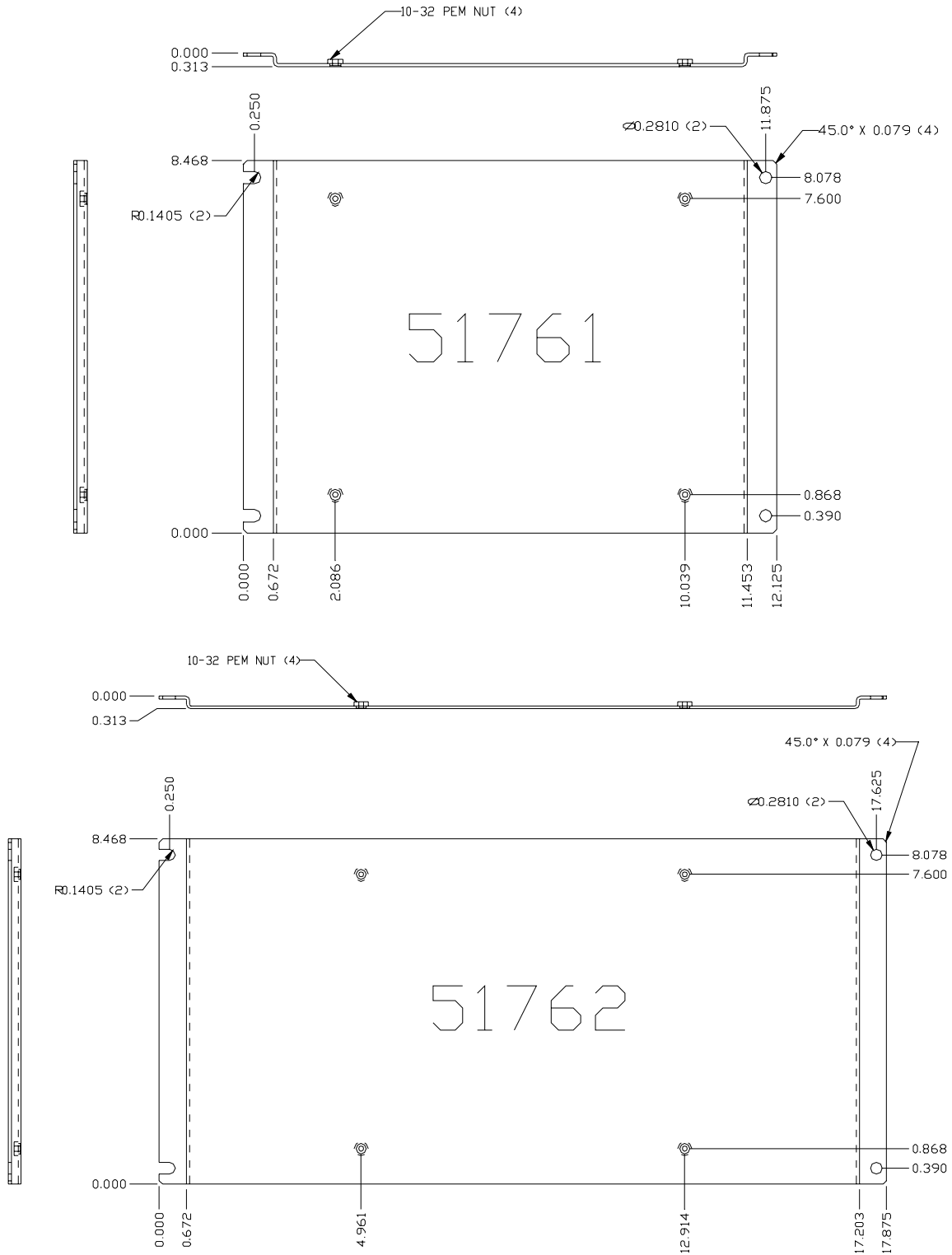

Figure 31. 51763 and 51764 adapter mounting plate dimensions.

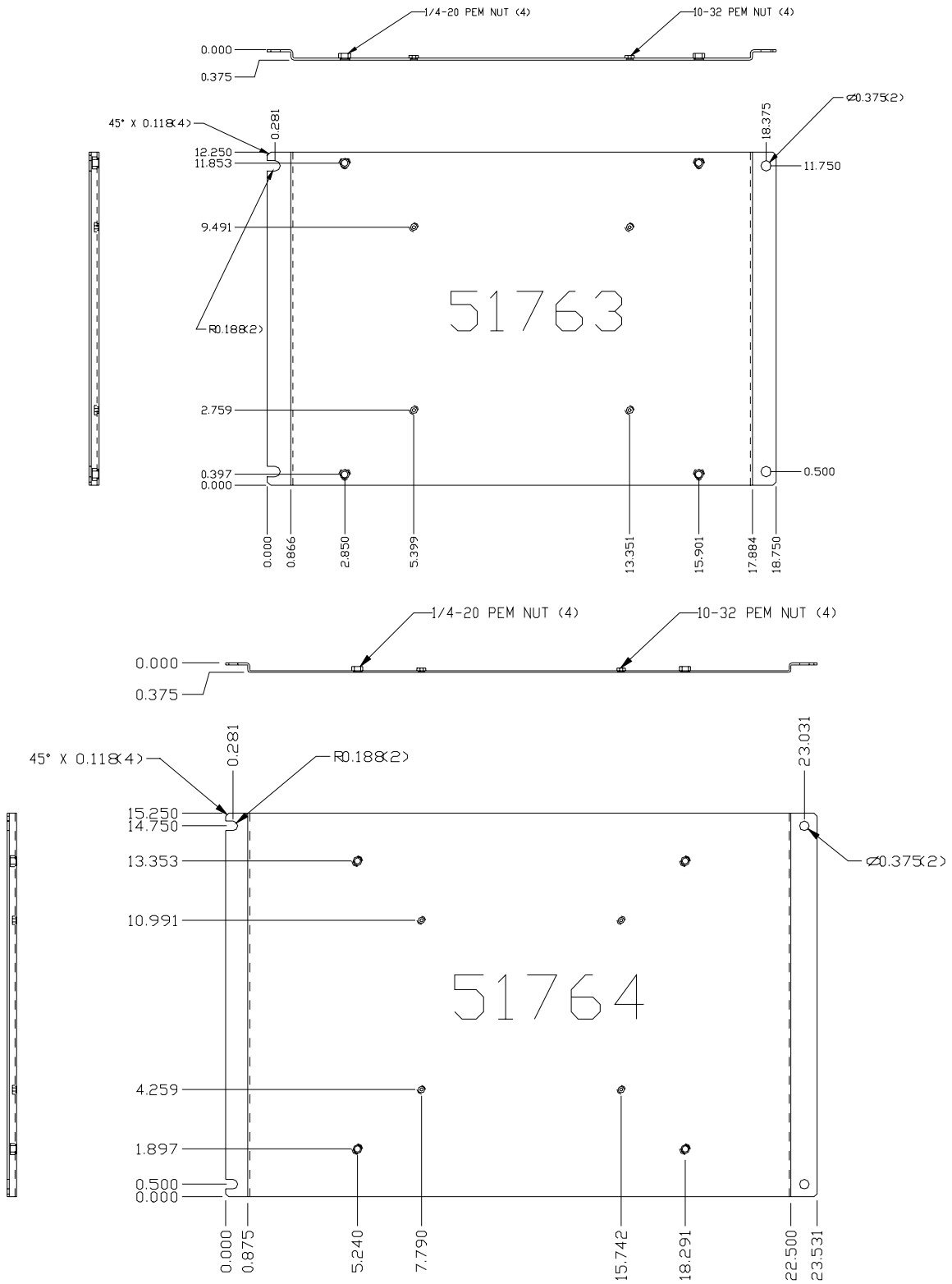
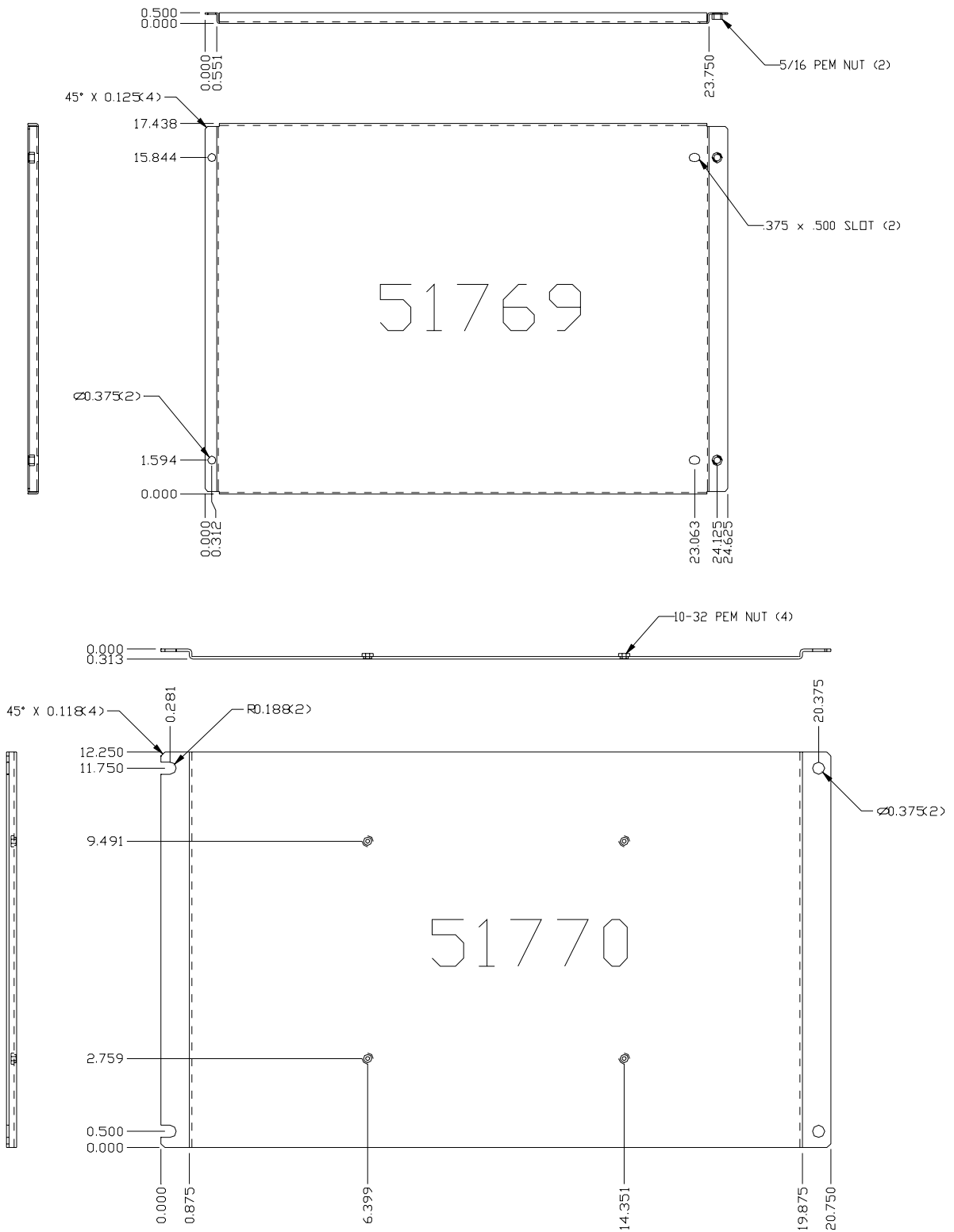

Figure 32. 51769 and 51770 adapter mounting plate dimensions.



EOI Remote Mounting

The H7 ASD may be controlled from a remote position via the EOI. For safety and application-specific reasons, some ASD installations will warrant that the operator not be in the vicinity during operation or that the EOI not be attached to the ASD housing. The EOI may be mounted either with or without the optional H7 ASD Remote Mounting Kit (P/N ASD-MTG-KIT). The ease of installation is enhanced by the H7 ASD Remote Mounting Kit which allows for easier cable routing and EOI placement.

The EOI may be mounted up to 15 feet away from the ASD and will provide the full range of functions that are available if the EOI were ASD-mounted.

Remote mounting will also allow for multiple EOI mountings at one location or one EOI may be switched between multiple ASDs. Controlling and monitoring several ASDs via an EOI may be accomplished from a central location.

The optional dust cover (P/N ASD-BPC) may be used to cover the front panel opening of the ASD housing after removing the EOI. An EOI extender cable is required for remote mounting. EOI extender cables are available in lengths of 7, 10, or 15 feet and may be ordered through your sales representative.

Remote EOI Required Hardware

EOI Mounting Hardware

- 6-32 x 5/16" Pan Head Screw — P/N 50595 (4 ea.)
- #6 Split-Lock Washer — P/N 01884 (4 ea.)
- #6 Flat Washer — P/N 01885 (4 ea.)

Bezel Plate Mounting Hardware

- Bezel Plate — P/N 52291
- 10-32 Hex Nut — P/N 01922 (4 ea.)
- #10 Split-Lock Washer — P/N 01923 (4 ea.)
- #10 Flat Washer — P/N 01924 (4 ea.)
- Dust Cover — P/N ASD-BPC (Optional)

Extender Cables

- ASD-CAB7F: ASD, OPN, H7, EOI, Cable, RJ45, 7 ft.
- ASD-CAB10F: ASD, OPN, H7, EOI, Cable, RJ45, 10 ft.
- ASD-CAB15F: ASD, SPN, H7, EOI, Cable, RJ45, 15 ft.

EOI Installation Precautions

Install the unit securely in a well ventilated area that is out of direct sunlight using the four mounting holes of the EOI. The ambient temperature rating for the EOI is 14 to 104° F (-10 to 40° C).

- Select a mounting location that is easily accessible by the user.
- Avoid installation in areas where vibration, heat, humidity, dust, metal particles, or high levels of electrical noise (EMI) are present.
- Do not install the EOI where it may be exposed to flammable chemicals or gasses, water, solvents, or other fluids.
- Turn the power on only after securing the front cover to the ASD.

EOI Remote Mounting w/o the ASD-MTG-KIT

Note: See [Figure 33](#) for the dimensions and the item locations referenced in steps 1 through 5.

1. At the EOI mounting location, identify and mark the location of the 3.80" by 3.29" hole and the 7/32" screw holes.
2. Cut the 3.80" by 3.29" rectangular hole.
3. Drill the four 7/32" screw holes.
4. Attach and secure the EOI to the front side of the mounting location using the four 6-32 x 5/16" pan head screws, the #6 split lock washers, and the #6 flat washers.
5. Connect the RJ-45 extension cable(s).

EOI Dimensions (mounting)

Figure 33. EOI Mounting Dimensions.

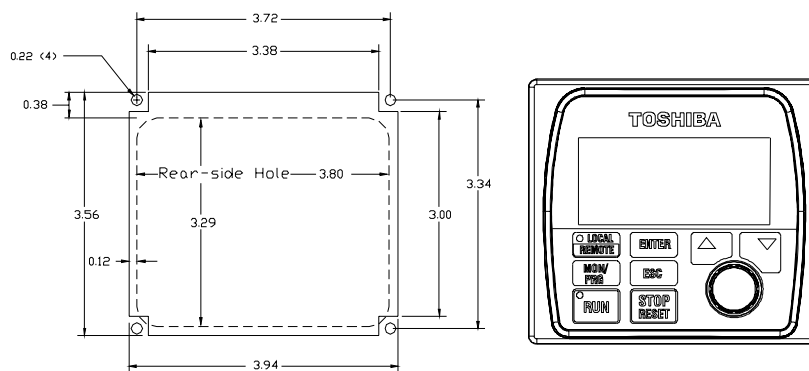

EOI Remote Mounting using the ASD-MTG-KIT

Note: See [Figures 34](#) and [35](#) for the dimensions and the item locations referenced in steps 1 through 6.

1. At the EOI mounting location, identify and mark the locations of the 5.00" by 4.60" hole and the four 11/32" screw holes.
2. Cut the 5.00" by 4.60" rectangular hole.
3. Drill the four 11/32" holes.
4. Attach and secure the Bezel plate to the front side of the mounting location using the four 10-32 hex nuts, #10 split lock washers, and the #10 flat washers.
5. Attach and secure the EOI to the front side of the Bezel plate using the four 6-32 x 5/16" pan head screws, #6 split lock washers, and the #6 flat washers.
6. Connect the RJ-45 extension cable(s).

EOI ASD-MTG-KIT Dimensions (mounting)

Figure 34. EOI Bezel Plate Mounting Dimensions.

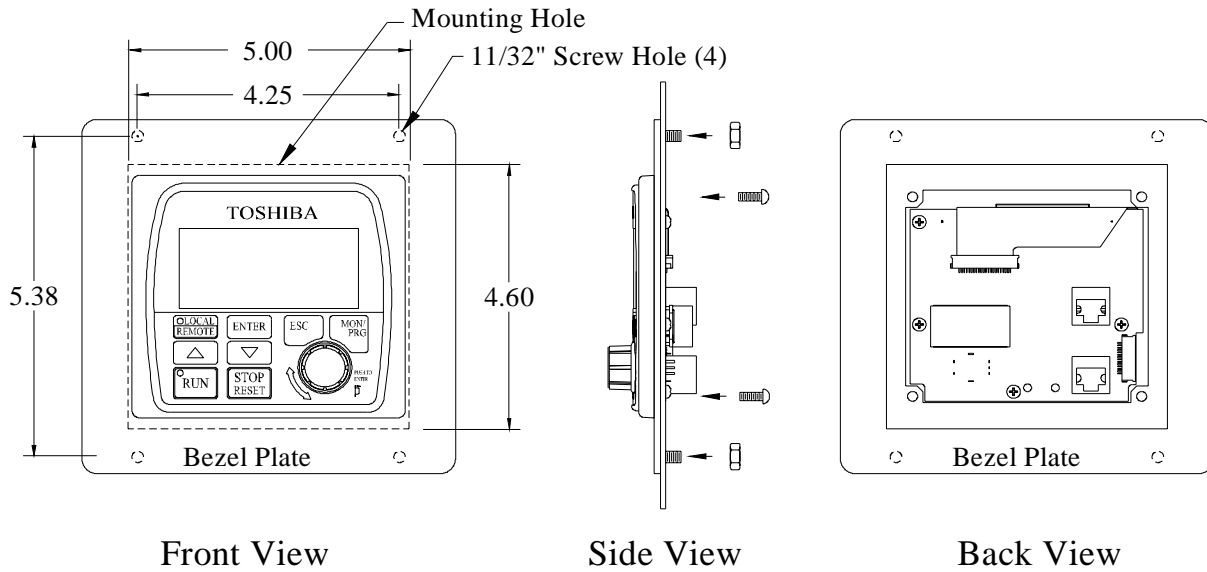
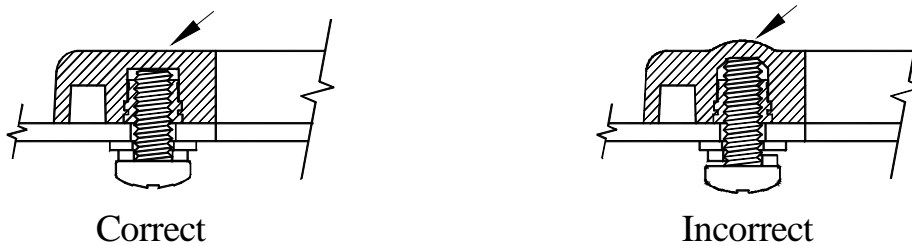

Figure 35. Screw Length Precaution.

CAUTION: Failure to use the correct hardware may result in damage to the outer surface of the EOI panel and/or improper seating of the panel to the bezel plate. Use caution when mounting the EOI assembly to ensure that the internal thread clearance is maintained.



Current/Voltage Specifications

Table 15. 230 Volt NEMA Type-1 Chassis standard ratings table.

Model VT130H7U	Rated KVA	Motor HP/Kw	Input Voltage 3-Ph 50/60 ± 2 Hz	Output Voltage 3-Ph Variable Frequency	Output Current 100% Continuous	Overload Current 120% for 60 Secs.
2035B	3.5	3.0/2.2	200 – 240 VAC (±10%)	Input Voltage Level (Max.)	10.0 A	12.0 A
2055B	5.5	5.0/3.7			16.0 A	19.2 A
2080B	8.0	7.5/5.6			23.0 A	27.6 A
2110B	11.0	10/7.5			30.0 A	36.0 A
2160B	16.0	15/11.2			45.0 A	54.0 A
2220B	22.0	20/14.9			60.0 A	72.0 A
2270B	27.0	25/18.6			71.0 A	85.2 A
2330B	33.0	30/22.4			85.0 A	102.0 A
2400B	40.0	40/30.0			114.0 A	136.8 A
2500B	50.0	50/37.0			130.0 A	156.0 A
2600B	60.0	60/44.4			156.0 A	187.2 A
2750B	75.0	75/55.5			192.0 A	230.4 A
210KB	100	100/74			248.0 A	297.6 A
212KB	125	125/92.5			312.0 A	374.4 A
215KB	150	150/111	370.0 A	444.0 A		

Table 16. 460 Volt NEMA Type-1 Chassis standard ratings table.

Model VT130H7U	Rated KVA	Motor HP/Kw	Input Voltage 3-Ph 50/60 ± 2 Hz	Output Voltage 3-Ph Variable Frequency	Output Current 100% Continuous	Overload Current 120% for 60 Secs.
4055B	5.5	5.0/3.7	380 – 480 VAC (±10%)	Input Voltage Level (Max.)	7.6 A	9.1 A
4080B	8.0	7.5/5.6			11.0 A	13.2 A
4110B	11.0	10.0/7.5			14.0 A	16.8 A
4160B	16.0	15.0/11.2			21.0 A	25.2 A
4220B	22.0	20.0/14.9			27.0 A	32.4 A
4270B	27.0	25.0/18.6			34.0 A	40.8 A
4330B	33.0	30.0/22.4			42.0 A	50.4 A
4400B	40.0	40.0/30.0			52.0 A	62.4 A
4500B	50.0	50.0/37.0			65.0 A	78.0 A
4600B	60.0	60.0/45.0			77.0 A	92.4 A
4750B	75.0	75.0/55.0			96.0 A	115.2 A
410KB	100	100/75.0			124.0 A	148.8 A
412KB	125	125/90.0			156.0 A	187.2 A
415KB	150	150/110			190.0 A	228.0 A
420KB	200	200/150			240.0 A	288.0 A
425KB	250	250/185			302.0 A	362.4 A
430KB	300	300/220			370.0 A	444.0 A
435KB	350	350/280			450.0 A	540.0 A
440KB	400	400/296			480.0 A	576.0 A

Table 17. 600 Volt NEMA Type-1 Chassis standard ratings table.

Model VT130H7U	Rated KVA	Motor HP/Kw	Input Voltage 3-Ph 50/60 ± 2 Hz	Output Voltage 3-Ph Variable Frequency	Output Current 100% Continuous	Overload Current 120% for 60 Secs.
6035B	3.5	3.0/2.2	495 – 600 VAC (+5/-10%)	Input Voltage Level (Max.)	4.0 A	4.8 A
6060B	6.0	5.0/3.7			6.1 A	7.3 A
6080B	8.0	7.5/5.6			9.0 A	10.8 A
6120B	12.0	10.0/7.5			12.0 A	14.4 A
6160B	16.0	15.0/11.2			17.0 A	20.4 A
6220B	22.0	20.0/14.9	495 – 600 VAC (±10%)		22.0 A	26.4 A
6270B	27.0	25.0/18.6			27.0 A	32.4 A
6330B	33.0	30.0/22.4			32.0 A	38.4 A
6400B	40.0	40.0/30.0			41.0 A	49.2 A
6500B	50.0	50.0/37.0			52.0 A	62.4 A
6600B	60.0	60.0/45.0			62.0 A	74.4 A
6750B	75.0	75.0/55.0			77.0 A	92.4 A
610KB	100	100/75.0			99.0 A	118.8 A
612KB	125	125/90.0			125.0 A	150.0 A
615KB	150	150/110			150.0 A	180.0 A
620KB	200	200/150			200.0 A	240.0 A
625KB	250	250/185			250.0 A	300.0 A
630KB	300	300/220			300.0 A	360.0 A
635KB	350	350/259			336.0 A	403.2 A

Cable/Terminal Specifications

Installation should conform to the 2002 National Electrical Code Article 110 (NEC) (Requirements for Electrical Installations), all regulations of the Occupational Safety and Health Administration, and any other applicable national, regional, or industry codes and standards.

Note: *The following ratings are guidelines and shall not be the sole determining factor of the lug or wire size used with the ASD. Application-specific applicables, wire insulation type, conductor material, and local and regional regulations are but a few of the considerations when selecting the actual lug and wire type to be used with the ASD.*

For further installation information see the section titled [Installation and Connections on pg. 18](#).

Table 18. 230-volt H7 ASD Cable/Terminal Specifications.

Model VT130H7U	MCP	Typical Wire/Cable Size (AWG or kcmil)			AM, FM, and II Terminals	Control Terminals	Lug Size Range Wire-Size/Lug-Capacity for Input/Output Power	
		Input/Output Power		20 (3-core shield)				18 (2-core shield)
		Recommended	Maximum					
2035B	20	14	10	20 (3-core shield)	18 (2-core shield)	24 to 8		
2055B	30	12	10					
2080B	50	10	10					
2110B	50	8	4			18 to 4		
2160B	75	6	4					
2220B	100	4	4					
2270B	125	3	2					
2330B	150	2	2					
2400B	175	1/0	1/0				16 to 1	
2500B	200	2/0	2/0			10 to 1/0		
2600B	250	3/0	4/0			12 to 4/0		
2750B	300	*1/0	4/0			*(6 to 250)		
210KB	400	*3/0	4/0					
212KB	500	*250	500					
215KB	600	*350	500	*(1/0 to 500)				

Note: *Input and Output power wires require shielding for CE compliance.*

Note: *(*) Indicates that the item is one of a set of two parallel cables.*

Table 19. 460-volt H7 ASD Cable/Terminal Specifications.

Model VT130H7U	MCP	Typical Wire/Cable Size (AWG or kcmil)			Lug Size Range		
		Input/Output Power		AM, FM, and II Terminals	Control Terminals	Wire-Size/Lug-Capacity for Input/Output Power	
		Recommended	Maximum				
4055B	15	14	10	20 (3-core shield)	18 (2-core shield)	24 to 8	
4080B	15	14	10				
4110B	30	12	10				
4160B	30	10	4			18 to 4	
4220B	50	8	4				
4270B	75	8	4				
4330B	75	6	4				
4400B	100	6	4				
4500B	100	4	4				
4600B	125	3	2				16 to 1
4750B	175	1	**2				10 to 1/0
410KB	200	2/0	2/0				12 to 4/0
412KB	250	3/0	4/0				*(6 to 250)
415KB	300	*1/0	*4/0				
420KB	350	*3/0	*4/0			*(1/0 to 500)	
425KB	400	*250	*500				
430KB	600	*350	*500				
435KB	700	*500	*500				
440KB	700	*500	*500				

Note: Input and Output power wires require shielding for CE compliance.

Note: (*) Indicates that the item is one of a set of two parallel cables.

Note: (**) Indicates that a 1.5” conduit orifice is required if using the recommended cable size.

Table 20. 600-volt H7 ASD Cable/Terminal Specifications.

Model VT130H7U	MCP	Typical Wire/Cable Size (AWG or kcmil)			Lug Size Range		
		Input/Output Power		AM, FM, and II Terminals	Control Terminals	Wire-Size/Lug-Capacity for Input/Output Power	
		Recommended	Maximum				
6035B	15	14	10	20 (3-core shield)	18 (2-core shield)	24 to 8	
6060B	15	14	10				
6080B	15	14	10				
6120B	30	14	10				
6160B	30	10	10				
6220B	50	10	4			18 to 4	
6270B	50	8	4				
6330B	50	8	4				
6400B	75	6	4				
6500B	100	6	4				
6600B	100	4	2				
6750B	125	3	2				
610KB	175	1	**2				16 to 1
612KB	200	2/0	*4/0				
615KB	225	3/0	*4/0				
620KB	300	*2/0	*500				
625KB	400	*3/0	*500				
630KB	400	*250	*500			*(1/0 to 500)	
635KB	500	*300	*500				

Note: Input and Output power wire requires shielding for CE compliance.

Note: (*) Indicates that the item is one of a set of two parallel cables.

Note: (**) Indicates that a 1.5” conduit orifice is required if using the recommended cable size.

Link Reactor Information

Selection of a link reactor (DCL) is often application specific. This document will provide guidelines for selecting link reactors for the H7 ASD series of ASDs.

The 410K and the 600-Volt series of ASDs above 60 HP allow for the reactor to be mounted within the enclosure of the ASD. All other H7 ASDs require that the DCL be mounted externally.

When selecting and mounting an external DCL, the air flow around the reactor, the thermal capability of the reactor, the allowable voltage loss, and the amount of harmonic reduction required will be considerations.

Table 21. DCL Selection Table.

Model Number VT130H7U	DCL Part Number	DCL Inductance (mH)	DCL (Amps)	Model Number VT130H7U	DCL Part Number	DCL Inductance (mH)	DCL (Amps)
2035B	Contact Toshiba for DCL selection assistance.			412KB	Contact Toshiba for DCL selection assistance.		
2055B			415KB				
2080B	36350	0.40	30.0	420KB			
2110B	36351	0.30	38.0	425KB			
2160B	36376	0.20	57.0	430KB			
2220B	36353	0.20	76.0	435KB			
2270B	36355	0.10	114	440KB			
2330B	Contact Toshiba for DCL selection assistance.			6035B			
2400B				6060B	36356	2.50	11.0
2500B				6080B	36356	2.50	11.0
2600B				6120B	36359	0.90	29.0
2750B				6160B	36359	0.90	29.0
210KB				6220B	36360	0.70	39.0
212KB				6270B	36362	0.50	55.0
215KB				6330B	36361	0.50	50.0
4055B				6400B	36363	0.40	75.0
4080B				6500B	36363	0.40	75.0
4110B	36358	1.30	20.0	6600B	36364	0.30	88.0
4160B	36359	0.90	29.0	6750B	36365	0.20	114.0
4220B	36360	0.70	39.0	610KB	36366	0.20	141.0
4270B	36361	0.50	50.0	612KB	36367	0.15	175.0
4330B	36363	0.40	75.0	615KB	41443	0.19	260.0
4400B	36364	0.30	88.0	620KB	41443	0.19	260.0
4500B	36365	0.20	114.0	625KB	45259	0.10	360.0
4600B	36365	0.20	114.0	630KB	Contact Toshiba for DCL selection assistance.		
4750B	36366	0.20	141.0	635KB			
410KB	42769	0.14	205.0				

H7 ASD Optional Devices

The ASD may be equipped with several options which are used to expand the functionality of the ASD. [Table 22](#) lists the available options and their functions.

Table 22. H7 ASD Optional devices and functions.

Item	Device Function
ASD7-SIM2	Emulates the input control signals of the H7 ASD via switches and pots.
ASD-BPC	Provides dust protection for the H7 ASD when the EOI is removed or mounted remotely.
ASD-CAB-PC	Female 9-pin d-type to RJ-45 (PC to ASD cable).
ASD-EOI-N4	A replacement NEMA-4 EOI (without Rotary Encoder)
ASD-ISO-1	Provides isolation of the Control Board output circuit from the AM/FM output and from the II input.
ASD-MTG-KIT	EOI Remote Mounting Kit. See the section titled EOI Remote Mounting on pg. 202 for further information on this option.
ASD-RTC	The Real Time Clock provides the user with a time stamp of the Start , Run , and Fault events.
ASD-SS	This option board is used to provide a hardware-based speed search function. <i>Note: The ASD-SS is a factory-authorized service center-installed option for all 1 – 5 HP ASDs, 10 – 25 HP 230 volt ASDs, and 15 – 40 HP 460 volt ASDs (see F314).</i>
ASD-TB1-AC1	Provides 120 VAC discrete terminal activation and additional I/O terminals.
Conduit Extender Box (option)	Provides more working space for conduit installation than the standard conduit plate.
HS35 Encoder	Provides rotational speed and/or directional information. The Encoder is mounted on the motor shaft or the shaft-driven equipment.
ASD – Multicom Option Board	
<i>Note: Multicom boards are identified as ASD-Multicom-A, -B, -F, etc.</i>	
-A	Incorporates the Modbus , Profibus , or Device Net communications protocol for system control and is able to receive and process Vector Control feedback.
-B	Provides a line driver and open collector interface for system control.
-F	The Tosline-F10 interface provides high-speed communication to Toshiba control equipment via twisted pair wiring.
-J	Able to receive and process vector control feedback via line driver or open collector interface.
-S	The Tosline-S20 interface provides high-speed communication to Toshiba control equipment via fiber optics.
-X	Provides extended terminal I/O functions for monitoring, feedback, and control.
<i>Note: See the user manual of the applicable option for further information on each item.</i>	

H7 ASD Spare Parts Listing

Table 23. 230 Volt 3.0 – 40 HP Spare Parts Listing.

MODEL NUMBER	DC BUS FUSE	CONTACTOR	FAN		RESISTOR	TRANSISTORS	RECT.	MAIN CAPS	MOV	LCD DISPLAY	
			FAN1	FAN2							
VT130H7U	FU2	MS1			R21(A)	IGM	RECT.	CAP	MOV	EOI	
2035B	00646	49648A	50037	N/A	N/A	Reside on the main circuit PCB.				49012	
2055B	00647										
2080B	50248			51088							
2110B	00638	45678	46023	N/A	00388	55624	45056	45593 (2)	49054		
2160B	00640					55625	45009	30536 (2)			
2220B	00641				45813	00388 (2)		47963			47342
2270B							47964 (3)	52095			
2330B											44362
2400B	00642				42338						

Parenthesized are the total quantities per model number. Toshiba recommends a spare parts inventory of 2 minimum for the parts listed. If the total quantity per unit is 3 or more then the suggested spare parts inventory is one third of the total unit quantity (2 minimum).

Table 24. 230 Volt 3.0 – 40 HP PCB Spare Parts Listing.

MODEL NUMBER	PCB Part Numbers							
	48048	56223	48605	56220	56000	51389		
VT130H7U	A, B, C, etc. PCB Typeform							
2035B	A			D	B			
2055B				E	B			
2080B				B				
2110B				A	A		B	
2160B				A	B		B	
2220B				B	C		B	
2270B				B	C		C	
2330B				B	D		C	
2400B							C	A

The following items are common to the above-listed typeforms.

Control Terminal Strip PCB — 48570A.

4-20 mA PCB — 50611A.

Toshiba recommends a spare parts inventory of 2 minimum for the parts listed.

Table 25. 460 Volt 5.0 – 400 HP Spare Parts Listing.

MODEL NUMBER	INPUT FUSE	CONTROL FUSE	DC BUS FUSE	CONTACTOR		FAN		RESISTOR	XSISTORS	RECT.	MAIN CAPS	MOV		LCD DISPLAY	
				MS1	MS2	FAN1	FAN2/3					R21 (A) (B) (C)	IGM		RECT.
VT130H7U	R, S, and T	FU1 (A)	FU2(A)	MS1	MS2	FAN1	FAN2/3	R21 (A) (B) (C)	IGM	RECT.	CAP	MOV1	MOV (2)(3)	EOI	
4055B	N/A	N/A	00621	49648C	N/A	50037	N/A	N/A	Reside on the Main Circuit PCB.						49012
4080B			50830	49648D			51088								
4110B			02424	45678			46023		00388	47965	45237	30560 (2)			
4160B			00629			46023		00388		47966	45238	34835 (27)			
4220B				03250			N/A		00388 (2)			47967	45239	48019 (2)	
4270B			37160 (2)			42338		44362		35489	47968 (3)			46465	
4330B				42337			42338		44362			35489	47969 (3)		
4400B			42338			42767		44362		35489	47969 (3)			45241 (3)	
4500B				42768			48718		32028			30634 (2)	50000 (3)		
4600B			51973			54140		00226		35489 (2)	50000 (6)			45241 (12)	
4750B				39660 (2)			37578 (2)		51958			37698	55383		
410KB			42768			48718		32028		30634 (2)	50000 (3)			45242 (6)	
412KB				30965			54140		00226			35489 (2)	50000 (6)		
415KB			03672 (2)			55383		00224/00226		37580	37565 (18)			PC40300 P042 (3)	
420KB				52754			37693		00226			37580	37565 (18)		
425KB			3670			37693		00226		37580	37565 (18)			PC40300 P042 (3)	
430KB															
435KB															
440KB															

Parentthesized are the total quantities per model number. Toshiba recommends a spare parts inventory of 2 minimum for the parts listed. If the total quantity per unit is 3 or more then the suggested spare parts inventory is one third of the total unit quantity (2 minimum).

Table 26. 460 Volt 5.0 – 400 HP PCB Spare Parts Listing.

MODEL NUMBER	PCB Part Numbers													
	38383	44292	44293	48605	48776	50001	51389	52266 (Assy)	53300	56000	56220	56221	56222	56223
VT130H7U	A, B, C, etc. PCB Typeform													
4055B											D	K		
4080B											D		B	
4110B											D		C	
4160B				E							D			C
4220B				E							E			C
4270B				F							E			D
4330B				G							E			D
4400B				H							E			D
4500B				J							E			D
4600B					B		A (3)	(Assy)			E		G	
4750B					B			(Assy)			E		C	
410KB					B			(Assy)			E		C	
412KB					B			(Assy)			E		E	
415KB					B			(Assy)	A (3)		E		E	
420KB					B			(Assy)	A (3)		E		F	
425KB					B			(Assy)	B (3)		E		G	
430KB					B			(Assy)	B (3)		E		G	
435KB					B			(Assy)	B (3)		E		G	
440KB	A (6)	A (3)	A (3)		B	H					E		G	
<p>The following PCBs are common to the above-listed typeforms.</p> <p>Control Terminal Strip PCB — 48570A.</p> <p>4-20 mA PCB — 50611A.</p> <p>Parenthesized are the total quantities per unit. Toshiba recommends a spare parts inventory of 2 minimum for the parts listed. If the total quantity per unit is 3 or more then the suggested spare parts inventory is one third of the total unit quantity (2 minimum).</p>														

Table 27. 600 Volt 3.0 – 300 HP Spare Parts Listing.

MODEL NUMBER	INPUT FUSE	CONTROL FUSE	DC BUS FUSE	CONTACTOR		FAN		RESISTOR	XSISTORS	RECT.	MAIN CAPS	MOV		LCD DISPLAY				
				MS1	MS2	FAN1	FAN2					R21 (A) (B) (C)	IGM		RECT.	CAP	MOV1	MOV (2)(3)
VT130H7U	R, S, and T	FU1 (A)	FU2 (A)															
6035B	N/A	N/A	49110	49648F	N/A	50037	N/A	N/A	Reside on the Main Circuit PCB.									
6060B																		
6080B																		
6120B																		
6160B			49660	49648G		51264	00388											
6220B			56353	32143		N/A	46023	N/A	00388 (2)	55626	45237	47973 (2)	49055	33030 (2)				
6270B												48023 (2)						
6330B											49114 (6)							
6400B											49115 (6)							
6500B			56351	32143 (2)														
6600B			45479	42337		N/A	56191	N/A	35489	44362	46465	47968 (3)	47974 (6)					
6750B												47969 (3)		48023 (6)				
610KB																		
612KB										100620 (3)	37164 (2)	45520	42768 (2)	N/A	32028	30634	49999 (3)	45242 (6)
615KB		48020 (9)																
620KB	39714 (3)	50518 (2)	51973	N/A	54140	00226	35489 (2)	49999 (6)	45241 (6)	45182 (9)	32911							
625KB																		
630KB	39659 (3)	51958	N/A	37698	54140	00224	35489 (2)	49999 (6)	45242 (6)	50855 (9)	32910 (2)							
635KB									37578 (3)	37578 (2)							37568 (9)	
Parenthesized are the total quantities per model number. Toshiba recommends a spare parts inventory of 2 minimum for the parts listed. If the total quantity per unit is 3 or more then the suggested spare parts inventory is one third of the total unit quantity (2 minimum).																		

Table 28. 600 Volt 3.0 – 300 HP PCB Spare Parts Listing.

MODEL NUMBER	PCB Part Numbers											
	42180	48776	51580	52266	53300	53388	53390	55455	56000	56220	56221	56222
VT130H7U	A, B, C, etc. PCB Typeform											
6035B										B	N	
6060B										B	P	
6080B										B		D
6120B										B		E
6160B										B		F
6220B	Q	C						A	B			J
6270B	Q	C						A	C			J
6330B	R	C						A	C			J
6400B	U	C						A	C			J
6500B	V	C						A	C			J
6600B		C		52266					C			M
6750B		C		52266			A (3)		C			K
610KB		C		52266			A (3)		C			K
612KB		A	B	52266	A (3)	A (3)			C			K
615KB		A	B	52266	A (3)	A (3)			C			K
620KB		A	B	52266	B (3)	A (6)			C			L
625KB		A	B	52266	B (3)	A (6)			C			L
630KB		A	B	52266	B (3)	A (6)			C			L
635KB		A	B	52266	B (3)	A (6)			C			L
<p>The following PCBs are common to the above-listed typeforms.</p> <p>Control Terminal Strip PCB — 48570A.</p> <p>4-20 mA PCB — 50611A.</p> <p>Toshiba recommends a spare parts inventory of 2 minimum for the parts listed.</p>												

Index

Numerics

0 Hz Command Function, 112
 0 Hz Dead Band Signal, 110
 12-pulse operation, 22

A

Abnormal Speed Detection Filter Time, 165
 Abnormal Speed Settings, 53
 Acc/Dec Base Frequency Adjustment, 168
 Acc/Dec Group, 149
 Acc/Dec Switching Frequency #1, 149
 Accel #1 Time, 64
 Accel #2 Time, 147
 Accel #3 Time, 150
 Accel #4 Time, 151
 Accel/Decel #1 – #4 Settings, 58
 Accel/Decel #1 Settings, 48
 Accel/Decel Lower Limit Time, 150
 Accel/Decel Pattern #1, 148
 Accel/Decel Pattern #2, 149
 Accel/Decel Pattern #3, 150
 Accel/Decel Pattern #4, 151
 Accel/Decel Settings, 58
 Accel/Decel Special, 58
 Accel/Decel Special Display Resolution, 172
 Accel/Decel Switching Frequency #2, 151
 Accel/Decel Switching Frequency #3, 152
 Acceleration, 64
 Acceleration Time Adjustment, 168
 Adjust Accel/Decel Automatically, 37
 Alarm Popups, 48
 Alarms, 182
 AM, 23, 25, 57
 AM Terminal Adjustment, 170
 AM Terminal Assignment, 170
 AM, FM, FP, and Analog 1&2 settings, 62
 Analog, 171
 Analog 1 Terminal Adjustment, 171
 Analog 1 Terminal Setting, 170
 Analog 2 Terminal Adjustment, 171
 Analog 2 Terminal Setting, 171
 Analog Filter, 51
 Analog Input Filter, 96
 Analog Input Functions, 50
 Analog1, 57
 Analog2, 57
 ASD – Multicom Option Boards, 212
 ASD Control, 27
 ASD Number, 176
 ASD Overload, 184
 ASD7-SIM2, 212
 ASD-BPC, 212
 ASD-CAB-PC, 212
 ASD-EOI-N4, 212
 ASD-FUSEKIT-12P, 22
 ASD-ISO-1, 212
 ASD-MTG-KIT, 212
 ASD-NANOCOM, 27
 ASD-side Switching Wait Time, 127
 ASD-SS, 212
 ASD-TB1-AC1, 212
 At-Frequency Powerline Switching, 126
 Atn, 184
 At-trip Recorded Parameters, 188
 Automatic Accel/Decel #1, 60
 Autotune Error, 184
 Autotuning, 14

B

Backlash Setup, 58
 Base Frequency Volts, 53
 Bezel Mounting Dimensions, 204
 Bezel Mounting Hardware, 202
 Bias and Gain, 93, 97, 100, 103
 BIN Input Control Setup, 106
 BIN Speed Control Setup, 106
 BIN Speed Frequency #1, 107
 BIN Speed Frequency #2, 107
 BIN Speed Reference #1, 106
 BIN Speed Reference #2, 107
 BIN Torque Control Setup, 106
 BIN Torque Reference Setpoint #1, 107
 BIN Torque Reference Setpoint #2, 108
 Brake Fault Internal Timer, 167
 Brake Fault Timer, 53
 Break/Make Start, 117

C

Cable/Terminal Specifications, 208
 Carrier Frequency, 58, 117
 CC, 23, 25
 CE compliance, 190
 CE Compliance Requirements, 11
 Changed from Default, 48
 Changed From Default screen, 35

- Circuit breaker configuration, 19
 - Clearing a Trip, 189
 - CM1, 182
 - CM2, 182
 - CN3 Pinout, 28
 - CN7 Pinout, 29
 - CNU1/1A and CNU2/2A Pinout, 28
 - CNU2/2A Pinout, 28
 - Command Control Selections, 42
 - Command Mode Selection, 60
 - Command Source, 38
 - Commercial Power Switching Frequency
 - Hold Time, 127
 - Commercial Power Wait Time, 127
 - Common Serial (TTL), 27
 - Communication Baud Rate (logic), 175
 - Communication Error, 56, 180, 184
 - Communication Internal, 176
 - Communication Reference Adjust, 56
 - Communication Setting Parameters, 55
 - Communication Settings, 55
 - Communications Speed Frequency #1, 178
 - Communications Speed Frequency #2, 179
 - Communications Speed Reference #1, 178
 - Communications Speed Reference #2, 178
 - Compensation Coefficient for Iron Loss, 146
 - concerns about this publication, 3
 - Conduit Extender Box, 197
 - Conduit Plate Information, 190, 195
 - Configuration and Menu Options, 44
 - Connecting the ASD, 20
 - Connection Diagram, 31
 - Constant Vector Control, 145
 - Continued Stall Until Trip During Power Operation, 142
 - continuous splash screen, 28
 - Contrast (adjustment), 48
 - Control, 27
 - Control Board, 27
 - Control Power Undervoltage, 184
 - Control Terminal Strip, 23
 - CPU Fault, 185
 - Crane/Hoist Load, 58
 - Cumulative Run Timer, 53
 - Cumulative Run Timer Alarm Setting, 165
 - Current Control Integral Gain, 130
 - Current Control Proportional Gain, 130
 - Current Differential Gain, 142
 - Current Vector Control, 145
 - Current/Voltage Specifications, 205
 - Custom V/f Five-Point Setting #1 Frequency, 90
 - Custom V/f Five-Point Setting #1 Voltage, 90
 - Custom V/f Five-Point Setting #2 Frequency, 90
 - Custom V/f Five-Point Setting #2 Voltage, 90
 - Custom V/f Five-Point Setting #3 Frequency, 91
 - Custom V/f Five-Point Setting #3 Voltage, 91
 - Custom V/f Five-Point Setting #4 Frequency, 91
 - Custom V/f Five-Point Setting #4 Voltage, 91
 - Custom V/f Five-Point Setting #5 Frequency, 91
 - Custom V/f Five-Point Setting #5 Voltage, 91
- ## D
- Date and time setting, 48
 - dbOn, 184
 - DC Braking, 52
 - DC Bus Undervoltage, 185
 - DC Fuse Open, 185
 - DC Injection Braking Current, 111
 - DC Injection Braking Start Frequency, 111
 - DC Injection Braking Time, 111
 - DCL Selection Table, 211
 - Dead Time Compensation, 59
 - Dead Time Compensation (Enable), 146
 - Dead-time Compensation Bias, 146
 - Decel #1 Time, 64
 - Decel #2 Time, 147
 - Decel #3 Time, 150
 - Decel #4 Time, 151
 - Deceleration Time Adjustment, 169
 - Default Setting Changes, 35
 - Default Term. Setting, 23
 - Derate Threshold frequency, 117
 - Direct Access, 48
 - Direct Access Parameter Information, 60
 - Direct Access Parameters/Numbers, 60
 - Direction (of motor rotation), 63
 - Discrete Input, 23
 - Discrete Input Terminal Assignment, 77
 - Discrete Output, 23
 - Display Units, 49
 - Display Units for Voltage and Current, 171
 - Disposal, 4
 - Down Key, 32
 - Drive Characteristics, 17
 - Driving Torque Limit #1, 140
 - Driving Torque Limit #2, 140
 - Driving Torque Limit #3, 141
 - Driving Torque Limit #4, 141
 - Drooping, 122
 - Drooping Control, 55
 - Drooping Gain, 122
 - Drooping Insensitive Torque Range, 122
 - Drooping Output Filter, 122
 - Drooping Reference, 123
 - Dynamic Braking, 52, 119
 - Dynamic Braking Enable, 119
 - Dynamic Braking Resistor Overcurrent, 185
 - Dynamic Braking Resistor Overload, 185

E

Earth Fault, 185
 Earth Fault Alarm Level, 167
 Earth Fault Alarm Time, 167
 Earth Fault Trip Level, 168
 Earth Fault Trip Time, 168
 EEPROM Data Fault, 185
 EEPROM Fault, 185
 Electronic Gear Setting, 129
 Electronic Operator Interface, 32
 Electronic Thermal Protection #1, 161
 Electronic Thermal Protection #2, 87
 Electronic Thermal Protection #3, 88
 Electronic Thermal Protection #4, 89
 Emergency Off, 185
 Emergency Off DC Injection Application Time, 162
 Emergency Off Mode Settings, 162
 Emergency Off Setting, 52
 EMG, 182
 Enclosure Dimensions, 190
 Enclosure Dimensions/Weight, 190
 Encoder, 212
 Encoder Action, 48
 Encoder Loss, 185
 End Frequency, 110
 Enter Key, 32
 EOI Bezel Mounting Dimensions, 204
 EOI Bezel Plate Dimensions (mounting), 204
 EOI Features, 32
 EOI Installation Precautions, 202
 EOI Operation, 33
 EOI Remote Mounting, 202
 EOI Remote Mounting using the ASD-MTG-KIT, 203
 EOI Remote Mounting w/o the ASD-MTG-KIT, 203
 EOI Setup Options, 48
 Equipment Inspection, 3
 Escape Key, 32
 Excitation Starting Rate, 146
 Exciting Strengthening Coefficient, 145
 Extended Terminal Function, 71
 Extender Cables, 202

F

F, 23, 24
 F Input Terminal Assignment, 72
 F Input Terminal Delay, 81
 Fan Control, 53, 165
 Fault, 181
 Fault Status, 47
 Faults, 181
 Feedback in Panel Mode, 173

Feedback Parameters, 54, 55
 Feedback Settings, 54
 Feedback Settings Differential (D) Gain, 129
 Feedback Source, 128
 Feedback Source Delay Filter, 128
 Ferraz Shawmut Semiconductor fuse, 22
 FH, 64
 Filter Selection Table, 13
 FL Off Delay, 85
 FL On Delay, 84
 FL Output Terminal Assignment, 80
 FLA, 23, 25
 FLA, B, and C switching relationship, 25
 Flash Memory Fault, 185
 FLB, 23, 25
 FLC, 23, 25
 FM, 23, 25, 57
 FM Terminal Adjustment, 61
 FM Terminal Assignment, 61
 Forward Speed Limit Input, 138
 Forward Speed Limit Level, 138
 FP, 23, 25
 FP Terminal Adjustment, 171
 FP Terminal Setting, 171
 FP Terminal Settings, 50
 Frequency Command screen, 34
 Frequency Control, 58
 Frequency Control Selections, 43
 Frequency Display Resolution, 172
 Frequency for Automatic High-Speed Operation
 at Light-Load, 126
 Frequency Limit at Position, 130
 Frequency Mode #1, 61
 Frequency Mode #2, 48, 95
 Frequency Override Additive Input, 169
 Frequency Override Multiplying Input, 170
 Frequency Point Selection, 177
 Frequency Reference Source, 38
 Frequency Set Mode, 44
 Frequency Setting, 48
 Frequency Setting Parameters, 51
 Fundamental Parameters, 48
 Fwd/Rev Disable, 52

G

Gate Array Fault, 185
 General Safety Information, 1
 Group #1 Speed #1, 153
 Group #1 Speed #2, 153
 Group #1 Speed #3, 153
 Group #1 Speed #4, 153
 Group #1 Speed #5, 153

Group #1 Speed #6, 154
 Group #1 Speed #7, 154
 Group #1 Speed #8, 154
 Group #1 Speed Repeat Factor, 153
 Group #2 Speed #1, 154
 Group #2 Speed #2, 154
 Group #2 Speed #3, 154
 Group #2 Speed #4, 154
 Group #2 Speed #5, 154
 Group #2 Speed #6, 154
 Group #2 Speed #7, 155
 Group #2 Speed #8, 155
 Group #2 Speed Repeat Factor, 154
 Group #3 Speed #1, 155
 Group #3 Speed #2, 155
 Group #3 Speed #3, 155
 Group #3 Speed #4, 155
 Group #3 Speed #5, 155
 Group #3 Speed #6, 155
 Group #3 Speed #7, 155
 Group #3 Speed #8, 156
 Group #3 Speed Repeat Factor, 155
 Group #4 Speed #1, 156
 Group #4 Speed #2, 156
 Group #4 Speed #3, 156
 Group #4 Speed #4, 156
 Group #4 Speed #5, 156
 Group #4 Speed #6, 156
 Group #4 Speed #7, 156
 Group #4 Speed #8, 156
 Group #4 Speed Repeat Factor, 156

H

H7 Adapter Mounting Plates, 198
 H7 ASD Control, 27
 H7 Part Numbering Convention, 190
 Handling and Storage, 4
 Heavy-Load Torque During Forward Acceleration, 125
 Heavy-Load Torque During Forward Deceleration, 125
 Heavy-Load Torque During Reverse Acceleration, 125
 Heavy-Load Torque During Reverse Deceleration, 126
 Hz Per User-defined Unit, 172

I

I/O and Control, 23
 I/O Circuit Configurations, 30
 ICCDESIGNS, 27
 II, 23, 25
 Important Notice, 2
 Initial Setup, 34

Input Phase Loss, 185
 Input Special Functions, 50
 Input Terminal 12 Assignment, 75
 Input Terminal 13 Assignment, 75
 Input Terminal 14 Assignment, 76
 Input Terminal 15 Assignment, 76
 Input Terminal 16 Assignment, 76
 Input Terminal Assignment, 50
 Input Terminal Delays, 51
 Input Terminal Priority, 71
 Inrush Current Suppression, 163
 Installation and Connections, 18
 Installation Notes, 18
 Installation Precautions, 5
 Integral (I) Gain, 128
 Interlock with ST, 163
 Introduction, 2

J

Jog Run Frequency, 113
 Jog Settings, 51
 Jog Setup Using the Control Terminal Strip, 113
 Jog Setup Using the EOI, 113
 Jog Stop Control, 114
 Jump Frequencies, 58
 Jump Frequency #1, 114
 Jump Frequency #1 Bandwidth, 114
 Jump Frequency #2, 114
 Jump Frequency #2 Bandwidth, 114
 Jump Frequency #3, 115
 Jump Frequency #3 Bandwidth, 115
 Jump Frequency Processing, 115

L

L1/R, 21
 L2/S, 21
 L3/T, 21
 LCD Display, 32
 LCD Port Connection, 56
 Lead Length Specifications, 22
 LED Option Override Multiplication Gain, 173
 Light Load Conditions, 15
 Light-Load High-Speed Operation Heavy-Load
 Detection Time, 124
 Light-Load High-Speed Operation Load
 Detection Time, 124
 Light-Load High-Speed Operation Load Wait Time, 124
 Light-load High-speed Operation Selection, 123
 Light-Load High-Speed Operation Switching
 Lower-Limit Frequency, 124

Line Power Switching, 50, 51
 Link Reactor Information, 211
 Load Drooping, 185
 Load End Short Circuit, 185
 Load Inertia (Acc/Dec Torque), 123
 Load Sharing Gain Input, 137
 Load Torque Filter (Acc/Dec Torque), 123
 Load-produced Negative Torque, 16
 Local Remote Key, 48
 Local|Remote Key, 32
 Lockout, 49
 LOD Boost Time, 174
 LOD Control and Stopping Method, 174
 LOD Feedback Level (Hz), 175
 LOD Restart Delay Time, 175
 LOD Setpoint Boost (Hz), 174
 LOD Start Level (Hz), 174
 LOD Start Time, 174
 Low Current, 185
 Low Current Settings, 53
 Low Current Trip, 163
 Low Current Trip Threshold, 163
 Low Current Trip Threshold Time, 163
 Low Output Disable, 174
 Low Speed Operation, 14
 Low Speed Signal Output Frequency, 68
 Lower Deviation Limits, 129
 Lower Limit Frequency, 36, 65

M

Main Board EEPROM Fault, 185
 Manual Torque Limit Settings, 54
 Manual's Purpose and Scope, 3
 maximum Carrier Frequency, 117
 Maximum Frequency, 64
 Meter Terminal Adjustment Parameters, 57
 Mode #1/#2 Switching Frequency, 95
 MOFF, 182
 MON/PRG, 33
 Monitor Mode, 46
 Monitor Setup, 57
 MOP acceleration rate, 78
 MOP deceleration rate, 78
 Motor #1 Base Frequency, 65
 Motor #1 Max Output Voltage, 119
 Motor #1 Torque Boost, 66
 Motor #2 Base Frequency, 86
 Motor #2 Max Output Voltage, 87
 Motor #2 Torque Boost, 87
 Motor #3 Base Frequency, 87
 Motor #3 Max Output Voltage, 88
 Motor #3 Torque Boost, 88

Motor #4 Base Frequency, 88
 Motor #4 Max Output Voltage, 89
 Motor #4 Torque Boost, 89
 Motor 150% OL Time Limit, 163
 Motor Braking, 16
 Motor Capacity, 135
 Motor Characteristics, 14
 Motor connection diagram, 21
 Motor Constant 1 (primary resistance), 134
 Motor Constant 2 (secondary resistance), 135
 Motor Constant 3 (exciting inductance), 135
 Motor Constant 3 Enable, 136
 Motor Constant 4 (load inertia), 135
 Motor Constant 5 (leakage inductance), 135
 Motor Counter Data, 131
 Motor Current Rating, 37
 Motor Overload, 185
 Motor Overload Trip, 53
 Motor Parameters, 57
 Motor Set #1, 48, 57
 Motor Set #2, 57
 Motor Set #3, 57
 Motor Set #4, 57
 Motor Settings, 57
 Motor Shaft Fixing Control, 111
 Motor Shaft Stationary Control, 112
 Motor Type, 136
 Motor/Load Combinations, 15
 Motorized Pot Frequency at Power Down, 72
 Motorized Pot Settings, 52
 Mounting the ASD, 19
 MS1 AUX, 18

N

Number of PG Input Pulses, 129
 Number of Poles of Motor, 135
 Number of Retries, 118

O

OC, 182
 OH, 182
 OJ, 182
 OL Reduction Starting Frequency, 162
 OLI, 183
 OLM, 183
 OLR, 183
 ON Input Terminal Assignment, 72
 On-Trip Powerline Switching, 126
 OP, 183
 Operation (Local), 34

Operation Above 60 Hz, 15
 Operational and Maintenance Precautions, 10
 Option Fault, 186
 Option Type, 47
 Optional Devices, 212
 OT, 183
 OUT1, 23, 25
 OUT1 Off Delay, 85
 OUT1 On Delay, 84
 Out1 Out2 FL, 46
 OUT1 Output Terminal Assignment, 80
 OUT2, 23, 25
 OUT2 Off Delay, 85
 OUT2 On Delay, 84
 OUT2 Output Terminal Assignment, 80
 OUT4 Off Delay, 86
 OUT4 On Delay, 84
 OUT5 Off Delay, 86
 OUT5 On Delay, 84
 OUT6 Off Delay, 86
 OUT6 On Delay, 85
 OUT7 Off Delay, 86
 OUT7 On Delay, 85
 Output #4 Terminal Assignment, 80
 Output #5 Terminal Assignment, 81
 Output #6 Terminal Assignment, 81
 Output #7 Terminal Assignment, 81
 Output Current Protection Fault, 186
 Output Phase Loss, 186
 Output Phase Loss Detection, 162
 Output Terminal Assignments, 82
 Output Terminal Delays, 51
 Output Terminal Functions, 50
 Output terminal selections, 62
 Over Exciting Cooperation, 145
 Over Speed, 186
 Overcurrent During Acceleration, 186
 Overcurrent During Deceleration, 186
 Overcurrent During Run, 186
 Overcurrent Protection, 17
 Overcurrent Stall Level, 161
 Overheat, 186
 Overload, 53
 Overload Protection, 14
 Override Control, 55
 Overspeed Detection Frequency Range, 165
 Overtorque, 187
 Overtorque Detection Time, 165
 Overtorque Settings, 53
 Overtorque Trip, 164
 Overtorque Trip/Alarm Level (Negative Torque), 164
 Overtorque Trip/Alarm Level (Positive Torque), 164
 Overvoltage During Acceleration, 187
 Overvoltage During Deceleration, 187

Overvoltage During Run, 187
 Over-voltage Stall, 119
 Overvoltage Stall Level, 166
 Overvoltage Stall Level (fast), 166

P

P24, 23, 25
 PA, 21, 119
 Panel Menu, 45
 Parity, 175
 Pattern #1 Characteristics (Pattern Run), 157
 Pattern #10 Characteristics (Pattern Run), 158
 Pattern #11 Characteristics (Pattern Run), 158
 Pattern #12 Characteristics (Pattern Run), 158
 Pattern #13 Characteristics (Pattern Run), 158
 Pattern #14 Characteristics (Pattern Run), 158
 Pattern #15 Characteristics (Pattern Run), 158
 Pattern #2 Characteristics (Pattern Run), 157
 Pattern #3 Characteristics (Pattern Run), 157
 Pattern #4 Characteristics (Pattern Run), 157
 Pattern #5 Characteristics (Pattern Run), 157
 Pattern #6 Characteristics (Pattern Run), 157
 Pattern #7 Characteristics (Pattern Run), 157
 Pattern #8 Characteristics (Pattern Run), 157
 Pattern #9 Characteristics (Pattern Run), 157
 Pattern Run, 55, 152
 Pattern Run #1 Run-Time Setting, 158
 Pattern Run #10 Run-Time Setting, 160
 Pattern Run #11 Run-Time Setting, 160
 Pattern Run #12 Run-Time Setting, 160
 Pattern Run #13 Run-Time Setting, 160
 Pattern Run #14 Run-Time Setting, 160
 Pattern Run #15 Run-Time Setting, 161
 Pattern Run #2 Continuation Mode Run-Time Setting, 158
 Pattern Run #3 Run-Time Setting, 159
 Pattern Run #4 Run-Time Setting, 159
 Pattern Run #5 Run-Time Setting, 159
 Pattern Run #6 Run-Time Setting, 159
 Pattern Run #7 Run-Time Setting, 159
 Pattern Run #8 Run-Time Setting, 159
 Pattern Run #9 Run-Time Setting, 160
 Pattern Run Control Parameters, 55
 Pattern Run Description, 152
 Pattern Run Setup, 152
 PB, 119
 PG Disconnect Detection, 129
 PG Input Phases, 129
 PG Input Speed Control Setup, 108
 PG Settings, 54
 PG Speed Frequency #1, 109
 PG Speed Frequency #2, 109

PG Speed Reference #1, 108
 PG Speed Reference #2, 109
 PG Type/Connection Error, 187
 Phantom Fault, 187
 Phase Loss, 53
 phase-shifting transformer, 22
 PID feedback, 128, 173
 PO, 21
 POFF, 183
 Position Completion Range, 130
 Position Deviation Error, 187
 Position Difference Limit (Droop Pulses Allowed), 167
 Position Loop Gain, 130
 Power Connections, 21
 Power Factor Correction, 15
 Power Running Torque Limit #1, 140
 PP, 23, 25
 Preferences, 48
 Preset Speed #1, 67
 Preset Speed #10, 116
 Preset Speed #11, 116
 Preset Speed #12, 116
 Preset Speed #13, 116
 Preset Speed #14, 116
 Preset Speed #15, 116
 Preset Speed #2, 67
 Preset Speed #3, 68
 Preset Speed #4, 68
 Preset Speed #5, 68
 Preset Speed #6, 68
 Preset Speed #7, 68
 Preset Speed #8, 115
 Preset Speed #9, 115
 Preset Speed Direction #1, 132
 Preset Speed Direction #10, 133
 Preset Speed Direction #11, 133
 Preset Speed Direction #12, 133
 Preset Speed Direction #13, 134
 Preset Speed Direction #14, 134
 Preset Speed Direction #15, 134
 Preset Speed Direction #2, 132
 Preset Speed Direction #3, 132
 Preset Speed Direction #4, 132
 Preset Speed Direction #5, 132
 Preset Speed Direction #6, 132
 Preset Speed Direction #7, 133
 Preset Speed Direction #8, 133
 Preset Speed Direction #9, 133
 Preset Speed Mode, 52, 55
 Preset Speeds, 51, 55
 Program Menu Navigation, 48
 Program Mode, 48
 Prohibit Initializing User Parameters During
 Typeform Initialization, 172

Proportional (P) Gain, 128
 Proportional-Integral-Derivative (PID), 128
 Protection Parameters, 52, 53
 PtSt, 183
 Pulse Width Modulation, 14
 PWM Carrier Frequency, 117

Q

Qualified Personnel, 3

R

R, 23, 24
 R Input Terminal Assignment, 72
 R Input Terminal Delay, 83
 R/F Priority Selection, 70
 RAM Fault, 187
 Reach Settings, 50
 Real Time Clock, 212
 Realtime Clock Setup, 48
 Reference Priority Selection, 92
 Regeneration Torque Limit #1, 140
 Regeneration Torque Limit #2, 141
 Regeneration Torque Limit #3, 141
 Regeneration Torque Limit #4, 141
 Regeneration Torque Limit Setting #1, 140
 Release After Run Timer (brake), 167
 Remote EOI Required Hardware, 202
 RES, 23, 24
 RES Input Terminal Assignment, 73
 RES Input Terminal Delay, 83
 Reset, 63
 Retry/Restart Configuration, 52
 Reverse Speed Limit Input, 138
 Reverse Speed Limit Level, 138
 Review Startup Screen, 49
 Ridethrough Mode, 118
 ROM Fault, 187
 Root menu mapping, 44
 Root Menus, 44
 Rotary Encoder, 33
 RR, 23, 24
 RR Bias Adjust, 143
 RR Gain Adjust, 143
 RR Input Speed Control Setup, 97
 RR Input Torque Control Setup, 97
 RR Speed Frequency #1, 98
 RR Speed Frequency #2, 98
 RR Speed Reference #1, 97
 RR Speed Reference #2, 98
 RR Torque Reference Setpoint #1, 98

- RR Torque Reference Setpoint #2, 99
 - RS232, 27
 - RS232/RS485 Baud Rate, 179
 - RS232/RS485 Communications Time Out Time, 176
 - RS232/RS485 Communications Time-Out Action, 176
 - RS232/RS485 Master Output, 180
 - RS232/RS485 Response Delay Time, 179
 - RS232/RS485 Wire Count, 179
 - RS485, 27
 - Run Frequency, 110
 - Run Frequency Hysteresis, 110
 - Run Key, 32
 - RX, 23, 24
 - RX Bias Adjust, 144
 - RX Gain Adjust, 144
 - RX Input Speed Control Setup, 100
 - RX Input Torque Control Setup, 100
 - RX Speed Frequency #1, 101
 - RX Speed Frequency #2, 101
 - RX Speed Reference #1, 100
 - RX Speed Reference #2, 101
 - RX Torque Reference Setpoint #1, 101
 - RX Torque Reference Setpoint #2, 102
 - RX2 Bias Adjust, 144
 - RX2 Gain Adjust, 144
 - RX2 Input Speed Control Setup, 103
 - RX2 Input Torque Control Setup, 103
 - RX2 Speed Frequency #1, 104
 - RX2 Speed Frequency #2, 104
 - RX2 Speed Reference #1, 103
 - RX2 Speed Reference #2, 104
 - RX2 Torque Reference Setpoint #1, 104
 - RX2 Torque Reference Setpoint #2, 105
- S**
- S1, 23, 24
 - S1 – S4 Input Terminal Delay, 83
 - S1 Input Terminal Assignment, 73
 - S2, 23, 24
 - S2 Input Terminal Assignment, 73
 - S3, 23, 24
 - S3 Input Terminal Assignment, 73
 - S4, 23, 24
 - S4 Input Terminal Assignment, 74
 - S5 – S16 Input Terminal Delay, 83
 - S5 Input Terminal Assignment, 74
 - S6 Input Terminal Assignment, 74
 - S7 Input Terminal Assignment, 75
 - Scrolling Monitor, 44
 - Scrolling Monitor Select, 58
 - Service Life Information, 10
 - Shipping Weight, 190
 - Short Circuit Detect Pulse, 53
 - Short Circuit Test, 164
 - Short Circuit Test Duration, 164
 - Sink/Source Setting Error, 187
 - Soft Stall, 66
 - Soft Stall Enable, 53
 - Soft Start, 53
 - Spare Parts Listing, 213
 - S-pattern 1, 148
 - S-pattern 2, 148
 - S-Pattern Lower Limit Adjustment, 149
 - S-Pattern Upper Limit Adjustment, 149
 - Special Control Parameters, 58
 - Special Parameters, 59
 - Speed at Drooping Gain 0%, 122
 - Speed at Drooping Gain 100%, 122
 - Speed Drop Detection Frequency Range, 165
 - Speed Limit (torque) Reference, 139
 - Speed Limit Torque Level, 139
 - Speed Limit Torque Range, 139
 - Speed Limit Torque Recovery, 139
 - Speed Loop Integral Gain, 131
 - Speed Loop Parameter Ratio, 131
 - Speed Loop Proportional Gain, 131
 - Speed Reach Frequency, 69
 - Speed Reach Frequency Tolerance, 69
 - Speed Ref. Setpoint, 51
 - Speeds, 55
 - splash screen display, 28
 - ST, 23, 24
 - ST Input Terminal Assignment, 73
 - ST Input Terminal Delay, 83
 - ST Signal Selection, 70
 - ST1, 18
 - Stall, 52
 - Stall Cooperation Gain at Field Weakening Zone, 145
 - Stall Prevention During Regeneration, 142
 - Standard Mode Settings, 48
 - Startup and Test, 22
 - Startup Frequency, 109
 - Startup Wizard, 48
 - Startup Wizard Requirements, 36
 - Status LED, 32
 - Stop Key, 32
 - Stop Pattern, 173
 - SW1, 26
 - SW2, 26
 - Switching Frequency of Current/Voltage Control, 146
 - Switching Load Torque During Forward-Run, 125
 - Switching Load Torque During Reverse-Run, 125
 - Synchronized Torque Bias Input, 137
 - System Grounding, 20
 - System Integration Precautions, 8
 - System Operation, 34

T

T1/U, 21
 T2/V, 21
 T3/W, 21
 Tension, 137
 Tension Torque Bias Input, 137
 Terminal Descriptions, 24
 Terminal Selection Parameters, 50
 Torque Boost Adjustment, 169
 Torque Command, 136
 Torque Command Filter, 136
 Torque Command Mode, 139
 Torque Control, 53
 Torque Limit Group, 173
 Torque Limit Mode, 141
 Torque Limit Mode (Speed Dependent), 142
 Torque Limit Settings, 54
 Torque Proving Fault, 187
 Torque Setting Parameters, 53, 54
 Torque Speed Limiting, 54
 Trip History, 57, 188
 Trip Monitor From ASD, 189
 Trip Monitor from ASD, 57, 58
 Trip Record at Monitor Screen, 189
 Trip Save at Power Down Enable, 161
 Trip Settings, 53
 Trips, 181
 Trouble Shooting, 181
 TTL Master Output, 177
 Type Reset, 49, 63
 Typeform Error, 187

U

U Phase Short Circuit, 187
 UC, 183
 UL 1995, 190
 Undervoltage Detection Time, 166
 Undervoltage Stall level, 166
 Undervoltage Trip, 166
 Undervoltage/Ridethrough, 53
 Up Key, 32

Upper Deviation Limits, 128
 Upper Limit Frequency, 36, 64
 Upper Limit Frequency Adjustment, 168
 Use Speed Mode, 131
 User Notification Codes, 184
 User Notification codes, 181
 Utility Parameters, 49

V

V Phase Short Circuit, 187
 V/f Adjustment, 59
 V/f Adjustment Coefficient, 89
 V/f Five Point Setting, 59
 V/f Group, 172
 V/f Pattern, 65
 Vector Motor Model, 57
 Vector Motor Model Autotune Command, 134
 Vector Motor Model Slip Frequency Gain, 134
 Versions, 49
 VI, 23, 25
 VI/II Bias Adjust, 143
 VI/II Gain Adjust, 143
 VI/II Input Speed Control Setup, 93
 VI/II Input Torque Control Setup, 93
 VI/II Speed Frequency #1, 94
 VI/II Speed Frequency #2, 94
 VI/II Speed Reference #1, 93
 VI/II Speed Reference #2, 94
 VI/II Torque Reference Setpoint #1, 94
 VI/II Torque Reference Setpoint #2, 95
 Viewing Trip Information, 188
 Voltage and Frequency Rating of the Motor, 36
 Voltage Compensation Coefficient for Dead Time, 146
 Voltage Vector Control, 145
 Volts per Hertz Setting, 37

W

W Phase Short Circuit, 187
 Warranty Card, 4
 Wizard Finish, 38