

TOSVERT VF-AS1/PS1

---

PB unit Option  
( PB7-4200K / 4400K )  
( PB7-6300K / 6400K )  
Instruction Manual

---







## I . Safety precautions





The items described in these instructions and on the inverter itself are very important. Read these precautions and warnings to prevent injury to yourself and other people around you as well as prevent damage to property in the area.

**Thoroughly familiarize yourself with all safety precautions and etc. on the instruction manual of the VF-AS1/PS1**, and then continue to read the manual. Make sure that you observe all warnings given.

### ■ General Operation

 <b>Warning</b>	
 Disassembly prohibited	<ul style="list-style-type: none"> <li>▼ Never disassemble, modify or repair. This can result in electric shock, fire and injury. For repairs, call your sales agency.</li> </ul>
 Prohibited	<ul style="list-style-type: none"> <li>▼ Never remove the front cover when power is on or open door if enclosed in a cabinet. The unit contains many high voltage parts and contact with them will result in electric shock.</li> <li>▼ Don't stick your fingers into openings such as cable wiring hole and cooling fan covers. This can result in electric shock or other injury.</li> <li>▼ Don't place or insert any kind of object into the inverter (electrical wire cuttings, rods, wires). This can result in electric shock or fire.</li> <li>▼ Do not allow water or any other fluid to come in contact with the inverter. This can result in electric shock or fire.</li> </ul>
 Mandatory	<ul style="list-style-type: none"> <li>▼ Wiring must be done after turning off all input power to the VF-AS1/PS1.</li> <li>▼ If the inverter begins to emit smoke or an unusual odor, or unusual sounds, immediately turn power off. If the equipment is continued to operate in such a state, the result may be fire. Call your local sales agency for repairs.</li> </ul>

### ■ Transportation & installation

 <b>Warning</b>	
 Prohibited	<ul style="list-style-type: none"> <li>▼ Do not install or operate the inverter if it is damaged or any component is missing. This can result in electric shock or fire. Please consult your local sales agency for repairs.</li> <li>▼ Do not place any inflammable objects nearby. If a flame is emitted due to malfunction, it may result in a fire.</li> <li>▼ Do not install in any location where the inverter could come into contact with water or other fluids. This can result in electric shock or fire.</li> </ul>
 Mandatory	<ul style="list-style-type: none"> <li>▼ Must be used in the environmental conditions prescribed in the instruction manual. Use under any other conditions may result in malfunction.</li> </ul>
 <b>Caution</b>	
 Prohibited	<ul style="list-style-type: none"> <li>▼ Do not install in any area where the unit would be subject to large amounts of vibration. That could result in the unit falling, resulting in injury.</li> </ul>

## ■ Wiring

### Warning

 Mandatory	<ul style="list-style-type: none"> <li>▼ The following steps must be performed before wiring.             <ol style="list-style-type: none"> <li>(1) Turn off all input power to the inverter.</li> <li>(2) Wait at least 15 minutes and check to make sure that the charge lamp of the VF-AS1/PS1 is no longer lit.</li> <li>(3) Use a tester that can measure <sup>*1</sup>DC voltage 800VDC or more, and check to make sure that the voltage to the DC main circuits (between PA and PC) is 45V or less.</li> </ol> <p>If these steps are not properly performed, the wiring will cause electric shock.</p> </li> <li>▼ Tighten the screws on the terminal board to specified torque. If the screws are not tightened to the specified torque, it may lead to fire.</li> </ul>
--	---

\*1) In case of 690V inverter, use a tester of DC voltage 1400VDC or more.

## ■ Operations

### Warning

 Prohibited	<ul style="list-style-type: none"> <li>▼ Do not touch inverter and option unit terminals when electrical power is applied to the inverter even if the motor is stopped. Touching the inverter terminals while power is connected to it may result in electric shock.</li> <li>▼ Do not touch switches when hands are wet and do not try to clean the inverter with a damp cloth. Such practices may result in electric shock.</li> <li>▼ Do not pull the cable. This can result in damage or malfunction.</li> </ul>
---	--

## ■ Disposal

### Caution

 Mandatory	<ul style="list-style-type: none"> <li>▼ If you throw away this product, have it done by a specialist in industry waste disposal*. If the collection, transport and disposal of industrial waste is done by someone who is not licensed for that job, it is a punishable violation of the law. (Laws in regard to cleaning and processing of waste materials) (* )Persons who specialize in the processing of waste and known as “industrial waste product collectors and transporters” or “industrial waste disposal persons”.</li> </ul>
--	--

---

## II . Introduction

---

Thank you for your purchase of the PB unit option (called the PB unit after this) for the inverter “TOSVERT VF-AS1/PS1”.

This PB unit is the separate dynamic braking unit to use with the inverter “TOSVERT VF-AS1/PS1”.

Before using the PB unit, read this manual and refer to the instruction manual of the pairing inverter, after that use it appropriately.

**- Contents -**

I. Safety precautions	1
II. Introduction	3
1. Read first	5
2. Names, specifications and dimensions	6
3. Standard connections	8
4. Installation	9
5. Set parameters	15
6. Replacement of expendable parts	17
7. Warranty	17

# 1. Read first

## ■ Check product purchase

Before using the product you have purchased, check to make sure that it is exactly what you ordered.

[Check the accessories]

This PB unit option is composed of PB unit and following accessories.

Unpack a parcel and check to make sure the contents.

○Instruction manual : This manual

○Bus bars for connecting the BU terminals :

Parts (B) in this manual, see page 10, 12 and 13

○Cover of DC choke chassis : Parts (E) in this manual, see page 11 (PB7-4200K only)

○Screw for connecting PB unit

[Check the name plate]

The name plate is put on the left-hand side of the PB unit on the position of figure below.

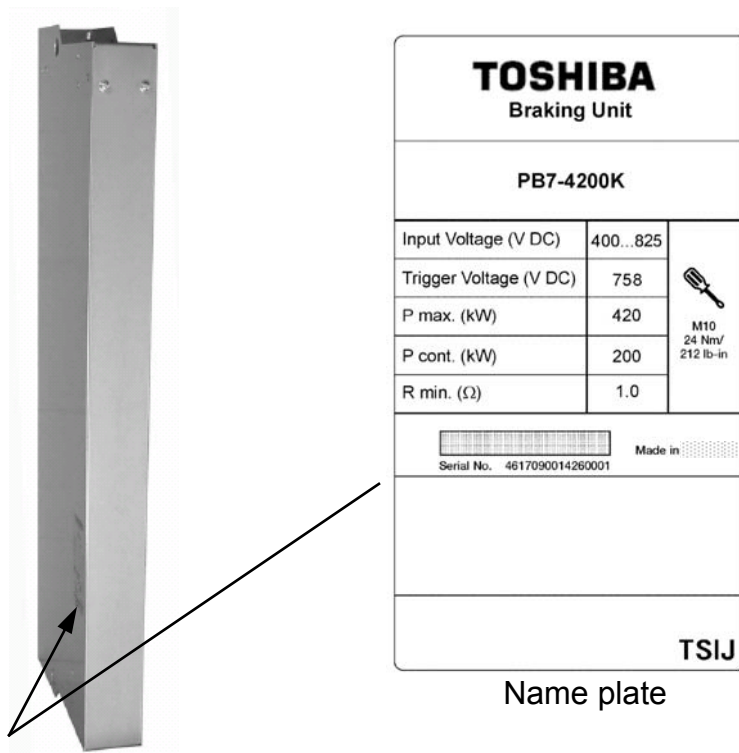

PB unit Type

Input Voltage (DC)

threshold Voltage

Maximum braking power

Maximum continuous power

Minimum allowable resistance

Name plate

[ Contents of the product ]

Explanation of the type and form written on the label.

P	B	7	-	4	2	0	0	K
Model name	Voltage class	Regenerative braking capacity						

## 2. Names, specifications and dimensions

### ■ Specifications

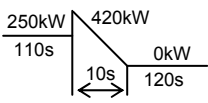
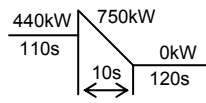
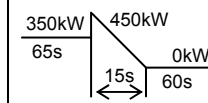
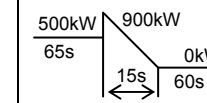
PB unit type	PB7-4200K	PB7-4400K	PB7-6300K	PB7-6400K
threshold voltage (note2)	758V (at F626=134)		1090V (at F626=134)	
Maximum DC bus voltage	825V		1170V	
Maximum braking power at threshold voltage	420kW-12s	750kW-12s	450kW-7s	900kW-7s
Maximum continuous power	200kW	400kW	300kW	400kW
% ED	5% - 420kW	5% - 750kW	5% - 450kW	5% - 900kW
	15% - 320kW	15% - 550kW	15% - 400kW	15% - 600kW
	50% - 250kW	50% - 440kW	50% - 350kW	50% - 500kW
cycle time	240 second or less		140 second or less	
Braking power on a vertical movement				
Protective function (note1)	overheat protection, overcurrent protection, overheat protection for AC fan (PB7-4400K, 6300K, 6400K)			
Minimum allowable resistance	1.0Ω	0.7Ω	2.0Ω	1.0Ω
Ambient temperature	-10 to +50 °C			
Storage temperature	-25 to +70 °C			
Relative humidity	20 to 93 % (free from condensation)			
Vibration	5.9m/s <sup>2</sup> {0.6G} or less (10 to 55Hz)			
Protective method	IP00 Open type			
Calorific values	550W	1050W	650W	1150W
Forced ventilation	3.2m <sup>3</sup> /min	6.0m <sup>3</sup> /min	3.7m <sup>3</sup> /min	6.6m <sup>3</sup> /min
Color	RAL9006 (German standard)	RAL7016 (German standard)		
Installation position	mount closely on the left-hand side of the inverter	mount on the left-hand side of the inverter		
Approx weight	30kg	80kg		

note1) When each protective functions are detected, the alarm is outputted from the inverter main unit.

note2) Threshold voltage can be adjusted using the inverter parameter F626.

## ■ Outline drawing

VFAS1-4200KPC ~4280KPC/  
(VFPS1-4250KPC~4315KPC)  
+ DCL1-4200K, 4280K  
+ PB7-4200K

PB7-4400K, -6300K, 6400K

note) (1),(2) of below figure are  
the dimensions of  
(1) with the screws and (2) without the screws

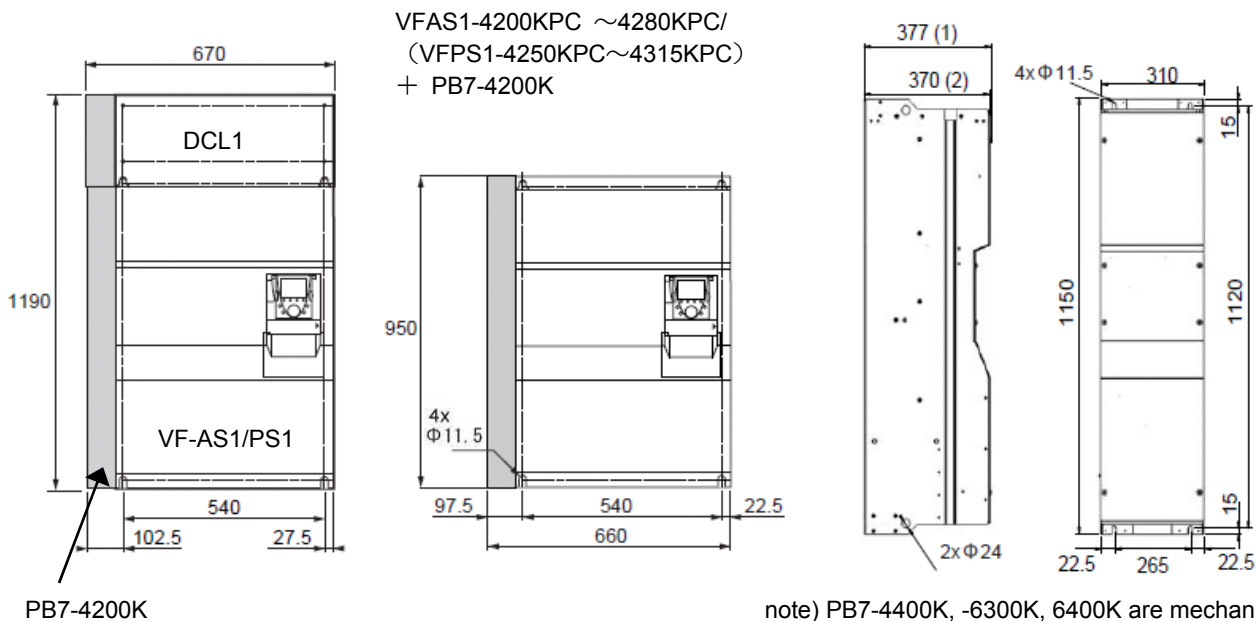

note) PB7-4400K, -6300K, 6400K are mechanically  
mounted on the wall or the bottom of an enclosure  
on the left of the inverter VF-AS1/PS1, and must be  
placed 110mm ( $\pm 5$ mm) from the inverter.

## ■ Selection of braking resistor

Standard braking resistors and recommended wire size are listed in the table below.

	PB7-4200K	PB7-4400K
VFAS1-4200KPC, 4220KPC	Rating : 8.7kW – 1.9Ω PA, PB terminal : 60mm <sup>2</sup>	-
VFAS1-4280KPC VFPS1-4250KPC 4280KPC 4315KPC	Rating : 14kW – 1.4Ω PA, PB terminal : 60mm <sup>2</sup> (PS1-4315KPC : 100 mm <sup>2</sup> )	-
VFAS1-4355KPC, 4400KPC VFPS1-4400KPC	-	Rating : 17.4kW – 0.95Ω PA, PB terminal : 100mm <sup>2</sup> G/E terminal : 60mm <sup>2</sup>
VFAS1-4500KPC VFPS1-4500KPC 4630KPC	-	Rating : 28kW – 0.7Ω PA, PB terminal : 150mm <sup>2</sup> G/E terminal : 100mm <sup>2</sup>

Maximum cable length between the PB unit and the braking resistor is 50m.

Refer to the specifications (page 6 of this manual) for minimum allowable resistance value of braking resistor.

Note) The recommended wire size is that of the wire with continuous maximum permissible temperature of 75 °C, ambient temp is 50 °C or less and the wiring distance is 30m or less.

### 3. Standard connections

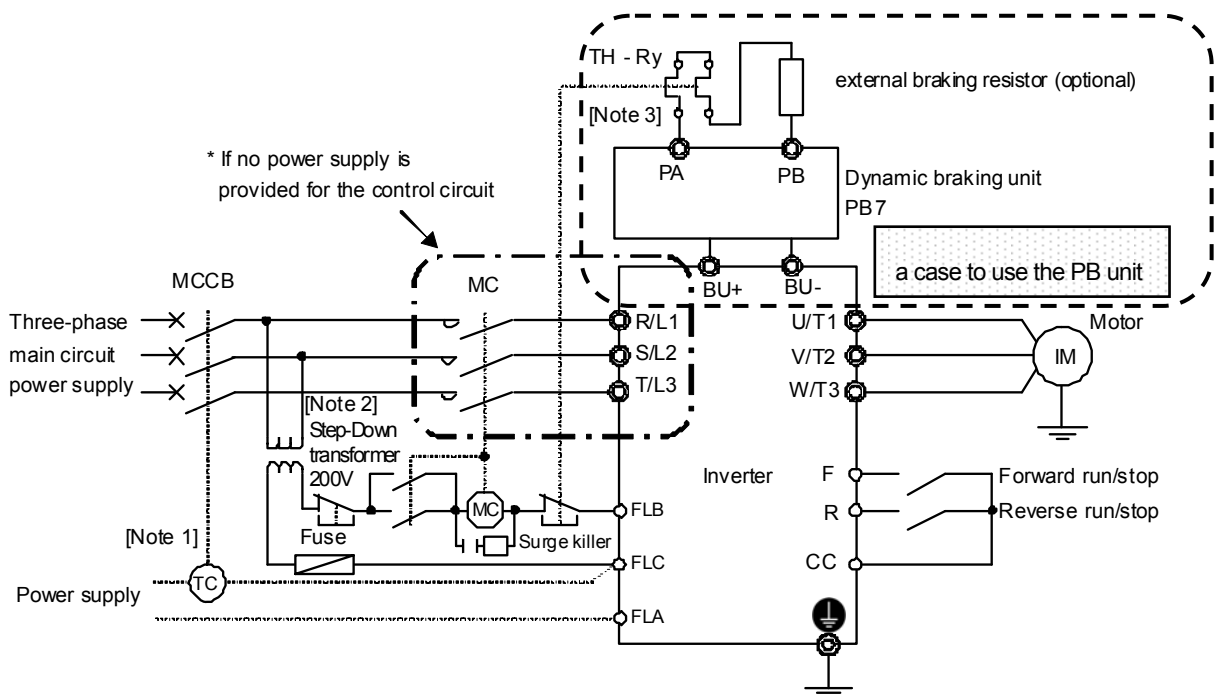

Note 1: Connection when using a MCCB with a top coil instead of a MC.

Note 2: A Step-Down transformer is required for 400V/690V models but not for 200V models.

Note 3: As a last resort to prevent fire, be sure to connect a thermal relay (TH-Ry).

Select and connect a thermal relay (TH-Ry) appropriate to the capacity (Wattage) of the braking resistor.

[Position of terminals]

PB7-4200K

PB7-4400K, -6300K, -6400K

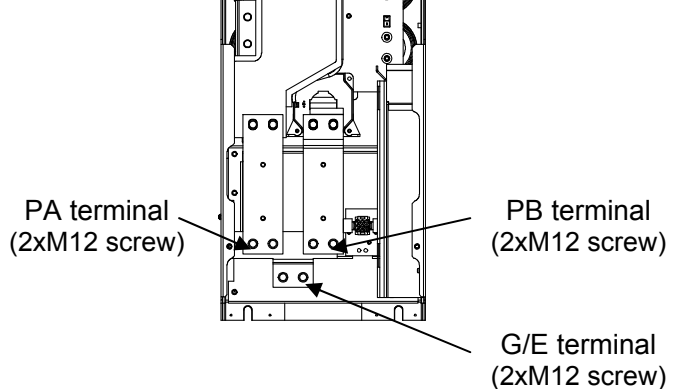
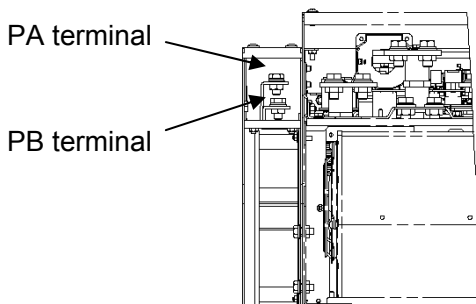
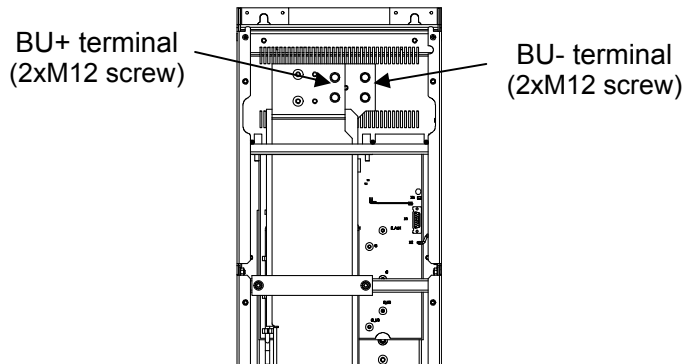
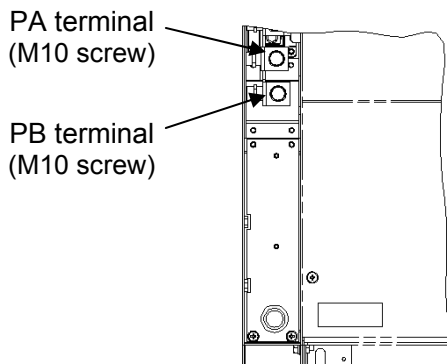

## 4. Installation

Show below about how to connect between PB7 unit and VF-AS1/PS1, and installation environment.

● Applicable inverter

	VFAS1	VFPS1
PB7-4200K	-4200KPC, -4220KPC -4280KPC	-4250KPC, -4280KPC -4315KPC
PB7-4400K	-4355KPC, -4400KPC -4500KPC	-4400KPC, -4500KPC -4630KPC
PB7-6300K	-6200KPC, -6250KPC -6315KPC	-6250KPC, -6315KPC -6400KPC
PB7-6400K	-6400KPC, -6500KPC -6630KPC	-6500KPC, -6630KPC

PB7-4200K is mechanically mounted on the left-hand side of the inverter VF-AS1/PS1.

PB7-4400K, -6300K, -6400K are mechanically mounted on the wall or the back of an enclosure on the left of the inverter VF-AS1/PS1, and must be placed 110mm ( $\pm 5$ mm) from the inverter.

After the mechanical installation of PB unit, connect the bus bars and each cables between the inverter and the PB unit.

### ■ How to connect between PB7-4200K and VF-AS1/PS1

1. Mechanically install the VF-AS1/PS1.
2. Remove the cover of VF-AS1/PS1 in accordance with the safety instructions given in this document.
3. Detach removable part (A) from the left-hand side of the VF-AS1/PS1.

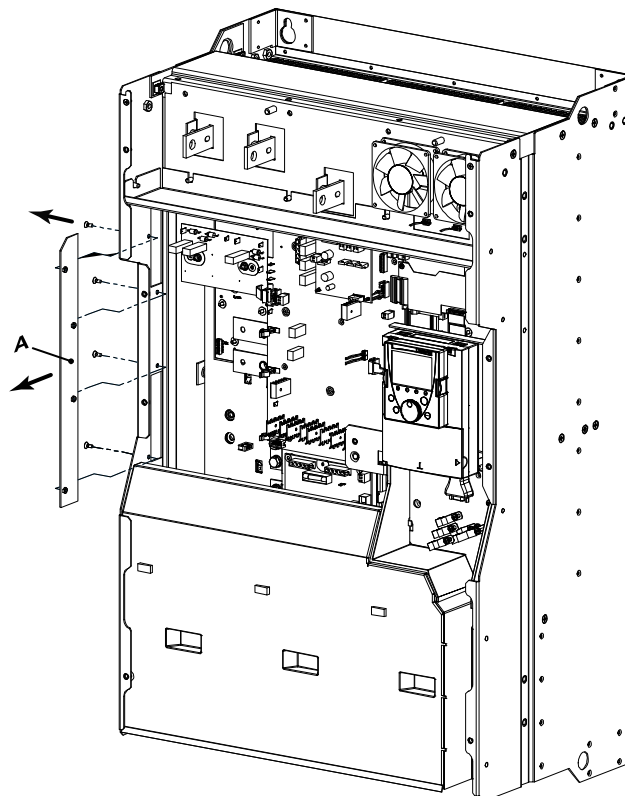

4. Mount the PB7-4200K on the left-hand side of the VF-AS1/PS1.  
There are 5 fixing points (5xM8).

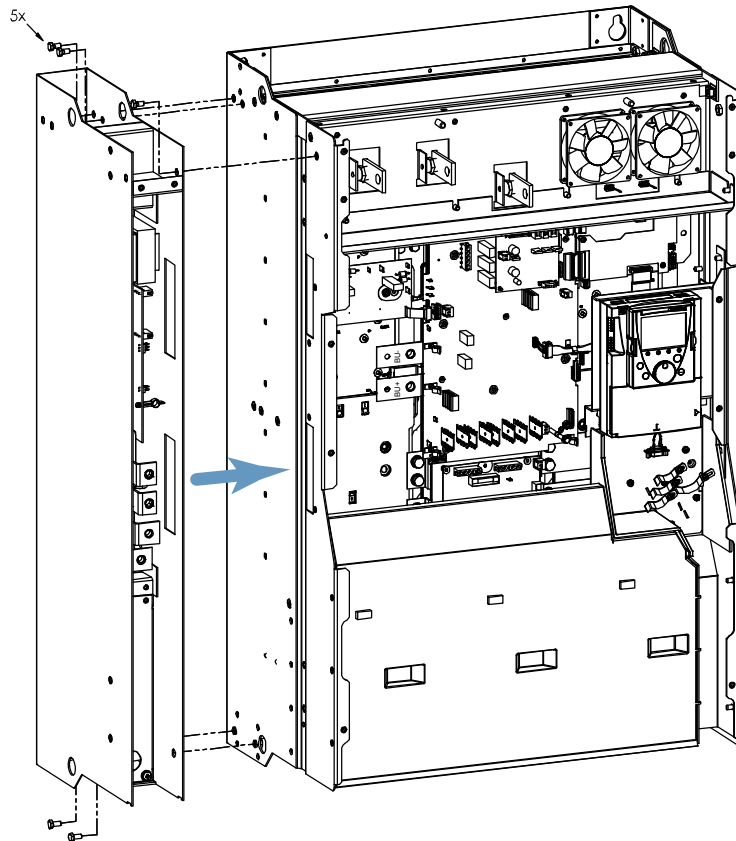

5. Connect the bus bars (B) between terminals BU- and BU+ on the VF-AS1/PS1 and terminals BU- and BU+ on the PB7-4200K.  
6. Connect the braking resistor to PA and PB terminals on the PB7-4200K.

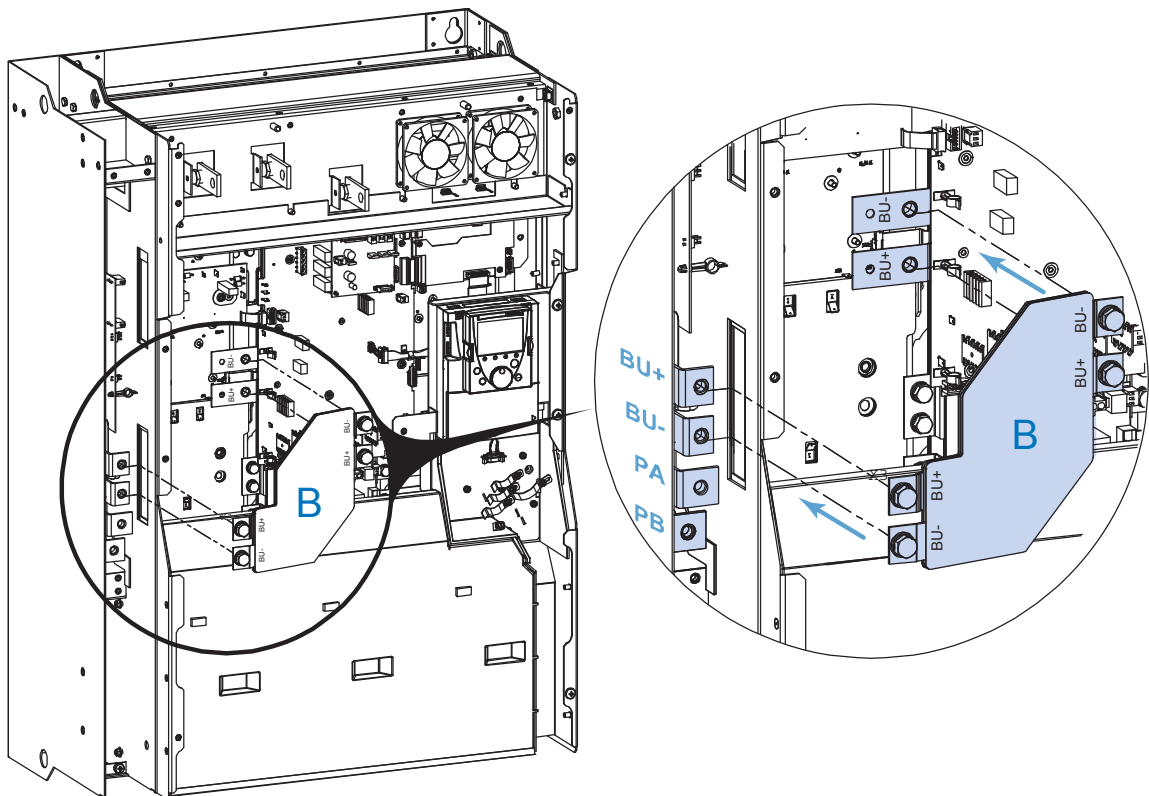

### 7. Connect the control cables:

- Connect control cable X20 on the PB7-4200K to cable X20 on the VF-AS1/PS1.
- Connect control cable X92 on the PB7-4200K to connector X92 on the VF-AS1/PS1.
- Disconnect cable X3 on the VF-AS1/PS1 from connector X3 on the PCBA of the VF-AS1/PS1.
- Connect disconnected cable X3 to cable X3B on the PB7-4200K.
- Connect cable X3A on the PB7-4200K to connector X3 on the PCBA of the VF-AS1/PS1.

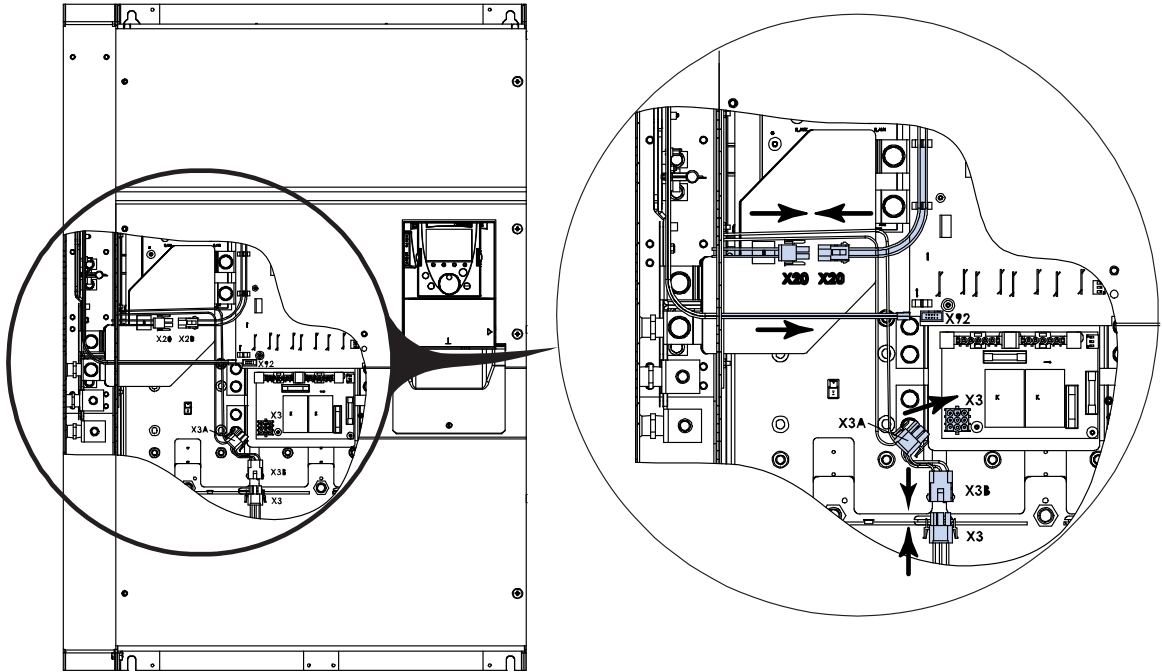

(The following is the case when use with DC choke option.)

8. Mount the DC choke chassis (C) on the wall or on the bottom of the enclosure.  
Refer to the attached installation manual of DC choke option.
9. Detach removable part (D) from DC choke chassis.
10. Mount the PB7-4200K cover (E) on the DC choke chassis.
11. Install the DC chokes in accordance with the installation manual of DC choke option.

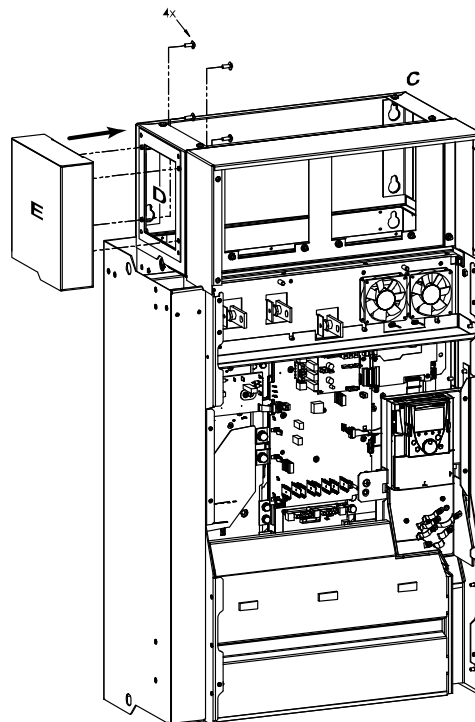

■ **How to connect between PB7-4400K, -6300K, -6400K and VF-AS1/PS1**

1. Mechanically install the VF-AS1/PS1 and the PB7 unit.
2. Remove the cover of VF-AS1/PS1 in accordance with the safety instructions given in this document.
3. Detach removable part (A) located inside the VF-AS1/PS1.
4. Connect the bus bars (B) between terminals BU- and BU+ on the VF-AS1/PS1 and terminals BU- and BU+ on the PB7 unit.

PB7-4400K

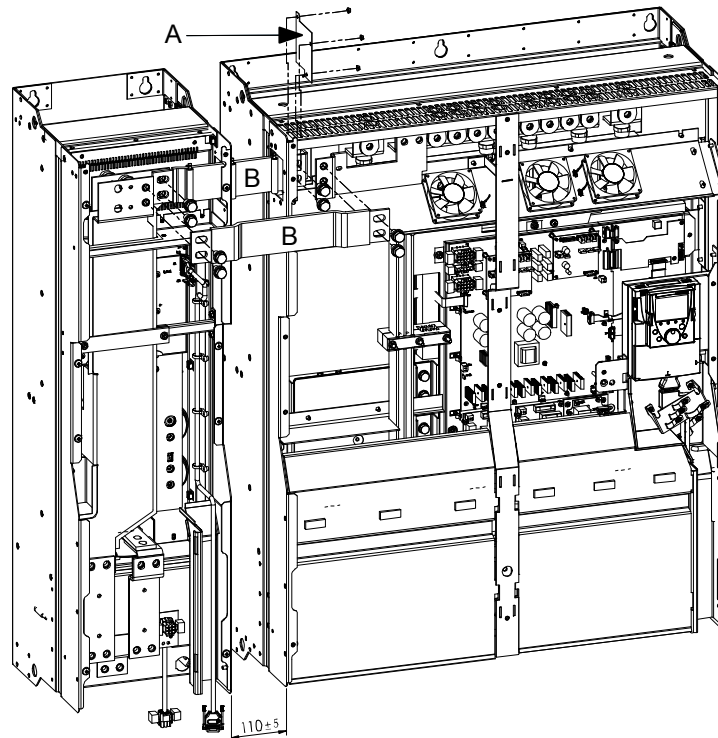

PB7-6300K

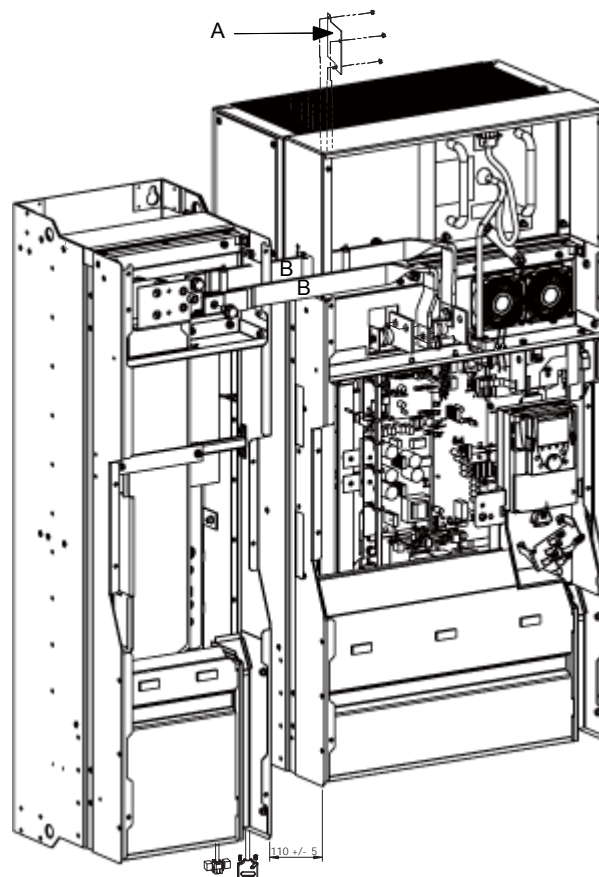

PB7-6400K

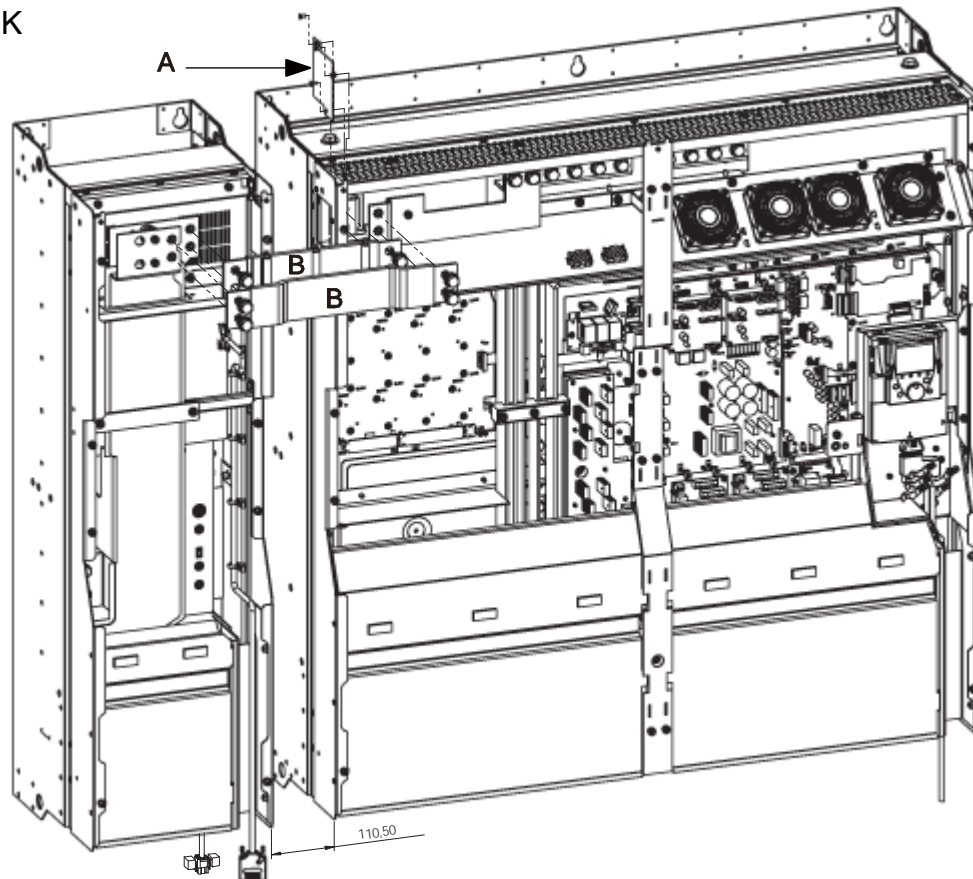

5. Connect the each cables:

- Connect the X1 control cable from the PB7 unit to the X1 connector on the VF-AS1/PS1 via the control cable hole.
- Connect the fan power supply cable from the PB7 unit to the connector X2 on the VF-AS1/PS1.

PB7-4400K

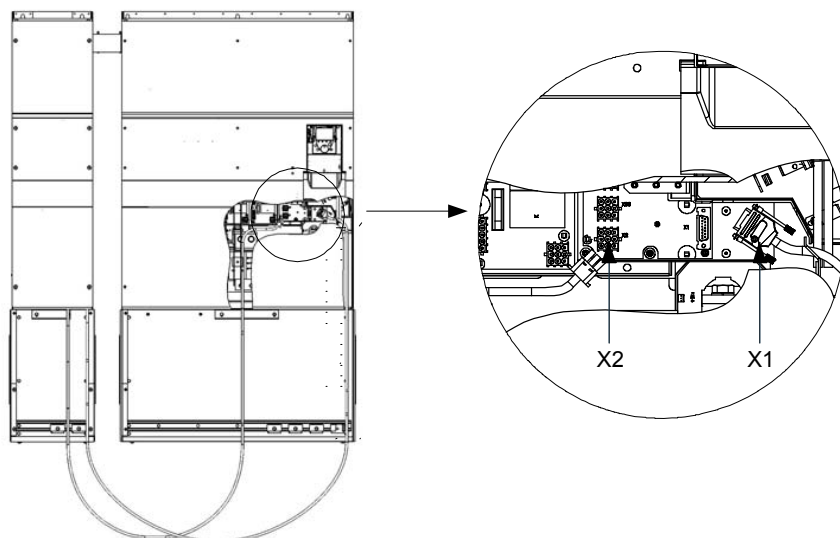

PB7-6300K

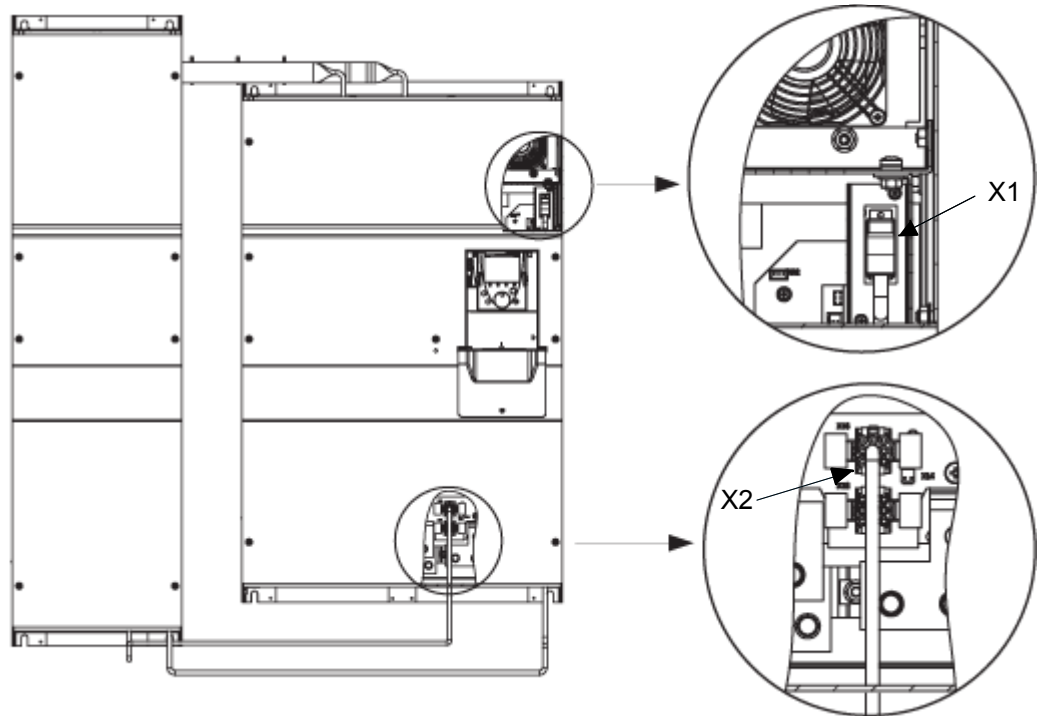

PB7-6400K

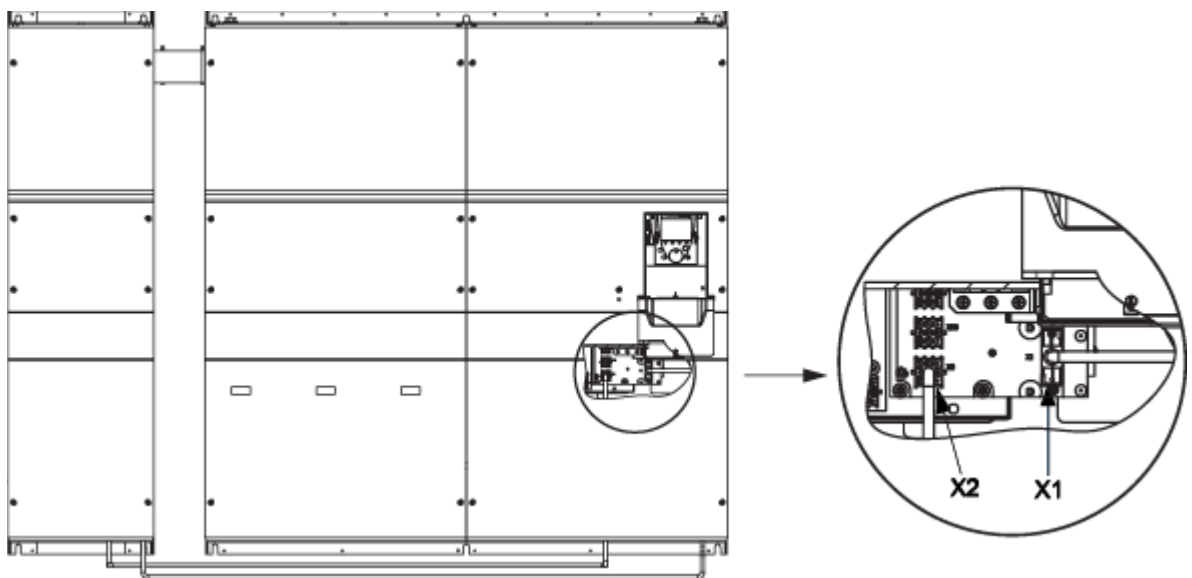

## ■ Installation environment

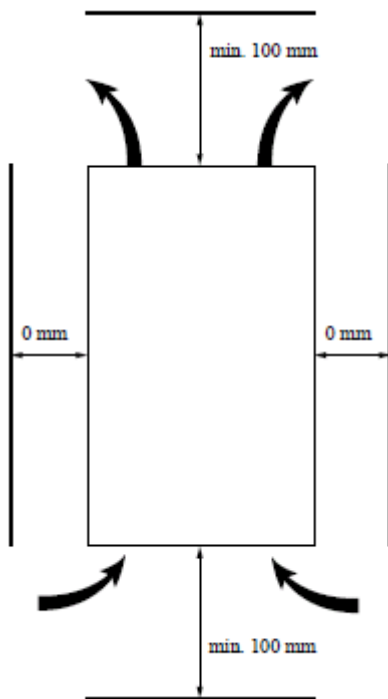

Install the PB unit in a well-ventilated indoor place and mount in portrait orientation.

As PB unit uses a built-in cooling fan, at least leave a space of 100mm or more above and below the PB unit.

note) Do not install in any location where there is high humidity or high temperatures and where there are large amounts of dust and metallic fragments. If you are going to install the equipment in any area that presents a potential problem, please consult with your supplier before doing so.

## 5. Set parameters

Set parameters of the inverter after installation the PB unit. Refer to instruction manual of the VF-AS1 (E6581301 or E6581442 or E6581528) VF-PS1(E6581386 or E6581531) section 5.19 about how to set parameters.

### [Parameter setting]

Title	Function	Adjustment range				Default setting
$P_b$	Dynamic braking selection note1), note2)	Setting	Braking function	ST-off	Overload detect	0
		0	Disabled	—	—	
		1	Enabled (It is effective in trip condition.) The state of $OLr$ trip is excluded.	Enabled	protect	
		2			not protect	
		3		Disabled	protect	
		4	not protect			
		5	Enabled (It isn't effective in trip condition )	Enabled	protect	
		6			not protect	
		7		Disabled	protect	
8	not protect					
$P_{br}$	Dynamic braking resistance	0.5~1000 $\Omega$				According to inverter model
$P_{bCP}$	Dynamic braking resistor capacity	0.01~600.0 kW				According to inverter model
$F626$	Overvoltage limit operation level (Regenerative braking level)	100~150% note3)				134
$F639$	Braking resistance overload time	0.1~600.0 sec.				5.0

Note1)  $P_b$  is set to 1 or more when PB unit is used.

And set  $F305$  ( Overvoltage limit operation) to 1.

Note2)  $P_b = 3$  to 8 is available only for inverter software version 152 or more (VFAS1), 652 or more (VFPS1).

Note3) When PB unit is used,  $F525$  setting is recommended in the table below.

model	Inverter line supply (AC)	$F525$ recommended range
PB7-4200K PB7-4400K	380V/400V	112% to 145%
	440V	123% to 145%
	460V	129% to 145%
	480V	134% to 145%
PB7-6300K PB7-6400K	500V	113% to 150%
	575V	113% to 144%
	690V	113% to 120%

---

## 6. Replacement of expendable parts

---

The PB unit is composed of a large number of electronic parts including semiconductor devices. The following parts deteriorate with the passage of time because of their composition or physical properties. The use of aged or deteriorated parts leads to degradation in the performance or a breakdown of the equipment. To avoid such trouble, the PB unit should be checked periodically.

note) Generally, the life of a part depends on the ambient temperature and the conditions of use. The life spans listed below are applicable to parts when used under normal environmental conditions.

### 1) Cooling fan

The fan, which cools down heat-generating parts, has a service life of about 10 years (average ambient temperature : 40°C, operation time : 12 hours per day). The fan also needs to be replaced if it makes a noise or vibrates abnormally.

### 2) Smoothing capacitor (for PB7-4400K, 6300K, 6400K)

The smoothing aluminum electrolytic capacitor in the main circuit DC section degrades in performance because of ripple current, etc. It becomes necessary to replace the capacitor after it is used for about 5 years under normal conditions (average ambient temperature : 40°C, load factor : not more than 80%, operation time : 12 hours per day).

note) When it becomes necessary to replace expendable parts, contact your supplier. For safety's sake, never replace any part on your own.

---

## 7. Warranty

---

Any part of the PB unit that proves defective will be repaired and adjusted free of charge under the following conditions:

1. Any part of the PB unit which fails or is damaged under normal installation and use within 1 year from the date of delivery shall be repaired free of charge.
2. This warranty applies only to the PB unit option main unit.
3. For the following kinds of failure or damage, the repair cost shall be borne by the customer even within the warranty period.
  - a) Failure or damage caused by improper or incorrect use or handling, or unauthorized repair or modification of the PB unit
  - b) Failure or damage caused by the PB unit falling or an accident during transportation after the purchase
  - c) Failure or damage caused by fire, salty water or wind, corrosive gas, earthquake, storm or flood, lightning, abnormal voltage supply, or other natural disasters
  - d) Failure or damage caused by the use of the PB unit for any purpose or application other than the intended one
4. Unless a service contract is signed beforehand between the customer and Toshiba, in which case the service contract has priority over this warranty.