

INSTRUCTION MANUAL

PULSE INPUT TERMINAL BLOCK BOARD

VF5X-4575 (INTERNAL)
TOSVERT VF-A5 OPTION

[Toshiba inverter VF5X-4575 input terminal manual](#)

Thank you for purchasing the "Pulse Input Terminal Block Board".

Before using the board, read and understand this manual with reference to the inverter's instruction manual to use the product properly. After reading the manual, store it in a safe place.

Request to a built-up manufacturer:

Please make sure that this manual is delivered to a person who will actually use the inverter unit. Be sure to read this manual before connecting and operating the inverter unit.

TOSHIBA CORPORATION

I. Preface

Thank you for purchasing the “Pulse Input Terminal Block Board”(VF5X-4575) for Toshiba general purpose inverter TOSVERT VF-A5.

Before using the “Pulse Input Terminal Block Board”, read this manual carefully with reference to the inverter unit’s instruction manual to take advantage of the excellent performance of the product.

The user of the “Pulse Input Terminal Block Board” should keep this manual and refer to it for maintenance and inspection.

Items Provided with this Product

The following items should be included when this product is purchased. Contact your Toshiba dealer if any items are missing.

- 1) Pulse input terminal block board (VF5X-4575) x 1
- 2) Instruction manual x 1

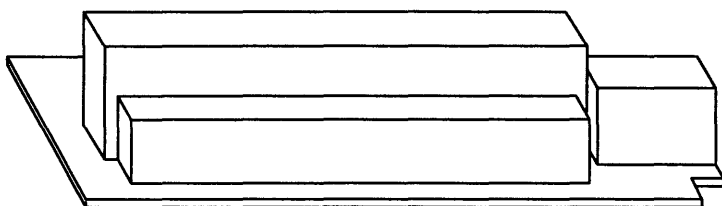

Pulse input terminal block board



Instruction manual

Features

The inverter VF-A5 will have the following two additional functions with the board mounted.

- 1) Pulse input (frequency setting signal)
- 2) PG speed feedback control

NOTE:The board has different terminal layout from the standard terminal block board (VF5C-4511A).

Outline of the board

This board is different from the VF-A5's standard terminal block board (VF5C-4511A) in the following configurations.

- 1) Does not have a terminal connector CN6X connected to the expansion terminal block boards (VF5X-4514, 4515).
- 2) Does not have a S4 terminal.
- 3) The terminal layout is different from that of the standard terminal block board (VF5C-4511A).

Pulse input terminal block board VF5X-4575

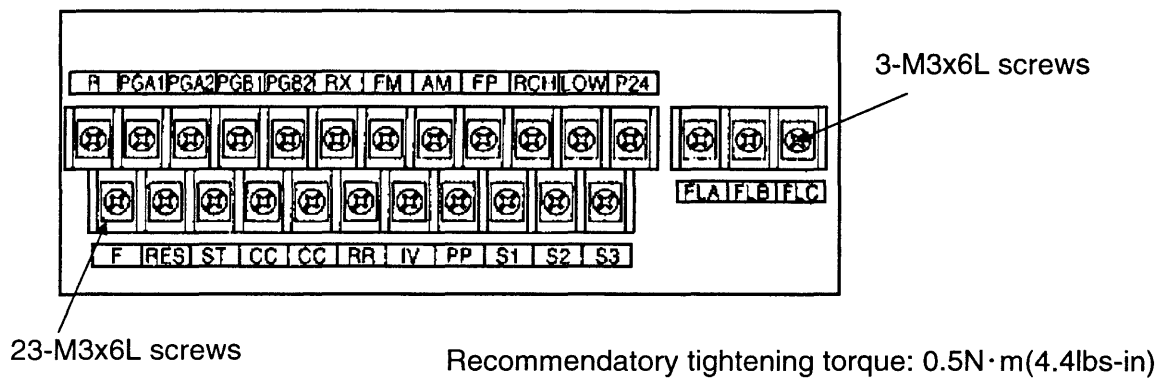

Standard terminal block board VF5C-4511A

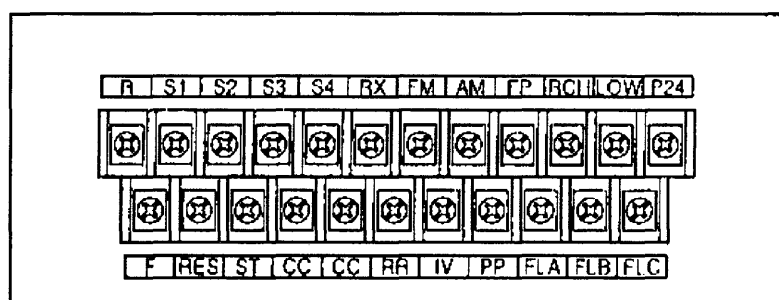

Restrictions on Use

■ Applicable inverters

This board can be used for the following inverters.

VFA5-2004P to 2900P

VFA5-4007P to 4280KP

■ Use with other optional boards

The following built-in type options can be used with this board. For use of any options, you are requested to purchase them separately.

Options	Model
12-bit binary input board	VF5X-4526A
RS485 communication board	VF5X-4524A
TOSLINE-F10M communication board	VF5X-1254A
TOSLINE-S20 communication board	VF5X-1255A

NOTE: This board cannot be used with the expansion terminal block boards (VF5X-4514 and 4515).

II. Safety

Important safety information is provided, both on the inverter itself and in its manual to operate this product safely and to prevent loss to property and danger to personnel, both the actual operator as well as others. Read safety precautions described in the inverter's instruction manual and follow the instructions.

Before reading the main sections of this manual, be sure you fully comprehend the following safety displays, figures and symbols, and follow the associated instructions whenever using or working with or near this product.

IMPORTANT MESSAGES

Read this manual and follow its instructions. Signal words such as CAUTION, and NOTE will be followed by important safety information that must be carefully reviewed.

▲CAUTION : Indicates a potentially hazardous situation which if not avoided, may result in minor injury or moderate injury.

NOTE: Gives you helpful information.

Handling

▲CAUTION :

Mounting or removing the board while the panel displays is illuminated can result in electric shock.

Before mounting or removing the board, switch off the inverter input power source (via the breaker on the power distribution panel) and check that the inverter panel is unlit.

See page 1

Contents

I. Preface.....	i
II. Safety.....	iv
Contents.....	v
1. Installation.....	1
2. Functional Description.....	2
2.1 Pulse Input (Frequency setting).....	2
2.1.1. Pulse Input Specifications.....	2
2.1.2. Pulse Input Connection Procedure.....	3
2.1.3. Pulse Input Setup Procedure.....	5
2.2. PG Speed Feedback Control Using Pulse Input.....	6
2.2.1. PG Speed Feedback Control Specifications.....	6
2.2.2. Procedures for PG Speed Feedback Control Connections.....	6
2.2.3. Setup Procedures for PG Speed Feedback Control.....	10
2.2.4. Block diagram and calculations of PG speed feedback control.....	11

1. Installation

This board is to be mounted on the position where standard terminal block board is mounted in VF-A5 inverter. Replace the standard terminal block board with this VF5X-4575 board following the procedures below. When the board has already been installed in the inverter at your purchase, replacement is not necessary.

▲CAUTION :

Mounting or removing the board while the panel displays is illuminated can result in electric shock.

Before mounting or removing the board, switch off the inverter input power source (via the breaker on the power distribution panel) and check that the inverter panel is unlit.

1. Switch off the inverter input power source (via the breaker on the power distribution panel), and check that the inverter operation panel is unlit.
2. Remove the inverter cover.
3. Disconnect the flat cable, that is connected to the control board, from the connector CN2A on the standard terminal block board (1).
4. Remove the lock screw (2) and take off the standard terminal block board (1).
5. Fit the new VF5X-4575 board as shown in the enlarged view Figure 1-1.
6. Tighten the screw (2) again and fix the board.
7. Insert the flat cable into the connector CN2A on the new board.
8. Switch on the input power source (inverter power) and check that the display "0.0" or "nOFF" is shown. If the flat cable is connected wrong, "OFF" display will appear. In that case switch off the inverter input power and connect the flat cable again after the display on the inverter panel disappeared.

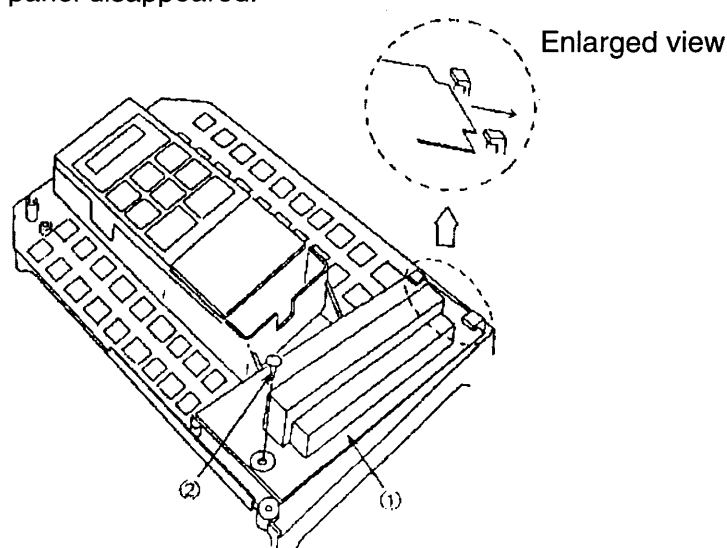

Figure 1-1 Reference drawing for installation

2. Functional Description

This section describes the additional functions of the board VF5X-4575 besides those of the standard functions of VF-A5.

2.1 Pulse Input (Frequency setting)

The inverter operating frequency command can be set from a pulse signal input.

■ Application examples

- (1) The inverter output frequency can be controlled to be proportional to the frequency of a pulse output signal from a pulse generator.
- (2) When using a pulse generator, forward and reverse operation is possible by inputting the pulse of two phases (A and B) that have 90-degree phase difference.

2.1.1. Pulse Input Specifications

Table 2-1 Pulse input specifications

Item	Single-phase	Two-phase
Maximum pulse input frequency	120kHz or less	60kHz or less
Pulse input voltage	12Vdc to 18Vdc (for VF5X-4575A)	
Speed control	±0.1% or less	

2.1.2. Pulse Input Connection Procedure

- ◆ Use twisted shield wire for signal connection.
- ◆ Never bind the signal wire and the main circuit wire together.
- ◆ Recommendatory wire diameter is 0.75mm².

■ For Single-Phase Pulse Input Signal Operation

- (1) Connect the pulse input signal between the terminals PGA1 and PGA2 or between PGB1 and PGB2.
- (2) The polarity of the pulse input signal should be:
 - + side ...PGA1 or PGB1
 - side ...PGA2 or PGB2
- (3) Changeover of the forward and reverse operation is possible when the command mode is valid for terminal input (parameter *CNOd* of *Cr.Ut* is 1) among the terminals ST, F, R and CC.

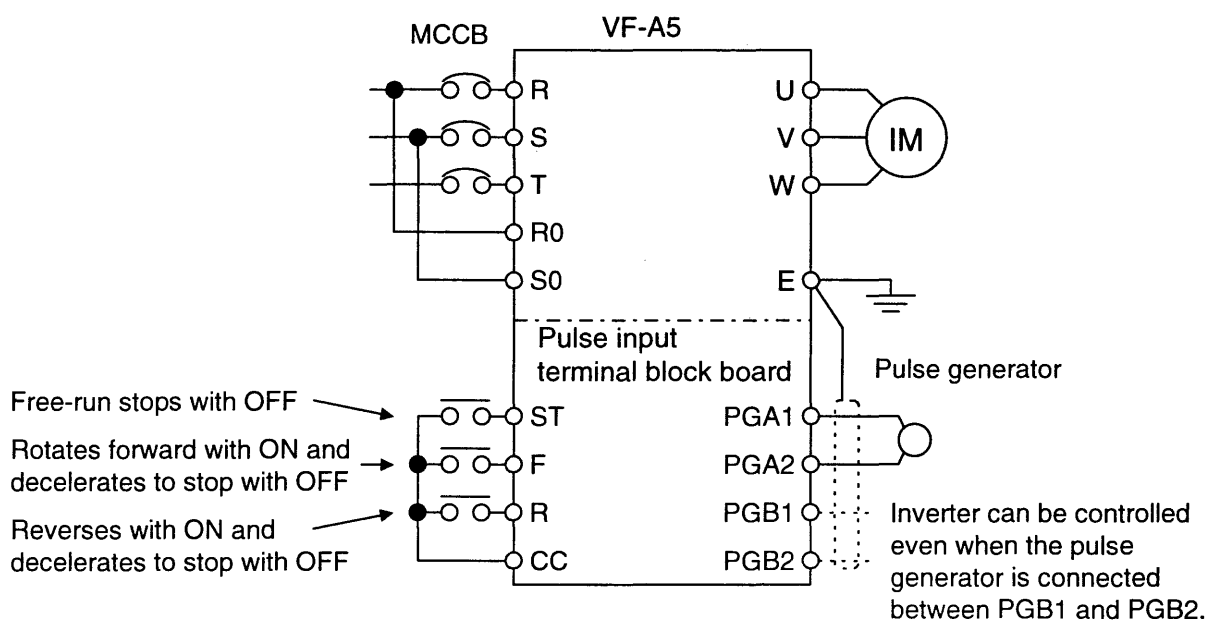

Reverses when both F and R are ON.

Figure 2-1

Connection diagram when using a pulse generator for controlling inverter's operation frequency with a single-phase pulse signal

■ For Two-Phase Pulse Input Signal Operation

- (1) For connecting pulse input signals, connect phase A between the terminals PGA1 and PGA2 and phase B between the terminals PGB1 and PGB2.
- (2) The polarity of the pulse input signal should be:
 - + side ... PGA1 and PGB1
 - side ... PGA2 and PGB2
- (3) A discrimination circuit determines forward or reverse operation as well as the operating frequency command by the pulse of the two phases (phases A and B) from the pulse generator.
- (4) Discrimination of forward and reverse direction is determined by the train of pulses as shown in the figure 2-2.

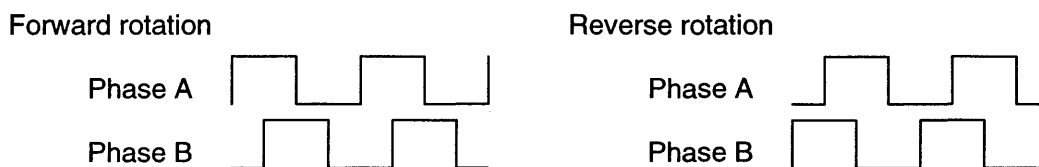
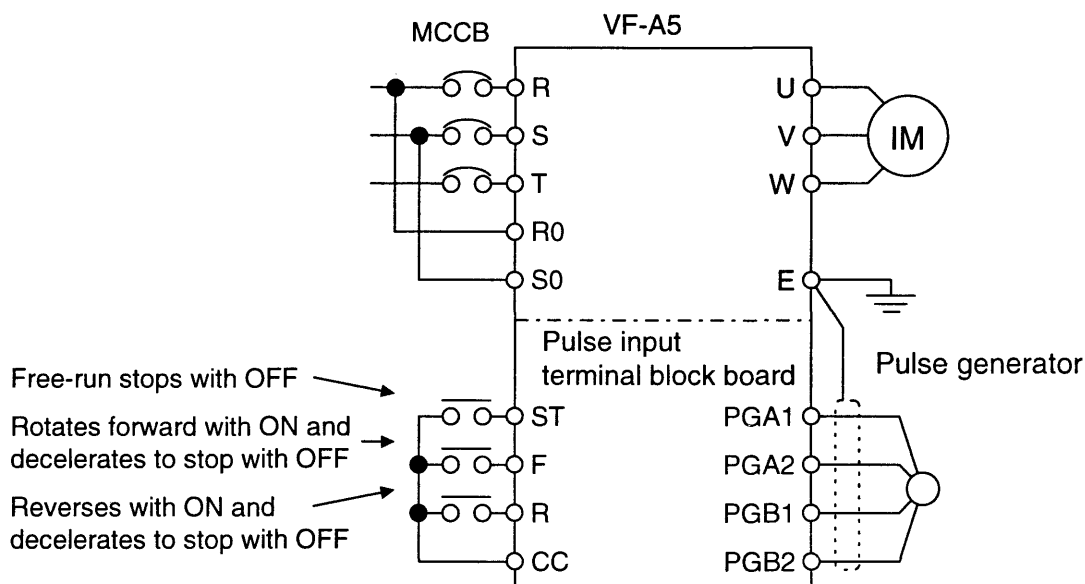

Figure 2-2 Discrimination of forward and reverse rotation judging by the train of pulses of two phases (A and B)



Reverses when both F and R are ON.

Figure 2-3 Connection diagram when using a pulse generator for controlling inverter's operation frequency with two-phase pulse signals

2.1.3. Pulse Input Setup Procedure

Table 2-2 Parameters necessary for setting the pulse input

Parameter group	Parameter	Function	Set value	Initial value
Gr.Fb	PG	PG input pulse count *1	1 to 9999	500
	PGPH	Selecting number of PG input phases	1:Single-phase input 2:Two-phase input	2
Gr.SF	FC1	Frequency priority selection 1	4:PG pulse input setup	1
	PGIn	PG input	1:Adjustment *2	0
	P7	PG point 1 set signal *3	-100 to 100	0
	F-P7	PG point 1 frequency *3	-FH to FH *4	0.0
	P8	PG point 2 set signal *3	-100 to 100	100
	F-P8	PG point 2 frequency *3	-FH to FH *4	80.0
Gr.Ut	FNOd	Selecting frequency setting mode	1: Terminal input is valid	4

*1: The number of PG input pulses (PG) means the number of pulses per one revolution. Operational frequency command value of the inverter is represented by the following formula.

$$\text{Frequency command value} = \frac{\text{Pulse input frequency}}{PG}$$

*2: By setting 1 for $PGIn$, blinded parameters $P7$, $F-P7$, $P8$ and $F-P8$ will be displayed.

*3: For adjustment of Gain and Bias relative to the pulse input frequency, see figure 2-4.

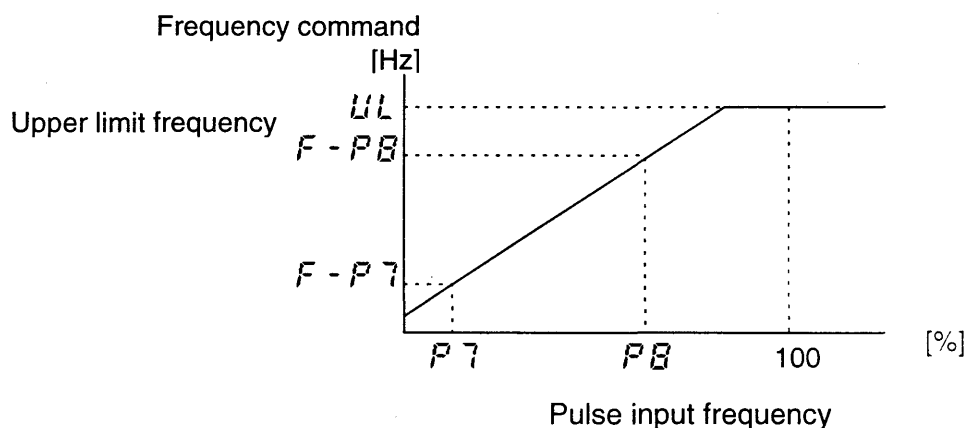

Figure 2-4 Pulse input frequency and frequency command value

*4: FH is the maximum frequency. (Parameter group: Gr.F)

2.2. PG Speed Feedback Control Using Pulse Input

This application performs speed feedback control in which motor speed fluctuations due to load variations are corrected using a pulse train feedback signal from an encoder mounted on either the motor shaft or a rotating shaft in the load.

The system can provide a motor speed control precision with respect to the set frequency of better than 0.1% (60Hz base).

2.2.1. PG Speed Feedback Control Specifications

Table 2-3 PG speed feedback control specifications

Specification		Single-phase	Two-phase
Maximum pulse input frequency		120 kHz or less	60kHz or less
Pulse input voltage		12Vdc to 18Vdc (for VF5X-4575A)	
Speed control		±0.1% or less	
Applicable encoder	Output method	<ul style="list-style-type: none"> • Open collector output • Complimentary output 	
	Maximum output pulse	120 kHz or less	60 kHz or less
Recommendatory encoder		Manufacturer: Sumtak Corporation Type: LBJ series Power supply: 12V or 15V* Output method: Complimentary output	

*: Prepare external power source.

2.2.2. Procedures for PG Speed Feedback Control Connections

- ◆ Use twisted shield wire for signal connection.
- ◆ Never bind the signal wire and the main circuit wire together.
- ◆ Recommendatory wire diameter is 0.75mm².

■ When the pulse input signal is a single-phase:

- (1) Connect the pulse input signal between the terminals PGA1 and PGA2 or between PGB1 and PGB2.
- (2) Connection terminals will differ depending on the method of the encoder output.

Encoder output method		Pulse input terminal block board
Complimentary		<p>or</p>
Open collector		

(3) Changeover of the forward and reverse rotation is possible when the command mode is valid for terminal input (parameter *ENOD* of *Gr.Ut* is 1) among the terminals ST, F, R and CC.

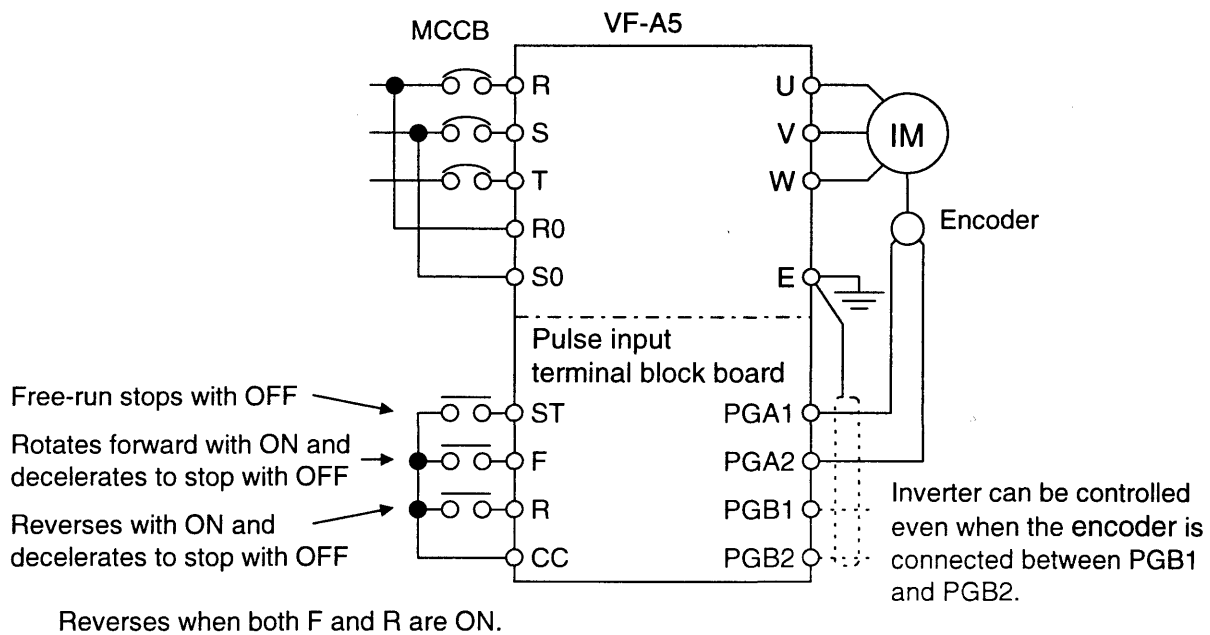

Figure 2-5 Connection diagram when using an encoder for controlling speed feedback with a single-phase pulse input signal

■ When the pulse input signal is a two-phase:

- (1) For connecting pulse input signals, connect phase A between the terminals PGA1 and PGA2 and phase B between the terminals PGB1 and PGB2.
- (2) Connection terminals will differ depending on the method of the encoder output.

Encoder output method		Pulse input terminal block board
Complimentary		
Open collector		

*: When 0V is divided at phases A and B, remove the short-circuit between PGA2 and PGB2 and connect 0V wire of phase B at the terminal shown with the dotted line.

- (3) A discrimination circuit determines the rotating direction (forward or reverse) as well as the operating frequency command by the pulse of the two phases (phases A and B) from the encoder.
- (4) Discrimination of forward and reverse direction is determined by the train of pulses as shown in the figure 2-6.

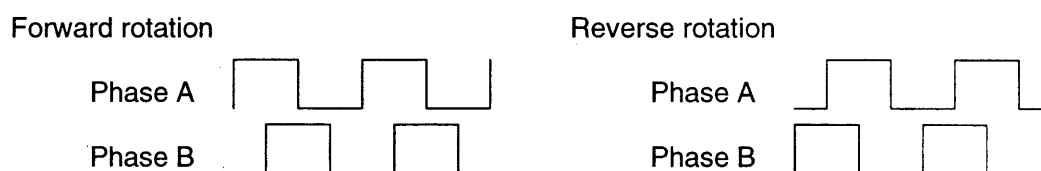
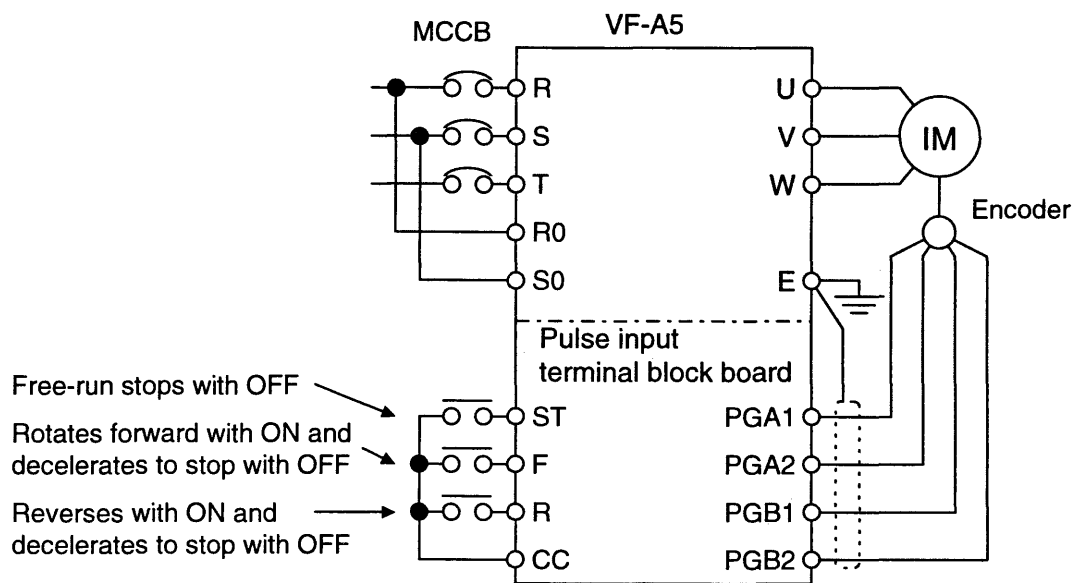

Figure 2-6 Discrimination of forward and reverse rotation judging by the train of pulses of two phases (A and B)



Reverses when both F and R are ON.

Figure 2-7 Connection diagram when using an encoder for controlling speed feedback with a two-phase pulse input signal

■ Procedures for PG Speed Feedback Control Connections When replacing the SV-PACK

- (1) For connecting pulse input signals, connect phase A between the terminals PGA1 and PGA2 and phase B between the terminals PGB1 and PGB2.
- (2) Provide 12Vdc electricity to the encoder from the external power source.
- (3) Be sure to connect the shield grounding of the encoder output cable to the N line of the power source.

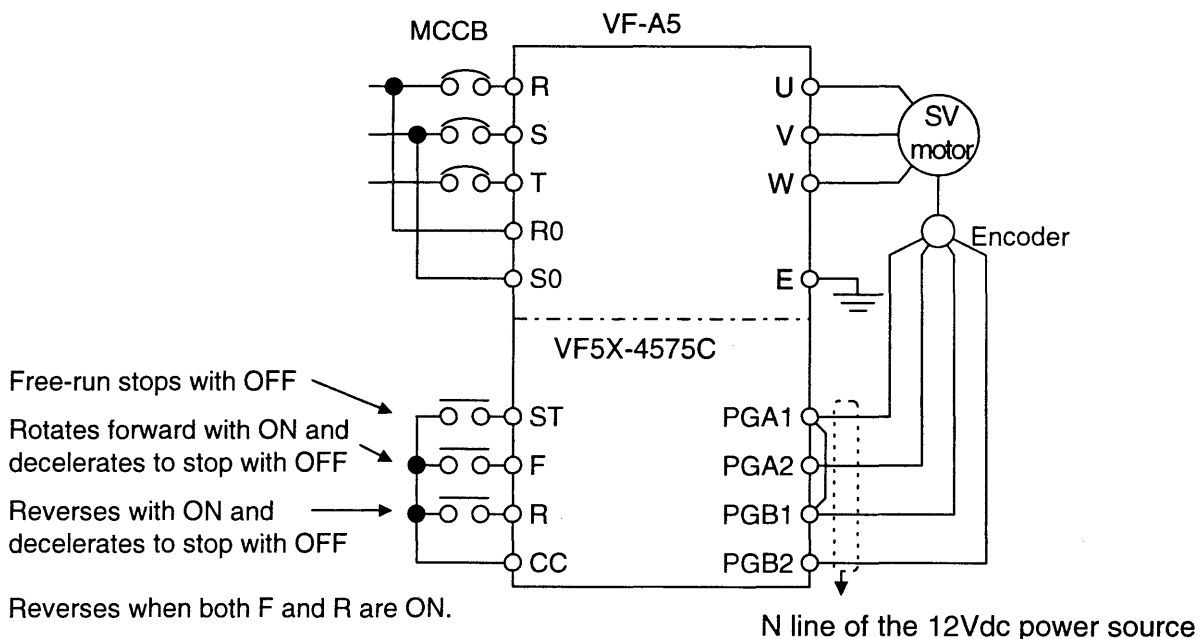

Figure 2-8 Connection diagram when replacing the SV-PACK

2.2.3. Setup Procedures for PG Speed Feedback Control

Table 2-4 Parameters necessary for setting PG speed feedback control

Parameter group	Parameter	Function	Set value	Initial value
Gr.Fb	FbP1	Feedback control selection	2: Speed feedback control	0
	Fbin	Feedback input signal selection	4: PG feedback	2
	GP	Proportional gain *1	0.01 to 255	0.30
	GI	Integration time *1	0.01 to 360.0	5.00
	GR	Differentiation time *1	0.0 to 25.5	0.0
	GFS	Delay filter *1	0 to 255	80
	PG	PG input pulse count *2	1 to 9999	500
Gr.SF	PGPH	Selecting number of PG input phases *3	1: Single-phase input 2: Two-phase input	2
	FC1	Frequency priority selection 1 *4	Except 4	1
	FC2	Frequency priority selection 2 *4	Except 4	2
Gr.Nt	NtP	Number of motor poles	2 to 16	4

*1: Adjust four parameters while running the inverter as described below.

- ◆ GP (Proportional gain) is a coefficient multiplied by the deviation (the difference between the set frequency value and the feedback). The proportional control action provides a correction that is proportional to this deviation.
- ◆ GI (Integration time) eliminates the deviation (remaining deviation offset) that accumulates in the proportional control. By counting the integration time of the offset adjustment continues until the offset is completely eliminated.
- ◆ GR (Differentiation time) determines operation that improves the response time. However, note that increasing this value increases the system's sensitivity to noise, and may result in large fluctuations in the output frequency.
- ◆ GFS (Delay filter) diminishes the rapid changes caused by the differentiation. Normally this does not have to be changed.

[When hunting occurs during test run with the value of standard factory settings, lessen the GR (differential time). If it is not effective, increase the GI (integration time) and lessen the GP (proportional gain).

*2: PG(number of PG input pulses) represents the number of pulses per one revolution.

*3: When the PG pulse input signal is a single-phase, do not select 2 (two-phase) for PGPH (PG input phase), or else the motor will run fast or reverse.

*4: Do not set the value 4 (PG pulse input) for the FC1 and FC2.

2.2.4. Block diagram and calculations of PG speed feedback control

■ Block diagram

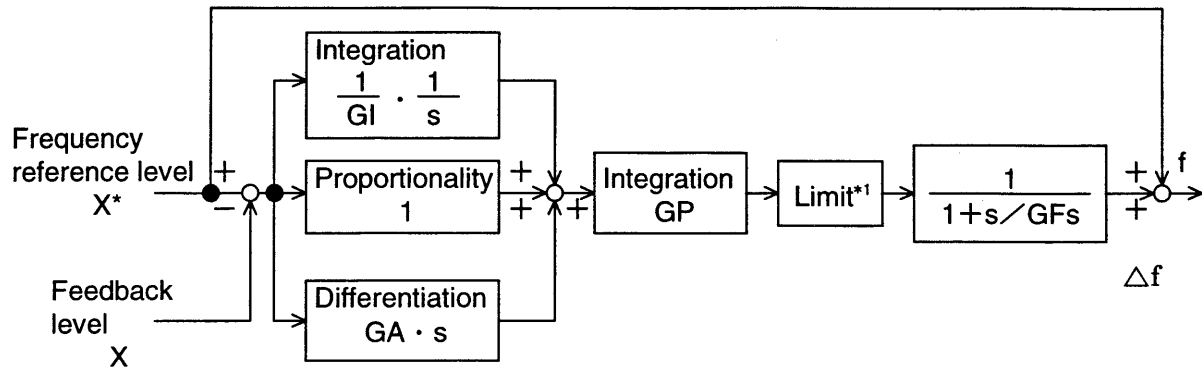

*1: Maximum frequency $FH \times 12.5\%$.

■ Calculation formula

$$\Delta f = \frac{1}{1+s/GFs} \times GP \left\{ (X^* - X) + \left(\frac{1}{GI} \right) \int (X^* - X) dt + GA \left(\frac{d(X^* - X)}{dt} \right) \right\}$$