TOSVERT VF-AS1

PID control Instruction Manual

Toshiba Schneider Inverter Corporation

The technical information in this manual is provided to explain the principal functions and applications of the product, but not to grant you a license to use the intellectual property or any other property of Toshiba Schneider Inverter Corporation or a third party.

- CONTENTS -

1. PID CONTROL FUNCTION.....	2
1.1. PID control block diagram.....	2
1.2. Parameters for PID control function.....	3
1.2.1. Parameters for PID control function	3
1.2.2. Maximum frequency	5
1.2.3. Upper limit frequency.....	5
1.2.4. Specifying the feedback value	5
1.2.5. Specifying the process value	7
1.2.6. Acceleration/deceleration time	9
1.2.7. Upper limit frequency, lower limit frequency and jump frequency	9
1.2.8. Override processing	9
1.2.9. Operation starting frequency	9
1.2.10. Switching to open loop operation	9
1.2.11. Resetting the integral gain and differential gain set for PID control	10
2. ADJUSTING PID CONTROL GAINS.....	11
2.1.1. Adjusting the proportional (P) gain	11
2.1.2. Adjusting the integral (I) gain.....	12
2.1.3. Adjusting the differential (D) gain	12
2.1.4. Adjusting the delay filter	12
2.1.5. Adjusting the PID deviation upper limit.....	12
2.1.6. Adjusting the PID deviation lower limit	13
2.1.7. Adjusting the target upper limit	13
2.1.8. Adjusting the target lower limit.....	13
2.1.9. Adjusting the PID start waiting time.....	13
2.1.10. Adjusting the PID output upper limit	13
2.1.11. Adjusting the PID output lower limit.....	13
2.1.12. Adjusting the increase and decrease rates of the target value	14
2.1.13. Converting the units of the process value and feedback value	14
2.2. Adjusting the analog command voltage	15

1. PID control function

The VF-AS1 has two types of PID control functions. By setting parameters, a type of PID control can be selected between process PID control which is performed gently in response to changes in temperature or pressure and speed PID control, such as speed control of a winder, which is performed at high speed in response to changes in speed.

1.1. PID control block diagram

Here are block diagram showing the outline of PID control.

[Process PID control (F359=1)]

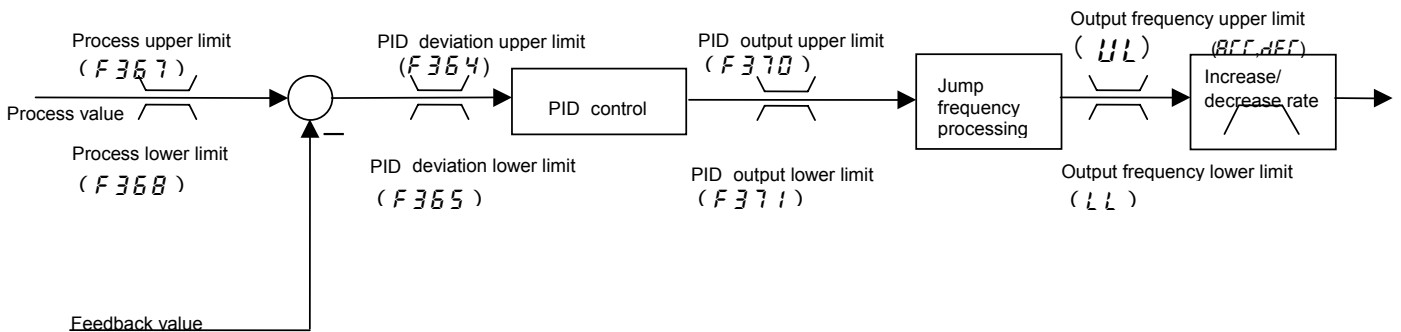

[Speed PID control (F359=2)]

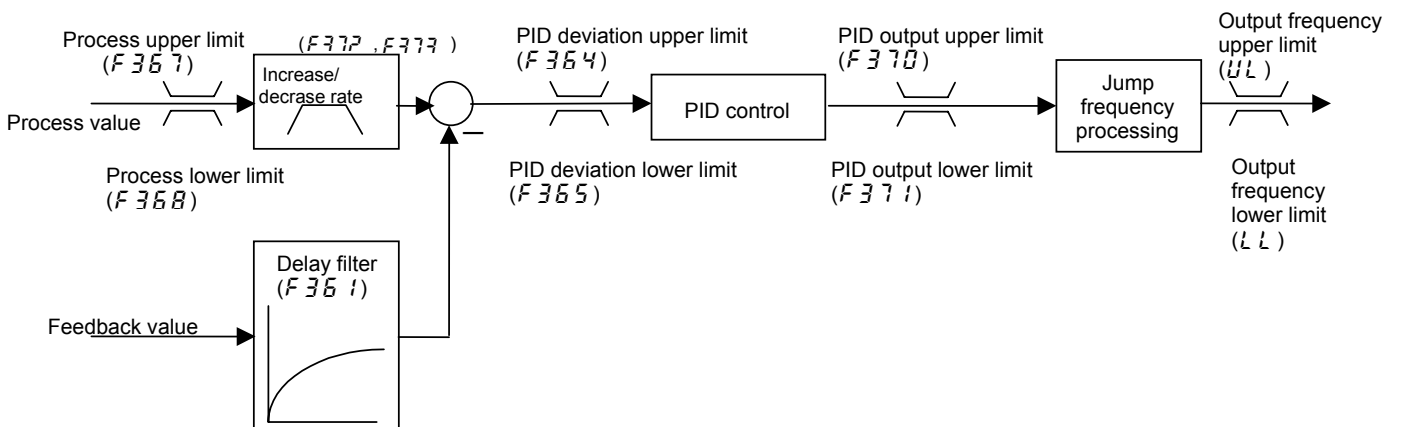

1.2. Parameters for PID control function

1.2.1. Parameters for PID control function

• The table below lists the parameters that need to be set for PID control.

Title	Function	Adjustment range	Default setting
<i>FNDd</i>	Frequency setting mode selection 1	1: VI/II (voltage/current input) 2: RR/S4 (potentiometer/voltage input) 3: RX (voltage input) 4: Operation panel input enabled (including LED/LCD panel option input) 5: Operation panel RS485 (2-wire) communications input 6: Internal RS485 (4-wire) communications input 7: Communications option input 8: Option AI1 (differential current input) 9: Option AI2 (voltage/current input) 10: UP/DOWN frequency 11: RP pulse input 12: High-speed pulse input 13: Binary/BCD input	2
<i>FH</i>	Maximum frequency	30.0~500.0 (Hz)	80.0
<i>UL</i>	Upper limit frequency	0.0~ <i>FH</i> (Hz)	60.0
<i>LL</i>	Lower limit frequency	0.0~ <i>LL</i> (Hz)	0.0
<i>ACC</i>	Acceleration time 1	0.1~6000 (sec.)	Depends on the capacity
<i>DEC</i>	Deceleration time 1	0.1~6000 (sec.)	Depends on the capacity
<i>F207</i>	Frequency setting mode selection 2	Same as <i>FNDd</i> (1~13)	1
<i>F240</i>	Operation starting frequency	0.0~ <i>FH</i> (Hz)	0.1
<i>F241</i>	Operation starting frequency hysteresis	0.0~30.0 (Hz)	0.0
<i>F270</i>	Jump frequency 1	0.0~ <i>FH</i> (Hz)	0.0
<i>F271</i>	Jump step 1	0.0~30.0 Hz	0.0
<i>F272</i>	Jump frequency 2	0.0~ <i>FH</i> (Hz)	0.0
<i>F273</i>	Jump step 2	0.0~30.0 Hz	0.0
<i>F274</i>	Jump frequency 3	0.0~ <i>FH</i> (Hz)	0.0
<i>F275</i>	Jump step 3	0.0~30.0 Hz	0.0
<i>F359</i>	PID control switching	0: No PID 1: Process PID control (temperature, pressure, etc.) 2: Speed PID control (potentials etc.) 3: Stop holding P control	0
<i>F360</i>	PID control feedback control signal selection	0: Deviation input (no feedback input) 1: VI/II (voltage/current input) 2: RR/S4 (potentiometer/voltage input) 3: RX (voltage input) 4: Option AI1 (differential current input) 5: Option AI2 (voltage/current input) 6: PG feedback option	0
<i>F361</i>	Delay filter	0.0~25.0	0.1
<i>F362</i>	Proportional (P) gain	0.01~100.0	0.10
<i>F363</i>	Integral (I) gain	0.01~100.0	0.10

<i>F364</i>	PID deviation upper limit	<i>LL~UL</i> (Hz)	<i>UL</i>
<i>F365</i>	PID deviation lower limit	<i>LL~UL</i> (Hz)	<i>UL</i>
<i>F366</i>	Differential (D) gain	0.00~2.55	0.00
<i>F367</i>	Process upper limit	<i>LL~UL</i> (Hz)	<i>UL</i>
<i>F368</i>	Process lower limit	<i>LL~UL</i> (Hz)	<i>LL</i>
<i>F369</i>	PID control waiting time	0~2400 (sec.)	0
<i>F370</i>	PID output upper limit	<i>LL~UL</i> (Hz)	<i>UL</i>
<i>F371</i>	PID output lower limit	<i>LL~UL</i> (Hz)	<i>LL</i>
<i>F372</i>	Process increasing rate (speed type PID control)	0.1~600.0	10.0
<i>F373</i>	Process decreasing rate (speed type PID control)	0.1~600.0	10.0
<i>F660</i>	Override addition input selection	0: Deselect 1: VI/II (voltage/current input) 2: RR/S4 (potentiometer/voltage input) 3: RX (voltage input) 4: Operation panel input enabled (including LED/LCD panel option input) 5: Operation panel RS485 (2-wire) communications input 6: Internal RS485 (4-wire) communication input 7: Communications option input 8: Option AI1 (differential current input) 9: Option AI2 (voltage/current input) 10: UP/DOWN frequency 11: RP pulse input 12: High-speed pulse input 13: Binary/BCD input	0
<i>F661</i>	Override multiplication input selection	0: Deselect 1: VI/II 2: RR/S4 3: RX 4: <i>F729</i> 5: AI1	0
<i>F702</i>	Frequency free unit display magnification	0.00: OFF, 0.01~200.0	0.00
<i>F703</i>	Frequency free unit conversion selection	0: All frequencies display free unit selection 1: PID frequencies free unit selection	0
<i>F729</i>	Operation panel override multiplication gain	-100~100 (%)	0

[Input/output terminal function]

	Positive logic	Negative logic	Function
Input terminal	36	37	PID control OFF selection
	52	53	PID differentiation/integration reset
	54	55	PID forward/reverse switching
Output terminal	38	39	PID deviation limit

[FM/AM pulse output and monitor output function]

FM/AM/pulse output		Monitor output		Function
Option No.	Communication No.	Option No.	Communication No.	
13	FD22	13	FE22	PID feedback value

- For PID control, the process value and the feedback value are converted into frequencies for reasons of processing.
However, the need to convert the process value and the feedback value into frequencies can be eliminated by the use of parameters *F 702* (free unit selection) and *F 703* (conversion item selection). (Refer to Section 2.1.13.)

1.2.2. Maximum frequency

- For the maximum frequency (*F H*), specify the highest frequency that the inverter can output.
For PID control, you are recommended to specify a frequency 10% or so higher than the upper limit frequency (*U L*). (Refer to Section 1.2.5.)

1.2.3. Upper limit frequency

- For the upper limit frequency (*U L*), specify the upper limit frequency of the motor used.

1.2.4. Specifying the feedback value

- To select an input device for feedback value control signals, use the PID control feedback control signal selection parameter (*F 360*).
- For analog input, refer to section 2.2.
- Set the zero point for the feedback value at 0Hz, and the maximum output for the feedback value at the maximum frequency.

For example, if the output ranges from 4 to 20mA, set an output of 20% at 0Hz and an output of 100% at the maximum frequency.

Example of V/I terminal setting

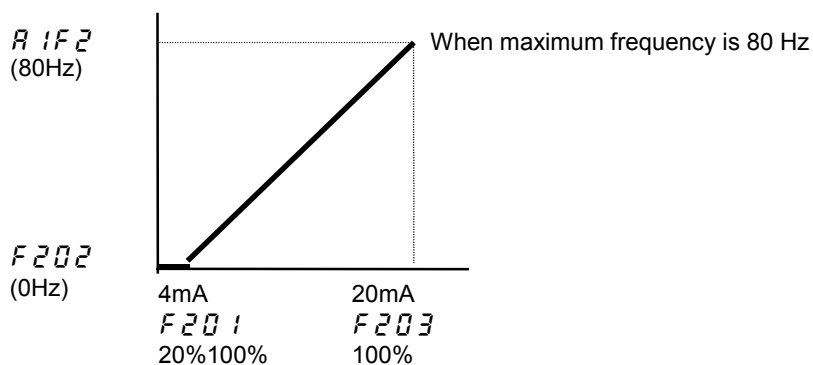

[Feedback value input setting]

Description	PID control feedback control signal selection (<i>F 3 5 0</i>)
Deviation input (no feedback input)	0
VI/II (voltage/current input)	1
RR/R4 (potentiometer/voltage input)	2
RX (voltage input)	3
AI1 (differential current input)	4
AI2 (voltage/current input)	5
PG feedback option	6

The characteristic can be reversed by changing parameter settings.
 Example of VI/II terminal setting

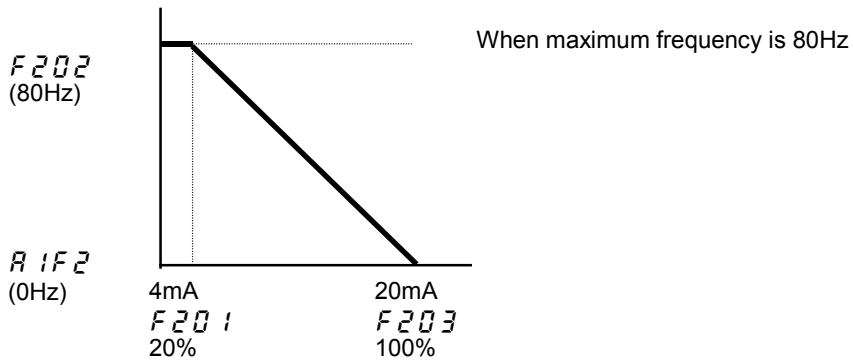

The characteristic of the feedback value can also be reversed by means of a signal from an external device.

Example: To use the S3 terminal as a PID normal/reverse characteristic switching signal input terminal

Title	Function	Adjustment range	Examples of settings
<i>F 1 1 7</i>	Input terminal function selection 7 (S3)	0~135	54 (positive logic) 55 (negative logic)

[When switching between the PID normal and reverse characteristic of the feedback value (maximum frequency: 80Hz) to the VI/II terminal, using the S3 terminal]

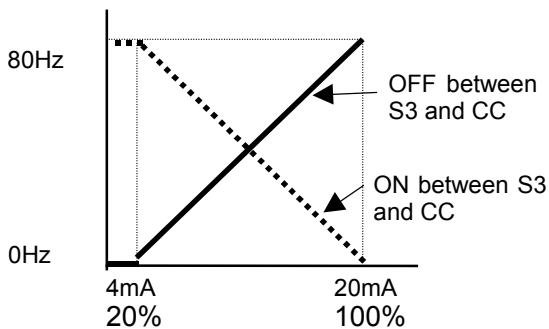

Title	Function	Default setting
<i>R 1 F 2</i>	VI/II input point 2 frequency	80
<i>F 1 1 7</i>	Input terminal function selection 7 (S3)	54
<i>F 2 0 1</i>	VI/II input point 1 setting	20
<i>F 2 0 2</i>	VI/II input point 1 frequency	0
<i>F 2 0 3</i>	VI/II input point 2 setting	100

1.2.5. Specifying the process value

- The process value is determined by the frequency command value set with a frequency setting mode selection parameter (*F_{10d}* or *F₂₀₇*). When specifying a frequency command value, set a target for the feedback value as the process value.
- For analog input, refer to section 2.2.
- The process value can also be specified with a preset speed operation frequency setting parameter.

[Process value input setting]

Description	Frequency setting mode selection 1 (<i>F_{10d}</i>)
	Frequency setting mode selection 2 (<i>F₂₀₇</i>)
VI/II (voltage/current input)	1
RR/S4 (potentiometer/voltage input)	2
RX (voltage input)	3
Operation panel input enabled (including LED/LCD panel option input)	4
Operation panel RS485 (2-wire) communication input	5
Internal RS485 (4-wire) communication input	6
Communications option input	7
Option AI1 (differential current input)	8
Option AI2 (voltage/current input)	9
UP/DOWN frequency	10
RP pulse input	11
High-speed pulse input	12
Binary/BCD input	13

An example of the setting of the process value

In the system shown in the figure below in which the feedback value (4 to 20mA (1 to 2 atm)) is input via the VI/II terminal, the process value is input via the RR/S4 terminal and the maximum frequency is set at 80Hz, the process value is set so that the feedback value will be 1.5 atm when the pressure is set at 1.5 atm.

In the example shown below, a process value of 5V corresponds to a pressure of 1.5 atm and to a frequency command value of 40Hz. (Note that the actual output frequency is not always 40Hz.)

Example of a system

Parameter setting : $FNOd = 2$ (RR/S4 input) $F360 = 1$ (VI/II input)
 $FH = 80.0$ $UL = 70.0$

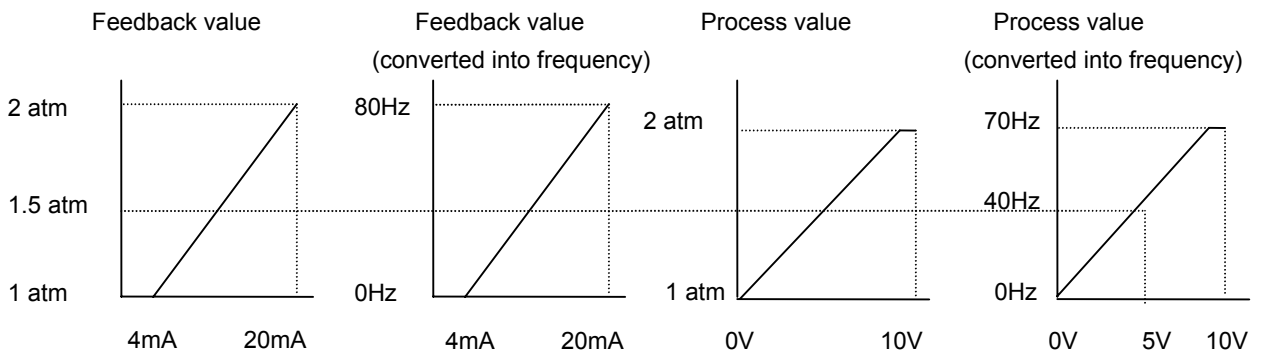
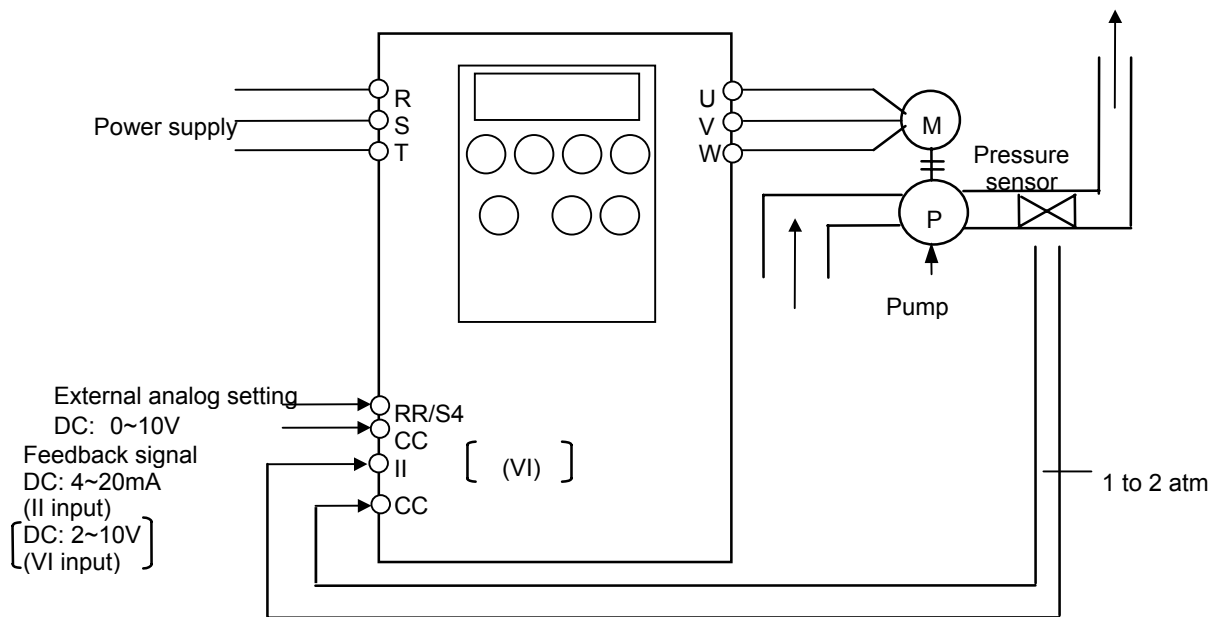

Feedback value (4~20mA)	Process value (0~10V)	Operation frequency command value (Hz)
4	0	0
8	2.5	20
12	5.0	40
16	7.5	60
20	10	80

* The actual motor operation frequency varies according to the PID control results and does not always agree with this frequency.

Note:

If the process value is 10V at 80Hz, the deviation will become zero when the feedback value is 20mA at 80Hz.

If the actual output frequency increases at that time, the feedback value will be limited to the maximum frequency and it will not exceed 80Hz at 20mA, and therefore the output frequency will be fixed at 80Hz.

In the example shown above, therefore, you can prevent the output frequency from being fixed at the maximum frequency by setting the upper limit frequency at 70Hz or so, as described in section 1.2.3, "Upper limit frequency."

Therefore, the process value or the frequency should be set lower than the maximum frequency.

1.2.6. Acceleration/deceleration time

- Set the acceleration/deceleration time (ACC/DEC) carefully so that it will not cause the inverter to trip.
The longer acceleration/deceleration time, the slower the speed of response of process PID control.
The smaller acceleration/deceleration time, the bigger the risk of tripping of the inverter.

1.2.7. Upper limit frequency, lower limit frequency and jump frequency

- The upper limit frequency (UL), the lower limit frequency (LL) and the jump frequencies set with parameters $F270$ to $F275$ are valid for output frequencies.

1.2.8. Override processing

- The override processing settings made with $F660$ and $F661$ are valid for the process value.
These parameters are used to fine adjust the process value.

1.2.9. Operation starting frequency

- The operation starting frequency set with $F240$ or $F241$ is valid for output frequencies.
Operation starts when the output frequency increases to the operation starting frequency ($F240+F241$) or above, and it stops when the output frequency decreases to the operation starting frequency ($F240-F241$) or below.

1.2.10. Switching to open loop operation

- To switch from PID operation (automatic operation) to open loop operation (manual operation), use the PID control OFF selection functions (input terminal functions: 36 and 37).
When switching to open loop operation, take care because the acceleration/deceleration time is very short at that time because of PID control.
(Use the acceleration/deceleration time 2 parameter or any other proper parameter, if necessary.)

1.2.11. Resetting the integral gain and differential gain set for PID control

- To reset the integral gain and differential gain set for PID control (automatic operation), use the PID differential gain and integral gain reset functions (input terminal functions: 52 and 53).

2. Adjusting PID control gains

- Adjust PID control gains according to the process value, the feedback input signal and the item to be controlled.

Here are the parameters used to adjust PID control gains.

Title	Function	Adjustment range	Default setting
<i>F 361</i>	Delay filter	0.0~25.0	0.1
<i>F 362</i>	Proportional (P) gain	0.01~100.0	0.10
<i>F 363</i>	Integral (I) gain	0.01~100.0	0.10
<i>F 364</i>	PID deviation upper limit	<i>LL</i> ~ <i>UL</i> (Hz)	<i>UL</i>
<i>F 365</i>	PID deviation lower limit	<i>LL</i> ~ <i>UL</i> (Hz)	<i>UL</i>
<i>F 366</i>	Differential (D) gain	0.00~2.55	0.00
<i>F 367</i>	Process upper limit	<i>LL</i> ~ <i>UL</i> (Hz)	<i>UL</i>
<i>F 368</i>	Process lower limit	<i>LL</i> ~ <i>UL</i> (Hz)	<i>LL</i>
<i>F 369</i>	PID control waiting time	0~2400 (sec.)	0
<i>F 370</i>	PID output upper limit	<i>LL</i> ~ <i>UL</i> (Hz)	<i>UL</i>
<i>F 371</i>	PID output lower limit	<i>LL</i> ~ <i>UL</i> (Hz)	<i>LL</i>
<i>F 372</i>	Process increasing rate (speed type PID control)	0.1~600.0	10.0
<i>F 373</i>	Process decreasing rate (speed type PID control)	0.1~600.0	10.0
<i>F 702</i>	Frequency free unit display magnification	0.00:OFF, 0.01~200.0	0.00
<i>F 703</i>	Frequency free unit conversion selection	0:All frequencies display free unit selection 1:PID frequencies free unit selection	0

2.1.1. Adjusting the proportional (P) gain

- The proportional (P) gain set with *F 362* is the proportional (P) gain obtained by PID control. A proportional (P) gain, a factor by which the deviation (difference between the process value and the feedback value) is multiplied, is used to perform control in such a way as to make a correction in proportion to the deviation. Although setting this gain high is effective in increasing the response speed, setting it excessively high may cause an unstable operation, such as vibration.

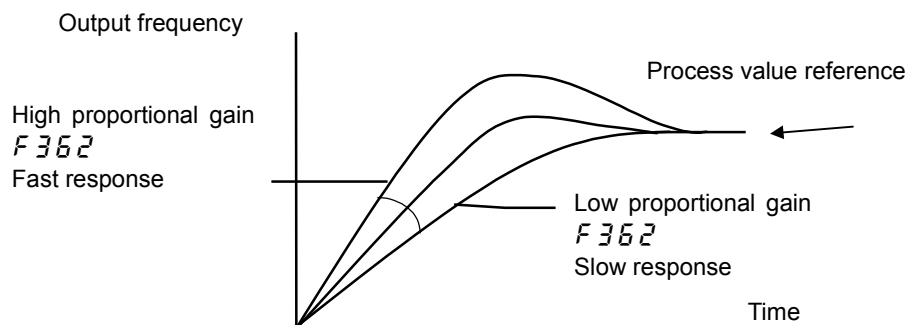

2.1.2. Adjusting the integral (I) gain

- The integral (I) gain set with $F\ 3\ 6\ 3$ is the integral (I) gain obtained by PID control. The integral gain reduces the deviation remaining after proportional control to zero (offsetting of residual deviation). Although setting this gain high is effective in reducing the residual deviation, setting it excessively high may cause an unstable operation, such as vibration.

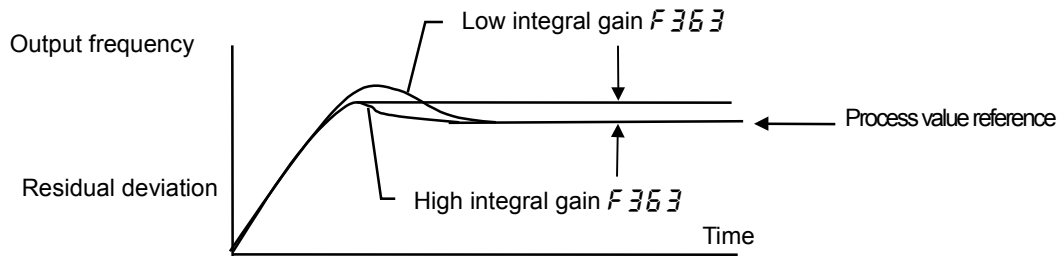

2.1.3. Adjusting the differential (D) gain

- The differential (D) gain set with $F\ 3\ 6\ 6$ is the differential (D) gain obtained by PID control. The differential gain increases the speed of response to rapid changes in deviation. If this gain is set excessively high, a phenomenon in which the output frequency greatly fluctuates may occur.

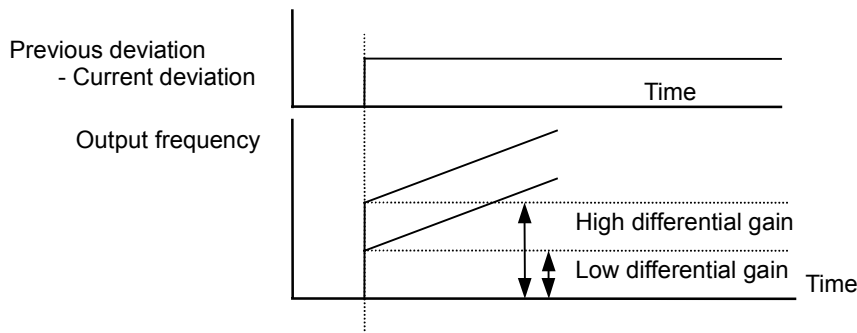

2.1.4. Adjusting the delay filter

- The delay filter set with $F\ 3\ 6\ 1$ moderates changes in deviation (primary delay control). Its setting does not need to be changed under normal conditions. Specify a small value to increase the processing speed or a large value to reduce it.

2.1.5. Adjusting the PID deviation upper limit

- The PID deviation upper limit set with $F\ 3\ 6\ 4$ is the upper limit to the increase (+) in deviation. It limits momentary deviations. It does not need to be changed under normal conditions.

2.1.6. Adjusting the PID deviation lower limit

- The PID deviation lower limit set with *F 365* is the lower limit to the decrease (-) in deviation. It limits momentary deviations. It does not need to be changed under normal conditions.

2.1.7. Adjusting the target upper limit

- The target upper limit set with *F 367* is the upper limit to the process value. It limits the process value. It is set at the same frequency as the upper limit frequency (*UL*) and it does not need to be changed under normal conditions.

2.1.8. Adjusting the target lower limit

- The target lower limit set with *F 368* is the lower limit to the process value. It limits the process value. It is set at the same frequency as the lower limit frequency (*LL*) and it does not need to be changed under normal conditions.

2.1.9. Adjusting the PID start waiting time

- If you do not want your inverter to start PID control before the control system becomes stable, for example, immediately after startup, you can specify a waiting time during which the inverter does not start PID control.
- During the PID control waiting time set with *F 369*, the inverter carries out operation at the frequency determined by the process value, ignoring feedback input signals, and on expiration of the specified waiting time, it goes into PID control mode.

2.1.10. Adjusting the PID output upper limit

- The PID output upper limit set with *F 370* is the upper limit to frequencies output by PID control. It is set at the same frequency as the upper limit frequency (*UL*) and it does not need to be changed under normal conditions.

2.1.11. Adjusting the PID output lower limit

- The PID output lower limit set with *F 371* is the lower limit to frequencies output by PID control. It is set at the same frequency as the lower limit frequency (*LL*) and it does not need to be changed under normal conditions.

2.1.12. Adjusting the increase and decrease rates of the target value

- The target value increase and decrease rates set with $F\ 3\ 72$ and $F\ 3\ 73$, respectively, determine the feedback value or the response during speed PID control.
- To increase the speed of response, specify low rates.

2.1.13. Converting the units of the process value and feedback value

- For PID control, the process value and the feedback value need to be converted into frequencies for reasons of processing, but the need to convert them into frequencies can be eliminated by the use of parameters $F\ 702$ (free unit selection) and $F\ 703$ (conversion item selection).

If $F\ 703$ is set to 1, the values obtained by multiplying the frequencies displayed on the monitor or specified with the following parameters by the value specified with $F\ 702$ are displayed.

$$\boxed{\text{[Value displayed]}} = \boxed{\text{[Frequency displayed on the monitor or specified with a parameter]}} \times \boxed{\text{[value specified with } F\ 702\text{]}}$$

[Parameters]

Title	Function
$F\ 364$	PID deviation upper limit
$F\ 365$	PID deviation lower limit
$F\ 367$	Process upper limit
$F\ 368$	Process lower limit

[FM/AM pulse output and monitor display]

FM/AM pulse output		Monitor output		Function
Option No.	Communication No.	Option No.	Communication No.	
1	FD02	1	FE02	Operation frequency command value
13	FD22	13	FE22	PID feedback value

2.2. Adjusting the analog command voltage

For items which can be adjusted by feedback input, such as voltage/current input (VI/II input), potentiometer/voltage input (RR/S4 input) and voltage input (RX input), adjust the voltage scaling factor if necessary.

For example, when feedback signals are very weak, the gain can be increased by this adjustment.

Example of setting when VI/II is used as a voltage input terminal (factory default setting)

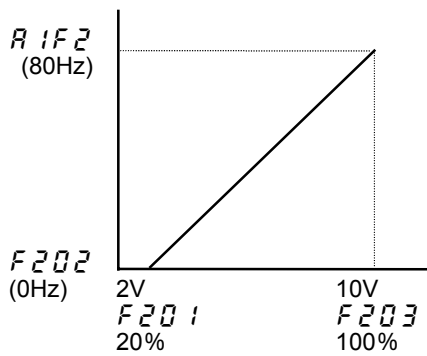

Example of setting when VI/II is used as a current input terminal

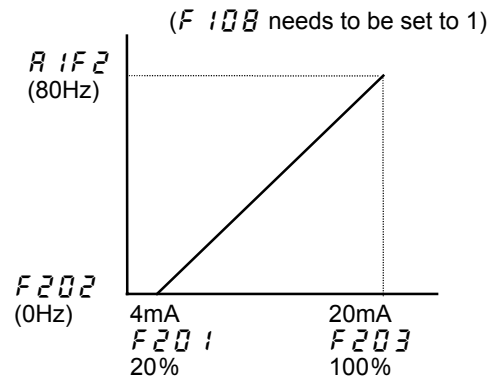

Example of RR/S4 terminal setting (default setting)

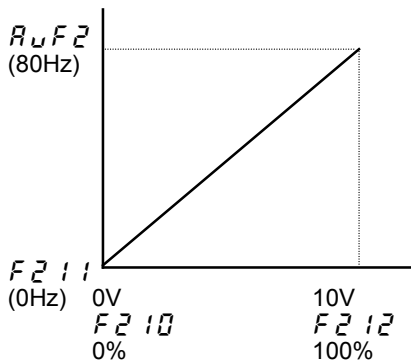

Example of RX terminal setting (default setting)

