



SF-G Series  
5.5-160KW

High Quality

Innovation

Quality  
and  
Innovation

Industrial  
Upgrading

High Tech

WWW.SEEC.COM.TW

# High-performance Vector-type SF-G Series Inverter

## Superior Performance just for your



## Preface

*Thank you for your continuous use and support of our company's products. Our company's R&D group's long-term technical collaboration with domestic research institutes and the world's major companies enables us to steadily work on the research and development of various products. Indeed, Shihlin Electric's FA related products have reached international standard.*

*With years of effort in promoting inverters and accommodating customer requirements, as well as detailed planning and design, now we are launching the SF020/040 series inverter. Whether it is product R&D stage, final product verification, or product manufacturing, all the processes are conducted under tight and systemic control. The quality of Shihlin Electric products wins customer trust, and thus Shihlin Electric products are your best choice.*

*Please contact us if you have any special need. For tasks entrusted by our customers, we will design inverters specifically meeting the customers' needs in a short period of time with excellent professional background and rigorous attitude.*

*To fully deliver the superior performance of the products as well as for the safety considerations for people and equipments, please read this manual carefully and keep it for later calibration or maintenance.*

## TABLE OF CONTENTS

1. Manual Guide .....	1
2. Delivery Check .....	3
2.1 Nameplate Instruction .....	3
2.2 Type Instruction.....	3
2.3 Order Code Description .....	3
3. Shihlin Inverter Introduction.....	4
3.1 Electric Specification .....	4
3.2 General Specification (Inverter Characteristics).....	7
3.3 Appearance and Dimensions .....	9
3.4 Name of Each Component.....	12
3.5 Installation and Wiring.....	16
3.6 Mini Jumper Instruction.....	27
3.7 Selection of Peripheral Equipment.....	28
4. Primary Operation.....	35
4.1 Operating Modes of the Inverter.....	35
4.2 Basic Operation Procedures for Different Modes .....	41
4.3 Operation .....	45
5. Parameter Description.....	47
5.1 Torque Boost (P.0, P.46) .....	47
5.2 The Range of the Output Frequency (P.1, P.2 and P.18) .....	48
5.3 Base Frequency and Base Frequency Voltage (P.3, P.19 and P.47) .....	48
5.4 Multi-speed (P.4~P.6, P.24~P.27 and P.142~P.149).....	49
5.5 Acceleration / Deceleration Time (P.7, P.8, P.20, P.21,P.44 and P.45).....	51
5.6 Electronic Thermal Relay Capacity (P.9).....	52
5.7 DC Injection Brake (P.10, P.11 and P.12) .....	53
5.8 Starting Frequency (P.13).....	54
5.9 Load Pattern Selection (P.14, P.98~P.99, P.162~P.169) .....	54
5.10 JOG Mode (P.15 and P.16) .....	57
5.11 Stall Prevention (P.22, P.23 and P.66) .....	57
5.12 Output Frequency Filter Constant (P.28) .....	59
5.13 Acceleration / Deceleration Pattern Selection (P.29).....	59
5.14 Regenerative Brake (P.30 and P.70) .....	61
5.15 Soft-PWM (P.31) .....	61
5.16 Communication Function (P.32, P.33, P.36, P.48~P.53, P.153 and P.154).....	62
5.17 Speed Display (P.37).....	79
5.18 Voltage Signal Selection and Target Frequency (P.38, P.73, P.139, P.140 and P.141) .....	80
5.19 The Input Signal across Terminal 4-5 and the Target Frequency (P.39) .....	84
5.20 Multi-function Output (P.40, P.85, P.129, P.130, P.120) .....	84

5.21 Up-to-frequency Sensitivity (P.41).....	86
5.22 Output Frequency Detection (P.42 and P.43).....	87
5.23 FM/AM Terminal (P.54~P.56, P.64, P.187, P.190 and P.191).....	88
5.24 Restart Function (P.57, P.58, P.150 and P.160).....	90
5.25 Input Signal Filter Constant (P.60).....	91
5.26 Remote Setting Function (P.61).....	91
5.27 Zero Current Detection (P.62 and P.63).....	94
5.28 Retry Function (P.65, P.67, P.68, P.69).....	94
5.29 Brake Selection (P.71).....	96
5.30 Carrier Frequency (P.72).....	96
5.31 FR/10X Frequency Output Terminal Selection (P.74).....	97
5.32 Stop or Reset Function Selection (P.75).....	98
5.33 Parameters Write Protection (P.77).....	98
5.34 Forward/Reverse Rotation Prevention Selection (P.78).....	99
5.35 Operation Mode Selection (P.79).....	99
5.36 Multi-function Terminal Function Selection (P.80~P.84, P.86, P.126~P.128).....	100
5.37 Slip Compensation Coefficient (P.89).....	105
5.38 Frequency Jump (P.91~P.96).....	105
5.39 Programmed Operation Mode (P.100~P.108, P.111~P.118, P.121~P.123, P.131~P.138).....	106
5.40 Operation Panel Monitoring Selection (P.110).....	108
5.41 Zero-Speed Function (P.151~P.152).....	109
5.42 OverTorque Detection (P.155~P.156).....	109
5.43 External Terminals Filter Adjusting Function (P.157).....	110
5.44 External Terminal Power Enable Function(P.158).....	111
5.45 Energy-Saving Control Function (P.159).....	111
5.46 Multi-Function Display (P.161).....	112
5.47 PID Control (P.170~P.183).....	113
5.48 4-5 Terminal Disconnection Handling Function (P.184).....	116
5.49 SF-G Model Selection Function (P.186).....	117
5.50 Firmware version (P.188).....	117
5.51 Factory Setting Function (P.189).....	117
5.52 2-5 Terminal Input Signal (P.192~P.195).....	118
5.53 4-5 Terminal Input Signal (P.196~P.199).....	119
5.54 Multi-machine Constant Pressure System Function (P.200, P.209, P.210, P.213~P.217, P.223~P.225) .....	121
5.55 Backlash Compensation Function (P.229~P.233).....	124
5.56 Triangular Wave Function (P.234~P.239).....	125
5.57 Auxiliary Frequency Function (P.240).....	126
5.58 DC Brake Function before Starting (P.242~P.244).....	126
5.59 Options for Stopping the Cooling Fan (P.245).....	127
5.60 Modulation Coefficient (P.246).....	128
5.61 Commercial Power Supply Frequency Operation Function (P.247~P.250).....	128
5.62 Injection Molding Machine Specific Functions (P.251~P.254).....	131
5.63 Vibration Inhibition Factor (P.285 and P.286).....	132

5.64 Short Circuit Protection Function (P.287).....	133
5.65 Alarm History Parameters (P.288~P.291) .....	133
5.66 Accumulative Motor Operation Time Function (P.292 and P.293).....	134
5.67 Password Protection Function (P.294 and P.295) .....	135
5.68 Motor Control Mode (P.300 and P.301) .....	135
5.69 Motor Parameter (P.302~P.312).....	137
5.70 Gain Adjustment at Speed Control (P.320~P.321).....	138
5.71 Feedback Control Parameters (P.350~P.354).....	139
5.72 Parameter Copy Function (P.994 and P.995) (a PU series operation panel needs to be purchased) ..	140
5.73 Alarm History Clear (P.996).....	141
5.74 Inverter Reset (P.997).....	141
5.75 Restoration of the Parameters to the Default Values (P.998 and P.999).....	141
6. Inspection and Maintenance .....	143
6.1 Daily Inspection.....	143
6.2 Periodical Inspection (During Machine Shutdown) Items .....	143
6.3 Regular Replacement for Some Components.....	144
6.4 Inverter Insulation Resistance Measurement.....	144
6.5 Motor Insulation Resistance Measurement .....	144
6.6 IGBT Module Test.....	145
Appendix 1 Parameter Table .....	146
Appendix 2 Alarm Code List.....	160
Appendix 3 Troubles and Solutions .....	164
Appendix 4 Optional Equipment.....	165
Appendix 5 European Specification Compatibility Description .....	170
Appendix 6 Australia C-Tick Specifications .....	173
Revision Record .....	174

## 1. Manual Guide

The Shihlin Electric SF Series inverters have been designed with many complex parameterized functions to meet most of the application requirements in the market. For first-time users, they may experience some problems while using an inverter of such complex nature. Therefore, we recommend each user to read through each part of this manual carefully in order to master the operating methods of the inverters. Please feel free to contact us if you have any question.

Chapter 3 of this manual lists the detailed specifications of Shihlin Electric SF Series inverters. Section 3.5 will guide you on how to install the inverters, with an emphasis on safety precautions that must be noted when using the inverters.

Chapter 4 guides customers on how to use the inverter. In Section 4.1, it gives a brief outline on the operating mode of the inverter and how to use the operation panel. In section 4.2, the simple operating steps are explained. Chapter 5 explains the function of each parameter in detail.

The definitions of terminologies used in this manual are as follow:

1. Output frequency, target frequency, steady output frequency

The actual output current frequency of the inverter is called “output frequency.”

The frequency set by user (through operation panel, multi-speed terminals, voltage signal, and current signal or communication settings) is called “target frequency.”

When the motor starts running, the output frequency of the inverter will gradually accelerate to the target frequency before it finally runs steadily at the target frequency. This output frequency is called “stead output frequency.”

2. Detail explanation on parameter settings are provided in Chapter 5. For users who are not familiar with these settings, arbitrary adjustment of the parameter may result in abnormal operations. All parameters can be reset to their default values by the parameter of P.998. For setting procedures of this parameter, please refer to P.998 in Chapter 5.

3. The “operation mode” and “working mode” of the operation panel

The operating mode determines the reference source for the target frequency and the signal source for starting. A total of nine operating modes are provided in each Shihlin inverter. Please refer to Section 4.1 for details.

The operation panel is used mainly for monitoring the numeric values, setting parameters and target frequency. There are a total of five working modes on the Shihlin operation panel. Please refer to Section 4.1 for details.

4. The difference between “terminal name” and “function name”:

Printed letters can be found near the terminals of either the control board or the main board. They are used to distinguish each terminal and are called “terminal name.”

For “multi-function control terminal” and “multi-function output terminal,” besides the terminal name, it is also necessary to define the “function name.” The function name indicates the actual functions of the terminal.

When explaining the function for a terminal, the name used is its “function name.”

5. The difference between “on” and “turn on”:

When explaining the function for the “multi-function control terminal”, two words “on” and “turn on” are often used:

The word “on” is used to indicate that the external switch of the terminal is in close state, and thus it belongs to the description of the state.

The word “turn on” is used to describe the action that the external switch of the terminal is shut from the open state to the close state, and thus belongs to the description of action. Similarly, the words “off” and “turn off” belong to the above-mentioned states and actions.

## 2. Delivery Check

Each SF-TYPE inverter has been checked thoroughly before delivery, and is carefully packed to prevent any mechanical damage. Please check for the following when opening the package.

Checking out whether the product was damaged during transportation.

Whether the model of inverter coincide with what is shown on the package.

### 2.1 Nameplate Instruction

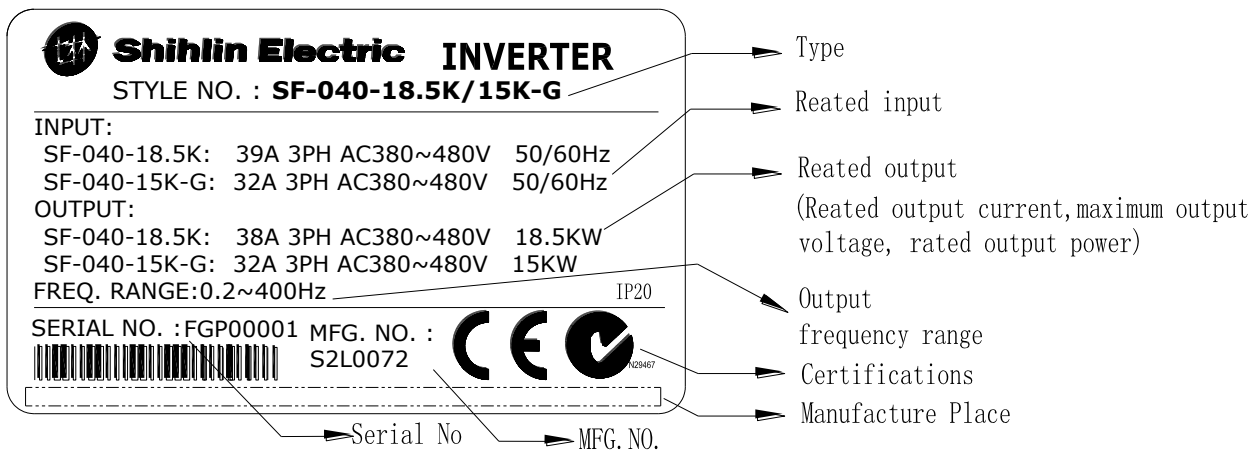

### 2.2 Type Instruction

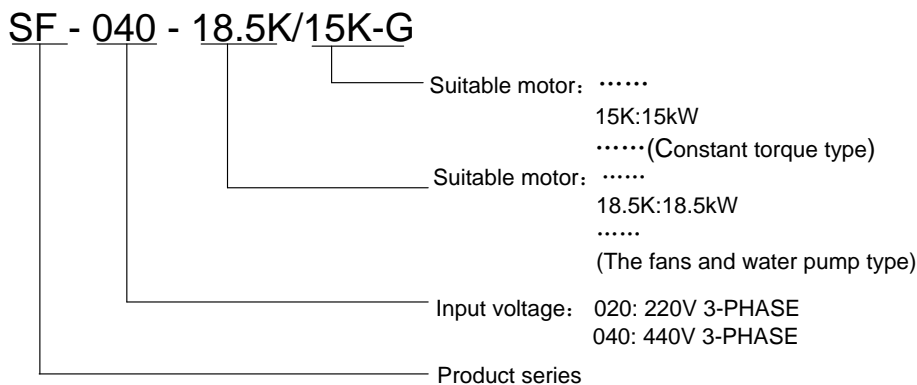

### 2.3 Order Code Description

Example:

Customer requirement	Order code
Inverter specification	
SF-040-7.5K/5.5K-G(SF Series 440V 7.5K(F)/5.5K(G) Inverter)	SNKSF407R5F5R5G
SF-020-18.5K/15K-G(SF Series 220V 18.5K(F)/15(G) Inverter)	SNKSF2018R5F15G
SF-040-55K/45K-G(SF Series 440V 55K(F)/45K(G) Inverter)	SNKSF4055F45G

## 3. Shihlin Inverter Introduction

### 3.1 Electric Specification

#### 3.1.1 220V Series Three-phase

Model SF-020-□□□K/K-G		5.5	7.5/5.5	11/7.5	15/11	18.5/15
Applicable motor capacity	HP	7.5	10/7.5	15/10	20/15	25/20
	kW	5.5	7.5/5.5	11/7.5	15/11	18.5/15
Output	Rated output capacity kVA	9.5	12.5/9.5	18.3/12.5	24.7/18.3	28.6/24.7
	Rated output current A	25	33/25	49/33	65/49	75/65
	Overload current rating	120% 60 seconds / 150% 60 seconds (inverse time characteristics)				
	Maximum output voltage	Three-phase 200 ~ 240V				
Power supply	Rated power voltage	Three-phase 200 ~ 240V 50Hz / 60Hz				
	Power voltage permissible fluctuation	Three-phase 180~ 264V 50Hz / 60Hz				
	Power frequency permissible fluctuation	±5%				
	Power source capacity kVA	12	17/12	20/17	28/20	34/28
Cooling method		Forced air cooling				
Inverter weight kg		5.6	5.6	7.0	8.3	9.0

Model SF-020-□□□K/K-G		22/18.5	30/22	37/30	45/37	55/45
Applicable motor capacity	HP	30/25	40/30	50/40	60/50	75/60
	kW	22/18.5	30/22	37/30	45/37	55/45
Output	Rated output capacity kVA	34.3/28.6	45.7/34.3	55/45.7	65/55	81/65
	Rated output current A	90/75	120/90	145/120	170/145	212/170
	Overload current rating	120% 60 seconds / 150% 60 seconds (inverse time characteristics)				
	Maximum output voltage	Three-phase 200 ~ 240V				
Power supply	Rated power voltage	Three-phase 200 ~ 240V 50Hz / 60Hz				
	Power voltage permissible fluctuation	Three-phase 180 ~ 264V 50Hz / 60Hz				
	Power frequency permissible fluctuation	±5%				
	Power source capacity kVA	41/34	52/41	65/52	79/65	99/79
Cooling method		Forced air cooling				
Inverter weight kg		20	21	37	37	67

# Shihlin Inverter Introduction

## 3.1.2 440V Series Three-phase



Model SF-040-□□□K/K-G		5.5	7.5/5.5	11/7.5	15/11	18.5/15	22/18.5	30/22	37/30
Applicable motor capacity	HP	7.5	10/7.5	15/10	20/15	25/20	30/25	40/30	50/40
	kW	5.5	7.5/5.5	11/7.5	15/11	18.5/15	22/18.5	30/22	37/30
Output	Rated output capacity kVA	10	14/10	18/14	25/18	29/25	34/29	46/34	56/46
	Rated output current A	13	18/13	24/18	32/24	38/32	45/38	60/45	73/60
	Overload current rating	120% 60 seconds / 150% 60 seconds (inverse time characteristics)							
	Maximum output voltage	Three-phase 380 ~ 480 V							
Power supply	Rated power voltage	Three-phase 380 ~ 480V 50Hz / 60Hz							
	Power voltage permissible fluctuation	Three-phase 342 ~ 528V 50Hz / 60Hz							
	Power frequency permissible fluctuation	±5%							
	Power source capacity kVA	11.5	16/11.5	20/16	27/20	32/27	41/32	52/41	65/52
Cooling method		Forced air cooling							
Inverter weight kg		5.6	5.6	5.6	5.6	8.3	8.3	25	25

Model SF-040-□□□K/K-G		45/37	55/45	75/55	90/75	110/90	132/110	160/132
Applicable motor capacity	HP	60/50	75/60	100/75	120/100	150/120	175/150	215/175
	kW	45/37	55/45	75/55	90/75	110/90	132/110	160/132
Output	Rated output capacity kVA	69/56	84/69	114/84	137/114	168/137	198/168	236/198
	Rated output current A	91/73	110/91	150/110	180/150	220/180	260/220	310/260
	Overload current rating	120% 60 seconds / 150% 60 seconds (inverse time characteristics)						
	Maximum output voltage	Three-phase 380 ~ 480 V						
Power supply	Rated power voltage	Three-phase 380 ~ 480V 50Hz / 60Hz						
	Power voltage permissible fluctuation	Three-phase 342 ~ 528V 50Hz / 60Hz						
	Power frequency permissible fluctuation	±5%						
	Power source capacity kVA	79/65	100/79	110/100	137/110	165/137	198/165	247/198
Cooling method		Forced air cooling						
Inverter weight kg		25	37	37	37	67	67	67

Note: The test conditions of rated output current, rated output capacity and frequency converter inverter power consumption are: the carrier frequency (P.72) is at the set value; the frequency converter/inverter output voltage is at 220V/440V; the output frequency is at 60Hz, and the ambient temperature is 40°C.

## 3.2 General Specification (Inverter Characteristics)

Control method	SVPWM control, V/F control, close-loop V/F control (VF+PG), general flux vector control, <b>sensorless vector control</b> (SVC), close-loop vector control (FOC+PG)	
Output frequency range	0.2~400Hz (The starting frequency setting range is 0~60Hz).	
Voltage / frequency output characteristics	Digital setting	If the frequency set value is below 100Hz, the resolution will be 0.01Hz; If the frequency set value is above 100Hz, the resolution will be 0.1Hz.
	Analog setting	When setting DC 0~5V signals, the resolution will be 1/500; When setting DC 0~10V or 4~20mA signals, the resolution will be 1/1000;
Output frequency accuracy	Digital setting	Maximum target frequency $\pm 0.01\%$ .
	Analog setting	Maximum target frequency $\pm 0.5\%$ .
Voltage / frequency output characteristics	<b>Base frequency voltage</b> (P.19), base frequency (P.3) can be arbitrarily set. Constant torque model and <b>applicable load model</b> can be selected (P.14).	
Start torque	150% 1Hz: When the sensorless vector control is started.	
Torque boost	The torque boost setting range is 0~30% (P.0), auto boost, slip compensation.	
Acceleration / deceleration curve characteristics	The resolution (0.01s/0.1s) of acceleration/deceleration time (P.7, P.8) is switched by P.21. The setting range has 0~360s or 0~3600s for selection. And different acceleration/deceleration curve model can be selected by P.29.	
DC braking	The DC braking action frequency is 0~120Hz (P.10); the DC braking time is 0~60s (P.11). The DC braking voltage is 0~30% (P.12). Linear braking and idling braking selection (P.71).	
Stalling protection	The stalling protection level can be set to 0~400% (P.22).	
Target frequency setting	Operation panel setting; DC 0~5V signal, DC 0~10V signal, DC 4~20 mA signal; multiple speed stage level setting; communication setting.	
PID control	Please refer to P.170~P.183 in Chapter 5.	
Multi-function control terminals	Motor starting (STF, STR), the second function (RT), 16-speed operation (RH, RM, RL, REX), external thermal relay (OH), reset (RES), etc. (they can be set by the user with P.80~P.84, P.86 and P.126~P.128) .	

Output terminal	Multi-function output terminals	SU,SE	<a href="#">P.40</a>	Inverter running (RUN), output frequency detection (FU), Up to frequency (SU), overload <b>alarm</b> (OL), zero current detection (OMD), alarm (ALARM), section detection (PO1), periodical detection (PO2), and pause detection (PO3), inverter output (BP), work frequency output (GP).
		RUN,SE	<a href="#">P.129</a>	
		FU/10X,SE	<a href="#">P.130</a>	
	Multi-function output relay	A,B,C	<a href="#">P.85</a>	
	Analog output	AM,5	Multi-function DC (0~10V) output: output frequency, current ( <a href="#">P.54</a> ).	
	Pulse output	FM,SD	Output the pulse of 0~2300Hz.	
Operation panel	Operation monitoring	Output frequency monitoring, output current monitoring, and output voltage monitoring, abnormality record (Maximum 12 sets).		
	LED indication lamp (8)	Forward rotation indication lamp, reverse rotation indication lamp, frequency monitoring indication lamp, voltage monitoring indication lamp, current monitoring indication lamp, mode switching indication lamp, PU terminals control indication lamp, and external terminals control indication lamp.		
Communication function		RS-485 communication, can select Shihlin/Modbus communication protocol.		
Protection mechanism / alarm function		Output short circuit protection, Over-current protection, (+/P)-(-/N) over-voltage protection, under-voltage protection, motor over-heat protection ( <a href="#">P.9</a> ), IGBT module over-heat protection, communication abnormality protection, etc.		
Environment	Ambient temperature	-10 ~ +40°C (non-freezing).		
	Ambient humidity	Below 90%Rh (non-condensing).		
	Storage temperature	-20 ~ +65°C。		
	Surrounding environment	Indoor, no corrosive gas, no flammable gas, no flammable powder.		
	Altitude and vibration	Altitude below 1000 meters, Vibration below 5.9m/s <sup>2</sup> (0.6G).		
	Grade of protection	IP20		
	The degree of environmental pollution	2		
	Class of protection	Class I		
International certification		 		

## 3.3 Appearance and Dimensions

### 3.3.1 Frame A/B

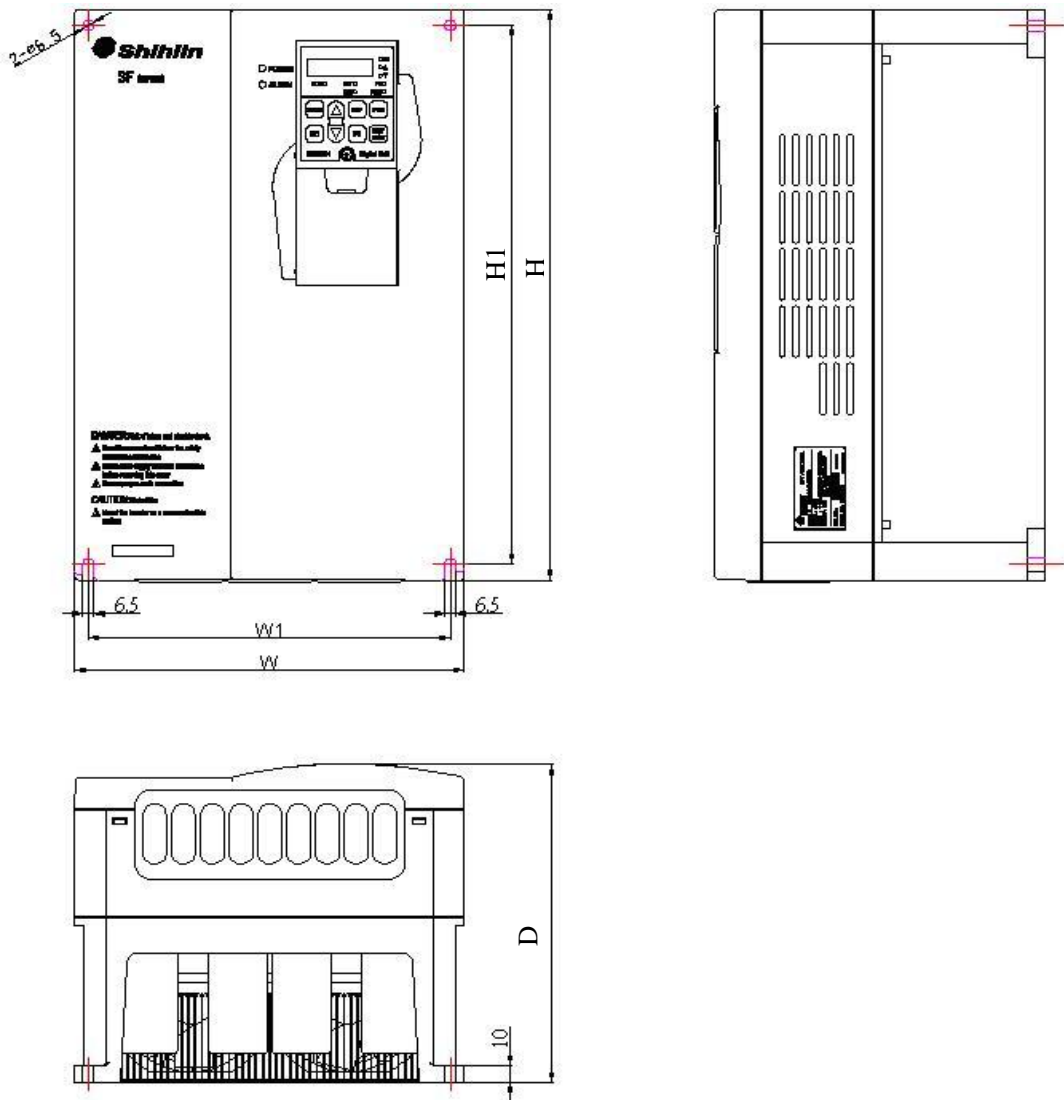

Model	Frame	H (mm)	H1 (mm)	W (mm)	W1 (mm)	D (mm)
SF-040-5.5K	A	323	303	200	186	186
SF-040-7.5K/5.5K-G						
SF-020-5.5K						
SF-020-7.5K/5.5K-G						
SF-040-11K/7.5K-G						
SF-040-15K/11K-G						
SF-020-11K/7.5K-G	B	350	330	230	214	195
SF-020-15K/11K-G						
SF-020-18.5K/15K-G						
SF-040-18.5K/15K-G						
SF-040-22K/18.5K-G						

## 3.3.2 Frame C

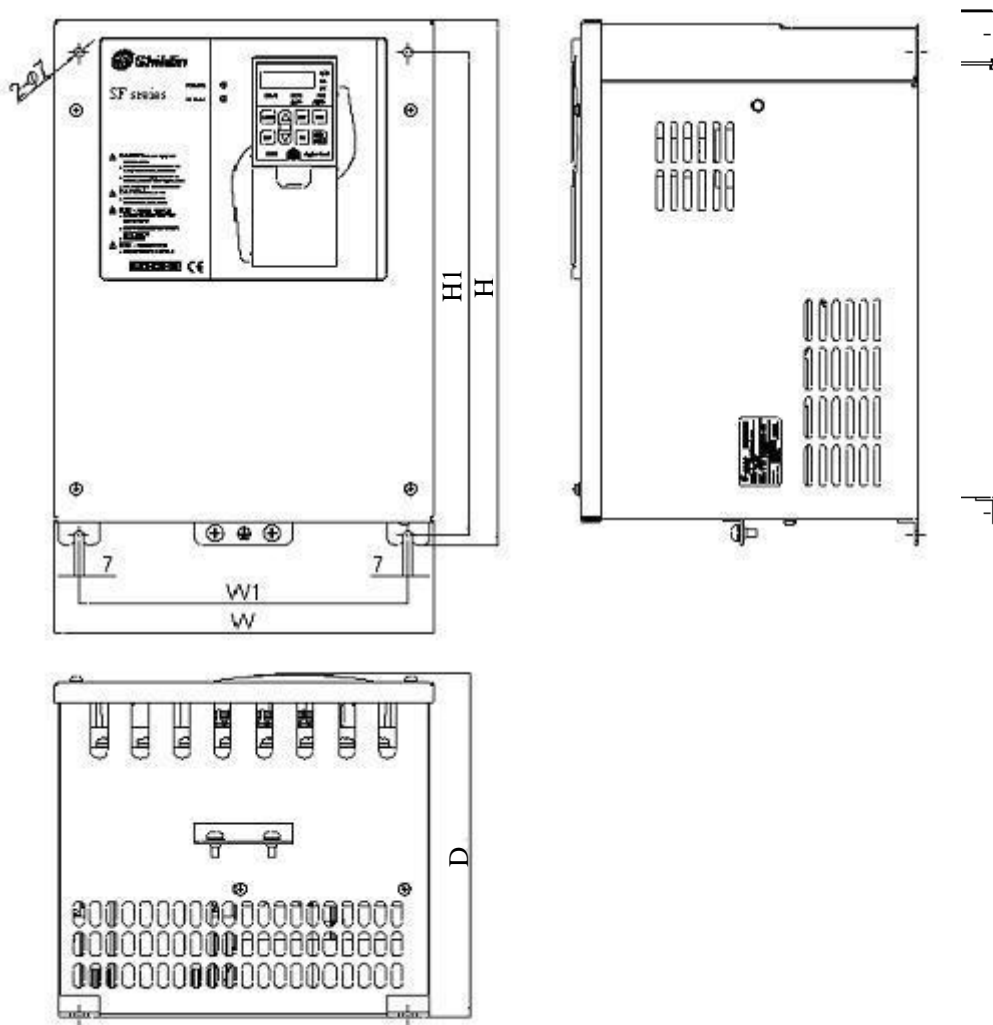

Inverter model	Frame	H (mm)	H1 (mm)	W (mm)	W1 (mm)	D (mm)
SF-020-22K/18.5K-G	C	379	348	271	236	248
SF-020-30K/22K-G						

## 3.3.3 Frame D/E/F

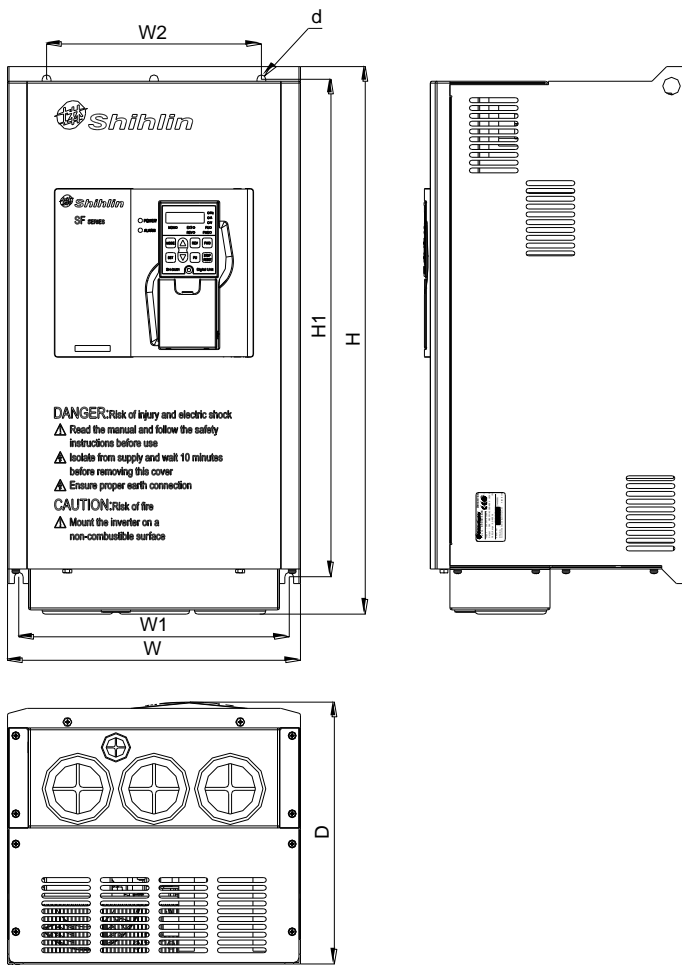

Model	Frame	H (mm)	H1 (mm)	W (mm)	W1 (mm)	W2 (mm)	D (mm)	d (mm)
SF-040-30K/22K-G	D	561	510	300	277	220	270	9
SF-040-37K/30K-G								
SF-040-45K/37K-G								
SF-040-55K/45K-G	E	595	566	370	336	336	286	13
SF-020-37K/30K-G								
SF-040-75K/55K-G								
SF-040-90K/75K-G								
SF-020-45K/37K-G	F	850	821	425	381	381	286	13
SF-020-55K/45K-G								
SF-040-110K/90K-G								
SF-040-132K/110K-G								
SF-040-160K/132K-G								

## 3.4 Name of Each Component

### 3.4.1 Nameplate and Model

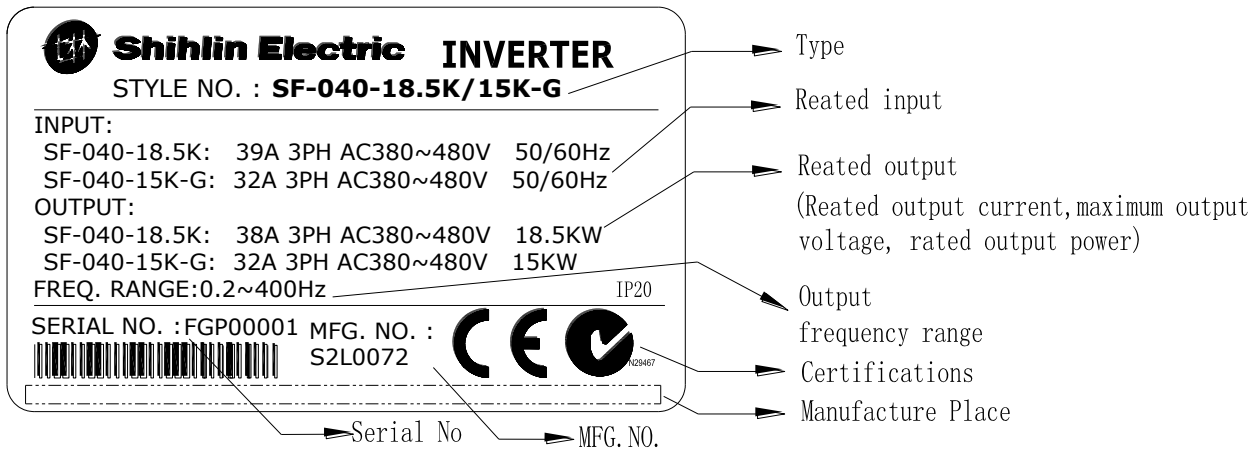

### 3.4.2 Names of the Components of Frame A/B

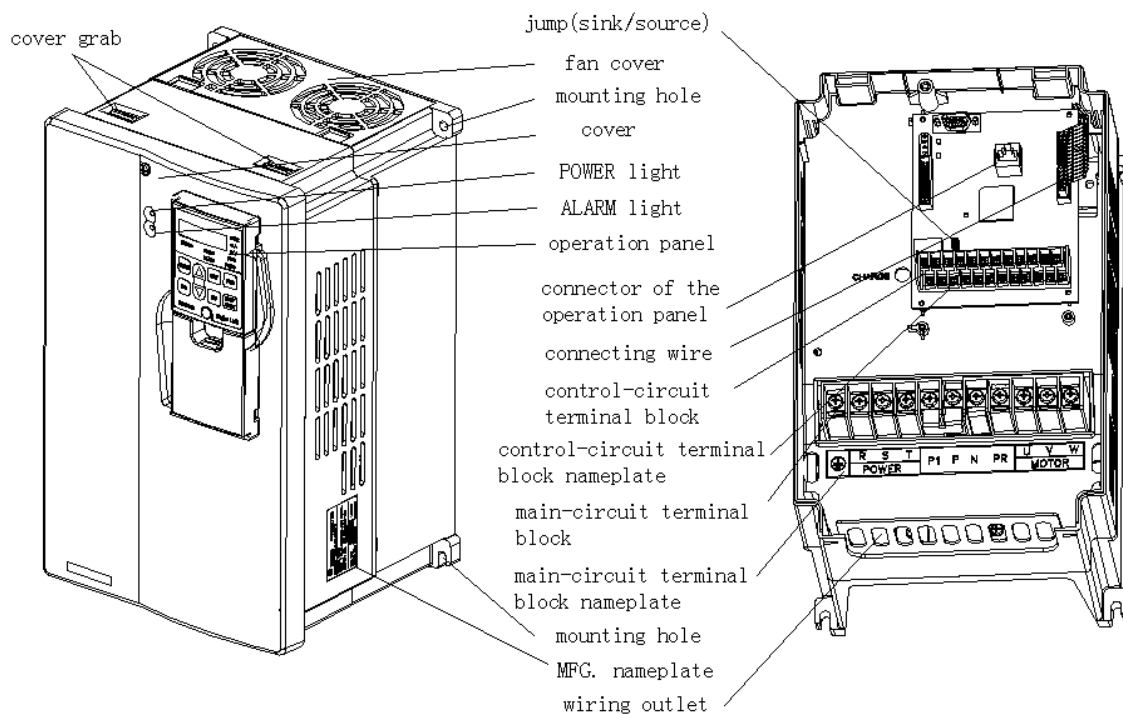

1. The above figure corresponds to all the models of frame A and B.
2. Push down the latch on the top cover and pull the latch toward the front of the inverter to remove the top cover.
3. "Wiring Outlet" is designed for fixing and protecting the lead wire. When wiring, the lead wire must pass through the "wiring outlet" and then connected to the terminals. Use cable ties to fix the wires in a bundle.

## 3.4.3 Names of the Components of Frame C

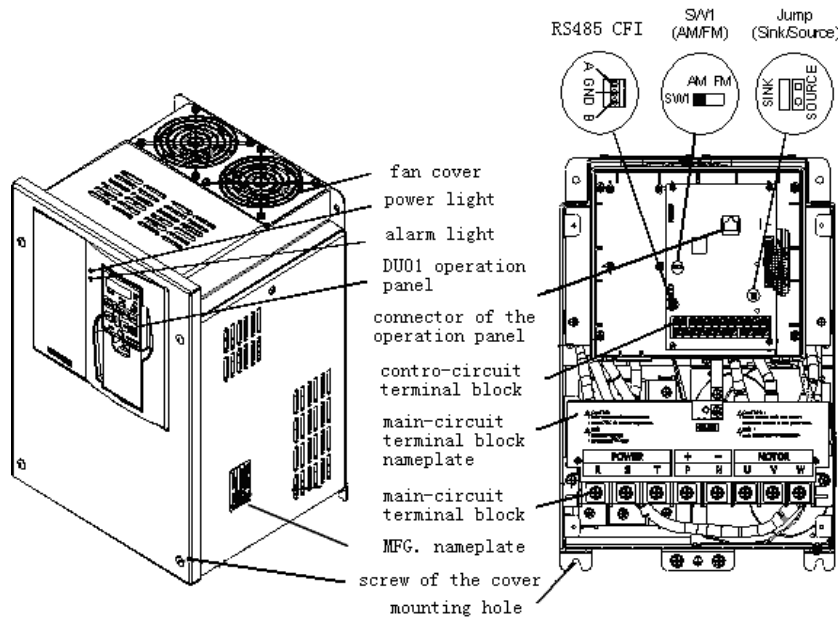

1. The above figure corresponds to all the models of frame C.
2. Loosen up the screws on the top cover and the top cover can be removed.
3. “Wiring Outlet” is designed for fixing and protecting the lead wire. When wiring, lead wire must pass through the “Wiring Outlet” and then connected with the terminals. Use cable ties to fix the wires in a bundle.

## 3.4.4 Names of the Components of Frame D/E/F

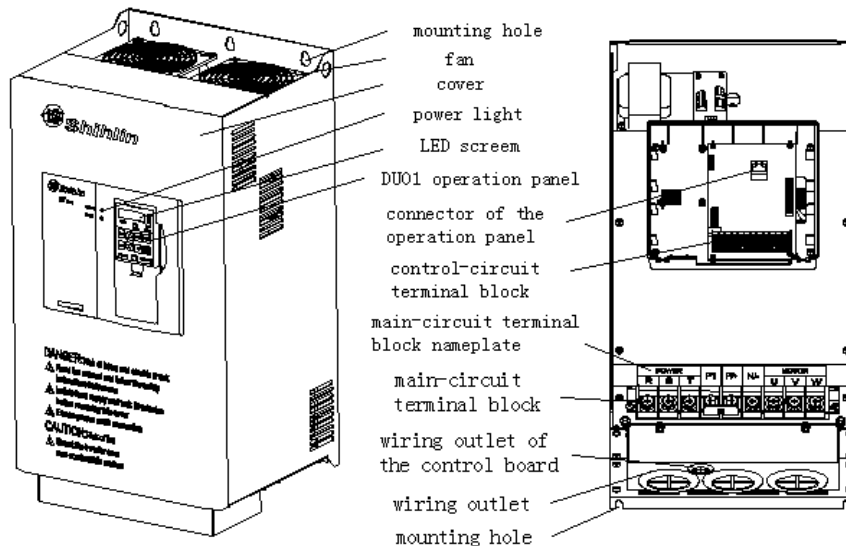

1. The above figure corresponds to all the models of frame D, E and F.
2. Push down the latch on the top cover and pull the latch toward the front of the inverter to remove the top cover.
3. “Wiring Outlet” is designed for fixing and protecting the lead wire. When wiring, the lead wire must passed through the “wiring outlet” and then connected to the terminals. Use cable ties to fix the wires in a bundle.

## 3.4.5 Each Type of Main Loop Terminals Arrangement

- Terminal arrangement

Note: 1. Frame A

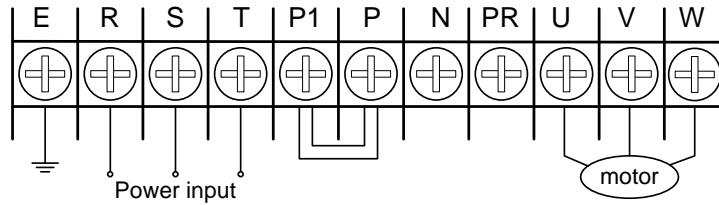

2. Frame B

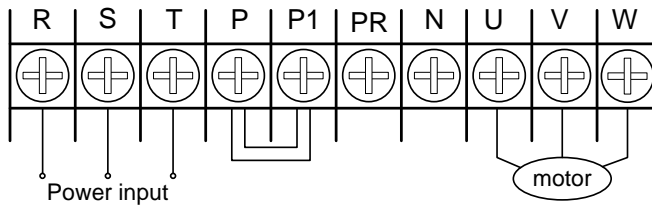

3. Frame C

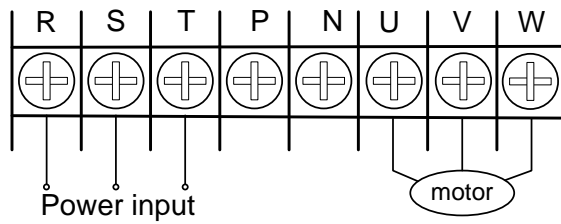

4. Frame D, E and F

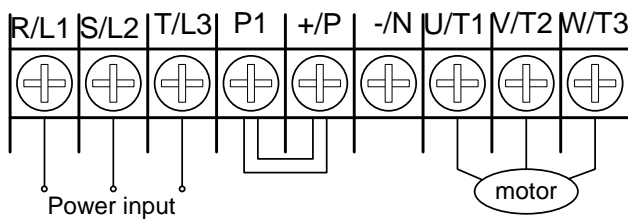

- DC reactor connection

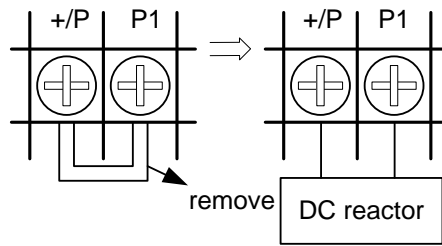

Note: Frame C, E and F corresponded inverters have built-in DC reactor.

- Brake unit connection

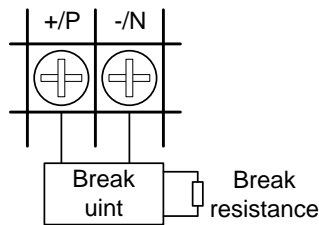

Note: Frame C, D, E and F corresponded inverters have no built-in brake unit. Brake units and brake resistors can be selected for use. The built-in brake unit of frame A and B corresponded inverters can have brake resistors.

Note: Instruction on the frames is presented in Section 3.3.

## **3.5 Installation and Wiring**

---

### 3.5.1 Transportation

Take the pedestal when carrying and don't only take the cover or any part of the inverter, otherwise it may drop down.

### 3.5.2 Stockpile

Keep this product in the packaging before installation and when not in use. To change the frequency that meets the manufacturer's warranty and maintenance conditions, please pay attention to the following regarding storage:

1. Must be placed in dry and without dirt place.
2. The environment temperature for storage position must range from  $-20^{\circ}\text{C}$  to  $+65^{\circ}\text{C}$ .
3. The relative humidity for storage position must range from 0% to 95%, and no condensation.
4. Avoid storing in the environment which contains corrosion gas or liquid.
5. It had better be packed properly and kept on shelf or table.

**Note:** 1. Even if the humidity meets the standard requirements, icing and condensation can also occur when the temperature changes rapidly. And the place should avoid.

2. Don't place it on the ground, and it should be placed on appropriate shelf. If in the bad surroundings, the desiccant should be placed in the packaging bag.

3. If the custody period is more than 3 months, the ambient temperature should not be higher than  $30^{\circ}\text{C}$ . It is to consider that the character will easily degrade in high temperature when the electrolytic capacitors are deposited without electricity.

4. If the inverter is installed in device or control board when not in use (especially in construction site or the humid and dusty place), the inverter should be removed and put in suitable environment according with the above storage conditions.

5. If the electrolytic capacitors are long-term no electricity, the character will degrade. Do not place it in the state of no electricity for more than one year.

### 3.5.3 EMC Installation Instructions

Just as other electrical and electronic equipments, an inverter is the source of electromagnetic interference and an electromagnetic receiver when working with a power system. The amount of electromagnetic interference and noise is determined by the working principles of an inverter. In order to guarantee the inverter working reliably in the electromagnetic environment, it must have a certain ability of anti-electromagnetic interference in design. In order to make the drive system work normally, and meet CE declared requirements, please meet the following several aspects requirements in installation:

## 1. Field wiring

Power line supply electric independently from power transformer, five core or four core line are generally used, null line and ground sharing a single line is forbidden.

Commonly signal wire (weak) and power wire (heavy) are in control cabinet, for the inverter, power wire is divided into input line and output line. Signal wire is easily interfered by power wire, so that causing the misoperation of the device. When wiring, signal wire and power wire should be distributed in different areas, parallel lines and interlaced lines are forbidden at close range (within 20cm), and especially don't bundle up the two lines. If the signal cables must pass through the power lines, the two should keep 90 degree Angle. Interlace lines and banding together is also forbidden for the input and output line of power wire, especially on the occasions which noise filter is installed. It will cause the coupling of electromagnetic noise through the distributed capacitance of the input and output lines, thus the noise filter will out of action.

Generally a control cabinet has different electric equipments such as inverter, filter, PLC, measurement instrument, their ability of emitting and bearing electromagnetic noise are diverse from each other, and this requires classifying these equipments. The classification can be divided into strong noise equipment and noise sensitive equipment, Install the similar equipments in the same area and, and keep a distance more than 20cm among inhomogeneous equipments.

## 2. Input noise filter, input and output magnet ring (Zero phase reactor)

Adding noise filter to the input terminal, the inverter will be isolated from the other equipments, and its ability of conduction and radiation will be reduced effectively. The better EMI suppression effect will be obtained by installing the input reactor recommended by this manual. By adding winding ferrite bead to the input and output terminal and coordinating with internal filter, the inverters will meet the CE declared and have a better effect.

## 3. Shielding

Good shielding and grounding can greatly reduce the interference of inverter, and can improve the anti-interference ability of the inverter. Sealing off the inverter with the good conductive sheet metal and connecting the sheet metal to ground, the limit value of radiation which CE declared will be met.

## 4. Grounding

The inverter must be connected to the ground safely and reliably. Grounding is not only for equipment and personal safety, but also the simplest, the most efficient and the lowest cost method to solving the EMC problem, so it should be prioritized. Please refer to the section of "terminal wiring".

## 5. Carrier wave

The leakage current contains the leakage current from line to line or over the ground. It depends on the size of the distributed capacitance when wiring and the carrier frequency of the frequency. The higher the carrier frequency, the longer the motor cable, and the larger the cable cross-sectional area is, the larger the leakage current is. Reducing the carrier frequency can effectively reduce the leakage current. When the motor line is long (50m above), the output side should be installed with ac reactor or sine wave filter, when the motor line is longer, a reactor should be installed every other distance. At the same time, reducing carrier frequency can effectively reduce the conduction and radiation interference, and the limits value of the conduction and radiation which CE declared can be met in 2K carrier frequency.

## 3.5.4 Installation

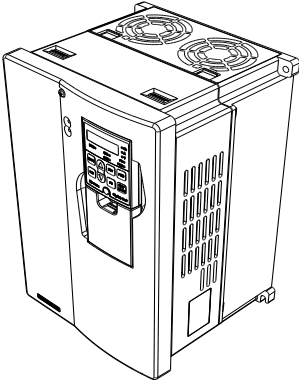
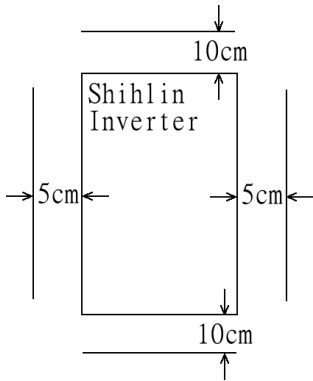
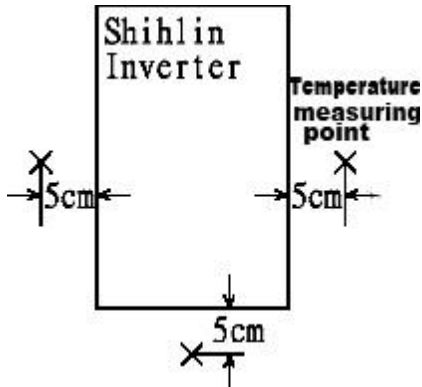
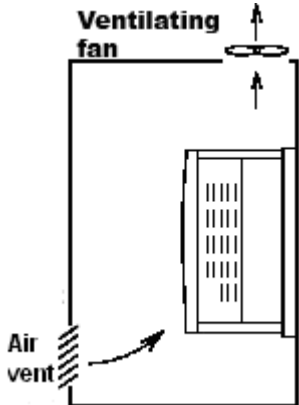
<p>1. Please install it upward.</p> 	<p>2. Install the inverter with sufficient space at the surroundings.</p> 
<p>3. The ambient temperature shall not exceed the permissible value.</p> 	<p>4. Install the inverter at a correct position in a protection case.</p> 
<p>5. Please do not install the inverter on a surface of inflammable material such as wood, etc.          6. Please do not install the inverter at place exposed to explosive gas or inflammable dust.          7. Please do not install the inverter at places with airborne oil mist and dust.          8. <b>Please do not install the inverter at places exposed to corrosive gas or high salt air.</b>          Please do not install the inverter in an environment of high temperature and high humidity.</p>	

Note: 1. The installation, wire arrangement, dismounting, and maintenance can only be done by qualified electricians.  
 2. Please follow the installation instructions. In the event where installation instructions have not been followed that resulted in damage of the inverter or dangerous accident, the manufacturer shall not be held responsible for any legal responsibility. Please feel free to contact us should you have any question.

## 3.5.5 System Wire Arrangement

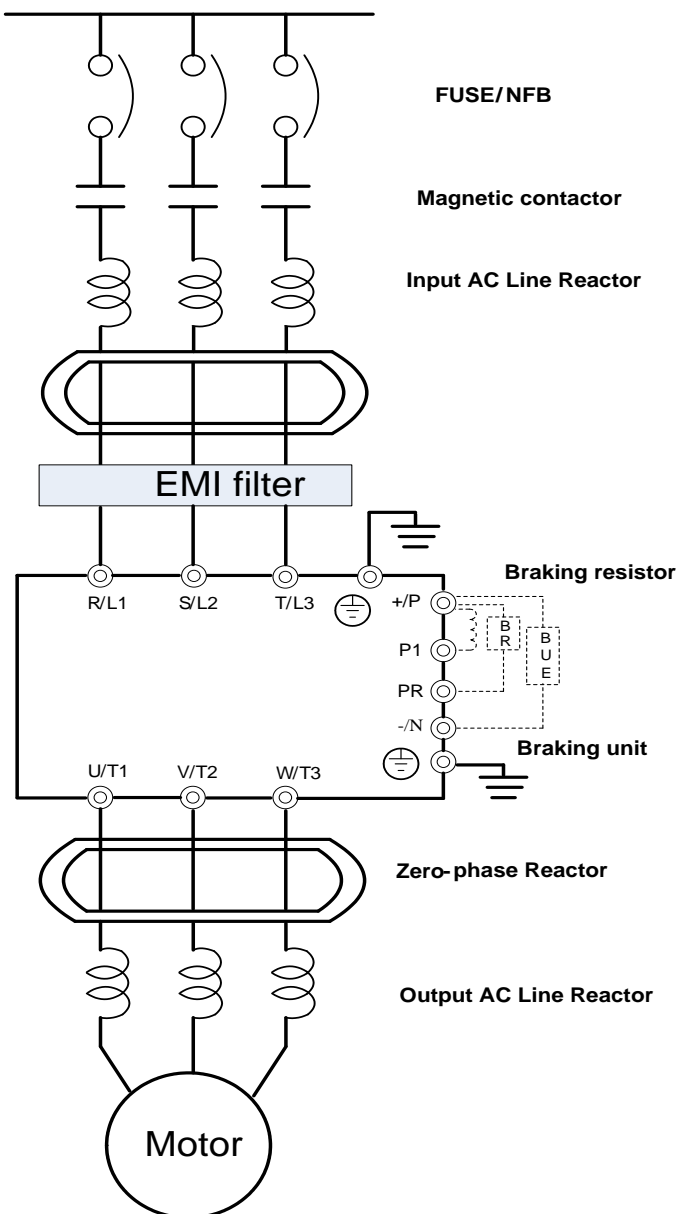

Power supply	Please follow the specific power supply requirement shown in this manual.
Fuse/NFB	There may be an inrush current during power up. Please refer to 3.7.1 and select the correct fuse /NFB.
Magnetic contactor	Please do not use a Magnetic contactor as the I/O switch of the inverter, as it will reduce the operating life cycle of the inverter.
Input AC Line Reactor	AC line reactor should be installed to improve the input power factor. The wiring distance should be less than 10m. Please refer to 3.7.6.
Zero-phase Reactor	Zero-phase reactors are used to reduce radio noise especially when audio equipment installed near the inverter. Effective for noise reduction on both the input and output sides. Attenuation quality is good for a wide range from AM band to 10MHz. Please refer to 3.7.5.
EMI filter	Used to reduce electromagnetic interference.
Braking unit	Used to reduce stopping time of the motor.
Output AC Line Reactor	Motor surge voltage amplitudes depending on motor cable length. The output AC line reactor is necessary to install on the inverter output side. Please refer to 3.7.6.

## 3.5.6 Terminal Wire Arrangement

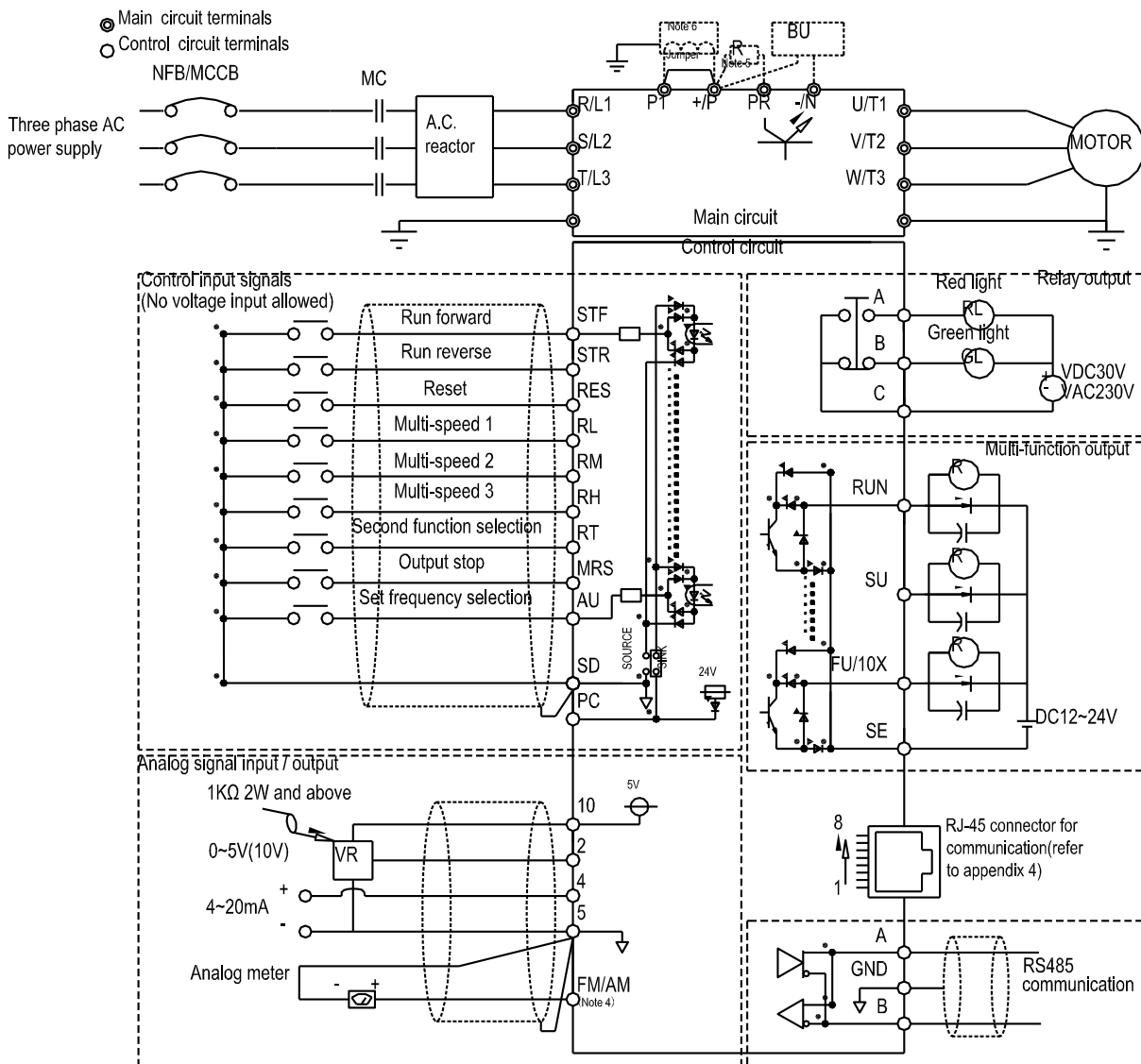

=====**Caution:**=====

1. Please refer to [P.80~P.84](#), [P.86](#) and [P.126~P.128](#) (OH) of Chapter 5 for the applications of external thermal overload relay.
2. Make sure not to short PC and SD.
3. The AC resistor between **+/P** and P1 is optional. Please short **+/P** and P1 when AC resistor is not used.
4. When selecting FM function for the FM/AM output terminal, the reference ground is SD. For more details, please refer to [P.64](#).
5. The brake resistor connection approach between **+/P** and PR is for frames A and B only. For connecting the brake unit of frame C, D, E, F to between **+/P** and **-/N**, please refer to terminal arrangement in [3.4.5](#)
6. **Inverters corresponding to frame C、E、F have build-in DC reactors, you can also refer to DC reactor specification on page [33](#) before adding DC reactors in addition.( When adding DC reactors,please remove the short circuit piece between P1 and +/P.)**

=====

Note: 1. For the function of the multi-function control terminals, please refer to [P.80~P.84](#), [P.86](#) and [P.126~P.128](#); For the multi-function output terminals, please refer to [P.40](#), [P.85](#), [P.129](#) and [P.130](#).

2. The multi-function control terminal of SF-Type series inverter can select the sink input approach or the source input approach via the jumper. When the jumper is on the left side, "sink input" mode is chosen, and when the jumper is on the right side, "source input" mode is chosen. See the figure below:



Sink Input Approach

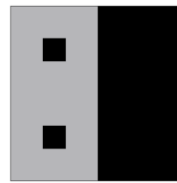

Source Input Approach

No matter what kind of multi-function control terminal is, all of its outside wire arrangement can be considered as a simple switch. If the switch is "on," the control signal will be put into the terminal. If the switch is "off," the control signal is shut off.

If "Sink Input" mode is selected, the function of the terminal is active when it is shorted with SD or connected with the external PLC. In this mode, the current flows out of the corresponding terminal when it is "on". Terminal "SD" is common to the contact input signals. When using an external power supply for output transistor, please use terminal PC as a common to prevent misoperation caused by leakage current.

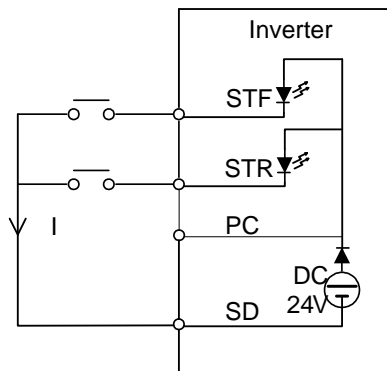

Sink Input: the multi-function control terminal is shorted directly with SD

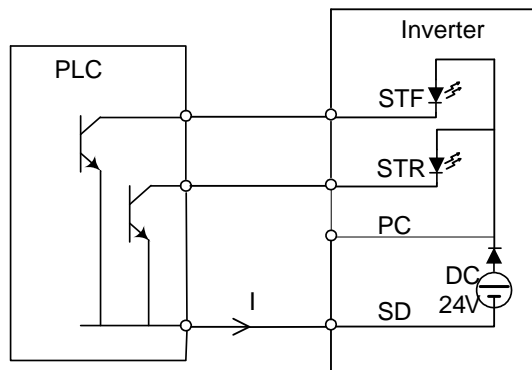

Sink Input: the multi-function control terminal is connected directly with open-collector PLC

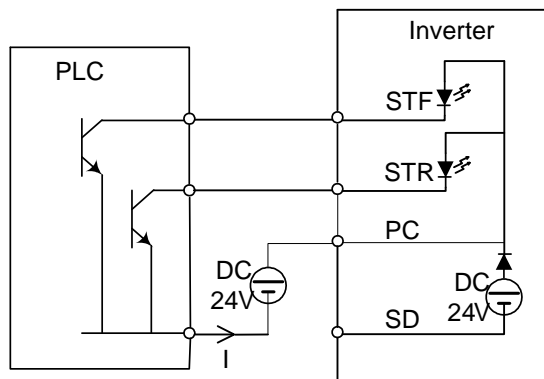

Sink Input: the multi-function control terminal is connected with open-collector PLC and external power supply

If "Source Input" mode is selected, the function of the terminal is active when it is shorted with PC or connected with the external PLC. In this mode, the current flows into the corresponding terminal when it is "on". Terminal PC is common to the contact input signals. When using an external power supply for transistor, please use terminal SD as a common to prevent misoperation caused by leakage current.

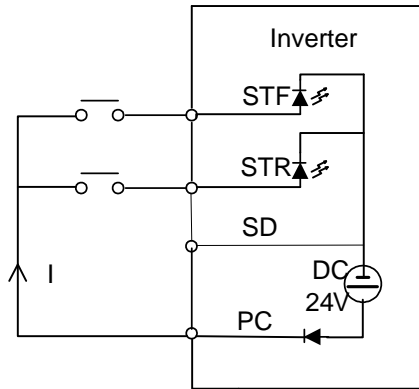

Source Input: the multi-function control terminal is shorted directly with PC

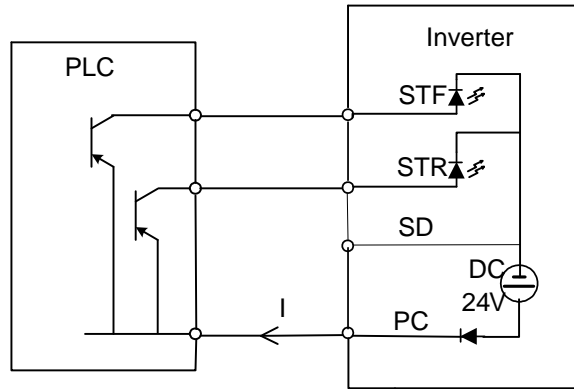

Source Input: the multi-function control terminal is connected directly with open-emitter PLC

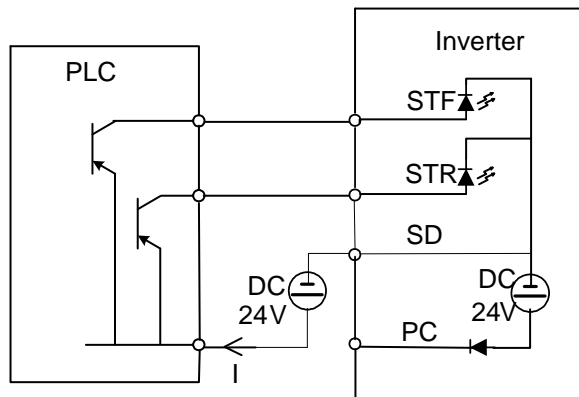

Source Input: the multi-function control terminal is connected with open-emitter PLC and external power supply

Main-circuit terminals	
R/L1-S/L2-T/L3	Connect to the commercial power supply
U/T1-V/T2-W/T3	Connect to the three-phase squirrel-cage motor.
+P-P1	Add to the DC reactor.
+P-PR	Connect to the brake resistor. (Note 1, 2)
(+P)-(-N)	Connect to the brake unit. (Note 3)
	Connect the enclosure of the inverter to ground. / For 440V series, special type of grounding shall be adopted. (Note 4)

Note: 1. For SF-Type series of inverters, brake resistor is not included. For information related to braking resistor, please refer to section 3.4.5 and 3.7.3.

2. For information related to regenerative voltage, please refer to P.30 in Chapter 5.

3. +P and -N are the positive and negative terminals of the internal DC voltage of the inverter. In order to strengthen the braking capacity during deceleration, it is suggested to purchase the optional “brake unit” which is mounted between the terminals +P and -N. The “brake unit” can effectively dissipate the feedback energy from the motor to the inverter when decelerating. In case there is any problem on purchasing the “brake unit,” please feel free to contact us.

For safety and to reduce noise, the grounding terminal  of the inverter must be well grounded.

To avoid electric shocks and fire accident, external metal wire of electrical equipment should be short and thick, and should be connected to special grounding terminals of an inverter. If several inverters are placed together, all inverters must be connected to the common ground. Please refer to the following diagrams and ensure that no circuit is formed between grounding terminals.

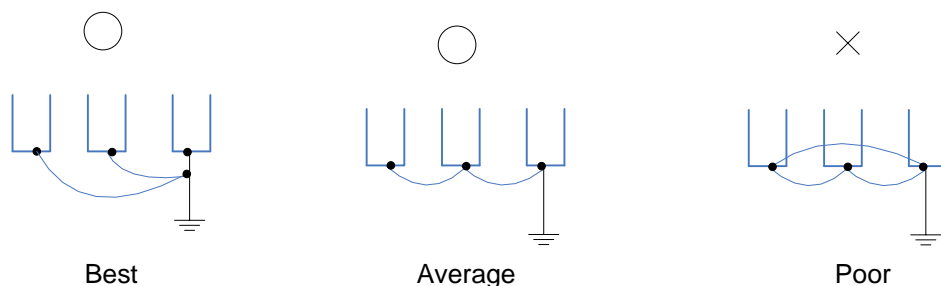

Control terminals			
Terminal type	Terminal name	Function name	Remarks and function description
Switch Signal Input	STF	Optional	These terminals are multi-function control terminals (SINK/SOURCE mode is optional). For detailed descriptions, please refer to <a href="#">P.80~P.84</a> , <a href="#">P.86</a> and <a href="#">P.126~P.128</a> , in Chapter 5.
	STR	Optional	
	RL	Optional	
	RM	Optional	
	RH	Optional	
	AU	Optional	
	RT	Optional	
	MRS	Optional	
	RES	Optional	
	SD	SD	Common reference ground for STF, STR, RL, RM, RH, AU, RT, MRS, RES and FM.
PC	PC	In the "Source Input" mode, a common power supply for the terminals referred above is given.	
Analog signal input	10	---	The internal power is 5V at this terminal.
	2	---	The input of voltage signal 0~5V or 0~ 10v; it is used to set the target frequency. <a href="#">P.38</a>
	4	---	The input of current signal 4~20mA; it is used to set the target frequency. <a href="#">P.39</a>
	5	---	The common reference ground of 10, 2, 4 and AM.
Relay Output	A	---	Normally, A-C are normal open, and B-C are normal closed. These terminals are multi-function relay output. Please refer to <a href="#">P.85</a> . Contact capacity VDC30V / VAC230V-0.3A.
	B	---	
	C	---	
Open collector output	SU	Optional	The terminals can also be called "multi-function output terminals". The function name can be set by <a href="#">P.40</a> , <a href="#">P.129~P.130</a> . For detailed description, please refer to <a href="#">P.40</a> , <a href="#">P.129~P.130</a> in Chapter 5.
	RUN	Optional	
	FU/10X	Optional	
	SE	SE	Open collector output reference ground.
Analog / pulse output terminal	AM/FM	---	Connected with a frequency meter or an external analog meter to indicate the output frequency or current. Permissible current load: 1mA, 1440 pulse/sec at 60Hz. Please refer to <a href="#">P.54</a> , <a href="#">P.55</a> , <a href="#">P.56</a> , <a href="#">P.64</a> , <a href="#">P.187</a> , <a href="#">P.190</a> , and <a href="#">P.191</a> in Chapter 5.
Communication terminal	A/GND/B	---	<a href="#">RS485 connector for inverter communication with PC/PLC.</a>

## 3.5.7 Wiring Precautions

### Main circuit wiring:

1. Do not connect the power supply wires to the “motor connecting terminal U/T1-V/T2-W/T3” or the inverter may be damaged.
2. Please do not mount phase advance capacitor, surge absorbers and electromagnetic contactors at the output terminal of the inverter.

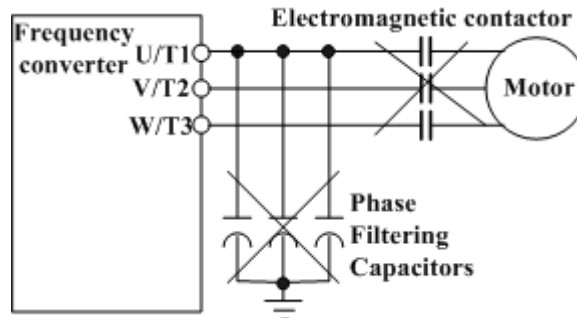

3. Please do not use “electromagnetic contactors” or “no-fuse switches” with an online power to start or stop the motor.
4. Please ensure that the case of the inverter and of the motor are grounded to avoid personnel electric shock.
5. To select appropriate diameter of the main wires and specification of the pressing connection terminal, the no-fuse switch and the electromagnetic contactor, please refer to Section 3.7. If the inverter is far away from the motor, please employ a wire with larger diameter to ensure the voltage drop along the wire is within 2V. (The total length of the wire shall not exceed 500 m)
6. “Pressing connection terminals with insulated sleeve” shall be utilized for the wiring at the power source side and the load side.
7. In a short period after the power supply is shut off, high voltage still exists between terminals (+/P)-(-/N), so do not touch them within 10 minutes to avoid electric shock.

### Control circuit wiring arrangement:

1. For wiring of signal input, use only “insulated wires” with the “metal mesh” corrected grounded.
2. The use of 0.75mm<sup>2</sup> diameter wire is recommended. For stripping the insulating layer, please comply with the instruction of the following picture.

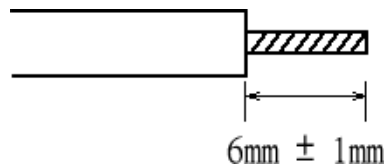

3. Control board wires (including signal input wire) should be far away from the main circuit board wires. Binding the control board wires together with the main circuit wires is strictly forbidden.
4. In the inverter, “terminal SD”, “terminal SE” and “terminal 5” are the referencing grounds for the inner power sources, which are isolated from each other.
5. The best torque force for locking the control line is 2Kgf.cm.

- Note: 1. Terminal block screws must be fastened tightly. Do not leave any off-cut wire pieces inside the inverter.
2. The installation, wire arrangement, dismounting, and maintenance can only be done by qualified electricians.
3. Please follow the installation instructions. In the event where installation instructions have not been followed that resulted in damage of the inverter or dangerous accident, the manufacturer shall not be held responsible for any legal responsibility. Please feel free to contact us should you have any question.

## 3.6 Mini Jumper Instruction

Main power isolated from earth:

1. If the inverter is supplied with a non-grounded power supply (IT power), the Mini Jumper must be cut off to prevent circuit damage (according to IEC61800-3) and reduce earth leakage current.
2. Do not cut off the Mini Jumper if the input filter is active. This will increase earth leakage current.
3. Cut off the Mini Jumper if the earth leakage current is overlarge. This will decrease the filtering effect.

The Mini Jumper is shown as follows:

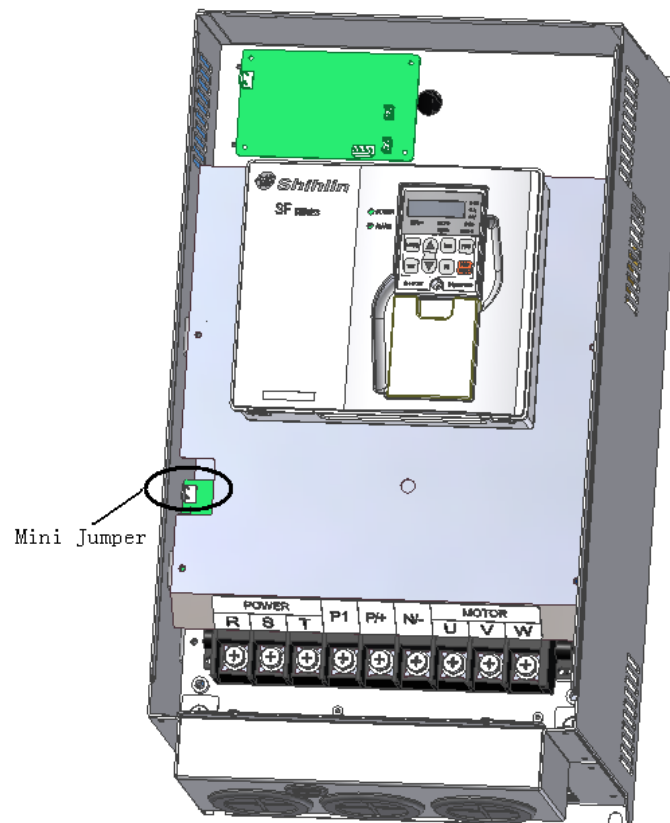

====Caution:=====

1. Do not cut off the Mini jumper after applying power to the inverter. Please make sure that the main power has been switched off before cutting of the Mini Jumper.
2. Electric conductivity of the capacitor will be cut off by cutting off the Mini Jumper. Moreover, the electromagnetic capacitance of the inverter will be reduced by cutting of the Mini Jumper.
3. Do not switch off the Mini Jumper when the main power is a grounded power system. To prevent machine damage, the Mini Jumper shall be cut off if the inverter is installed on an ungrounded power system, a high resistance-grounded (over 30 ohms) power system, or a corner grounded TN system.
4. Mini jumper cannot be cut off when performing the Hi-pot tests.
5. The Mini Jumper is exclusively for frame C, D, E and F corresponded models (Please refer to Section [3.3](#) for frame description).

====

## 3.7 Selection of Peripheral Equipment

### 3.7.1 No-fuse switch

Inverter type	Motor capacity	Power source capacity	Applicable no-fuse switch (NFB/MCCB) type (Shihlin Electric)	Applicable electromagnetic contactor (MC) type (Shihlin Electric)
SF-020-5.5K	220V 7.5HP	12 KVA	BM60SN3P50A	S-P25
SF-020-7.5K/5.5K-G	220V 10HP	17 KVA	BM60SN3P60A	S-P25
SF-020-11K/7.5K-G	220V 15HP	20 KVA	BM100SN3P100A	S-P35
SF-020-15K/11K-G	220V 20HP	28 KVA	BM160SN3P125A	S-P50
SF-020-18.5K/15K-G	220V 25HP	34 KVA	BM160SN3P160A	S-P65
SF-020-22K/18.5K-G	220V 30HP	41 KVA	BM250SN3P175A	S-P80
SF-020-30K/22K-G	220V 40HP	52 KVA	BM250SN3P225A	S-P90
SF-020-37K/30K-G	220V 50HP	65 KVA	BM250SN3P250A	S-P150
SF-020-45K/37K-G	220V 60HP	79 KVA	BM400SN3P300A	S-P180
SF-020-55K/45K-G	220V 75HP	99 KVA	BM400SN3P350A	S-P220
SF-040-5.5K	440V 7.5HP	11.5 kVA	BM30SN3P30A	S-P21
SF-040-7.5K/5.5K-G	440V 10HP	16 kVA	BM30SN3P30A	S-P21
SF-040-11K/7.5K-G	440V 15HP	20 kVA	BM60SN3P50A	S-P30T
SF-040-15K/11K-G	440V 20HP	27 kVA	BM60SN3P60A	S-P40T
SF-040-18.5K/15K-G	440V 25HP	32 kVA	BM100SN3P75A	S-P40T
SF-040-22K/18.5K-G	440V 30HP	41 kVA	BM100SN3P100A	S-P50T
SF-040-30K/22K-G	440V 40HP	52 kVA	BM160SN3P125A	S-P50
SF-040-37K/30K-G	440V 50HP	65 kVA	BM160SN3P160A	S-P65
SF-040-45K/37K-G	440V 60HP	79 kVA	BM250SN3P175A	S-P80
SF-040-55K/45K-G	440V 75HP	100kVA	BM250SN3P250A	S-P80
SF-040-75K/55K-G	440V 100HP	110kVA	BM400SN3P300A	S-P150
SF-040-90K/75K-G	440V 120HP	137kVA	BM400SN3P300A	S-P150
SF-040-110K/90K-G	440V 150HP	165kVA	BM400SN3P400A	S-P150
SF-040-132K/110K-G	440V 175HP	198kVA	BM600SN3P500A	S-P300
SF-040-160K/132K-G	440V 215HP	247kVA	BM600SN3P630A	S-P300

## 3.7.2 Power cable specification / pressing connection terminal specification

Inverter type	Power cable specification				Pressing connection terminal specification (used by power cables)	
	Power supply terminal (R/L1.S/L2.T/L3)		Loading terminal (U/T1.V/T2.W/T3)		Cables for power supply (R/L1.S/L2.T/L3)	Cables for loading (U/T1.V/T2.W/T3)
	Crimping terminal (mm <sup>2</sup> )	Tightening torque (Kgf.cm)	Crimping terminal (mm <sup>2</sup> )	Tightening torque (Kgf.cm)		
SF-020-5.5K	5.5	30	5.5	30	5.5 - 5	5.5 - 5
SF-020-7.5K/5.5K-G	14	30	8	30	14 - 5	8 - 5
SF-020-11K/5.5K-G	14	30	14	30	14 - 6	14 - 6
SF-020-15K/11K-G	22	30	22	30	22 - 6	22 - 6
SF-020-18.5K/15K-G	38	30	38	30	38 - 6	38 - 6
SF-020-22K/18.5K-G	38	30	38	30	38 - 6	38 - 6
SF-020-30K/22K-G	60	200	60	200	60 - 6	60 - 6
SF-020-37K/30K-G	80	200	80	200	80 - 10	80 - 10
SF-020-45K/37K-G	100	200	100	200	100 - 10	100 - 10
SF-020-55K/45K-G	100	200	100	200	100 - 10	100 - 10
SF-040-5.5K	3.5	30	2	18	3.5 - 5	2 - 5
SF-040-7.5K/5.5K-G	3.5	30	3.5	30	3.5 - 5	3.5 - 5
SF-040-11K/7.5K-G	5.5	30	5.5	30	5.5 - 5	5.5 - 5
SF-040-15K/11K-G	14	30	8	30	14 - 5	8 - 5
SF-040-18.5K/15K-G	14	30	8	30	14 - 6	8 - 6
SF-040-22K/18.5K-G	22	30	14	30	22 - 6	14 - 6
SF-040-30K/22K-G	22	30	22	30	22 - 8	22 - 8
SF-040-37K/30K-G	22	30	22	30	22 - 8	22 - 8
SF-040-45K/37K-G	38	30	38	30	38 - 8	38 - 8
SF-040-55K/45K-G	60	200	60	200	60 - 10	60 - 10
SF-040-75K/55K-G	60	200	60	200	60 - 10	60 - 10
SF-040-90K/75K-G	60	200	60	200	60 - 10	60 - 10
SF-040-110K/90K-G	80	200	80	200	80 - 10	80 - 10
SF-040-132K/110K-G	100	200	125	300	100 - 10	125 - 10
SF-040-160K/132K-G	125	300	125	300	125 - 10	125 - 10

## 3.7.3 Retrograde Brake Resistor

Inverter type	Retrograde brake resistor specification	Inverter type	Retrograde brake resistor specification
SF-020-5.5K	1000W 25Ω or above	SF-040-5.5K	1000W 75Ω or above
SF-020-7.5K/5.5K-G	1200W 20Ω or above	SF-040-7.5K/5.5K-G	1200W 75Ω or above
SF-020-11K/7.5K-G	2400W 13.6Ω or above	SF-040-11K/7.5K-G	2400W 50Ω or above
SF-020-15K/11K-G	3000W 10Ω or above	SF-040-15K/11K-G	3000W 40Ω or above
SF-020-18.5K/15K-G	4800W 8Ω or above	SF-040-18.5K/15K-G	4800W 32Ω or above
		SF-040-22K/18.5K-G	4800W 27.2Ω or above

- Note: 1. For brake resistor whose built-in brake unit offers model options, the capacity of the regenerative brake is based on the condition that the regenerative brake duty is 10% (when braking lasts for 5 seconds, the machine has to be stopped for another 45 seconds must be stopped for heat dissipation). For models without a built-in brake unit, the capacity of the regenerative brake is based on the brake duty of the selected brake unit. The regenerative brake resistor wattage can be reduced according to the user's application (quantity of heat) and the regenerative brake duty. But the resistance must be larger than the value (ohms) listed in the above table (otherwise the inverter will be damaged).
2. In case frequent start and stop operations are required, a larger regenerative brake duty should be set. Meanwhile, a large brake resistor should be employed correspondingly. Please refer to Section 3.4.5 and 3.7.3 for selecting and purchasing the regenerative brake resistors. Please feel free to contact us if there is any problem regarding the selection of brake resistors.
3. Frame C, D, E and F corresponded inverters have no built-in brake unit. Please select and purchase an external brake unit according to the brake unit section in the manual.

## 3.7.4 Reactor

- AC input reactor

3-Phase, 220V, 50/60Hz

Inverter type	kW	HP	Rated Amps of reactor	Rated reactor Amps	Inductance (mH)	
					2% impedance	4% impedance
SF-020-5.5K	5.5	7.5	24	30	0.6	0.93
SF-020-7.5K/5.5K-G	7.5/5.5	10/7.5	32	40	0.42	0.7
SF-020-11K/7.5K-G	11/7.5	15/10	45	60	0.28	0.47
SF-020-15K/11K-G	15/11	20/15	60	80	0.19	0.35
SF-020-18.5K/15K-G	18.5/15	25/20	73	90	0.19	0.31
SF-020-22K/18.5K-G	22/18.5	30/25	91	120	0.13	0.23
SF-020-30K/22K-G	30/22	40/30	110	150	0.11	0.19
SF-020-37K/30K-G	37/30	50/40	150	200	0.08	0.14
SF-020-45K/37K-G	45/37	60/50	180	250	0.065	0.11
SF-020-55K/45K-G	55/45	75/60	220	250	0.065	0.11

3-Phase, 440V, 50/60Hz

Inverter type	kW	HP	Rated Amps of reactor	Rated reactor Amps	Inductance (mH)	
					2% impedance	4% impedance
SF-040-5.5K	5.5	7.5	13	15	1	1.9
SF-040-7.5K/5.5K-G	7.5/5.5	10/7.5	18	20	0.75	1.4
SF-040-11K/7.5K-G	11/7.5	15/10	24	30	0.6	0.93
SF-040-15K/11K-G	15/11	20/15	32	40	0.42	0.7
SF-040-18.5K/15K-G	18.5/15	25/18.5	38	50	0.35	0.56
SF-040-22K/18.5K-G	22/18.5	30/25	45	60	0.28	0.47
SF-040-30K/22K-G	30/22	40/30	60	80	0.19	0.35
SF-040-37K/30K-G	37/30	50/40	73	90	0.19	0.31
SF-040-45K/37K-G	45/37	60/50	91	120	0.13	0.23
SF-040-55K/45K-G	55/45	75/60	110	150	0.11	0.19
SF-040-75K/55K-G	75/55	100/75	150	200	0.08	0.14
SF-040-90K/75K-G	90/75	120/100	180	250	0.065	0.11
SF-040-110K/90K-G	110/90	150/120	220	250	0.065	0.11
SF-040-132K/110K-G	132/110	175/150	260	290	0.05	0.096
SF-040-160K/132K-G	160/132	215/175	310	330	0.05	0.085

# Shihlin Inverter Introduction

- AC output reactor

3-Phase, 220V, 50/60Hz

Inverter type	kW	HP	Rated Amps of reactor	Rated reactor Amps	Inductance (mH)	
					4% impedance	2% impedance
SF-020-5.5K	5.5	7.5	24	30	0.23	0.46
SF-020-7.5K/5.5K-G	7.5/5.5	10/7.5	32	40	0.18	0.35
SF-020-11K/7.5K-G	11/7.5	15/10	45	60	0.12	0.23
SF-020-15K/11K-G	15/11	20/15	60	80	0.087	0.17
SF-020-18.5K/15K-G	18.5/15	25/20	73	90	0.078	0.17
SF-020-22K/18.5K-G	22/18.5	30/25	91	120	0.058	0.11
SF-020-30K/22K-G	30/22	40/30	110	150	0.047	0.09
SF-020-37K/30K-G	37/30	50/40	150	200	0.035	0.07
SF-020-45K/37K-G	45/37	60/50	180	250	0.028	0.055
SF-020-55K/45K-G	55/45	75/60	220	250	0.028	0.055

3-Phase, 440V, 50/60Hz

Inverter type	kW	HP	Rated Amps of reactor	Rated reactor Amps	Inductance (mH)	
					4% impedance	2% impedance
SF-040-5.5K	5.5	7.5	13	15	0.47	0.93
SF-040-7.5K/5.5K-G	7.5/5.5	10/7.5	18	20	0.35	0.7
SF-040-11K/7.5K-G	11/7.5	15/10	24	30	0.23	0.46
SF-040-15K/11K-G	15/11	20/15	32	40	0.18	0.35
SF-040-18.5K/15K-G	18.5/15	25/18.5	38	50	0.14	0.28
SF-040-22K/18.5K-G	22/18.5	30/25	45	60	0.12	0.23
SF-040-30K/22K-G	30/22	40/30	60	80	0.087	0.17
SF-040-37K/30K-G	37/30	50/40	73	90	0.078	0.17
SF-040-45K/37K-G	45/37	60/50	91	120	0.058	0.11
SF-040-55K/45K-G	55/45	75/60	110	150	0.047	0.09
SF-040-75K/55K-G	75/55	100/75	150	200	0.035	0.07
SF-040-90K/75K-G	90/75	120/100	180	250	0.028	0.055
SF-040-110K/90K-G	110/90	150/120	220	250	0.028	0.055
SF-040-132K/110K-G	132/110	175/150	260	290	0.024	0.048
SF-040-160K/132K-G	160/132	215/175	310	330	0.021	0.042

Note: It is recommended to use the AC input / output reactor which produced by SHANGHAI EAGTOP ELECTRONIC TECHNOLOGY CO., LTD

# Shihlin Inverter Introduction

- DC reactor specification

3-Phase, 220V, 50/60Hz

Inverter type	kW	HP	DCAmps	Inductance (mH)
SF-020-5.5K	5.5	7.5	33	1.9
SF-020-7.5K/5.5K-G	7.5/5.5	10/7.5	40	1.26
SF-020-11K/7.5K-G	11/7.5	15/10	33	1.9
SF-020-15K/11K-G	15/11	20/15	40	1.26
SF-020-18.5K/15K-G	18.5/15	25/20	78	0.72
SF-020-22K/18.5K-G	22/18.5	30/25	Built-in (not external connection)	—
SF-020-30K/22K-G	30/22	40/30	Built-in (not external connection)	—
SF-020-37K/30K-G	37/30	50/40	160	0.36
SF-020-45K/37K-G	45/37	60/50	180	0.33
SF-020-55K/45K-G	55/45	75/60	250	0.26

3-Phase, 440V, 50/60Hz

Inverter type	kW	HP	DCAmps	Inductance (mH)
SF-040-5.5K	5.5	7.5	12	6.3
SF-040-7.5K/5.5K-G	7.5/5.5	10/7.5	23	3.6
SF-040-11K/7.5K-G	11/7.5	15/10	33	1.9
SF-040-15K/11K-G	15/11	20/15	40	1.26
SF-040-18.5K/15K-G	18.5/15	25/18.5	50	1.08
SF-040-22K/18.5K-G	22/18.5	30/25	33	1.9
SF-040-30K/22K-G	30/22	40/30	40	1.26
SF-040-37K/30K-G	37/30	50/40	78	0.72
SF-040-45K/37K-G	45/37	60/50	95	0.54
SF-040-55K/45K-G	55/45	75/60	115	0.45
SF-040-75K/55K-G	75/55	100/75	160	0.36
SF-040-90K/75K-G	90/75	120/100	180	0.33
SF-040-110K/90K-G	110/90	150/120	250	0.26
SF-040-132K/110K-G	132/110	175/150	340	0.26
SF-040-160K/132K-G	160/132	215/175	340	0.18

Note: Frame C, E and F corresponded model have a built-in DC reactor. External reactors can be added, too, by referring to the above specification table.

## 3.7.5 Filter

- AC input filter

3-Phase, 220V, 50/60Hz

Inverter type	kW	HP	Rated Amps of reactor	Types of filter
SF-020-5.5K	5.5	7.5	24	096B.04001.00A
SF-020-7.5K/5.5K-G	7.5/5.5	10/7.5	32	096B.04001.00A
SF-020-11K/7.5K-G	11/7.5	15/10	45	096B.05001.00A
SF-020-15K/11K-G	15/11	20/15	60	096B.10001.00
SF-020-18.5K/15K-G	18.5/15	25/20	73	096B.10001.00
SF-020-22K/18.5K-G	22/18.5	30/25	91	096B.10001.00
SF-020-30K/22K-G	30/22	40/30	110	096B.18001.00S
SF-020-37K/30K-G	37/30	50/40	150	096B.18001.00S
SF-020-45K/37K-G	45/37	60/50	180	096B.18001.00S
SF-020-55K/45K-G	55/45	75/60	220	097.31001.00S

3-Phase, 440V, 50/60Hz

Inverter type	kW	HP	Rated Amps of reactor	Types of filter
SF-040-5.5K	5.5	7.5	13	096B.02001.00A
SF-040-7.5K/5.5K-G	7.5/5.5	10/7.5	18	096B.02001.00A
SF-040-11K/7.5K-G	11/7.5	15/10	24	096B.04001.00A
SF-040-15K/11K-G	15/11	20/15	32	096B.04001.00A
SF-040-18.5K/15K-G	18.5/15	25/18.5	38	096B.04001.00A
SF-040-22K/18.5K-G	22/18.5	30/25	45	096B.05001.00A
SF-040-30K/22K-G	30/22	40/30	60	096B.10001.00
SF-040-37K/30K-G	37/30	50/40	73	096B.10001.00
SF-040-45K/37K-G	45/37	60/50	91	096B.10001.00
SF-040-55K/45K-G	55/45	75/60	110	096B.18001.00
SF-040-75K/55K-G	75/55	100/75	150	096B.18001.00
SF-040-90K/75K-G	90/75	120/100	180	096B.18001.00
SF-040-110K/90K-G	110/90	150/120	220	097.31001.00S
SF-040-132K/110K-G	132/110	175/150	260	097.31001.00S
SF-040-160K/132K-G	160/132	215/175	310	097.31001.00S

Note: Products of LCR Electronics (Kunshan) Co., Ltd are recommended for the filter used here.

## 4. Primary Operation

### 4.1 Operating Modes of the Inverter

The operation modes are related to the reference source of the target frequency and the signal source of the motor starting. The Shihlin SF-TYPE inverter has a total of nine kinds of operation modes, namely, "PU mode", "JOG mode", "external mode", "communication mode", "combined mode 1", "combined mode 2", "combined mode 3", "combined mode 4" and "combined mode 5".

You can use DU01 operation panel to monitor the output frequency, the output voltage and the output current, as well as to view the alarm message, the parameter setting and the frequency setting. The operator has four work modes, namely, "operation mode", "monitoring mode", "frequency setting mode" and "parameter setting mode".

Related parameters	Values	Operation mode	The reference source of target frequency	The signal source of motor starting	Remarks
Operation mode selection P.79	0	PU mode	<b>DU01 operation panel</b>	The <b>FWD</b> or <b>REV</b> key of DU01 operation panel.	The "PU mode", "JOG mode" and "external mode" are interchangeable.
		JOG mode	The set value of P.15	The <b>FWD</b> or <b>REV</b> key of DU01 operation panel.	
		External mode	"External voltage/current signal", "combination of multi-speed stage levels" and external JOG (P.15)	<b>External forward and reverse terminals</b>	
			<b>Frequency of each section in the programmed operation mode (P.131~P.138)</b>	<b>External STF terminal</b>	
	1	PU mode	Equal to the "PU mode" when <u>P.79</u> = 0		The "PU mode" and "JOG mode" are interchangeable.
		JOG mode	Equal to the "PU mode" when P.79 = 0		
2	External mode	Equal to the "External mode" when P.79 = 0			

# Primary Operation

Primary operation

Related parameters	Values	Operation mode	The reference source of target frequency	The signal source of motor starting	Remarks
Operation mode selection P.79	3	Communication mode	<b>Communication</b>	<b>Communication</b>	
	4	Combined Mode 1	<b>DU01 operation panel</b>	<b>External forward and reverse terminals</b>	
	5	Combined Mode 2	“External voltage / current signal” and “combination of multi-speed stage levels”	The <b>FWD</b> or <b>REV</b> key of DU01 operation panel.	
	6	Combined Mode 3	Communication, “combination of multi-speed stage levels” and External JOG (P.15)	<b>External forward and reverse terminals</b>	
	7	Combined Mode 4	“External voltage / current signal” and “combination of multi-speed stage levels”	<b>Communication</b>	
	8	Combined Mode 5	DU01 operation panel, “combination of multi-speed stage levels” and External JOG (P.15)	<b>External forward and reverse terminals</b>	

When P.79=0, the external mode is the default mode after the inverter is turned on. Use P.79 to switch the operation mode.

# Primary Operation

## 4.1.1 The flow chart for switching the operation mode using DU01 operation panel

When P.79=0:

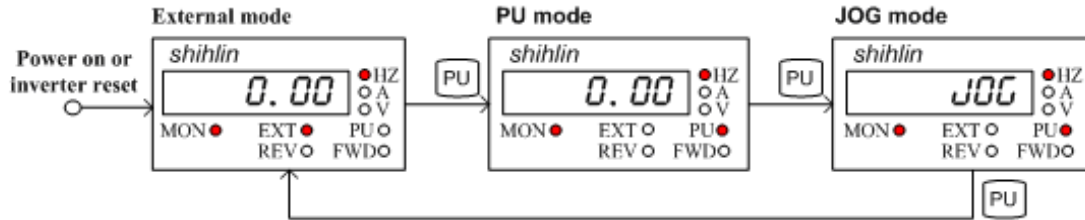

When P.79 = 1:

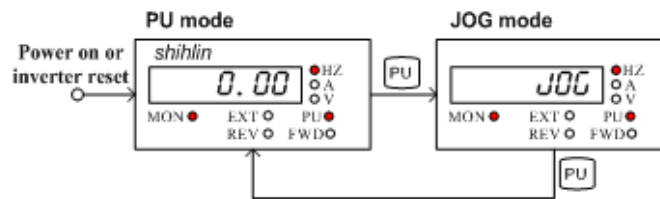

- Note: 1. In “PU mode,” the indicating lamp **PU** will light up on the operation panel.  
 2. In “external mode,” indicating lamp **EXT** will light up on the operation panel.  
 3. In “combined mode 1, 2, 3, 4, or 5,” the indicating lamp **PU** and **EXT** will light up.  
 4. In “JOG mode,” the indicating lamp **PU** will light up, and at the same time, the display screen will display *JOG* while the motor is not running.  
 5. No flow chart when P.79=2, 3, 4, 5, 6, 7 or 8 because the operation mode will be constant.

## 4.1.2 The flow chart for switching the working mode using DU01 operation panel

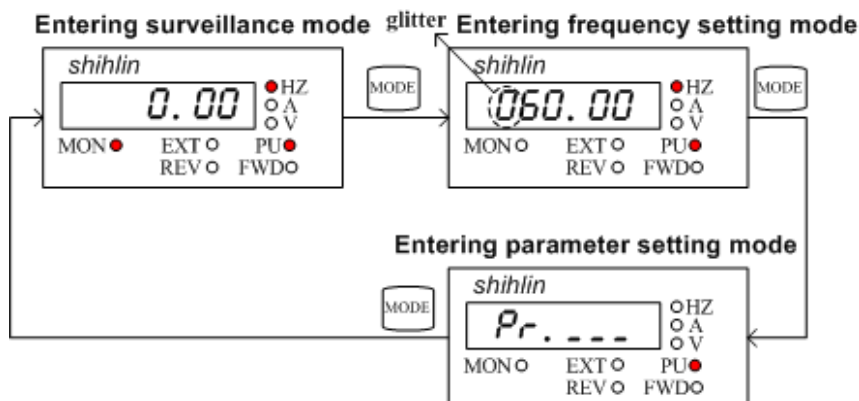

- Note: 1. Please refer to section 4.1.3 for the detailed operation flow under the monitoring mode.  
 2. Please refer to section 4.1.4 for the detailed operation flow under the frequency setting mode.  
 3. Please refer to section 4.1.5 for the detailed operation flow under the parameter setting mode.  
 4. Please refer to Section 4.1.2 for detailed operation flow under the switching operation mode.

## 4.1.3 Operation flow charts for monitoring mode with DU01

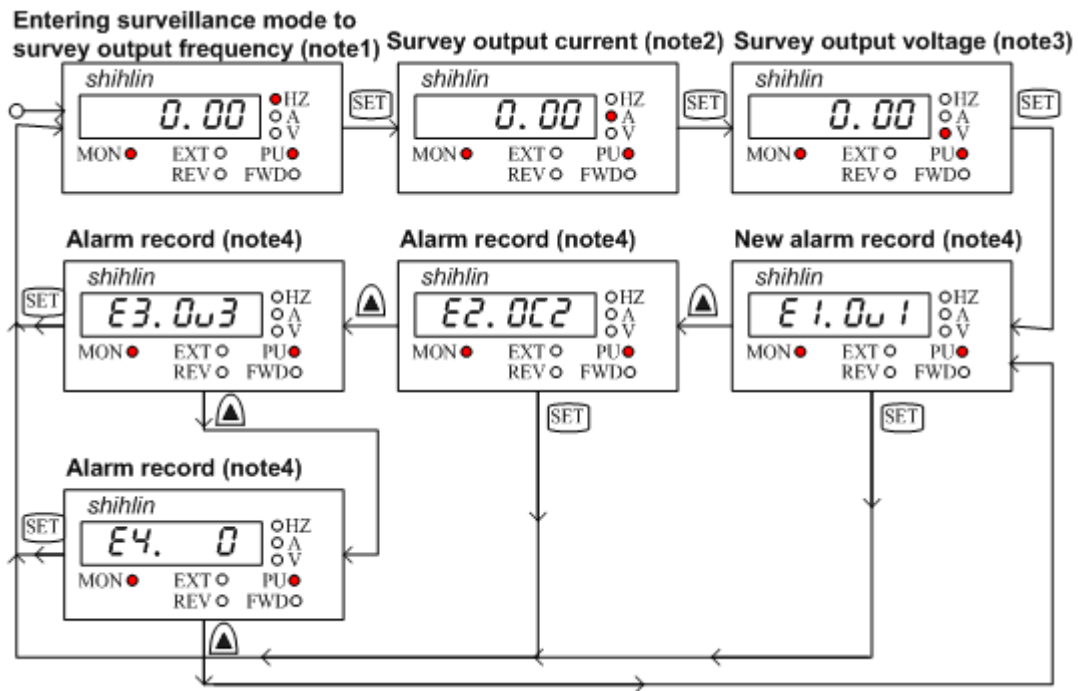

- Note: 1. In the “monitoring output frequency mode”, indicating lamp **MON** and **Hz** will light up, and the screen will display the current output frequency.
2. In the “monitoring output current mode”, indicating lamp **MON** and **A** will light up, and the screen will display the current output current.
3. In the “monitoring output voltage mode”, indicating lamp **MON** and **V** will light up, and the screen will display the current output voltage.
4. When in the “browsing alarm record mode,” indicating lamp **MON** will light up, and the screen will display the current alarm code.
5. For alarm codes, please refer to [Appendix 2](#).

## 4.1.4 Operation flow charts for frequency setting mode with DU01

Use ▲ or ▼ key for setting up the frequency.

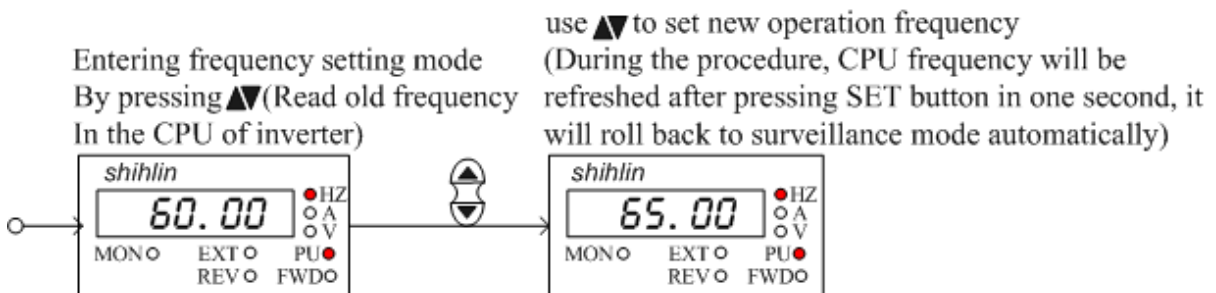

Press the MODE key to enter the frequency setting mode.

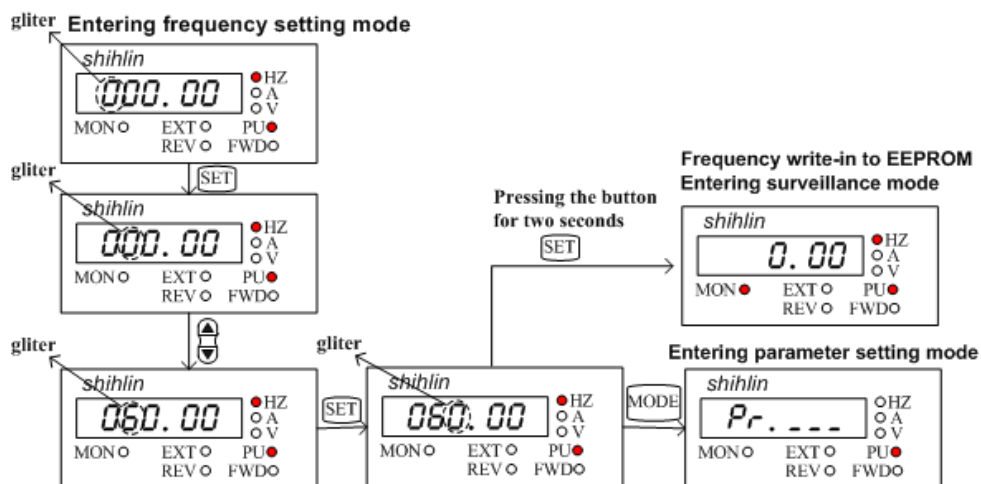



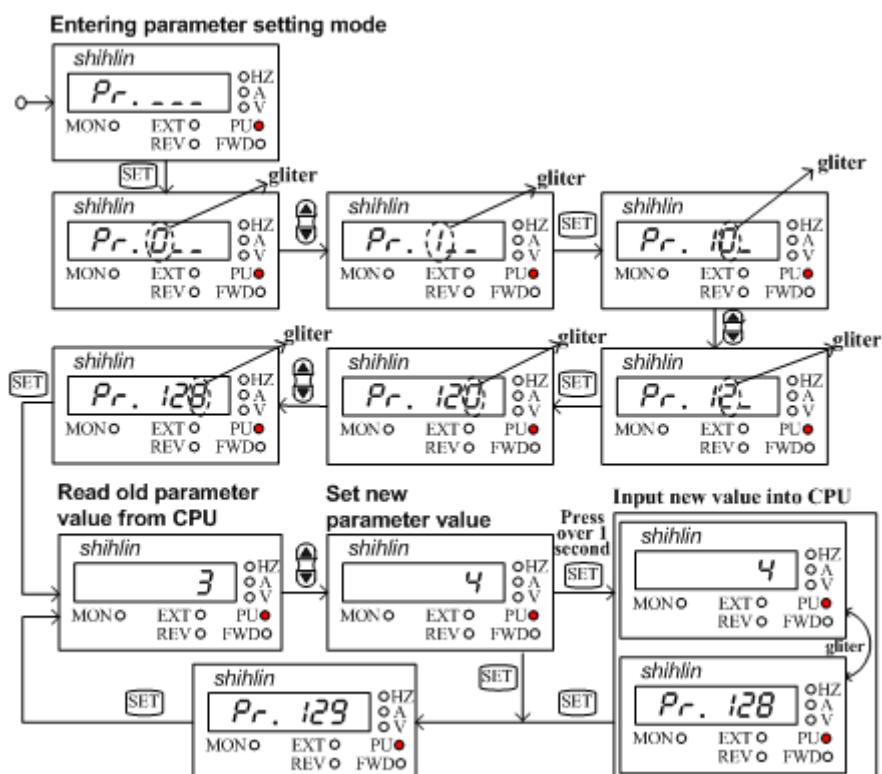

- Note: 1. Use ▲ or ▼ to change the frequency when the inverter is running.
2. Indicating lamp ●Hz will light up, but not ●MON under the frequency setting mode.
3. When setting the frequency under the PU mode, the set value can not exceed the upper frequency. When high frequency is needed, the upper frequency should be changed first.
4. When using the MODE key for setting the frequency, the operation panel will stay in the frequency setting mode if the SET key is not pressed within one second to save in input. The user will not return to the parameter setting mode and the monitoring mode until pressing the MODE key.

## 4.1.5 Operation flow charts for parameter setting mode with DU01











Note: 1. Indicating lamp **Hz** will light up, but not **MON** under the parameter setting mode.

2. When entering the value of a parameter, make sure to press the **SET** key for longer than 1 second.
3. When the parameter is set as 99999, the actual corresponded CPU value will be 65535. Therefore, if the value is set below 99999, the CPU value will gradually decrease from 65535. If so, the operation panel should display 65534, 65533... and so forth.
4. Similar to setting parameters, button  and  are used to increase or decrease the value. The panel will stop when the parameter reaches 99999(0). If there is a need to surpass this value, the user must press button  and  so the parameter value will then either increase to 0 or decrease to 99999.
5. When parameter setting is 99999, "9999" will be displayed on the operation panel of SF-PU series, while "99999" will be displayed on the operation panel of the DU series.

## 4.2 Basic Operation Procedures for Different Modes

### 4.2.1 Basic operation procedures for PU mode (P.79=0 or 1)

Step	Description
1	Change the operation mode to PU mode, and indicating lamp <b>PU</b>  will light up. Note: 1. When P.79=0, the inverter will first go into the external mode after the power is switched on or the inverter is reset. 2. For selecting and switching the operation mode, please refer to Section 4.1.
2	Enter the frequency setting mode and enter the target frequency into memory. Note: For detailed setting procedures, please refer to Section 4.1.4.
3	Press  or  to run the motor. At this point, indicating lamp <b>FWD</b>  or <b>REV</b>  will light up, indicating that the motor is running. The DU01 operation panel will automatically go into the monitoring mode and display the current output frequency. Note: 1. For detailed operation flow for the monitoring mode, please refer to Section 4.1.3. 2. While the motor is running, the user can enter the frequency setting mode to change the target frequency for regulating the motor speed.
4	Press  and the motor will begin to decelerate until it comes to a full stop. Indicating lamp <b>FWD</b>  or <b>REV</b>  will not turn off until the inverter stops the output voltage.

### 4.2.2 Basic operation procedures for external mode (P.79=0 or 2)

Step	Description
1	Change the operation mode to external mode, and indicating lamp <b>EXT</b>  will light up. Note: 1. When P.79=0, the inverter will first go into the external mode after the power is switched on or the inverter is reset. 2. When P.79=2, external mode will be the default for the inverter. 3. For selecting and switching the operation mode, please refer to Section 4.1.
2	If the target frequency is set by the input signal across terminal 4-5, please refer to <a href="#">P.39</a> in Chapter 5 If the target frequency is set by multi-speed stage levels, please refer to <a href="#">P.4</a> in Chapter 5. If the target frequency is set by the input signal across terminal 2-5, please refer to <a href="#">P.39</a> in Chapter 5. If the programmable operating mode is chosen, please refer to the multi-function terminals <a href="#">P.80~P.84</a> , <a href="#">P.86</a> , <a href="#">P.126~P.128</a> in Chapter 5.

Step	Description
3	<p>Turn on STF or STR to run the motor.</p> <p>At this point, indicating lamp <b>FWD</b> or <b>REV</b> will light up, indicating that the motor is running.</p> <p>Note: 1. For setting up the starting terminals STF and STR, please refer to <a href="#">P.78</a> and multi-function terminal <a href="#">P.80~P.84, P.86, P.126~P.128</a> in Chapter 5.            2. For detailed operation flow for the monitoring mode, please refer to Section <a href="#">4.1.4</a>.            3. If programmed operation mode is chosen, then STF and STR will be come the starting signal and the pause signal, respectively, instead of being the Run Forward or Run Reverse terminals.</p>
4	<p>Turn off STF or STR to decelerate the motor until it comes to a full stop.</p> <p>Indicating lamp <b>FWD</b> or <b>REV</b> will not turn off until the inverter stops the output voltage.</p>

### 4.2.3 Basic operation procedures for JOG mode (P.79=0 or 1)

Step	Description
1	<p>Change the operation mode to the JOG mode and indicating lamp <b>PU</b> will light up. At this point, the screen will display <b>u00</b> before the motor starts to run.</p> <p>Note: For selecting and switching the operation mode, please refer to Section <a href="#">4.1</a>.</p>
2	<p>Press <b>FWD</b> or <b>REV</b> to run the motor. At this point, indicating lamp <b>FWD</b> or <b>REV</b> will light up, indicating that the motor is running.</p> <p>Release <b>FWD</b> or <b>REV</b> to decelerate the motor until it comes to a full stop. Indicating lamp <b>FWD</b> or <b>REV</b> will not turn off until the inverter stops the output.</p> <p>Note: 1. For detailed operation flow for the monitoring mode, please refer to Section <a href="#">4.1.4</a>.            2. In the JOG mode, the target frequency is the value of <a href="#">P.15</a>, and the acceleration / deceleration time is the value of <a href="#">P.16</a>. Please refer to <a href="#">PR15</a> in Chapter 5.</p>

### 4.2.4 Basic operation procedures for communication mode (P.79=0 or 2)

In the communication mode, the user can set the parameters and run/stop or reset the inverters by communication. Please refer to [P.33](#) for details.

## 4.2.5 Basic operation procedures for combined mode 1 (P.79=4)

Step	Description
1	In Combined Mode 1, indicating lamp <b>PU</b> and <b>EXT</b> will light up. Note: For selecting and switching the operation mode, please refer to Section 4.1.
2	Enter the frequency setting mode and enter the target frequency into memory. Note: For detailed frequency setting procedures, please refer to Section 4.1.4.
3	Set the target frequency via DU01 operation panel and start the inverter by the external terminals. At this point, indicating lamp <b>FWD</b> or <b>REV</b> will light up, indicating that the motor is running. Note: For detailed operation flow for the monitoring mode, please refer to Section 4.1.4.
4	When the external terminals stop the output signals, the motor will decelerate until it comes to a full stop. Indicating lamp <b>FWD</b> or <b>REV</b> will not turn off until the inverter stops the output.

## 4.2.6 Basic operation procedures for combined mode 2 (P.79=5)

Step	Description
1	In Combined Mode 2, indicating lamp <b>PU</b> and <b>EXT</b> will light up. Note: For selecting and switching the operation mode, please refer to Section 4.1.
2	The target frequency is set by the external terminals: If the target frequency is set by the input signal across terminal 4-5, please refer to P.39 in Chapter 5. If the target frequency is set by multi-speed stage levels, please refer to P.4 in Chapter 5. If the target frequency is set by the input signal across terminal 2-5, please refer to P.39 in Chapter 5.
3	Press <b>FWD</b> or <b>REV</b> of DU01 operation panel to run the motor. At this point, indicating lamp <b>FWD</b> or <b>REV</b> will light up, indicating that the motor is running. Note: 1. For detailed operation flow for the monitoring mode, please refer to Section 4.1.4. 2. While the motor is running, the user can enter the frequency setting mode to change the target frequency for regulating the motor speed.
4	Press <b>STOP/RESET</b> and the motor will begin to decelerate until it comes to a full stop. Indicating lamp <b>FWD</b> or <b>REV</b> will not turn off until the inverter stops the output.

## 4.2.7 Basic operation procedures for combined mode 3 (P.79=6)

The target frequency is determined by communication. When RL, RM, RH and REX of multi-speed stage levels are “on”, the target frequency is determined by combination of multi-speed stage levels (Please refer to P.4~P.6, P.80~P.84, P.86, P.126~P.128). When external JOG is “on”, the target frequency is determined by P.15. Acceleration / deceleration time is set by the value of P.16. The inverter starting is activated by external terminals. The functions of P.996, P.998, and P.999 can be accomplished by communication.

## 4.2.8 Basic operation procedures for combined mode 4 (P.79=7)

The target frequency of the inverter is determined by the external terminals’ “external voltage signal”, “external current signal”, or “combination of multi-speed stage levels”. The inverter starting is activated by communication (including “Reset”).





## 4.2.9 Basic operation procedures for combined mode 5 (P.79=8)

The target frequency is determined by DU01 operating panel. When RL, RM, RH and REX of multi-speed stage levels are “on”, the target frequency is determined by combination of multi-speed stage levels (Please refer to P.4~P.6, P.80~P.84, P.86, P.126~P.128). When external JOG is “on”, the target frequency is determined by P.15. Acceleration / deceleration time is set by the value of P.16. The inverter starting is activated by the external forward and reverse terminals.

## 4.3 Operation





### 4.3.1 Pre-operation checks and preparation

Before starting the operation, the following shall be examined:

1. Check if the wiring is correct. Check especially the ac motor driver output terminals (**U/T1**, **V/T2**, **W/T3**), which cannot be connected to the power. Confirm that grounding terminal  is well grounded.
2. Check if there is a short circuit at the terminals or charged exposure.
3. Verify all terminal connections, and check if plug connectors (optional) and screws are all fastened.
4. Verify that no mechanical device is connected to the motor.
5. All switches must be disconnected before power on. Make sure that the inverter will not start and there is no abnormal activity when power on.
6. Turn on the power only after the cover is well placed.
7. Do not operate the switch with a wet hand.
8. Make sure of the following after power on:
  - (1). On the cover of machine, power indicating lamp  will light up but not alarm indicating lamp .
  - (2). On the DU01 operation panel, indicating lamp  Hz and **EXT**  will both light up.

### 4.3.2 Operation methods

For various operation methods, please refer to basic operation procedures in chapter 4 and parameter description in Chapter 5. Select the most appropriate operation methods according to the application requirements and regulations. The most commonly used operation methods are shown below:

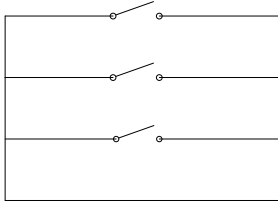
Operation method	Source of the target frequency	Source of the operating signal
DU01 operation panel operation	 or 	 or 
External terminal signal operation	 <p>RH    Parameter setting: RM    P.4=40 RL    P.5=30 SD    P.6=10</p>	Input by external terminals: STF-SD STR-SD
	2-5、4-5	





Note: RH, RM and RL mentioned in this section are function names of the “multi-function control terminal”. Please refer to P.80~P.84, P.86, P.126~P.128 for function selection and purposes of the multi-function control terminal. For related wiring, please refer to Section 3.5.

## 4.3.3 Trial run

Check cables and abnormalities before the trial run. After power on, the inverter is in the external mode.

1. After power on, make sure that the indicating lamp power  is on.
2. Connect a switch between STF and SD or STR and SD.
3. Connect a potentiometer between 2-5-10 or provide 0~5V dc between 2 and 5.
4. Adjust potentiometer or 0~5V dc to a minimum value (under 1V).
5. If STF is on, forward rotation is activated. If STR is on, reverse rotation is activated. Turn off STF or STR to decelerate the motor until it stops completely.
6. Check the following:
  - 1) Whether the direction of motor rotation is correct.
  - 2) Whether the rotation is smooth (check for any abnormal noise and vibration).
  - 3) Whether the acceleration / deceleration is smooth.

If there is an optional keyboard panel, do the following:

1. Make sure that the keyboard panel is connected to the inverter properly.
2. Change the operation mode to PU mode after power on, and the screen will display 50/60Hz.
3. Press  button to set the target frequency at about 5Hz.
4. Press  for forward rotation and  for reverse rotation. Press  to decelerate the motor until it stops completely.
5. Check the following:
  - 1). Whether the direction of motor rotation is correct.
  - 2). Whether the rotation is smooth (check for any abnormal noise and vibration).
  - 3). Whether the acceleration / deceleration is smooth.

If no abnormal condition is found, continue the trial run by increasing the frequency and go through the above procedure. Put the machine into operation if no abnormal condition is found.

Note: Stop working immediately if abnormalities are found when running the inverter or the motor. Check for possible causes according to "fault diagnosis". After inverter output is stopped and the power terminals (R/L1, S/L2, and T/L3) of the main circuit are disconnected, electric shock may occur if one touches the inverter's output terminals (U/T1, V/T2, and W/T3). Even if the major loop power is cut off, there is still recharging voltage in the filter capacitors. As a result, discharge takes time. Once the major loop power is disconnected, wait for the power indicating lamp to go off before testing the intermediate dc loop with a dc voltage meter. Once the voltage is confirmed to be below the safe value, it is safe to touch the circuit inside the inverter.

## 5. Parameter Description

### 5.1 Torque Boost (P.0, P.46)

P.0 “Torque boost”

P.46 “The second torque boost”

Related parameters

P.3 “Base frequency”  
 P.19 “Base frequency voltage”  
 P.47 “The second base frequency”  
 P.80~P.84 ,P.86, P.126~P.128  
 “Multi-function terminals selection”

- For an inverter controlled by V/F mode, when the motor starts up, the starting torque is usually inadequate since the output voltage of the inverter is inadequate. In this case, the output voltage can be elevated by properly setting the torque boost (P.0), and thus a better starting torque can be acquired.

Parameter	Factory setting	Setting range	Remarks
0	3% (7.5kW or below)	0~30%	---
	2% (11kW~55kW)		
	1% (75kW or above)		
46	99999	0~30%, 99999	99999: Function invalid

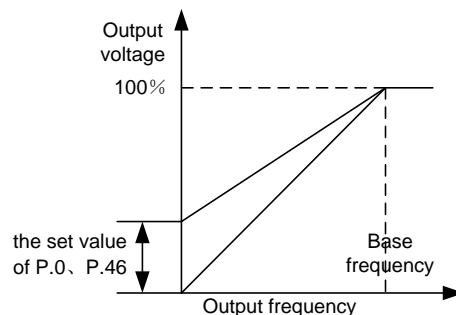

#### <Setting>

- If P.0=6% and P.19=220V, and when output frequency of the inverter is 0.2Hz, the output voltage is:

$$P.19 \times \left( \frac{100\% - P.0}{P.3} \times f + P.0 \right) = 220V \times \left( \frac{100\% - 6\%}{50Hz} \times 0.2Hz + 6\% \right) = 14.03V$$

- If RT is “on,” “The Second Torque Boost” on P.46 is valid (Note 2).

Note: 1. If the set value of P.0 is too high, it will activate current inverter protection or the activation will be impeded.  
 2. The second function is valid on when P.44≠99999.  
 3. RT mentioned in this section is the function name of the “multi-function control terminal”. Please refer to P.80~P.84, P.86, P.126~P.128 for function selection and purposes of the multi-function control terminal. For related wiring, please refer to Section 3.5.

## 5.2 The Range of the Output Frequency (P.1, P.2 and P.18)

P.1 “Maximum frequency”

P.2 “Minimum frequency”

P.18 “High-speed maximum frequency”

Related parameters  
P.13 “Starting frequency”

- The upper and lower limits of the output frequency can be restricted.

Parameter	Factory setting	Setting range	Remarks
1	120Hz(55kW or below)	0~120Hz	---
	60Hz(75kW or above)		
2	0Hz	0~120Hz	---
18	120Hz	120~400Hz	---

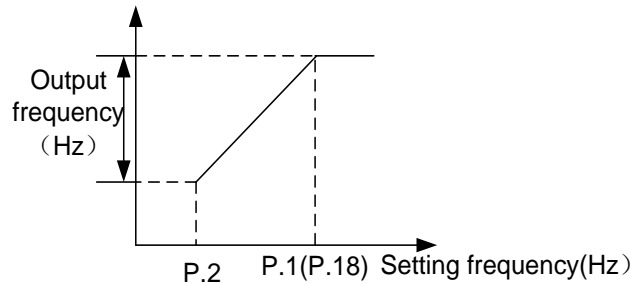

### <Setting>

- If the target frequency  $\leq P.2$ , the steady output frequency equals to P.2.
- If  $P.2 < \text{target frequency} \leq P.1$  (P.18), the steady output frequency equals target frequency.
- If  $P.1$  (P.18)  $< \text{target frequency}$ , the steady output frequency equals P.1.

Note: 1. The “maximum frequency” and the “high-speed maximum frequency” are interrelated. If the target upper limit frequency is set below 120Hz, use P.1 as the maximum frequency (the setting range of P.1 is 0~120 Hz). If the target frequency limited to between 120~400 Hz, use P.18 as the maximum frequency (the setting range of P.18 is 120~400 Hz).

2. If  $P.1 < P.2$ , the steady output frequency will be clamped to P.1.

3. The set frequency value cannot exceed the value of P.1.

## 5.3 Base Frequency and Base Frequency Voltage (P.3, P.19 and P.47)

P.3 “Base frequency”

P.19 “Base frequency voltage”

P.47 “The second base frequency”

Related parameters

P.14 “Load pattern selection”  
P.80~P.84, P.86, P.126~P.128  
“Multi-function terminals selection”  
P.189 “Factory setting function”

- The maximal output voltage of the inverter is called “base frequency voltage”.
- If the output frequency is lower than the base frequency, the output voltage of the inverter will increase with output frequency. If the output frequency has reached the base frequency (P.3/P.47), the output voltage will just be equal to the base frequency voltage. If the output frequency exceeds the base frequency and increase continuously, the output voltage will be clamped to the base frequency voltage.

Parameter	Factory setting	Setting range	Remarks
3	50Hz	0~400Hz	P.189=1
	60Hz		P.189=0
19	99999	0~1000V, 99999	99999: Change according to the power source voltage
47	99999	0~400Hz, 99999	99999: Function invalid

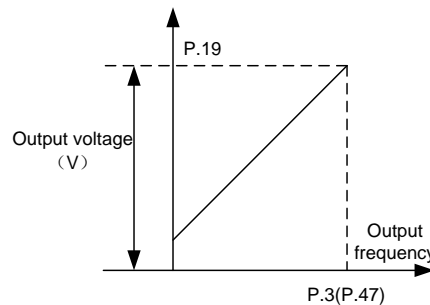

## <Setting>

- Use P.3 and P.47 to set up the base frequency.
- If RT is on, P.47 “The Second Base Frequency” is valid.(Note 1)
- Set up the base frequency voltage using P.19.(Note 2)

Note: 1. The second function is valid on when P.44≠99999.

2. If P.19=99999, the maximum output voltage of the inverter will depend on the value of the power supply voltage.

3. RT mentioned in this section is the function name of the “multi-function control terminal”. Please refer to P.80~P.84, P.86, P.126~P.128 for function selection and purposes of the multi-function control terminal. For related wiring, please refer to Section 3.5.

## 5.4 Multi-speed (P.4~P.6, P.24~P.27 and P.142~P.149)

P.4 “Speed 1 (high speed)”

P.5 “Speed 2 (medium speed)”

P.6 “Speed 3 (low speed)”

P.24~P.27 “speed 4 to 7”

P.142~P.149 “speed 8 to 15”

### Related parameters

- P.1 “Maximum frequency”
- P.2 “Minimum frequency”
- P.29 “Acceleration / deceleration curve selection”
- P.79 “Operation mode selection”
- P.80~P.84, P.86, P.126~P.128 “Multi-function terminals selection”

# Parameter Description

Parameter	Factory setting	Setting range	Remarks
4	60Hz	0~400Hz	---
5	30Hz	0~400Hz	---
6	10Hz	0~400Hz	---
24~27	99999	0~400Hz, 99999	99999: not selected
142	0Hz	0~400Hz, 99999	99999: not selected
143~149	99999	0~400Hz, 99999	99999: not selected

## <Setting>

- If all the set values of P.24~P.27 and P.142~P.149 are not 99999, “16-speed operation” is active. It means that with the combination of RL, RM, RH and REX, there are 16 speeds in total. For setting up the target frequency of the inverter, please refer to the figure below:

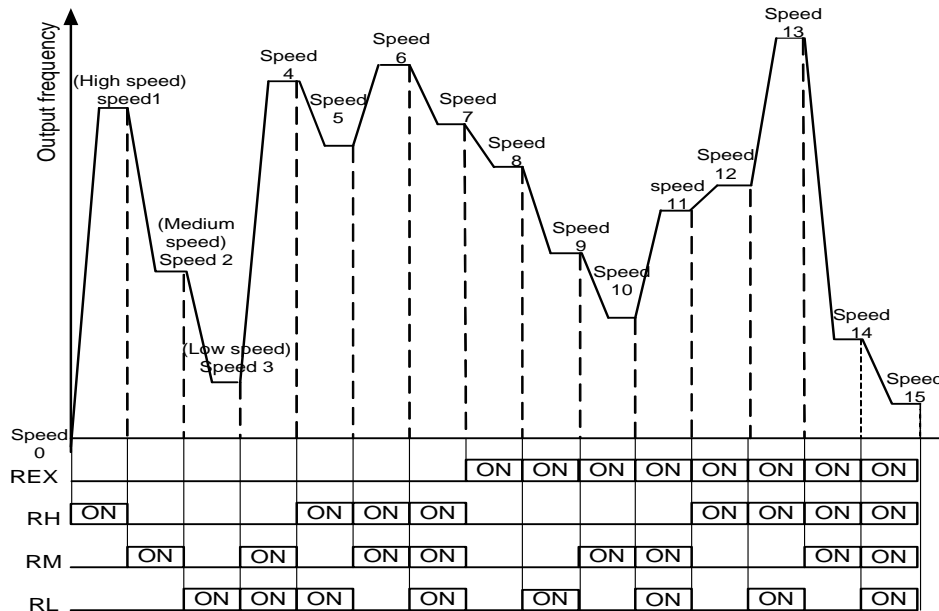

- Provided that the parameter set values of P.24~P.27 and P.142~P.149 are all 99999, the target frequency will be determined by RL, RM and RH these three speeds. See the table below (the priority of the terminals is RL>RM>RH):

Parameters	P.24=	P.25=	P.26=	P.27=	P.142=	P.143=	P.144=	P.145=	P.146=	P.147=	P.148=	P.149=
Target frequency	99999	99999	99999	99999	99999	99999	99999	99999	99999	99999	99999	99999
RL (P.6)	○	○		○	○	○		○		○		○
RM (P.5)			○				○				○	
RH (P.4)									○			

For example, When P.26=99999, the target frequency is determined by RM (the set value of P.5).

Note: 1. The multi-speed is only valid in the “external mode”, “combination mode 2” or “combined mode 4”.  
 2. RL, RM, RH, and REX mentioned in this section are the function names of the “multi-function control terminal”. (For example, when P.80=2, select the RL terminal to perform the RL (function). Please refer to P.80~P.84, P.86, P.126~P.128 for function selection and purposes of the multi-function control terminal. For related wiring, please refer to Section 3.5.

## **5.5 Acceleration / Deceleration Time (P.7, P.8, P.20, P.21, P.44 and P.45)**

P.7 “Acceleration time”

P.8 “Deceleration time”

P.20 “Acceleration / deceleration

reference frequency”

P.21 “Acceleration / deceleration time  
increments”

P.44 “The second acceleration time”

P.45 “The second deceleration time”

—Related parameters—

P. 3 “Base frequency”

P. 29 “Acceleration / deceleration curve selection”

P. 47 “The second base frequency”

P. 80~P. 84, P.86, P.126~P.128

“Multi-function terminal selection”

P. 189 “Factory setting function”

- When the output frequency of the inverter is accelerated from 0Hz to P.20 (P.3), the required time is defined as “acceleration time”.
- When the output frequency of the inverter is decelerated from 0Hz to P.20 (P.3), the required time is defined as “deceleration time”.

Parameter	Factory setting	Setting range	Remarks
7	20s	0~360s	P.21=0
		0~3600s	P.21=1
8	10s (7.5kW or below)	0~360s	P.21=0
	30s (11kW or above)	0~3600s	P.21=1
20	50Hz	1~400Hz	<u>P.189=1</u>
	60Hz		P.189=0
21	0	0, 1	0 The acceleration / deceleration time increments is 0.01s.
			1 The acceleration / deceleration time increments is 0.1s.
44,45	99999	0~360s	P.21=0
		0~3600s	P.21=1
		99999	Not selected

## <Setting>

- If P.21=0, minimum acceleration / deceleration time (P.7, P.8, P.16, P.44, P.45, P.111~P.118) increments is 0.01s.
- If P.21=1, minimum acceleration / deceleration time (P.7, P.8, P.16, P.44, P.45, P.111~P.118) increments is 0.1s.
- When RT is “on”, the second function is valid. For the operation characteristics of the motor, please refer to the second function.
- In this case, even though RT is “on”, the acceleration time is still the set value of P.7, the deceleration time is still the set value of PR8, the torque boost is still the set value of P.0, and the base frequency is still the set value of P.3.
- If P.44≠99999 and P.45=99999, when RT is “on”, the acceleration /deceleration time is the “set value of P.44”.
- If P.44≠99999, P.46=99999, when RT is “on”, the torque boost is the “set value of P.0”.  
If P.44≠99999 and P.46≠99999, when RT is “on”, the torque boost is the “set value of P.46”.
- If P.44≠99999, P.47=99999, when RT is “on”, the base frequency is the “set value of P.3”.  
If P.44≠99999 and P.47≠99999, when RT is “on”, the base frequency is the “set value of P.47.”

Note: RT mentioned in this section is the function name of the “multi-function control terminal”. Please refer to P.80~P.84, P.86, P.126~P.128 for function selection and purposes of the multi-function control terminal. For related wiring, please refer to Section 3.5.

## 5.6 Electronic Thermal Relay Capacity (P.9)

### P.9 “Electronic thermal relay capacity”

Related parameters  
P.80~P.84, P.86, P.126~P.128  
“Multi-function terminals selection”

- The “electronic thermal relay” uses the program of the inverter to simulate a thermal relay for preventing the motor from overheating.

Parameter	Factory setting	Setting range	Remarks
9	Rated current (Refer to appendix 1)	0~500A	---

## <Setting>

- Please set P.9 as the rated current of the motor at its rated frequency. The rated frequency of a squirrel-cage inductive motor made in different countries and areas is different. Please refer to the nameplate instruction on the motor.
- If P.9=0, the electronic thermal relay is disabled.
- In case the calculated heat by the electronic thermal relay exceeds the upper limit, an alarm will go off and the DU01 screen will display  $\overline{H}$ , and the output will be stopped.

Note: 1. After the inverter is reset; the thermal accumulating record of the electronic thermal relay will be reset to zero. Please pay attention in this area.

2. When two or more motors are connected to the inverter, they cannot be protected by the electronic thermal relay. Install an external thermal relay for each motor.

3. When a special motor is employed, the electronic thermal relay is no longer valid. Install an external thermal relay for each motor.

4. About wiring for an external thermal relay, please refer to P.80~P.84, P.86, P.126~P.128.

## 5.7 DC Injection Brake (P.10, P.11 and P.12)

### P.10 “DC injection brake operation frequency”

### P.11 “DC injection brake operation time”

### P.12 “DC injection brake operation voltage”

Parameter	Factory setting	Setting range	Remarks
10	3Hz	0~120Hz	---
11	0.5s	0~60s	---
12	4% (7.5kW or below)	0~30%	---
	2% (11kW~55kW)		
	1% (75kW or above)		

### <Setting>

- After a stop signal is put in (please refer to Chapter 4 for the primary operation of motor activation and stop), the output frequency of the inverter will decrease gradually. In case the output frequency reaches the “DC injection brake operation frequency (P.10),” the DC injection brake will be activated.
- During DC injection brake, a DC voltage will be injected into the motor windings by the inverter, which is used to lock the motor rotor. This voltage is called “DC injection brake operation voltage (P.12)”. The larger the P.12 is, the higher the DC brake voltage is, and the stronger the brake capability is.
- The DC brake operation will last a period (the set value of P.11) to overcome the motor inertia.

See the figure below:

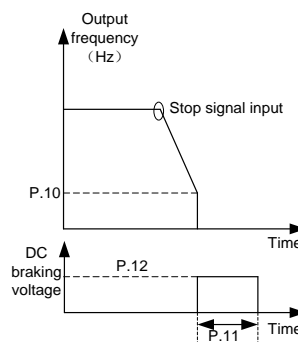

Note: To achieve the optimum control characteristics, P.11 and P.12 should be set properly.

## 5.8 Starting Frequency (P.13)

### P.13 “Starting frequency”

Related parameters  
P.2 “Minimum frequency”

- When the motor starts up, the instantaneous output frequency of the inverter is called “starting frequency”.

Parameter	Factory setting	Setting range	Remarks
13	0.5Hz	0~60Hz	---

#### <Setting>

- If the target frequency of the inverter is lower than the setting value of P.13, the motor will not run. When the signal of the motor starts, the output frequency will go up from the value of P.13.

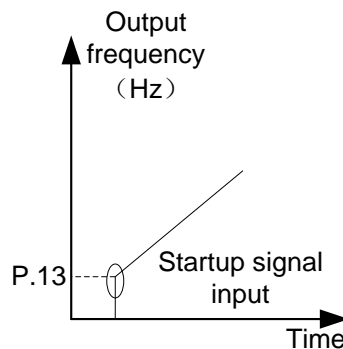

## 5.9 Load Pattern Selection (P.14, P.98~P.99, P.162~P.169)

P.14 “Load pattern selection”

P.98 “Middle frequency 1”

P.99 “Output voltage 1 of middle frequency”

P.162 “Middle frequency 2”

P.163 “Output voltage 2 of middle frequency”

P.164 “Middle frequency 3”

P.165 “Output voltage 3 of middle frequency”

P.166 “Middle frequency 4”

P.167 “Output voltage 4 of middle frequency”

P.168 “Middle frequency 5”

P.169 “Output voltage 5 of middle frequency”

Related parameters  
P. 0 “Torque boost”  
P. 46 “The second torque boost”  
P. 80~P. 84 ,P. 86  
“Multi-function terminals selection”

# Parameter Description

Parameter	Factory setting	Setting range	Remarks
14	0	0~13	P.14=4~13 are different VF curve options.
98	3Hz	0~400Hz	---
99	10%	0~100%	---
162	99999	0~400Hz, 99999	---
163	0%	0~100%	---
164	99999	0~400Hz, 99999	---
165	0%	0~100%	---
166	99999	0~400Hz, 99999	---
167	0%	0~100%	---
168	99999	0~400Hz, 99999	---
169	0%	0~100%	---

## <Setting>

- If P.14=4, suppose that P.19=220V, P.98=5Hz and P.99=10%, when the inverter is running at 5Hz, the output voltage equals  $P.19 \times P.99 = 220V \times 10\% = 22V$ .
- If RT is “on”, P.46 “The Second Torque Boost” is valid.

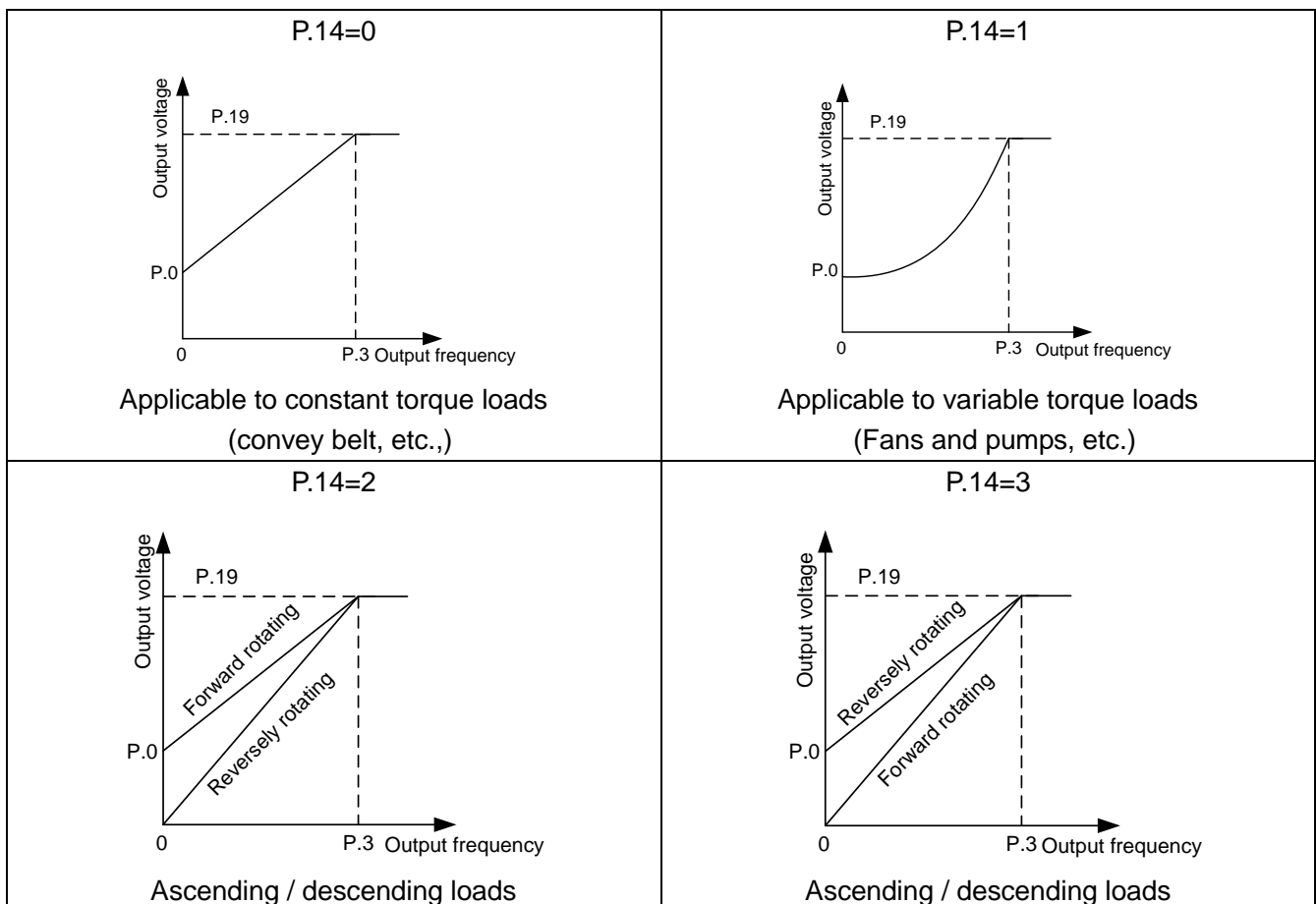

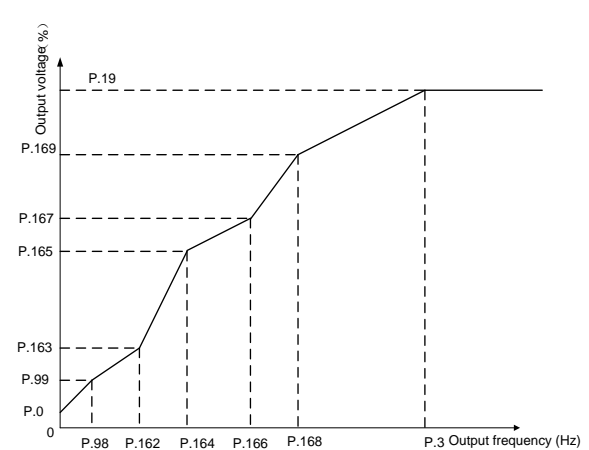
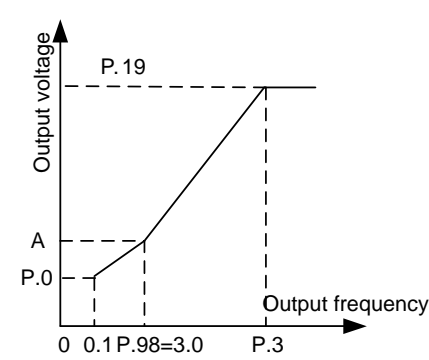
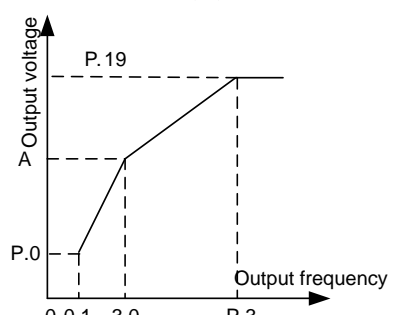
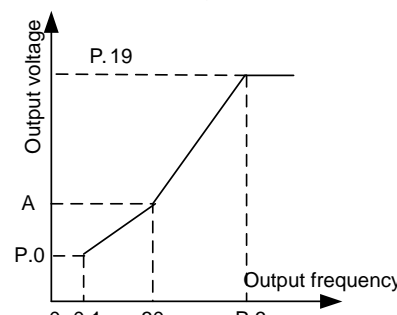
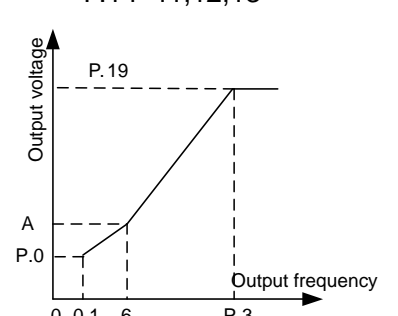
<p style="text-align: center;"><b>P.14=4</b></p>  <p>Whether it is high startup torque or descending torque, they are due to the set values (Note 1).</p>	<p style="text-align: center;"><b>P.14=5</b></p>  <p>When P.14 = 5, the value of A is 7.1% (Note 2).</p>
<p style="text-align: center;"><b>P.14=6,7,8</b></p>  <p>When P.14=6, the value of A is 8.7%.          When P.14=7, the value of A is 10.4%.          When P.14=8, the value of A is 12.0%.(Note 2)</p>	<p style="text-align: center;"><b>P.14=9,10</b></p>  <p>When P.14=9, the value of A is 20.0%.          When P.14=10, the value of A is 25.0%.(Note 2)</p>
<p style="text-align: center;"><b>P.14=11,12,13</b></p>  <p>When P.14 = 11, the value of A is 9.3%. When P.14 = 12, the value of A is 12.7%. When P.14 = 13, the value of A is 16.1%. (Note 2)</p>	

Note: 1. Referring to the diagrams above, set P.98 and P.99 if one point is needed. Set P.98, P.99, P.162 and P.163 if two points are needed. Set P.98, P.99, P.162, P.163, P.164 and P.165 if three points are needed.

2. If you set P.14 between 4 and 13, the curve will be invalid when P.0 is larger than the point A, where point A equals to P.0.

## 5.10 JOG Mode (P.15 and P.16)

P.15 “JOG frequency”

P.16 “JOG acceleration / deceleration time”

Related parameters  
 P.20 “Acceleration/deceleration reference frequency”  
 P.21 “Acceleration/deceleration time increments”

- In JOG mode, the output frequency is the set value of P.15, and the acceleration / deceleration time is the set value of P.15.

Parameter	Factory setting	Setting range	Remarks
15	5Hz	0~400Hz	---
16	0.5s	0~360s	<u>P.21=0</u>
		0~3600s	P.21=1

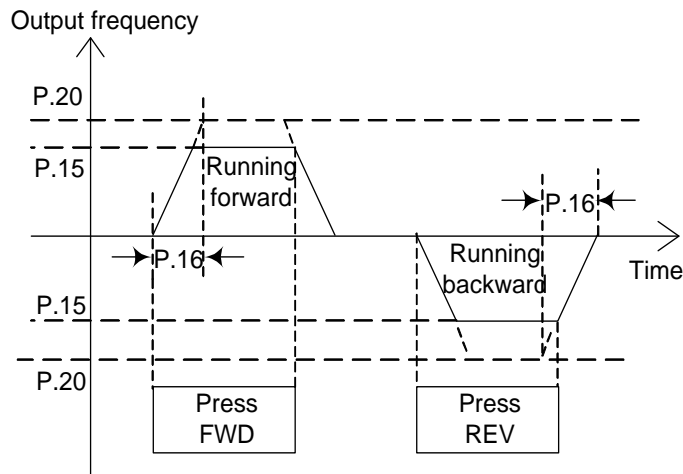

Note: Please refer to Section 4.1.1 for how to enter the JOG mode.

## 5.11 Stall Prevention (P.22, P.23 and P.66)

P.22 “Stall prevention operation level”

reduction starting frequency”

P.23 “Compensation factor at level reduction”

P.66 “Stall prevention operation

Related parameters  
 P.189 “Factory setting function”

# Parameter Description

- When the motor starts or target frequency is adjusted (increasing) under a heavy load, the motor speed is often unable to follow the output frequency closely. If the motor speed is lower than the output frequency, the output current will increase to improve the output torque. However, if the difference between the output frequency and the motor speed is too great, the motor torque will decrease, a phenomenon known as “stall”.

Parameter	Factory setting	Setting range	Remarks
22	120% ( Note 3 of Appendix 1)	0~400%	P.186=0
	150% ( Note 3 of Appendix 1)		P.186=1
23	99999	0~150%, 99999	When P.23=99999, stall prevention operation level is the set value of P.22.
66	50Hz	0~400Hz	P.189=1
	60Hz		P.189=0

## <Setting>

- During the time when a motor starts or the output frequency increases, the output current of the inverter will increase. Once the output current exceeds the curve in the diagram below, output frequency adjustment will be paused automatically until the motor attains the output frequency (at this moment, the output current of the inverter will decrease accordingly).

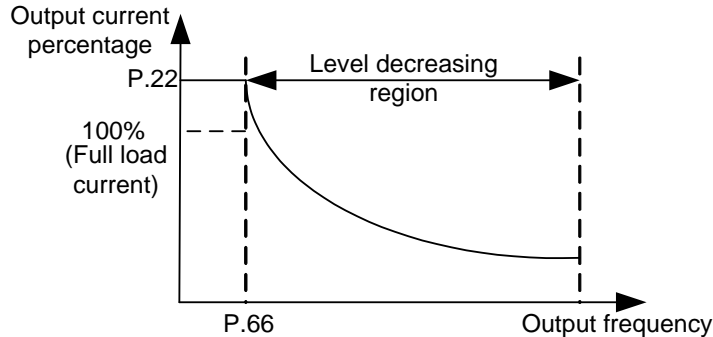

$$\text{Level percentage} = A + B \times \frac{P.22 - A}{P.22 - B} \times \frac{P.23 - 100}{100}$$

$$A = \frac{P.66 \times P.22A}{\text{Output frequency}} \quad B = \frac{P.66 \times P.22A}{400}$$

Note: When P.300=3 for sensorless vector control is selected from P.300 control method, P.22 will be used for the torque limited horizontal operation.

## 5.12 Output Frequency Filter Constant (P.28)

### P.28 “Output frequency filter constant”

- When the acceleration or deceleration time decreases and the output frequency switches from high-frequency to low-frequency, it may produce machine vibration which will affect product quality.
- When output frequency filtering constant P.28 is set, the inverter can filter out the output frequency to reduce machine vibration upon high-frequency and low-frequency is switched. The bigger the P.28 is, the better the filtering effect is. But the corresponding response delay will also increase. If P.28 is set to 0, the filtering function is invalid.

Parameter	Factory setting	Setting range	Remarks
28	0	0~31	---

## 5.13 Acceleration / Deceleration Pattern Selection (P.29)

### P.29 “Acceleration / deceleration curve selection”

Related parameters

- P. 3 “ Base frequency ”
- P. 7 “ Acceleration time ”
- P. 8 “ Deceleration time ”
- P. 20 “Acceleration / deceleration reference frequency”
- P. 44 “The second acceleration time”
- P. 45 “The second deceleration time”

Parameter	Factory setting	Setting range	Remarks
29	0	0~2	---

<Setting>

#### • When P.29=0, “linear acceleration /deceleration curve”

An acceleration slope is constructed by the combination of P.7 and P.20. A deceleration slope is constructed by the combination of P.7 and P.20.

When the target frequency varies, it increases with the “acceleration slope” or decreases with the “deceleration slope” linearly. See the figure below:

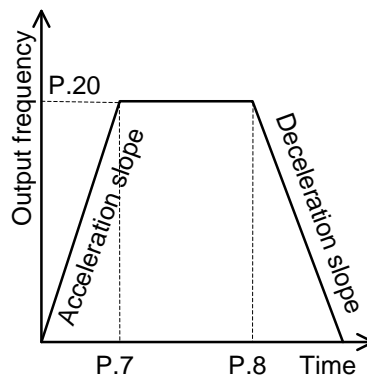

• **When P.29=1, “S pattern acceleration /deceleration curve 1”**

An acceleration slope is constructed by the combination of P.7 and P.20. A deceleration slope is constructed by the combination of P.7 and P.3.

The acceleration / deceleration curve has an S-shape change according to the “acceleration / deceleration slope”. The S-shape equation between 0 and P.3 is:

$$f = [1 - \cos(\frac{90^\circ \times t}{P.7})] \times P.3$$

The S-shape equation of P.3 or above is:

$$t = \frac{4}{9} \times \frac{P.7}{(P.3)^2} \times f^2 + \frac{5}{9} \times P.7$$

t: time; f: output frequency

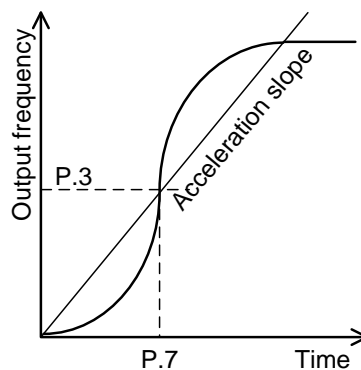

Note: This pattern is applicable to main shafts of the working machines.

• **When P.29=2, “S pattern acceleration /deceleration curve 2”**

An acceleration slope is formed by the combination of P.7 and P.20. A deceleration slope is formed by the combination of P.8 and P.20.

When the target frequency varies, the acceleration curve has an S-shape ascending according to the “acceleration slope”. The deceleration curve on the other hand has an S-shape deceleration according to the “deceleration slope”. As shown in the figure below, when the setting value of the inverter is adjusted from f0 to f2, an S-shape acceleration is undertaken once, and the time is P.7 x (f2-f0)/P.20. Then if the frequency is set from f2 to f3, a second S-shape acceleration is experienced, and the time is P.7 x (f3-f2) / P.20.

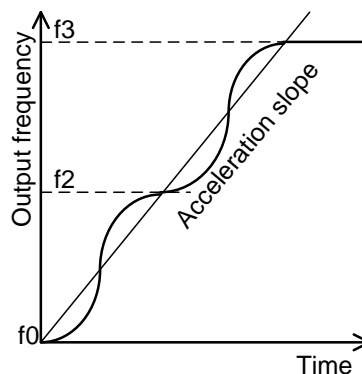

Note: this pattern can effectively reduce motor vibration during the acceleration / deceleration, and thus prevent the belts and gears from broken.

## 5.14 Regenerative Brake (P.30 and P.70)

### P. 30 “Regenerative brake function selection”

### P. 70 “Special regenerative brake duty”

- At the moment of the inverter output frequency switching from high to low, the rotation speed of the motor will be higher than the output frequency of the inverter due to load inertia, resulting in generator effect. This effect will cause a high voltage between the main-circuit terminals P and N, which will damage the inverter. Therefore, a proper brake resistor shall be mounted between terminals P and PR to dissipate the feedback energy.
- There is a built-in transistor inside the inverter. The conducting time ratio of the transistor is called “regenerative brake duty”. The higher the regenerative brake duty is, the more energy the brake resistor consumes, and the stronger the brake capability is.

Parameter	Factory setting	Setting range	Remarks	
30	0	0~1	0	If regenerative brake duty is fixed at 3%, parameter P.70 will be invalid.
			1	The regenerative brake duty is the set value of P.70.
70	0	0~30%		

Note: 1. In occasions where frequency starts or stops, a high capacity brake resistor is required.  
 2. Please refer to Section [3.7.3](#) for brake resistor selection.

## 5.15 Soft-PWM (P.31)

### P.31 “Soft-PWM selection”

- Soft-PWM is a control method that turns motor noises into pleasant complex tones.
- Motor noise modulation control is when the inverter varies its carrier frequency from time to time during the operation. The metal noises generated by the motor are not a single frequency. This function selection is to improve the high peak single frequency noises.
- This function is only valid under the V/F mode; i.e., it is effective when P.300=0.

Parameter	Factory setting	Setting range	Remarks
31	0	0	Soft-PWM invalid.
		1	Set Soft-PWM valid only when <a href="#">P.72</a> < 5

## 5.16 Communication Function (P.32, P.33, P.36, P.48~P.53, P.153 and P.154)

P.32 “Serial communication Baud rate selection”

P.36 “Inverter station number”

P. 49 “Stop bit length”

P.51 “CR & LF selection”

P.53 “Communication check time interval”

P.153 “Communication error handling”

P.33 “Communication protocol selection”

P.48 “Data length”

P.50 “Parity check selection”

P.52 “Number of communication retries”

P.154 “Modbus communication data format”

- When the communication parameters are revised, please reset the inverter. The SF-type inverters have two communication protocols for selection, namely, Shihlin protocol and Modbus protocol. Parameter P.32, P.36, P.52, P.55 and P.153 are suitable for both protocols. P.48~P.51 is only suitable for the Shihlin protocol, while P.154 is only suitable for the Modbus protocol. Please refer to communication protocols for more details.

Parameter	Factory setting	Setting range	Remarks	
32	1	0, 1, 2, 3	0	Baud rate: 4800bps
			1	Baud rate: 9600bps
			2	Baud rate: 19200bps
			3	Reserved
33	1	0, 1	0	Modbus protocol
			1	Shihlin protocol
36	0	0~254	(Note 1)	
48	0	0, 1	0	Data length: 8 bit
			1	Data length: 7 bit
49	0	0, 1	0	Stop bit length: 1 bit
			1	Stop bit length: 2 bit
50	0	0, 1, 2	0	No parity verification
			1	Odd
			2	Even
51	1	1, 2	1	CR only
			2	Both CR and LF
52	1	0~10	(Note 2)	

# Parameter Description

Parameter	Factory setting	Setting range	Remarks	
53	99999	0~999.8s, 99999	0~999.8	Use the set value for the communication overtime test
			99999	99999: No communication overtime test (Note 3)
153	0	0, 1	0	Warn and call to stop
			1	No warning and keep running
154	4	0~5	0	Protocol, 1, 7, N and 2 (Modbus, ASCII) (Note 4)
			1	1, 7, E, 1 (Modbus, ASCII)
			2	1, 7, O, 1 (Modbus, ASCII)
			3	1, 8, N, 2 (Modbus, RTU)
			4	1, 8, E, 1 (Modbus, RTU)
			5	1, 8, O, 1 (Modbus, RTU)

Note: 1. The number of inverters is practically determined by the wiring method and impedance matching. If Modbus protocol is used, please set the value to a nonzero value.  
 2. If the frequency of communication error exceeds the set value of P.52, and P.153 is set to 0, the alarm will go off and display OPT.  
 3. When P.53=99999, there is no time limit.  
 4. Modbus protocol. Displayed according to the starting bit, the data bit, parity check bit, and the stop bit. N: no parity check. E: 1-bit parity check. O: 1-bit odd parity check.

## 1. SF RS-485 Communication interface constituents and wiring

- SF RS-485 communication interface terminal arrangement

SF-RS485  
communications interface



Terminal name	Description
A	Inverter transceiver +
B	Inverter transceiver -
GND	Signal ground

- Communication between the position machine and single inverter (take computer as an example).

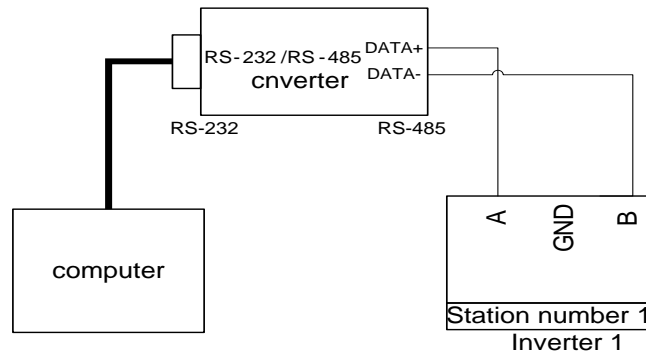

- Communication between the position machine and multiple inverters (take computer as an example).

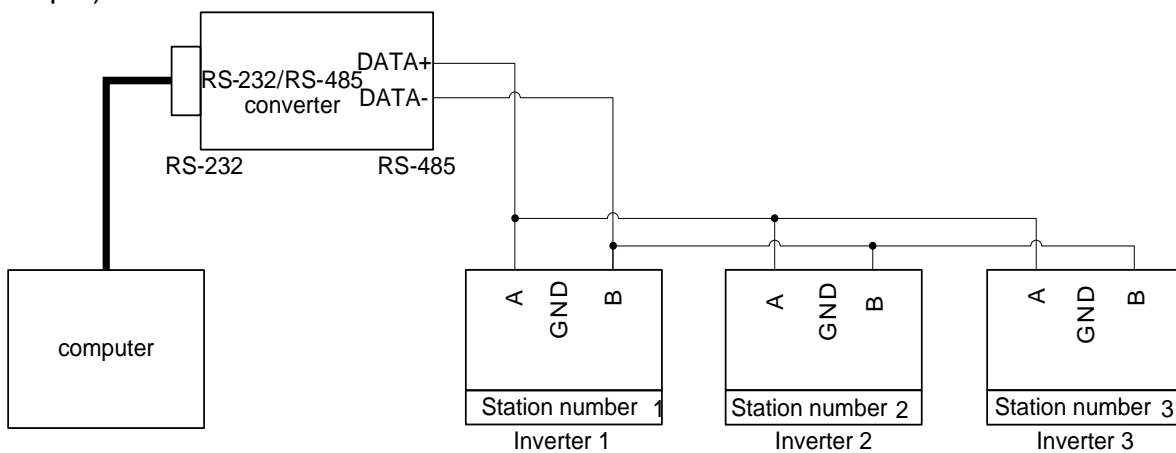

- SF series inverters have two types of communication protocols: Shihlin communication protocol and MODBUS communication protocol.

## 2. Shihlin communication protocol

- Automatically switch the position machine and the inverter to ASCII codes (hexadecimal) for communication.
- Please follow the following steps for data communication between the position machine and the inverter.

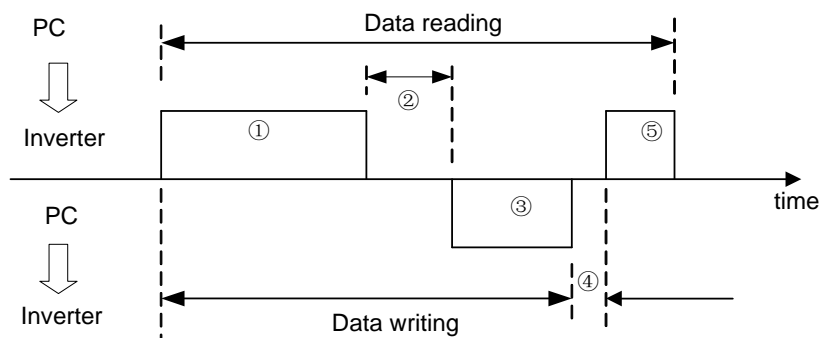

# Parameter Description

The above steps concerning communication actions and communication data format are explained below:

No.	Action content	Operation command	Frequency write-in	Parameter write-in	Inverter reset	Monitoring	Parameters Read-out	
①	Use the position machine's user procedure to send communication request to the inverter.	A	A	A	A	B	B	
②	Inverter data processing time	Yes	Yes	Yes	No	Yes	Yes	
③	Inverter's replay data (check data ① error)	No error (Accept the request)	(C)	(C)	(C)	No	E	E
		Error exists (Refuse the request)	D	D	D	No	D	D
④	Position machine's processing delay time	No	No	No	No	No	No	
⑤	Reply from the position machine regarding reply data ③ (Check data ③ error)	No error (No processing)	No	No	No	No	(C)	(C)
		Error exists (Output ③)	No	No	No	No	F	F

①. Data of the communication request sent by the position machine to the inverter.

Format	Data number													
	1	2	3	4	5	6	7	8	9	10	11	12	13	14
A (Data write-in)	ENQ *1)	Inverter station number		Command code		Waiting time	Data				Check code Sum check *7)		End symbol *3)	
B (Data read-out)	ENQ *1)	Inverter station number		Command code		Waiting time	Check code Sum check *7)		End symbol *3)					

# Parameter Description

## ③. Inverter reply data Data write-in

Format	Data number					
	1	2	3	4	5	6
(C) (No data error)	ACK *1)	Inverter station number		End symbol * 3)		
D (With data error)	NAK *1)	Inverter station number		Error code *5)	End symbol * 3)	

## Data read-out

Format	Data number												
	1	2	3	4	5	6	7	8	9	10	11	12	13
E (No data error)	STX *1)	Inverter station number		Data read-out				Unit *4)	ETX	Check code Sum check *7)		Check symbol *3)	
D (With data error)	NAK *1)	Inverter station number		Error code *5)	End symbol *3)								

## ⑤. Reply data from the position machine to the inverter during data read-out.

Format	Data number				
	1	2	3	4	5
(C) (No data error)	ACK *1)	Inverter station number		End symbol *3)	
F (With data error)	NAK *1)	Inverter station number		End symbol *3)	

### \*1). Control code

signal	ASCII Code	Content	signal	ASCII Code	Content
NUL	H00	NULL (Empty)	ACK	H06	Acknowledge (No data error)
STX	H02	Start of Text (Data begin)	LF	H0A	Line Feed (Change line)
ETX	H03	End of Text (Data end)	CR	H0D	Carriage Return
ENQ	H05	Enquiry (Communication request)	NAK	H15	Negative Acknowledge (Data errors)

\*2). Set the waiting time between 0 and 15 with a 10ms unit. Example: 5 → 50ms

\*3). End symbol (CR, LF codes)

When carrying out data communication from the position machine to the inverter, CR and LF codes at the end of the text are automatically set according to method of the position machine. At this time, the inverter has to be set according to the position machine, too. If only CR is selected, only one register will be occupied; if both CR and LF are selected, two registers will be occupied.

# Parameter Description

\*4). Unit: 0---> Unit 1, 1---> Unit 0.1, 2---> Unit 0.01, 3---> Unit 0.001。

\*5). Error code

Error code	Error item	Communication error and abnormality
H01	Error	The parity check of the data received by the inverter is different from the parity check set initially.
H02	Sum check Error	The Sum Check calculated by the inverter according to the received data is different from the received Sum Check.
H03	Communication protocol error	The syntax of the data received by the inverter has errors. The data is not completely received during the assigned period of time. CR and LF codes are different from the initial setting.
H04	Frame error	The stop bit of the data received by the inverter does not match to the stop bit set initially.
H05	Overflow error	When the inverter is receiving data, the position machine sends the next set of data before the inverter finishes receiving the current one.
H0A	Abnormal mode	The running inverter or the operation of the inverter disqualifies the requirements of the mode setting.
H0B	Command code error	The user assigns a command code that cannot be processed by the inverter.
H0C	Data range error	When setting the parameters and frequencies, the set values are outside the set range of the data.

\*6). When the parameter has the characteristics of 99999, the write-in or read-out of 99999 will be replaced by HFFFF.

\*7). Request the sum check code

The converted ASCII codes of the data are summed up in binary digit format. The lower bits (the lower eight bits) of the result (the sum) converted into ASCII binary digits (hexadecimal) are termed as the Sum Check Code.

● Communication example

*Example 1.* The position machine sends a forward rotation command to the inverter:

Step 1. Use the position machine to send a FA command in Format A:

ENQ	Inverter station number	Command code	Waiting time	Data	Check code	CR
	0	HFA		H0002	Sum check	
H05	H30 H30	H46 H41	H30	H30 H30 H30 H32	H44 H39	H0D

Sum Check calculation is:  $H30 + H30 + H46 + H41 + H30 + H30 + H30 + H30 + H32 = H1D9$ ; take the lower eight bits D9 to convert to ASCII code H44 and H39.

# Parameter Description

Step 2. After receiving and processing the data without error, the inverter will send a reply to the position machine in Format C:

ACK	Inverter station number 0	CR
H06	H30 H30	H0D

*Example 2.* The position machine sends a stop rotation command to the inverter:

Step 1. Use the position machine to send a FA command in Format A:

ENQ	Inverter station number 0	Command code HFA	Waiting time	Data H0000	Check code Sum check	CR
H05	H30 H30	H46 H41	H30	H30 H30 H30 H30	H44 H37	H0D

Step 2. After receiving and processing the data without error, the inverter will send a reply to the position machine in Format C:

ACK	Inverter station number 0	CR
H06	H30 H30	H0D

*Example 3.* The read-out value of the position machine P.195:

Step1. The position machine sends the write-in page break command to the inverter using Format A:

ENQ	Inverter station number 0	Command code HFF	Waiting time	Data H0001	Check code Sum check	CR
H05	H30 H30	H46 H46	H30	H30 H30 H30 H31	H44 H44	H0D

↓  
P.195 is on page 1.

Step 2. After receiving and processing the data without error, the inverter will send a reply to the position machine in Format C

ACK	Inverter station number 0	CR
H06	H30 H30	H0D

# Parameter Description

Step 3. The position machine requests the inverter for reading the value P.195 using Format B:

ENQ	Inverter station number 0	Command code H5F	Waiting time	Check code Sum check	CR
H05	H30 H30	H35 H46	H30	H30 H42	H0D



First 195 minus 100 equals to 95, then convert 95 to H5F hexadecimal digits. Next convert 5 and into H35 and H46, respectively, in ASCII code.

Step 4. Once the inverter receives and processes the data without error, the value of P.195 will be sent to the position machine in Format E:

STX	Inverter station number 0	Read-out data H1770(60Hz)	Unit	ETX	Check code Sum check	CR
H02	H30 H30	H31 H37 H37 H30	H32	H03	H36 H31	H0D

*Example 4.* Change the content of P.195 to 50 (the original factory setting is 60).

Step 1 to 2: Omitted (Same as Step 1 to 2 of Example 3);

Step 3: The position machine requests the inverter to write 50 in P.195 in Format A:

ENQ	Inverter station number 0	Command code HDF	Waiting time	Data H1388	Check code Sum check	CR
H05	H30 H30	H44 H46	H30	H31 H33 H38 H38	H45 H45	H0D



First, 195 minus 100 equals to 95;  
Concert 95 to H5F hexadecimal digits,  
H5F+H80=HDF



because the smallest unit of P.195 is 0.01,  
50 x 100 = 5000; then convert 5000 to hexadecimal  
digits H13888; Then covert 1, 3, 8 and 8 to ASCII  
codes for transmission.

Step 4. After receiving and processing the data without error, the inverter will send a reply to the position machine in Format C:

ACK	Inverter station number 0	CR
H06	H30 H30	H0D

# Parameter Description

Example 5. Write P.195 into 500 (this parameter range is set between 0 and 400)

Step 1 to 2: Omitted (same as Step 1 and 2 of Example 3);

Step 3: The position machine requests the inverter to write 500 in P.195 in Format A:

ENQ	Inverter station number 0	Command code HDF	Waiting time	Data HC350	SUM CHECK	CR
H05	H30 H30	H44 H46	H30	H43 H33 H35 H30	H46 H35	H0D

Step 4. After the inverter receives and processes the information, because the data exceed the set range of P.195, the data range is incorrect. The inverter will reply the error to the position machine in Format D:

NAK	Inverter station number 0	Error code H0C	CR
H15	H30 H30	H43	H0D

### 3. MODBUS communication protocol

1). Message format

- MODBUS serial transmission can be divided into two types: ASCII (American Standard Code for Information Interchange) and RTU (Remote Terminal Unit).

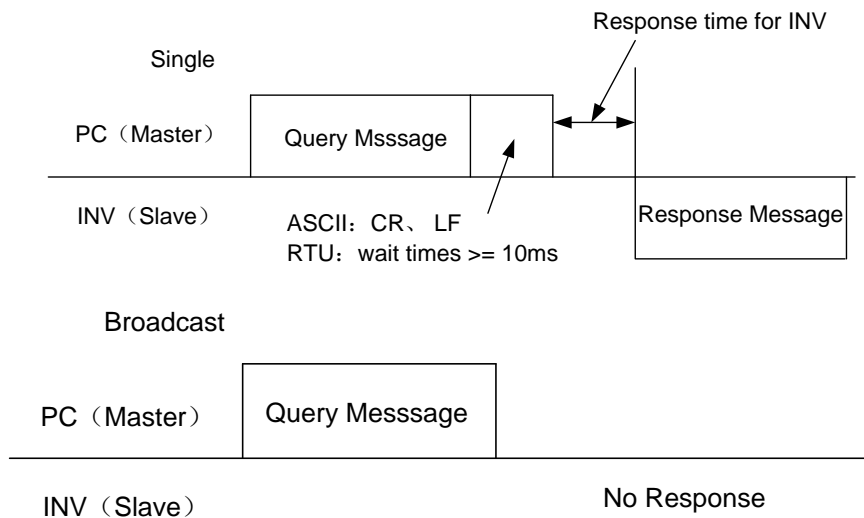

(1). Query

Position machine (main address) sends messages to the inverter of the assigned address (from the address).

(2). Normal response

After receiving the query from the Master, the Slave will execute the requested function and ask the Master to send the normal response.

(3). Error response

When receiving invalid function codes, address or data, the inverter will send the response to the Master.

# Parameter Description

## (4). Broadcast

The Master will assign the address 0, and the slave will send the message to all the Slaves. Once receiving a message from the Master, all the Slaves will execute the requested function without responding to the Master.

## 2). Communication format

- Basically, the Master will send Query Message to the inverter, which will send the response message to the Master. The address and function codes are duplicated for regular communication. Bit 7 of functional code during abnormal communication is positioned as “1” (=H80). The data bade is set to be the error code.
- Message constituents :

Format	Start	①Address	②Function	③Data	④Error check	Stop
ASCII	H3A	8 bits	8 bits	n×8 bits	2×8 bits	0D 0A
RTU	>=10ms					>=10ms

Message	Content												
①Address message set	<p>Set range: 0~254.0 is the broadcasting address; 1~254 are the equipment (inverter) address.</p> <p>The setup of <a href="#">P.36</a> is based on the equipment address. The set up is carried out when the main equipment sends messages to the equipments and when the equipment sends reply message to the main equipment.</p>												
②Function message set	<p>Only three functions have been done so far. The equipment carries out actions according to the request from the equipment. The main equipment sets functional codes excluded from the table below. The equipment returns error response. It is determined by the response from the equipment; regular function codes are the response for regular responses; H80 + function codes are the response for error responses.</p> <table border="1"> <thead> <tr> <th>Function name</th> <th>Function code</th> <th>Function description</th> </tr> </thead> <tbody> <tr> <td>Read multiple registers</td> <td>H03</td> <td>Read slave machine's continuous register content.</td> </tr> <tr> <td>Write single register</td> <td>H06</td> <td>Write data into slave machine's single register.</td> </tr> <tr> <td>Write multiple registers</td> <td>H10</td> <td>Write data into slave machine's multiple registers.</td> </tr> </tbody> </table>	Function name	Function code	Function description	Read multiple registers	H03	Read slave machine's continuous register content.	Write single register	H06	Write data into slave machine's single register.	Write multiple registers	H10	Write data into slave machine's multiple registers.
Function name	Function code	Function description											
Read multiple registers	H03	Read slave machine's continuous register content.											
Write single register	H06	Write data into slave machine's single register.											
Write multiple registers	H10	Write data into slave machine's multiple registers.											
③Data message set	Changes, including the starting address, the number of the write-in or read-out registers, and the write-in data, are made according to the function codes.												
④ Error check message set	ASCII is the check method for LRC, while RTU is the check method for CRC.(For more details concerning the verification calculation for LRC and CRC, please refer to Standard MODBUS Protocol specification.)												

# Parameter Description

ASCII mode's LRC check value calculation:

LRC check is simpler and it is used in the ASCII mode for checking the content of the message domain, excluding the colon at the beginning and the line change enter symbol at the end. It only sums up all the data to be transmitted according to the bite (not the ASCII code). If the result is greater than H100 of the hexadecimal digit, remove the exceeded part (e.g., if the result is H136 of the hexadecimal digit, then take H36 only) and add one.

RTU mode, CRC check value calculation:

1. Add one hexadecimal digit register. All the digits are 1.
2. Carry out XOR calculation for the higher bit of the hexadecimal digit register and the eight bits. The calculated result is entered to the hexadecimal digit register.
3. Shift this hexadecimal digit register one bit to the right.
4. If the right shifted bit (the marked bit) is 1, then polynomial 1010000000000001 and this register will carry out the XOR calculation. If the right shifted bit is 0, then it will return to 3.
5. Repeat 3 and 4 until 8 bits are shifted.
6. The other eight bits and the hexadecimal register carry out the XOR calculation.
7. Repeat 3~7 until all the bytes of the text carries out the XOR calculation with the hexadecimal register and was shifted for eight times.
8. The hexadecimal register content is the 2-byte CRC error checking, and it is added to the highest valid bit of the text.

When CRC is added to the message, lower bytes are added first, followed by the higher bytes.

● Communication format:

(1). Data read-out (H03)

Mode	Start	Address *1)	Function*2)	Start Address *3)	Number of register *4)	Check	Stop
ASCII	H3A	2char	2char	4char	4char	2char	0D 0A
RTU	>=10ms	1byte	1byte	2byte	2byte	2byte	>=10ms

Regular response

Mode	Start	Address *1)	Function *2)	Read-out data number *5)	Read-out data *6)	Check	Stop
ASCII	H3A	2char	2char	2char	...2N×1char	2char	0D 0A
RTU	>=10ms	1byte	1byte	1byte	...2N×1byte	2byte	>=10ms

Message	Content
1) Address	Set up the address for the to-be delivered message; 0 for invalid.
2) Function code	H03
3) Starting address	Set up the address of the register for reading the message.
4) Number of register	Set up the number of register for reading. Maximum number: 12.
5) Amount of data to be	Twice the amount of 4)
6) Data to-be read	Set the data for 4); the data will be read according to the descending sequence

# Parameter Description

## (2). Data write-in (H06)

Mode	Start	Address *1)	Function *2)	Start Address *3)	Write-in data *4)	Check	Stop
ASCII	H3A	2char	2char	4char	4char	2char	0D 0A
RTU	>=10ms	1byte	1byte	2byte	2byte	2byte	>=10ms

### Regular response

Mode	Start	Address *1)	Function *2)	Start Address *3)	Write-in data *4)	Check	Stop
ASCII	H3A	2char	2char	4char	4char	2char	0D 0A
RTU	>=10ms	1byte	1byte	2byte	2byte	2byte	>=10ms

Message	Content
1) Address	Set up the address for the to-be delivered message; 0 for invalid.
2) Function code	H06
3) Starting address	Set up the starting address of the register to be engaged in the write-in function.
4) Write-in data	Write the data in the assigned register. The data have to be 16bit (fixed).

Note: Regular response content and the inquired message are the same.

## (3). Write multiple registers (H10)

Mode	Start	Address *1)	Function *2)	Starting Address *3)	Number of register *4)	Data *5)	Write-in data *6)		Check	Stop
ASCII	H3A	2char	2char	4char	4char	2char	4char	...2N×1char	2char	0D 0A
RTU	>=10ms	1byte	1byte	2byte	2byte	1byte	2byte	...2N×1byte	2byte	>=10ms

### Regular response

Mode	Starting	Address *1)	Function *2)	Start Address *3)	Number of register *4)	Check	Stop
ASCII	H3A	2char	2char	4char	4char	2char	0D 0A
RTU	>=10ms	1byte	1byte	2byte	2byte	2byte	>=10ms

# Parameter Description

Message	Content
1) Address	Set up the address for the to-be delivered message; 0 for invalid.
2) Function code	H10
3) Starting address	Set up the starting address of the register to be engaged in the write-in function.
4) Number of register	Set up the number of register for reading. Maximum number: 12.
5) Amount of data	The range should be between 2 and 24. Set Twice the amount of *4).
Write-in data	Set the assigned data in *4), write the data according to the sequence of the Hi byte and the Lo byte and the data of the starting address: According to the order of the data of the starting address +1, data of the starting address +2..., etc.

## (4). Error response

Carry out error response according to the error in the function, address and data of the query message received by the equipment.

Mode	Starting	Address *1)	Function*2) H80+function	Error code * 3)	Check	Stop
ASCII	H3A	2char	2char	2char	2char	0D 0A
RTU	>=10ms	1byte	1byte	1byte	2byte	>=10ms

Message	Content
1) Address	Set up the address for the to-be delivered message; 0 for invalid.
2) Function code	The function code set for the main equipment + H80
3) Error code	Set the codes listed in the table below.

The list of error codes:

Source	Code	Meaning	Remarks
Slave reply	H01	Invalid function code	Set up function codes that cannot be handled by the equipment in the query message sent by the main equipment. Function codes that are not H03, H06, H08 and H10 (temporarily).
	H02	Invalid data address	Set up addresses that cannot be handled by the equipment in the query message sent by the main equipment (Asides from the addresses listed in the address table of the register; preserve the parameters, prohibit parameter reading, prohibit parameter writing).
	H03	Invalid data value	Set up data that cannot be handled by the equipment in the query message sent by the main equipment (parameters written outside the range, exist assigned mode, other errors, etc.).

Note: When performing multi-parameter reading, reading a preserved parameter is not a mistake.

Data sent to the main equipment will be tested by the inverter for the following mistakes, but the inverter will make no response for any detected error.

# Parameter Description

The list of the error test items:

Error item	Error content
Parity error	The parity test for data received by the inverter is different from the parity test set at the initial stage.
Frame error	The stop byte of the data received by the inverter mismatches the stop byte set at the initial stage.
Overflow error	When the inverter is receiving data, the position machine sends the next set of data before the inverter finishes receiving the current one.
Error test	The LRC/CRC calculated by the inverter according to the received data is different from the received LRC/CRC.

● Communication example

*Example 1.* The operation mode written by the communication is the CU (communication) mode.

Step 1: The position machine modifies the mode of the inverter.

Mode	Starting	Address	Function	Starting address		Write-in data		Check	Stop
ASCII	H3A	H30 H31	H30 H36	H31H30	H30 H30	H30 H30	H30 H30	H45 H39	0D 0A
RTU	>=10ms	01	06	10	00	00	00	8D 0A	>=10ms

Step 2. After receiving and processing the data without error, the inverter will send a reply to the position machine:

Mode	Starting	Address	Function	Starting address		Write-in data		Check	Stop
ASCII	H3A	H30 H31	H30 H36	H31H30	H30 H30	H30 H30	H30 H30	H45 H39	0D 0A
RTU	>=10ms	01	06	10	00	00	00	8D 0A	>=10ms

*Example 2.* Read the parameter P.195 value by the position machine

Step 1. The position machine sends message to the inverter for reading the value of P.195. The address of P.195 is H00C3.

Mode	Starting	Address	Function	Starting address		Number of registers		Check	Stop
ASCII	H3A	H30 H31	H30 H33	H30H30	H43 H33	H30 H30	H30 H31	H33 H38	0D 0A
RTU	>=10ms	01	03	00	C3	00	01	74 36	>=10ms

Step 2. Once the message is received and processed without mistake, the inverter will send the content of P.195 to the position machine.

Mode	Starting	Address	Function	Number of data read	Read-out data		Check	Stop
ASCII	H3A	H30 H31	H30 H33	H30 H32	H31 H37	H37 H30	H37 H33	0D 0A
RTU	>=10ms	01	03	02	17	70	B6 50	>=10ms

Because the decimal form of H1770 is 6000 and the unit of P.195 is 0.01, P.195 is 60 (6000 x 0.01 = 60).

# Parameter Description

*Example 3.* Change the content of P.195 to 50.

Step 1. The position machine sends message to the inverter for writing 50 into P.195.

Mode	Starting	Address	Function	Starting address		Write-in data		Check	Stop
ASCII	H3A	H30 H31	H30 H36	H30H30	H43 H33	H31 H33	H38 H38	H39 H42	0D 0A
RTU	>=10ms	01	06	00	C3	13	88	74 A0	>=10ms

Step 2. After receiving and processing the data without error, the inverter will send a reply to the position machine:

Mode	Starting	Address	Function	Starting address		Write-in data		Check	Stop
ASCII	H3A	H30 H31	H30 H36	H30H30	H43 H33	H31 H33	H38 H38	H39 H42	0D 0A
RTU	>=10ms	01	06	00	C3	13	88	74 A0	>=10ms

*Example 4.* Read the values of parameters P.0~P.11 by the position machine

Step 1. The position machine sends message to the inverter for reading the value of P.0~P.11. Starting address is H0000.

Mode	Starting	Address	Function	Starting address		Number of registers		Check	Stop
ASCII	H3A	H30 H31	H30 H33	H30H30	H30 H30	H30 H30	H30 H43	H46 H30	0D 0A
RTU	>=10ms	01	03	00	00	00	0C	45 CF	>=10ms

Step 2. After receiving and processing the data without error, the inverter will send a reply to the position machine:

Mode	Starting	Address	Function	Number of data read		Read-out data	Check	Stop
ASCII	H3A	H30 H31	H30 H33	H31 H38		...12×4 char	4char	0D 0A
RTU	>=10ms	01	03	18		...12×2 byte	2byte	>=10ms

*Example 5.* Rewrite the values of parameters P.0~P.11 by the inverter

Step 1. The position machine sends message to the inverter for writing the value of P.0~P.11.

Mode	Starting	Address	Function	Starting address		Number of registers		Data volume	Write-in data	Check	Stop
ASCII	H3A	H30 H31	H31 H30	H30 H30	H30 H30	H30 H30	H30 H43	H31 H38	...N×4 char	4char	0D 0A
RTU	>=10ms	01	10	00	00	00	0C	18	...N×2 byte	2byte	>=10ms

Step 2. After receiving and processing the data without error, the inverter will send a reply to the position machine:

Mode	Starting	Address	Function	Starting address		Number of registers		Check	Stop
ASCII	H3A	H30 H31	H31 H30	H30H30	H30 H30	H30 H30	H30 H43	H45 H33	0D 0A
RTU	>=10ms	01	10	00	00	00	0C	00 18	>=10ms

# Parameter Description

## 4. The list of communication commands

- The following commands and data are set for carrying out assorted operation control and monitoring.

Modbus Command code	Item	Shihlin protocol Command code	Data content and function description	Modbus address			
H03	Operation mode read-out	H7B	H0000: Communication mode; H0001: External mode; H0002: JOG Mode; H0003: Combination 1, combination 3 and combination 5 modes; H0004: Combination 2 and combination 4 modes	H1000			
H06/H10	Operation mode write-in	HFB					
H03	Inverter status monitoring	H7A	H0000~H00FF b8~b15: Preservation b7: Abnormality occurred b6: Frequency test b5: Ended by restoring the default value of the parameter b4: Overloaded b3: Reached the frequency b2: During reverse rotation b1: During forward rotation b0: During rotation	H1001			
H03	Monitoring	Frequency setup	H73	H0000~H9C40 ( Two decimal points when <u>P.37</u> =0; One decimal point when non-zero.)	H1002		
		Output frequency	H6F	H0000~H9C40 ( Same as above )	H1003		
		Output current	H70	H0000~HFFFF ( two decimal points )	H1004		
		Output voltage	H71	H0000~HFFFF ( two decimal points )	H1005		
		Abnormal content	H74	H0000~HFFFF: Abnormal codes from the last two times H0000~HFFFF: H74: Error code 1 and 2 b15                    b8 b7                    b0 <table border="1" style="width: 100%; border-collapse: collapse;"><tr><td style="width: 50%; text-align: center;">Error code 2</td><td style="width: 50%; text-align: center;">Error code 1</td></tr></table>	Error code 2	Error code 1	H1007
			Error code 2	Error code 1			
		H75	H75: Error code 3 and 4 b15                    b8 b7                    b0 <table border="1" style="width: 100%; border-collapse: collapse;"><tr><td style="width: 50%; text-align: center;">Error code 4</td><td style="width: 50%; text-align: center;">Error code 3</td></tr></table> For abnormal codes, please refer to the abnormal code list in the abnormal record parameter <u>P.288~P.291</u> .	Error code 4	Error code 3	H1008	
Error code 4	Error code 3						

# Parameter Description

Modbus Command code	Item		Shihlin protocol Command code	Data content and function description	Modbus address	
H06/H10	Target frequency write-in		HEE	H0000~H9C40	H1002	
H06/H10	Operation command write-in		HFA	H0000~HFFFF b8~b15: Preservation b7: Inverter emergency stop (MRS) b6: The second function (RT) b5: High speed (RH) b4: Medium speed (RM) b3: Low speed (RL) b2: Reverse rotation (STR) b1: Forward rotation (STF) b0: Preservation	H1001	
H06/H10	Inverter reset		HFD	H9696: <u>P.997</u> function When communicating with the position machine, resetting the inverter will cause the inverter to be incapable of sending data back to the position machine.	H1101	
H06/H10	Parameter delete		HFC	For details, please refer to the parameter restoration status table.	H5A5A	H1104
					H9966	H1103
					H9696	H1106
					H55AA	H1105
					HA5A5	H1102
H03	Parameter read-out		H00~H63	For <u>P.0</u> ~ <u>P.499</u> , the data range and the position of the decimal point, please refer to the parameter table. The MODBUS address of each parameter corresponds to the hexadecimal digit of the parameter number. For example, the MODBUS address of <u>P.138</u> is H008A.	H0000   H01F3	
H06/H10	Parameter write-in		H80~HE3			
---	Page change for parameter reading and writing	Read	H7F	H0000: P.0~P.99; H0001: P.100~P.199; H0002: P.200~P.299; H0003: P.300~P.399; H0004: P.400~P.499.	---	
		Write	HFF			

# Parameter Description

● Parameter restoration condition table

Data content	Parameter P operation	Communication Parameter P (Note)	<u>P.21, P.125, P.186, P.188~P.199, P.292, P.293, P.300~P.321</u> and communication parameter P excluded	Other P parameters	Error codes
H5A5A	<u>P.999</u>	o	o	x	x
H9966	<u>P.999</u>	o	o	o	x
H9696	Communication 999	x	o	x	x
H55AA	Communication 998	x	o	o	x
HA5A5	<u>P.999</u>	x	x	x	o

Note: Communication P parameters include P.32, P.33, P.36, P.48~P.53, P.79, P.153 and P.154.

## 5.17 Speed Display (P.37)

### P.37 “Speed display”

- In the “output frequency monitoring mode” of DUO1 operation panel, the screen will display the corresponding mechanical speed.

Parameter	Factory setting	Setting range	Remarks
37	0 r/min	0~5000r/min	0: Output frequency

#### <Setting>

- The set value of P.37 is the mechanical speed of the inverter when its output frequency is 60Hz.

For example: If the transmitting belt speed is 950 m/minute when the inverter output frequency is 60Hz, P.37 shall be set to 950. In the “output frequency monitoring mode” of DUO1 operation panel, the screen will display the speed of the transmitting belt.

Note: 1. There’s minute discrepancy between the displayed mechanical speed and the actual one.  
 2. Please refer to Section 4.1.2 for detailed operation of the “operation panel working mode.”  
 3. When the output mechanical speed is more than 9998, the screen will display 9999.

## 5.18 Voltage Signal Selection and Target Frequency

**(P.38, P.73, P.139, P.140 and P.141)**

P.38 “The maximum output frequency (the target frequency is set by the input signal across terminal 2-5)”

P.73 “Voltage signal selection”

P.139 “Voltage signal bias”

P.140 “Voltage signal gain”

P.141 “Voltage signal bias direction and rotational direction setup”

Related parameters

P. 79 “Operation mode selection”  
 P. 80 ~ P.84, P. 86, P.126~P.128  
 “Multi-function terminals selection”  
 P. 189 “Factory setting function”

- The set value of P.38 is the target frequency value of the inverter when the input signal of terminal 2-5 is 5V (10V).

Parameter	Factory setting	Setting range	Remarks
38	50Hz	1~400Hz	<u>P.189</u> =1
	60Hz		P.189=0
73	0	0, 1	0 The valid range of signal sampling (terminal 2-5) is 0~5V.
			1 The valid range of voltage signal sampling (terminal 2-5) is 0~10V.
139	0%	0~100%	---
140	100%	0.1~200%	---
141	0	0~11	---

### <Setting>

- P.141 is set by two digits, and each digit has the following meaning:

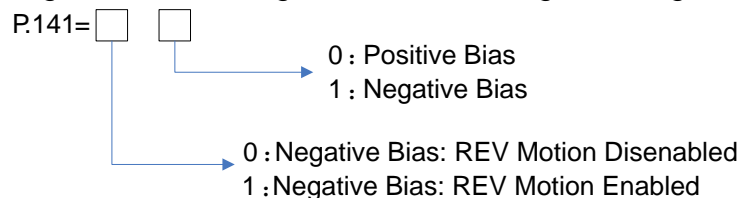

- The benefit of using the negative bias voltage for frequency setup is to prevent noise interference. Under a poor application environment, the user should avoid using signals below 1V for setting up the operation frequency of the inverter.
- The following examples illustrate impacts from voltage signals on rated frequency for each parameter setting.

Example 1: This example is the most commonly used method of adjustment. It is used when the inverter is in the “external mode”, “combined mode 2” or “combined mode 4”, and the frequency are set by terminal 2-5.

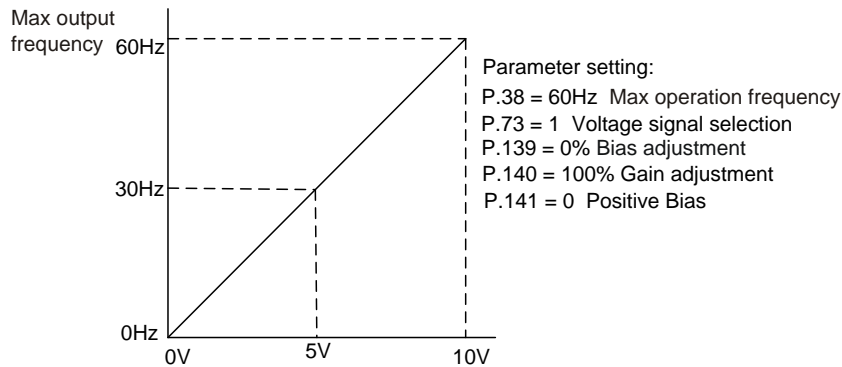

Example 2: This example is used by the industry for operating the ac motor drive. The goal is to have the set potentiometer equals to 10Hz when rotating to the far left. In other words, when activating, the lowest output of the ac motor drive has to be 10Hz. Other frequencies can be adjusted by the industry freely. It can be found from the figure below that the relationship between the output voltage and current signal and the set frequency has been changed from 0~10V corresponding to 0~60Hz to 0~8.33V corresponding to 10~60Hz. Therefore, the center of the potentiometer is 40Hz, and the latter zone of the potentiometer is consistently 60Hz. For the latter zone of the potentiometer to be operational, please refer to Example 3.

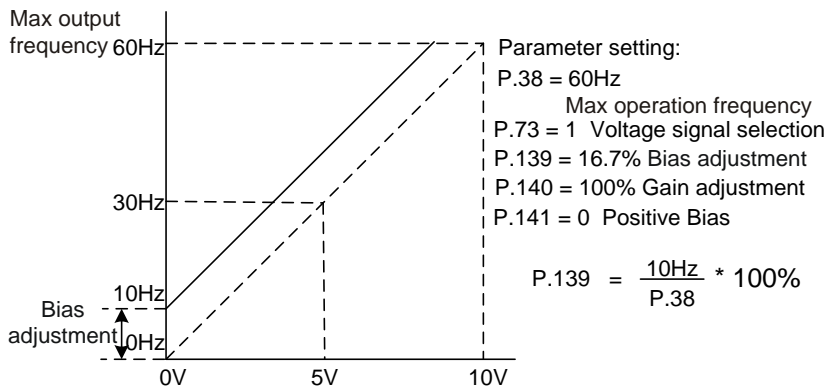

Example 3: This example is also frequently used by the industry. The comprehensive usage for all domain of the potentiometer setup elevates the flexibility.

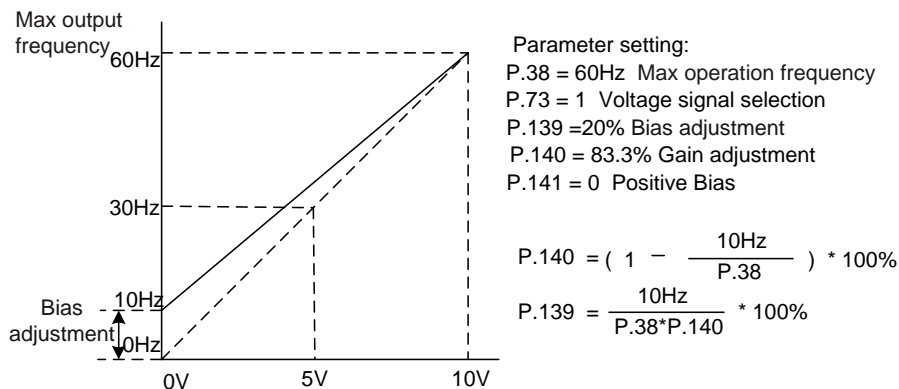

Example 4: This example uses 0~5V to set the frequency. Besides adjusting the method of gain, the user can also set P.38 to 120Hz or P.73 to zero to attain the same operation.

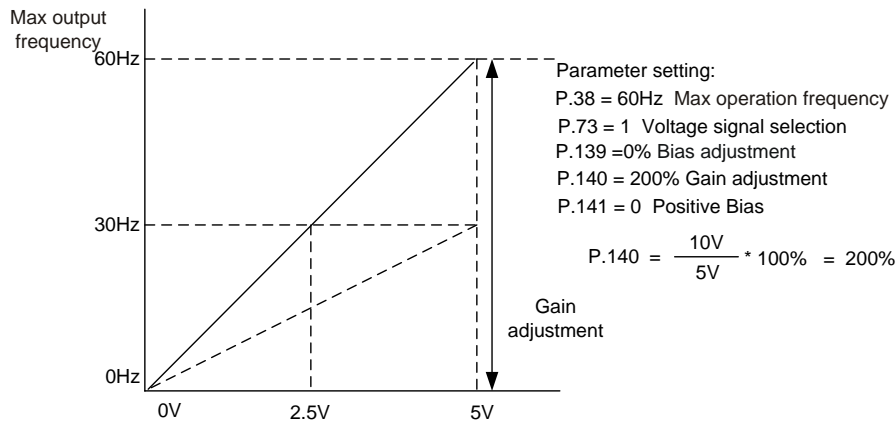

Example 5: This example is a typical negative bias application. An advantage of using negative bias is its anti-noise interference effect. Under an unfavorable application environment, it is recommended to avoid using a signal that is less than 1V to set up the operation frequency of the AC motor drive.

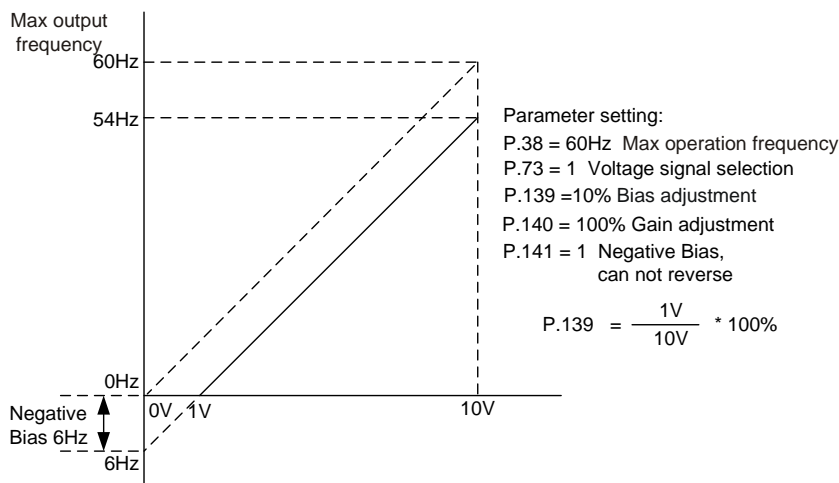

Example 6: This example is an extension of Example 5. The maximum operation frequency can be obtained by including the gain calibration. The wide application of this example offers the users good flexibility.

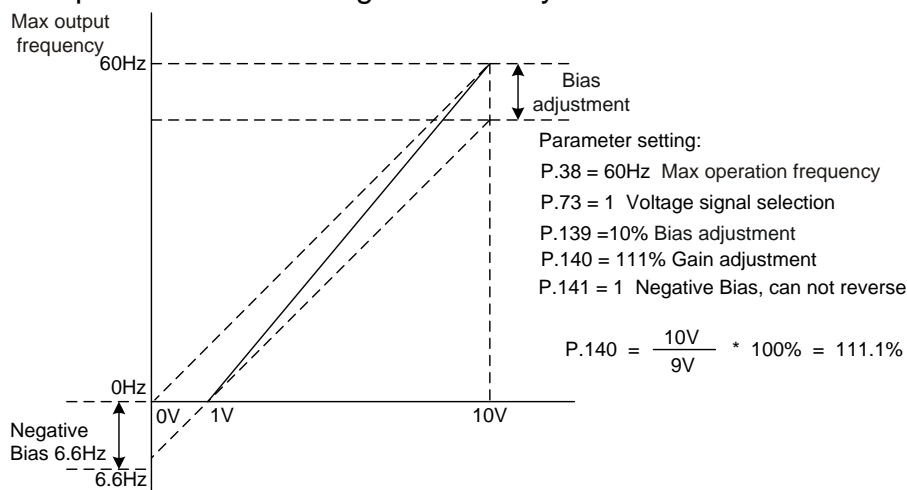

Example 7: This example integrates all the application of potentiometer. Together with the application of forward and reverse rotation, it fits in the system easily for assorted complicated application. Please be cautious that when setting up this application, the forward and reverse rotation commands of the external terminal will be disabled automatically.

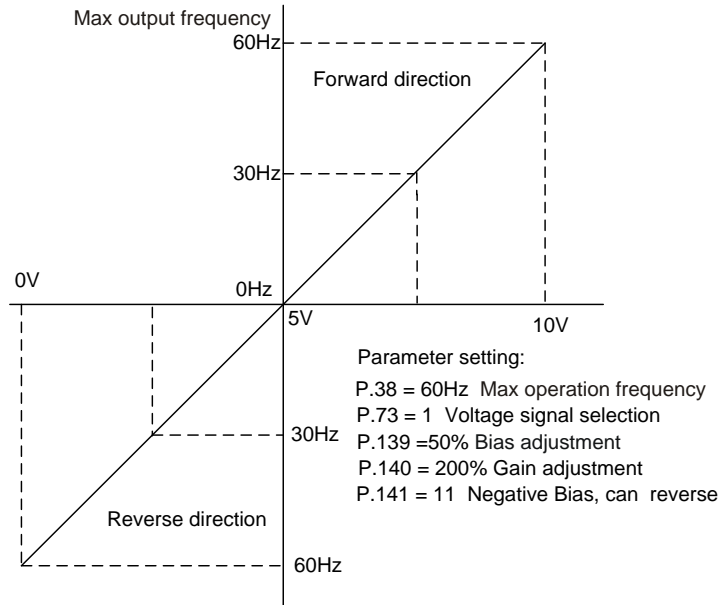

Example 8: This example is an application of negative slop setup. The industry often uses sensors for pressure, temperature or flow control. Some of the sensors output a 10V signal at high voltage or high flow. This signal acts as a command for the AC motor drive to decelerate or to stop. The setup presented in Example 8 can satisfy this type of application. Please be cautious that one limitation of this application is that the direction of rotation cannot be modified. For AC motor drive per se, only reverse rotation is possible.

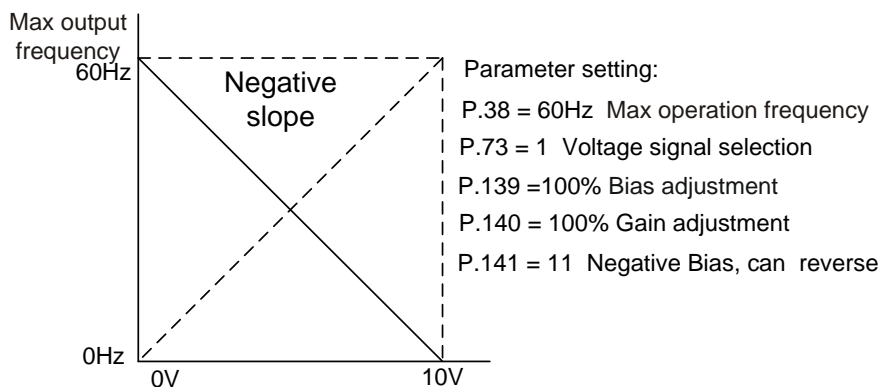

Note: 1. In “External mode”, “combined mode 2” or “combined mode 4”, the target frequency of the inverter will be determined by the signal between 2-5/4-5 terminal when RH, RM, RL and REX are all “off.”

2. RL, RM, RH, REX, AU, RT and RUN mentioned at the end of this section are the function names of “multi-function control terminal”. For the options and functions of multi-function control terminals, please refer to [P.80~P.84](#), [P.86](#), [P.126~P.128](#). For related wiring, please refer to Section [3.5](#).

## 5.19 The Input Signal across Terminal 4-5 and the Target Frequency

### (P.39)

P.39 “The maximum **operation** frequency (the target frequency is set by the input signal **of** terminal 4-5)”

- The set value of P.39 is the target frequency value of the inverter when the input signal of terminal 4-5 is 20mA (10V).

Parameter	Factory setting	Setting range	Remarks
39	50Hz	1~400Hz	P.189=1
	60Hz		P.189=0

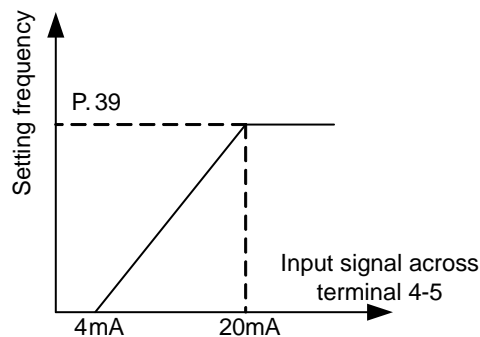

Note: 1. In “external mode”, “combined mode 2” or “combined mode 4”, if AU is “on”, target frequency of the inverter will be set by the input signal across terminal 4-5.

2. In “external mode”, “combined mode 2” or “combined mode 4”, if AU and either one of RH, RM, RL and REX are valid concurrently, multi-speed has higher priority.

3. RL, RM, RH, REX, AU, RT and RUN mentioned at the end of this section are the function names of “multi-function control terminal”. For the options and functions of multi-function control terminals, please refer to [P.80~P.84](#), [P.86](#), [P.126~P.128](#). For related wiring, please refer to Section [3.5](#).

## 5.20 Multi-function Output (P.40, P.85, P.129, P.130, P.120)

[P.40 “Multi-function output terminal SU function selection”](#)

[P.85 “Function selection for multi-function relay”](#)

[P.129 “Multi-function RUN output terminal pattern”](#)

[P.130 “Multi-function FU/10X output terminal pattern”](#)

[P.120 “Output signal delay time”](#)

# Parameter Description

Parameter	Factory setting	Setting range	Remarks		
40	1	0~15	0	RUN (Inverter running): Signals will be sent out when the output frequency is equal to or higher than the starting frequency.	
			1	SU (Reaching the output frequency): Signals will be sent out once the output frequency reaches the set frequency.	
			2	FU (Output frequency detection): It is the output signal when detecting the frequency exceeding the assigned frequency during the operation.	
85	5		3	OL (Overload detection): It is the output signal when the current limit function is triggered.	
			4	OMD (Zero current detection): If the current output percentage of the inverter is less than the set value of <u>P.62</u> and has exceeded <u>P.63</u> for a period of time, OMD will output the signal.	
			5	ALARM (Alarm detection): An alarm signal detected.	
129	0		6	PO1 (Section detection): In the programmed operation mode, the signal will be sent out at the end of each frequency operation.	
			7	PO2 (Periodical detection): In the programmed operation mode, the signal will be sent out at the end of each operation cycle.	
			8	PO3 (Pause detection): In the programmed operation mode, the signal will be sent out when the operation is suspended.	
130	2		9	BP (Inverter output): Switch between the inverter operation and the commercial power-supply operation function; in inverter operation, BP will send out signals.	
			10	GP (Commercial power-supply output): Switch between the inverter operation and the commercial power-supply operation function; in the commercial power-supply operation, GP will send out signals.	
			11	AUX (Aux output): If multimachine constant pressure system function selected, when the second water pump is operating, AUX will output signal.	
			12~15	Please refer to the manual for the fan's water pump multiple cards.	
120	0 s		0.1~3600s	---	

## <Setting>

- When P.120=0, the signal will be sent out directly when the set condition of P.40 (P.85) is met, the signal will be output directly.
- When P.120=0.1~3600, the signal will be sent out after the set time if the set condition of P.40 (P.85, P.129~P.130) is satisfied.

For example, FU (Output frequency detection) function (e.g., P.42/P.43=40Hz)

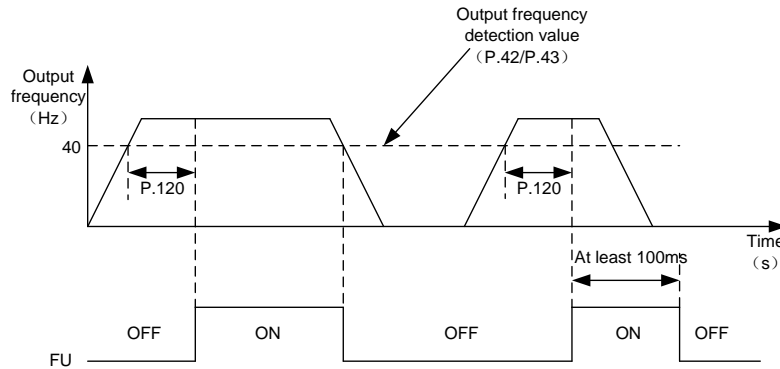

Note: 1. For the multi-function output terminal SU-SE, P.40=1 means the “SU” function. When changing the value of P.40, the corresponding function will change as shown in the above table.  
 2. The internal structures for multi-function output terminals SU, RUN and FU/10X are “open collector output.” Please refer to Section 3.5.6 and Section 3.5.7.  
 3. For multi-function relay A-B-C, the default set value of P.85 is 5 (i.e., the alarm function). When the value of P.85 is revised, its function will change respectively according to the function listed in the table above.

## 5.21 Up-to-frequency Sensitivity (P.41)

### P.41 “Up-to-frequency sensitivity”

Related parameters

- P. 40 “Multi-function output terminal SU function selection”
- P. 85 “Function selection for multi-function relay”
- P. 129 “Muti-function terminal RUN function selection”
- P. 130 “Multi-function terminal FU/10X function selection”

Parameter	Factory setting	Setting range	Remarks
41	10%	0~100%	---

## <Setting>

- If P.41=5%, SU will send out signals when the output frequency enters the “5% region near the target frequency”. For example, when the target frequency is set to 60Hz and P.41=5%, then if the output frequency is between  $60 \pm 60 \times 5\% = 57\text{Hz}$  and 63Hz, a SU signal will be sent out.

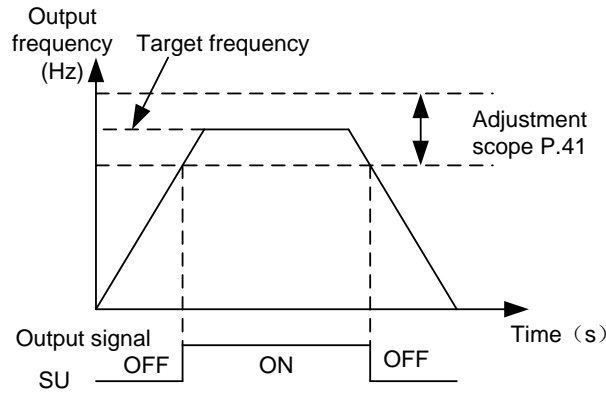

Note: In this paragraph, SU is the function name for “multi-function output terminal”. Please refer to [P.40](#), [P.85](#), [P.129](#) and [P.130](#). For wiring, please refer to Section [3.5](#).

## 5.22 Output Frequency Detection (P.42 and P.43)

[P.42](#) “Output frequency detection for forward rotation”

[P.43](#) “Output frequency detection for reverse rotation”

Related parameters

- P. 40 “Muti-function output terminal SU function selection”
- P. 85 “Function selection for multi-function relay”
- P. 129 “Muti-function terminal RUN function selection”
- P. 130 “Multi-function terminal FU/10X function selection”

Parameter	Factory setting	Setting range	Remarks
42	6Hz	0~400Hz	---
43	99999	0~400Hz, 99999	99999; same as P.42 setting

### <Setting>

- If P.42=30 and P.43=20, then FU/10X will send signals when the forward rotation output frequency exceeds 30Hz or when the reverse rotation output frequency exceeds 20Hz.
- If P.42=30 and P.43=99999 (factory default), then FU/10X will send out signals when the forward or reverse rotation output frequency exceeds 30Hz.

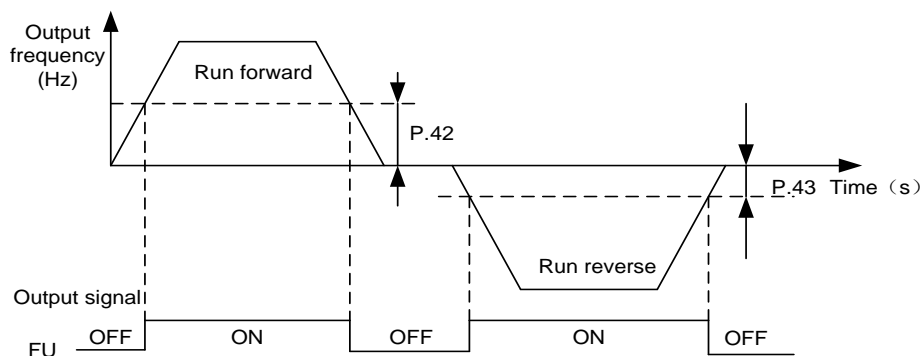

Note: In this paragraph, FU/10X is the function name for “multi-function output terminal”. Please refer to [P.40](#). For wiring, please refer to Section [3.5](#).

## 5.23 FM/AM Terminal (P.54~P.56, P.64, P.187, P.190 and P.191)

P.54 “FM/AM terminal function selection”

P.55 “Frequency display reference”

P.56 “Current monitoring reference”

P.64 “FM/AM output terminal selection (requires hardware switch SW1)”

P.187 “FM calibration parameter”

P.190 “AM output bias”

P.191 “AM output gain”

Related parameters









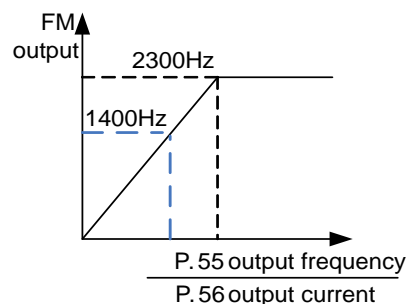
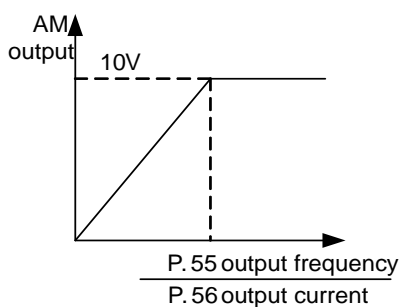

P. 89 “ Slip compensation coefficient ”  
 P.74 FU/10times frequency output terminal selection (requiring slot cover for switching)”

Parameter	Factory setting	Setting range	Remarks
54	0	0~4	---
55	50Hz	0~400Hz	P.189=1
	60Hz		P.189=0
56	Rated current	0~500A	---
64	0	0, 1	---
187	166	0~9998	---
190	0(Note 4 of Appendix 1)	0~1400	---
191	600(Note 4 of Appendix 1)	0~1400	---

### <Setting>

- When P.64=0, the function of external terminal FM/AM is AM function. A voltage between 0~10V can be output across terminal FM/AM and 5.
- When P.64=1, the function of external terminal FM/AM is FM function. The user can insert an electricity meter (current load: 1mA) between terminal FM/AM and SD to display the output frequency or the output currencty of the inverter.
- When P.54=0 and if the output frequency of the inverter is set as P.55, a voltage of 10V is produced at terminal FM/AM if AM terminal function is selected. If FM terminal function is selected, a pulse of 1440 Hz will be produced at terminal FM/AM.
- When P.54=1 and if the output frequency of the inverter is set as P.55, a voltage of 10V is produced at terminal FM/AM if the AM terminal function is selected. If FM terminal function is selected, a pulse of 1440 Hz is produced at terminal FM/AM.



- When P.54=2, the output corresponds to the busbar voltage value. If the voltage between P-N reaches the OV alarm level and the function of external terminal FM/AM is AM function, terminal FM/AM will output a voltage of 10V. If the function of external terminal FM/AM is FM function, terminal FM/AM will output a 1440Hz pulse.
- When P.54=3, the output corresponds to the accumulation rate of temperature increase of the inverter. If the temperature of the IGBT module of the inverter is too high and reaches the NTC level, the function of external terminal FM/AM will be AM function and a voltage of 10V will be sent out. If the function of external terminal FM/AM is FM function, terminal FM/AM will output a 1440Hz pulse.
- When P.54=4, the output corresponds to the electronic thermal rate. If either the electronic thermal relay (when P.9≠0) or the electronic thermal relay of the inverter's IGB module (when P.9=0) is running, the function of external terminal FM/AM will be AM function, and a voltage of 10V will be sent out. If the function of external terminal FM/AM is FM function, terminal FM/AM will output a 1440Hz pulse.
- AM terminal calibration procedures:
  1. Insert an electric meter with a full graduation of 10V across terminal FM/AM and terminal 5. Set P.64 and P.54 to 0. Calibrate the header due to accessory variation.
  2. Set P.13 to 0. Start the motor. Fix the output frequency of the inverter to 0 Hz.
  3. Read the set value of P.190, and the screen will display the output bias voltage of AM.
  4. Press  to adjust the value of P.190. The screen will display the accumulated output bias voltage of AM. Press  for more than 1 second, and the pointer will move upward. Press  to reduce the value of P.190, and the screen will display the progressively decreased output bias voltage of AM. Press  for more than 1 second, and the pointer will move downward. When the pointer is adjusted to 0, the calibration of AM output bias voltage is completed.
  5. Adjust and fix the output frequency of the inverter at 60 Hz.
  6. Read the set value of P.191, and the screen will display the current output gain of AM.
  7. Press  or  to adjust the output gain of AM. Press  for more than 1 second, and the pointer will move upward or downward. When the pointer moves to the full-scale position, the calibration is completed.
- FM terminal calibration procedures:
  1. Insert an electric meter with a full graduation of 1mA across terminal FM/AM and terminal SD, and set P.64 to 1 and P.54 to 0. Calibrate the header for accessory variation.
  2. Start the motor and fix the output frequency of the inverter to 60 Hz.
  3. When the motor runs steadily, read the set value of P.187. At this point, the screen will display the FM correction index. Press  to adjust the value of P.187. The screen will display a progressively increase of the FM correction index. Press  for more than 1 second, and the pointer will move upward. Press  to adjust the value of P.187 downward, and the screen will display a progressively decrease of the FM correction index. Press  for more than 1 second and the pointer will move downward.

# Parameter Description

Note: 1. Functions of FM and AM share a same terminal. Change the value of P.64 can change the function. SW1 on the control panel has to be switched off/on concurrently. The factory value is AM function.  
 2. When the value of P.74 is nonzero, FM and Am function will be invalid.

## 5.24 Restart Function (P.57, P.58, P.150 and P.160)

P.57 “Restart coasting time”

P.58 “Restart cushion time”

P.150 “Restart mode selection”

P.160 “Stall prevention operation level when restart”

Parameter	Factory setting	Setting range	Remarks
57	99999	0~30s, 99999	99999: No restart function
58	5s (7.5kW or below)	0~60s	---
	10s (11kW~55kW)		
	20s (75kW or above)		
150	0	0~221	---
160	100%	0~150%	Stall prevention operation level when restarting the machine

### <Setting>

- Once the driving power is interrupted while the motor is still running, voltage output will be stopped instantly. When the power is recovered and P.57=99999, the inverter will not restart automatically. When P.57=0.1~30, the motor will coast for a while (the set value of P.57) before the inverter restarts the motor automatically.
- Once the motor is restarted automatically, the output frequency of the inverter will be the target frequency, but the output voltage will be zero. Then the voltage will be increased gradually to the expected voltage value. The period for voltage increase is called “Restart cushion time (P.58)”.

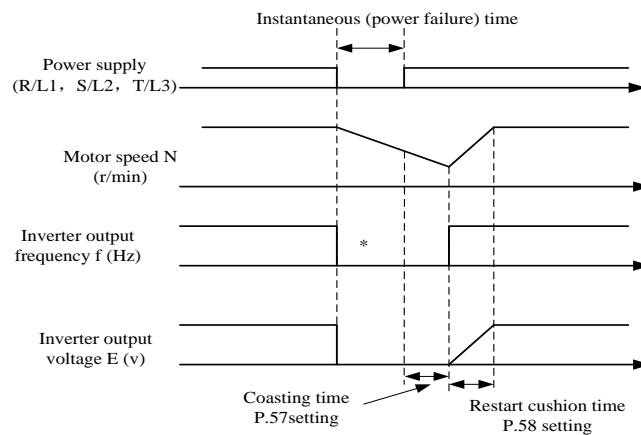

\* The output shut off timing differs according to the load condition

# Parameter Description

- There are four digits in P.150, and every digit has a different meaning and relevant position as following:

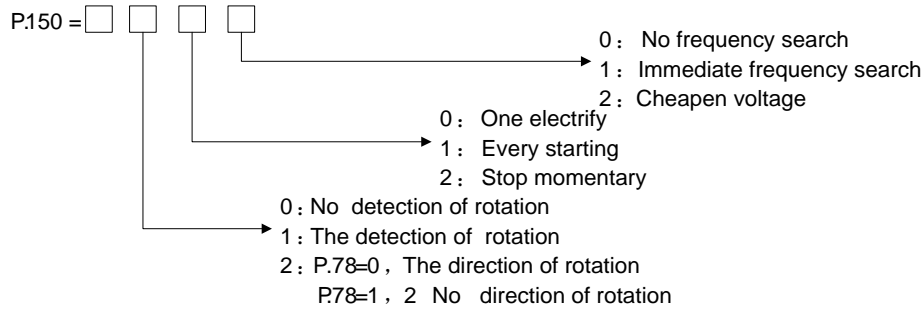

- Note:
1. When one needs an instant restart function, P.150 must be set.
  2. When P.150 is nonzero, linear acceleration / deceleration curve is the default.
  3. The direction detection position of P.150 is only valid for direct frequency search.
  4. This function is only valid under the V/F mode; i.e., it is effective when P.300=0.

## 5.25 Input Signal Filter Constant (P.60)

### P.60 “Input signal filter constant”

- When the running frequency is set by a voltage signal or a current signal, the voltage / current signal would be processed by an A/D converter. Due to the effect of device accuracy or noises, the external voltage signal or current signal may fluctuate, and cause a fluctuating operation frequency. This will make the output frequency unstable.
- The “Input signal filter constant setting P.60” is used to filter the fluctuation of the running frequency caused by the above factors. A larger P.60 set value can improve the filter performance yet delay the effect.

Parameter	Factory setting	Setting range	Remarks
60	31	0~31	---

## 5.26 Remote Setting Function (P.61)

### P.61 “Remote setting function selection”

Related parameters

- P. 1 “Maximum frequency”
- P. 7 “Acceleration time”
- P. 8 “Deceleration time”
- P. 18 “High-speed maximum frequency”
- P. 44 “The second acceleration time”
- P. 45 “The second deceleration time”

- If the operation box is located away from the control box, one can use contact signals to perform variable-speed operation without using analog signals under the external mode, PU mode, combined mode 1 and combined mode 4.

# Parameter Description

Parameter	Factory setting	Setting range	Remarks		
			Values	Remote setting function	Frequency setup storage function
61	0	0~3	0	No	---
			1	Yes	Yes
			2		No
			3		No(the remote setting frequency is cleared by STF/STR "turn off")

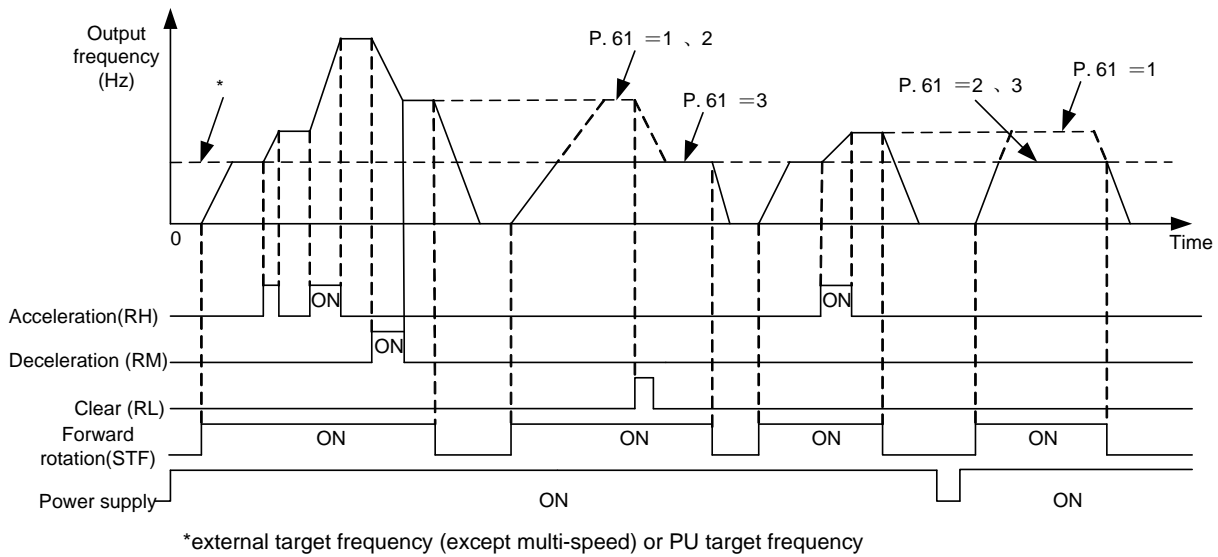

## <Setting>

### • Remote setting function

1. Whether the remote setting function is valid and whether the frequency setting storage function in the remote setting mode is used or not are determined by P.61.

Set P.61=1~3 (valid remote setting function), the function of terminal RM, RH and RL will be changed to acceleration (RH), deceleration (RM) and clear (RH). See the following figure:

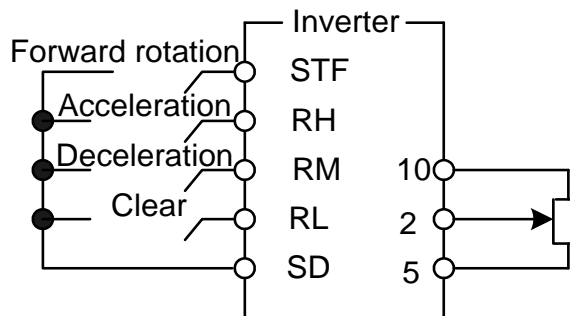

Wiring of the remote control setting

2. In the remote setting, the output frequency of the inverter is: (frequency set by RH/RM operation + external set frequency other than multi-speeds/PU set frequency)

- Frequency setting storage condition

The frequency setting storage function is to store the remote-set frequency (frequency set by RH/RM operation) in memory (EEPROM). Once the power supply is cut off and turned on again, the inverter can start running again at the remote-set frequency (P.61=1).

<Frequency setting storage condition>

- (1). It is the frequency when the start signal (STF/STR) is “off”.
- (2). When the signal RH (acceleration) and RM (deceleration) are both “off” and “on”, the remote-set frequency is stored every minute. (Current frequency set value and the last frequency set value are compared ever minute. If they are different, then the current frequency set value is written in the memory. If RL is on, write-in will unavailable).

Note: 1. The frequency can be varied by RH (acceleration) and RM (deceleration) between 0 and (the maximum frequency – frequency set by the main speed). The output frequency is limited by P.1.

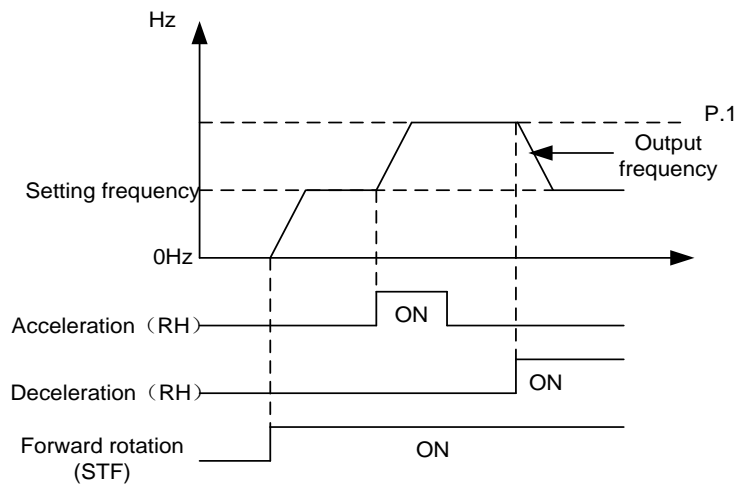

2. When the acceleration or deceleration signal is “on”, the acceleration / deceleration time will be determined by the set value of P.7 (the first acceleration time) and P.8 (the first deceleration time).
3. When RT signal is “on” and P.44≠99999 (the second acceleration time), P.45≠99999 (the second deceleration time), the acceleration / deceleration time will be determined by the set value of P.44 and P.45.
4. When the start signal (STF/STR) is “off” and RH (acceleration) / RM (deceleration) is “on”, the target frequency will also change.
5. When the start signal (STF/STR) becomes “off”, make the frequency setting storage function invalid (P.61=2, 3) if the frequency has to be changed continuously through RH/RM. If the frequency setting storage function is valid (P.61=1), the life of EEPROM will be shortened by frequent EEPROM data writing.
6. RH, RM and RL mentioned in this chapter are function names of “multi-function control terminal”. If the functions of the terminals are changed, other functions are likely to be affected. Please verify the functions of the terminals before changing the options and functions of the multi-function control panel (please refer to P.80~P.84, P.86, P.126~P.128). For wiring, please refer to Section 3.5.

## 5.27 Zero Current Detection (P.62 and P.63)

P.62 “Zero current detection level”

P.63 “Zero current detection time”

Related parameters

P. 40 “Multi-function output terminal SU function selection”  
 P. 85 “Function selection for multi-function relay”  
 P. 129 “Multi-function terminal RUN function selection”  
 P. 130 “Multi-function terminal FU/10X function selection”

Parameter	Factory setting	Setting range	Remarks
62	5%	0~200%, 99999	Function invalid
63	0.5s	0.05~1s, 99999	Function invalid

### <Setting>

- Assume the inverter's rated is full-loaded, the current is 20A, P.62=5% and P.63=0.5s, then when the output current is smaller than  $20 \times 5\% = 1A$  and exceeding 0.5s, OMD will send out signals.

See the figure below:

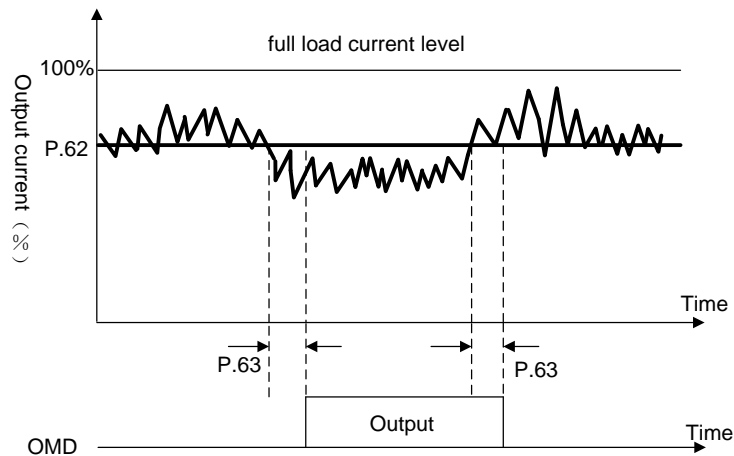

- If the set value of P.62 or P.63 is 99999, the zero current detection function is disabled.

Note: In this paragraph, OMD is the function name for “multi-function output terminal”. Please refer to [P.40](#). For wiring, please refer to Section [3.5](#).

## 5.28 Retry Function (P.65, P.67, P.68, P.69)

P.65 “Retry selection”

P.67 “Number of retries at alarm occurrence”

P.68 “Retry waiting time”

P.69 “Retry accumulation time at alarm”

- When an alarm goes off, a “retry” will take place to restore the previous setting.

# Parameter Description

- Inverter's retry is performed conditionally. When the alarm goes off and the inverter has an automatic retry, the re-occurrence of alarm going off before a set time is called a "continuous alarm". If continuous alarms happen for more than a set time, there is a significant malfunction. In this case, manual trouble shooting is necessary. The inverter at this point will perform no more the retry function. The number of Pre-defined occurrence is called "number of retries at abnormality (P.67)".
- If none of the alarm belongs to "continuous alarms", the inverter will perform retry for unlimited times.
- The period from the moment of alarm to that of retry is defined as "retry waiting time".

Parameter	Factory setting	Setting range	Remarks
65	0	0~4	---
67	0	0~10	---
68	1s	0~360s	---

## <Setting>

- When P.65=0, retry is invalid. When alarm occurs, the voltage output is stopped, and all the inverter functions are disabled.
- When P.65=1, in case of "over-voltage between P and N", the voltage output is stopped. After a period of waiting time (the set value of P.68), the inverter will perform the retry function.
- When P.65=2 and "over-current" occurs, voltage output is stopped. After a period of waiting time (the set value of P.68), the inverter will perform the retry.
- When P.65=3, in case of "over-voltage between P and N", the voltage output is stopped. After a period of waiting time (the set value of P.68), the inverter will perform the retry.
- When P.65=4, all the alarms have the retry function. When the alarm goes off, the voltage output will be stopped. After a period of waiting time (the set value of P.68), the inverter will perform the retry.
- When P.67=0, retry is invalid.
- When P.67≠0, given continuous alarm occurs for times within the set value of P.67, the inverter will perform the retry function. However, once the set value of P.67 is exceeded, the inverter will not perform the retry function.
- For each time a retry happens, the value of P.59 will be increased by one automatically. Therefore, the number of P.69 read from the memory indicates the number of retries that have occurred.
- If P.69 is rewritten with 0, the number of retry executed is cleared.

Note: The inverter will perform retry only after the retry waiting time of P.68. Therefore when using this function, please be aware of the possible danger when operating the inverter.

## 5.29 Brake Selection (P.71)

### P.71 “Idling braking and linear braking selection”

Parameter	Factory setting	Setting range	Remarks
71	1	0, 1	---

#### <Setting>

- P.71=0 is now idling braking. The inverter will terminate the output immediately after the stop sign is pressed, and the motor will be “racing”.
- P.71=1, it is now linear braking. The output of the inverter will follow the acceleration / deceleration curve after the stop sign is pressed.

## 5.30 Carrier Frequency (P.72)

### P.72 “Carrier frequency”

Parameter	Model	Factory setting	Setting range	Remarks
72	7.5kW or below	5kHz	0.7~10 kHz	---
	11~22kW	5kHz	0.7~9 kHz	
	30~90kW	4kHz	0.7~6 kHz	
	110~160kW	2kHz	0.7~6 kHz	

#### <Setting>

- The higher the carrier frequency, the lower the motor acoustic noise. Unfortunately, it will result in greater leakage current and larger noises generated by the inverter.
- The higher the carrier frequency, the more energy dissipated, and the higher the temperature of the inverter.
- In case of a mechanical resonance occurring in a system within the inverter, P.72 is helpful for improving the performance by adjusting its value.

Note: 1. The optimum carrier frequency shall be 8 times greater than the target frequency.  
 2. When the inverter is overheated and the carrier frequency is over 2kHz, the carrier frequency will be switched to 2kHz automatically.

## 5.31 FR/10X Frequency Output Terminal Selection (P.74)

### P.74 “Fu/10X frequency output terminal selection (requiring slot cover for switching)”

- The function of external terminal FU/10X is the multi-function output terminal or 10 times the output function.

Parameter	Factory setting	Setting range	Remarks	
74	0	0~10	0	Output function of terminal is determined by <a href="#">P.130</a> .
			1~10	Running frequency will Produce square wave impulse according to the value of P.74.

#### <Setting>

- When P.74=0, the function of external terminal FU/10X is the multi-function output terminal, and output function of terminal is determined by P.130 (please refer to [P.130](#)).
- When P.74=1~10, the function of external terminal FU/10X is 10 times the output function.
- When P.74=5 and temporary running frequency is at 20Hz, one can detect output impulse wave of terminal FU/10X and SE as follows:

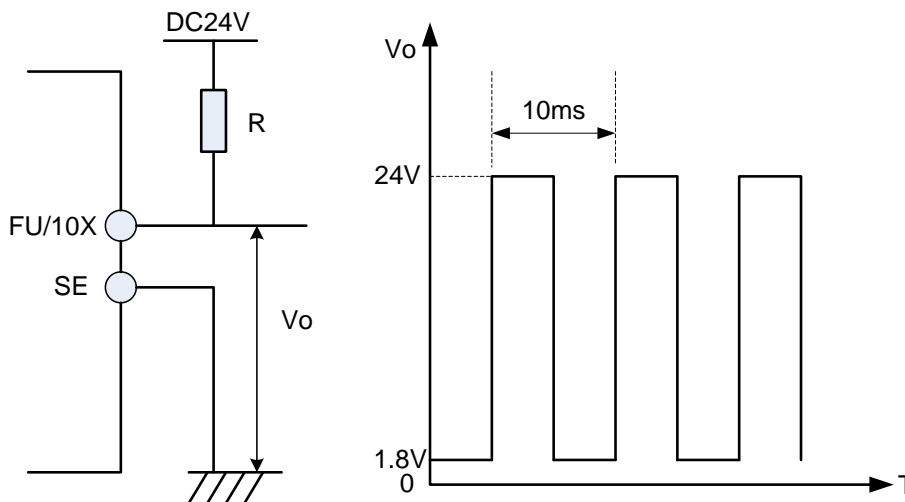



- Note: 1. Fu and 10X share the same hardware terminal. When switching the function (change the value of P.74), the pin slot on the control panel needs to be switched at the same time. The initial position of the slot cover is at FU.
2. When setting P.74 to non-zero and selecting the 10-fold frequency function, AM and FM functions will be invalid.
3. When P.74=1, the output will be 1-fold. The inverter can provide an output between 1 and 400 Hz with a 1% precision. The larger the rate of P.74, the larger the operation frequency, and the poorer the precision.
4. Resistor R must be greater than 330Ω, or terminal FU/10X may be damaged.

## 5.32 Stop or Reset Function Selection (P.75)

### P.75 “Stop or reset function selection”

Parameter	Factory setting	Setting range	Remarks
75	1	0, 1	---

#### <Setting>

- When P.75=0, it is only suitable for the PU and H2 mode (combined mode 2). Press  to stop the operation.
- When P.75=1, it is only suitable for the chosen mode. Press  to stop the motor.
- When the alarm goes off, press  for 1 second to reset the inverter.

Note: 1. In normal or abnormal condition reset the inverter by parameter P.997.

2. There are two built-in programs simulating the thermally-accumulating relay in the inverter, namely, the "electronic thermal relay" and "IGBT module thermal relay". After resetting the inverter, the values of the two relays of "electronic thermal relay" and "IGBT module thermal relay" will be set to zero.

3. In any modes except the PU and the H2 mode and when P.75=1, the motor can be stopped by pressing . The inverter then displays E0 and all functions of the inverter are disabled. To restart in the external mode, follow the procedures below:

Press  (The external STF/STR command will remove E0 to continue the operation). There is a start signal in the programmed operation mode. Once E0 is removed, the inverter will run at the section where it stopped after reset.)

4. To remove E0 in other modes, please turn the power off and on.

## 5.33 Parameters Write Protection (P.77)

### P.77 “Parameters write protection”

Parameter	Factory setting	Setting range	Remarks
77	0	0~2	---

#### <Setting>

- If P.77=0 and the motor stops, all parameters can be rewritten except P.188. When the motor is running, only P.4~P.6, P.24~P.27, P.54~P.56, P.77, P.131~P.138, P.142~P.149, P.161, P.187, P.190~P.199, P.215, P.216, P.223~P.225, P.230, P.232, P.288 and P.290.
- If P.77=1 and when the motor stops, only P.77 and P.79 can be rewritten. When the motor is running, parameter-writing is forbidden except P.77 and P.79.
- If P.77=2 and when the motor stops, all parameters can be written except P.188. When the motor is running, some parameters, including P.22, P.72, P.78, P.79, P.155, P.160, and P.188 cannot be written.

## 5.34 Forward/Reverse Rotation Prevention Selection (P.78)

### P.78 “Forward/reverse rotation prevention selection”

Parameter	Factory setting	Setting range	Remarks	
78	0	0~2	0	Forward rotation and reverse rotation are both permitted.
			1	Reverse rotation is prohibited (Press the reverse command to decelerate and stop the motor).
			2	Forward rotation is prohibited (Press the forward rotation command to decelerate and stop the motor).

## 5.35 Operation Mode Selection (P.79)

### P.79 “Operation mode selection”

Parameter	Factory setting	Setting range	Remarks	
79	0	0~8	0	“PU mode”, “external mode” and “Jog mode” are interchangeable.
			1	“PU mode” and “JOG mode” are interchangeable.
			2	“External mode” only
			3	“Communication mode” only
			4	“Combined mode 1” only
			5	“Combined mode 2” only
			6	“Combined mode 3” only
			7	“Combined mode 4” only
			8	“Combined mode 5” only

Please refer to Section [4.1](#) for details.

## 5.36 Multi-function Terminal Function Selection

**(P.80~P.84, P.86, P.126~P.128)**

P.80~P.84, P.86, P.126~P.128 “Multi-function terminal function selection”

Relevant Parameters	Corresponding terminal	Factory setting	Setting range	Value	Function name	Function description	Remarks
80	RL	2	0~39	0	STF	In “external mode”, “combined mode 1”, or “combined mode 3”, and when STF is on, the inverter runs forward.	In programmed operation mode, it is used as the start signal terminal.
				1	STR	In “external mode”, “combined mode 1”, or “combined mode 3”, and when STF is on, the inverter runs forward.	In programmed operation mode, it is used as the pause signal terminal.
				2	RL	Multi-speed	Please refer to <u>P.4~P.6</u> for multi-speed instruction.
				3	RM	Multi-speed	
81	RM	3	0~39	4	RH	Multi-speed	Refer to <u>P.39</u>
				5	AU	In “external mode”, “combined mode 2” or “combined mode 4”, the inverter target frequency is set by the signal input across terminal 4 -5.	
				6	OH	(Note 3)	
				7	MRS	When MRS is “turned on”, the output of the inverter will be terminated immediately.	
				8	RT	When RT is “on”, the characteristics are the same as the second function.	Refer to <u>P.44</u>

# Parameter Description

Relevant Parameters	Corresponding terminal	Factory setting	Setting range	Values	Function name	Function description	Remarks
82	RH	4	0~39	9	EXJ (External JOG)	In "external mode" and when EXJ is "on", the target frequency is set by <u>P.15</u> , and the acceleration / deceleration time is set by <u>P.16</u> .	
				10	STF+EXJ	Multiplexed function	
83	STF	0	0~39	11	STR+EXJ		The multiplexed function of the external terminal is the complex of several basic functions.
				12	STF+RT		
				13	STR+RT		
				14	STF+RL		
				15	STR+RL		
				16	STF+RM		
84	STR	1	0~39	17	STR+RM		
				18	STF+RH		
				19	STR+RH		
				20	STF+RL+RM		
				21	STR+RL+RM		
				22	STF+RT+RL		
86	RES	30	0~39	23	STR+RT+RL		
				24	STF+RT+RM		
				25	STR+RT+RM		
				26	STF+RT+RL+RM		
				27	STR+RT+RL+RM		
				28	RUN	In "external mode" and when Run is "on", the motor will have a forward rotation.	

# Parameter Description

Relevant Parameters	Corresponding terminal	Factory setting	Setting range	Values	Function name	Function description	Remarks
126	AU	5	0~39	29	STF/STR	In "external mode", it is used with RUN. The inverter has a reverse rotation when STF/STR is "on", but a forward rotation when STF/STR is "off".	Forward /reverse rotation control signal
				30	RES	External reset function	
				31	STOP	In "external mode", it can be used as a three-wire mode with the RUN signal or the STF-STR terminal (Note 4).	
				32	REX	Multi-speed set (16 levels)	
127	RT	8	0~39	33	PO	In "external mode" and when PO is "on", programmed operation mode is chosen (Note 5).	
				34	RES_E	When alarms occur, external reset become valid only when the alarm goes off.	
				35	MPO	In "external mode" and when MPO is "on", the manually operation cycle mode is chosen.	
				36	TRI	When TRI is on, triangle wave function is chosen.	

# Parameter Description

Relevant Parameters	Corresponding terminal	Factory setting	Setting range	Values	Function name	Function description	Remarks
128	MRS	7	0~39	37	GP_BP	Automatic switchover frequency between inverter and commercial power-supply operation.	
				38	CS	Manual switch to commercial power supply	
				39	STF/STR +STOP	The motor has a reverse rotation when the RUN signal is integrated into the external mode. Stop the motor and then run the motor for forward rotation.	

Note: 1. The default value are P.80=2(RL), P.81=3(RM), P.82=4(RH), P.83=0(STF), P.84=1(STR), P.86=30(RES), P.126=5(AU), P.127=8(RT) and P.128=7(MRS).

2. If the setting of P.80~P.84, P.86 and P.126~P.128 are changed, the functions of the terminals are modified too. For example, when P.80 is equal 2, the RL terminal is used for RL. When P.80 is changed to 8, than the RL terminal function will be changed to RT, i.e., the second function selection terminal. Take another example, if P.83 is equal to 0, the STF terminal will be STF forward rotation function. When P.83 is changed to 6, then STF terminal function will be changed OH, i.e., the external thermal relay terminal.

3. Wiring for the external thermal relay (OH): for the conventional motor wiring, the external thermal relay is often placed at the front of the motor to prevent the motor from overheating. The wiring configuration is shown on the right. When the external thermal relay is separated, the alarm of the inverter will be tripped off and "OHT" will be displayed on the screen.

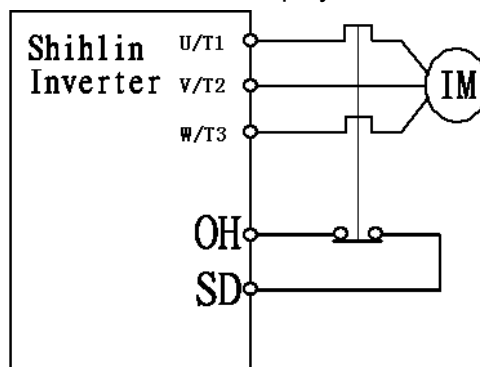

4. The operation of the inverter can be controlled by four means ("1" for terminal close, "0" for terminal open, and X = 0, 1, 2, 3, 4, 5, 6).

(1) Two-wire control mode 1:

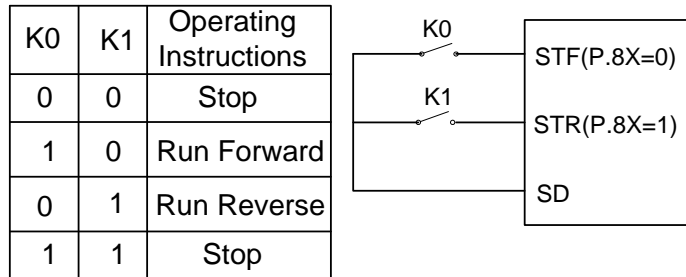

(2). Two-wire control mode 2:

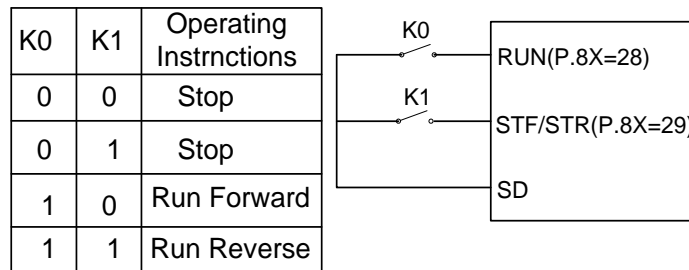

(3). Three-wire control mode 1 (with self-maintenance function): K0 is for the STOP function that is normally close. When it is open, the inverter will stop. K1 and K2 is the forward and reverse signals that are normally open. They indicate that pulse signal is active, i.e., jog is valid.

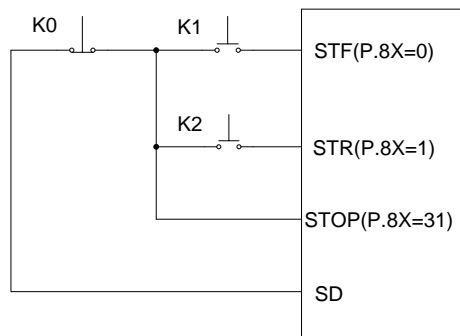

(4). Three-wire control mode 2 (with self-maintenance function): K1 is for the STOP function that is normally close. When it is open, the inverter will stop. K2 is the RUN signal that is normally open. It indicates that pulse signal is active, i.e., jog is valid. For the direction changing signal (STF/STR), the parameter corresponds to the external terminals is 39. When changing the direction, stop the inverter first, RUN the inverter before activating it.

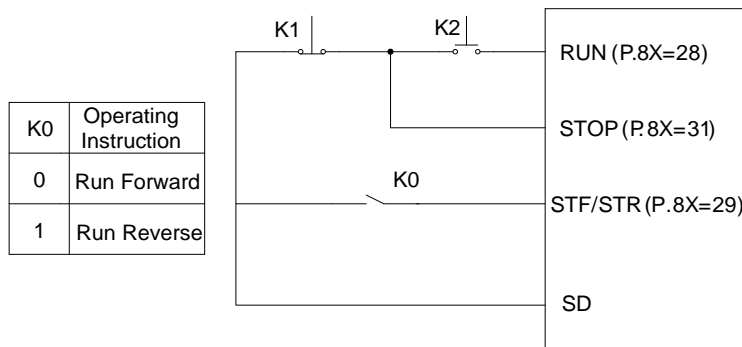

- (5). In “external mode” and when PO is “on”, select the programmed operation mode. At this stage, the STF terminal is the source of the start signal. When STF is “on”, the inverter begins to run in the programmed operation mode at the first section. When STF is “off”, the invert stops running, and STR becomes the pause signal source. When STR is “on”, the operation will be suspended. When STR is “off”, the operation will be continued (continues from the suspended section). For details, please refer to P.100~P.108, P.111~P.118, P.121~P.123, P.131~P.138.
- (6). In the external mode, the manual operation cycle mode is selected when MPO is “on”. For details on parameter and operation, please refer to P.100~P.108, P.111~P.118, P.121~P.123, P.131~P.138.

## 5.37 Slip Compensation Coefficient (P.89)

### P.89 “Slip compensation coefficient”

- Setting up this parameter appropriately enables the rotation speed of the motor under rated current to be closer to the set rotation speed.
- This function is only valid under the V/F mode; i.e., It is effective when P.300 = 0.

Parameter	Factory setting	Setting range	Remarks	
89	0	0~10	0	Slip compensation is forbidden.
			10	The compensation value is 3% of the target frequency when P.89 = 10.

## 5.38 Frequency Jump (P.91~P.96)

### P.91~P.96 “Frequency jump”

- To avoid system’s mechanical resonance frequency when running the motor, the inverter provides three sets of jump frequencies, namely, P.91 (the first set), P.92 (the second set), and P.95 and P.96 (the third set).

Parameter	Factory setting	Setting range	Remarks
91~96	99999	0~400Hz, 99999	99999: invalid

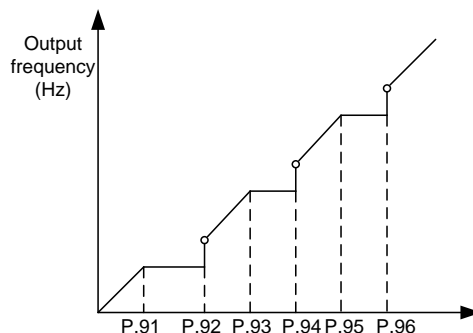

## <Setting>

- For example: assuming P.91=45 and P.92=50;  
 If the target frequency  $\leq 45\text{Hz}$ , then the steady output frequency=the target frequency.  
 If  $45\text{Hz} \leq \text{target frequency} < 50\text{Hz}$ , then the steady output frequency=45Hz.  
 If the target frequency  $\geq 50\text{Hz}$ , then the steady output frequency=the target frequency.

Note: 1. During the acceleration / deceleration period, the output frequency of the inverter will still pass through the jump frequency.  
 2. When P.91=99999 or P.92=99999, the first set of frequency jump is invalid.  
 When P.93=99999 or P.94=99999, the second set of frequency jump is invalid.  
 When P.95=99999 or P.96=99999, the third set of frequency jump is invalid.

## 5.39 Programmed Operation Mode (P.100~P.108, P.111~P.118,

### P.121~P.123, P131~P.138)

P.100 “Minute/second selection”

P.101~P.108 “Runtime of each section”

P.111~P.118

“Acceleration/deceleration time of each section”

P.121 “Run direction in each section”

P.122 “Cycle selection”

P.123 “Acceleration/deceleration time setting selection”

P.131~P.138 “Frequency of each section”

— Related parameters —

P.7 “Acceleration time”  
 P.8 “Deceleration time”  
 P.21 “Acceleration/deceleration time increments”  
 P.80~P.84, P.86,P.126~P.128  
 “Multi-function terminals selection”

Parameter	Factory setting	Setting range	Remarks	
100	1	0, 1	0	The minimum increment of run time is 1 minute.
			1	The minimum increment of run time is 1 second.
101~108	0s	0.1~3600s	---	
111~118	0s	0~600s	P.21=0	
		0~6000s	P.21=1	
121	0	0~225	---	
122	0	0~8	0: Cycle function invalid; 1~8: Run circularly	
123	0	0, 1	---	
131~138	0 Hz	1~400Hz	---	

## <Setting>

### 1. Programmed operation mode

- The calculation of runtime and acceleration/deceleration time in each section is presented in the figure below:

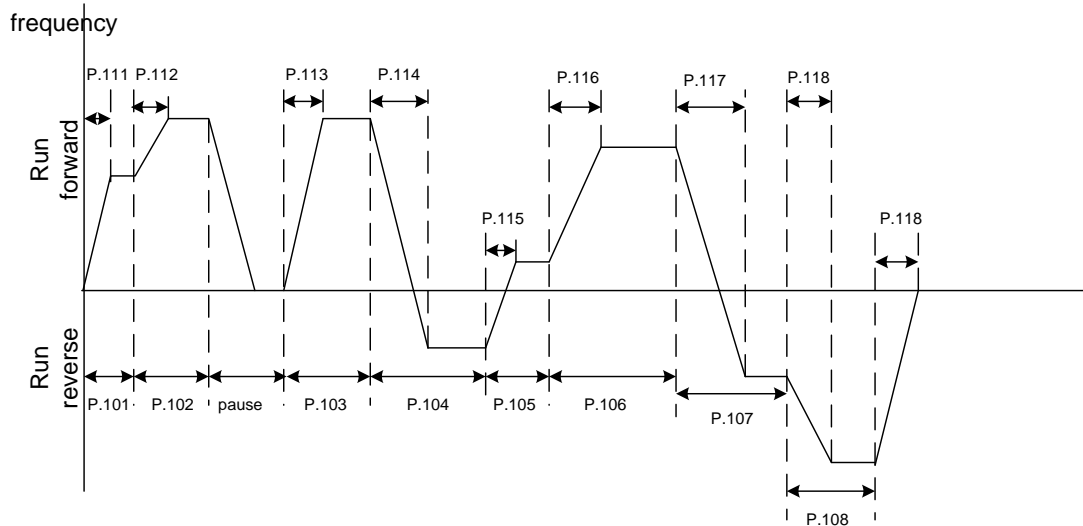

- The run direction is set in binary form (8-bit), and then translated to decimal form and stored in P.121. “1” means run forward, and “0” means run reversely. The highest bit is the run direction of section 8, while the lowest bit is the direction of the section 1.

For example: Suppose that section 1 is run forward, section 2 is run reverse, section 3 is run reverse, section 4 is run forward, section 5 is run reverse, section 6 is run forward, section 7 is run forward, section 8 is run reverse, then the value in binary form is 01101001.

$$P.121 = 0 \times 2^7 + 1 \times 2^6 + 1 \times 2^5 + 0 \times 2^4 + 1 \times 2^3 + 0 \times 2^2 + 0 \times 2^1 + 1 \times 2^0 = 105$$

- When P.122=0, it will not run in circular motion.
- When P.122 is 1~8, it is the initial sectional speed at the beginning of the cycle.  
For example: When P.122=3, the inverter will run circularly from the third section to the eighth section after it finishes its running from the first section to the eighth section.
- When P.123 = 0, the acceleration time is determined by P.7, and the deceleration time is determined by P.8.
- When P.123 = 1, the acceleration time and deceleration time are both determined by P.111~P.118.

### 2. Manual operation cycle mode

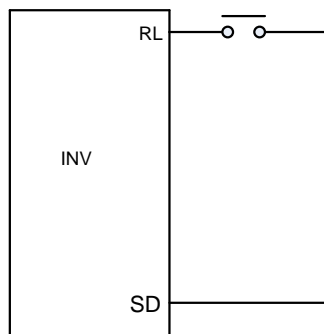

The wiring diagram for setting up the manual operation cycle

- Insert an impulse type switch between RL and SD.
- After turning on the power, set P.80=35 according to terminals wiring. Set corresponding parameter P.80 to 35. The inverter is on standby at this point.
- The mode of operation is shown in the figure below:

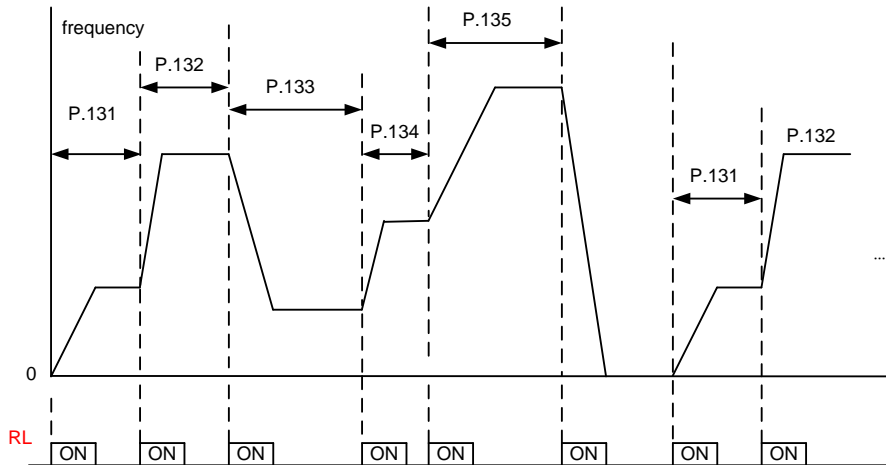

Note: 1. The inverter can run eight levels of speed in the procedure, and the frequency is determined by P.131~P.138.

2. If there is any section set to zero, the inverter will be on standby in this section. In other word, P.131 has to be nonzero when this mode is selected. Like the figure above, regardless of the value of P.137 and P.138, the inverter will stop when the switch is pressed for the sixth time.

3. The rotation of the manual operation cycle mode is unilateralism. It has nothing to do with P.121 or the signals of STF and STR.

## 5.40 Operation Panel Monitoring Selection (P.110)

### P.110 “Operation panel monitoring selection”

Parameter	Factory setting	Setting range	Remarks	
110	1	0, 1, 2	0	When the inverter starts, the operation panel enters the monitoring mode automatically, and the screen displays the output frequency.
			1	When the inverter starts, the screen of the operation panel displays the target frequency.
			2	When the inverter starts, the operation panel enters the monitoring mode automatically, and the screen displays the current pressure and feedback pressure of the constant pressure system (note).

Note: When P.110 = 2, the screen display shows two sections. A decimal point is used to separate the boundaries. What is on the left is the target pressure of the constant pressure system and what is on the right is the feedback pressure of the constant pressure system. As is shown in this figure,



, 20 denotes that the target pressure of the constant pressure system is 2.0kg/cm<sup>2</sup>; 30 denotes that the feedback pressure of the constant pressure system is 3.0kg/cm<sup>2</sup>.

## 5.41 Zero-Speed Function (P.151~P.152)

### P.151 “Zero-speed control function selection”

### P.152 “Voltage instruction at zero-speed control”

- Make sure that P.13 (Start frequency) is set to zero when using this function.

Parameter	Factory setting	Setting range	Remarks	
151	0	0, 1	0	There is no output at zero-speed.
			1	Control by DC (Note 1 and 3)
152	4% (7.5kW or below)	0~30%	(Note 2)	
	2% (11kW~55kW)			
	1% (75kW or above)			

Note: 1. The output mode is selected by the value of P.151. When P.151 is 0, then there is no output. When P.151 is 1, then the voltage of output DC voltage of P.152 is the keep torque.  
 2. Suppose that P.152 = 6%, then the output voltage of zero speed is 6% of **base frequency voltage** P.19.  
 3. This function is valid only at V/F, close-loop V/F control system, and close-loop vector control mode. For more details, please refer to the motor control mode parameter P.300 and the feedback control parameter P.350~P.354.

## 5.42 OverTorque Detection (P.155~P.156)

### P.155 “Over torque detection level”

### P.156 “Over torque detection time”

Related parameters

- P. 40 “Muti-function output terminal SU function selection”
- P. 85 “Function selection for multi-function relay”
- P. 129 “Muti-function terminal RUN function selection”
- P. 130 “Multi-function terminal FU/10X function selection”

- When the value of P.155 is nonzero, the function of over torque detection is selected.

# Parameter Description

- When the output current exceeds the detection level of over torque (P.155) and the detection time of over torque (P.156), then inverter alarm OL2 will go off and the inverter will stop the operation. If multi-function output terminal SU-SE(P.40), RUN-SE (P.129), FU/10X-SE(P.130), multi-function relay ABC(P.85) are set as over-load alarm (set the value to 3), then the inverter will send out signals. For details, please refer to P.40, P.85, P.129~P.130 in Chapter 5

Parameter	Factory setting	Setting range	Remarks	
155	0%	0~200%	0	No detection of over torque
			0.1~200%	During over torque detection, OL2 alarm is displayed and the motor stops.
156	2s	0.1~60s		

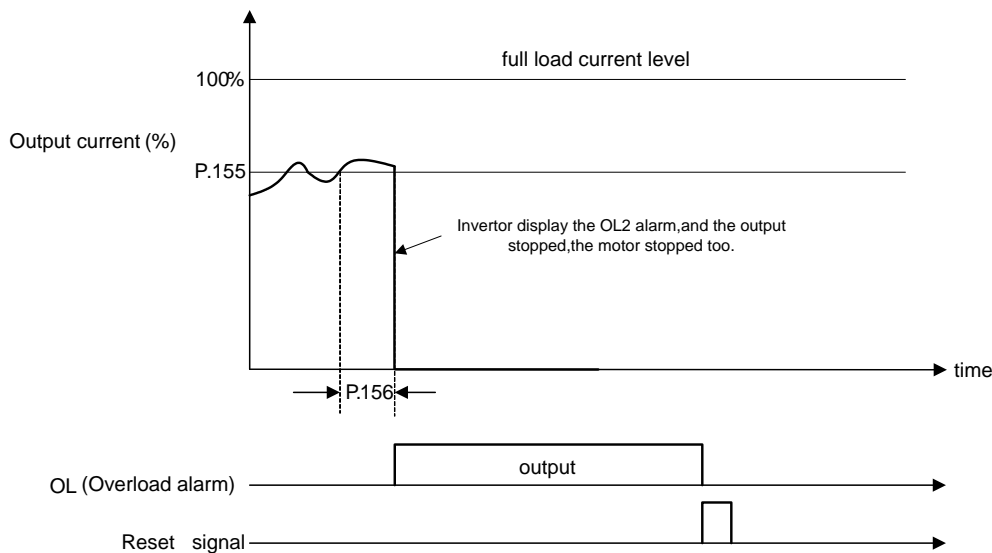

## 5.43 External Terminals Filter Adjusting Function (P.157)

### P.157 "External terminals filter adjusting function"

Parameter	Factory default value	Setting range
157	4 ms	0~200ms

- P.157 is used to select response time to the signal of external terminals.

## 5.44 External Terminal Power Enable Function(P.158)

### P.158 “External terminal power enable”

Parameter	Factory default value	Setting range
158	0	0~1

- If P.158=1, select power enables on the external terminals. In this situation, if the functions of the multi-function control terminals before turning on the power are STF, STR, RUN and MPO, and the corresponded external terminals are short circuit, and then the inverter will not run immediately after turning on the power. The inverter will run only after short circuit these terminals again. When P.158=0, make these terminal short circuit before turning on the power, and the inverter will run immediately after the power is turned on.

## 5.45 Energy-Saving Control Function (P.159)

### P.159 “Energy-saving control function”

Parameter	Factory setting	Setting range	Remarks
159	0	0	Normal running mode
		1	Energy-saving running mode

- Under the energy-saving running mode, the inverter will control the output voltage automatically in order to reduce the output power losses to the minimum when the inverter is run at a constant speed.

Note: 1. After selecting the energy-saving running mode, the deceleration time may be longer than the setting value. In addition, the properties of the regular torque load will produce abnormal voltage more easily. Please slightly prolong the deceleration time.

2. In the energy-saving running mode, only the V/F control mode is available. That is, only P.300=0 is valid.

3. For big load purposes or machines with frequent acceleration/deceleration, the energy-saving effect may be poor.

## 5.46 Multi-Function Display (P.161)

### P.161 “Multi-function display selection”

Parameter	Factory setting	Setting range	Remarks	
161	0	0~11	0	The monitoring voltage file displays the current voltage.
			1	The monitoring voltage file displays the current voltage between P and N terminals.
			2	The monitoring voltage file displays the accumulation rate of temperature increase of the inverter.
			3	The monitoring voltage file displays the current target pressure of the constant pressure system.
			4	The monitoring voltage file displays the current feedback pressure of the constant pressure system.
			5	The monitoring voltage file displays the current operation frequency.
			6	The monitoring voltage file displays the current electronic thermal accumulation rate.
			7	The monitoring voltage file displays the signal value (V) of 2-5 simulating input terminals.
			8	The monitoring voltage file displays the signal value (mA) of 4-5 simulating input terminals.
			9	The monitoring voltage file displays the output power (kW).
			10	The monitoring voltage file displays PG card's feedback rotation speed.
			11	The output power

## 5.47 PID Control (P.170~P.183)

P.170 “PID function selection”

P.171 “PID feedback control method selection”

P.172 “PID proportion Gain”

P.178 “Sleep detects deviation”

P.173 “PID Integration Gain”

P.179 “Sleep detects duration time”

P.174 “PID Differential Gain”

P.180 “Revival level”

P.175 “Abnormal deviation level”

P.181 “Outage level”

P.176 “Exception duration time”

P.182 “Integral upper limit frequency”

P.177 “Exception handling mode ”

P.183 “Deceleration step length with stable pressure”

- During the operation of PID control, the frequency displayed on the screen is the output frequency of the inverter.
- The output frequency during the operation is similar to output frequency during the normal operation. They are both limited within the upper limit P.182 and the lower limit P.2.
- For input signal filtering of terminal 2-5 and terminal 4-5, please refer to the instructions for P.60.
- The sketch map of PID function is shown as follows:

Parameter	Factory setting	Setting range	Remarks	
170	0	0, 1, 2	0	PID function non-selected
			1	The target value is determined by <u>P.225</u> . The feedback value is determined by the voltage of terminal 2-5.
			2	The target value is determined by P.225. The feedback value is determined by the voltage of terminal 4-5.
171	0	0, 1	0	Negative feedback control The calculation for the deviation is target value minors the feedback value. When an increase in the output frequency will increase the feedback value, select this setup.
			1	Positive and feedback control The calculation for the deviation is feedback value minors the target value. When an increase in the output frequency will decrease the feedback value, select this setup.
172	20	1~100	This gain determines the proportion controller’s impact on feedback deviation. The greater the gain, the faster the impact. Yet a gain that is too big will cause vibration.	

# Parameter Description

Parameter	Factory setting	Setting range	Remarks
173	1s	0~100s	This parameter is use to set integral controller's integral time. When the integral gain is too big, the integral effect will be too weak to eliminate steady deviation. When the integral gain is too small, the system vibration frequency will increase, and therefore the system may be unstable.
174	0 ms	0~1000ms	This gain determines deviation controller's impact on the amount of change of the deviation. Appropriate deviation time can reduce the overshooting between the proportion controller and the integral controller. Yet when the deviation time is too large, system vibration may be induced.
175	0	0~100%	---
176	30s	0~600s	---
177	0	0, 1, 2	0   Free stop
			1   Decelerate and stop
			2   Continue to run when the alarm goes off
178	0	0~100%	---
179	1s	0~255s	---
180	90%	0~100%	---
181	40Hz	0~120Hz	---
182	50Hz	0~120Hz	P.189=1   When the deviation value accumulated with the integral time, an upper limit for deviation accumulation should be set.
	60Hz		P.189=0
183	0.5Hz	0~10Hz	When the feedback pressure satisfies the deviation value for stopping the machine and the set time (in seconds) for stopping the machine for detection is reached, the inverter will take the P.183 step to reduce the frequency.

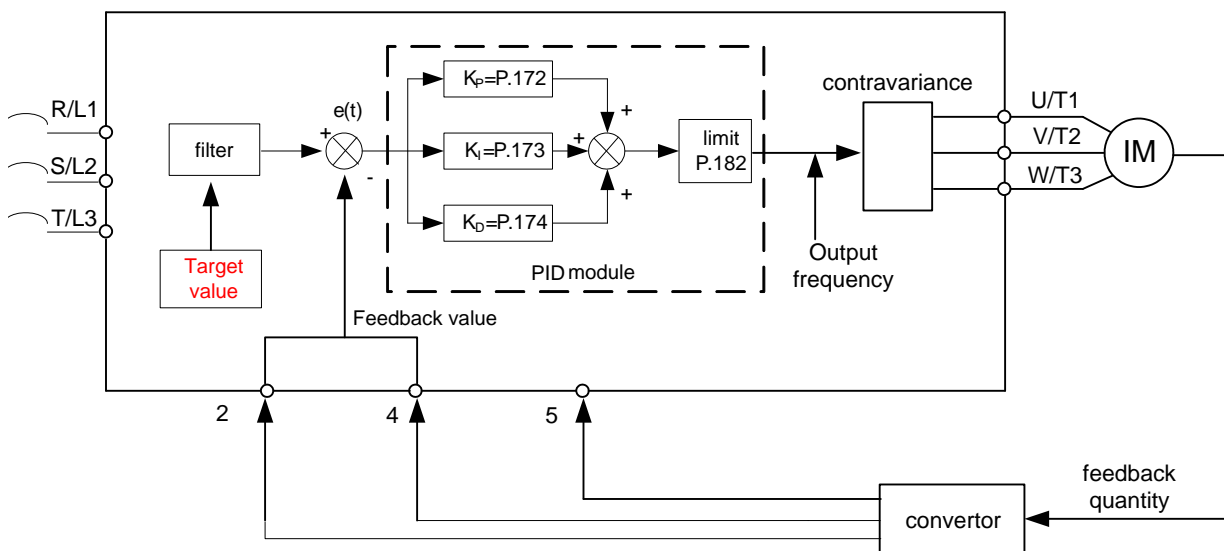

- When the output frequency reaches the set value of P.182, the feedback value will be less than the product of the target value and P.172. In addition, when the duration lasts more than the set value of P.176, PID will be considered as abnormal and handled according to the set value of P.177.

For example, when P.175=60%, P.176=30s, P.177=0 and P.182=50Hz, the output frequency reaches 50Hz, and the feedback value is lower than 60% of the target feedback value for 30 seconds continuously, *Pid* alarm will be display and the inverter will be stopped freely.

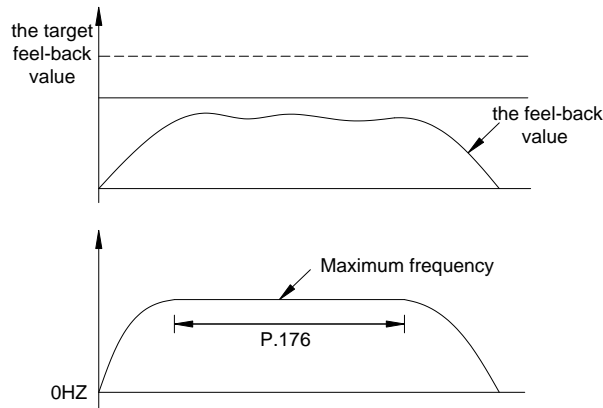

- If P.176 is set to 0, then the set values of P.179, P.180, P.181 and P.183 are invalid. If the set value of P.178 is nonzero, than PID's sleep function will be activated. When the absolute value of the deviation between the feedback value and the target feedback value is less than the sleep detected deviation value for the duration of P.179's sleep detection time, the inverter will steadily reduce the output frequency. Once the output frequency of the inverter is less than the machine stop level of P.181, the inverter will decelerate and stop. When the feedback value is lower than the wake-up level, the output frequency of the inverter will again be controlled by PID.

For example, if P.178=5%, P.179=1.0s, P.180=90%, P.181=40Hz, and P.183=0.5Hz, and when the feedback value is at a stable zone, i.e., larger than 95% of the target feedback value but less than 105% of the target feedback value, the inverter at the stable zone will reduce the output frequency by 0.5Hz/second. When the output frequency of the inverter is less than 40Hz, the inverter will directly decelerate and stop. When the feedback value lower than 90% of the target feedback value, the inverter will wake up and the output frequency will again be controlled by PID.

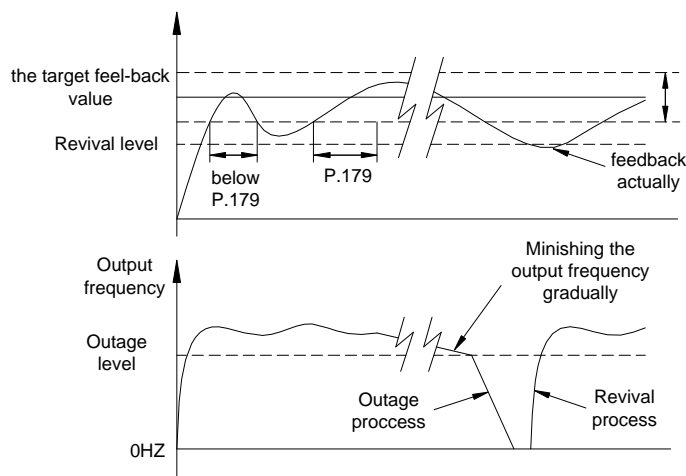

## <Setting>

- PID gain simple set up:
  - (1). Use proportion control to gradually increase the proportion gain so the system is close to the borderline vibration.
  - (2). Set the proportion gain to 80% of the set value in (1). Gradually increase the integral gain until a satisfying dynamic performance is achieved.
  - (3). Keep the integral gain the same while changing the proportion gain. Observe whether the control procedure is improved. If yes, keep adjusting until the situation is acceptable. If not, slightly increase the original proportion gain before adjusting the integral gain to improve the control process. Try it repetitively until the proportion gain and the integral gain are acceptable.
  - (4). Usually, deviation gain is not used under normal control. When introducing the deviation gain, the proportion gain and the integral gain can be adequately adjusted. Same as the procedure mentioned above, the adjustment on the deviation time has to be performed repetitively until the user is satisfied with the control process.

Note: When P.177=2, the panel has no alarm display but the multi-function output terminal has alarm detection. To turn off the alarm, reset P.997 or turn down the power.

## **5.48 4-5 Terminal Disconnection Handling Function (P.184)**

### P.184 “4-5 terminal disconnection handling”

Parameter	Factory setting	Setting range	Remarks
184	0	0~3	---

## <Setting>

- When P.184=0, the inverter will decelerate to 0Hz when disconnected. After reconnecting the inverter, the inverter will accelerate to the corresponding frequency.
- When P.184=1, the inverter will decelerate to 0Hz when disconnected. After reconnecting the inverter, the inverter will accelerate to the corresponding frequency. Meanwhile, the multi-function output terminal will set off the alarm. Reconnection will clear the alarm.
- When P.184=2, the panel will display the “AEr” alarm when disconnected. The inverter will stop immediately. Reset to clear the alarm.
- When P.184=3, the inverter will run continuously according to the frequency command before the disconnection. The multi-function output terminal will set off the alarm. Reconnect to clear the alarm.

Note: Please refer to P.40. For wiring, please refer to Section 3.5.

## 5.49 SF-G Model Selection Function (P.186)

### P.186 “SF-G model selection function”

Parameter	Factory setting	Setting range	Remarks
186	0	0~1	---

#### <Setting>

- When P.186=0, execute P.998 to return to the default value. Next execute the reset function of P.997. Select the SF (the fans and water pump type) model.
- When P.186=1, execute P.998 to return to the default value. Next execute the reset function of P.997. Select the SF-G (constant torque type) model.

## 5.50 Firmware version (P.188)

### P.188 “Firmware version”

- It is used to display that the current Firmware version of the inverter is readable only.

## 5.51 Factory Setting Function (P.189)

### P.189 “Factory setting function”

Parameter	Factory setting	Setting range	Remarks	
189	1	0, 1	0	The default value of frequency-related parameter belongs to the 60Hz system.
			1	The default value of frequency-related parameter belongs to the 50Hz system.

- According to different power frequency and the default motor frequency, the user can select frequency related parameters. The default value is either 50Hz or 60Hz. Description on relevant parameters are presented in the table below:

Parameter	Name	Setting range	Minimum value
<u>P.3</u>	Base frequency	0~400Hz	0.01Hz
<u>P.20</u>	Acceleration / deceleration reference frequency	1~400Hz	0.01Hz
<u>P.38</u>	The maximum operation frequency (the target frequency is set by the input signal of terminal 2-5)	1~400Hz	0.01Hz
<u>P.39</u>	The maximum operation frequency (the target frequency is set by the input signal of terminal 4-5)	1~400Hz	0.01Hz

# Parameter Description

Parameter	Name	Setting range	Minimum value
P.55	Frequency display reference	0~400Hz	0.01Hz
P.66	Stall prevention operation reduction starting frequency	0~400Hz	0.01Hz
P.182	Integral upper limit frequency	0~120Hz	0.01Hz
P.195	Frequency corresponds to the maximum input voltage of terminal 2-5	0~400Hz	0.01Hz
P.197	4-5 terminal's maximum input current corresponded frequency	0~400Hz	0.01Hz
P.305	Motor rated frequency	0~400Hz	0.01Hz

Note: 1. Adjusting the default values from the table above would affect the acceleration/deceleration time, the output voltage, the voltage signal rated frequency, etc., and bring problems to the customers. In this case, the customers have to adjust the corresponding parameters, such as P.7, P.8, to more reasonable values.

2. If the customer would like to adjust the factory setting to 60Hz, please follow the following steps:  
 (1). Set P.189=0.  
 (2). Set P.998 to the factory default value (at this point, frequency-related parameters of the inverter will be reset to 60Hz. The factory default value of P.189 is 0). For details on P.998 procedures, please refer to P.998 in Chapter 5.

3. To resume the 50Hz system, the customer should set P.189 to 1 and then follow Step 2 in Note 2 (at this time, the factory setting of P.189 is 1).

## 5.52 2-5 Terminal Input Signal (P.192~P.195)

P.192 “2-5 terminal minimum input voltage”      maximum input voltage of terminal 2-5”

P.193 “2-5 terminal maximum input voltage”

P.194 “Frequency corresponds to the minimum input voltage of terminal 2-5”

P.195 “Frequency corresponds to the

— Related parameters —

P. 73 “Voltage signal selection”  
 P.80~P.84, P.86  
 “Multi-function terminals selection”  
 P. 189 “Factory setting function”

Parameter	Factory setting	Setting range	Remarks
192	0	0~10	---
193	0	0~10	---
194	0 Hz	0~60Hz(Note 3)	---
195	50Hz	0~400Hz(Note 3)	P.189=1

## Parameter Description

Parameters

### <Setting>

- Calibration procedures

1. Make sure that the voltage signal has been correctly connected to the inverter.
2. Assume that the preset criterion is that “when the voltage signal is A, the expected operation frequency will be 20Hz”.Then, adjust the voltage signal to A, and set P.194 to 20. At this point, the value of A will be written into P.192 automatically.
3. Assume that the preset criterion is that “when the voltage signal is B, the expected operation frequency will be 60Hz”.Then, adjust the voltage signal to B, and set P.195 to 60. At this point, the value of B will be written into P.193 automatically.

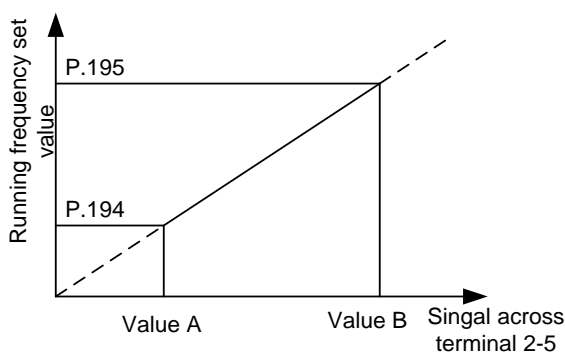

Note: 1. The equation of the curve above is:

$$\frac{\text{Running frequency}-\text{P.194}}{\text{Voltage value}-\text{Value A}} = \frac{\text{P.195}-\text{P.194}}{\text{Value B}-\text{Value A}}$$

2. If an actually stable signal input cannot be provided, the user can manually set the value of P.192 and P.193. The value of P.192 corresponds to the set frequency of P.194, while the value of P.193 corresponds to the set frequency of P.195. When manually setting up the values, first confirm the range of frequency parameters, P.194 and P.195. Then adjust the value of voltage parameters P.192 and P.193.
3. Rest any of the parameter from P.192 to P.195; the curve of P.38 will be invalid.

### 5.53 4-5 Terminal Input Signal (P.196~P.199)

P.196 “4-5 terminal minimum input current corresponded frequency”

P.197 “4-5 terminal maximum input current corresponded frequency”

P.198 “4-5 terminal minimum input current”

P.199 “4-5 terminal maximum input current”

—Related parameters—

P.80~P.84, P.86, P.126~P.128

“Multi-function terminals selection”

P.189 “Factory setting function”

# Parameter Description

Parameter	Factory setting	Setting range	Remarks
196	0 Hz	0~60Hz(Note 3)	---
197	50Hz	0~400Hz(Note 3)	P.189=1
	60Hz		P.189=0
198	0	0~20	---
199	0	0~20	---

## <Setting>

### • Calibration procedures

1. Make sure that the current signal has been correctly connected to the inverter.
2. Assume that the preset criterion is that “when the current signal is A, the expected operation frequency will be 20Hz”.Then, adjust the current signal to A, and set P.196 to 20. At this point, the value of A will be written into P.198 automatically.
3. Assume that the preset criterion is that “when the current signal is B, the expected operation frequency will be 60Hz”.Then, adjust the current signal to B, and set P.197 to 60. At this point, the value of B will be written into P.199 automatically.

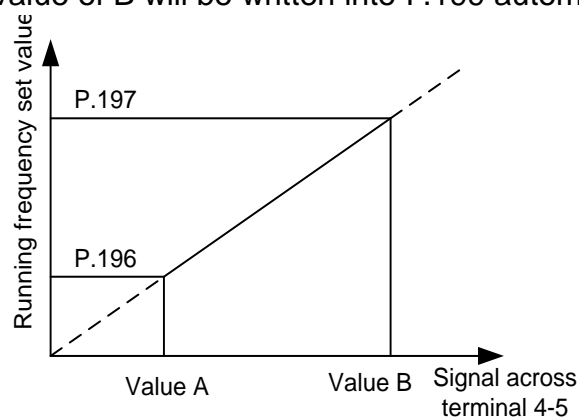

Note: 1. The equation of the curve above is:

$$\frac{\text{Running frequency}-\text{P.196}}{\text{Current value}-\text{Value A}} = \frac{\text{P.197}-\text{P.196}}{\text{Value B}-\text{Value A}}$$

2. If an actually stable signal input cannot be provided, the user can manually set the value of P.198 and P.199. The value of P.198 corresponds to the set frequency of P.196, while the value of P.199 corresponds to the set frequency of P.197. When manually setting up the values, first confirm the range of frequency parameters, P.196 and P.197. Then adjust the value of current parameters P.198, P.199.
3. Rest any of the parameter from P.196 to P.199; the curve of P.39 will be invalid.

## Parameter Description

### 5.54 Multi-machine Constant Pressure System Function (P.200, P.209,

### P.210, P.213~P.217, P.223~P.225)

P.200 “Constant pressure system function selection”

P.209 “Maximum frequency duration”

P.210 “Minimum frequency duration”

P.213 “Acceleration time for starting the commercial power supply frequency”

P.214 “Deceleration time for starting the commercial power supply frequency”

P.215 “Maximum frequency”

P.216 “Minimum frequency”

P.217 “Motor switchover permitted deviation”

P.223 “Analog feedback [bias pressure](#)”

P.224 “Analog feedback [gain pressure](#)”

P.225 “Panel command”

Parameter	Factory setting	Setting range	Remarks
200	0	0~14	P.200 is the function parameter of the multi-machine constant pressure system (the multi-channel card has to be purchased for using this function. Please refer to the manual for the multi-channel card for more details).
209	5min	0.1~10min	It is for setting up the time for the output frequency of the inverter to increase the servo motor (pump) after reaching the maximum frequency,
210	5min	0.1~10min	Set the determining time as between the output frequency of the inverter reaching the minimum frequency and the decreasing of the servo motor (pump).
213	5s	0.01~20s/0.1~200s	When <u>P.21</u> =0, the unit of P.213 and P.214 is 0.01s.
214	5s	0.01~20s/0.1~200s	When P.21=1, the unit of P.213 and P.214 is 0.1s.
215	50Hz	20~60Hz	When the inverter pump operation frequency reaches P.215, the register controlled by the increasing pump will start counting. When the output frequency is less than P.215, the register controlled by the increasing pump will be reset to zero.

## Parameter Description

Parameter	Factory setting	Setting range	Remarks
216	20Hz	0~20Hz	When the inverter pump operation frequency is less than P.216, the register controlled by the decreasing pump will start counting. When the output frequency is greater than P.216, the register controlled by the decreasing pump will be reset to zero.
217	0	0%~20%	The bias between the command value and the feedback value is used as a reference for determining whether the output frequency of the inverter is close to the maximum or the minimum frequency and whether the code of the number of motors should be increased or decreased. When the bias is greater than the set value, the number of the motor (pump) has to be increased / decreased.
223	0%	0~100%	When <u>P.170</u> =1, 2, set 2-5 terminal to 0V or the corresponded value when 4-5 terminal is 4mA.
224	100%	0~100%	When P.170=1, 2, set 2-5 terminal to 5V or the corresponded value when 4-5 terminal is 20mA.
225	20%	0~100%	When using the multi-machine constant pressure system, the pressure command is not entered by an analog input but by the code used for setting up the operation panel.
		99999	

### <Setting>

- When P.200=1 and P.85=11, integrating PID function parameters can realize multimachine constant pressure system and the AC control frequency motor contactor. When sending the stop command to the inverter, all the motors (pumps) will be stopped.
- P. 213 is the time when decreasing the pump, the setup reference for accelerating the output frequency of the inverter from the minimum frequency to the maximum frequency, and the time for the corresponding acceleration/deceleration base frequency.
- P. 214 is the time when increasing the pump, the setup reference for decelerating the output frequency of the inverter from the maximum frequency to the minimum frequency, and the time for the corresponding acceleration/deceleration base frequency.
- When P.225=99999 and P.170=1, 4-5 current sets the target frequency and 2-5 voltage for feedback pressure. When P.225=99999 and P.170=2, 2-5 voltage sets the target voltage, and 4-5 current for the feedback pressure.

**Note:** When external 4-5 analog signal is given as pressure, please refer to the parameter P.17; Setting

## Parameter Description

- Fixed mode increasing pump control operation is shown in the figure below:

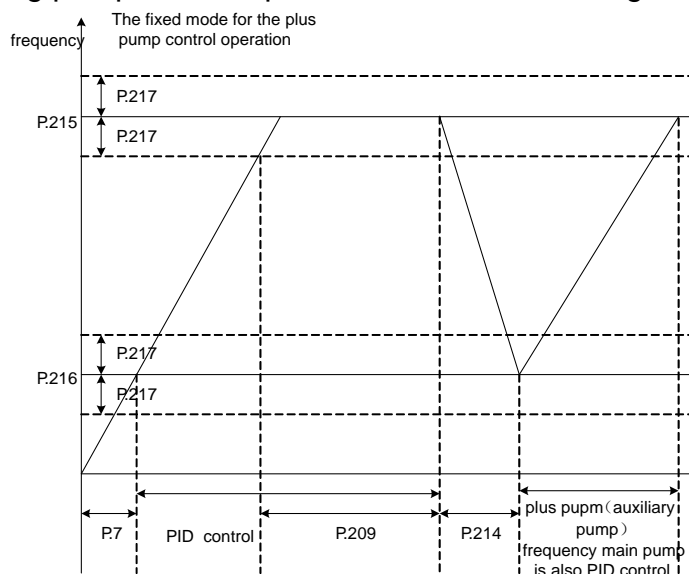

When the inverter is running, if the pressures command (or the frequency command) is larger than the feedback value continuously, PID output (equals to the output frequency) will increase until reaching the maximum frequency (P.215). This state will continue until the time assigned by P.209. If the bias between the command value and the feedback value is larger than the set value of P.217, increasing pump control will be performed.

- Decreasing pump control operation is shown in the figure below:

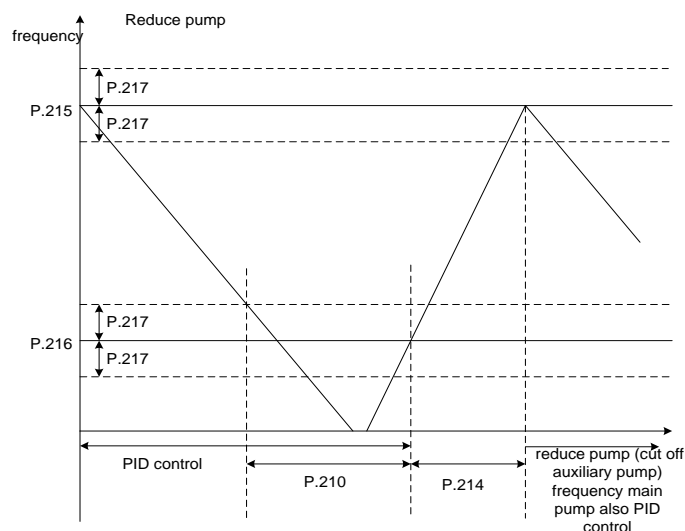

When the inverter is running, if the pressure command (or the frequency command) is smaller than the feedback value continuously, PID output will decrease until reaching the minimum frequency (P.216). This state will continue until the time assigned by P.210. If the bias between the command value and the feedback value is larger than the set value of P.217, decreasing pump control will be performed.

Note: 1. For P.217, the amount of bias of the command value, enters this value in the form of percentage. The set unit is 0.1%. If it is set as 0%, then once the maximum or the minimum value is reached, the motor (pump) will be increased / decreased regardless of the bias value.

2. Adjust the setup of P.213 and P.214 to stabilize the voltage change. But is the setup is too short, over-current may happen. Please be cautious.

## Parameter Description

Parameters

### 5.55 Backlash Compensation Function (P.229~P.233)

P.229 “Backlash compensation function selection”

P.230 “The backlash compensation acceleration interrupt frequency”

P.231 “The backlash compensation acceleration interrupt time”

P.232 “The backlash compensation deceleration interrupt frequency”

P.233 “The backlash compensation deceleration interrupt time”

Parameter	Factory setting	Setting range	Remarks
229	0	0~1	---
230	1Hz	1~400Hz	---
231	0.5s	0~360s	---
232	1Hz	1~400Hz	---
233	0.5s	0~360s	---

- Backlash countermeasures:

What is backlash compensation?

Reduction gears have an engagement gap and a dead zone between forward and reverse rotation. This dead zone is called backlash, and the gap disables a mechanical system from following motor rotation.

More specifically, a motor shaft develops excessive torque when the direction of rotation changes or when constant-speed operation shifts to deceleration, resulting in a sudden motor current increase or regenerative status.

To avoid backlash, acceleration/deceleration is temporarily stopped. Set the acceleration/deceleration stopping frequency and time in P.229 and P.233.

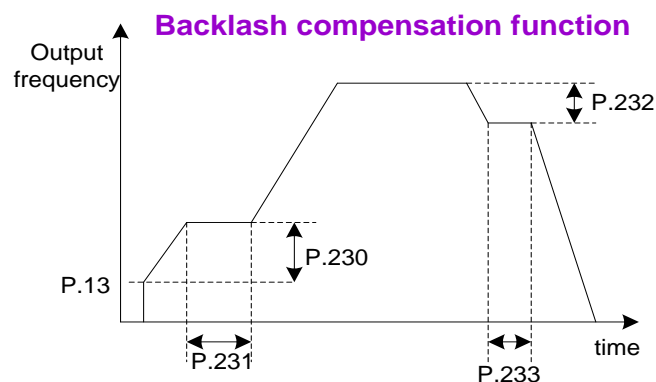

Note: 1. The setting of the backlash compensation will only prolong the acceleration/deceleration time during the period of interruption.

2. This function is only valid under the V/F mode; i.e., it is effective when P.300 = 0.

## 5.56 Triangular Wave Function (P.234~P.239)

P.234 “Triangular wave function selection”

P.235 “Maximum amplitude”

P.236 “Amplitude compensation for deceleration”

P.237 “Amplitude compensation for acceleration”

P.238 “Amplitude acceleration time”

P.239 “Amplitude deceleration time”

Parameter	Factory setting	Setting range	Remarks
234	0	0~2	---
235	10%	0~25%	---
236	10%	0~50%	---
237	10%	0~50%	---
238	10s	0~360s/0~3600 s	When <u>P.21</u> =0, the unit of P.238 and P.239 is 0.01s. When P.21=1, the unit of P.238 and P.239 is 0.1s.
239	10s	0~360s/0~3600 s	

### <Setting>

- If P.234 “Triangular wave function selection” is “1” and triangular wave operation signal (TRI) is turned on, triangular wave function will be valid. Set any parameter in P.80~P.84, P.86, P.126~P.128 “Input terminal selection function” to “36” and then assign the TRI signal for the external terminal.
- If P.234 “triangular wave function selection” is equal to “2,” the triangular wave function is effective at any given time.

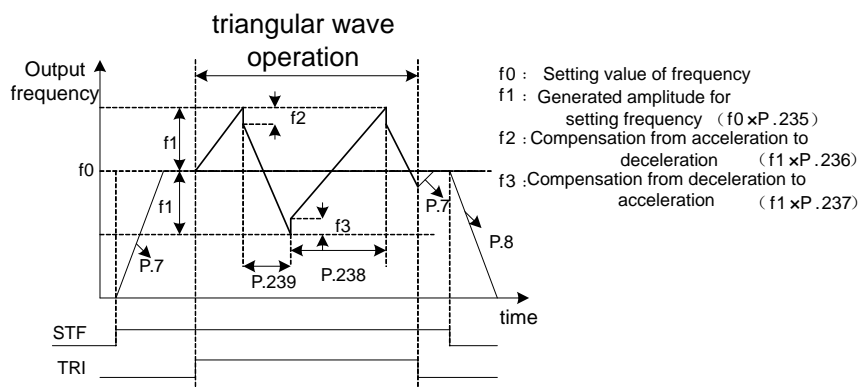

Note: 1. During the movement of the triangular wave, the output frequency is limited by the maximum and the minimum frequency.  
 2. If the amplitude compensation, i.e., P.236 and P.237, is too big, over-voltage will be tripped off and the stall prevention action will be executed automatically. Consequently, the set method will not

be carried out.

3. This function is only valid under the V/F mode; i.e., it is effective when  $P.300=0$ .

## Parameter Description

Parameters

### 5.57 Auxiliary Frequency Function (P.240)

#### P.240 “Auxiliary frequency function selection”

Parameter	Factory setting	Setting range	Remarks
240	0	0~4	---

#### <Setting>

- When P.240 is 0, no auxiliary frequency function is available.
- When P.240 is 1, operation frequency = basic frequency + auxiliary frequency (given by the 2-5 terminal).
- When P.240 is 2, operation frequency = basic frequency + auxiliary frequency (given by the 4-5 terminal).
- When P.240 is 3, operation frequency = basic frequency - auxiliary frequency (given by the 2-5 terminal).
- When P.240 is 4, operation frequency = basic frequency - auxiliary frequency (given by the 4-5 terminal).
- When the operation frequency is smaller than  $P.2$ , the operation frequency will be equal to the minimum limited frequency  $P.2$ . When the operation frequency is larger than  $P.1$ , the operation frequency will be equal to the maximum limited frequency  $P.1$ .

Note: The main frequency is set by the combination of the target frequency reference source DU01, communication and the multi-speed gear, or by 2-5、4-5 terminal.

### 5.58 DC Brake Function before Starting (P.242~P.244)

#### P.242 “DC injection brake function before starting selection”

#### P.243 “DC injection brake time before starting”

#### P.244 “DC injection brake voltage before starting”

Related parameters

P.13 “Starting frequency”

Parameter	Factory setting	Setting range	Remarks
242	0	0~1	---
243	0.5s	0~60s	---
244	4% (7.5kW or below)	0~30%	---
	2% (11kW~55kW)		

## Parameter Description

### <Setting>

- If P.242=0, DC injection brake function is not available before starting. If P.242=1, DC brake injection function is selected before starting. When the output frequency reaches the starting frequency P.13, a DC voltage (the set value of P.244) will be injected into the motor windings by the inverter, which is used to lock the motor rotor. The DC brake operation will last a period (the set value of P.243) before the motor starts.

See the figure below:

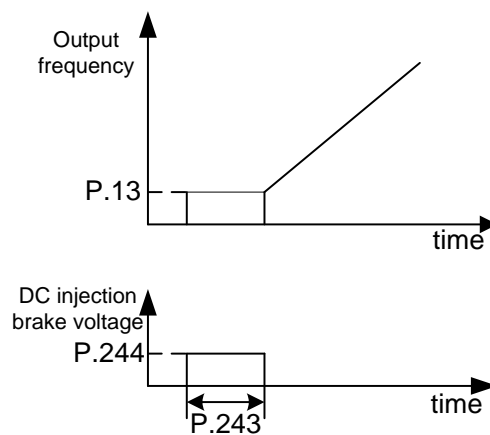

Note: This function is only valid under the V/F mode; i.e., it is effective when P.300=0.

## 5.59 Options for Stopping the Cooling Fan (P.245)

### P.245 “Cooling fan operation selection”

Parameter	Factory setting	Setting range	Remarks
245	0	0~3	---

### <Setting>

- When P.245=0, the fan will be turned on by the RUN signal. The fan will be turned off 30 seconds after the inverter stops.
- When P.245=1, turning on the power will turn on the fan. When the power is turned off, the fan will be off, too.
- When P.245=2, the fan will be turned on if the temperature of the heat sink is higher than 40°C. When the fan is turned off, the fan will be turned off, too.
- When P.245=3, the fan will be turned on when the temperature of the heat sink is higher than 40°C. When the temperature of the heat sink is lower than 40°C, the fan will be turned off.

## Parameter Description

### 5.60 Modulation Coefficient (P.246)

#### P.246 "Modulation coefficient"

Parameter	Factory setting	Setting range	Remarks
246	1	0.90~1.20	---

- P.246 is used to determine the ratio between the maximum output voltage and the input voltage. The users can use this parameter to obtain an output voltage that is higher than the input voltage. But the output voltage waveform at this point will generate distortion and contain assorted harmonics. It may also increase the motor torque harmonics and noises.

### 5.61 Commercial Power Supply Frequency Operation Function (P.247~P.250)

#### P.247 "MC switchover interlock time"

#### P.248 "Start waiting time"

#### P.249 "Automatic switchover frequency from inverter to commercial power supply frequency"

#### P.250 "Automatic switchover frequency range from commercial power supply to inverter"

Parameter	Factory setting	Setting range	Remarks
247	1s	0.1~100s	---
248	0.5 s	0.1~100 s	---
249	99999	0~60Hz, 99999	---
250	99999	0~10Hz, 99999	---

#### <Setting>

- P.249 is used to switch the frequency from inverter operation to commercial power supply operation. Between starting and P.249 inverter operation, an output frequency greater than P.249 will automatically change the inverter operation to commercial power supply operation. When P.249 is set to 99999, there is no automatic switchover.
- When P.250≠99999, automatic switchover is valid during the operation (P.249≠99999). After the inverter operation is switched bypass operation, if the frequency command is lower than (P.249–P.250), the operation will be switched to inverter operation and run by the

frequency of the frequency command. Inverter activation when the inverter start command (STF/STR) is turned off, the operation is also switched to the inverter operation.

## Parameter Description

- When P.250=99999, it is valid during automatic switchover operation (P.249≠99999). When the inverter start command (STF/STR) is turned off after the operation is changed from inverter operation to commercial power supply operation, the operation will be changed to the inverter operation and the motor will decelerate until it stops.

Examples for the commercial power supply frequency switchover function:

Assume that P.80=37, P.81=38, P.40=10 and P.130=9. The wiring diagram is presented below:

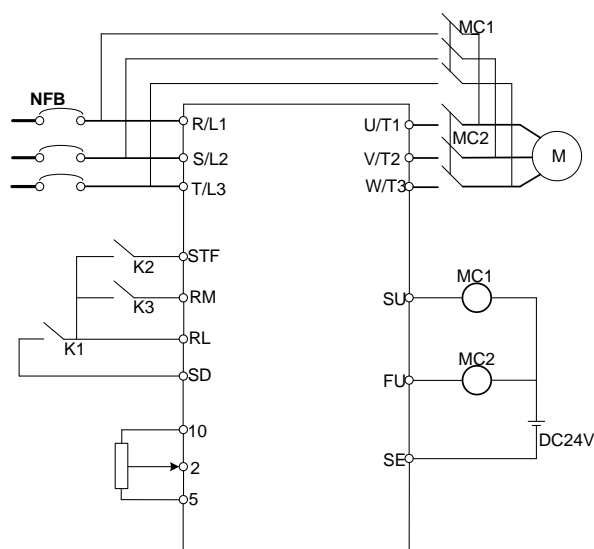

Please be cautious of the capacity of the output terminals. The used terminals vary according to the setup of P.40, P.85, P.129 and P.130 (output terminal function selection). When 10 is selected for the output terminal function, connect the relay that drives the commercial power supply frequency operation. When 9 is selected for the output terminal function, connect the relay that drives the inverter operation. When 37 is selected for the input terminal function, commercial power-supply operation switchover function is selected. When 38 is selected for the input terminal function, commercial power supply frequency operation switchover signal CS is selected.

### Warning:

1. MC1 and MC2 must be mechanically interlocked; the running direction of the inverter operation and the commercial power supply operation should be consistent.
2. Use the commercial power operation switchover function under the external operation mode.
3. STF/STR is effective when the CS signal is ON.

# Parameter Description

Here are some typical sequence diagrams for the switchover of the commercial power supply frequency:

1. No action sequence for the automatic switchover sequence (P.249=99999).

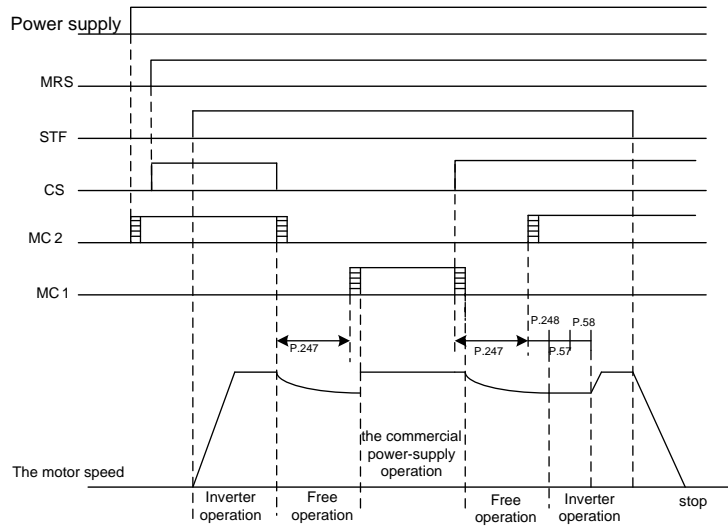

2. With action sequence for the automatic switchover sequence (P.249≠99999, P.250=99999).

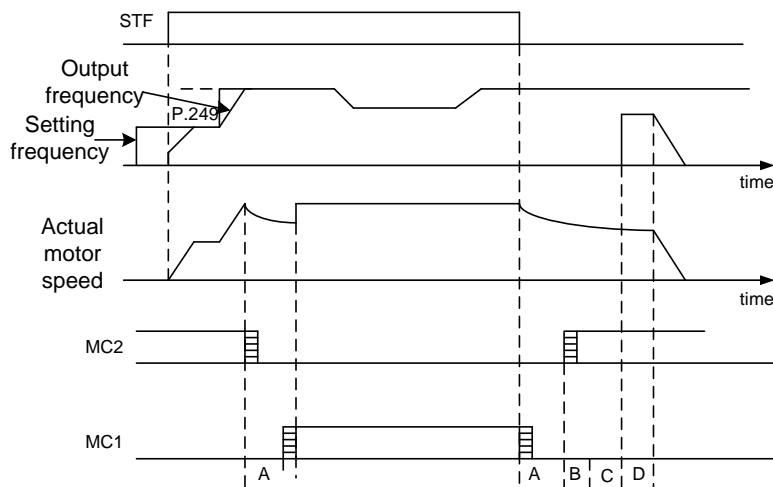

3. With action sequence for the automatic switchover sequence series (P.249≠99999, P.250 ≠ 99999).

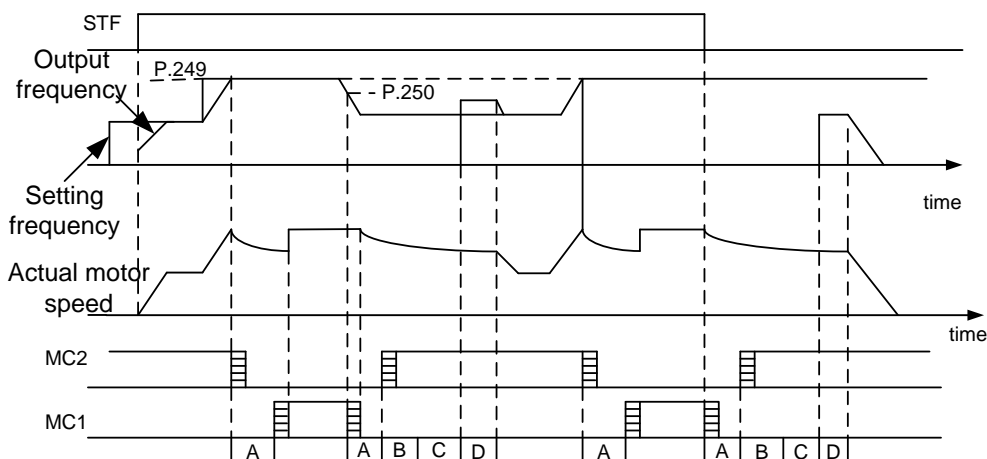

## Parameter Description

### Parameters

During the automatic switchover, A: P.247 MC switchover interlocking time; B: P.248 starting waiting time; C: P.57 restarting free operation time; D: P.58 restarting elevating time.

Note: 1. When the motor runs at 50Hz (or 60Hz), the commercial power supply will offer a more efficient operation than the inverter will. Moreover, during the inverter maintenance/inspection period, the commercial power supply circuit should be installed to prevent the motor from being stopped for too long.

2. To prevent the inverter from setting off the over-current alarm when changing between the inverter operation and the commercial power supply operation, the interlock measure has to be taken. Once the motor stops, it will be activated via the inverter. Switchover and interlock can be carried out through the inverter and a complicated commercial power supply if commercial power supply switchover sequence function that can send out the signal for electromagnetic contactor actions is used.

3. This function is only valid under the V/F mode; i.e., it is effective when P.300=0.

## 5.62 Injection Molding Machine Specific Functions (P.251~P.254)

P.251 "Injection molding machine mode selection"

P.252 "Flow channel weighted coefficient"

P.253 "Pressure channel weighted coefficient"

P.254 "Corner frequency"

Parameter	Factory setting	Setting range	Remarks
P.251	0	0~4	---
P.252	100%	0~100%	---
P.253	100%	0~100%	---
P.254	0 Hz	0~100Hz	---

<Setting>

- P.251=0, no injection modeling machine function.
- P.251=1, only the flow channel is valid. Set the frequency to be completely confirmed by the flow channel input signal. The pressure channel is invalid here.
- P.251=2, only the pressure channel is valid. Set the frequency to be completely confirmed by the pressure channel input signal. The flow channel is invalid.
- P.251=3, the frequency is determined by the combination of the flow channel and the pressure channel.

Make frequency = flow channel frequency x flow channel weighted coefficient  
+ pressure channel frequency x pressure channel weighted coefficient

- P.251=4, take the maximum absolute value of the flow channel and of the pressure channel.

Set frequency = MAX (flow channel frequency and pressure channel frequency)

## Parameter Description

### Parameters

- P.254 is the corner frequency, i.e., the frequency switch point of the acceleration/deceleration time. A factory default value equals to 0 indicates the first acceleration/deceleration time P.7, P.8 used by the entire operation frequency. When P.254 is set as a certain frequency value, the output frequency is smaller than P.254. Use the first acceleration/deceleration frequency P.7 and P.8. When the output frequency is larger than P.254, use the second acceleration/deceleration time P.44, P.45.
- For more details, please refer to the instruction on PM01, the injection modeling machine specific expansion card.

## 5.63 Vibration Inhibition Factor (P.285 and P.286)

### P.285 “Low frequency vibration inhibition factor”

### P.286 “High frequency vibration inhibition factor”

Parameter	Factory setting	Setting range	Remarks
P.285	1	0~3	---
P.286	0	0~15	---

### <Setting>

1. If motor vibration is generated at lower frequency, adjust the set value of P.285. The recommended value is 1.
2. If motor vibration is generated at higher frequency, adjust the set value of P.286. Gradually increase the set value by the unit of 1.
3. For the actual application, use the vibration-generating frequency that is lower or higher than half of the motor rated frequency to determine whether the occurred vibration is a low-frequency vibration or a high-frequency vibration. That is, if the rated frequency on the name plate of the motor is 50Hz and the vibration-generating frequency is lower than 25Hz, then this is a low-frequency vibration. On the other hand, if the vibration-generating frequency is higher than 25Hz, then this is a high-frequency vibration.

Note: 1. When the motor load is light, current flow may happen at certain specific operation frequency.

This situation may cause the motor to vibrate slightly. The user can neglect it if this trivial vibration has no impact on the application.

2. If the current flow is serious (generating vibration), it may cause serious motor vibration or even inverter over-current. The user can try to adjust the vibration inhibition factor to improve the situation (Large power motors' current flow zone mostly happens at the low frequency zone).

## Parameter Description

Parameters

### 5.64 Short Circuit Protection Function (P.287)

#### P.287 "Short circuit protection function selection"

Parameter	Factory setting	Setting range	Remarks
287	1	0~1	---

#### <Setting>

- Set P.287 to 0 to cancel the output end short-circuits protection function.
- When P.287 is set to 1, if the output end is short, the operation panel will display the "SCP" abnormal alarm and the inverter will stop the output.

### 5.65 Alarm History Parameters (P.288~P.291)

#### P.288 "Alarm code display option"

#### P.289 "Alarm code"

#### P.290 "The latest alarm status selection"

#### P.291 "The latest alarm message"

- This paragraph provides the users with parameter-related information on alarm codes for frequency, current, voltage, as well as the 12 alarm codes mentioned earlier. If P.996 operation is executed, the abnormal codes and the status messages for the occurred alarms recorded by this set of parameters will be all cleared.

Parameter	Factory setting	Setting range	Remarks
288	0	0~12	The value of P.288, 1~12, corresponds to the abnormal codes of P.289's alarm E1~E12.
289	0	---	
290	0	0~7	When P.290=1, P.291 corresponds to the frequency when the alarm goes off.
291	0	---	When P.290=2, P.291 corresponds to the current when

			<p>the alarm goes off.</p> <p>When P.290=3, P.291 corresponds to the output voltage when the alarm goes off.</p> <p>When P.290=4, P.291 corresponds to the accumulation rate of temperature increase when the alarm goes off.</p> <p>When P.290=5, P.291 x 100 corresponds to the P-N voltage when the alarm goes off.</p> <p>When P.290=6, P.291 corresponds to the length of time the inverter has run before the alarm goes off.</p> <p>When P.290=7, P.291 corresponds to the operation status code when the alarm goes off.</p>
--	--	--	--

## Parameter Description

*Parameters*

If both P.288 and P.290 are 0, P.289 and P.291 will be displayed as 0.

Abnormal code corresponded alarm condition:

Abnormal code	Alarm type	Abnormal code	Alarm type	Abnormal code	Alarm type	Abnormal code	Alarm type	Abnormal code	Alarm type
00	No alarm	32	OV1	49	THN	82	IPF	144	OHT
16	OC1	33	OV2	50	NTC	97	OLS	160	OPT
17	OC2	34	OV3	64	EEP	98	OL2	179	SCP
18	OC3	35	OV0	65	FAN	112	BE	192	CPU
19	OC0	48	THT	66	PID	129	AEr	193	CPR
209	PG1	210	PG2	211	PG3				

## 5.66 Accumulative Motor Operation Time Function (P.292 and P.293)

P.292 “Accumulative motor operation time (minutes)”

P.293 “Accumulative motor operation time (days)”

Parameter	Factory setting	Setting range	Remarks
292	0 min	0~1439min	---
293	0 day	0~9999day	---

<Setting>

- P.292 is about the accumulative motor operation time in minutes. The updated value cannot be modified by executing P.998 or power shutdown. To clear the accumulated time, make P.292=0.
- P.293 is about the accumulative motor operation time in days. The updated value cannot be modified by executing P.998 or power shutdown. To clear the accumulated time, make P.293=0.

## 5.67 Password Protection Function (P.294 and P.295)

P.294 “Decryption parameter”

P.295 “Password setup”

Parameter	Factory setting	Setting range	Remarks
294	0	0~65535	---
295	0	2~65535	---

### Parameter Description

*Parameters*

<Setting>

- P.294 is the parameter that provides the decrypt function. P.294 will be zero if the decryption is successful. Use P.295 to set the password. Enter the initial password into P.294 to decrypt the parameter password and to modify or to set up various parameters.
- P.295 is the parameter for setting up the password. The password has to be greater than 1. Once the password setup is completed, P.295 will display 1. After deleting the password, P.295 will display 0. Once the password is set, no parameter can be modified, except P.294. P.998 and power shutdown have no effect on the password. The parameters can be revised only after the decryption.

Note: Bring the inverter to the factory for decryption if the password is forgotten.

## 5.68 Motor Control Mode (P.300 and P.301)

P.300 “Motor control mode selection”

P.301 “Motor parameter auto-tuning function selection”

Parameter	Factory setting	Setting range	Remarks
300	0	0~4	0   V/F control
			1   Close-loop V/F control (VF + PG)
			2   General flux vector control
			3   Sensorless vector control (SVC)
			4   Close-loop vector control (FOC + PG)
301	0	0~3	0   Parameter auto-tuning function with no motor
			1   Motor parameter auto-tuning measuring the running motor
			2   Motor parameter auto-tuning measuring the stopped motor
			3   Online auto-tuning function

## <Setting>

- When P.300=0, no motor parameter auto-tuning function is required for normal V/F curve operation.
- For general magnetic vector control, please set P.300 to 2. The frequency will be altered due to elevated voltage and increased compensatory motor load.
- For executing the motor parameter auto-tuning function, set P.301 to 1 or 2 and press the forward rotation or the reverse rotation key. During the measuring process, the operation panel will flicker and display "TUN". If the measurement fails, the operation panel will flicker "FAL" for three seconds and then return to normal display.

## Parameter Description

- Procedures for motor parameter auto-tuning are presented below:

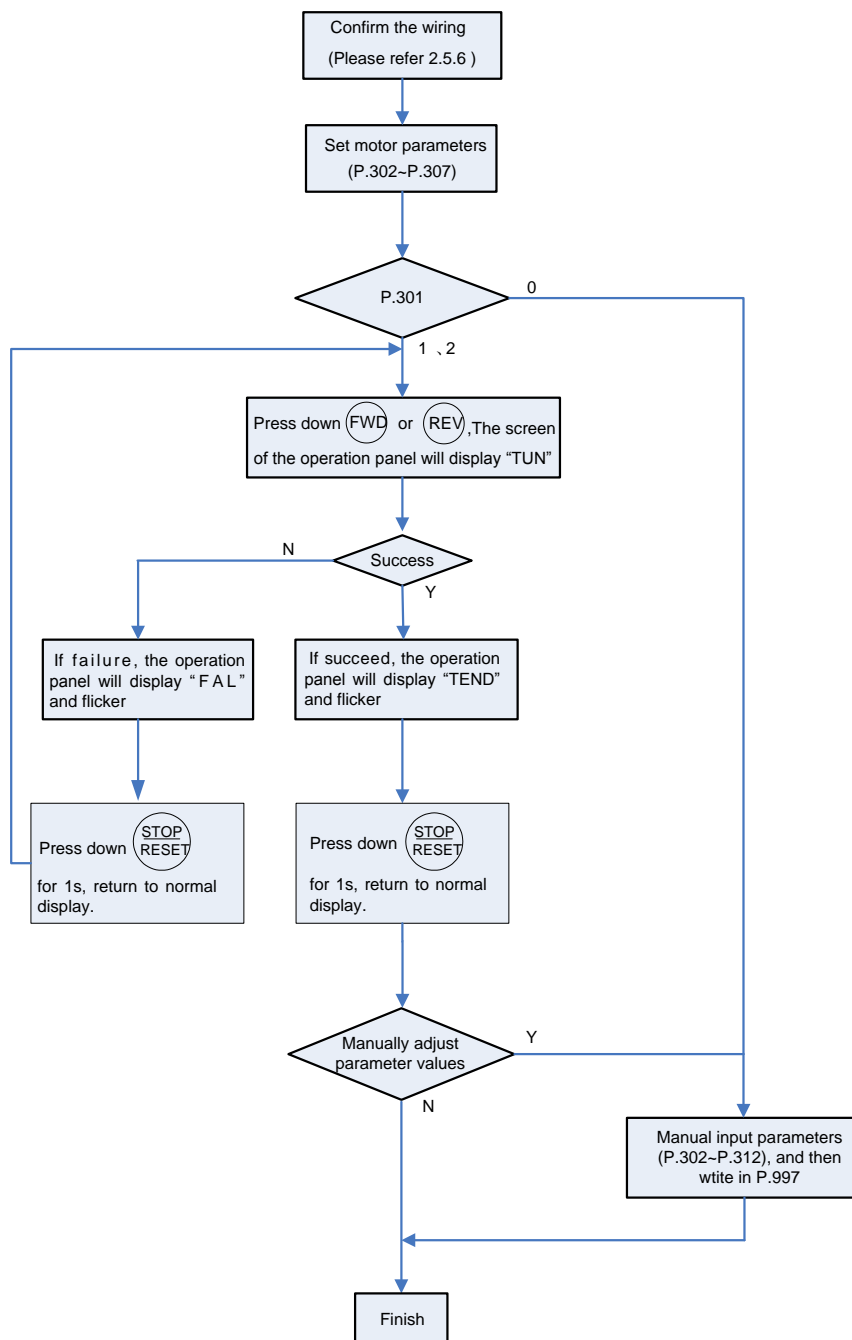

- If high accuracy sensorless control is required, set P.300 to 3 for sensorless vector control.

Note: 1. The motor capacity has to be at the same level or one level below of the level of the capacity of the inverter.

2. For the auto-tuning function, if motor operation is permitted, set P.301 to 1 (dynamic measurement). At this point, the load has to be separated from the motor. If the load environment does not permit auto-tuning, set P.301 to 2 (static measurement) if motoring is running.

3. Sensorless vector control: Auto-tuning function can be used to enhance the control function. Before setting P.300 to 3 or 4, first set the motor parameters or the auto-tuning function to improve the control accuracy.

## Parameter Description

*Parameters*

### 5.69 Motor Parameter (P.302~P.312)

P.302 “Motor rated power”

P.308 “Motor excitation current”

P.303 “Motor poles”

P.309 “Stator resistance”

P.304 “Motor rated voltage”

P.310 “Rotor resistance”

P.305 “Motor rated frequency”

P.311 “Leakage inductance”



P.306 “Motor rated voltage”



P.312 “Mutual inductance”

P.307 “Motor rated rotation speed”

Parameter	Factory setting	Setting range	Remarks
302	0	0~160	---
303	4	0~8	---
304	220/440V	0~440V	---
305	50Hz	0~400Hz	<u>P.189</u> =1
	60Hz		P.189=0
306	Horsepower-based	0~500A	---
307	1410 r/min	0~65535 r/min	P.189=1
	1710 r/min		P.189=0
308	Horsepower-based	0~500A	---
309	Horsepower-based	0~65535mΩ	---
310	Horsepower-based	0~65535mΩ	---
311	Horsepower-based	0~6553.5mH	---
312	Horsepower-based	0~6553.5mH	---

### <Setting>

- When the motor can be fully separated from the load, select P.301=1. When the motor is running, the motor parameter will carry out auto-tuning. Then press  or  on the keyboard panel for the inverter to automatically calculate the following parameter: P.308~P.312.
- When the motor cannot be fully separated from the load, select P.301=2. When the motor is

stopped, the motor parameter will carry out auto-tuning. Then press  or  on the keyboard panel for the inverter to automatically calculate the following parameter: P.308~P.312.

- The users can use the motor's nameplate to calculate the two parameters. The motor nameplate parameters used in the calculation are: rated voltage U, rated current I, rated frequency  $f$  and power factor  $\eta$ .

## Parameter Description

### Parameters

- The calculation of motor idling excitation current and of motor mutual induction is presented below:  $L_6$  is motor leakage induction.

Idling current:  $I_0 = I \times \sqrt{1 - \eta^2}$

Mutual inductance calculation:  $L_m = \frac{U}{2\sqrt{3} \cdot \pi \cdot f \cdot I_0} - L_6$

$I_0$  is the idling current, whereas  $L_m$  is mutual inductance,  $L_6$  is leakage inductance.

Note: 1. When the inverter is used with a motor of a different level, verify the input motor's nameplate parameter P.302~P.307. The vector control method is heavily dependent upon motor parameters. To achieve a good control performance, the controlled motor's correct parameters have to be acquired.

2. When any or many values of P.302~P.312 are manually revised, perform the function of [P.997](#) to reload the new values of the parameters.

## 5.70 Gain Adjustment at Speed Control (P.320~P.321)

### P.320 "Speed control proportion coefficient"

### P.321 "Speed control integral coefficient"

Parameter	Factory setting	Setting range	Remarks
320	100%	0~2000%	---
321	0.30s	0~20s	---

#### <Setting>

- P.320 is used to set the proportion gain of speed control. (Set the value slightly larger to better follow changes on the speed command and to reduce speed change due to external interference.)
- P.321 is used to set the integral time of speed control. (Due to external interference-generated speed change, set the value smaller to shorten the time spent on returning to the original speed).

Note: 1. Use P.320 to increase the set value of speed control gain can elevate the effecting time. But a set value too high can generate vibration and noises.

2. Reduce speed control integral coefficient P.321 to shorten the time required to go back to the original speed. But if the value is too small, overshoot can happen.

## Parameter Description

Parameters

### 5.71 Feedback Control Parameters (P.350~P.354)

P.350 “Number of pulses per revolution of the encoder”

P.351 “Encoder input mode setup”

P.352 “PG signal abnormality (zero speed) detection time”

P.353 “Motor over-speed detection frequency”

P.354 “PG over-speed detection time”

Parameter	Factory setting	Setting range	Remarks
P.350	1024	1~20000	---
P.351	0	0~4	---
P.352	1s	0~100s	---
P.353	4Hz	0~30Hz	---
P.354	1s	0~100s	---

#### <Setting>

- When using the PG card, P.350 is applied for setting up the number of pulses to be generated by the encoder per revolution of the motor. That is, the number of pulses generated by one cycle of Phase A/Phase B. When carrying out PG feedback control, if the detected frequency is 0, and with duration longer than the time set by P.352, and then the PG card’s feedback signal is abnormal. The inverter will display alarm PG2 and stop the operation. If PG signal abnormal (zero speed) detection time P.352 is set to 0, then there is no PG card feedback signal abnormal function, i.e., no alarm PG2.
- When carrying out PG feedback control, if the difference between the detected frequency and the output frequency exceeds P.353, and with duration longer than the set time of P.354, then the speed deviation is too big. The inverter will display alarm PG3 and stop the operation. If PG over-speed detection time P.354 is set to 0, then alarm PG3 function is not available.
- P.351 is applied for setting up the encoder’s input mode. The following encoder input modes are used as some examples:
  - 0: No function;
  - 1: Phase A/B pulse train, Phase A is 90° ahead of Phase B and is forward rotation.

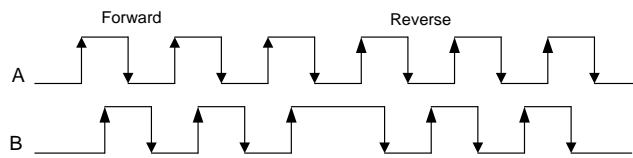

2: Phase A/B pulse train, Phase B is 90° ahead of Phase A and is forward rotation.

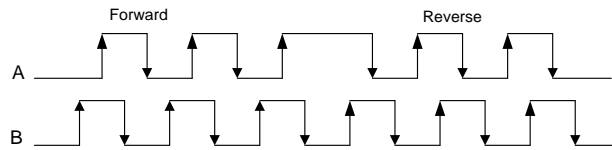

## Parameter Description

Parameters

3. Phase A is a pulse train. Phase B is a direction sign. L is reverse rotation and H is forward rotation

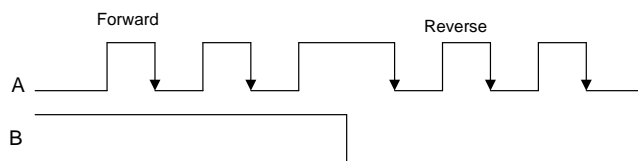

4. Phase A is a pulse train. Phase B is a direction sign. L is forward rotation and H is reverse rotation.

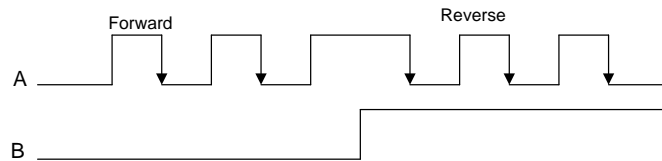

Note: 1. If closed-loop control is selected but P.351=0, then the inverter will display alarm PG1 and stop the operation.

2. When P.300=1, execute the V/F closed-loop control; when P.300=4, execute the closed-loop vector control.

3. When P.151=1, zero-speed operation is executed under the closed-loop control; DC voltage brake is executed under the V/F closed-loop control.

## 5.72 Parameter Copy Function (P.994 and P.995) (a PU series operation panel needs to be purchased)

### P.994 "Parameter copy readout"

### P.995 "Parameter copy write-in"

- Parameter copy function is valid only when the motor is stop, P.77=0, and under the PU mode. When several inverters use the same parameters value, only by setting one inverter that we can use P.994 and P.995 to quickly copy the values to other inverters.
- Parameter copy operation procedure:
  1. When the first inverter is in the PU mode, the value of P.994 is readout (the screen will

display  $P.r.L.P$ ) and then written-in. The screen will then start to flicker, indicating that the parameters are copied from the inverter to the operation panel. When the flickering on the screen is stopped, parameter copying is completed.

2. When the second inverter is in the PU mode, the value of P.995 is readout (the screen will display  $P.r.L.P$ ) and then written-in. The screen will then start to flicker, indicating that the parameters are copied from the control panel to the inverter. When the flickering on the screen is stopped, parameter copying is completed.

## Parameter Description

### Parameters

- Note: 1. Regarding the parameter copy function of SF-Type inverters, it is limited to inverters of version V0.80 or above, or PU01 operation panel of version V2.05 or above.
2. If the version of the inverter is updated, pick inverter parameters of the lower version inverter among inverters of different versions for parameter copying.
  3. Parameters cannot be copied between inverters of different series.
  4. When parameters cannot be copied, PU01 operation panel will display the alarm code “OPT” or “Err”. These alarm codes are not the abnormal alarm codes. When these alarm codes are displayed, inverter reset is not required.
  5. Please refer to the PU01 operation manual for more details.

### 5.73 Alarm History Clear (P.996)

#### P.996 “Alarm history clear”

- Once P.996 is read-out (after reading out the parameter, the screen will display  $E.r.L.L$ ) and rewrite it. All the abnormal record will be erased.

### 5.74 Inverter Reset (P.997)

#### P.997 “Inverter reset”

- Once P.997 is read-out (after the read-out, the screen will display  $r.E.S.r$ ) and rewritten-in, the inverter is reset. After resetting the inverter, the values of the two relays, “electronic thermal relay” and “IGBT module thermal relay”, will be set to zero.

### 5.75 Restoration of the Parameters to the Default Values (P.998 and P.999)

#### P.998 “Restoring all parameters to default values”

#### P.999 “Restoring some parameters to default values”

- Once P.998 is read-out (after the read-out, the screen will display  $\overline{ALL}$ ) and rewritten-in, all the parameters will be restored to the default values except P.21, P.186, P.188, P.189, P.285, P.286, P.292 and P.293.
- Once P.999 is read-out (after the read-out, the screen will display  $\overline{Pr}$ ) and rewritten-in, all the parameters will be restored to the default values except P.21, P.186, P.188, P.189, P.190, P.191, P.192~P.195, P.196~P.199, P.285, P.286, P.292, P.293 and P.300~P.312.
- After performing P.998 and P.999, the screen will display  $\overline{0.0}$ , indicating that the parameters have been restored to the default values.

## 6. Inspection and Maintenance

In order to avoid malfunction and security problems resulting from device aging caused by environmental factors such as temperature, oil fog, dust, vibration, humidity and etc., “daily inspection” and “periodical inspection” are necessary.

Note: The installation, wire arrangement, dismounting, and maintenance can only be done by qualified electricians.

### 6.1 Daily Inspection

---

1. Check whether the surrounding conditions are normal (including temperature, humidity, dust density, etc.) at the place of the installation.
2. Check whether the power supply voltage is normal (the voltage between R/L1, S/L2 and T/L3).
3. Check whether the wiring is secured (whether the external wiring for the main-circuit board and the control-board terminal are secured).
4. Check whether the cooling system is normal (whether there's any abnormal noise during the operation and whether the wiring is well secured).
5. Check whether the indicator lamp is normal (whether the indicator lamp of the control board and of the operation panel and the LED monitor of the operation panel are normal).
6. Check whether the operation is as expected.
7. Check whether there is any abnormal vibration, noise or odor during the operation.
8. Check whether there is any leakage from the filter capacitor.

### 6.2 Periodical Inspection (During Machine Shutdown) Items

---

1. Check the connectors and wiring (whether the connectors and wiring between the main-circuit board and control board are secured and without damage).
2. Check whether the components on the main-circuit board and the control board are overheated.
3. Check whether the electrolytic capacitors on the main-circuit board and control board have leakage.
4. Check the IGBT module on the main-circuit board.
5. Clean the dust and foreign substance on the circuit board.
6. Check the insulation resistor.
7. Check whether the cooling system is normal (whether the wiring is secured; clean the air filter, etc.)
8. Check the screws and belts.
9. Check the external wires and the terminal banks for damage.

## 6.3 Regular Replacement for Some Components

Items	Standard replacing time	Description
Cooling fan	2 years	For the axle of a fan, the standard lifetime is about 10 – 35 thousand hours. Assuming that the fan operates 24 hours per day, the fan should be replaced every 2 years.
Filter capacitor	5 years	The filter capacitor is an electrolytic capacitor that deteriorates with time. The deterioration speed is contingent on the ambient conditions. Generally, it should be replaced every 5 years.
Relay	---	If bad contact occurs, please replace it immediately.

Note: please send the inverters to the factory fore complement replacement.

## 6.4 Inverter Insulation Resistance Measurement

1. Before measuring the inverter insulation resistance, first dismount the “wiring of all the main-circuit terminals” and the “control board.” Then execute the wiring as shown in the right picture.
2. The measurement is only suitable for the main circuit. It is prohibited to use a high-resistance meter for measuring terminals on the control board.
3. The value of the insulation resistance shall be greater than 5MΩ.

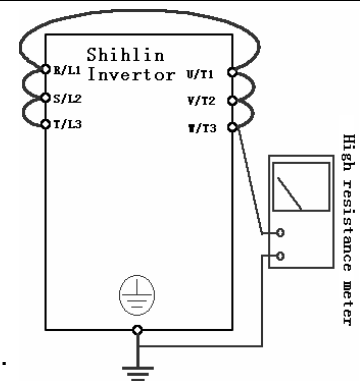

Note: Please do not carry out a high-voltage test; as such test will damage the built-in semiconductor components.

## 6.5 Motor Insulation Resistance Measurement

1. Before the measurement, please dismount the motor, and execute the wiring as shown in the diagram on the right.
2. The value of the insulation resistance shall be greater than 5MΩ.

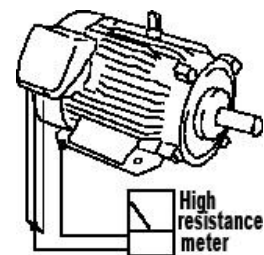

## 6.6 IGBT Module Test

Before conducting the IGBT module test, first dismantle the external wires from the main-circuit terminals. Then set the multi-meter to the ohm-testing position.

	Positive voltage	Negative voltage	Normal result		Positive voltage	Negative voltage	Normal result
Terminal mark	R	P	Conductive	Terminal mark	U	P	Conductive
	S	P	Conductive		V	P	Conductive
	T	P	Conductive		W	P	Conductive
	P	R	Non-conductive		P	U	Non-conductive
	P	S	Non-conductive		P	V	Non-conductive
	P	T	Non-conductive		P	W	Non-conductive
	R	N	Non-conductive		U	N	Non-conductive
	S	N	Non-conductive		V	N	Non-conductive
	T	N	Non-conductive		W	N	Non-conductive
	N	R	Conductive		N	U	Conductive
	N	S	Conductive		N	V	Conductive
	N	T	Conductive		N	W	Conductive

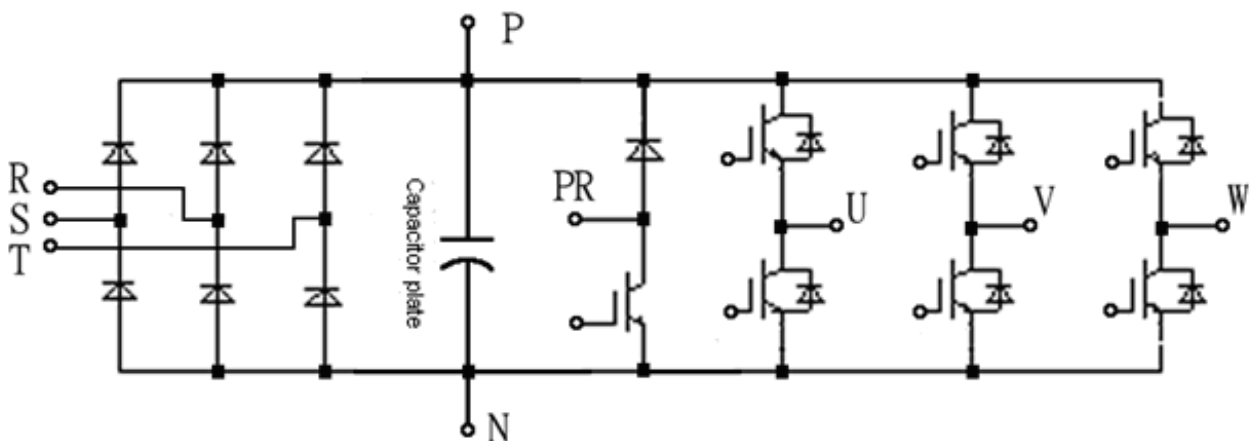

Note: The above diagram is the schematic diagram for frame A and B.

# Appendix 1 Parameter Table

Parameter Number	Name	Setting Range	Minimum Setting Unit	Default Value	User Setting Value	Reference Page
<u>P.0</u>	Torque boost	0~30%	0.1%	Model-based (Note 1)		P47
<u>P.1</u>	Maximum frequency	0~120Hz	0.01Hz	120Hz (55kW or below) 60Hz (75kW or above)		P48
<u>P.2</u>	Minimum frequency	0~120Hz	0.01Hz	0Hz		P48
<u>P.3</u>	Base frequency	0~400Hz	0.01Hz	50Hz/60Hz (Note 2)		P48
<u>P.4</u>	Speed 1 (high speed)	0~400Hz	0.01Hz	60Hz		P49
<u>P.5</u>	Speed 2 (medium speed)	0~400Hz	0.01Hz	30Hz		P49
<u>P.6</u>	Speed 3 (low speed)	0~400Hz	0.01Hz	10Hz		P49
<u>P.7</u>	Acceleration time	0~360s/ 0~3600s	0.01s/0.1s	20s		P51
<u>P.8</u>	Deceleration time	0~360s/ 0~3600s	0.01s/0.1s	10s (7.5kW or below) 30s (11kW or above)		P51
<u>P.9</u>	Electronic thermal relay capacity	0~500A	0.01A	Motor rated current (Note 1)		P52
<u>P.10</u>	DC injection brake operation frequency	0~120Hz	0.01Hz	3Hz		P53
<u>P.11</u>	DC injection brake operation time	0~60s	0.1s	0.5s		P53
<u>P.12</u>	DC injection brake operation voltage	0~30%	0.1%	4% (7.5kW or below) 2% (11kW~55kW) 1% (75kW or above)		P53
<u>P.13</u>	Starting frequency	0~60Hz	0.01Hz	0.5Hz		P54
<u>P.14</u>	Load pattern selection	0~13	1	0		P54
<u>P.15</u>	JOG frequency	0~400Hz	0.01Hz	5Hz		P57
<u>P.16</u>	JOG acceleration /deceleration time	0~360s/ 0~3600s	0.01s/0.1s	0.5s		P57
<u>P.17</u>	Reserved					
<u>P.18</u>	High speed maximum frequency	120~400Hz	0.01Hz	120Hz		P48

# Appendix 1 Parameter Table

Parameter Table

Parameter Number	Name	Setting Range	Minimum Setting Unit	Default Value	User Setting Value	Reference Page
<u>P.19</u>	Base frequency voltage	0~1000V, 99999	0.1V	99999		P48
<u>P.20</u>	Acceleration / deceleration reference frequency	1~400Hz	0.01Hz	50Hz/60Hz (Note 2)		P51
<u>P.21</u>	Acceleration/ deceleration time increments	0, 1	1	0		P51
<u>P.22</u>	Stall prevention operation level	0~400%	0.1%	120%/150% (Note 3)		P57
<u>P.23</u>	Compensation factor at level reduction	0~150%, 99999	0.1%	99999		P57
<u>P.24</u>	Speed 4	0~400Hz, 99999	0.01Hz	99999		P49
<u>P.25</u>	Speed 5	0~400Hz, 99999	0.01Hz	99999		P49
<u>P.26</u>	Speed 6	0~400Hz, 99999	0.01Hz	99999		P49
<u>P.27</u>	Speed 7	0~400Hz, 99999	0.01Hz	99999		P49
<u>P.28</u>	Output frequency filter constant	0~31	1	0		P59
<u>P.29</u>	Acceleration/ deceleration curve selection	0, 1, 2	1	0		P59
<u>P.30</u>	Regenerative brake function selection	0, 1	1	0		P61
<u>P.31</u>	Soft-PWM selection	0, 1	1	0		P61
<u>P.32</u>	Serial communication Baud rate selection	0, 1, 2, 3	1	1		P62
<u>P.33</u>	Communication protocol selection	0, 1	1	1		P62
P.34	Reserved					
P.35	Reserved					
<u>P.36</u>	Inverter station number	0~254	1	0		P62
<u>P.37</u>	Speed display	0~5000r/min	0.1 r/min	0 r/min		P79
<u>P.38</u>	The maximum operation frequency (the target frequency is set by the input signal of terminal 2-5)	1~400Hz	0.01Hz	50Hz/60Hz (Note 2)		P80

# Appendix 1 Parameter Table

Parameter Number	Name	Setting Range	Minimum Setting Unit	Default Value	User Setting Value	Reference Page
<a href="#">P.39</a>	The maximum operation frequency (the target frequency is set by the input signal of terminal 4-5)	1~400Hz	0.01Hz	50Hz/60Hz (Note 2)		P84
<a href="#">P.40</a>	Multi-function output terminal SU function selection	0~15	1	1		P84
<a href="#">P.41</a>	Up-to-frequency sensitivity	0~100%	0.1%	10%		P86
<a href="#">P.42</a>	Output frequency detection for forward rotation	0~400Hz	0.01Hz	6Hz		P87
<a href="#">P.43</a>	Output frequency detection for reverse rotation	0~400Hz, 99999	0.01Hz	99999		P87
<a href="#">P.44</a>	The second acceleration time	0~360s/ 0~3600s, 99999	0.01s/0.1s	99999		P51
<a href="#">P.45</a>	The second deceleration time	0~360s/ 0~3600s, 99999	0.01s/0.1s	99999		P51
<a href="#">P.46</a>	The second torque boost	0~30%, 99999	0.1%	99999		P47
<a href="#">P.47</a>	The second base frequency	0~400Hz, 99999	0.01Hz	99999		P48
<a href="#">P.48</a>	Data length	0, 1	1	0		P62
<a href="#">P.49</a>	Stop bit length	0, 1	1	0		P62
<a href="#">P.50</a>	Parity check selection	0, 1, 2	1	0		P62
<a href="#">P.51</a>	CR & LF selection	1, 2	1	1		P62
<a href="#">P.52</a>	Number of communication retries	0~10	1	1		P62
<a href="#">P.53</a>	Communication check time interval	0~999.8s, 99999	1s	99999		P62
<a href="#">P.54</a>	FM/AM terminal function selection	0~4	1	0		P88
<a href="#">P.55</a>	Frequency display reference	0~400Hz	0.01Hz	50Hz/60Hz (Note 2)		P88
<a href="#">P.56</a>	Current monitoring reference	0~500A	0.01A	Rated output current		P88
<a href="#">P.57</a>	Restart coasting time	0~30s, 99999	0.1s	99999		P90

# Appendix 1 Parameter Table

Parameter Table

Parameter Number	Name	Setting Range	Minimum Setting Unit	Default value	User Setting Value	Reference Page
P.58	Restart cushion time	0~60s	0.1s	5s (7.5kW or below)		P90
				10s (11kW~55kW)		
				20s (75kW or above)		
P.59	Reserved					
P.60	Input signal filter constant	0~31	1	31		P91
P.61	Remote setting function selection	0~3	1	0		P91
P.62	Zero current detection level	0~200%, 99999	0.1%	5%		P94
P.63	Zero current detection time	0.05~1s, 99999	0.01s	0.5s		P94
P.64	FM/AM output terminal selection	0, 1	1	0		P88
P.65	Retry selection	0~4	1	0		P94
P.66	Stall prevention operation reduction starting frequency	0~400Hz	0.01Hz	50Hz/60Hz (Note 2)		P57
P.67	Number of retries at alarm occurrence	0~10	1	0		P94
P.68	Retry waiting time	0~360s	0.1s	1s		P94
P.69	Retry accumulation time at alarm	0	0	0		P94
P.70	Special regenerative brake duty	0~30%	0.1%	0		P61
P.71	Idling braking and linear braking selection	0, 1	1	1		P96
P.72	Carrier frequency	7.5kW or below :0.7~10 kHz	0.1kHz	7.5kW or below: 5 kHz		P96
		11~22kW: 0.7~9 kHz		11~22kW: 5 kHz		
		30~90kW: 0.7~6 kHz		30~90kW: 4 kHz		
		110~160kW :0.7~6 kHz		110~160kW: 2 kHz		
P.73	Voltage signal selection	0, 1	1	0		P80
P.74	FU/10X output terminal selection	0~10	1	0		P97

# Appendix 1 Parameter Table

Parameter Number	Name	Setting Range	Minimum Setting Unit	Default value	User Setting Value	Reference Page
<u>P.75</u>	Stop or reset function selection	0~1	1	1		P98
P.76	Reserved					
<u>P.77</u>	Parameters write protection	0, 1, 2	1	0		P98
<u>P.78</u>	Forward/reverse rotation prevention selection	0, 1, 2	1	0		P99
<u>P.79</u>	Operation mode selection	0~8	1	0		P99
<u>P.80</u>	Multi-function terminal RL function selection	0~39	1	2		P100
<u>P.81</u>	Multi-function terminal RM function selection	0~39	1	3		P100
<u>P.82</u>	Multi-function terminal RH function selection	0~39	1	4		P100
<u>P.83</u>	Multi-function terminal STF function selection	0~39	1	0		P100
<u>P.84</u>	Multi-function terminal STR function selection	0~39	1	1		P100
<u>P.85</u>	Function selection for multi-function relay	0~15	1	5		P84
<u>P.86</u>	Multi-function terminal RES function selection	0~39	1	30		P100
P.87	Reserved					
P.88	Reserved					
<u>P.89</u>	Slip compensation coefficient	0~10	1	0		P105
P.90	Reserved					
<u>P.91</u>	Frequency jump 1A	0~400Hz, 99999	0.01Hz	99999		P105
<u>P.92</u>	Frequency jump 1B	0~400Hz, 99999	0.01Hz	99999		P105
<u>P.93</u>	Frequency jump 2A	0~400Hz, 99999	0.01Hz	99999		P105
<u>P.94</u>	Frequency jump 2B	0~400Hz, 99999	0.01Hz	99999		P105
<u>P.95</u>	Frequency jump 3A	0~400Hz, 99999	0.01Hz	99999		P105
<u>P.96</u>	Frequency jump 3B	0~400Hz, 99999	0.01Hz	99999		P105
P.97	Reserved					
<u>P.98</u>	Middle frequency 1	0~400Hz	0.01Hz	3Hz		P54

# Appendix 1 Parameter Table

Parameter Number	Name	Setting Range	Minimum Unit	Default value	User Setting Value	Reference Page
<u>P.99</u>	Output voltage 1 of middle frequency	0~100%	0.1	10%		P54
<u>P.100</u>	Minute/second selection	0, 1	1	1		P106
<u>P.101</u>	Runtime of Section 1 in programmed operation mode	0~6000s	0.1s	0s		P106
<u>P.102</u>	Runtime of Section 2 in programmed operation mode	0~6000s	0.1s	0s		P106
<u>P.103</u>	Runtime of Section 3 in programmed operation mode	0~6000s	0.1s	0s		P106
<u>P.104</u>	Runtime of Section 4 in programmed operation mode	0~6000s	0.1s	0s		P106
<u>P.105</u>	Runtime of section 5 in programmed operation mode	0~6000s	0.1s	0s		P106
<u>P.106</u>	Runtime of section 6 in programmed operation mode	0~6000s	0.1s	0s		P106
<u>P.107</u>	Runtime of Section 7 in programmed operation mode	0~6000s	0.1s	0s		P106
<u>P.108</u>	Runtime of Section 8 in programmed operation mode	0~6000s	0.1s	0s		P106
<u>P.110</u>	Operation panel monitoring selection	0, 1, 2	1	1		P108
<u>P.111</u>	Acceleration/deceleration time of section 1	0~600s /0~6000s	0.01s/0.1s	0s		P106
<u>P.112</u>	Acceleration/deceleration time of section 2	0~600s /0~6000s	0.01s/0.1s	0s		P106
<u>P.113</u>	Acceleration/deceleration time of Section 3	0~600s /0~6000s	0.01s/0.1s	0s		P106
<u>P.114</u>	Acceleration/deceleration time of Section 4	0~600s /0~6000s	0.01s/0.1s	0s		P106
<u>P.115</u>	Acceleration/deceleration time of Section 5	0~600s /0~6000s	0.01s/0.1s	0s		P106
<u>P.116</u>	Acceleration/deceleration time of Section 6	0~600s /0~6000s	0.01s/0.1s	0s		P106
<u>P.117</u>	Acceleration/deceleration time of Section 7	0~600s /0~6000s	0.01s/0.1s	0s		P106
<u>P.118</u>	Acceleration/deceleration time of Section 8	0~600s /0~6000s	0.01s/0.1s	0s		P106

# Appendix 1 Parameter Table

Parameter Number	Name	Setting Range	Minimum Unit	Default value	User Setting Value	Reference Page
P.119	Reserved					
<u>P.120</u>	Output signal delay time	0~3600s	0.1s	0s		P84
<u>P.121</u>	Run direction in each section	0~255	1	0		P106
<u>P.122</u>	Cycle selection	0~8	1	0		P106
<u>P.123</u>	Acceleration/deceleration time setting selection	0, 1	1	0		P106
P.125	Reserved					
<u>P.126</u>	Multi-function terminal AU function selection	0~39	1	5		P100
<u>P.127</u>	Multi-function terminal RT function selection	0~39	1	8		P100
<u>P.128</u>	Multi-function terminal MRS function selection	0~39	1	7		P100
<u>P.129</u>	Multi-function terminal RUN function selection	0~15	1	0		P84
<u>P.130</u>	Multi-function terminal FU/10X function selection	0~15	1	2		P84
<u>P.131</u>	Frequency of section 1	0~400Hz	0.01Hz	0Hz		P106
<u>P.132</u>	Frequency of section 2	0~400Hz	0.01Hz	0Hz		P106
<u>P.133</u>	Frequency of section 3	0~400Hz	0.01Hz	0Hz		P106
<u>P.134</u>	Frequency of section 4	0~400Hz	0.01Hz	0Hz		P106
<u>P.135</u>	Frequency of section 5	0~400Hz	0.01Hz	0Hz		P106
<u>P.136</u>	Frequency of section 6	0~400Hz	0.01Hz	0Hz		P106
<u>P.137</u>	Frequency of section 7	0~400Hz	0.01Hz	0Hz		P106
<u>P.138</u>	Frequency of section 8	0~400Hz	0.01Hz	0Hz		P106
<u>P.139</u>	Voltage signal bias	0~100%	0.1%	0%		P80
<u>P.140</u>	Voltage signal gain	0.1~200%	0.1%	100%		P80
<u>P.141</u>	Voltage signal bias direction and rotational direction setup	0~11	1	0		P80
<u>P.142</u>	Speed 8	0~400Hz 99999	0.01Hz	0Hz		P49
<u>P.143</u>	Speed 9	0~400Hz, 99999	0.01Hz	99999		P49
<u>P.144</u>	Speed 10	0~400Hz, 99999	0.01Hz	99999		P49

# Appendix 1 Parameter Table

Parameter Number	Name	Setting Range	Minimum Unit	Default Value	User Setting Value	Reference Page
<a href="#">P.145</a>	Speed 11	0~400Hz, 99999	0.01Hz	99999		P49
<a href="#">P.146</a>	Speed 12	0~400Hz, 99999	0.01Hz	99999		P49
<a href="#">P.147</a>	Speed 13	0~400Hz, 99999	0.01Hz	99999		P49
<a href="#">P.148</a>	Speed 14	0~400Hz, 99999	0.01Hz	99999		P49
<a href="#">P.149</a>	Speed 15	0~400Hz, 99999	0.01Hz	99999		P49
<a href="#">P.150</a>	Restart mode selection	0~221	1	0		P90
<a href="#">P.151</a>	Zero-speed control function selection	0, 1	1	0		P109
<a href="#">P.152</a>	Voltage instruction at zero-speed control	0~30%	0.1%	4% (7.5kW or below)		P109
				2% (11kW~55kW)		
				1% (75kW or above)		
<a href="#">P.153</a>	Communication error handling	0, 1	1	0		P62
<a href="#">P.154</a>	Modbus communication data format	0~5	1	4		P62
<a href="#">P.155</a>	Over-torque detection level	0~200%	0.1%	0%		P109
<a href="#">P.156</a>	Over-torque detection time	0.1~60s	0.1s	1s		P109
<a href="#">P.157</a>	External terminals filter adjusting function	0~200	1	4		P110
<a href="#">P.158</a>	External terminal power enable	0, 1	1	0		P111
<a href="#">P.159</a>	Energy-saving control function	0, 1	1	0		P111
<a href="#">P.160</a>	Stall prevention operation level when restart	0~150%	0.1%	100%		P90
<a href="#">P.161</a>	Multi-function display selection	0~11	1	0		P112
<a href="#">P.162</a>	Middle frequency 2	0~400Hz, 99999	0.01Hz	99999		P54
<a href="#">P.163</a>	Output voltage 2 of middle frequency	0~100%	0.1	0		P54

# Appendix 1 Parameter Table

Parameter Number	Name	Setting Range	Minimum Unit	Default Value	User Setting Value	Reference Page
P.164	Middle frequency 3	0~400Hz, 99999	0.01Hz	99999		P54
P.165	Output voltage 3 of middle frequency	0~100%	0.1	0		P54
P.166	Middle frequency 4	0~400Hz, 99999	0.01Hz	99999		P54
P.167	Output voltage 4 of middle frequency	0~100%	0.1	0		P54
P.168	Middle frequency 5	0~400Hz, 99999	0.01Hz	99999		P54
P.169	Output voltage 5 of middle frequency	0~100%	0.1	0		P54
P.170	PID function selection	0, 1, 2	1	0		P113
P.171	PID feedback control method selection	0, 1	1	0		P113
P.172	PID proportion Gain	1~100	1	20		P113
P.173	PID integration Gain	0~100s	0.1s	1s		P113
P.174	PID differential Gain	0~1000ms	1ms	0ms		P113
P.175	Abnormal deviation level	0~100%	0.1%	0		P113
P.176	Exception duration time	0~600s	0.1s	30s		P113
P.177	Exception handling mode	0, 1, 2	1	0		P113
P.178	Sleep detects deviation	0~100%	0.1%	0		P113
P.179	Sleep detects duration time	0~255s	0.1s	1s		P113
P.180	Revival level	0~100%	0.1%	90%		P113
P.181	Outage level	0~120Hz	0.01Hz	40Hz		P113
P.182	Integral upper limit frequency	0~120Hz	0.01Hz	50Hz/60Hz (Note 2)		P113
P.183	Deceleration step length with stable pressure	0~10Hz	0.01Hz	0.5Hz		P113
P.184	4-5 terminal disconnection handling	0~3	1	0		P116
P.186	SF-G model selection function	0, 1	1	0		P117
P.187	FM calibration parameter	0~9998	1	166		P88
P.188	Firmware version	---	---	---		P117
P.189	Factory setting function	0, 1	1	60Hz System	0	P117
				50Hz System	1	
P.190	AM output bias	0~1400	1	0 (Note 4)		P88

# Appendix 1 Parameter Table

Parameter Number	Name	Setting Range	Minimum Unit	Default value	User Setting Value	Reference Page
<a href="#">P.191</a>	AM output gain	0~1400	1	600 (Note 4)		P88
<a href="#">P.192</a>	2-5 terminal minimum input voltage	0~10	0.01	0		P118
<a href="#">P.193</a>	2-5 terminal maximum input voltage	0~10	0.01	0		P118
<a href="#">P.194</a>	Frequency corresponds to the minimum input voltage of terminal 2-5	0~60Hz	0.01Hz	0Hz		P118
<a href="#">P.195</a>	Frequency corresponds to the maximum input voltage of terminal 2-5	0~400Hz	0.01Hz	50Hz/60Hz (Note 2)		P118
<a href="#">P.196</a>	4-5 terminal minimum input current corresponded frequency	0~60Hz	0.01Hz	0Hz		P119
<a href="#">P.197</a>	4-5 terminal maximum input current corresponded frequency	0~400Hz	0.01Hz	50Hz/60Hz (Note 2)		P119
<a href="#">P.198</a>	4-5 terminal minimum input current	0~20	0.01	0		P119
<a href="#">P.199</a>	4-5 terminal maximum input current	0~20	0.01	0		P119
<a href="#">P.200</a>	Constant pressure system function selection	0~14	1	0		P121
<a href="#">P.209</a>	Maximum frequency duration	0.1~10min	0.1min	5min		P121
<a href="#">P.210</a>	Minimum frequency duration	0.1~10min	0.1min	5min		P121
<a href="#">P.213</a>	Acceleration time for starting the commercial power supply frequency	0.01~20s /0.1~200s	0.01s /0.1 s	5s		P121
<a href="#">P.214</a>	Deceleration time for starting the commercial power supply frequency	0.01~20s /0.1~200s	0.01s /0.1 s	5s		P121
<a href="#">P.215</a>	Maximum frequency	20~60Hz	0.01Hz	50Hz		P121
<a href="#">P.216</a>	Minimum frequency	0~20Hz	0.01Hz	20Hz		P121
<a href="#">P.217</a>	Motor switchover permitted deviation	0~20%	0.1%	0		P121
<a href="#">P.223</a>	Analog feedback bias pressure	0~100%	0.1	0%		P121
<a href="#">P.224</a>	Analog feedback gain pressure	0~100%	0.1	100%		P121
<a href="#">P.225</a>	Panel command	0~100%, 99999	0.1	20%		P121
<a href="#">P.229</a>	Backlash compensation function selection	0~1	1	0		P124

# Appendix 1 Parameter Table

Parameter Number	Name	Setting Range	Minimum Unit	Default value	User Setting Value	Reference Page
<u>P.230</u>	The backlash compensation acceleration interrupt frequency	0~400Hz	0.01Hz	1Hz		P124
<u>P.231</u>	The backlash compensation acceleration interrupt time	0~360 s	0.1s	0.5s		P124
<u>P.232</u>	The backlash compensation deceleration interrupt frequency	0~400Hz	0.01Hz	1Hz		P124
<u>P.233</u>	The backlash compensation deceleration interrupt time	0~360 s	0.1s	0.5s		P124
<u>P.234</u>	Triangular wave function selection	0~2	1	0		P125
<u>P.235</u>	Maximum amplitude	0~25%	0.1%	10%		P125
<u>P.236</u>	Amplitude compensation for deceleration	0~50%	0.1%	10%		P125
<u>P.237</u>	Amplitude compensation for acceleration	0~50%	0.1%	10%		P125
<u>P.238</u>	Amplitude acceleration time	0~360s /0~3600 s	0.01s/0.1s	10s		P125
<u>P.239</u>	Amplitude deceleration time	0~360s /0~3600 s	0.01s/0.1s	10s		P125
<u>P.240</u>	Auxiliary frequency function selection	0~4	1	0		P126
<u>P.242</u>	DC injection brake function before starting selection	0~1	1	0		P126
<u>P.243</u>	DC injection brake time before starting	0~60s	0.1s	0.5s		P126
<u>P.244</u>	DC injection brake voltage before starting	0~30%	0.1%	4% (7.5kW or below) 2% (11kW~55kW) 1% (75kW or above)		P126
<u>P.245</u>	Cooling fan operation selection	0~3	0	0		P127
<u>P.246</u>	Modulation coefficient	0.90~1.20	0.01	1		P128
<u>P.247</u>	MC switchover interlock time	0.1~100s	0.1s	1s		P128

# Appendix 1 Parameter Table

Parameter Number	Name	Setting Range	Minimum Unit	Default value	User Setting Value	Reference Page
<u>P.248</u>	Start waiting time	0.1~100s	0.1s	0.5s		P128
<u>P.249</u>	Automatic switchover frequency from inverter to commercial power supply frequency	0~60Hz, 99999	0.01Hz	99999		P128
<u>P.250</u>	Automatic switchover frequency range from commercial power supply to inverter	0~10Hz, 99999	0.01Hz	99999		P128
<u>P.251</u>	Injection molding machine mode selection	0~4	1	0		P131
<u>P.252</u>	Flow channel weighted coefficient	0~100%	0.1%	100%		P131
<u>P.253</u>	Pressure channel weighted coefficient	0~100%	0.1%	100%		P131
<u>P.254</u>	Corner frequency	0~100Hz	0.01Hz	0 Hz		P131
<u>P.285</u>	Low frequency vibration inhibition factor	0~3	1	1		P132
<u>P.286</u>	High frequency vibration inhibition factor	0~15	1	0		P132
<u>P.287</u>	Short circuit protection (SCP) function selection	0~1	1	1		P133
<u>P.288</u>	Alarm code display option	0~12	1	0		P133
<u>P.289</u>	Alarm code	---	---	0		P133
<u>P.290</u>	The latest alarm status selection	0~7	1	0		P133
<u>P.291</u>	The latest alarm message	---	---	0		P133
<u>P.292</u>	Accumulative motor operation time (minutes)	0~1439min	1min	0 min		P134
<u>P.293</u>	Accumulative motor operation time (days)	0~9999day	1day	0 day		P134
<u>P.294</u>	Decryption parameter	0~65535	1	0		P134
<u>P.295</u>	Password setup	2~65535	1	0		P134
<u>P.300</u>	Motor control mode selection	0~4	1	0		P135
<u>P.301</u>	Motor parameter auto-tuning function selection	0~3	1	0		P135
<u>P.302</u>	Motor rated power	0~160	0.01	0		P137
<u>P.303</u>	Motor poles	0~8	1	4		P137
<u>P.304</u>	Motor rated voltage	0~440V	1 V	220/440V		P137

# Appendix 1 Parameter Table

Parameter Number	Name	Setting Range	Minimum Unit	Default value	User Setting Value	Reference Page
<u>P.305</u>	Motor rated frequency	0~400Hz	0.01Hz	50Hz/60Hz (Note 2)		P137
<u>P.306</u>	Motor rated current	0~500A	0.01 A	Horsepower-based		P137
<u>P.307</u>	Motor rated rotation speed	0~65535 r/min	1 r/min	1410/1710 r/min (Note 2)		P137
<u>P.308</u>	Motor excitation current	0~500A	0.01 A	Horsepower-based		P137
<u>P.309</u>	Stator resistance	0~65535mΩ	1	Horsepower-based		P137
<u>P.310</u>	Rotor resistance	0~65535mΩ	1	Horsepower-based		P137
<u>P.311</u>	Leakage inductance	0~6553.5mH	0.1	Horsepower-based		P137
<u>P.312</u>	Mutual inductance	0~6553.5mH	0.1	Horsepower-based		P137
<u>P.320</u>	Speed control proportion coefficient	0~2000%	1%	100%		P138
<u>P.321</u>	Speed control integral coefficient	0~20s	0.01s	0.3s		P138
<u>P.350</u>	Number of pulses per revolution of the encoder	0~20000	1	1024		P139
<u>P.351</u>	Encoder input mode setup	0~4	1	0		P139
<u>P.352</u>	PG signal abnormality (zero speed) detection time	0~100s	0.1s	1s		P139
<u>P.353</u>	Motor over-speed detection frequency	0~30Hz	0.01Hz	4Hz		P139
<u>P.354</u>	PG over-speed detection time	0~100s	0.1s	1s		P139
<u>P.994</u>	Parameter copy readout	Refer to Chapter 5	---	---	---	P140
<u>P.995</u>	Parameter copy write-in	Refer to Chapter 5	---	---	---	P140
<u>P.996</u>	Alarm history clear	Refer to Chapter 5	---	---	---	P141
<u>P.997</u>	Inverter reset	Refer to Chapter 5	---	---	---	P141
<u>P.998</u>	Restoring all parameters to default values	Refer to Chapter 5	---	---	---	P141
<u>P.999</u>	Restoring some parameters to default values	Refer to Chapter 5	---	---	---	P141

# Appendix 1 Parameter Table

Note: 1. The torque boost, motor rated current and stator resistance values are shown in the table as follows

Inverter type	P.0	P.9
SF-020-5.5 K	3	24
SF-020-7.5 K/5.5K-G	3	33/24
SF-020-11 K/7.5K-G	2/3	49/33
SF-020-15 K/11K-G	2	65/49
SF-020-18.5 K/15K-G	2	75/65
SF-040-22K/18.5K-G	2	90/75
SF-020-30 K/22K-G	2	120/90
SF-020-37 K/30K-G	2	145/120
SF-020-45 /37K-G	2	170/145
SF-020-55 K/45K-G	2	212/170
SF-040-5.5 K	3	13
SF-040-7.5 K/5.5K-G	3	18/13
SF-040-11 K/7.5K-G	2/3	24/18
SF-040-15 K/11K-G	2	32/24
SF-040-18.5 /15K-G	2	38/32
SF-040-22K/18.5K-G	2	45/38
SF-040-30 K/22K-G	2	60/45
SF-040-37 K/30K-G	2	73/60
SF-040-45 K/37K-G	2	91/73
SF-040-55 K/45K-G	2	110/91
SF-040-75 K/55K-G	1/2	150/110
SF-040-90 K/75K-G	1	180/150
SF-040-110 K/90K-G	1	220/180
SF-040-132 K/110K-G	1	260/220
SF-040-160 K/132K-G	1	310/260

- The default value is determined by the set value of P.189. When P.189 = 0, the default value is 60Hz, which is applicable to 60Hz systems. When P.189 = 1, the default value is 50Hz, which is applicable to 50Hz systems.
- According to the value of P.186, please refer to the parameter instruction for P.22.
- Parameters P.190 and P.191 are the calibrating values. Therefore the default value for each machine may differ slightly.

## Appendix 2 Alarm Code List

Alarm code list

Code	Screen Display	Cause	Troubleshooting
<b>ERROR</b>	Error	<ol style="list-style-type: none"> <li>Under-voltage for power supply</li> <li>The reset function "RES" is on</li> <li>Bad connection between the operation panel and main machine</li> <li>Internal circuit malfunction</li> <li>Wrong CPU operation</li> </ol>	<ol style="list-style-type: none"> <li>Provide a normal power supply</li> <li>Shut off "RES"</li> <li>Ensure firm connection between the operation panel and the main machine</li> <li>Replace the inverter.</li> <li>Restart the inverter</li> </ol>
<b>OC0</b> Over-current when stop	OC0	The output current is two times larger than the rated current of the inverter.	Please restart the inverter. If the alarm repeated, please send the inverter back to the factory.
<b>OC1</b> Over-current during acceleration	OC1		<ol style="list-style-type: none"> <li>In case the time for acceleration or deceleration is too short, extend it as necessary.</li> <li>Avoid abrupt increase of load.</li> <li>Check Terminals <b>U/T1, V/T2 and W/T3</b> for short circuit.</li> </ol>
<b>OC2</b> Over-current at constant speed	OC2		
<b>OC3</b> Over-current during deceleration	OC3		
<b>OV0</b> Over-voltage when stop	OV0	Over-voltage between Terminals P and N.	Check whether the power supply is normal or abnormal.
<b>OV1</b> Over-voltage during acceleration	OV1		<ol style="list-style-type: none"> <li>In case the time for acceleration or deceleration is too short, extend it as necessary.</li> <li>Check the brake resistor between Terminals <b>+P</b> and PR for loose connection.</li> <li>Check whether the values of <u>P.30</u> and <u>P.70</u> are correct or not.</li> </ol>
<b>OV2</b> Over-voltage at constant speed	OV2		
<b>OV3</b> Over-voltage during deceleration	OV3		





## Appendix 2 Alarm Code List

Alarm code list

Code	Screen Display	Cause	Troubleshooting
<b>THT</b> Overheated IGBT module	<b>THT</b>	IGBT module thermal accumulation relay operation	Avoid prolonged inverter operation when overloaded.
<b>THN</b> Overheated motor	<b>THN</b>	Electronic thermal relay operation	<ol style="list-style-type: none"> <li>1. Check whether the set value of <u>P.9</u> is correct or not (according to the externally connected motor).</li> <li>2. Reduce load.</li> </ol>
<b>FAN</b> Cooling fan alarm	<b>FAN</b>	Cooling fan failure	<ol style="list-style-type: none"> <li>1. The cooling fan is damaged. Please replace it with a new fan.</li> <li>2. Please clean the fan if it is blocked by foreign substances.</li> <li>3. Check if fans wiring is broken/loose, or replace it with a new fan.</li> </ol>
<b>OHT</b> External thermal relay operation	<b>OHT</b>	External thermal relay operation	<ol style="list-style-type: none"> <li>1. Check whether the capacity of the external thermal relay and of the motor coordinates well.</li> <li>2. Reduce the load.</li> </ol>
<b>OPT</b> Abnormal peripheral devices	<b>OPT</b>	<ol style="list-style-type: none"> <li>1. Abnormal communication; Exceeding the number of communication retries</li> <li>2. Interrupted communication; Exceeding the permitted communication time interval</li> </ol>	Correctly set the communication parameters.
<b>EEP</b> Abnormal memory	<b>EEP</b>	ROM malfunction	Send the inverter back to the factory if this type of alarm happens frequently.
<b>PID</b> Abnormal PID	<b>PID</b>	<ol style="list-style-type: none"> <li>1. Insufficient inverter and motor capacity</li> <li>2. PID target value or feedback value set unreasonably</li> <li>3. Peripheral devices malfunction</li> </ol>	<ol style="list-style-type: none"> <li>1. Enlarge the inverter and motor capacity.</li> <li>2. Check the feedback gain setup. Reset the target value according to the feedback.</li> <li>3. Check the system's peripheral feedback devices (e.g., sensors, potentiometer) and whether the wiring is correct.</li> </ol>

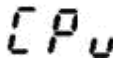
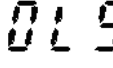
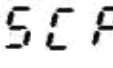
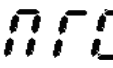
## Appendix 2 Alarm Code List

Alarm code list

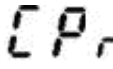
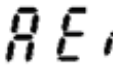
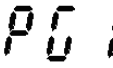
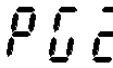
Code	Screen Display	Causes	Troubleshooting
<b>CPU</b> Abnormal CPU		Serious peripheral electromagnetic interference	Reduce peripheral interference.
<b>OLS</b> Stall prevention and protection		Over-loaded motor	<ol style="list-style-type: none"> <li>1. Reduce motor load.</li> <li>2. Increase P.22 value.</li> </ol>
<b>SCP</b> Short circuit over-current		Output-end short circuit	Check whether the inverter output has short circuit (e.g., the motor wiring).
<b>NTC</b> Overheated module		The temperature of the IGBT module is too high.	<ol style="list-style-type: none"> <li>1. Reduce the environment temperature and improve the air condition.</li> <li>2. Check whether the fan of the inverter is damaged.</li> </ol>
<b>OL2</b> Abnormal over-torque		<ol style="list-style-type: none"> <li>1. Over-loaded motor</li> <li>2. <u>P.155, P.156</u> set unreasonably.</li> </ol>	<ol style="list-style-type: none"> <li>1. Reduce motor load.</li> <li>2. Adjust the set value of <u>P.155, P.156</u> properly.</li> </ol>
<b>bE</b> Abnormal brake-resistor (Abnormal relay)		Abnormal brake-resistor (Abnormal relay)	Return it to the factory for repair.
<b>IPF</b> Abnormal power supply input		Abnormal power supply input	Check whether power supply input is normal.
<b>CPr</b> Abnormal CPU		Abnormal PU procedures	<ol style="list-style-type: none"> <li>1. Check the wiring.</li> <li>2. Check the parameter setup.</li> <li>3. Reduce peripheral interference.</li> </ol>
<b>AEr</b> Abnormal 4-5 terminal		Abnormal disconnection of 4-5 terminal's analog output	Please refer to the description for <u>P.184</u> .
<b>PG1</b> Abnormal encoder model		Abnormal encoder model	Check the set value of <u>P.351</u> .
<b>PG2</b> Abnormal PG card feedback signals		Abnormal PG card feedback signals	Please refer to the feedback control parameter description for <u>P.350~P.354</u> .

## Appendix 2 Alarm Code List

Code	Screen Display	Causes	Troubleshooting
<b>PG3</b> Too large speed deviation under closed-loop control	<b>PG3</b>	Too large speed deviation under closed-loop control	Please refer to the feedback control parameter description for <u>P.350~P.354</u> .

Note: 1. For the types below 40HP, "BE" alarm is a brake-resistor alarm, and relay alarm for types above 40HP.  
2. When the above alarms occur, the inverter will stop. Please handle these alarms according to the methods mentioned above.  
3. Refer to P.288~P.291 for abnormal alarm codes.

## Appendix 3 Troubles and Solutions

Troubles	Check points
Motionless motor	<p>Main circuit</p> <p>Check whether the power supply voltage between Terminals <b>R/L1, S/L2 and T/L3</b> is normal.</p> <p>Check whether the Power light is on.</p> <p>Check whether the wiring between the inverter and the motor is correct.</p>
	<p>Load</p> <p>Check whether the load is too heavy.</p> <p>Check whether the motor rotor is locked.</p>
	<p>Parameters Setting</p> <p>Check whether the starting frequency (<u>P.13</u>) is set too big.</p> <p>Check whether the operation mode (<u>P.79</u>) is correct.</p> <p>Check whether the maximum frequency (<u>P.1</u>) is zero.</p> <p>Check whether the reverse rotation prevention is restricted.</p> <p>Check whether the bias and gain (<u>P.192~P.199</u>) setting is correct.</p> <p>Check that the frequency jump (<u>P.91~P.96</u>) setting is correct.</p>
	<p>Control circuit</p> <p>Check whether the output stop signal "MRS" is on. (Related parameter <u>P.80~P.84, P.86, P.126~P.128</u>).</p> <p>Check whether the "RES" function is ON. (Related parameter <u>P.80~P.84, P.86, P.126~P.128</u>).</p> <p>Check whether the external thermal relay is operating or not.</p> <p>Check whether the reset has been performed or not after the set-off of the alarm (the ALARM light in on).</p> <p>Check whether the voltage/current signals are correctly wired.</p> <p>Check whether the functions of STF and STR are correct (related parameter <u>P.80~P.84, P.86, P.126~P.128</u>).</p> <p>Check whether the wiring for the control circuit is disconnected or has a poor contact.</p>
Reversed motor rotation	<p>Check whether the phase sequence of output terminals <b>U/T1, V/T2 and W/T3</b> is correct.</p> <p>Check whether the start signal (STF and STR) are connected correctly.</p>
Failure to increase the rotation speed of the motor	<p>Check whether the load is too heavy.</p> <p>Check whether the stall prevention level (<u>P.22</u>) is correct.</p> <p>Check whether the torque boost (<u>P.0</u>) is set too high.</p> <p>Check whether the maximum frequency (<u>P.1</u>) is effective.</p>
Unsmoothed acceleration / deceleration	<p>Check whether the acceleration / deceleration time (<u>P.7, P.8</u>) is correct.</p> <p>Check whether the acceleration / deceleration curve selection (<u>P.29</u>) is correct.</p> <p>Check whether the voltage / current input signals are affected by noises.</p>
Overlarge motor current	<p>Check whether the load is too heavy.</p> <p>Check whether the capacity of the inverter and of the motor are well matched.</p> <p>Check whether the torque boost (<u>P.0</u>) is set too high.</p>
Speed variation during the operation	<p>Check whether the voltage / current input signals are affected by noises.</p> <p>Check whether the load varies.</p> <p>Check whether the wiring length of the main circuit is too long.</p>

## Appendix 4 Optional Equipment

1. Expansion board (Please set the parameters according to the connected expansion board and the corresponding functions.)
  - 1). PM01 Injection modeling machine specific expansion card

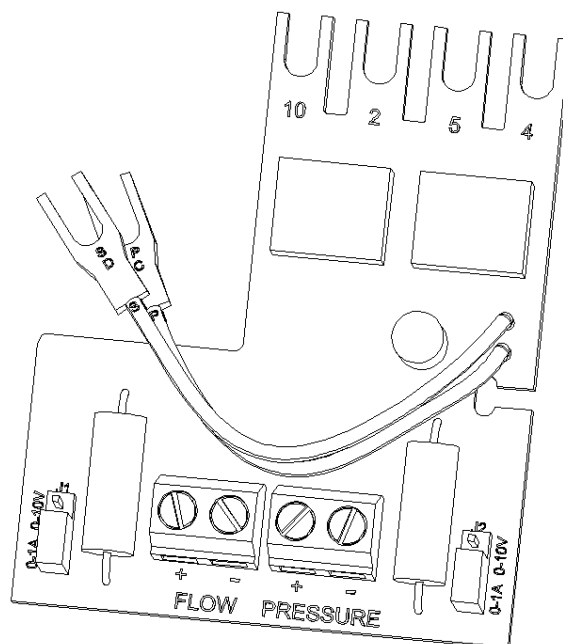

Terminal Type	Terminal Number	Terminal Function
Analog signal input	FLOW+	Flow signal +
	FLOW-	Flow signal -
	J1	Flow input signal selection. When the short-circuit board is inserted into the 0~10V side on the top, the flow signal will be the 0~10V voltage signal input terminal. When the short-circuit board is inserted into the 0~1A side on the bottom, the flow signal will be the 0~1A current signal input terminal.
	PRESSURE+	Pressure signal +
	PRESSURE-	Pressure signal -
	J2	Pressure input signal selection. When the short-circuit board is inserted into the 0~10V side on the top, the pressure signal will be the 0~10V voltage signal input terminal. When the short-circuit board is inserted into the 0~1A side on the bottom, the pressure signal will be the 0~1A current signal input terminal.

Note: For more details, please refer to the instruction on PM01, the injection modeling machine specific expansion card.

Description on the ordering code:

NO.	Model	Item Name	Ordering Code
1	PM01	PM01 Injection modeling machine specific expansion card	SNKSFGPM01

## 2). Fan and water pump multi-channel control card

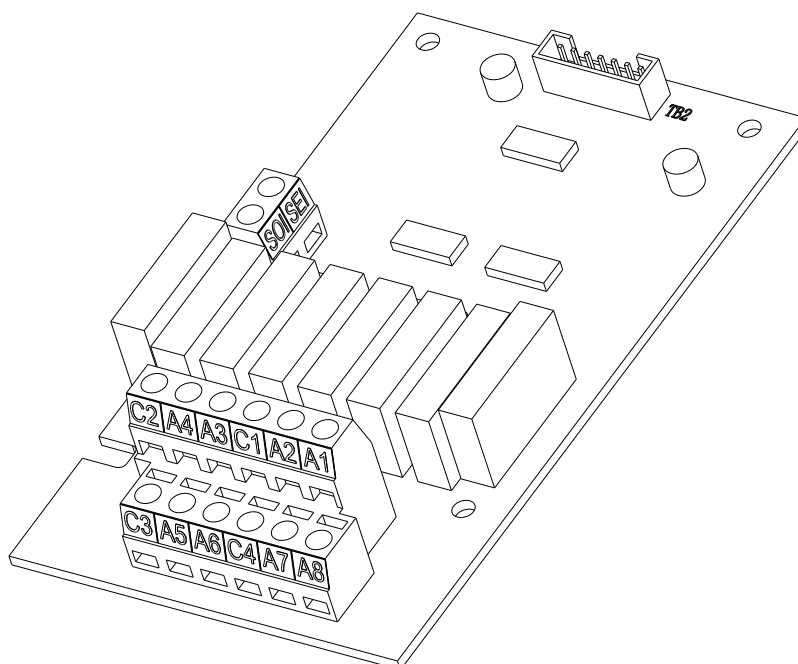

Terminal Number	Terminal Name	Content
A1~A8	Relay contact output terminal	It is used to drive the external electromagnetic switch or the relay. A1~A8 corresponds to RY1~RY8.
C1~C4	Relay contact output common terminal	For the relay contact output common terminal, C1 is the shared terminal for A1 and A2. C2 is the shared terminal for A3 and A4. C3 is the shared terminal for A5 and A6. C4 is the shared terminal for A7 and A8.
SOI and SEI	Expansion terminal	This terminal is connected to SU and SE of the inverter (set P.40=12) to control the signal of RY8.

Note: 1. For more details, please refer to the instruction on the fan and water pump multi-channel control card.

2. When connecting to two or more motors, make the corresponded common terminal short circuit.

Description on the ordering code:

NO.	Model	Item Name	Ordering Code
1	WS01	Fan and water pump multi-channel control card	SNKSFWS01

### 3). PG01 expansion card

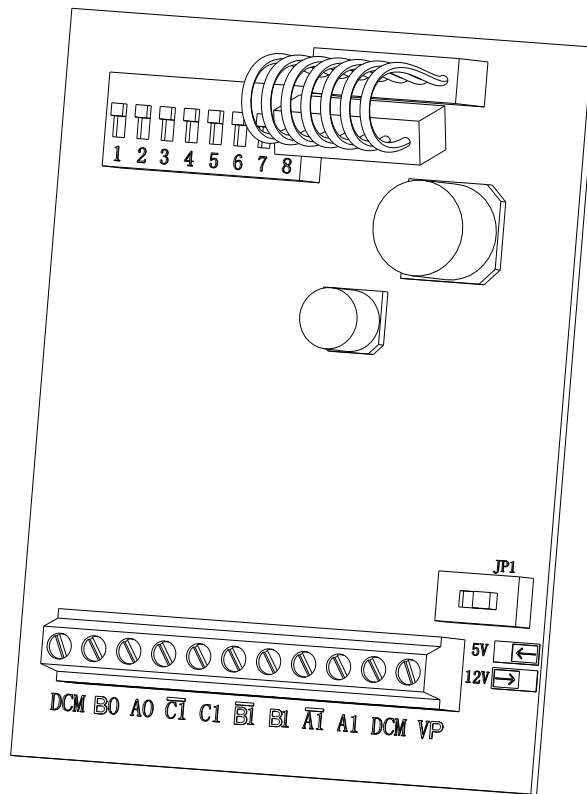

Terminal Name	Description
VP	Encoder power source (Use JP1 to switch to 12V or 5V) Output voltage : +12V±5% 200mA +5V±2% 200mA
DCM	The common ground for the power source and the signal (Be aware that DCM on the left is the ground for the frequency divider's signal output terminal).
A1, $\overline{A1}$ B1, $\overline{B1}$ C1, $\overline{C1}$	Encoder signal input terminal, the maximal input signal is 80HZ
A0,B0	Frequency divider's signal output terminal, the DC maximum is 24V、50mA

Description on the ordering code:

NO.	Model	Item Name	Ordering Code
1	PG01	PG01 expansion card	SNKPG01

# Appendix 4 Optional Equipment

## 2. Operation panel, operation panels' fixed base and the data transmission line

### 1). DU01S: DU01 operation panel set (operation panel (DU01) and the fixed base (GMB01))

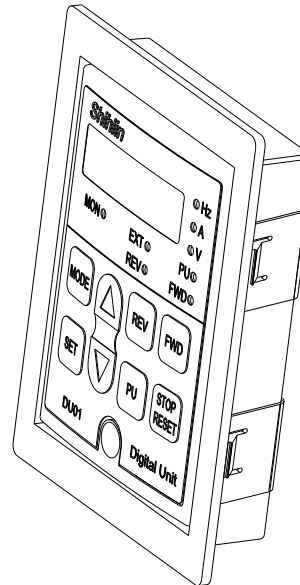
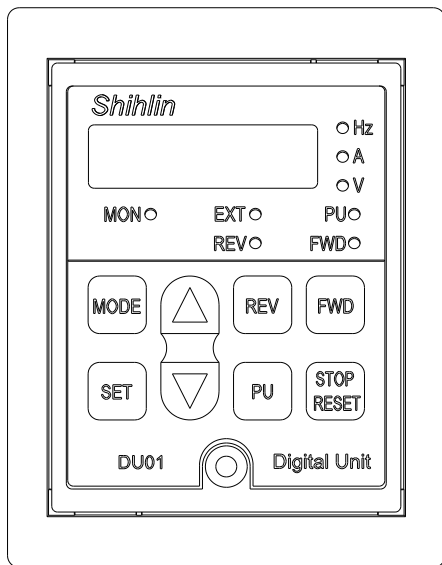

Description on the ordering code:

NO.	Model	Item Name	Ordering Code
1	DU01S	DU01 operation panel set	SNKDU01S

### 2). PU01 operation panel:

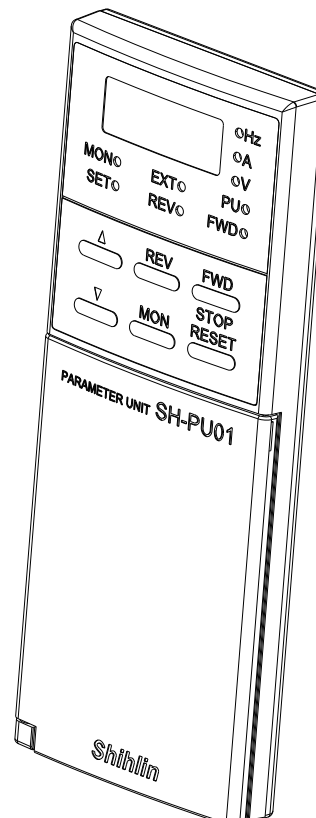
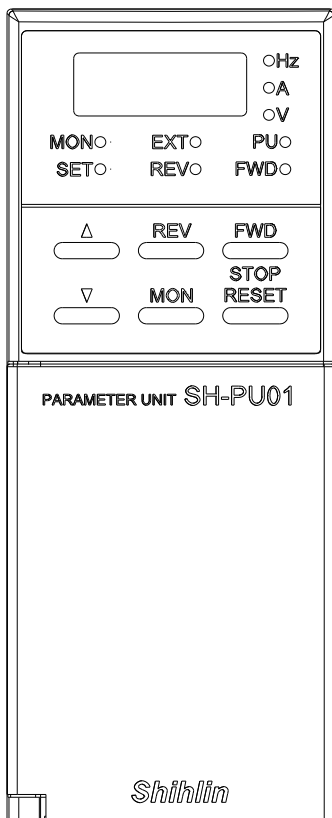

## Appendix 4 Optional Equipment

*Optional equipment*

Description on the ordering code:

NO.	Model	Item Name	Ordering Code
1	SH-PU01	PU01 operation panel set	SNKSHPU01

3). CBL: Data transmission line (coordinated with the operation panel)

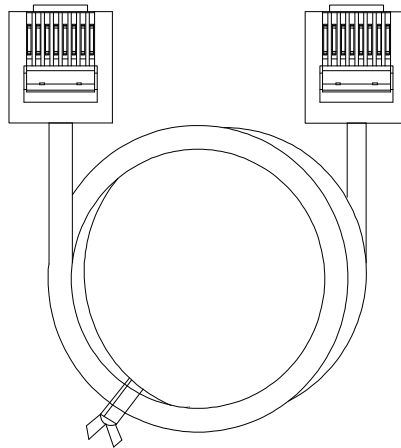

Description on the ordering code:

NO.	Model	Item name	Ordering code
1	CBL1R5GT	Data transmission line (Length: 1.5M)	SNKCBL1R5GT
2	CBL03GT	Data transmission line (Length: 3M)	SNKCBL03GT
3	CBL05GT	Data transmission line (Length: 5M)	SNKCBL05GT

**This inverter qualifies the CE label. Specifications:**

**Low Voltage Directive 2006/95/EC & Electromagnetic Compatibility Directive 2004/108/EC**

1. Electromagnetic compatibility command (EMC):

(1). EMC compatibility description:

For system integration, inverter is not a functionally independent device unit. It is usually a unit in the control box. It is combined with other devices to control a machine or equipment. Therefore, our company does not consider that all the EMC commands should be directly applied on the inverter. As a result, the CE label of this inverter is not extensible.

(2). Compatibility:

The inverter does not need to cover all the EMC commands. Yet, for certain machine equipment that needs to use EMC commands and the inverter, the machine has to be equipped with CE label. In addition, the company can provide the electromagnetic inspection data and operation manual that covers the required electromagnetic compatibility specifications for a quick and easy installation of the machine equipment of this inverter.

(3). Installation outline:

Please follow the following notes for installing the inverter:

Use a noise filter qualifying the EU standard to coordinate with the inverter.

The wire between the motor and the inverter has to be stored in shielded cable or metal tube. In addition, ground the motor terminal and the inverter terminal together. Please shorten the wire as much as possible.

Please put this inverter in a metal cabinet that is already grounded. It can prevent radiation interference.

The line-to-line noise filter at the power source terminal and the online magnetic iron core at the control row are used for suppressing noises. All the signals and the EU-qualified filter specifications are described in details in the operation manual. Please contact your agent.

2. Low-voltage command (LVD):

(1). Low-voltage command compatibility description:

This inverter is compatible with low-voltage commands.

(2). Compatibility:

Our company qualifies the low-voltage command specification.

(3). Description;

Do not rely on leakage protection only for preventing electric shocks. Grounding is required for the protection.

Ground each inverter individually (do not connect more than two (including two) ground cables).

Please use non-fuse switch and electromagnetic contactor that qualify EN or IEC specifications.

Please use the inverter under an environment of over-voltage level-2 condition with contamination level 2 or better.

For the style and dimensions of the input- and output-end of the inverter cable, please refer to the specifications listed in the operation manual.

## CE Certification Statement



### VERIFICATION OF CONFORMITY

CERTIFICATE NO: VC/2010/10/0501/CE

Applicant	Name	Shihlin Electric& Engineering Corporation
	Address	No.234, ChungLun, HsinFun, HsinChu, Taiwan, R.O.C.
Manufacturer	Name	Shihlin Electric& Engineering Corporation
	Address	No.234, ChungLun, HsinFun, HsinChu, Taiwan, R.O.C.
	Name	: Suzhou Shihlin Electric& Engineering Corporation
	Address	: 22 Huoju Road, Suzhou New District, Jiangsu
Description	Trader Mark	
	Product Name	Inverter
	Model	: SF-020-5.5K,SF-020-7.5K/5.5K-G,SF-020-11K/7.5K-G SF-020-15K/11K-G,SF-020-18.5K/15K-G,SF-040-5.5K,SF-040-7.5K/5.5K-G,SF-040-11K/7.5K-G,SF-040-15K/11K-G SF-040-18.5K/15K-G,SF-040-22K/18.5K-G
Applicable Directives	Low Voltage Directive 2006/95/EC & Electromagnetic Compatibility Directive 2004/108/EC	
Applicable Standards	: Safety:EN61800-5-1:2007, EMC:EN61800-3:2004, EN55011:2007,EN61000-2-2:2002, IEC61000-4-2:2001,IEC61000-4-3:2006, IEC61000-4-4:2006, IEC61000-4-5:2005, IEC61000-4-6:2006, IEC61000-4-8:2001	

VIACERT as the Third Party Authority ,upon the relevant request of Shihlin Electric & Engineering Corporation, Certifies that :the test results of the above mentioned products comply with the requirement of the EN Standard ,according to EU Low Voltage Directive 2006/ 95/EC and Electromagnetic Compatibility Directive 2004/108/EC The manufacturer is obliged to issue a Declaration of Conformity according to the basic requirement of relative Directives and places the CE marking with his own responsibility as follows:



All modifications to the Technical File should be first submitted to the Third Party Inspection Authority to ensure further validity of this attestation.

Third Party Authority stamp



Date and Place of Issue
Shanghai, 19/05/2010
FOR VIACERT
KELVIN GAO GENERAL MANAGER

VIACERT TESTING & CERTIFICATION  
14E, TIANSHAN ROAD 600, SHANGHAI, P.R.CHINA 200051

TEL:+86-21 51088618, FAX:+86-21 51801927  
EMAIL:info@via-cert.com



## VERIFICATION OF CONFORMITY

CERTIFICATE NO: VC/2010/10/0501/CE

Applicant	Name	Shihlin Electric& Engineering Corporation
	Address	No.234, ChungLun, HsinFun, HsinChu, Taiwan, R.O.C.
Manufacturer	Name	Shihlin Electric& Engineering Corporation
	Address	No.234, ChungLun, HsinFun, HsinChu, Taiwan, R.O.C.
	Name	: Suzhou Shihlin Electric& Engineering Corporation
	Address	: 22 Huoju Road, Suzhou New District, Jiangsu
Description	Trader Mark	
	Product Name	Inverter
	Model	: SF-020-22K/18.5K-G,SF-020-30K/22K-G,SF-020-37K/30K-G, SF-020-45K/37K-G,SF-020-55K/45K-G,SF-040-30K/22K-G, SF-040-37K/30K-G,SF-040-45K/37K-G,SF-040-55K/45K-G, SF-040-75K/55K-G,SF-040-90K/75K-G,SF-040-110K/90K-G, SF-040-132K/110K-G,SF-040-160K/132K-G,
Applicable Directives	Low Voltage Directive 2006/95/EC & Electromagnetic Compatibility Directive 2004/108/EC	
Applicable Standards	: Safety:EN61800-5-1:2007, EMC:EN61800-3:2004, EN55011:2007,EN61000-2-2:2002, IEC61000-4-2:2001,IEC61000-4-3:2006, IEC61000-4-4:2006, IEC61000-4-5:2005, IEC61000-4-6:2006, IEC61000-4-8:2001	

VIACERT as the Third Party Authority ,upon the relevant request of Shihlin Electric & Engineering Corporation, Certifies that :the test results of the above mentioned products comply with the requirement of the EN Standard ,according to EU Low Voltage Directive 2006/ 95/EC and Electromagnetic Compatibility Directive 2004/108/EC The manufacturer is obliged to issue a Declaration of Conformity according to the basic requirement of relative Directives and places the CE marking with his own responsibility as follows:



All modifications to the Technical File should be first submitted to the Third Party Inspection Authority to ensure further validity of this attestation.

Third Party Authority Stamp



Date and Place of Issue
Shanghai, 19/05/2010
FOR VIACERT
KELVIN GAO
GENERAL MANAGER

VIACERT TESTING& CERTIFICATION  
14E, TIANSHAN ROAD 600, SHANGHAI, P.R.CHINA 200051

TEL:+86-21 51088618, FAX:+86-21 51801927  
EMAIL:info@via-cert.com

## Australia C-Tick Certification Statement

### Supplier's declaration of conformity

For compliance levels 1, 2 and 3 in Australia



As required by the following Notices:

- *Radiocommunications Devices (Compliance Labelling) Notice 2003* made under section 182 of the Australian *Radiocommunications Act 1992*;
- *Radiocommunications Labelling (Electromagnetic Compatibility) Notice 2008* made under section 182 of the Australian *Radiocommunications Act 1992*;
- *Radiocommunications (Compliance Labelling – Electromagnetic Radiation) Notice 2003* made under section 182 of the Australian *Radiocommunications Act 1992*; and
- *Telecommunications Labelling (Customer Equipment and Customer Cabling) Notice 2001* made under section 407 of the Australian *Telecommunications Act 1997*

#### Instructions for completion

- **Do not return this form to the ACMA.** This completed form must be retained by the supplier as part of the documentation required for the compliance records and must be made available for inspection by the ACMA when requested.

#### Supplier's details (manufacturer, importer or authorised agent)

Company Name (OR INDIVIDUAL)

Shihlin Electric (Australia) Pty Ltd
TRADING AS Shihlin Electric (Australia) Pty Ltd

ACMA supplier code number

N29467
--------

OR

Street Address

Suite 2, Building 6, Omnico Business Park, 270, Ferntree
Gully Road, Notting Hill, VIC 3168, Australia
POSTCODE 3162

ACN, ABN, or ARBN

ABN NO:58 137 152 455
-----------------------

#### Product details

Product description – brand name, type, model, lot, batch or serial number (if available)

Brand Name : <b>Shihlin Electric &amp; Engineering Corporation</b>
Model Number : <b>SF-(X)-(Y)</b> <b>SF-(X)-(Y)-G</b> X=Input Voltage= 020 : 220V 3-Phase 040 : 440V 3-Phase Y=Suitable Motor= 0.75K : 0.75KW 1.5K : 1.5KW .....
Description : <b>AC MOTOR Drive</b>

#### Compliance

The above mentioned product complies with the requirements of the relevant ACMA Standards made under the *Radiocommunications Act 1992* and the *Telecommunications Act 1997*. These Standards are referenced in notices made under *section 182 of the Radiocommunications Act* and *407 of the Telecommunications Act*.

Evidence of compliance is demonstrated by test reports to the following applicable standards.

#### Applicable standards

Standard title, number and, if applicable, number of the test report

<b>EN 61800-3:2004 Conductor Emissions</b>
<b>EN 61800-3:2004 Radiated Emissions</b>

#### Declaration

I hereby declare that the contents of this form are true and correct, that the product mentioned above complies with the relevant above mentioned standards and all products supplied under this declaration will be identical to the product identified above.

**Note:** Under section 137.1 of the *Criminal Code Act 1995*, it is an offence to knowingly provide false or misleading information to a Commonwealth entity.  
Penalty: 12 months imprisonment

SIGNATURE OF SUPPLIER OR AGENT <i>Jung-Cheng Peng</i>
Jung-Cheng Peng

Project Manager
15 Jun. 11

# Revision Record

Published Date	Edition of the Manual	Revision Content
2011.11	V1.00	First Edition
2012.05	V1.01	<p><b>Addition</b></p> <ol style="list-style-type: none"> <li>1. Page90 Adding picture explanation of restart function</li> <li>2. Page112 Adding the output power to Multi-function display</li> <li>3. Page122 Adding note of reference parameter for external analog setting</li> </ol> <p><b>modification</b></p> <ol style="list-style-type: none"> <li>1. Page4 Amending SF-020-55K/K-G applicable motor capacity to 75HP</li> <li>2. Page9-11 Amending some frame model</li> <li>3. Page19 Amending the picture of System Wire Arrangement</li> <li>4. Page20 Amending the picture of Terminal Wire Arrangement</li> <li>5. Page31-34 Amending parts of inverter type</li> <li>6. Page33 Amending frame to 'C、E、F'</li> <li>7. Page37 Amending the flow chart for switching the working mode using DU01 operation panel</li> <li>8. Page38 Amending Operation flow charts for monitoring mode and frequency setting mode with DU01</li> <li>9. Page39 Amending Operation flow charts for parameter setting mode with DU01</li> <li>10. Page 62 When p.32=3, amending the remarks to 'reserved'.</li> <li>11. Page88 Amending factory setting of P.191 to 600</li> <li>12. Page126 Amending the main frequency reference source</li> <li>13. Page143 Amending the picture of Inverter Insulation Resistance Measurement</li> <li>14. Page166 Amending terminal description of PG01 expansion card</li> </ol>
2012.10	V1.02 (Applicable for V0.30 or above firmware)	<ol style="list-style-type: none"> <li>1. Unifying names of some parameters</li> <li>2. Amending some mistakes of the instruction manual</li> </ol>

Version: V1.02

Published Date: October, 2012