

otomasyon AVM



## Shihlin Electric General Inverters

### SC3 Series

### User Manual

SC3-021-0.2K ~ 2.2K

SC3-023-0.2K ~ 3.7K

SC3-043-0.4K ~ 5.5K

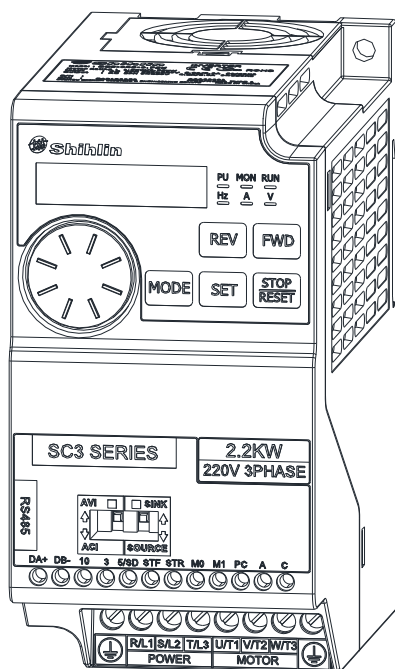

|                            |   |
|----------------------------|---|
| MANUAL GUIDE               | 1 |
| DELIVERY AND INSPECTION    | 2 |
| INVERTER INTRODUCTION      | 3 |
| PRIMARY OPERATION          | 4 |
| PARAMETER DESCRIPTION      | 5 |
| INSPECTION AND MAINTENANCE | 6 |
| APPENDIX                   | 7 |



# 1. MANUAL GUIDE

## 1.1 Safety instructions

Thank you for choosing Shihlin inverters of SC3 series. This instruction introduces how to correctly use this inverter. Before using this inverter, always carefully read this User Manual and moreover, please understand the safety instructions.

### Safety Instructions

- ✓ Installation, operation, maintenance and inspection must be performed by qualified personnel.
- ✓ In this instruction, the safety instruction levels are classified into "Warning" and "Caution".
  - ⚠ Warning: Incorrect handling may cause hazardous conditions, resulting in death or severe injury.
  - ⚠ Caution: Incorrect handling may cause hazardous conditions, resulting in medium or slight injury, or may cause only material damage.

### ⚠ Warning

- ✓ While the inverter power is ON, do not open the front cover or the wiring cover. Do not run the inverter with the front cover or the wiring cover removed. Otherwise you may access the exposed high voltage terminals or the charging part of the circuitry and get an electric shock.
- ✓ It is crucial to turn off the motor drive power before any wiring installation or inspection is made. Before the inverter CHARGE light is OFF, which indicates that there is still high voltage in it, please do not touch the internal circuit and components.
- ✓ The inverter must be connected to the ground properly.
- ✓ Do not operate or touch the radiator or handle the cables with wet hands. Otherwise you may get an electric shock.
- ✓ Do not change the cooling fan while power is ON. It is dangerous to change the cooling fan while power is ON.

### ⚠ Caution

- ✓ The voltage applied to each terminal must be the ones specified in the Instruction Manual. Otherwise burst, damage, etc. may occur.
- ✓ Do not conduct a pressure test on the components inside the inverter, for semiconductor of the inverter is easily to be broke down and damaged by high voltage.
- ✓ While power is ON or for some time after power-OFF, do not touch the inverter as it will be extremely hot. Touching these devices may cause a burn.
- ✓ The cables must be connected to the correct terminals. Otherwise burst, damage, etc. may occur.
- ✓ The polarity (+ and -) must be correct. Otherwise burst, damage, etc. may occur.
- ✓ Inverter must be installed on a nonflammable wall without holes (so that nobody touches the inverter heatsink on the rear side, etc.). Mounting it to or near flammable material may cause a fire.
- ✓ If the inverter has become faulty, the inverter power must be switched OFF. A continuous flow of large current may cause a fire.

## 1.2 Contents

|  |       |
|--|-------|
| User Manual .....  | - 1 - |
| 1. MANUAL GUIDE .....                                      | 1     |
| 1.1 Safety instructions.....                               | 1     |
| 1.2 Contents .....   | 2     |
| 1.3 Definitions of terminologies.....                      | 7     |
| 2. DELIVERY CHECK.....                                     | 8     |
| 2.1 Nameplate instruction.....                             | 8     |
| 2.2 Type instruction .....                                 | 8     |
| 2.3 Order code description .....                           | 8     |
| 3. INVERTER INTRODUCTION.....                              | 9     |
| 3.1 Electric specification .....                           | 9     |
| 3.1.1 440V series three-phase.....                         | 9     |
| 3.1.2 220Vseries three-phase.....                          | 10    |
| 3.1.3 220Vseries single-phase.....                         | 11    |
| 3.2 General specification .....                            | 12    |
| 3.3 Appearance and dimensions.....                         | 13    |
| 3.3.1 Frame A.....   | 13    |
| 3.3.2 Frame B.....   | 14    |
| 3.4 Name of each component.....                            | 15    |
| 3.4.1 Frame A/B .....                                      | 15    |
| 3.5 Installation and wiring .....                          | 16    |
| 3.5.1 Transportation .....                                 | 16    |
| 3.5.2 Storage .....  | 16    |
| 3.5.3 Installation notice .....                            | 16    |
| 3.5.4 EMC installation instructions .....                  | 18    |
| 3.6 Peripheral devices.....                                | 19    |
| 3.6.1 System Wire Arrangement .....                        | 19    |
| 3.6.2 No-fuse switch and magnetic contactor.....           | 20    |
| 3.6.3 Brake Resistor .....                                 | 21    |
| 3.7 Terminal wire arrangement.....                         | 22    |
| 3.7.1 Main circuit Terminals .....                         | 23    |
| 3.7.2 Main circuit wiring and terminal specification ..... | 24    |
| 3.7.3 Ground.....  | 25    |
| 3.7.4 RFI filter .....                                     | 25    |
| 3.7.5 Control circuit.....                                 | 26    |
| 3.8 Replacement procedure of fan.....                      | 31    |
| 3.8.1 Frame A/B .....                                      | 31    |
| 4. PRIMARY OPERATION.....                                  | 32    |
| 4.1 Component name of operation panel.....                 | 32    |

|  |    |
|--|----|
| 4.2 Operation modes of the inverter .....  | 33 |
| 4.2.1 The flow chart for switching the operation mode.....                           | 34 |
| 4.2.2 The flow chart for switching the working mode .....                            | 34 |
| 4.2.3 The operation flow charts for monitoring mode.....                             | 35 |
| 4.2.4 Operation flow charts for frequency setting mode .....                         | 35 |
| 4.2.5 Operation flow charts for parameter setting mode.....                          | 36 |
| 4.2.6 Operation flow charts of HELP model, using SC3-TYPE operation panel.....       | 36 |
| 4.3 Basic operation procedures for different modes.....                              | 37 |
| 4.3.1 Basic operation procedures for PU mode (00-16(P.79) = 0 or 1) .....            | 37 |
| 4.3.2 Basic operation procedures for external mode (00-16(P.79) = 0 or 2).....       | 37 |
| 4.3.3 Basic operation procedures for JOG mode (00-16(P.79) = 0 or 1).....            | 38 |
| 4.3.4 Basic operation procedures for communication mode (00-16(P.79) = 3).....       | 38 |
| 4.3.5 Basic operation procedures for combined mode 1 (00-16(P.79) = 4) .....         | 38 |
| 4.3.6 Basic operation procedures for combined mode 2 (00-16(P.79) = 5) .....         | 39 |
| 4.3.7 Basic operation procedures for combined mode 3 (00-16(P.79) = 6) .....         | 40 |
| 4.3.8 Basic operation procedures for combined mode 4 (00-16(P.79) = 7) .....         | 40 |
| 4.3.9 Basic operation procedures for combined mode 5 (00-16(P.79) = 8) .....         | 41 |
| 4.4 Operation.....   | 42 |
| 4.4.1 Pre-operation checks and preparation.....                                      | 42 |
| 4.4.2 Operation methods .....  | 42 |
| 4.4.3 Trial run .....  | 43 |
| 5. PARAMETER DESCRIPTION .....   | 44 |
| 5.1 System parameter group00 .....   | 44 |
| 5.1.1 Inverter information.....  | 47 |
| 5.1.2 Parameter restoration.....   | 48 |
| 5.1.3 Parameter protection .....   | 50 |
| 5.1.4 Monitoring function .....  | 52 |
| 5.1.5 Speed display .....  | 53 |
| 5.1.6 The Setting Frequency Selection of Rotary Knob on the Operating Keyboard ..... | 54 |
| 5.1.7 PWM Carrier frequency.....   | 54 |
| 5.1.8 Stop operation selection .....   | 55 |
| 5.1.9 Forward/reverse rotation prevention selection .....                            | 56 |
| 5.1.10 Operation mode selection.....   | 57 |
| 5.1.11 Control mode selection .....  | 57 |
| 5.1.12 50/60Hz switch selection .....  | 58 |
| 5.1.13 Parameter mode setting .....  | 59 |
| 5.2 Basic parameter group01 .....  | 60 |
| 5.2.1 Limiting the output frequency .....  | 62 |
| 5.2.2 Base frequency, base frequencyvoltage .....                                    | 63 |
| 5.2.3 Acceleration/deceleration time setting .....                                   | 64 |
| 5.2.4 Torque boost <b>V/F</b> .....  | 66 |

|  |     |
|--|-----|
| 5.2.5 Starting frequency .....   | 66  |
| 5.2.6 Load pattern selection <b>V/F</b> .....                                | 67  |
| 5.2.7 JOG operation .....  | 69  |
| 5.2.8 Output frequency filter time .....                                     | 69  |
| 5.2.9 Frequency jump.....  | 70  |
| 5.2.10 The second function .....   | 71  |
| 5.2.11 Middle frequency, output voltage of middle frequency <b>V/F</b> ..... | 72  |
| 5.2.12 S pattern time .....  | 73  |
| 5.3 Analog input and output parameter group 02 .....                         | 75  |
| 5.3.1 Proportion linkage gain .....  | 76  |
| 5.3.2 Auxiliary frequency .....  | 77  |
| 5.3.3 Selection and handling of input terminal 3-5.....                      | 78  |
| 5.3.4 Output current according to the benchmark .....                        | 83  |
| 5.4 Digital input/output parameter group03 .....                             | 84  |
| 5.4.1 Function selection of digital input .....                              | 87  |
| 5.4.2 Function selection of digital output.....                              | 90  |
| 5.4.3 Terminal logic selection .....   | 91  |
| 5.4.4 Output signal delay .....  | 92  |
| 5.4.5 Digital input terminal filter .....                                    | 92  |
| 5.4.6 Digital input terminal power enable .....                              | 93  |
| 5.4.7 Output frequency detection .....                                       | 93  |
| 5.4.8 Zero current detection .....   | 94  |
| 5.5 Multi-speed parameter group04.....                                       | 95  |
| 5.5.1 16 speeds.....   | 97  |
| 5.5.2 Programmed operation mode .....  | 99  |
| 5.6 Motor parameter group05 .....  | 103 |
| 5.6.1 Motor parameter auto-tuning function selection.....                    | 104 |
| 5.6.2 Motor parameter.....   | 106 |
| 5.7 Protection parameter group06 .....                                       | 107 |
| 5.7.1 Electronic thermal relay capacity .....                                | 109 |
| 5.7.2 Current stalling protection.....                                       | 109 |
| 5.7.3 Regenerative brake .....   | 110 |
| 5.7.4 Over torque detection.....   | 111 |
| 5.7.5 Cooling fan operation .....  | 112 |
| 5.7.6 Maintenance alarm function .....                                       | 112 |
| 5.7.7 Time record function.....  | 113 |
| 5.7.8 Alarm query function.....  | 113 |
| 5.8 Communication parameter group 07.....                                    | 115 |
| 5.8.1 Shihlin protocol and Modbus protocol.....                              | 116 |
| 5.8.2 Writing Selection of Communication EEPROM.....                         | 132 |
| 5.9 PID parameter group08.....   | 133 |

---

|   |     |
|---|-----|
| 5.9.1 PID function selection.....                                   | 134 |
| 5.9.2 PID parameter group.....                                      | 134 |
| 5.10 Application parameter group 10.....                            | 139 |
| 5.10.1 DC injection brake .....                                     | 142 |
| 5.10.2 Zero-speed/zero-servo control.....                           | 143 |
| 5.10.3 DC injection brake before start .....                        | 143 |
| 5.10.4 Restart mode selection .....                                 | 144 |
| 5.10.5 Remote setting function selection .....                      | 145 |
| 5.10.6 Retry selection.....   | 147 |
| 5.10.7 The dead time of positive and reverse rotation .....         | 148 |
| 5.10.8 Energy-saving control function <b>V/F</b> .....              | 148 |
| 5.10.9 Dwell function <b>V/F</b> .....                              | 149 |
| 5.10.10 Triangular wave function <b>V/F</b> .....                   | 151 |
| 5.10.11 Reciprocating engine function .....                         | 152 |
| 5.11 Speed and torque control parameter group 11 .....              | 154 |
| 5.11.1 Control parameter .....                                      | 154 |
| 5.11.2 Torque compensation filter .....                             | 154 |
| 5.12 Special adjustment parameter group 13.....                     | 155 |
| 5.12.1 Slip compensation <b>V/F</b> .....                           | 155 |
| 5.12.2 Vibration inhibition .....                                   | 155 |
| 5.13 User parameter Group 15.....                                   | 156 |
| 5.13.1 User registration parameters .....                           | 157 |
| 6. INSPECTION AND MAINTENANCE.....                                  | 158 |
| 6.1 Inspection item.....  | 158 |
| 6.1.1 Daily inspection item.....                                    | 158 |
| 6.1.2 Periodical inspection items .....                             | 158 |
| 6.1.3 Cleaning .....  | 159 |
| 6.1.4 Replacement of parts .....                                    | 159 |
| 6.2 Measurement of main circuit voltages, currents and powers ..... | 160 |
| 6.2.1 Selection of instruments for measurement .....                | 160 |
| 6.2.2 Measurement of voltages .....                                 | 160 |
| 6.2.3 Measurement of currents .....                                 | 160 |
| 6.2.4 Measurement of power .....                                    | 161 |
| 6.2.5 Measurement of insulation resistance .....                    | 161 |
| 6.2.6 Hi-pot test.....  | 161 |
| 7. APPENDIX .....   | 162 |
| 7.1 Appendix 1 Parameter table .....                                | 162 |
| 7.2 Appendix 2 Alarm code list .....                                | 180 |
| 7.3 Appendix 3 Troubles and solutions .....                         | 183 |
| 7.4 Appendix 4 : Optional accessories .....                         | 184 |
| 7.4.1 PU301Parameter Unit .....                                     | 184 |

Definitions of terminologies

---

|  |     |
|--|-----|
| 7.4.2 DU06 operation panel .....   | 186 |
| 7.4.3 DU08 operation panel .....   | 187 |
| 7.4.4 DU10operation panel .....  | 189 |
| 7.4.5 CBL: Data transmission line (coordinated with the operation panel) ..... | 190 |
| 7.5 Appendix 6 European Specification Compatibility Description.....           | 191 |
| 8. REVISION RECORD .....   | 194 |

## 1.3 Definitions of terminologies

### ✓ Output frequency, target frequency, steady output frequency

- The actual output current frequency of the inverter is called “output frequency.”
- The frequency set by user (via operation panel, multi-speed terminals, voltage signal, and current signal or communication settings) is called “target frequency.”
- When the motor starts running, the output frequency of the inverter will gradually accelerate to the target frequency before it finally runs steadily at the target frequency. This output frequency is called “stead output frequency.”

### ✓ Parameter settings

- Detail explanation on parameter settings are provided in Chapter 5. For users who are not familiar with these settings, arbitrary adjustment of the parameter may result in abnormal operations. All parameters can be reset to their default values by the parameter of 00-02. For setting procedures of this parameter, please refer to 00-02 in Section 5.1.2.

### ✓ The “operation mode” and “working mode” of the operation panel

- The operating mode determines the reference source for the target frequency and the signal source for starting. A total of nine operating modes are provided in each Shihlin inverter. Please refer to Section 4.3 for details.
- The operation panel is used mainly for monitoring the numeric values, setting parameters and target frequency. There are a total of five working modes on the Shihlin operation panel. Please refer to Section 4.2 for details.

### ✓ The difference between “terminal name” and “function name”:

- Printed letters can be found near the terminals of either the control board or the main board. They are used to distinguish each terminal and are called “terminal name.”
- For “multi-function control terminal” and “multi-function output terminal,” besides the terminal name, it is also necessary to define the “function name.” The function name indicates the actual functions of the terminal.
- When explaining the function for a terminal, the name used is its “function name”

### ✓ The difference between “on” and “turn on”:

- When explaining the function for the “multi-function control terminal”, two words “on” and “turn on” are often used:
- The word “on” is used to indicate that the external switch of the terminal is in close state, and thus it belongs to the description of the state.
- The word “turn on” is used to describe the action that the external switch of the terminal is shut from the open state to the close state, and thus belongs to the description of action. Similarly, the words “off” and “turn off” belong to the above-mentioned states and actions.

### ✓ P.xxx

- P.xxx , indicates parameter number, not paper number.

## 2. DELIVERY CHECK

Each SC3-TYPE inverter has been checked thoroughly before delivery, and is carefully packed to prevent any mechanical damage. Please check for the following when opening the package.

- Checking out whether the product was damaged during transportation.
- Whether the model of inverter coincide with what is shown on the package.

### 2.1 Nameplate instruction

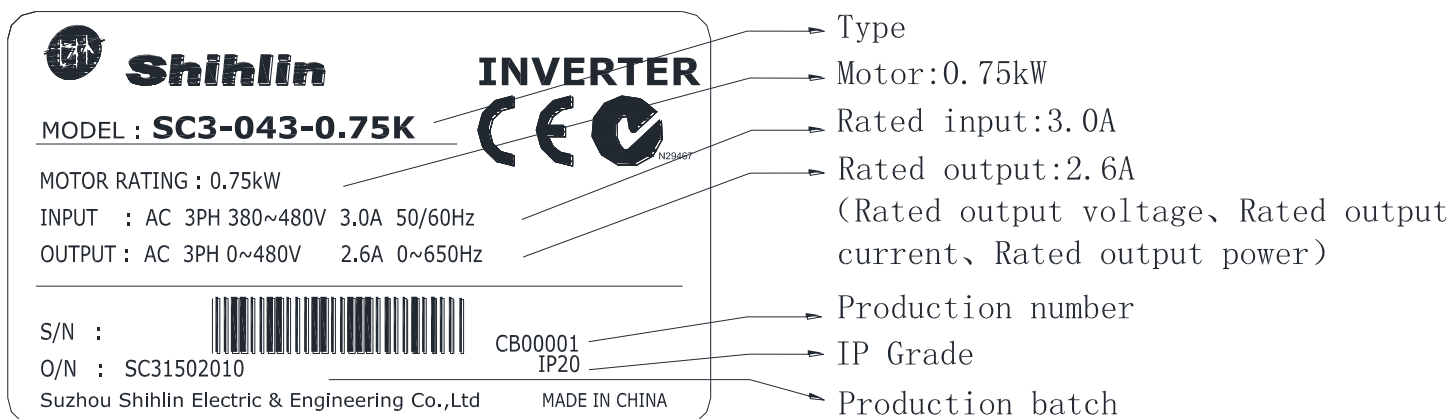

### 2.2 Type instruction

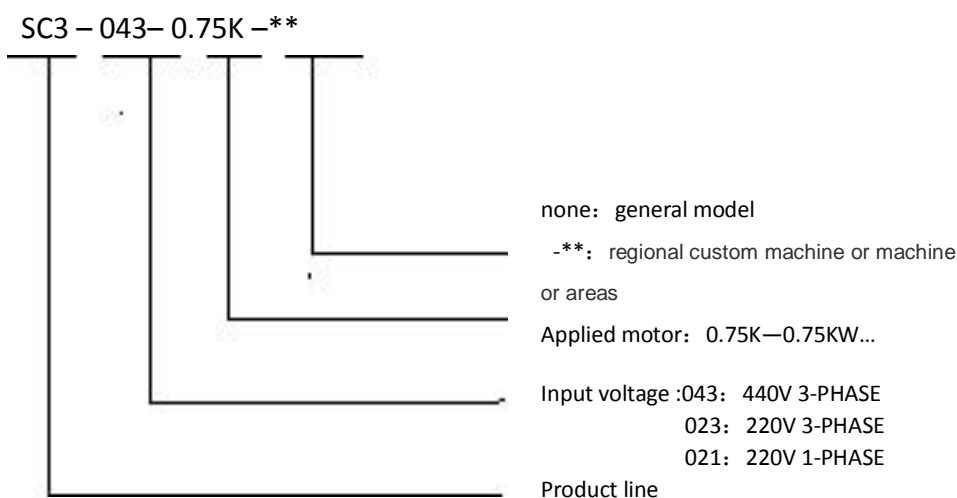

### 2.3 Order code description

Example:

| Specification | Description                    | Order         |
|---------------|--------------------------------|---------------|
| SC3-043-1.5K  | SC3 series 440V 1.5kW inverter | SNKSC30431R5K |
| SC3-043-3.7K  | SC3series 440V 3.7kW inverter  | SNKSC30433R7K |
| SC3-043-5.5K  | SC3series 440V 5.5kW inverter  | SNKSC30435R5K |

## 3. INVERTER INTRODUCTION

### 3.1 Electric specification

#### 3.1.1 440V series three-phase

| Frame                 |   | A   |                    |      | B    |      |      |
|-----------------------|---|---|--------------------|------|------|------|------|
| Model SC3-043-□□□K-□□ |   | 0.4   | 0.75               | 1.5  | 2.2  | 3.7  | 5.5  |
| Output                | Rated output capacity (kVA)             | 1   | 2                  | 3    | 4.6  | 6.9  | 9.2  |
|                       | Rated output current(A)                 | 1.5   | 2.6                | 4.2  | 6    | 9    | 12   |
|                       | Applicable motor capacity (HP)          | 0.5   | 1                  | 2    | 3    | 5    | 7.5  |
|                       | Applicable motor capacity (kW)          | 0.4   | 0.75               | 1.5  | 2.2  | 3.7  | 5.5  |
|                       | Overload current rating                 | 150% 60seconds 200% 1 second inverse time characteristics |                    |      |      |      |      |
|                       | Carrier frequency (kHz)                 | 1~15kHz   |                    |      |      |      |      |
|                       | Maximum output voltage                  | Three-phase 380-480V                                      |                    |      |      |      |      |
| Power supply          | Rated power voltage                     | Three-phase 380-480V 50Hz / 60Hz                          |                    |      |      |      |      |
|                       | Power voltage permissible fluctuation   | Three-phase 323-528V 50Hz / 60Hz                          |                    |      |      |      |      |
|                       | Power frequency permissible fluctuation | ±5%   |                    |      |      |      |      |
|                       | Power source capacity (kVA)             | 1.5   | 2.5                | 4.5  | 6.9  | 10.4 | 11.5 |
| Cooling method        |   | Self cooling  | Forced air cooling |      |      |      |      |
| Inverter weight (kg)  |   | 0.74  | 0.74               | 0.81 | 1.37 | 1.37 | 1.42 |

3.1.2 220Vseries three-phase

| Frame                 |   | A   |                    |      | B    |      |      |
|-----------------------|---|---|--------------------|------|------|------|------|
| Model SC3-023-□□□K-□□ |   | 0.2   | 0.4                | 0.75 | 1.5  | 2.2  | 3.7  |
| Output                | Rated output capacity (kVA)             | 0.6   | 1.2                | 2    | 3.2  | 4.2  | 6.7  |
|                       | Rated output current(A)                 | 1.8   | 3                  | 5    | 8    | 11   | 17.5 |
|                       | Applicable motor capacity (HP)          | 0.25  | 0.5                | 1    | 2    | 3    | 5    |
|                       | Applicable motor capacity (kW)          | 0.2   | 0.4                | 0.75 | 1.5  | 2.2  | 3.7  |
|                       | Overload current rating                 | 150% 60seconds 200% 1 second inverse time characteristics |                    |      |      |      |      |
|                       | Carrier frequency (kHz)                 | 1~15kHz   |                    |      |      |      |      |
|                       | Maximum output voltage                  | Three-phase 200-240V                                      |                    |      |      |      |      |
| Power supply          | Rated power voltage                     | Three-phase 200-240V 50Hz / 60Hz                          |                    |      |      |      |      |
|                       | Power voltage permissible fluctuation   | Three-phase 170-264V 50Hz / 60Hz                          |                    |      |      |      |      |
|                       | Power frequency permissible fluctuation | ±5%   |                    |      |      |      |      |
|                       | Power source capacity (kVA)             | 0.75  | 1.5                | 2.5  | 4.5  | 6.4  | 10   |
| Cooling method        |   | Self cooling  | Forced air cooling |      |      |      |      |
| Inverter weight (kg)  |   | 0.69  | 0.69               | 0.70 | 0.73 | 1.32 | 1.4  |

## 3.1.3 220Vseries single-phase

| Frame                 |   | A   |                    |      | B    |     |
|-----------------------|---|---|--------------------|------|------|-----|
| Model SC3-021-□□□K-□□ |   | 0.2   | 0.4                | 0.75 | 1.5  | 2.2 |
| Output                | Rated output capacity (kVA)             | 0.6   | 1                  | 1.5  | 2.5  | 4.2 |
|                       | Rated output current(A)                 | 1.8   | 2.7                | 4.5  | 8    | 11  |
|                       | Applicable motor capacity (HP)          | 0.25  | 0.5                | 1    | 2    | 3   |
|                       | Applicable motor capacity (kW)          | 0.2   | 0.4                | 0.75 | 1.5  | 2.2 |
|                       | Overload current rating                 | 150% 60seconds 200% 1 second inverse time characteristics |                    |      |      |     |
|                       | Carrier frequency (kHz)                 | 1~15kHz   |                    |      |      |     |
|                       | Maximum output voltage                  | Three-phase 200-240V                                      |                    |      |      |     |
| Power supply          | Rated power voltage                     | Single-phase 200-240V 50Hz / 60Hz                         |                    |      |      |     |
|                       | Power voltage permissible fluctuation   | Single-phase 170-264V 50Hz / 60Hz                         |                    |      |      |     |
|                       | Power frequency permissible fluctuation | ±5%   |                    |      |      |     |
|                       | Power source capacity (kVA)             | 0.75  | 1.5                | 2.5  | 3.5  | 6.4 |
| Cooling method        |   | Self cooling  | Forced air cooling |      |      |     |
| Inverter weight (kg)  |   | 0.66  | 0.68               | 0.73 | 1.38 | 1.4 |

## 3.2 General specification

|   |                         |   |   |
|---|-------------------------|---|---|
| Control method                                    |                         | SVPWM control, V/F control, General magnetic vector control   |   |
| Output frequency range                            |                         | 0~650.00Hz  |   |
| Frequency setting resolution                      | Digital setting         | The frequency is set within 100Hz, the resolution is 0.01Hz.  |   |
|   |                         | The frequency is set more than 100Hz, the resolution is 0.1Hz.  |   |
|   | Analog setting          | DC 0~5V or 4~20mA signal, 11 bit.   |   |
|   |                         | DC 0~10V signal, 12 bit.  |   |
| Output frequency accuracy                         | Digital setting         | Maximum target frequency $\pm 0.01\%$ .   |   |
|   | Analog setting          | Maximum target frequency $\pm 0.1\%$ .  |   |
| Start torque                                      |                         | 180% 3Hz, 200% 5Hz : Under the condition of general magnetic vector control   |   |
| V/F characteristics                               |                         | Constant torque curve, variable torque curve, five-point curve  |   |
| Acceleration / deceleration curve characteristics |                         | Linear acceleration / deceleration curve, S pattern acceleration / deceleration curve 1 & 2 & 3   |   |
| Drive motor                                       |                         | Induction motor (IM)  |   |
| Stalling protection                               |                         | The stalling protection level can be set to 0~250 % (06-01(P.22)). The default value is 200%.   |   |
| Target frequency setting                          |                         | Operation panel setting, DC 0~5V/10V signal, DC 4~20 mA signal, multiple speed stage level setting, communication setting.  |   |
| Operation panel                                   | Operation monitoring    | Output frequency, output current, output voltage, PN voltage, electronic thermal accumulation rate, temperature rising accumulation rate, output power, analog value input signal, output terminal status...; alarm history 12 groups at most, the last group of alarm message is recorded. |   |
|   | LED indication lamp (6) | frequency monitoring indication lamp, voltage monitoring indication lamp, current monitoring indication lamp, motor operation lamp, mode switching lamp, PU control indication lamp   |   |
| Communication function                            |                         | RS-485 communication can select Shihlin/Modbus communication protocol, communication speed 115200bps or lower.  |   |
| Protection mechanism / alarm function             |                         | Output short circuit protection, Over-current protection, over-voltage protection, under-voltage protection, motor over-heat protection (06-00(P.9)), IGBT module over-heat protection, communication abnormality protection...   |   |
| Environment                                       |                         | Ambient temperature   | -10 ~ +50°C (non-freezing)  |
|   |                         | Ambient humidity  | Below 90%Rh (non-condensing).   |
|   |                         | Storage temperature   | -20 ~ +65°C.  |
|   |                         | Surrounding environment   | Indoor, no corrosive gas, no flammable gas, no flammable powder.                                  |
|   |                         | Altitude  | Altitude below 2000 meters, when altitude is above 1,000 m, derate the rated current 2% per 100 m |
|   |                         | Vibration   | Vibration below 5.9m/s <sup>2</sup> (0.6G).   |
|   |                         | Grade of protection   | IP20  |
|   |                         | The degree of environmental pollution   | II  |
|   |                         | environmental pollution degree  | 2   |
|   |                         | Class of protection   | Class I   |
| International certification                       |                         | CE  |   |

### 3.3 Appearance and dimensions

#### 3.3.1 Frame A

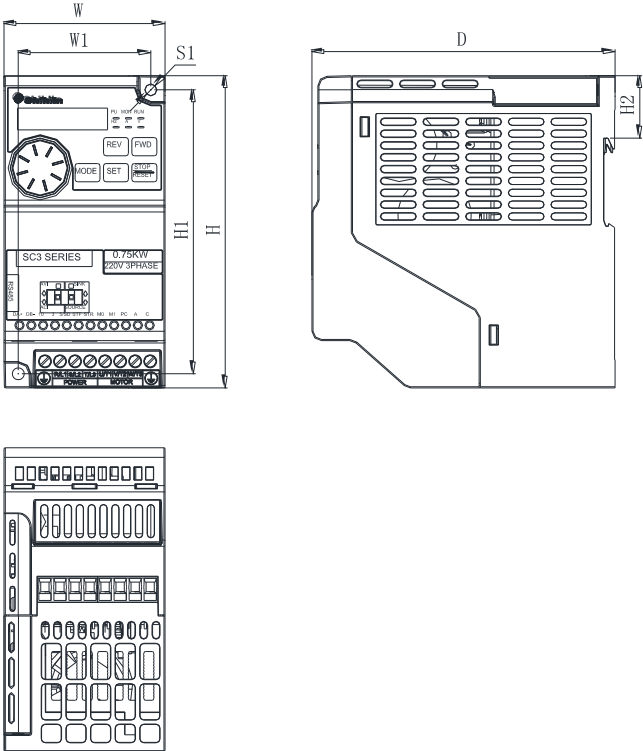

| Model         | W  | W1 | H   | H1  | H2   | D   | Unit:mm |
|---------------|----|----|-----|-----|------|-----|---------|
|               |    |    |     |     |      |     | S1      |
| SC3-021-0.2K  | 68 | 56 | 132 | 120 | 26.5 | 128 | 5       |
| SC3-021-0.4K  |    |    |     |     |      |     |         |
| SC3-021-0.75K |    |    |     |     |      |     |         |
| SC3-023-0.2K  |    |    |     |     |      |     |         |
| SC3-023-0.4K  |    |    |     |     |      |     |         |
| SC3-023-0.75K |    |    |     |     |      |     |         |
| SC3-023-1.5K  |    |    |     |     |      |     |         |
| SC3-043-0.4K  |    |    |     |     |      |     |         |
| SC3-043-0.75K |    |    |     |     |      |     |         |
| SC3-043-1.5K  |    |    |     |     |      |     |         |

3.3.2 Frame B

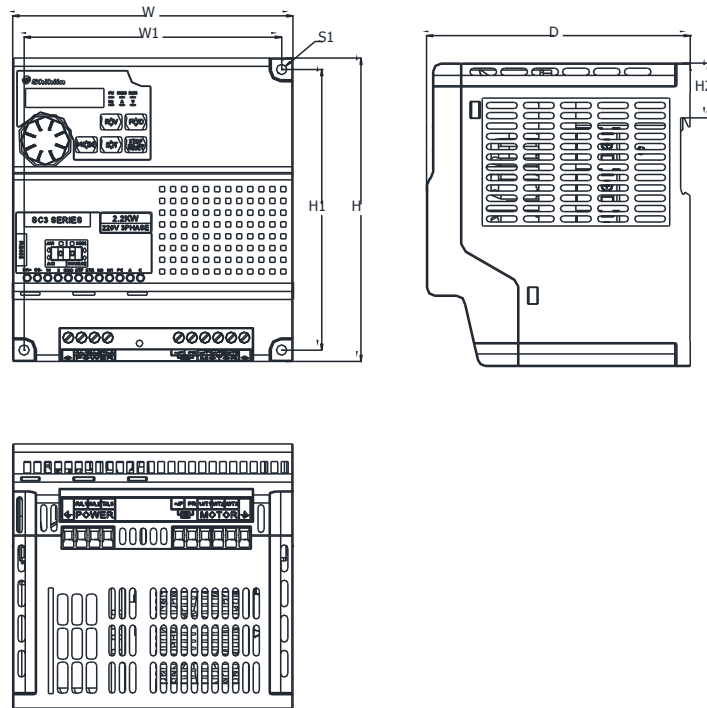

Unit: mm

| Model        | W   | W1  | H   | H1  | H2   | D   | S1 |
|--------------|-----|-----|-----|-----|------|-----|----|
| SC3-021-1.5K | 136 | 125 | 147 | 136 | 26.5 | 128 | 5  |
| SC3-021-2.2K |     |     |     |     |      |     |    |
| SC3-023-2.2K |     |     |     |     |      |     |    |
| SC3-023-3.7K |     |     |     |     |      |     |    |
| SC3-043-2.2K |     |     |     |     |      |     |    |
| SC3-043-3.7K |     |     |     |     |      |     |    |
| SC3-043-5.5K |     |     |     |     |      |     |    |

### 3.4 Name of each component

#### 3.4.1 Frame A/B

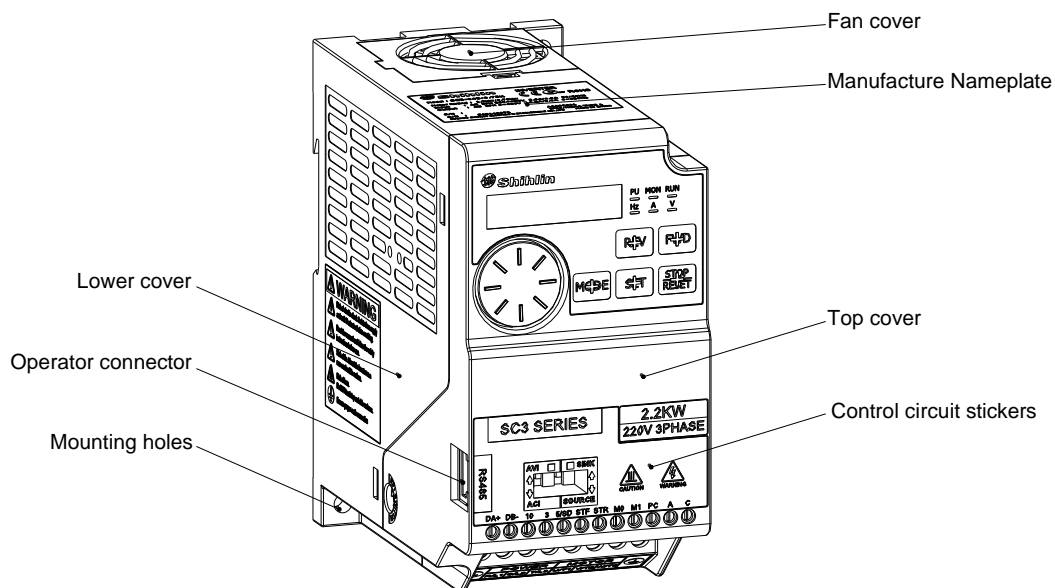

### 3.5 Installation and wiring

#### 3.5.1 Transportation

Take the pedestal when carrying and don't only take the cover or any part of the inverter, otherwise it may drop down.

#### 3.5.2 Storage

Keep this product in the packaging before installation and when not in use. To change the frequency that meets the manufacturer's warranty and maintenance conditions, please pay attention to the following regarding storage:

1. Must be placed in dry and without dirt place.
2. The environment temperature for storage position must range from -20°C to +65°C.
3. The relative humidity for storage position must range from 0% to 95%, and no condensation.
4. Avoid storing in the environment which contains corrosion gas or liquid.
5. It had better be packed properly and kept on shelf or table.

Note: 1. Even if the humidity meets the standard requirements, icing and condensation can also occur when the temperature changes rapidly. And the place should avoid.

2. Don't place it on the ground, and it should be placed on appropriate shelf. If in the bad surroundings, the desiccant should be placed in the packaging bag.

3. If the custody period is more than 3 months, the ambient temperature should not be higher than 30°C. It is to consider that the character will easily degrade in high temperature when the electrolytic capacitors are deposited without electricity.

4. If the inverter is installed in device or control board when not in use (especially in construction site or the humid and dusty place), the inverter should be removed and put in suitable environment according with the above storage conditions.

5. If the electrolytic capacitors are long-term no electricity, the character will degrade. Do not place it in the state of no electricity for more than one year.

#### 3.5.3 Installation notice

✓ Before installation, please confirm whether meet the conditions listed in the table below:

|                         |  |
|-------------------------|--|
| Ambient temperature     | -10 ~ +50°C (non-freezing)   |
| Ambient humidity        | 90%Rh 以下(non-condensing).  |
| Storage temperature     | -20 ~ +65°C.   |
| Surrounding environment | Indoor, no corrosive gas, no flammable gas, no flammable powder.                                   |
| Altitude                | Altitude below 2000 meters, when altitude is above 1,000 m, derate the rated current 2% per 100 m. |
| Vibration               | Vibration below 5.9m/s <sup>2</sup> (0.6G).  |
| Grade of protection     | IP20   |
| Class of protection     | 2  |

✓ Please ensure vertical arrangement to keep the cooling effect:

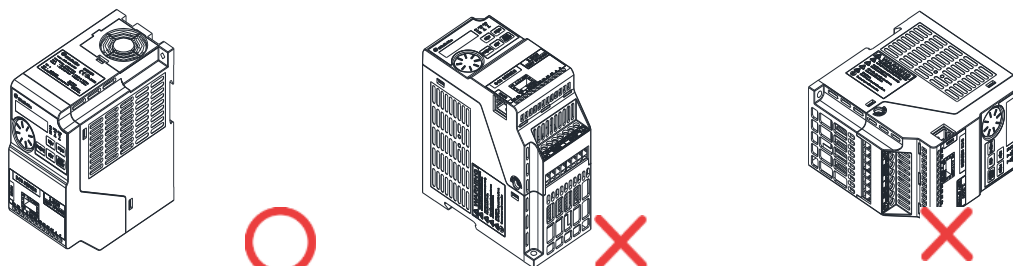

(a) Vertical arrangement (b) Horizontal arrangement (c) Level arrangement

✓ Please comply with installation conditions shown below to ensure enough ventilation space and wiring space for inverter cooling:

- Arrangement of single or paralleling inverter:

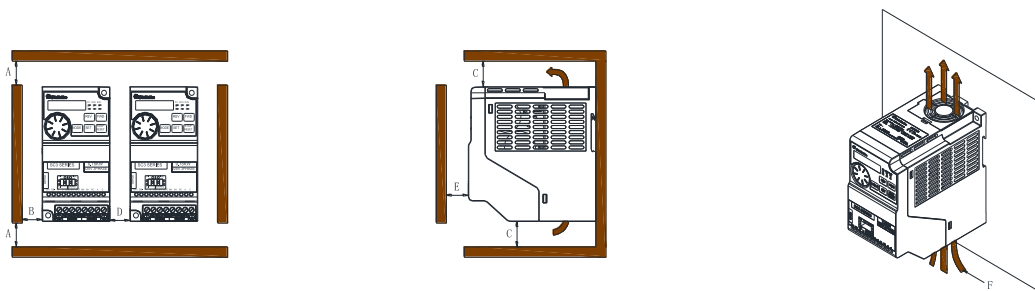

| Size | Frame A       | Frame B |
|------|---------------|---------|
| A    | 50            | 50      |
| B    | 50            | 50      |
| C    | 100           | 100     |
| D    | 50            | 50      |
| E    | 50            | 50      |
| F    | Air direction |         |

- Arrangement of multiple inverters:

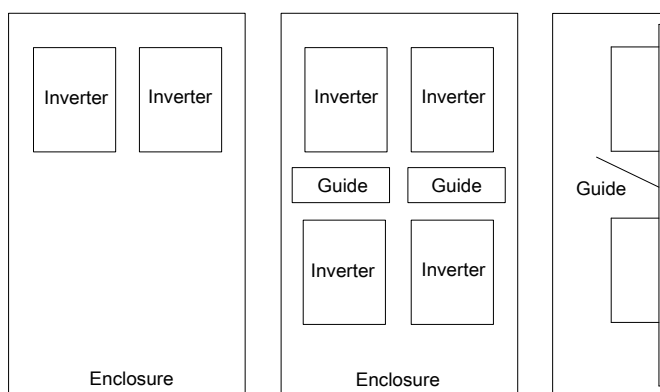

(a) Horizontal arrangement (b) Vertical arrangement

Note1. When mounting inverters of different sizes in parallel, please align the clearance above each inverter to install, which is easy to change the cooling fan

2. When it is inevitable to arrange inverters vertically to minimize space, take such measures as to provide guides since heat from the bottom inverters can increase the temperatures in the top inverters, causing inverter failures.

- Installation of DIN rail :

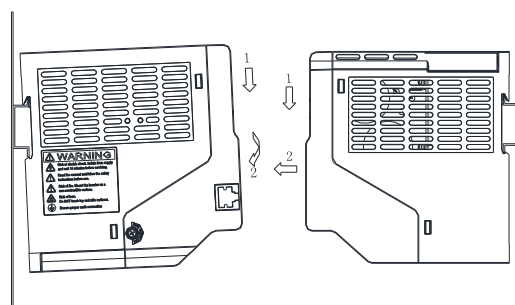

(a) Installation

(b) Disassembly

### 3.5.4 EMC installation instructions

Just as other electrical and electronic equipments, an inverter is the source of electromagnetic interference and an electromagnetic receiver when working with a power system. The amount of electromagnetic interference and noise is determined by the working principles of an inverter. In order to guarantee the inverter working reliably in the electromagnetic environment, it must have a certain ability of anti-electromagnetic interference in design. In order to make the drive system work normally, please meet the following several aspects requirements in installation:

✓ **Field wiring**

Power line supply electric independently from power transformer, five or four core line are generally used, null line and ground sharing a single line is forbidden.

Commonly signal wire (weak) and power wire (heavy) are in control cabinet, for the inverter, power wire is divided into input line and output line. Signal wire is easily interfered by power wire, so that causing the disoperation of the device. When wiring, signal wire and power wire should be distributed in different areas, parallel lines and interlaced lines are forbidden at close range(within 20cm), and especially don't bundle up the two lines. If the signal cables must pass via the power lines, the two should keep 90 degree Angle. Interlace lines and banding together is also forbidden for the input and output line of power wire, especially on the occasions which noise filter is installed. It will cause the coupling of electromagnetic noise via the distributed capacitance of the input and output lines, thus the noise filter will out of action.

Generally a control cabinet has different electric equipments such as inverter, filter, PLC, measurement instrument, their ability of emitting and bearing electromagnetic noise are diverse from each other, and this requires classifying these equipments. The classification can be divided into strong noise equipment and noise sensitive equipment, Install the similar equipments in the same area and, and keep a distance more than 20cm among inhomogeneous equipments.

✓ **Input noise filter, input and output magnet ring (Zero phase reactor)**

Adding noise filter to the input terminal, the inverter will be isolated from the other equipments, and its ability of conduction and radiation will be reduced effectively. The better EMI suppression effect will be obtained by installing the input reactor recommended by this manual. By adding winding ferrite bead to the input and output terminal and coordinating with internal filter, the inverters will have a better effect.

✓ **Shielding**

Good shielding and grounding can greatly reduce the interference of inverter, and can improve the anti-interference ability of the inverter. Sealing off the inverter with the good conductive sheet metal and connecting the sheet metal to ground, the radiation interference will be reduced effectively. To reduce the interference of inverter and improve the anti-interference ability, cable with shielding layer should be used in input and output and the both ends of it should be connected to ground. Shielding cable is suggested to be used in control connecting and communication connecting of the inverter external terminals under bad electromagnetic environment. Generally, the both ends of shielding layer should be connected to the control /communication ground, and they can also be connected to ground.

✓ **Grounding**

The inverter must be connected to the ground safely and reliably. Grounding is not only for equipment and personal safety, but also the simplest, the most efficient and the lowest cost method to solving the EMC problem, so it should be prioritized. Please refer to the section of "3.7 Terminal wiring".

✓ **Carrier wave**

The leakage current contains the leakage current from line to line or over the ground. It depends on the size of the distributed capacitance when wiring and the carrier frequency of the frequency. The higher the carrier frequency, the longer the motor cable, and the larger the cable cross-sectional area is, the larger the leakage current is. Reducing the carrier frequency can effectively reduce the leakage current. When the motor line is long (50m above), the output side should be installed with ac reactor or sine wave filter, when the motor line is longer, a reactor should be installed every other distance. At the same time, reducing carrier frequency can effectively reduce the conduction and radiation interference.

### 3.6 Peripheral devices

#### 3.6.1 System Wire Arrangement

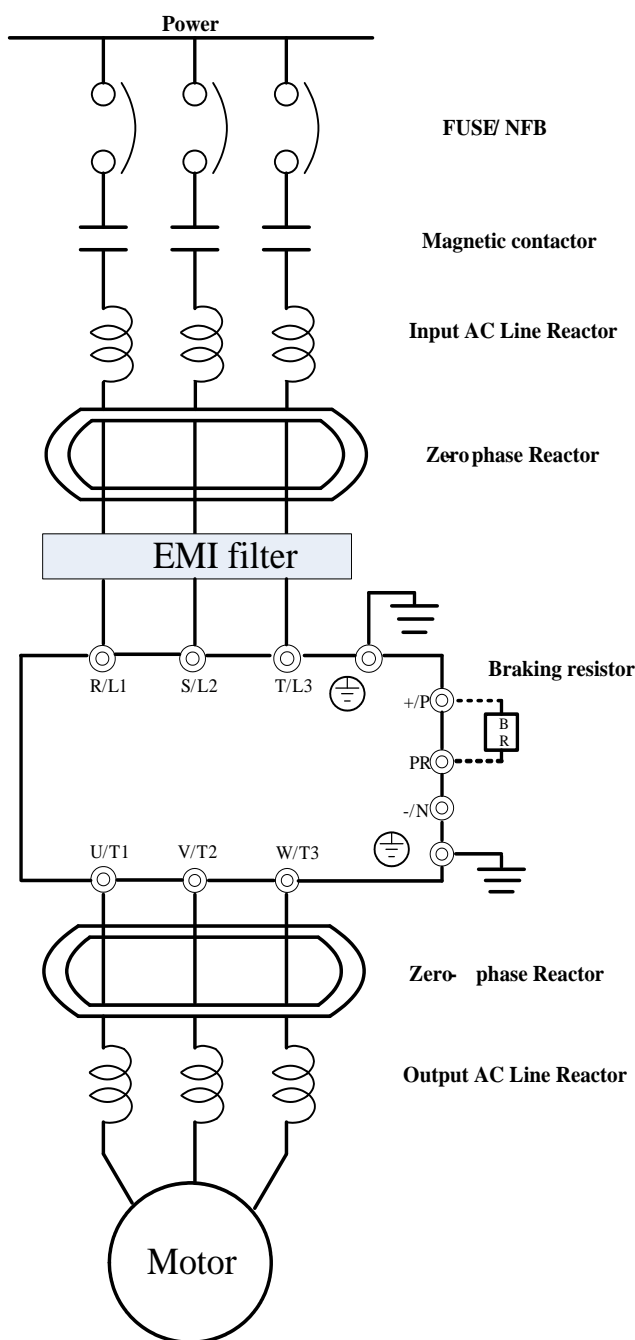

|                        |   |
|------------------------|---|
| Power supply           | Please follow the specific power supply requirement shown in this manual.   |
| Fuse/NFB               | There may be an inrush current during power up. Please refer to 3.6.2 and select the correct fuse /NFB.   |
| Magnetic contactor     | Please do not use a Magnetic contactor as the I/O switch of the inverter, as it will reduce the operating life cycle of the inverter.   |
| Input AC Line Reactor  | AC line reactor should be installed to improve the input power factor. The wiring distance should be less than 10m.   |
| Zero-phase Reactor     | Zero-phase reactors are used to reduce radio noise especially when audio equipment installed near the inverter. Effective for noise reduction on both the input and output sides. Attenuation quality is good for a wide range from AM band to 10MHz. |
| EMI filter             | Used to reduce electromagnetic interference.  |
| Braking unit           | Used to reduce stopping time of the motor.  |
| Output AC Line Reactor | Motor surge voltage amplitudes depending on motor cable length. The output AC line reactor is necessary to install on the inverter output side.   |

## 3.6.2 No-fuse switch and magnetic contactor

| Inverter model | Motor capacity | Power source capacity | Applicable no-fuse switch (NFB/MCCB) type (Shihlin Electric) | Applicable electromagnetic contactor (MC) type (Shihlin Electric) |
|----------------|----------------|-----------------------|--|---|
| SC3-043-0.4K   | 440V 0.5HP     | 1 kVA                 | BM30SN3P3A   | S-P11   |
| SC3-043-0.75K  | 440V 1HP       | 2kVA                  | BM30SN3P5A   | S-P11   |
| SC3-043-1.5K   | 440V 2HP       | 3kVA                  | BM30SN3P10A  | S-P11   |
| SC3-043-2.2K   | 440V 3HP       | 2.5kVA                | BM30SN3P15A  | S-P21   |
| SC3-043-3.7K   | 440V 5HP       | 4.5kVA                | BM30SN3P20A  | S-P21   |
| SC3-043-5.5K   | 440V 7.5HP     | 6.4kVA                | BM30SN3P30A  | S-P21   |
| SC3-023-0.2K   | 220V 0.25HP    | 0.25kVA               | BM30SN3P5A   | S-P11   |
| SC3-023-0.4K   | 220V 0.5HP     | 0.5kVA                | BM30SN3P5A   | S-P11   |
| SC3-023-0.75K  | 220V 1HP       | 1 kVA                 | BM30SN3P10A  | S-P11   |
| SC3-023-1.5K   | 220V 2HP       | 2 kVA                 | BM30SN3P15A  | S-P11   |
| SC3-023-2.2K   | 220V 3HP       | 3 kVA                 | BM30SN3P20A  | S-P11 / S-P12   |
| SC3-023-3.7K   | 220V 5HP       | 5 kVA                 | BM30SN3P30A  | S-P21   |
| SC3-021-0.2K   | 220V 0.25HP    | 52 kVA                | BM30SN3P5A   | S-P11   |
| SC3-021-0.4K   | 220V 0.5HP     | 65 kVA                | BM30SN3P5A   | S-P11   |
| SC3-021-0.75K  | 220V 1HP       | 79 kVA                | BM30SN3P10A  | S-P11   |
| SC3-021-1.5K   | 220V 2HP       | 99 kVA                | BM30SN3P15A  | S-P11   |
| SC3-021-2.2K   | 220V 3HP       | 110kVA                | BM30SN3P20A  | S-P11/ S-P12  |

### 3.6.3 Brake Resistor

| Inverter model | Brake resistor specification |
|----------------|------------------------------|
| SC3-043-2.2K   | 300W 160Ω                    |
| SC3-043-3.7K   | 500W 120Ω                    |
| SC3-043-5.5K   | 1000W 75Ω                    |
| SC3-023-2.2K   | 300W 60Ω                     |
| SC3-023-3.7K   | 400W 40Ω                     |
| SC3-021-1.5K   | 300W 60Ω                     |
| SC3-021-2.2K   | 300W 60Ω                     |

Note: 1. For brake resistor whose built-in brake unit offers model options, the capacity of the regenerative brake is based on the condition that the regenerative brake duty is 10% (when braking lasts for 5 seconds, the machine has to be stopped for another 45 seconds must be stopped for heat dissipation). For models without a built-in brake unit, the capacity of the regenerative brake is based on the brake duty of the selected brake unit. The regenerative brake resistor wattage can be reduced according to the user's application (quantity of heat) and the regenerative brake duty. But the resistance must be larger than the value (ohms) listed in the above table (otherwise the inverter will be damaged).

2. In case frequent start and stop operations are required, a larger regenerative brake duty should be set. Meanwhile, a large brake resistor should be employed correspondingly. Please feel free to contact us if there is any problem regarding the selection of brake resistors.

### 3.7 Terminal wire arrangement

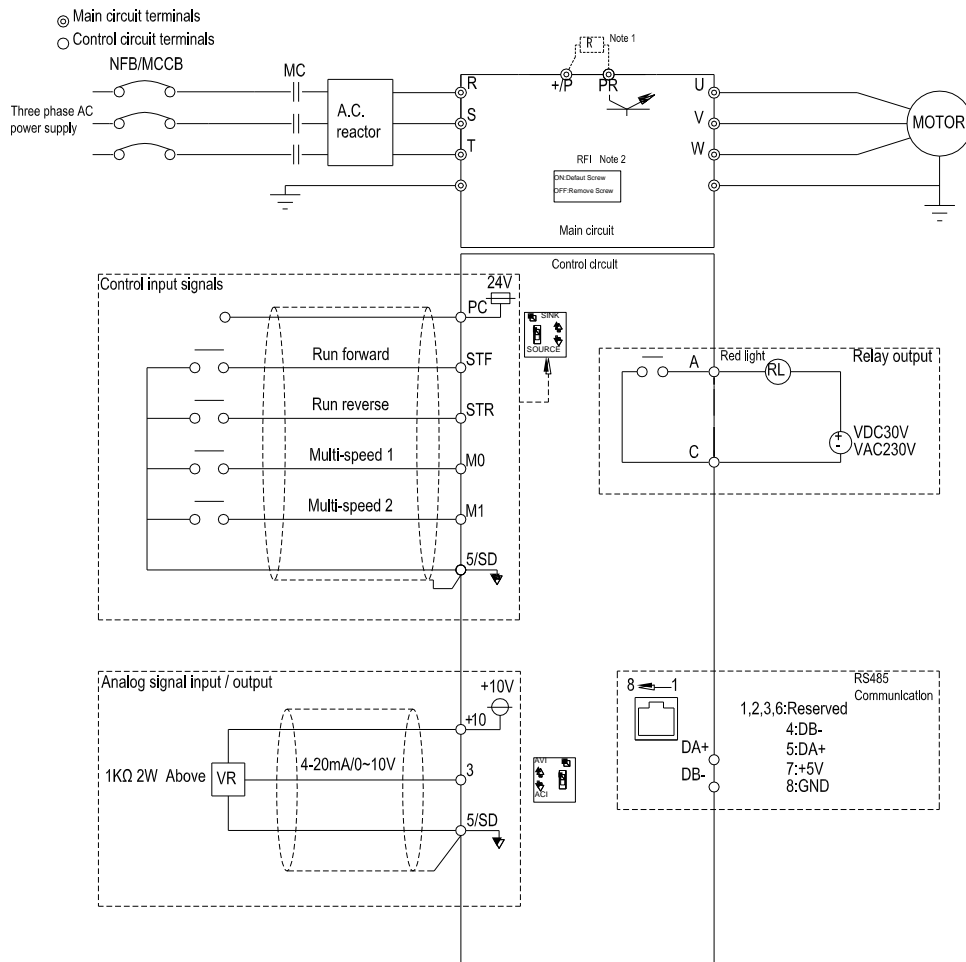

Note 1 : SC3-043-0.4K~1.5K , SC3-023-0.2~1.5K , SC3-021-0.2~0.75K have not +/P and PR terminals.

Note 2 : Full range of built-in RFI filter to suppress electromagnetic interference, but if you want to meet CE standard, please refer to the instructions in the operating manual for installation.

### 3.7.1 Main circuit Terminals

#### ✓ Description

| Terminal symbol   | Description  |
|---|--|
| R/L1-S/L2-T/L3  | Connect to the commercial power supply                           |
| U/T1-V/T2-W/T3  | Connect to the three-phase squirrel-cage motor.                  |
| (+P)-PR   | Connect to the brake resistor. (B framework built-in brake unit) |
|  | ground terminal  |

Note: 1.Frame A don't have built-in brake unitand the terminals +/P and PR.

#### ✓ Terminal layout of the main circuit terminals

- Frame A

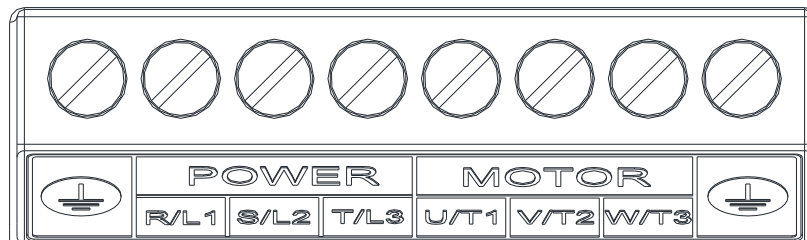

- Frame B

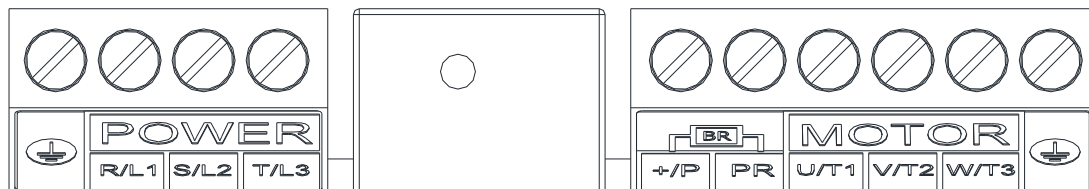

#### ✓ Brake resistor connection

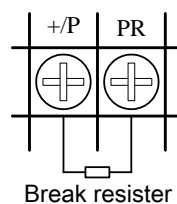

Note: It is only suitable for frame B corresponded inverters. Please refer to Section 3.3 for instruction on the frames.

## 3.7.2 Main circuit wiring and terminal specification

| Inverter model | Terminal screw specifications | Tightening torque (Kgf.cm) | Recommended wiring specification (mm <sup>2</sup> ) |       |     |                 | Recommended wiring specification (AWG) |       |     |                 |
|----------------|-------------------------------|----------------------------|---|-------|-----|-----------------|--|-------|-----|-----------------|
|                |                               |                            | R,S,T   | U,V,W | +/P | Grounding Cable | R,S,T                                  | U,V,W | +/P | Grounding Cable |
| SC3-021-0.2K   | M3                            | 4~6                        | 2.5   | 1.5   | --- | 1.5             | 14                                     | 16    | --- | 16              |
| SC3-023-0.2K   |                               |                            | 1.5   | 1.5   | --- | 1.5             | 16                                     | 16    | --- | 16              |
| SC3-043-0.4K   |                               |                            | 1.5   | 1.5   | --- | 1.5             | 16                                     | 16    | --- | 16              |
| SC3-021-0.4K   |                               |                            | 2.5   | 2.5   | --- | 2.5             | 14                                     | 14    | --- | 14              |
| SC3-023-0.4K   |                               |                            | 2.5   | 2.5   | --- | 2.5             | 14                                     | 14    | --- | 14              |
| SC3-043-0.75K  |                               |                            | 2.5   | 2.5   | --- | 2.5             | 14                                     | 14    | --- | 14              |
| SC3-021-0.75K  |                               |                            | 2.5   | 2.5   | --- | 2.5             | 14                                     | 14    | --- | 14              |
| SC3-023-0.75K  |                               |                            | 2.5   | 2.5   | --- | 2.5             | 14                                     | 14    | --- | 14              |
| SC3-043-1.5K   |                               |                            | 2.5   | 2.5   | --- | 2.5             | 14                                     | 14    | --- | 14              |
| SC3-023-1.5K   |                               |                            | 2.5   | 2.5   | --- | 2.5             | 14                                     | 14    | --- | 14              |
| SC3-021-1.5K   |                               |                            | 2.5   | 2.5   | 2.5 | 2.5             | 14                                     | 14    | 14  | 14              |
| SC3-043-2.2K   |                               |                            | 2.5   | 2.5   | 2.5 | 2.5             | 14                                     | 14    | 14  | 14              |
| SC3-021-2.2K   |                               |                            | 4   | 4     | 4   | 4               | 12                                     | 12    | 12  | 12              |
| SC3-023-2.2K   |                               |                            | 4   | 4     | 4   | 4               | 12                                     | 12    | 12  | 12              |
| SC3-043-3.7K   |                               |                            | 2.5   | 2.5   | 2.5 | 2.5             | 10                                     | 14    | 14  | 14              |
| SC3-043-5.5K   |                               |                            | 2.5   | 2.5   | 2.5 | 2.5             | 14                                     | 14    | 14  | 14              |
| SC3-023-3.7K   |                               |                            | 4   | 4     | 4   | 4               | 12                                     | 12    | 12  | 12              |

Note: 1. Don't directly connect power input line with motor terminals (U/T1) - (V/T2) - (W/T3) of the converter, otherwise will cause the damage of the inverter.

2. Don't add into the phase capacitor, surge absorber and electromagnetic contactor on the output of the inverter.

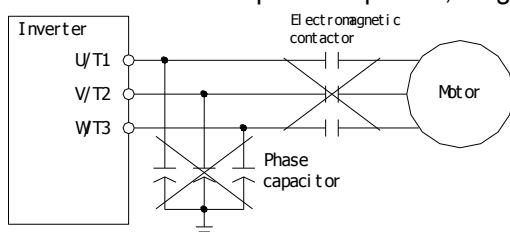

- Do not use the power of the online "electromagnetic contactor" or "no fuse switch" to start and stop the motor.
- Please do implement chassis grounding of the inverter and motor, avoiding electric shock.
- The specifications of the no-fuse switch and the electromagnetic contactor please refer to the section 3.6.2.
- If the distance between the inverter and motor is longer, please use thick wires, make sure wire pressure dropping under 2V (wire length below 500 meters).
- The connection of the power supply side and load side use "insulation sleeve crimping terminal".
- After terminal power outage, in a short time, high voltage still exists. Within 10 minutes, do not touch terminals, in order to avoid electric shock.

### 3.7.3 Ground

For safety and to reduce noise, the grounding terminal  of the inverter must be well grounded. To avoid electric shocks and fire accident, external metal wire of electrical equipment should be short and thick, and should be connected to special grounding terminals of an inverter. If several inverters are placed together, all inverters must be connected to the common ground. Please refer to the following diagrams and ensure that no circuit is formed between grounding terminals.

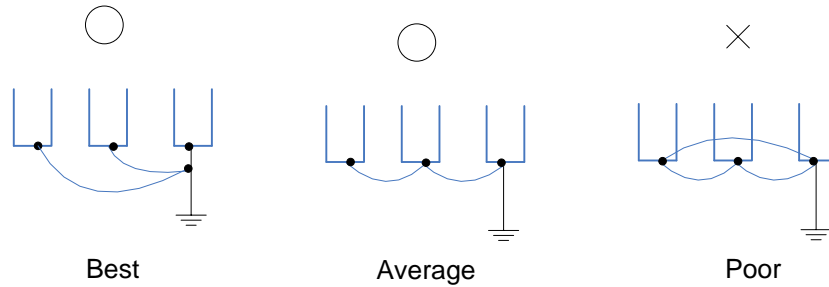

### 3.7.4 RFI filter

The inverters of SC3 series are equipped with built-in RFI filters. These filters are effective in reducing electromagnetic interference, but if in line with CE standard, please refer to Section 3.5.4 for installation and wiring.

#### ✓ Frame A/B

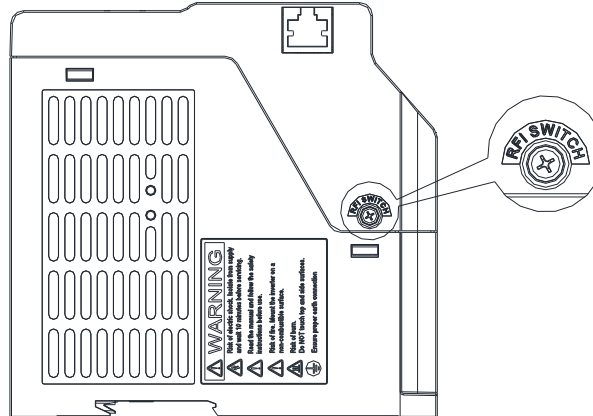

Frame A/B

RFI filter ON: screws fastened tightly (default status)

RFI filter OFF: screws loosened

| Frame | Screw | Torque   |
|-------|-------|----------|
| A     | M3*10 | 25kgf.cm |
| B     | M3*14 | 25kgf.cm |

## 3.7.5 Control circuit

## ✓ Control terminal name

| Terminal type          | Terminal name | Function instructions  | Terminal specifications  |
|------------------------|---------------|--|--|
| Digital signal input   | STF           | There are totally 4 multi-function control terminals, which can switch mode of SINK/SOURCE.          | Input impedance: 4.7 kΩ<br>Action current: 5mA(when 24VDC)<br>Voltage range: 10~28VDC<br>Maximum frequency: 1kHz                 |
|                        | STR           |  |  |
|                        | M0            |  |  |
|                        | M1            |  |  |
| Analog signal input    | 10            | +10.5±0.5V   | Maximum current:10mA   |
|                        | 3             | 0~10V/4~20mA   | Input impedance:10 kΩ  |
| Relay output           | A             | Multi-function relay output terminals.<br>A-C is the normally open contact,<br>C is common terminal. | Maximum voltage: 30VDC or 250VAC<br>Maximum current:<br>Resistor load 5A NO/3A NC<br>Inductance load 2A NO/1.2A NC<br>(cosΦ=0.4) |
|                        | C             |  |  |
| Communication terminal | RJ45          | RS-485, optical isolation<br>RJ45 and "DA+/DB-" cannot be used at the same time.                     | Highest rate:115200bps<br>Longest distance:500m  |
|                        | DA+           |  |  |
|                        | DB-           |  |  |
| Common terminal        | 5/SD          | The common terminal of STF,STR, M0, M1, 3 terminals, in SINK mode                                    | ---  |
|                        | PC            | The common terminal of terminal STF, STR, M0, M1 in SOURCE mode                                      | ---  |

## ✓ Control logic (SINK/SOURCE) change

The multi-function control terminal of SC3 series inverter can select the sink input approach or the source input approach via the toggle switch. The diagram is as follows

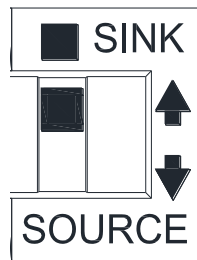

No matter what kind of multi-function control terminal is, all of its outside wire arrangement can be considered as a simple switch. If the switch is "on", the control signal will be put into the terminal. If the switch is "off," the control signal is shut off.

If "Sink Input" mode is selected, the function of the terminal is active when it is shorted with SD or connected with the external PLC. In this mode, the current flows out of the corresponding terminal when it is "on". Terminal "SD" is common to the contact input signals. When using an external power supply for output transistor, please use terminal PC as a common to prevent disoperation caused by leakage current.

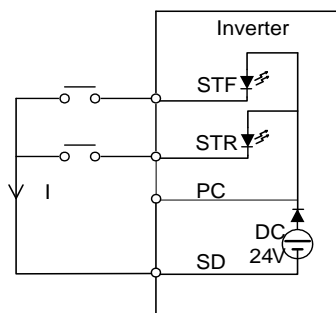

Sink Input: the multi-function control terminal is shorted directly with SD

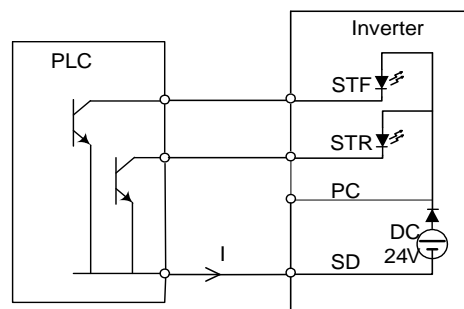

Sink Input: the multi-function control terminal is connected directly with open-collector PLC

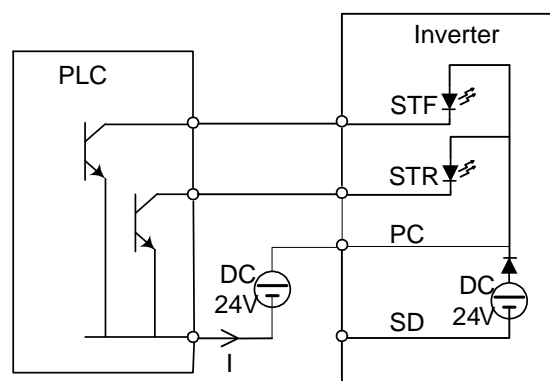

Sink Input: the multi-function control terminal is connected with open-collector PLC and external power supply

If "Source Input" mode is selected, the function of the terminal is active when it is shorted with PC or connected with the external PLC. In this mode, the current flows into the corresponding terminal when it is "on". Terminal PC is common to the contact input signals. When using an external power supply for transistor, please use terminal SD as a common to prevent disoperation caused by leakage current.

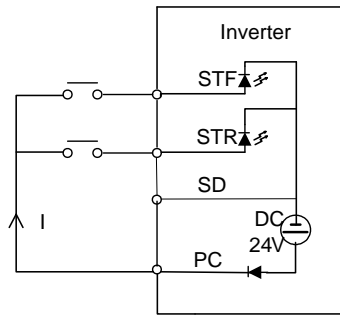

Source Input: the multi-function control terminal is shorted directly with PC

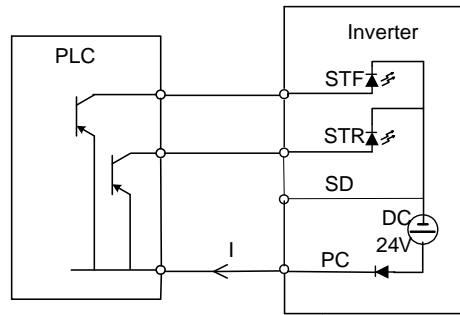

Source Input: the multi-function control terminal is connected directly with open-emitter PLC

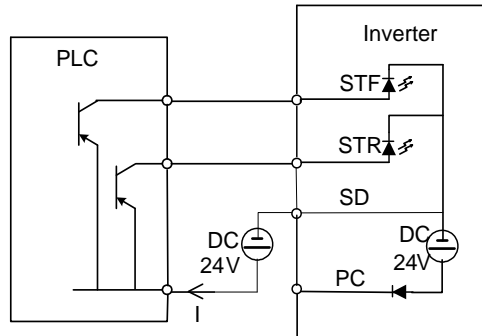

Source Input: the multi-function control terminal is connected with open-emitter PLC and external power supply

## ✓ Arrangement of control terminal

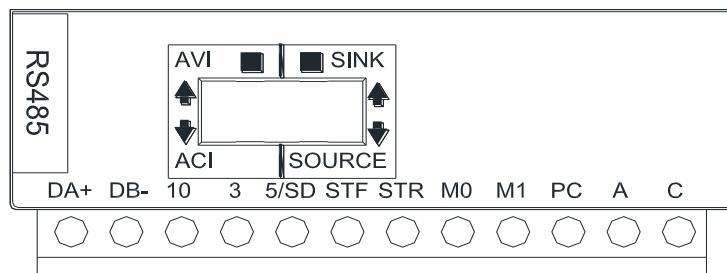

### ● Power supply connection

For the control circuit wiring, strip off the sheath of a cable, and use it with a blade terminal. For a single wire, strip off the sheath of the wire and apply directly.

- (1) Strip off the sheath for the below length. If the length of the sheath peeled is too long, a short circuit may occur with neighboring wires. If the length is too short, wires might come off.

Wire the stripped cable after twisting it to prevent it from becoming loose. In addition, do not solder it.



- (2) Crimp the blade terminal.

Insert wires to a blade terminal, and check that the wires come out for about 0 to 0.5 mm from a sleeve.

Check the condition of the blade terminal after crimping. Do not use a blade terminal of which the crimping is inappropriate, or the face is damaged.

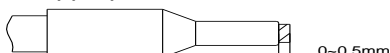

- Please do use blade terminals with insulation sleeve. Blade terminals commercially available:

| Cable gauge (mm <sup>2</sup> ) | Blade terminals model  | L (mm) | d1 (mm) | d2 (mm) | Manufacturer                    | Crimping tool product |
|--------------------------------|------------------------|--------|---------|---------|---------------------------------|-----------------------|
| 0.3                            | AI 0,25-6 WH           | 10.5   | 0.8     | 2       | Phoenix<br>Contact<br>Co., Ltd. | CRIMPFOX 6            |
| 0.5                            | AI 0,5-6 WH            | 12     | 1.1     | 2.5     |                                 |                       |
| 0.75                           | AI 0,75-6 GY           | 12     | 1.3     | 2.8     |                                 |                       |
| 0.75<br>(for two wires)        | AI-TWIN<br>2×0,75-6 GY | 12     | 1.3     | 2.8     |                                 |                       |

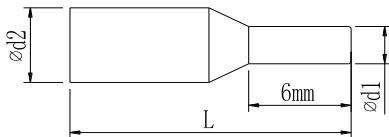



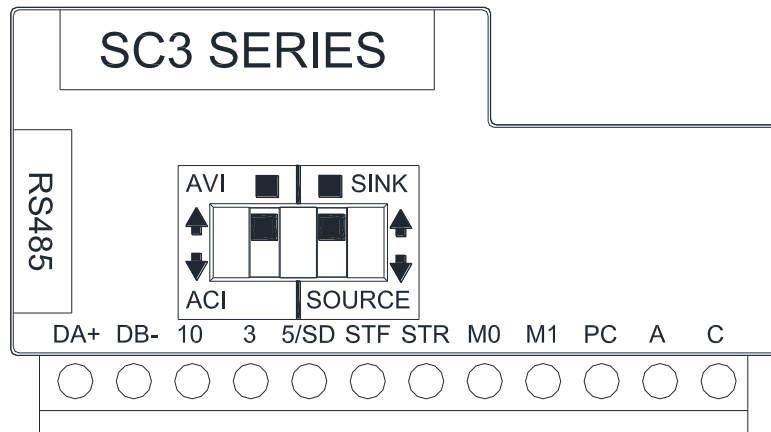

Note: 1. Please Use a small flathead screwdriver (tip thickness: 0.6mm, width: 3.0mm). If a flathead screwdriver with a narrow tip is used, terminal block maybe damaged.

2. Tightening torque is 3.2~4.8kgf.cm, too large tightening torque can cause screw slippage; too little tightening torque can cause a short circuit or malfunction.

✓ Toggle switch



| Switch number | Switch state  | Explanation                                   | Remarks |
|---------------|---|---|---------|
| SINK/SOURCE   |  * | Switch the input models "STF、STR、M0、M1"       |         |
|               |    |   |         |
| AVI/ACI       |  * | Input 0~10V voltage signal into terminal 3-5  |         |
|               |    | Input 4~20mA current signal into terminal 3-5 |         |

Note: 1. The state with "\*" is the default state of switch.  
 2. The parts in black stand for switch handle.

## 3.8 Replacement procedure of fan

### 3.8.1 Frame A/B

1. Press the hooks on both side of the fan to remove the fan. (As shown below.)

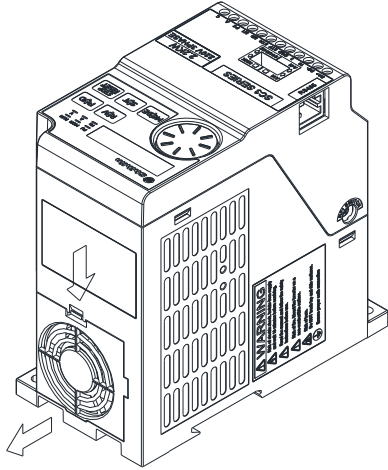

2. Disconnect the power terminal, and then remove the fan. (As shown below.)

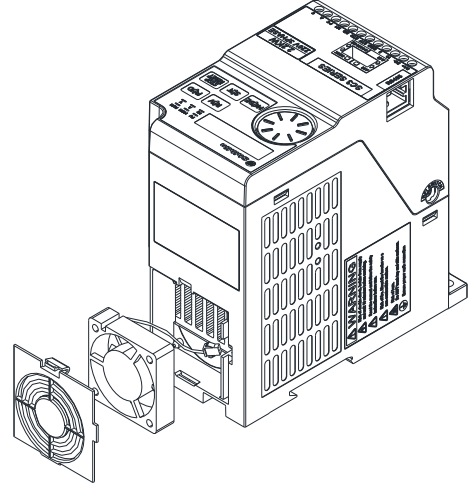

## 4. PRIMARY OPERATION

### 4.1 Component name of operation panel

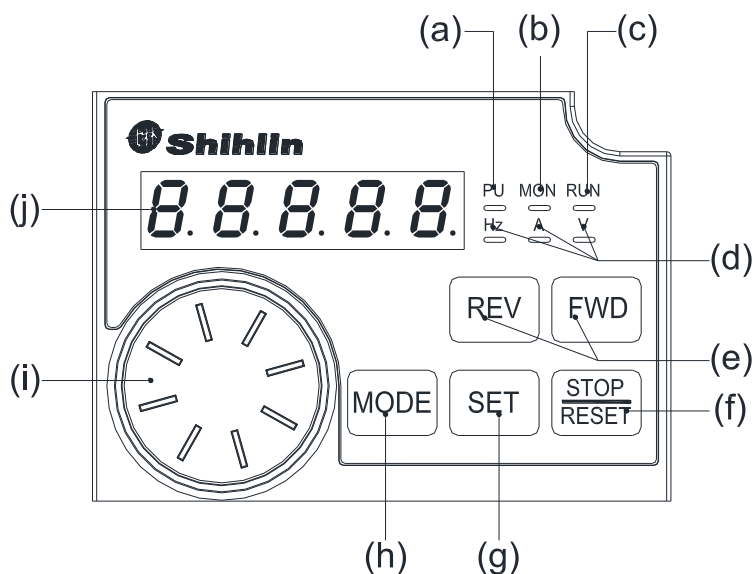

| NO. | Operation parts | Name                             | Content   |
|-----|-----------------|----------------------------------|---|
| (a) | PU<br>—         | Operation mode indicator         | PU: ON to indicate the PU operation mode, flickers in the H1~H5 operation mode.   |
| (b) | MON<br>—        | Operation panel status indicator | MON: ON to indicate the monitoring mode.  |
| (c) | RUN<br>—        | Run status indicator             | The light is on when running.   |
| (d) | Hz A V<br>— — — | Unit indicator                   | Hz: ON to indicate the frequency.<br>A: ON to indicate the output current.<br>V: ON to indicate the selected monitoring item mentioned by 00-07 (P.161), which default monitoring item is output voltage. |
| (e) | REV FWD         | FWDbutton REVbutton              | FWD: Starts forward rotation. The LED is on during forward operation.<br>REV: Starts reverse rotation. The LED is on during reverse operation.  |
| (f) | STOP<br>RESET   | STOP/RESETbutton                 | Stops the operation commands.<br>Resets the inverter for alarm.   |
| (g) | SET             | Set button                       | Click the button for a long time, write into the parameter value and frequency etc.<br>Click the button for a short time, read the parameter value and will enter the next menu.                          |
| (h) | MODE            | MODEbutton                       | Switches to different modes.  |
| (i) |                 | MSetting dial                    | The function of clockwise rotation equals to UP button.<br>The function of anticlockwise rotation equals to DOWN button.  |
| (j) | 8.8.8.8.8.      | Monitor (5-digit LED)            | Shows the frequency, parameter number, and parameter value, etc.  |

## 4.2 Operation modes of the inverter

- The operation modes are related to the reference source of the target frequency and the signal source of the motor starting. The Shihlin SC3 inverter has a total of ten kinds of operation modes, namely, "PU mode  $PU$ ", "JOG mode  $JOG$ ", "external mode  $OPnd$ ", "communication mode  $CU$ ", "combined mode  $1H1$ ", "combined mode  $2H2$ ", "combined mode  $3H3$ ", "combined mode  $4H4$ " and "combined mode  $5H5$ " and the second operation mode.
- You can use operation panel to monitor the output frequency, the output voltage and the output current, as well as to view the alarm message, the parameter setting and the frequency setting. The operator has four work modes, namely, "operation mode", "monitoring mode", "frequency setting mode" and "parameter setting mode".

| Related parameters                      | Values                | Operation mode   | The reference source of target frequency   | The signal source of motor starting  | Remarks  |
|---|-----------------------|--|--|--|--|
| Operation mode selection<br>00-16(P.79) | 0                     | PU mode ( $PU$ )   | PU operation panel   | <input type="button" value="FWD"/> or <input type="button" value="REV"/> button for PU operation panel | The "PU mode", "JOG mode" and "external mode" are interchangeable. |
|   |                       | JOG mode ( $JOG$ )   | The setting value of 01-13(P.15)   | <input type="button" value="FWD"/> or <input type="button" value="REV"/> button for PU operation panel |  |
|   |                       | External mode ( $OPnd$ )   | "External voltage/current signal", "combination of multi-speed stage levels" and external JOG(01-13(P.15))<br>Frequency of each section in the programmed operation mode 04-19~ 04-26 /P.131~P.138 | External forward and reverse terminals<br><br>External STF terminal                                    |  |
|   | 1                     | PU mode ( $PU$ )   | Equal to the "PU mode" when 00-16(P.79) = 0  |  | The "PU mode" and "JOG mode" are interchangeable.                  |
|   |                       | JOG mode ( $JOG$ )   | Equal to the "PU mode" when 00-16(P.79) = 0  |  |  |
|   | 2                     | External mode ( $OPnd$ )   | Equal to the "External mode" when 00-16(P.79) = 0  |  |  |
|   | 3                     | Communication mode ( $CU$ )  | Communication  | Communication  |  |
|   | 4                     | Combined mode $1(H1)$  | PU operation panel   | External forward and reverse terminals   |  |
|   | 5                     | Combined mode $2(H2)$  | "External voltage / current signal", "combination of multi-speed stage levels"   | <input type="button" value="FWD"/> or <input type="button" value="REV"/> button for PU operation panel |  |
|   | 6                     | Combined mode $3(H3)$  | Communication, "combination of multi-speed stage levels" and External JOG(01-13(P.15))   | External forward and reverse terminals   |  |
| 7                                       | Combined mode $4(H4)$ | "External voltage / current signal", "combination of multi-speed stage levels"               | Communication  |  |  |
| 8                                       | Combined mode $5(H5)$ | PU operation panel, "combination of multi-speed stage levels" and External JOG (01-13(P.15)) | External forward and reverse terminals   |  |  |

- ◆ When 00-16(P.79) = 0, the external mode ( $OPnd$ ) is the default mode after the inverter is turned on. Use 00-16(P.79) to switch the operation mode.

### 4.2.1 The flow chart for switching the operation mode

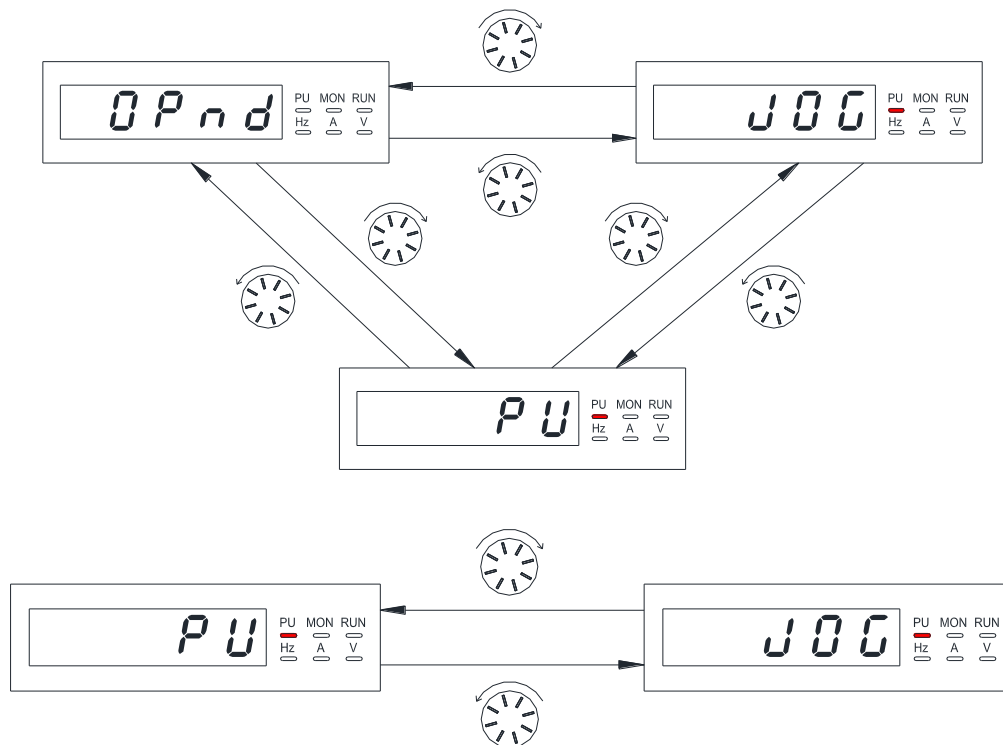

- Note: 1. In "PU mode", operation panel screen displays *PU*, and the indicating lamp **PU** will light up.  
 2. In "external mode," operation panel screen displays *OPnd*  
 3. In "combined mode 1, 2, 3, 4, or 5", the indicating lamp **PU** will glitter on the operation panel screen.  
 4. In "JOG mode", the indicating lamp **PU** will light up, and the screen shows *JOG* when the motor isn't running.  
 5. No flow chart when 00-16(P.79)=2, 3, 4, 5, 6, 7 or 8 because the operation mode will be constant.

### 4.2.2 The flow chart for switching the working mode

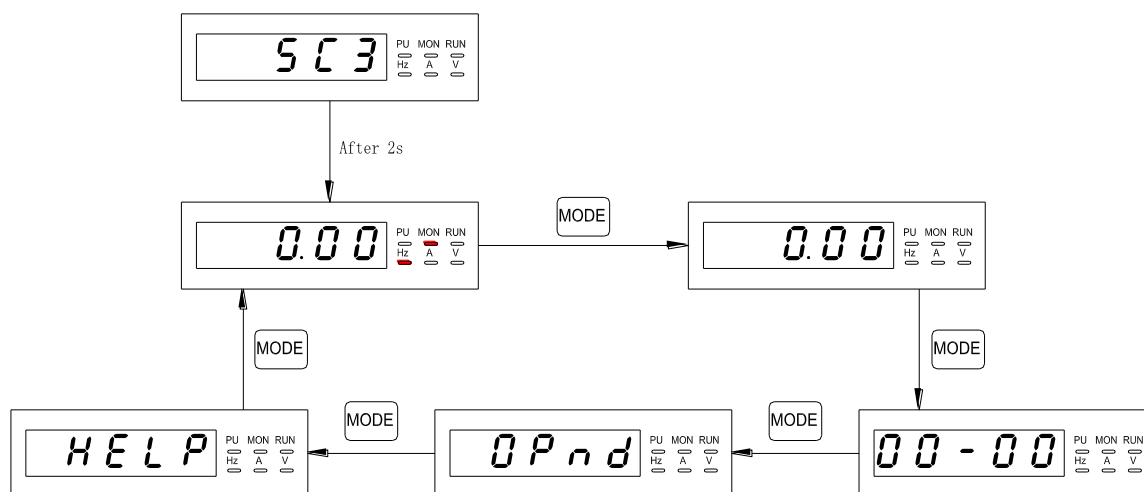

- Note: 1. Please refer to section 4.2.3 for the detailed operation flow under the monitoring mode.  
 2. Please refer to section 4.2.4 for the detailed operation flow under the frequency setting mode.  
 3. Please refer to section 4.2.5 for the detailed operation flow under the parameter setting mode.  
 4. Please refer to Section 4.2.1 for detailed operation flow under the switching operation mode.  
 5. Please refer to Section 4.2.6 for the HELP mode of operation process in detail.

### 4.2.3 The operation flow charts for monitoring mode

•Take PU mode for example:

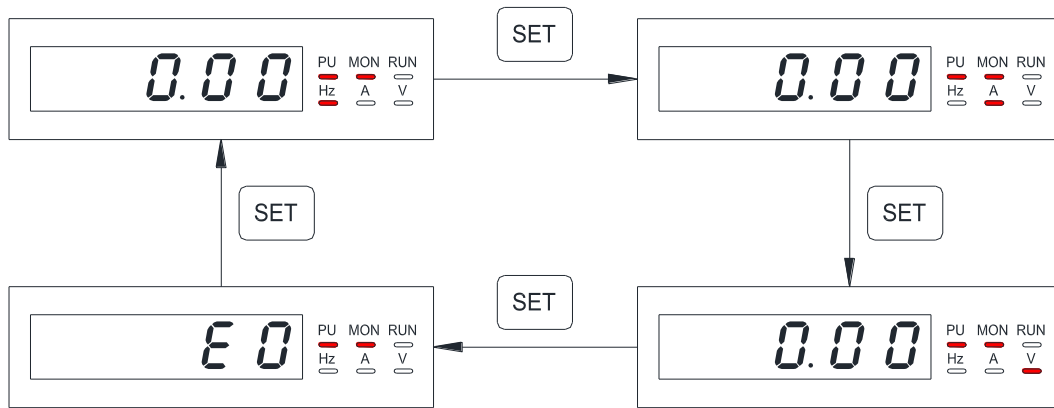

- Note: 1. In the “monitoring output frequency mode”, indicating lamp **MON** and **Hz** will light up, and the screen will display the current output frequency.
2. In the “monitoring output voltage mode”, indicating lamp **MON** and **V** will light up, and the screen will display the current output voltage.
3. In the “monitoring output current mode”, indicating lamp **MON** and **A** will light up, and the screen will display the current output current.
4. When in the “browsing alarm record mode,” indicating lamp **MON** will light up, and the screen will display the current alarm code.
5. For alarm codes, please refer to Appendix 2.

### 4.2.4 Operation flow charts for frequency setting mode

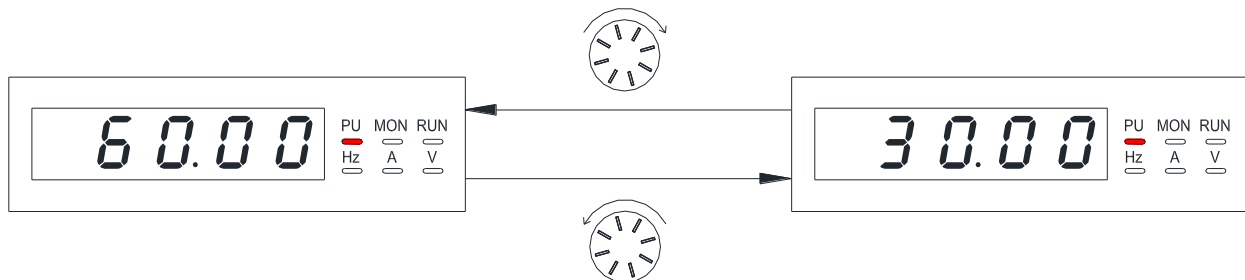

- Note: 1. Use  to change the frequency when the inverter is running.
2. Indicating lamp **Hz** will light up, but not **MON** under the frequency setting mode.
3. When setting the frequency under the PU mode, the set value cannot exceed the upper frequency. When high frequency is needed, the upper frequency should be changed first.

### 4.2.5 Operation flow charts for parameter setting mode

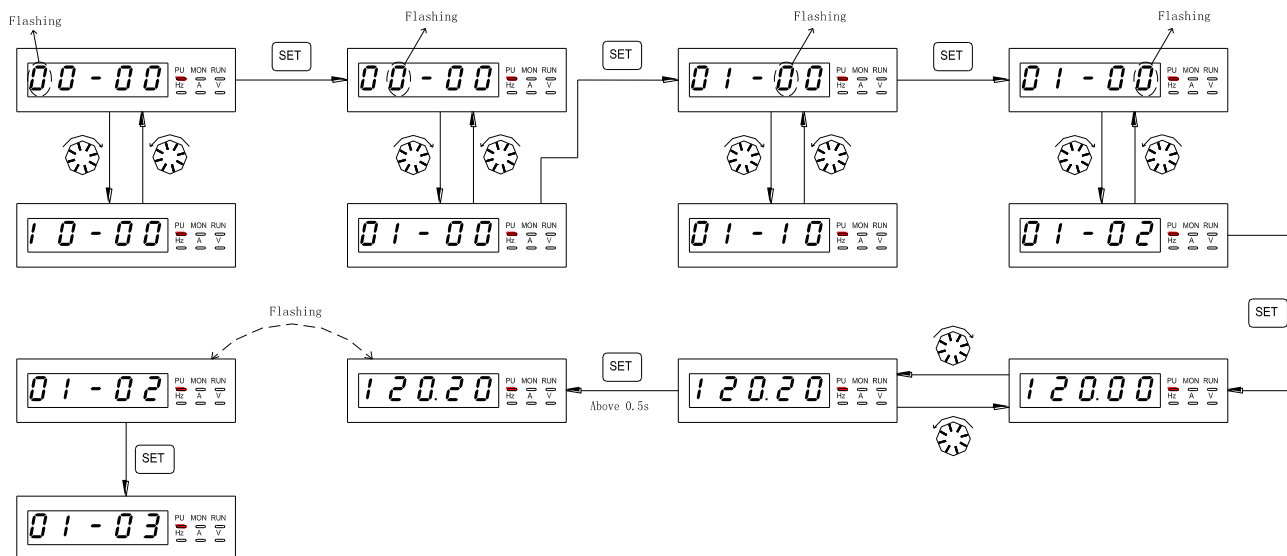

Note: Neither Indicating lamp **Hz** nor **MON** will light up under the parameter setting mode. Please Use **SET** to write the parameter.

### 4.2.6 Operation flow charts of HELP model, using SC3-TYPE operation panel

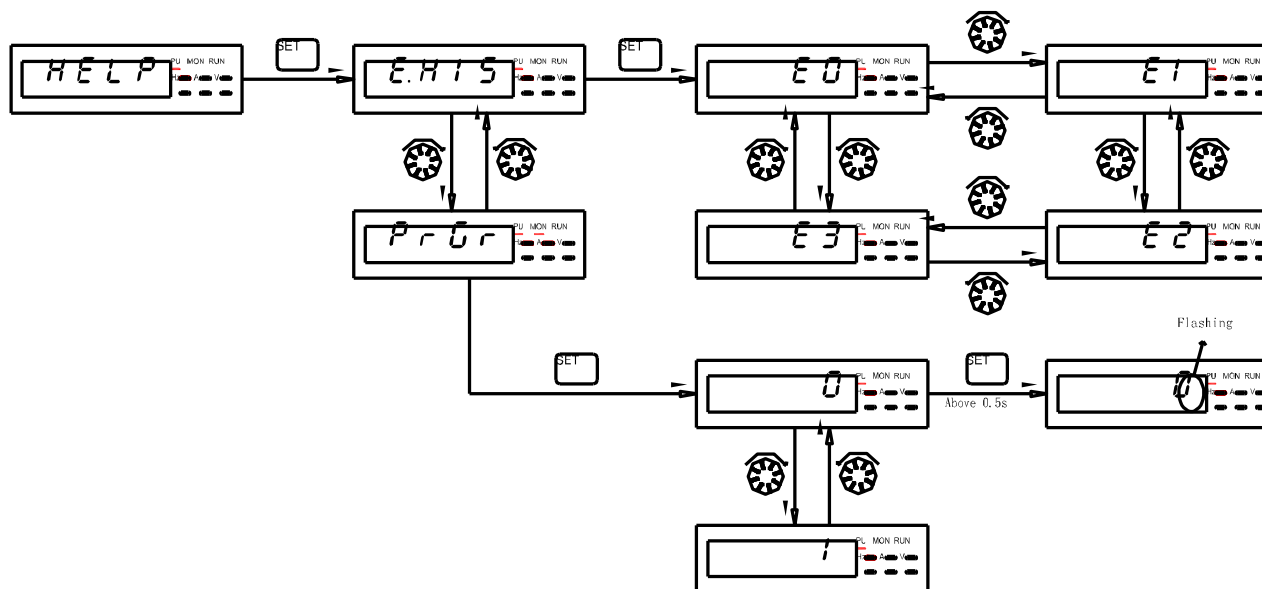



Note: 1. Browsing the alarm record, display screen shows the recent four groups of alarm codes.



2. Different code, please refer to appendix 2.

## 4.3 Basic operation procedures for different modes





### 4.3.1 Basic operation procedures for PU mode (00-16(P.79) = 0 or 1)

| Step | Description  |
|------|--|
| 1    | <ul style="list-style-type: none"> <li>Change the operation mode to PU mode, and indicating lamp <b>PU</b>  will light up.</li> </ul> <p>Note: 1. When 00-16(P.79) =0, the inverter will first go into the external mode after the power is switched on or the inverter is reset.</p> <p>2. For selecting and switching the operation mode, please refer to Section 4.2.</p>  |
| 2    | <ul style="list-style-type: none"> <li>Enter into the frequency setting mode and write the target frequency into memory.</li> </ul> <p>Note: For detailed setting procedures, please refer to Section 4.2.4.</p>   |
| 3    | <ul style="list-style-type: none"> <li>Press <b>FWD</b> or <b>REV</b> to run the motor. At this point, indicating lamp <b>RUN</b>  will light up, indicating that the motor is running. The PU301 operation panel will automatically go into the monitor mode and display the current stable output frequency.</li> </ul> <p>Note: 1. For detailed operation flow for the monitoring mode, please refer to Section 4.2.3.</p> <p>2. While the motor is running, the user can enter into the frequency setting mode to change the target frequency for regulating the motor speed.</p> |
| 4    | <ul style="list-style-type: none"> <li>Press <b>STOP/RESET</b> and the motor will begin to decelerate until it comes to a full stop.</li> <li>Indicating lamp <b>RUN</b>  will not turn off until the inverter stops the output voltage.</li> </ul>   |

### 4.3.2 Basic operation procedures for external mode (00-16(P.79) = 0 or 2)

| Step | Description  |
|------|--|
| 1    | <ul style="list-style-type: none"> <li>Change the operation mode to external mode, the screen will display <i>Opnd</i>.</li> </ul> <p>Note: 1. When 00-16(P.79) =0, after the power is switched on or the inverter is reset, press <b>MODE</b> to switch to operation mode, the inverter will first go into the external mode, and then use  to switch to PU mode.</p> <p>2. When 00-16(P.79) =2, external mode will be the default for the inverter.</p> <p>3. For selecting and switching the operation mode, please refer to Section 4.2.</p>   |
| 2    | <ul style="list-style-type: none"> <li>The target frequency is set by external terminals (the default priority is from high to low):</li> <li>If the programmable operating mode is chosen, please refer to Section 5.4.1 Function selection of digital input and 5.5.2 Programmed operation mode.</li> <li>If the target frequency is set by multi-speed stage levels, please refer to 04-00(P.4) in Chapter 5.</li> <li>If the target frequency is set by the input signal across terminal 3-5, please refer to 02-21(P.39) in Chapter 5.</li> </ul>   |
| 3    | <ul style="list-style-type: none"> <li>Turn on STF or STR to run the motor.</li> <li>At this point, indicating lamp <b>RUN</b>  will light up, indicating that the motor is running.</li> </ul> <p>Note: 1. For setting up the starting terminals STF and STR, please refer to 00-15(P.78) in Chapter 5.1.8 and 5.4.1 Function selection of digital input.</p> <p>2. For detailed operation flow for the monitor mode, please refer to Section 4.2.3.</p> <p>3. If programmed operation mode is chosen, then STF and STR will become the starting signal and the pause signal, respectively, instead of being the Run Forward or Run Reverse terminals.</p> |
| 4    | <ul style="list-style-type: none"> <li>Turn off STF or STR to decelerate the motor until it comes to a full stop.</li> <li>Indicating lamp <b>RUN</b>  will not turn off until the inverter stops the output voltage.</li> </ul>  |



### 4.3.3 Basic operation procedures for JOG mode (00-16(P.79) = 0 or 1)

| Step | Description   |
|------|---|
| 1    | <ul style="list-style-type: none"> <li>Change the operation mode to the JOG mode and indicating lamp <b>PU</b>  will light up. At this point, the screen will display .</li> </ul> <p>Note: For selecting and switching the operation mode, please refer to Section 4.2.</p>   |
| 2    | <ul style="list-style-type: none"> <li>Press <b>REV</b> or <b>FWD</b> to run the motor. At this point, indicating lamp <b>RUN</b>  will light up, indicating that the motor is running.</li> <li>Release <b>FWD</b> or <b>REV</b> to decelerate the motor until it comes to a full stop. Indicating lamp <b>RUN</b>  will not turn off until the inverter stops the output.</li> </ul> <p>Note: 1. For detailed operation flow for the monitor mode, please refer to Section 4.2.3.<br/>2. In the JOG mode, the target frequency is the value of 01-13(P.15), and the acceleration / deceleration time is the value of 01-14(P.16). Please refer to 01-13(P.15) in Chapter 5.</p> |







### 4.3.4 Basic operation procedures for communication mode (00-16(P.79) = 3)

- ◆ In the communication mode, the user can set the parameters and run/stop or reset the inverters by communication. Please refer to communication function related parameters for details.



### 4.3.5 Basic operation procedures for combined mode 1 (00-16(P.79) = 4)

| Step | Description   |
|------|---|
| 1    | <ul style="list-style-type: none"> <li>In Combined Mode 1, indicating lamp <b>PU</b>  will light up.</li> </ul> <p>Note: For selecting and switching the operation mode, please refer to Section 4.2.</p>  |
| 2    | <ul style="list-style-type: none"> <li>Enter into the frequency setting mode and write the target frequency into memory.</li> </ul> <p>Note: For detailed frequency setting procedures, please refer to Section 4.2.4.</p>  |
| 3    | <ul style="list-style-type: none"> <li>Set the target frequency via operation panel and start the inverter by the digital input terminals.</li> <li>At this point, indicating lamp <b>RUN</b>  will light up, indicating that the motor is running.</li> </ul> <p>Note: For detailed operation flow for the monitor mode, please refer to Section 4.2.3.</p> |
| 4    | <ul style="list-style-type: none"> <li>When the digital input terminals stop the output signals, the motor will decelerate until it comes to a full stop.</li> <li>Indicating lamp <b>RUN</b>  will not turn off until the inverter stops the output.</li> </ul>   |



## 4.3.6 Basic operation procedures for combined mode 2 (00-16(P.79) = 5)

| Step | Description   |
|------|---|
| 1    | <ul style="list-style-type: none"> <li>In Combined Mode 2, indicating lamp <b>PU</b>  will light up.</li> </ul> <p>Note: For selecting and switching the operation mode, please refer to Section <a href="#">4.2</a>.</p>  |
| 2    | <ul style="list-style-type: none"> <li>The target frequency is set by the external terminals (the default priority is from high to low):</li> <li>If the programmable operating mode is chosen, please refer to Section <a href="#">5.4.1</a> Function selection of digital input and <a href="#">5.5.2</a> Programmed operation mode.</li> <li>If the target frequency is set by multi-speed stage levels, please refer to <a href="#">04-00(P.4)</a> in Chapter 5..</li> <li>If the target frequency is set by the input signal across terminal 3-5, please refer to <a href="#">02-21(P.39)</a> in Chapter 5.</li> </ul>   |
| 3    | <ul style="list-style-type: none"> <li>Press  or  of operation panel to run the motor. At this point, indicating lamp <b>RUN</b>  will light up, indicating that the motor is running.</li> </ul> <p>Note: 1. For detailed operation flow for the monitor mode, please refer to Section <a href="#">4.2.3</a>.</p> <p>2. While the motor is running, the user can enter into the frequency setting mode to change the target frequency for regulating the motor speed.</p> |
| 4    | <ul style="list-style-type: none"> <li>Press  and the motor will begin to decelerate until it comes to a full stop.</li> <li>Indicating lamp <b>RUN</b>  will not turn off until the inverter stops the output.</li> </ul>  |



#### 4.3.7 Basic operation procedures for combined mode 3 (00-16(P.79) = 6)

| Step | Description  |
|------|--|
| 1    | <ul style="list-style-type: none"> <li>In Combined Mode 3, indicating lamp <b>PU</b>  will light up.</li> </ul> <p>Note: For selecting and switching the operation mode, please refer to Section 4.2.</p>   |
| 2    | <ul style="list-style-type: none"> <li>The target frequency is determined by communication:</li> <li>When RL, RM, RH and REX of multi-speed stage levels are “on”, the target frequency is determined by combination of multi-speed stage levels (Please refer to 04-00~04-02/P.4~P.6, 03-00~03-01/P.83~P.84 , 03-03~03-04/P.80~P.81. )</li> <li>When external JOG is “on”, the target frequency is determined by 01-13(P.15). Acceleration / deceleration time is set by the value of 01-14(P.16).</li> </ul> |
| 3    | <ul style="list-style-type: none"> <li>The inverter starting is activated by the external terminals. At this point, indicating lamp <b>RUN</b>  will light up, indicating that the motor is running.</li> <li>The functions of 00-02(P.996、 P.998、 P.999) can be accomplished by communication.</li> </ul> <p>Note: For detailed operation flow for the monitor mode, please refer to Section 4.2.3.</p>                    |
| 4    | <ul style="list-style-type: none"> <li>When the digital input terminals stop the output signals, the motor will decelerate until it comes to a full stop.</li> <li>Indicating lamp <b>RUN</b>  will not turn off until the inverter stops the output.</li> </ul>  |

#### 4.3.8 Basic operation procedures for combined mode 4 (00-16(P.79) = 7)

| Step | Description   |
|------|---|
| 1    | <ul style="list-style-type: none"> <li>In Combined Mode 4, indicating lamp <b>PU</b>  will light up.</li> </ul> <p>Note: For selecting and switching the operation mode, please refer to Section 4.2.</p>  |
| 2    | <ul style="list-style-type: none"> <li>The target frequency of the inverter is determined by the external terminals’ “external voltage signal”, “external current signal”, or “combination of multi-speed stage levels”.</li> </ul>   |
| 3    | <ul style="list-style-type: none"> <li>The inverter starting is activated by communication (including “Reset”). At this point, indicating lamp <b>RUN</b>  will light up, indicating that the motor is running.</li> </ul> <p>Note: 1. For detailed operation flow for the monitor mode, please refer to Section 4.2.3.<br/>2. While the motor is running, the user can enter into the frequency setting mode to change the target frequency for regulating the motor speed.</p> |
| 4    | <ul style="list-style-type: none"> <li>When communication sends the stop instruction, the motor will decelerate until it comes to a full stop.</li> <li>Indicating lamp <b>RUN</b>  will not turn off until the inverter stops the output.</li> </ul>  |

## 4.3.9 Basic operation procedures for combined mode 5 (00-16(P.79) = 8)



| Step | Description  |
|------|--|
| 1    | <ul style="list-style-type: none"> <li>In Combined Mode 5, indicating lamp <b>PU</b>  will light up.</li> </ul> <p>Note: For selecting and switching the operation mode, please refer to Section 4.2.</p>   |
| 2    | <ul style="list-style-type: none"> <li>The target frequency of the inverter is set by operation panel:</li> <li>When RL, RM, RH and REX of multi-speed stage levels are “on”, the target frequency is determined by combination of multi-speed stage levels (please refer to 04-00~04-02/P.4~P.6, 03-00~03-01/P.83~P.84 , 03-03~03-04/P.80~P.81)。</li> <li>When external JOG is “on”, the target frequency is determined by 01-13(P.15). Acceleration / deceleration time is set by the value of 01-14(P.16).</li> </ul> |
| 3    | <ul style="list-style-type: none"> <li>The inverter starting is activated by the external forward and reverse terminals.</li> </ul> <p>Note: 1. For detailed operation flow for the monitor mode, please refer to Section 4.2.3.<br/>2. While the motor is running, the user can enter into the frequency setting mode to change the target frequency for regulating the motor speed.</p>  |
| 4    | <ul style="list-style-type: none"> <li>When the digital input terminals stop the output signals, the motor will decelerate until it comes to a full stop.</li> <li>Indicating lamp <b>RUN</b>  will not turn off until the inverter stops the output.</li> </ul>  |

## 4.4 Operation

### 4.4.1 Pre-operation checks and preparation

Before starting the operation, the following shall be examined:

1. Check if the wiring is correct. Check especially the ac motor driver output terminals (U/T1, V/T2, W/T3), which cannot be connected to the power. Confirm that grounding terminal () is well grounded.
2. Check if there is a short circuit at the terminals or charged exposure.
3. Verify all terminal connections, and check if plug connectors (optional) and screws are all fastened.
4. Verify that no mechanical device is connected to the motor.
5. All switches must be disconnected before power on. Make sure that the inverter will not start and there is no abnormal activity when power on.
6. Turn on the power only after the cover is well placed.
7. Do not operate the switch with a wet hand.
8. Make sure of the following after power on:





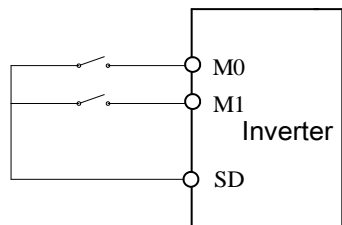
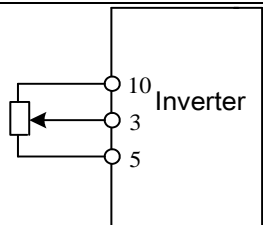

The operating screens should display normally, both indicating lamp  Hz and **MON**  will light up.

### 4.4.2 Operation methods

For various operation methods, please refer to basic operation procedures in Chapter 4 and parameter description in Chapter 5. Select the most appropriate operation methods according to the application requirements and regulations. The most commonly used operation methods are shown below:

| Operation method                   | Source of the target frequency  | Source of the operating signal   |
|------------------------------------|---|--|
| operation panel operation          |    | <input type="button" value="FWD"/> or <input type="button" value="REV"/> |
| External terminal signal operation |  <p style="margin-left: 150px;">Parameter setting:<br/>04-01(P.5)=30<br/>04-02(P.6)=10</p> | Input by digital input terminal:<br>STF-SD<br>STR-SD                     |
|                                    |  <p style="text-align: center;">3-5 terminal input</p>                                     |  |

### 4.4.3 Trial run

- ◆ Check cables and abnormalities before the trial run. After power on, the inverter is in the external mode.
  1. After power on, make sure the operating screen is normal, the indicating lamp power  Hz and  MON is on.
  2. Connect a switch between STF and SD or STR and SD.
  3. Connect a potentiometer between 3-5-10 or provide 0~5V dc between 3 and 5.
  4. Adjust potentiometer or 0~5V dc to a minimum value (under 1V).
  5. If STF is on, forward rotation is activated. If STR is on, reverse rotation is activated. Turn off STF or STR to decelerate the motor until it stops completely.
  6. Check the following:
    - 1). whether the direction of motor rotation is correct.
    - 2). whether the rotation is smooth (check for any abnormal noise and vibration).
    - 3). whether the acceleration / deceleration is smooth.
  
- ◆ If there is an optional keyboard panel, do the following:
  1. Make sure that the keyboard panel is connected to the inverter properly.
  2. Change the operation mode to PU mode after power on, and the screen will display 50/60Hz.
  3. Press  button to set the target frequency at about 5Hz.
  4. Press  for forward rotation and  for reverse rotation. Press  to decelerate the motor until it stops completely.
  5. Check the following:
    - 1) Whether the direction of motor rotation is correct.
    - 2) Whether the rotation is smooth (check for any abnormal noise and vibration).
    - 3) Whether the acceleration / deceleration is smooth.
  
- ◆ If no abnormal condition is found, continue the trial run by increasing the frequency and go through the above procedure. Put the machine into operation if no abnormal condition is found.

Note: Stop working immediately if abnormalities are found when running the inverter or the motor. Check for possible causes according to "fault diagnosis". After inverter output is stopped and the power terminals (R/L1, S/L2, and T/L3) of the main circuit are disconnected, electric shock may occur if one touches the inverter's output terminals (U/T1, V/T2, and W/T3). Even if the major loop power is cut off, there is still recharging voltage in the filter capacitors. As a result, discharge takes time. Once the major loop power is disconnected, wait for the power indicating lamp to go off before testing the intermediate dc loop with a dc voltage meter. Once the voltage is confirmed to be below the safe value, it is safe to touch the circuit inside the inverter.

## 5. PARAMETER DESCRIPTION

### 5.1 System parameter group00

| Group | Parameter Number | Name                                     | Setting Range   | Factory Value | Page |
|-------|------------------|--|---|---------------|------|
| 00-00 | P.90             | The inverter model                       | Read  | ---           | 47   |
| 00-01 | P.188            | Firmware version                         | Read  | ---           | 47   |
| 00-02 | P.996 ~<br>P.999 | Parameter restoration                    | 0: Non-function   | 0             | 48   |
|       |                  |  | 1: Alarm history clear (P.996=1)  |               |      |
|       |                  |  | 2: Inverter reset (P.997=1)   |               |      |
|       |                  |  | 3: Restoring all parameters to default values (P.998=1)   |               |      |
|       |                  |  | 4: Restoring some parameters to default values1 (P.999=1)   |               |      |
|       |                  |  | 5: Restoring some parameters to default values 2 (P.999=2)  |               |      |
| 00-03 | P.77             | Selection of Parameters write protection | 0: Parameters can be written only when the motor stops.   | 0             | 50   |
|       |                  |  | 1: Parameters cannot be written.  |               |      |
|       |                  |  | 2: Parameters can also be written when the motor is running.  |               |      |
|       |                  |  | 3: Parameters cannot be written when in password protection.  |               |      |
| 00-04 | P.294            | Decryption parameter                     | 0~65535   | 0             | 50   |
| 00-05 | P.295            | Password setup                           | 2~65535   | 0             | 50   |
| 00-06 | P.110            | Parameter unit monitoring selection      | 0: When the inverter starts, the operation panel enters the monitoring mode automatically, and the screen displays the output frequency.(this frequency for slip compensation)                | 2             | 52   |
|       |                  |  | 1: When the inverter starts, the screen of the operation panel displays the target frequency.   |               |      |
|       |                  |  | 2: When the inverter starts, the operation panel enters the monitoring mode automatically, and the screen displays current output frequency.  |               |      |
|       |                  |  | 3: When the inverter starts, the operation panel enters the monitoring mode automatically, and the screen displays the current pressure and feedback pressure of the constant pressure system |               |      |
|       |                  |  | 4: When the inverter starts, the operation panel doesn't enter the monitoring mode automatically, and the screen displays the mode of starting.   |               |      |

| Group                                | Parameter Number | Name   | Setting Range  | Factory Value | Page |
|--------------------------------------|------------------|--|--|---------------|------|
| 00-07                                | P.161            | Multi-function display   | 0: Output voltage (V)  | 0             | 52   |
|                                      |                  |  | 1: DC bus voltage (V)  |               |      |
|                                      |                  |  | 2: Temperature rising accumulation rate of inverter (%)  |               |      |
|                                      |                  |  | 3: Target pressure of the constant pressure system (%)   |               |      |
|                                      |                  |  | 4: Feedback pressure of the constant pressure system (%)   |               |      |
|                                      |                  |  | 5: Operation frequency (Hz)  |               |      |
|                                      |                  |  | 6: Electronic thermal accumulation rate (%)  |               |      |
|                                      |                  |  | 7: Reserved.   |               |      |
|                                      |                  |  | 8: Signal value (mA) of 3-5 simulating input terminals (mA/V).   |               |      |
|                                      |                  |  | 9: Output power (kW).  |               |      |
|                                      |                  |  | 10: Reserved.  |               |      |
|                                      |                  |  | 11: Positive and reverse rotation signal. Then 1 represents positive rotation, 2 represents reverse rotation, and 0 represents stopping state. |               |      |
|                                      |                  |  | 12: NTC temperature (°C)   |               |      |
|                                      |                  |  | 13: Electronic thermal accumulation rate of motor (%)  |               |      |
|                                      |                  |  | 14~18: Reserved.   |               |      |
| 19: Digital terminal input state     |                  |  |  |               |      |
| 20: Digital terminal output state    |                  |  |  |               |      |
| 21: Actual working carrier frequency |                  |  |  |               |      |
| 00-08                                | P.37             | Speed display  | 0: Display output frequency(the mechanical speed is not displayed)   | 0             | 53   |
|                                      |                  |  | 0.1~5000.0   |               |      |
|                                      |                  |  | 1~9999   |               |      |
| 00-09                                | P.259            | Speed unit selection   | 0: Speed display selection unit is 1   | 1             | 53   |
|                                      |                  |  | 1: Speed display selection unit is 0.1   |               |      |
| 00-10                                | P.59             | The setting frequency selection of rotary knob on the operating keyboard | XXX0:The frequency set by frequency inverter itself shuttle knob is effective  | 0             | 54   |
|                                      |                  |  | XXX1: Thefrequencyset by the knob of the manipulator is effective.   |               |      |
|                                      |                  |  | X0XX: After changing the frequency, automatic storage after 30s.   |               |      |
|                                      |                  |  | X1XX: After changing the frequency, automatic storage after 10s.   |               |      |
|                                      |                  |  | X2XX :After changing the frequency, don'tstore automatically   |               |      |
|                                      |                  |  | 0XXX: After to shuttle set frequency, the frequency of changes take effect immediately   |               |      |
|                                      |                  |  | 1XXX: After to shuttle set frequency and the set key run, the frequency of change take effect.   |               |      |

System parameter group00

| Group                | Parameter Number | Name  | Setting Range   | Factory Value | Page |
|----------------------|------------------|---|---|---------------|------|
| 00-11                | P.72             | Carrier frequency                             | 1~15  | 5 kHz         | 54   |
| 00-12                | P.31             | Soft-PWM carrier operation selection          | 0: None Soft-PWM operation  | 0             | 54   |
|                      |                  |   | 1: When 00-11(P.72)< 5, Soft-PWM is valid (only apply to V/F control )  |               |      |
|                      |                  |   | 2: When P.72>9, Inverter module's temperature is exorbitant, carrier will automatically lower, after module's temperature dropping, carrier will automatically return to P. 72 set value. |               |      |
| 00-13                | P.71             | Idling braking / DC braking                   | 0: Idling braking   | 1             | 55   |
|                      |                  |   | 1: DC braking   |               |      |
| 00-14                | P.75             | Stop function selection                       | 0: Press STOP button and stop the operation only in the PU and H2 mode  | 1             | 55   |
|                      |                  |   | 1: Press STOP button and stop the operation in all mode.  |               |      |
| 00-15                | P.78             | Forward/reverse rotation prevention selection | 0: Forward rotation and reverse rotation are both permitted.  | 0             | 56   |
|                      |                  |   | 1: Reverse rotation is prohibited (Press the reverse reference to decelerate and stop the motor).   |               |      |
|                      |                  |   | 2: Forward rotation is prohibited (Press the forward rotation reference to decelerate and stop the motor).  |               |      |
| 00-16                | P.79             | Operation mode selection                      | 0: "PU mode", "external mode" and "Jog mode" are interchangeable.   | 0             | 57   |
|                      |                  |   | 1: "PU mode" and "JOG mode" are interchangeable.  |               |      |
|                      |                  |   | 2: "External mode" only   |               |      |
|                      |                  |   | 3: "Communication mode" only  |               |      |
|                      |                  |   | 4: "Combined mode 1"  |               |      |
|                      |                  |   | 5: "Combined mode 2"  |               |      |
|                      |                  |   | 6: "Combined mode 3"  |               |      |
|                      |                  |   | 7: "Combined mode 4"  |               |      |
| 8: "Combined mode 5" |                  |   |   |               |      |
| 00-17                | P.97             | The second target frequency selection         | 0: Frequency set by operation panel   | 0             | 57   |
|                      |                  |   | 1: Frequency set by Communication RS485   |               |      |
|                      |                  |   | 2: Frequency set by the analog  |               |      |
| 00-19                | P.35             | Communication mode instruction selection      | 0: In communication mode, operating instruction and setting frequency is set by communication.  | 0             | 57   |
|                      |                  |   | 1: In communication mode, operating instruction and setting frequency is set by external.   |               |      |
| 00-21                | P.300            | Motor control mode selection                  | 0: Induction motor V/F control  | 0             | 57   |
|                      |                  |   | 1: Reserved   |               |      |
|                      |                  |   | 2: Induction motor general magnetic vector control  |               |      |
| 00-24                | P.189            | 50Hz/60Hz switch selection                    | 0: The frequency parameter default value is 60Hz system.  | 0             | 58   |
|                      |                  |   | 1: The frequency parameter default value is 50Hz system.  | 1             |      |
| 00-25                | P.990            | Parameter mode setting                        | 0: Parameter is displayed as "group mode"   | 0             | 59   |
|                      |                  |   | 1: Parameter is displayed as "conventional P mode"  |               |      |

## 5.1.1 Inverter information

- ◆ Inquire the inverter model, control board firmware version, and the connected expansion card, etc.

| Parameter      | Name               | Factory Value | Setting Range | Content                                     |
|----------------|--------------------|---------------|---------------|---|
| 00-00<br>P.90  | The inverter model | --            | Read          | ---   |
| 00-01<br>P.188 | Firmware version   | --            | Read          | The inverter control board firmware version |

- ◆ The inverter model

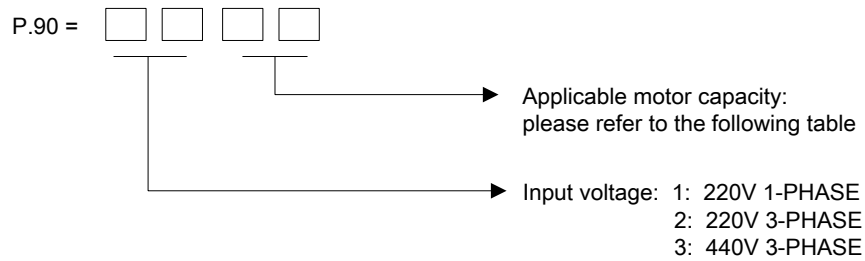

**Read** The applicable motor capacity:

| Value(value of the two low-order bits of 00-00) | Capacity (kw) |
|---|---------------|
| 2   | 0.4           |
| 3   | 0.75          |
| 4   | 1.5           |
| 5   | 2.2           |
| 6   | 3.7           |
| 7   | 5.5           |

Note: The parameters above are for reading only, not for writing.

## 5.1.2 Parameter restoration

- ◆ Restore the parameters to the default values.

| Parameter | Name                  | Factory Value | Setting Range | Content   |
|-----------|-----------------------|---------------|---------------|---|
| 00-02     | Parameter restoration | 0             | 0             | No function.  |
|           |                       |               | 1             | Alarm history clear (P.996=1)                           |
|           |                       |               | 2             | Inverter reset (P.997=1)                                |
|           |                       |               | 3             | Restoring all parameters to default values (P.998=1)    |
|           |                       |               | 4             | Restoring some parameters to default values1(P.999=1)   |
|           |                       |               | 5             | Restoring some parameters to default values 2 (P.999=2) |
|           |                       |               | 6             | Restoring some parameters to default values 3(P.999=3)  |

Setting Parameter restoration

- ◆ 1: 00-02 is set to 1, and the screen will display **Er.CC** after writing, the abnormal record will be erased, 00-02 is restored to 0.
- ◆ 2: 00-02 is set to 1, and the screen will display **rEST**, the inverter will be reset.00-02 is restored to 0.After resetting the inverter, the values of the two relays, “electronic thermal relay” and “IGBT module thermal relay”will be set to zero.
- ◆ 3: 00-02is set to3, and the screen will display **ALLC**, all the parameters will be restored to the default values except the parameters in the **table 1** below. After parameters are restored, 00-02 is restored to0.

**Exception**The parameters in **table 1** below will not be restored to the default values:

| Group | No.   | Name  |
|-------|-------|---|
| 00-00 | P.90  | The inverter model                          |
| 00-01 | P.188 | Firmware version                            |
| 00-24 | P.189 | 50Hz/60Hz switch selection                  |
| 01-08 | P.21  | Accelerate/Decelerate time increments       |
| 06-27 | P.292 | Accumulative motor operation time (minutes) |
| 06-28 | P.293 | Accumulative motor operation time (days)    |
| 06-29 | P.296 | Inverter electric time (minutes)            |
| 06-30 | P.297 | Inverter electric time (day)                |

- ◆ 4: 00-02 is set to4, and the screen will display **Pr.Cr** after writing, all the parameters will be restored to the default values except the parameters in the **table 1** and **table 2**below.After parameters are restored, 00-02is restored to 0.

**Exception** The parameters in **table 2** below and **table 1**will not are restored to the default values:

| Group | No.   | Name   |
|-------|-------|--|
| 00-21 | P.300 | Motor control mode selection   |
| 02-25 | P.198 | The minimum input current/voltage of 3-5                                 |
| 02-26 | P.199 | The maximum input current/voltage of 3-5                                 |
| 02-27 | P.196 | The percentagecorresponding tothe minimum input current/voltage of 3-5   |
| 02-28 | P.197 | The percentage corresponding to the maximum input current/voltage of 3-5 |

| Group | No.   | Name   |
|-------|-------|--|
| 02-61 | P.141 | 3-5 current/voltage input corresponding to the percentage of plus or minus |
| 05-00 | P.301 | Motor parameter auto-tuning function selection                             |
| 05-01 | P.302 | Motor rated power  |
| 05-02 | P.303 | Motor poles  |
| 05-03 | P.304 | Motor rated voltage  |
| 05-04 | P.305 | Motor rated frequency  |
| 05-05 | P.306 | Motor rated current  |
| 05-06 | P.307 | Motor rated rotation speed   |
| 05-07 | P.308 | Motor excitation current   |
| 05-08 | P.309 | Motor stator resistance  |
| 11-00 | P.320 | Slip compensation gain   |
| 11-01 | P.321 | Torque compensation filter coefficients                                    |

- ◆ 5 : The parameter user register between 15-00 and 15-19 will not be reset, nor will the value of parameter number. The parameter in table 1 will not be reset. Once reset, 00-02 will recover to 0.
- ◆ 6: The parameter user register between 15-00 and 15-19 will not be reset, nor will the value of parameter number. The parameter in table 1 and table2 will not be reset. Once reset, 00-02 will recover to 0.

Note: When restoring all or some to default values, please be sure that the screen displays *End*, which means parameters has been restored to factory values, and then execute other operations.

## 5.1.3 Parameter protection

- ◆ Whether to enable the writing to various parameters or not can be selected. Use this function to prevent parameter values from being rewritten by disoperation.

| Parameter      | Name                                     | Factory Value | Setting Range | Content  |
|----------------|--|---------------|---------------|--|
| 00-03<br>P.77  | Selection of parameters write protection | 0             | 0             | Parameters can be written only when the motor stops.               |
|                |  |               | 1             | Parameters cannot be written.                                      |
|                |  |               | 2             | Parameters can also be written when the motor is running.          |
|                |  |               | 3             | Parameters cannot be written when in password protection.          |
| 00-04<br>P.294 | Decryption parameter                     | 0             | 0~65535       | Write the registered password to decrypt the parameter protection. |
| 00-05<br>P.295 | Password setup                           | 0             | 2~65535       | Register password for parameter protection setting.                |

Settin Parameter write protectionselection

- ◆ Writing parameters only during stop(00-03="0"initial value)

**Exception** During operation, the parameters below can be written:

| Group | No.   | Name   |
|-------|-------|--|
| 00-03 | P.77  | Selection of parameters write protection                                 |
| 00-07 | P.161 | Multi-function display   |
| 02-25 | P.198 | The minimum input current/voltage of 3-5                                 |
| 02-26 | P.199 | The maximum input current/voltage of 3-5                                 |
| 02-27 | P.196 | The percentage corresponding to the minimum input current/voltage of 3-5 |
| 02-28 | P.197 | The percentage corresponding to the maximum input current/voltage of 3-5 |
| 02-52 | P.56  | Output current display reference   |
| 04-00 | P.4   | Speed 1 ( high speed )   |
| 04-01 | P.5   | Speed 2 (middle speed)   |
| 04-02 | P.6   | Speed 3 (low speed)  |
| 04-03 | P.24  | Speed 4  |
| 04-04 | P.25  | Speed 5  |
| 04-21 | P.133 | Programmed operation mode speed3   |
| 04-22 | P.134 | Programmed operation mode speed 4  |
| 04-23 | P.135 | Programmed operation mode speed 5  |
| 04-24 | P.136 | Programmed operation mode speed 6  |
| 04-25 | P.137 | Programmed operation mode speed 7  |
| 04-26 | P.138 | Programmed operation mode speed 8  |

| Group | No.   | Name                              |
|-------|-------|-----------------------------------|
| 04-05 | P.26  | Speed 6                           |
| 04-06 | P.27  | Speed7                            |
| 04-07 | P.142 | Speed8                            |
| 04-08 | P.143 | Speed9                            |
| 04-09 | P.144 | Speed10                           |
| 04-10 | P.145 | Speed11                           |
| 04-11 | P.146 | Speed12                           |
| 04-12 | P.147 | Speed13                           |
| 04-13 | P.148 | Speed14                           |
| 04-14 | P.149 | Speed15                           |
| 04-19 | P.131 | Programmed operation mode speed 1 |
| 04-20 | P.132 | Programmed operation mode speed 2 |
| 06-17 | P.261 | Maintenance alarm function        |
| 08-03 | P.225 | PID target value panel reference  |
| 10-19 | P.230 | Dwell frequency at acceleration   |
| 10-21 | P.232 | Dwell frequency at deceleration   |
| 10-19 | P.230 | Dwell frequency at acceleration   |
| 10-21 | P.232 | Dwell frequency at deceleration   |

- ◆ The parameters cannot be written. (00-03="1")

**Exception** The parameters below can be written.

| Group | No.  | Name                                     |
|-------|------|--|
| 00-03 | P.77 | Selection of parameters write protection |

| Group | No.  | Name                     |
|-------|------|--------------------------|
| 00-16 | P.79 | Operation mode selection |

- ◆ During operation, the parameters below can also be written.(00-03="2")

**Exception** During operation, the parameters below cannot be written:

| Group | No.   | Name  |
|-------|-------|---|
| 00-00 | P.90  | The inverter model                            |
| 00-01 | P.188 | Firmware version                              |
| 00-11 | P.72  | Carrier frequency                             |
| 00-15 | P.78  | Forward/reverse rotation prevention selection |
| 00-16 | P.79  | Operation mode selection                      |
| 06-01 | P.22  | Stall prevention operation level              |
| 06-08 | P.155 | Over torque detection level                   |

| Group | No.   | Name  |
|-------|-------|---|
| 06-27 | P.292 | Accumulative motor operation time (minutes) |
| 06-28 | P.293 | Accumulative motor operation time (days)    |
| 06-41 | P.289 | Alarm code display                          |
| 06-43 | P.291 | Alarm message display                       |
| 06-29 | P.296 | Inverter electric time (minutes)            |
| 06-30 | P.297 | Inverter electric time (days)               |

- ◆ When in password protection, parameters cannot be read. (00-03="3")

**Exception** The parameters below can still be read:

| Group | No.   | Name                     |
|-------|-------|--------------------------|
| 00-00 | P.90  | The inverter model       |
| 00-01 | P.188 | Firmware version         |
| 00-05 | P.295 | Password setup           |
| 00-08 | P.37  | Speed display            |
| 00-16 | P.79  | Operation mode selection |
| 00-25 | P.990 | Parameter mode setting   |
| 01-00 | P.1   | Maximum frequency        |
| 01-01 | P.2   | Minimum frequency        |
| 06-41 | P.289 | Alarm code display       |
| 06-43 | P.291 | Alarm message display    |

Setting Password protection

- ◆ Registering a password
  1. Write a number (2 ~ 65535) in 00-05 as a password, password protection takes effect immediately;
  2. After registering a password, 00-05=1;
- ◆ Unlocking password protection
  1. Write the correct password in 00-04, and then password protection will be unlocked;
  2. After unlocking the password, 00-04=0, 00-05=1;
  3. If turn the inverter power off and then turn on, it will still restore to the password protection status.
- ◆ Password all clear
  1. Write the correct password in 00-04 to unlock the password protection;
  2. Write 0 in 00-05, password will be all cleared.

Note: Please keep the password properly. Bring the inverter to the factory for decryption if the password is forgotten.

## 5.1.4 Monitoring function

- ◆ The item to be displayed on the operation panel can be selected.

| Parameter      | Name                                 | Factory Value | Setting Range | Content  |
|----------------|--------------------------------------|---------------|---------------|--|
| 00-06<br>P.110 | Operation panel monitoring selection | 1             | 0             | When the inverter starts, the operation panel enters the monitoring mode automatically, and the screen displays the output frequency.                  |
|                |                                      |               | 1             | When the inverter starts, the screen of the operation panel displays the target frequency.   |
|                |                                      |               | 2             | When the inverter starts, the operator shows the current target frequency.   |
|                |                                      |               | 3             | When the inverter starts, operator begins monitor mode automatically, display the current target pressure and feedback constant pressure system (note) |
|                |                                      |               | 4             | When the inverter starts, operator is no longer automatically monitor mode, display the inverter model before starting.                                |
| 00-07<br>P.161 | Multi-function display               | 0             | 0             | Output voltage (V)   |
|                |                                      |               | 1             | DC bus voltage (V)   |
|                |                                      |               | 2             | Temperature rising accumulation rate of inverter (%)   |
|                |                                      |               | 3             | Target pressure of the constant pressure system (%)  |
|                |                                      |               | 4             | Feedback pressure of the constant pressure system (%)  |
|                |                                      |               | 5             | Operation frequency (Hz)   |
|                |                                      |               | 6             | Electronic thermal accumulation rate (%)   |
|                |                                      |               | 8             | Signal value (mA) of 3-5 simulating input terminals (mAVV).  |
|                |                                      |               | 9             | Output power (kW).   |
|                |                                      |               | 11            | Positive and reverse rotation signal. Then 1 represents positive rotation, 2 represents reverse rotation, and 0 represents stopping state.             |
|                |                                      |               | 12            | NTC temperature (°C)   |
|                |                                      |               | 13            | Electronic thermal accumulation rate of motor (%)  |
|                |                                      |               | 14~18         | Reserved.  |
|                |                                      |               | 19            | Digital terminal input state   |
| 20             | Digital terminal output state        |               |               |  |
| 21             | Actual working carrier frequency     |               |               |  |

Note: 1. The "output frequency" here is the value after slip compensation.

2. The multi-function display selection is realized in the monitoring voltage mode. Please refer to Section 4.2.3 for monitoring mode selection

3. Please refer to 5.4.15 for the sort of terminal.

### Display Operation panel monitoringselection

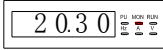
- ◆ Display the current target pressure and feedback pressure of the constant pressure system(00-06="3"). At this point, the screen display shows two sections. A decimal point is used to separate the boundaries. What is on the left is the target pressure of the constant pressure system and what is on the right is the feedback pressure of the constant pressure system. As is shown in this figure, , 20 denotes that the target pressure of the constant pressure system is 2.0kg/cm<sup>3</sup>; 30 denotes that the feedback pressure of the constant pressure system is 3.0kg/cm<sup>3</sup>.

### Display Multi-function display

- ◆ The multi-function display selection is realized in the monitoring voltage mode. Please refer toPage 66(4.2.3 the operation flow charts for monitoring mode)for monitoring mode selection.

## 5.1.5 Speed display

- ◆ In the mode of "monitoring output frequency", the screen displays the corresponding machine speed.

| Parameter      | Name                 | Factory Value | Setting Range | Content  |
|----------------|----------------------|---------------|---------------|--|
| 00-08<br>P.37  | Speed display        | 0.0           | 0             | 0: Display output frequency(the mechanical speed is not displayed) |
|                |                      |               | 0.1~5000.0    | When 00-09=1   |
|                |                      |               | 1~9999        | When 00-09=0   |
| 00-09<br>P.259 | Speed unit selection | 1             | 0             | 0: Speed display selection unit is 1                               |
|                |                      |               | 1             | 1: Speed display selection unit is 0.1                             |

### Settin Speed display

- ◆ The setting value of 00-08 is the machine speed of the inverter when its output frequency is 60Hz.  
For example:
  1. If the transmitting belt speed is 950 m/minute when the inverter output frequency is 60Hz, set 00-08 = 950.
  2. After setting, in the "output frequency monitoring mode" of operation panel, the screen will display the speed of the transmitting belt.

Note: The machine speed on the screen is the theoretical value calculated proportionately by the inverter output frequency and the setting value of 00-08. So there's minute discrepancy between the displayed machine speed and the actual one.

### 5.1.6 The Setting Frequency Selection of Rotary Knob on the Operating Keyboard

◆ According the different setting values determining the frequency values which are set by the keyboard.

| Parameter     | Name   | Factory Value | Setting Range | Content  |
|---------------|--|---------------|---------------|--|
| 00-10<br>P.59 | The setting frequency selection of rotary knob on the operating keyboard | 0             | XXX0          | The frequency set by frequency inverter itself shuttle knob is effective                 |
|               |  |               | XXX1          | The frequency set by the knob of the manipulator is effective.                           |
|               |  |               | X0XX          | After changing the frequency, automatic storage after 30s.                               |
|               |  |               | X1XX          | After changing the frequency, automatic storage after 10s.                               |
|               |  |               | X2XX          | After changing the frequency, don'tstore automatically                                   |
|               |  |               | 0XXX          | After to shuttle set frequency, the frequency of changes take effect immediately         |
|               |  |               | 1XXX          | After to shuttle set frequency and the set key run, the frequency of change take effect. |

#### Setting The Setting of Rotary Knob on the Operating keyboard

◆ 00-27 ( P.59 ) is set by bit and it has 4 bits.

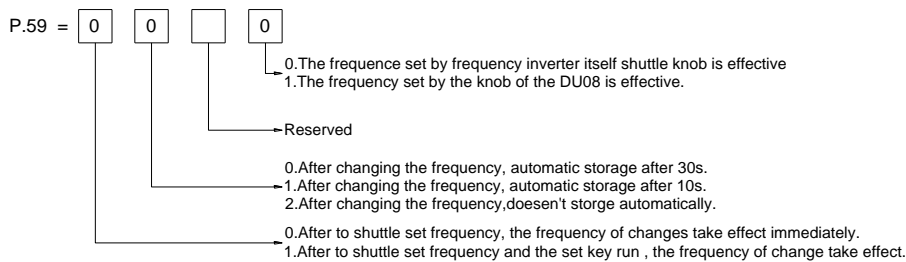

Note: : On one hundred - bit value, value on ontology shuttle knob set frequency effectively.

### 5.1.7 PWM Carrier frequency

◆ The motor sound can be changed by adjusting PWM carrier frequency properly.

| Parameter     | Name                                 | Factory Value | Setting Range | Content  |
|---------------|--------------------------------------|---------------|---------------|--|
| 00-11<br>P.72 | Carrier frequency                    | 5kHz          | 1~15          |  |
| 00-12<br>P.31 | Soft-PWM carrier operation selection | 0             | 0             | None Soft-PWM operation  |
|               |                                      |               | 1             | When 00-11(P.72)< 5, Soft-PWM is valid(only apply to V/F control )   |
|               |                                      |               | 2             | When P.72>9, Inverter module's temperature is exorbitant, carrier will automatically lower, after module's temperature dropping, carrier will automatically return to P. 72 set value. |

#### Setting Carrier frequency

- ◆ If the carrier frequency becomes larger, the mechanical noise of motor will become smaller, the leakage current of motor will become larger, and the noise of inverter will become larger.
- ◆ If the carrier frequency becomes larger, the inverter will consume more energy and its temperature will also rise.
- ◆ If there is mechanical resonance in inverter systems, we can adjust the setting value of 00-11 to diminish it.

- ◆ The higher Carrier frequency, the inverter rated current will decline, which was to prevent the inverter to overheat and extend the life of IGBT, so that protection measures are necessary. The carrier frequency is 8kHz or below, rated current of a inverter is 100%, as the carrier frequency increase, rating current will decline, and accelerate product heat to protect the inverter. Rated current and carrier frequency relation curve shown in the following figure:

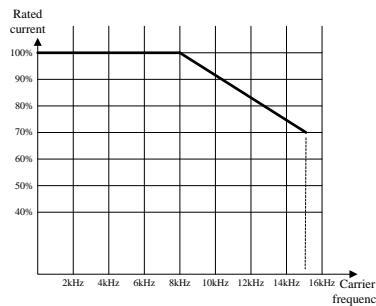

Note: carrier frequency value should at least 8 times exceed the target frequency more than double.

**Setting Carrier operation selection V/F**

- ◆ Soft-PWM control is a control method that changes the motor noise from a metallic sound into an inoffensive, complex tone.
- ◆ Motor noise modulation control is when the inverter varies its carrier frequency from time to time during the operation. The metal noises generated by the motor are not a single frequency. This function selection is to improve the high peak single frequency noises.
- ◆ This function is only valid under the V/F mode; i.e., it is effective when 00-21=0.

5.1.8 Stop operation selection

- ◆ Select the inverter stop operation

| Parameter     | Name                                | Factory Value | Setting Range | Content  |
|---------------|-------------------------------------|---------------|---------------|--|
| 00-13<br>P.71 | Idling braking /<br>DC braking      | 1             | 0             | Idling braking   |
|               |                                     |               | 1             | DC braking   |
| 00-14<br>P.75 | STOP<br>RESET function<br>selection | 1             | 0             | Press <b>STOP<br/>RESET</b> button and stop the operation only in the PU and H2 (combined mode 2) mode |
|               |                                     |               | 1             | Press <b>STOP<br/>RESET</b> button and stop the operation in all mode.                                 |

**Setting Idling braking / linear braking**

- ◆ Idling braking(00-13="0")

The inverter will terminate the output immediately after the stop signal is accepted, and the motor will be "racing".

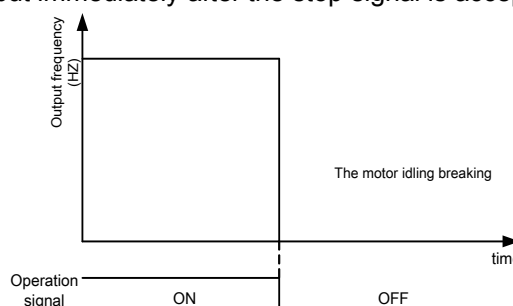

- ◆ Linear braking(00-13="1")

## System parameter group00

The output of the inverter will follow the acceleration/deceleration curve to decelerate until stop after the stop signal is accepted.

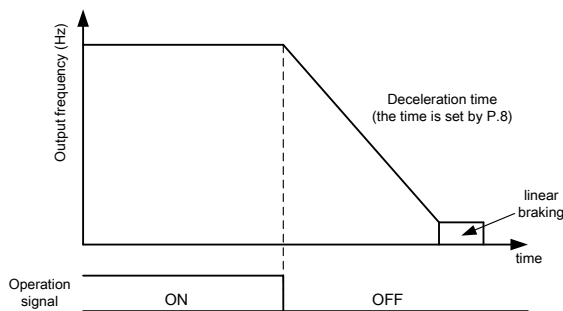

### Setting Button function selection

- ◆  to stop the operation.(00-14="1")

**Notice** In any modes except the PU and the H2 mode, the motor can be stopped by pressing . The inverter then displays E0 and all functions of the inverter are disabled. To unlock the state, follow the procedures below:

1. If the start signal is the digital input terminal, it is necessary to cancel the digital input start signal given(Note1);
2. Press  button for over 1.0 second to remove E0 state.

- ◆ No matter in which setting, press  button for over 1.0 second to reset the inverter after the alarm occurs.

Note: 1. In the programmed operation mode, it is not necessary to cancel the start signal. The inverter will run at the section where it stopped after reset.)

2. After resetting the inverter, the values of the two relays of "electronic thermal relay" and "IGBT module thermal relay" will be set to zero.

### 5.1.9 Forward/reverse rotation prevention selection

- ◆ Set this parameter to limit the motor rotation to only one direction, and prevent reverse rotation fault resulting from the incorrect input of the start signal.

| Parameter     | Name  | Factory Value | Setting Range | Content   |
|---------------|---|---------------|---------------|---|
| 00-15<br>P.78 | Forward/reverse rotation prevention selection | 0             | 0             | Forward rotation and reverse rotation are both permitted.   |
|               |   |               | 1             | Reverse rotation is prohibited (Press the reverse reference to decelerate and stop the motor).          |
|               |   |               | 2             | Forward rotation is prohibited (Press the forward rotation reference to decelerate and stop the motor). |

Note: It is valid to all start signals.

### 5.1.10 Operation mode selection

- ◆ Select the operation mode of the inverter, and determine the source of start signal and target frequency.

| Parameter     | Name                                     | Factory Value | Setting Range | Content   |
|---------------|--|---------------|---------------|---|
| 00-16<br>P.79 | Operation mode selection                 | 0             | 0             | "PU mode", "external mode" and "Jog mode" are interchangeable.                              |
|               |  |               | 1             | "PU mode" and "JOG mode" are interchangeable.   |
|               |  |               | 2             | "External mode" only  |
|               |  |               | 3             | "Communication mode" only   |
|               |  |               | 4             | "Combined mode 1"   |
|               |  |               | 5             | "Combined mode 2"   |
|               |  |               | 6             | "Combined mode 3"   |
|               |  |               | 7             | "Combined mode 4"   |
| 00-17<br>P.97 | The second target frequency selection    | 0             | 0             | Frequency set by operation panel  |
|               |  |               | 1             | Frequency set by Communication RS485  |
|               |  |               | 2             | Frequency set by the analog   |
| 00-19<br>P.35 | Communication mode instruction selection | 0             | 0             | In communication mode, operating instruction and setting frequency is set by communication. |
|               |  |               | 1             | In communication mode, operating instruction and setting frequency is set by external.      |

 Operation mode selection

- ◆ Please refer to Section 4.3 for the detailed setting and usage.

 Communication mode instruction selection

- ◆ When 00-16=3, select communication mode:
  1. If 00-19=0, operating instruction and speed instruction is set by communication;
  2. If 00-19=1, operating instruction and speed instruction is set by external.

### 5.1.11 Control mode selection

- ◆ Determine the control mode of the selected AC motor inverter

| Parameter      | Name                         | Factory Value | Setting Range | Content  |
|----------------|------------------------------|---------------|---------------|--|
| 00-21<br>P.300 | Motor control mode selection | 0             | 0             | Induction motor V/F control                        |
|                |                              |               | 2             | General magnetic vector control of induction motor |

 Control mode selection

- ◆ Induction motor V/F control: The user can design V/F ratio by self with the demand, and at the same time control motors.
- ◆ General magnetic vector control of induction motor: The voltage boost, the frequency changes when compensation motor load increases.

Note: 1. Motor capacity shall be same level or lower level with inverter capacity.

2. When making automatic measurement, such as allowing the motor rotation, please set the P.301 = 1 (dynamic measurement), the load and the motor must be made out completely. Such as load environment don't allow Auto - tuning automatically measure when motor rotate, please set the P. 301 = 2 (static measurement).
3. Domestic magnetic to quantity control: According to function of the automatic measurement (Auto - tuning) to enhance the control performance.

### 5.1.12 50/60Hz switch selection

- ◆ According to different power frequency and the default motor frequency, frequency-related parameters which are 50Hz or 60Hz can be selected.

| Parameter      | Name                     | Factory Value | Setting Range | Content   |
|----------------|--------------------------|---------------|---------------|---|
| 00-24<br>P.189 | 50/60Hz switch selection | 0             | 0             | The frequency parameter default value is 60Hz system. |
|                |                          | 1             | 1             | The frequency parameter default value is 50Hz system. |

#### Setting 50/60Hz switch selection

- ◆ If the customer would like to set frequency related parameter to 60Hz system (00-24="0"), please follow the following two steps.
  1. Set 00-24=0;
  2. Set 00-02 to the factory default value (at this point, frequency-related parameters of the inverter will be reset to 60Hz).
- ◆ The affected parameters are as follows:

| Group | No.  | Name  |
|-------|------|---|
| 01-03 | P.3  | Base frequency                                  |
| 01-09 | P.20 | Accelerate/decelerate reference frequency       |
| 02-21 | P.39 | The maximum operation frequency of terminal 3-5 |

| Group | No.   | Name  |
|-------|-------|---|
| 05-04 | P.305 | Motor rated frequency                                   |
| 05-06 | P.307 | Motor rated rotation speed                              |
| 06-03 | P.66  | Stall prevention operation reduction starting frequency |
| 08-14 | P.182 | Integral upper limit                                    |

## 5.1.13 Parameter mode setting

- ◆ Select “order number” or “parameter group” to display parameters.

| Parameter      | Name                   | Factory Value | Setting Range | Content   |
|----------------|------------------------|---------------|---------------|---|
| 00-25<br>P.990 | Parameter mode setting | 0             | 0             | Parameter is displayed as “group mode”          |
|                |                        |               | 1             | Parameter is displayed as “conventional P mode” |

Display Parameter mode setting

- ◆ “Parameter group” displaying

00 - 25 PU MON RUN  
Hz A V

- ◆ “Order number” displaying

p. 0 PU MON RUN  
Hz A V

## 5.2 Basic parameter group01

| Group | Parameter Number | Name  | Setting Range   | Factory Value | Page |
|-------|------------------|---|---|---------------|------|
| 01-00 | P.1              | Maximum frequency                             | 0.00 ~ 01-02(P.18)Hz  | 120.00Hz      | 62   |
| 01-01 | P.2              | Minimum frequency                             | 0 ~ 120.00Hz  | 0.00Hz        | 62   |
| 01-02 | P.18             | High-speed maximum frequency                  | 01-00(P.1) ~ 650.00Hz   | 120.00Hz      | 62   |
| 01-03 | P.3              | Base frequency                                | 50Hz system setting: 0 ~ 650.00Hz                             | 50.00Hz       | 63   |
|       |                  |   | 60Hz system setting: 0 ~ 650.00Hz                             | 60.00Hz       |      |
| 01-04 | P.19             | Base frequency voltage                        | 0 ~ 1000.0V   | 99999         | 63   |
|       |                  |   | 99999: Change according to the input voltage                  |               |      |
| 01-05 | P.29             | Acceleration/deceleration curve selection     | 0: Linear acceleration /deceleration curve                    | 0             | 64   |
|       |                  |   | 1: S pattern acceleration /deceleration curve 1               |               |      |
|       |                  |   | 2: S pattern acceleration /deceleration curve 2               |               |      |
|       |                  |   | 3: S pattern acceleration /deceleration curve 3               |               |      |
| 01-06 | P.7              | Acceleration time                             | 3.7K and types below: 0 ~ 360.00s/0 ~ 3600.0s                 | 5.00s         | 64   |
|       |                  |   | 5.5K types: 0 ~ 360.00s/0 ~ 3600.0s                           | 10.00s        |      |
| 01-07 | P.8              | Deceleration time                             | 3.7K and types below: 0 ~ 360.00s/0 ~ 3600.0s                 | 5.00s         | 64   |
|       |                  |   | 5.5K types: 0 ~ 360.00s/0 ~ 3600.0s                           | 10.00s        |      |
| 01-08 | P.21             | Acceleration/deceleration time increments     | 0: Time increments 0.01s                                      | 0             | 64   |
|       |                  |   | 1: Time increment is 0.1s                                     |               |      |
| 01-09 | P.20             | Acceleration/deceleration reference frequency | 50Hz system setting: 1.00 ~ 650.00Hz                          | 50.00Hz       | 64   |
|       |                  |   | 60Hz system setting: 1.00 ~ 650.00Hz                          | 60.00Hz       |      |
| 01-10 | P.0              | Torque boost                                  | 0.2K~0.75K types: 0 ~ 30.0%                                   | 6.0%          | 66   |
|       |                  |   | 1.5K ~ 3.7K types: 0 ~ 30.0%                                  | 4.0%          |      |
|       |                  |   | 5.5K types: 0 ~ 30.0%   | 3.0%          |      |
| 01-11 | P.13             | Starting frequency                            | 0 ~ 60.00Hz   | 0.50Hz        | 66   |
| 01-12 | P.14             | Load pattern selection                        | 0: Applicable to constant torque loads(convey belt, etc.)     | 0             | 67   |
|       |                  |   | 1: Applicable to variable torque loads (fans and pumps, etc.) |               |      |
|       |                  |   | 2、3:Applicable to ascending / descending loads                |               |      |
|       |                  |   | 4:Multipoint VF curve   |               |      |
|       |                  |   | 5 ~ 13:Special two-point VF curve                             |               |      |
| 01-13 | P.15             | JOG frequency                                 | 0 ~ 650.00Hz  | 5.00Hz        | 69   |
| 01-14 | P.16             | JOG acceleration/ deceleration time           | 0 ~ 360.00s/0 ~ 3600.0s                                       | 0.50s         | 69   |
| 01-15 | P.28             | Output frequency filter time                  | 0 ~ 1000ms  | 0ms           | 69   |
| 01-16 | P.91             | Frequency jump 1A                             | 0 ~ 650.00Hz  | 99999         | 70   |
|       |                  |   | 99999: invalid  |               |      |
| 01-17 | P.92             | Frequency jump 1B                             | 0 ~ 650.00Hz  | 99999         | 70   |
|       |                  |   | 99999: invalid  |               |      |
| 01-18 | P.93             | Frequency jump 2A                             | 0 ~ 650.00Hz  | 99999         | 70   |
|       |                  |   | 99999: invalid  |               |      |

| Group | Parameter Number | Name  | Setting Range           | Factory Value | Page |
|-------|------------------|---|-------------------------|---------------|------|
| 01-19 | P.94             | Frequency jump 2B                               | 0 ~ 650.00Hz            | 99999         | 70   |
|       |                  |   | 99999: invalid          |               |      |
| 01-20 | P.95             | Frequency jump 3A                               | 0 ~ 650.00Hz            | 99999         | 70   |
|       |                  |   | 99999: invalid          |               |      |
| 01-21 | P.96             | Frequency jump 3B                               | 0 ~ 650.00Hz            | 99999         | 70   |
|       |                  |   | 99999: invalid          |               |      |
| 01-22 | P.44             | The second acceleration time                    | 0 ~ 360.00s/0 ~ 3600.0s | 99999         | 71   |
|       |                  |   | 99999: Not selected     |               |      |
| 01-23 | P.45             | The second deceleration time                    | 0 ~ 360.00s/0 ~ 3600.0s | 99999         | 71   |
|       |                  |   | 99999: Not selected     |               |      |
| 01-24 | P.46             | The second torque boost                         | 0 ~ 30.0%               | 99999         | 71   |
|       |                  |   | 99999: Not selected     |               |      |
| 01-25 | P.47             | The second base frequency                       | 0 ~ 650.00Hz            | 99999         | 71   |
|       |                  |   | 99999: Not selected     |               |      |
| 01-26 | P.98             | Middle frequency 1                              | 0 ~ 650.00Hz            | 3.00Hz        | 72   |
| 01-27 | P.99             | Output voltage 1 of middle frequency            | 0 ~ 100.0%              | 10.0%         | 72   |
| 01-28 | P.162            | Middle frequency 2                              | 0 ~ 650.00Hz            | 99999         | 72   |
|       |                  |   | 99999: Not selected     |               |      |
| 01-29 | P.163            | Output voltage 2 of middle frequency            | 0 ~ 100.0%              | 0.0%          | 72   |
| 01-30 | P.164            | Middle frequency 3                              | 0 ~ 650.00Hz            | 99999         | 72   |
|       |                  |   | 99999: Not selected     |               |      |
| 01-31 | P.165            | Output voltage 3 of middle frequency            | 0 ~ 100.0%              | 0.0%          | 72   |
| 01-32 | P.166            | Middle frequency 4                              | 0 ~ 650.00Hz            | 99999         | 72   |
|       |                  |   | 99999: Not selected     |               |      |
| 01-33 | P.167            | Output voltage 4 of middle frequency            | 0 ~ 100.0%              | 0.0%          | 72   |
| 01-34 | P.168            | Middle frequency 5                              | 0 ~ 650.00Hz            | 99999         | 72   |
|       |                  |   | 99999: Not selected     |               |      |
| 01-35 | P.169            | Output voltage 5 of middle frequency            | 0 ~ 100.0%              | 0.0%          | 72   |
| 01-36 | P.255            | S pattern time at the beginning of acceleration | 0 ~ 25.00s/0 ~ 250.0s   | 0.20s         | 73   |
| 01-37 | P.256            | S pattern time at the end of acceleration       | 0 ~ 25.00s/0 ~ 250.0s   | 99999         | 73   |
|       |                  |   | 99999: Not selected     |               |      |
| 01-38 | P.257            | S pattern time at the beginning of deceleration | 0 ~ 25.00s/0 ~ 250.0s   | 99999         | 73   |
|       |                  |   | 99999: Not selected     |               |      |
| 01-39 | P.258            | S pattern time at the end of deceleration       | 0 ~ 25.00s/0 ~ 250.0s   | 99999         | 73   |
|       |                  |   | 99999: Not selected     |               |      |

## 5.2.1 Limiting the output frequency

- ◆ Output frequency can be limited. Clamp the output frequency at the upper and lower limits.

| Parameter     | Name                         | Factory Value | Setting Range            | Content                  |
|---------------|------------------------------|---------------|--------------------------|--------------------------|
| 01-00<br>P.1  | Maximum frequency            | 120.00Hz      | 0.00 ~<br>01-02(P.18)Hz  |                          |
| 01-01<br>P.2  | Minimum frequency            | 0.00Hz        | 0 ~ 120.00Hz             | Output minimum frequency |
| 01-02<br>P.18 | High-speed maximum frequency | 120.00Hz      | 01-00(P.1) ~<br>650.00Hz | Set when above 120Hz     |

**Setting** Maximum frequency, high-speed maximum frequency

- ◆ The “maximum frequency” and the “high-speed maximum frequency” are interrelated:
  1. If the target upper limit frequency is set below 01-00(P.1), use 01-00 as the maximum frequency;
  2. If the target frequency limited to between 120~650Hz, use 01-02 as the maximum frequency.
- ◆ If  $01-00 < 01-01$ , the steady output frequency will be clamped to 01-00.
- ◆ When setting the target frequency in PU mode, the set frequency value cannot exceed the value of 01-00.

**Setting** Minimum frequency

- ◆ If the target frequency  $\leq 01-01$ , the steady output frequency equals to = 01-01.
- ◆ If  $01-01 < \text{target frequency} \leq 01-00$  (01-03), the steady output frequency equals to target frequency.

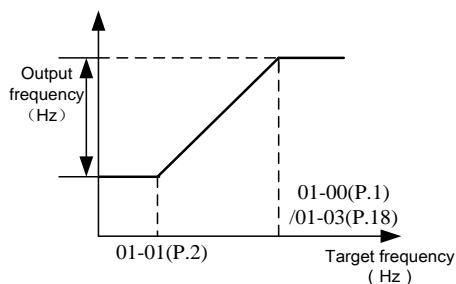

## 5.2.2 Base frequency, base frequency voltage

- ◆ Use this function to adjust the inverter outputs (voltage, frequency) to match with the motor rating.

| Parameter     | Name                   | Factory Value | Setting Range   | Content  |
|---------------|------------------------|---------------|-----------------|--|
| 01-03<br>P.3  | Base frequency         | 50.00Hz       | 0.00 ~ 650.00Hz | 50Hz system (00-24=1)  |
|               |                        | 60.00Hz       |                 | 60Hzsystem (00-24=0)   |
| 01-04<br>P.19 | Base frequency voltage | 99999         | 0 ~ 1000.0V     | Set the base frequency voltage according to the motor rating.    |
|               |                        |               | 99999           | The base frequency voltage is equal to the power source voltage. |

### Setting Base frequency

- ◆ Generally set the rated frequency of the motor in 01-03.  
When the frequency on the motor rating plate is only "50 Hz", make sure to set to "50 Hz". When it is set to "60 Hz", the voltage will drop too much, causing insufficient torque. As a result, the inverter may trip due to overload.
- ◆ When the motor operation require switching to commercial power supply, set commercial power supply in 01-03.

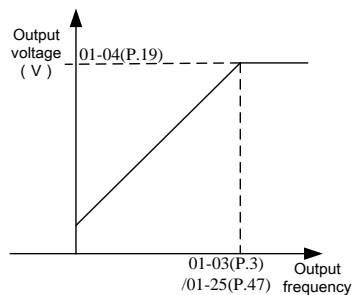

Note: Please refer to 5.2.10 The second function for the second base frequency.

### Setting Base frequency voltage

- ◆ If the output frequency is lower than the base frequency, the output voltage of the inverter will increase with output frequency. If the output frequency has reached the base frequency (01-03), the output voltage will just be equal to the base frequency voltage. If the output frequency exceeds the base frequency and increase continuously, the output voltage will be clamped to the base frequency voltage.

5.2.3 Acceleration/deceleration time setting

◆ Use this function to set motor acceleration/deceleration time.

| Parameter     | Name  | Factory Value | Setting Range   | Content   |
|---------------|---|---------------|-----------------|---|
| 01-05<br>P.29 | Acceleration/deceleration curve selection     | 0             | 0               | Linear acceleration /deceleration curve               |
|               |   |               | 1               | S pattern acceleration /deceleration curve 1 (Note 1) |
|               |   |               | 2               | S pattern acceleration /deceleration curve 2 (Note 2) |
|               |   |               | 3               | S pattern acceleration /deceleration curve 3 (Note 3) |
| 01-06<br>P.7  | Acceleration time                             | 5.00s         | 0 ~ 360.00s     | 3.7K and types below                                  |
|               |   | 10.00s        | 0 ~ 3600.0s     | 5.5K types  |
| 01-07<br>P.8  | Deceleration time                             | 5.00s         | 0 ~ 360.00s     | 3.7K and types below                                  |
|               |   | 10.00s        | 0 ~ 3600.0s     | 5.5K types  |
| 01-08<br>P.21 | Acceleration/deceleration time increments     | 0             | 0               | Time increment is 0.01s                               |
|               |   |               | 1               | Time increment is 0.1s                                |
| 01-09<br>P.20 | Acceleration/deceleration reference frequency | 50.00Hz       | 1.00 ~ 650.00Hz | 50Hz system setting (00-24=1)                         |
|               |   | 60.00Hz       |                 | 60Hz system setting(00-24=0)                          |

Setting Acceleration/deceleration curve selection

◆ Linear acceleration /deceleration curve(01-05="0")

An acceleration slope is constructed by the combination of 01-06 and 01-09. A deceleration slope is constructed by the combination of 01-06 and 01-09.

When the target frequency varies, it increases with the "acceleration slope" or decreases with the "deceleration slope" linearly. See the figure below:

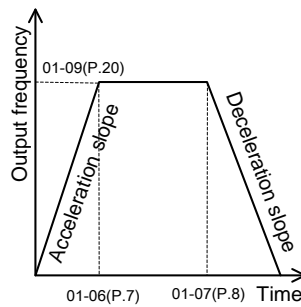

◆ S pattern acceleration /deceleration curve 1(01-05="1")

An acceleration slope is constructed by the combination of 01-06 and 01-03. A deceleration slope is constructed by the combination of 01-07 and 01-03.

The acceleration / deceleration curve has an S-shape change according to the "acceleration / deceleration slope".

The S-shape equation between 0 and 01-03(P.3) is:

$$f = [1 - \cos(\frac{90^\circ \times t}{P.7})] \times P.3$$

The S-shape equation of 01-03(P.3) or above is:

$$t = \frac{4}{9} \times \frac{P.7}{(P.3)^2} \times f^2 + \frac{5}{9} \times P.7$$

t = time; f = output frequency

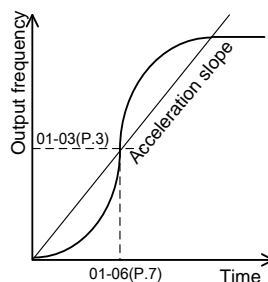

◆ S pattern acceleration /deceleration curve 2(01-05=2)

An acceleration slope is formed by the combination of 01-06 and 01-09. A deceleration slope is formed by the combination of 01-07 and 01-09.

When the target frequency varies, the acceleration curve has an S-shape ascending according to the “acceleration slope”. The deceleration curve on the other hand has an S-shape deceleration according to the “deceleration slope”. As shown in the figure below, when the setting value of the inverter is adjusted from  $f_0$  to  $f_2$ , an S-shape acceleration is undertaken once, and the time is  $01-06 \times (f_2 - f_0) / 01-09$ . Then if the frequency is set from  $f_2$  to  $f_3$ , a second S-shape acceleration is experienced, and the time is  $01-06 \times (f_3 - f_2) / 01-09$ .

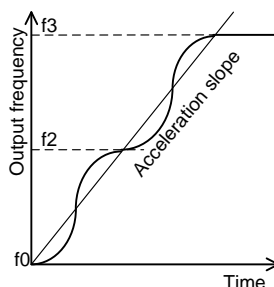

◆ S pattern acceleration /deceleration curve 3(01-05=“3”)

Please refer to 5.2.12 Spattern time setting.

Setting Acceleration/deceleration time increments

- ◆ When 01-08=0, minimum acceleration / deceleration time (01-06、01-07、01-14、01-22、01-23、04-35~04-42) increment is 0.01s.
- ◆ When 01-08=1, minimum acceleration / deceleration time(01-06、01-07、01-14、01-22、01-23、04-35~04-42)increment is 0.1s.

Setting Acceleration / deceleration reference frequency

- ◆ When the output frequency of the inverter is accelerated from 0Hz to 01-09, the required time is defined as “acceleration time”.
- ◆ When the output frequency of the inverter is decelerated from 0Hz to 01-09, the required time is defined as “deceleration time”.

Note: 1. S pattern acceleration /deceleration curve 1 is used when acceleration/deceleration is required for a short time until a high-speed area equal to or higher than the base frequency, such as for the main shaft of the machine.  
 2. S pattern acceleration /deceleration curve2 can effectively reduce motor vibration during the acceleration / deceleration, and thus prevent the belts and gears from broken.  
 3. S pattern acceleration /deceleration curve3 is used to start the inverter gradually without impact.  
 4. Please refer to Section 5.2.10 The second function for the second acceleration/deceleration time.  
 5. When RT is “on”, the second function is valid. For the operation characteristics of the motor, please refer to Section 5.2.10.RT mentioned in this section is the function name of the “multi-function digital input terminal”. Please refer to 03-00~03-06, 03-09 for function selection and purposes of the multi-function digital input terminal. For related wiring, please refer to Section 3.7.

### 5.2.4 Torque boost V/F

- ◆ For an inverter controlled by V/F mode, when the motor starts up, the starting torque is usually inadequate since the output voltage of the inverter is inadequate. In this case, the output voltage can be elevated by properly setting the torque boost (01-10), and thus a better starting torque can be acquired.

| Parameter    | Name         | Factory Value | Setting Range | Content     |
|--------------|--------------|---------------|---------------|-------------|
| 01-10<br>P.0 | Torque boost | 6.0%          | 0 ~ 30.0%     | 0.2 ~ 0.75K |
|              |              | 4.0%          |               | 1.5K ~ 3.7K |
|              |              | 3.0%          |               | 5.5K        |

**Settin** Torque boost

- ◆ If 01-10=6% and 01-04=220V, and when output frequency of the inverter is 0.2Hz, the output voltage is:

$$P.19 \times \left( \frac{100\% - P.0}{P.3} \times f + P.0 \right) = 220V \times \left( \frac{100\% - 6\%}{50Hz} \times 0.2Hz + 6\% \right) = 14.03V$$

- ◆ If RT is “on,” “the second torque boost” on 01-24 is valid (Note 2).

Note: 1. If the set value of 01-10 is too high, it will activate current inverter protection or the activation will be impeded.  
 2. Please refer to Section 5.2.10 for the second torque boost.  
 3. RT mentioned in this section is the function name of the “multi-function digital input terminal”. Please refer to 03-00~03-06, 03-09 for function selection and purposes of the multi-function digital input terminal. For related wiring, please refer to Section 3.7.

### 5.2.5 Starting frequency

- ◆ When the motor starts up, the instantaneous output frequency of the inverter is called “starting frequency”.

| Parameter     | Name               | Factory Value | Setting Range | Content |
|---------------|--------------------|---------------|---------------|---------|
| 01-11<br>P.13 | Starting frequency | 0.50Hz        | 0 ~ 60.00Hz   | ---     |

**Settin** Starting frequency

- ◆ If the target frequency of the inverter is lower than the setting value of 01-11, the motor will not run. When the signal of the motor starts, the output frequency will go up from the value of 01-11.

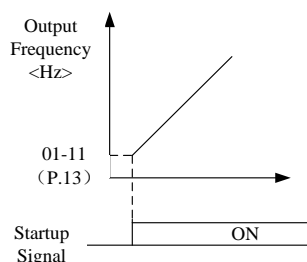

### 5.2.6 Load pattern selection V/F

- ◆ Optimal output characteristics for application or load characteristics can be selected when in V/F control.

| Parameter     | Name                   | Factory Value | Setting Range | Content  |
|---------------|------------------------|---------------|---------------|--|
| 01-12<br>P.14 | Load pattern selection | 0             | 0             | Applicable to constant torque loads (convey belt, etc.)    |
|               |                        |               | 1             | Applicable to variable torque loads (fans and pumps, etc.) |
|               |                        |               | 2、3           | Applicable to ascending / descending loads                 |
|               |                        |               | 4             | Multipoint VF curve  |
|               |                        |               | 5 ~ 13        | Special two-point VF curve                                 |

Setting Load pattern selection

- ◆ When 01-12 = 4, suppose that 01-04=220V, 01-26=5Hz, 01-27=10%, when the inverter is running at 5Hz, the output voltage equals to 01-04×01-27 = 220V×10% = 22V.
- ◆ If RT is “on”, 01-24 “the second torque boost” is valid.

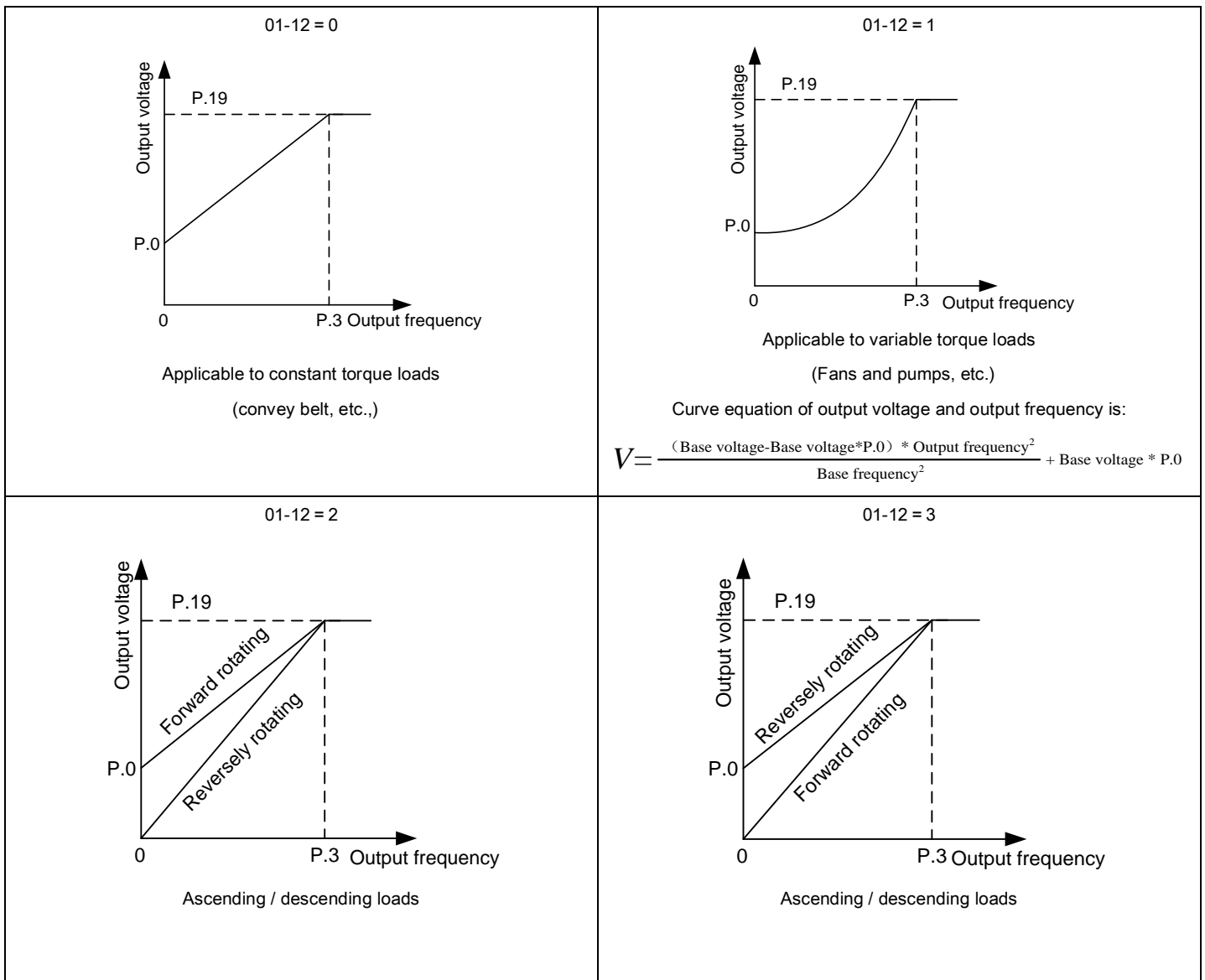

Basic parameter group 01

01-12 = 4

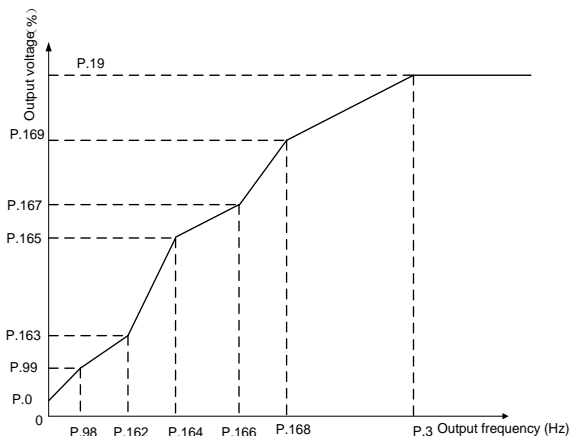

Whether it is high startup torque or descending torque, they are due to the set values (Note 1).

01-12=5

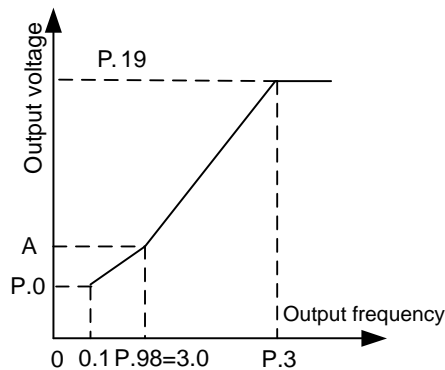

When P.14 = 5, the value of A is 7.1% (Note 2).

01-12 = 6, 7, 8

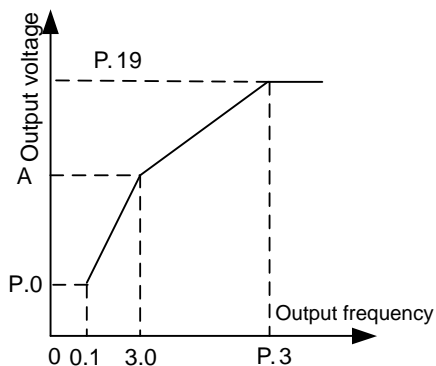

When 01-12=6, the value of A is 8.7%. When 01-12=7, the value of A is 10.4%. When 01-12=8, the value of A is 12.0%. (Note 2)

01-12 = 9, 10

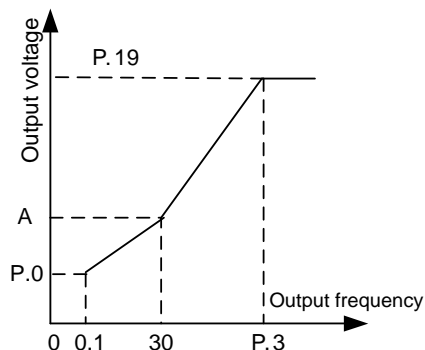

When P.14=9, the value of A is 20.0%. When P.14=10, the value of A is 25.0%. (Note 2)

01-12 = 11, 12, 13

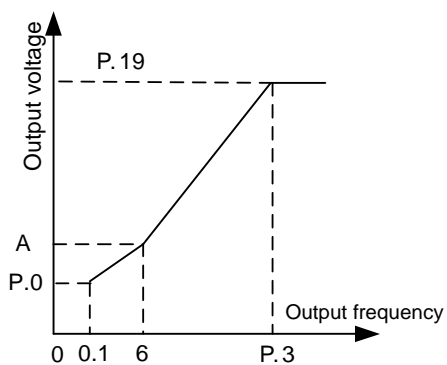

When 01-12 = 11, the value of A is 9.3%. When 01-12 = 12, the value of A is 12.7%. When 01-12 = 13, the value of A is 16.1%. (Note 2)

Note: 1. Referring to the diagrams above, set 01-26 and 01-27, if one point is needed. Set 01-26, 01-27, 01-28 and 01-29 if two points are needed. 01-26, 01-27, 01-28, 01-29, 01-30 and 01-31 if three points are needed.

2. If you set 01-12 between 5 and 13, the curve will be invalid when 01-10 is larger than the point A, where point A equals to 01-10.

## 5.2.7 JOG operation

- ◆ The frequency and acceleration/deceleration time for JOG operation can be set. JOG operation can be used for conveyor positioning, test run, etc.

| Parameter     | Name                                   | Factory Value | Setting Range               | Content             |
|---------------|--|---------------|-----------------------------|---------------------|
| 01-13<br>P.15 | JOG frequency                          | 5.00Hz        | 0 ~ 650.00Hz                | ---                 |
| 01-14<br>P.16 | JOG acceleration/<br>deceleration time | 0.50s         | 0 ~ 360.00s/<br>0 ~ 3600.0s | 01-08=0/<br>01-08=1 |

### Setting JOG operation

- ◆ In JOG mode, the output frequency is the set value of 01-13, and the acceleration / deceleration time is the set value of 01-14.

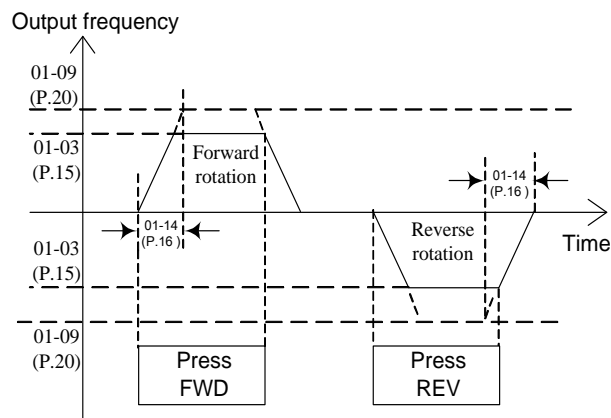

Note: Please refer to Section 4.3.3 for how to enter the JOG mode.

## 5.2.8 Output frequency filter time

- ◆ When Output frequency filter time is set, the inverter can filter out the output frequency to reduce machine vibration upon high-frequency and low-frequency is switched.

| Parameter     | Name                            | Factory Value | Setting Range | Content |
|---------------|---------------------------------|---------------|---------------|---------|
| 01-15<br>P.28 | Output frequency filter<br>time | 0             | 0 ~ 31        | ---     |

### Setting Output frequency filter time

- ◆ The bigger the output frequency filter time is, the better the filtering effect is. But the corresponding response delay will also increase.
- ◆ When the value is 0, the filter function is invalid.

### 5.2.9 Frequency jump

- ◆ When it is desired to avoid resonance attributable to the natural frequency of a mechanical system, these parameters allow resonant frequencies to be jumped.

| Parameter     | Name              | Factory Value | Setting Range | Content  |
|---------------|-------------------|---------------|---------------|----------|
| 01-16<br>P.91 | Frequency jump 1A | 99999         | 0 ~ 650.00Hz  | ---      |
|               |                   |               | 99999         | Invalid. |
| 01-17<br>P.92 | Frequency jump 1B | 99999         | 0 ~ 650.00Hz  | ---      |
|               |                   |               | 99999         | Invalid. |
| 01-18<br>P.93 | Frequency jump 2A | 99999         | 0 ~ 650.00Hz  | ---      |
|               |                   |               | 99999         | Invalid. |
| 01-19<br>P.94 | Frequency jump 2B | 99999         | 0 ~ 650.00Hz  | ---      |
|               |                   |               | 99999         | Invalid. |
| 01-20<br>P.95 | Frequency jump 3A | 99999         | 0 ~ 650.00Hz  | ---      |
|               |                   |               | 99999         | Invalid. |
| 01-21<br>P.96 | Frequency jump 3B | 99999         | 0 ~ 650.00Hz  | ---      |
|               |                   |               | 99999         | Invalid. |

#### Setting Frequency jump

- ◆ To avoid system's mechanical resonance frequency when running the motor, the inverter provides three sets of jump frequencies, namely, 01-16 and 01-17 (the first set), 01-18 and 01-19 (the second set), 01-20 and 01-21 (the third set).

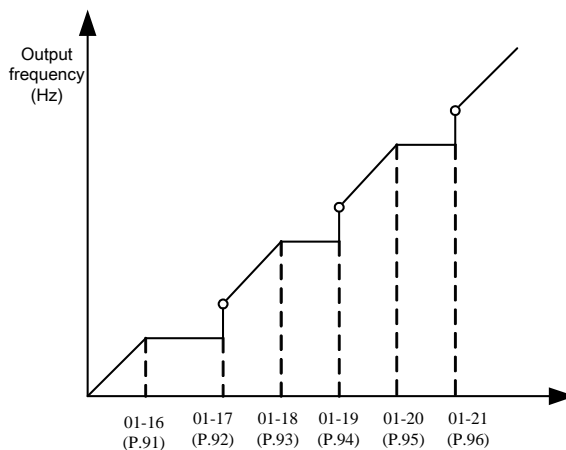

- ◆ For example: assuming 01-16=45 and 01-17=50;  
 If the target frequency  $\leq 45\text{Hz}$ , then the steady output frequency = the target frequency.  
 If  $45\text{Hz} \leq \text{target frequency} < 50\text{Hz}$ , then the steady output frequency = 45Hz.  
 If the target frequency  $\geq 50\text{Hz}$ , then the steady output frequency = the target frequency.

Note: 1. During the acceleration / deceleration period, the output frequency of the inverter will still pass through the jump frequency.  
 2. When 01-16=99999 or 01-17=99999, the first set of frequency jump is invalid.  
 When 01-18=99999 or 01-19=99999, the second set of frequency jump is invalid.  
 When 01-20=99999 or 01-21=99999, the third set of frequency jump is invalid.

## 5.2.10 The second function

- ◆ It is appropriate for the parameters when the RT signal is ON.

| Parameter     | Name                         | Factory Value | Setting Range               | Content             |
|---------------|------------------------------|---------------|-----------------------------|---------------------|
| 01-22<br>P.44 | The second acceleration time | 99999         | 0 ~ 360.00s/<br>0 ~ 3600.0s | 01-08=0/<br>01-08=1 |
|               |                              |               | 99999                       | Not selected.       |
| 01-23<br>P.45 | The second deceleration time | 99999         | 0 ~ 360.00s/<br>0 ~ 3600.0s | 01-08=0/<br>01-08=1 |
|               |                              |               | 99999                       | Not selected.       |
| 01-24<br>P.46 | The second torque boost      | 99999         | 0 ~ 30.0%                   | ---                 |
|               |                              |               | 99999                       | Not selected.       |
| 01-25<br>P.47 | The second base frequency    | 99999         | 0 ~ 650.00Hz                | ---                 |
|               |                              |               | 99999                       | Not selected.       |

 The second function

- ◆ When 01-08=0, minimum acceleration / deceleration time (01-22, 01-23) increment is 0.01s.
- ◆ When 01-08=1, minimum acceleration / deceleration time (01-22, 01-23) increment is 0.1s.
- ◆ When RT is “on”, the second function is valid. For the operation characteristics of the motor, please refer to the following second function setting.

If 01-22≠99999 and 01-23=99999, when RT is “on”, the acceleration /deceleration time is the “set value of 01-22”.

If 01-22≠99999 and 01-24=99999, when RT is “on”, the torque boost is the “set value of 01-10”.

If 01-22≠99999 and 01-24≠99999, when RT is “on”, the torque boost is the “set value of 01-24”.

If 01-22≠99999 and 01-25=99999, when RT is “on”, the base frequency is the “set value of 01-03”.

If 01-22≠99999 and 01-25≠99999, when RT is “on”, the base frequency is the “set value of 01-25”.

Note: RT motioned here is the function name of “multi-function digital input terminal”. Please refer to 03-00, 03-01, 03-03 and 03-04, for the function selection of multi-function digital input terminal.

## 5.2.11 Middle frequency, output voltage of middle frequency V/F

- ◆ Parameters can be set when using a special motor, especially adjusting the motor torque.

| Parameter      | Name                                 | Factory Value | Setting Range | Content       |
|----------------|--------------------------------------|---------------|---------------|---------------|
| 01-26<br>P.98  | Middle frequency 1                   | 3.00Hz        | 0 ~ 650.00Hz  | ---           |
| 01-27<br>P.99  | Output voltage 1 of middle frequency | 10.0%         | 0 ~ 100.0%    | ---           |
| 01-28<br>P.162 | Middle frequency 2                   | 99999         | 0 ~ 650.00Hz  | ---           |
|                |                                      |               | 99999         | Not selected. |
| 01-29<br>P.163 | Output voltage 2 of middle frequency | 0.0%          | 0 ~ 100.0%    | ---           |
| 01-30<br>P.164 | Middle frequency 3                   | 99999         | 0 ~ 650.00Hz  | ---           |
|                |                                      |               | 99999         | Not selected. |
| 01-31<br>P.165 | Output voltage 3 of middle frequency | 0.0%          | 0 ~ 100.0%    | ---           |
| 01-32<br>P.166 | Middle frequency 4                   | 99999         | 0 ~ 650.00Hz  | ---           |
|                |                                      |               | 99999         | Not selected. |
| 01-33<br>P.167 | Output voltage 4 of middle frequency | 0.0%          | 0 ~ 100.0%    | ---           |
| 01-34<br>P.168 | Middle frequency 5                   | 99999         | 0 ~ 650.00Hz  | ---           |
|                |                                      |               | 99999         | Not selected. |
| 01-35<br>P.169 | Output voltage 5 of middle frequency | 0.0%          | 0 ~ 100.0%    | ---           |

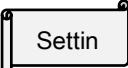
 Middle frequency, output voltage of middle frequency

- ◆ Please refer to the description on 01-12=4 in Section 5.2.6 Load pattern selection.

## 5.2.12 S pattern time

- ◆ It is used to set the acceleration time of S pattern acceleration/deceleration.

| Parameter      | Name  | Factory Value | Setting Range             | Content             |
|----------------|---|---------------|---------------------------|---------------------|
| 01-36<br>P.255 | S pattern time at the beginning of acceleration | 0.20s         | 0 ~ 25.00s/<br>0 ~ 250.0s | 01-08=0/<br>01-08=1 |
| 01-37<br>P.256 | S pattern time at the end of acceleration       | 99999         | 0 ~ 25.00s/<br>0 ~ 250.0s | 01-08=0/<br>01-08=1 |
|                |   |               | 99999                     | Not selected.       |
| 01-38<br>P.257 | S pattern time at the beginning of deceleration | 99999         | 0 ~ 25.00s/<br>0 ~ 250.0s | 01-08=0/<br>01-08=1 |
|                |   |               | 99999                     | Not selected.       |
| 01-39<br>P.258 | S pattern time at the end of deceleration       | 99999         | 0 ~ 25.00s/<br>0 ~ 250.0s | 01-08=0/<br>01-08=1 |
|                |   |               | 99999                     | Not selected.       |

Settin

 S pattern time

- ◆ When 01-05 = 3, "S pattern acceleration /deceleration curve 3".

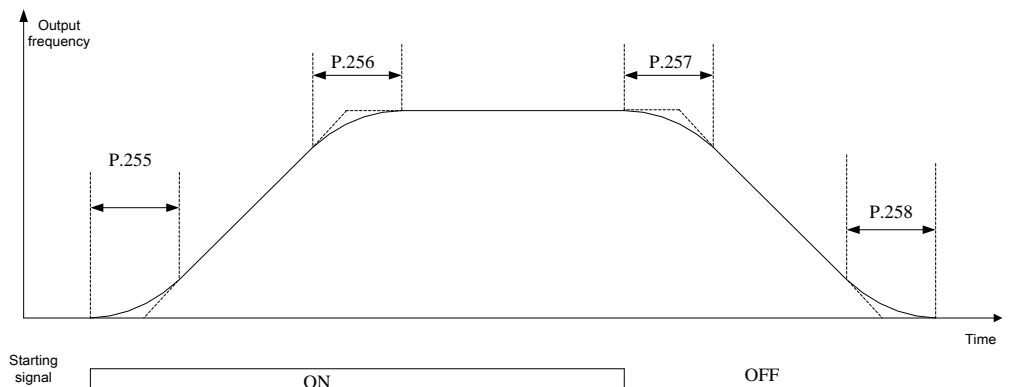

- 1) The parameters 01-36, 01-37, 01-38 and 01-39 are used to start the inverter gradually without impact. And varying degrees of S pattern acceleration/deceleration curve are adjusted by the values. When the S pattern acceleration/deceleration curve is started, the inverter will accelerate/decelerate with different speed according to the primary acceleration/deceleration time.
- 2) When S pattern acceleration/deceleration curve 3 is selected, the acceleration/ deceleration time will be longer, as follows.
- 3) When the selected acceleration time (01-06 or 01-22)  $\geq$  01-36 and 01-37, the actual acceleration time is as follows:  
The actual acceleration time = the selected acceleration time + (01-36 + 01-37) / 2
- 4) When the selected deceleration time (01-07 or 01-23)  $\geq$  01-38 and 01-39, the actual deceleration time is as follows:  
The actual deceleration time = the selected deceleration time + (01-38 + 01-39) / 2

Example: when the parameters are initial value (60 Hz system), the actual acceleration time from 0Hz to 60Hz in accordance with S pattern acceleration/deceleration curve 3 is as follows:

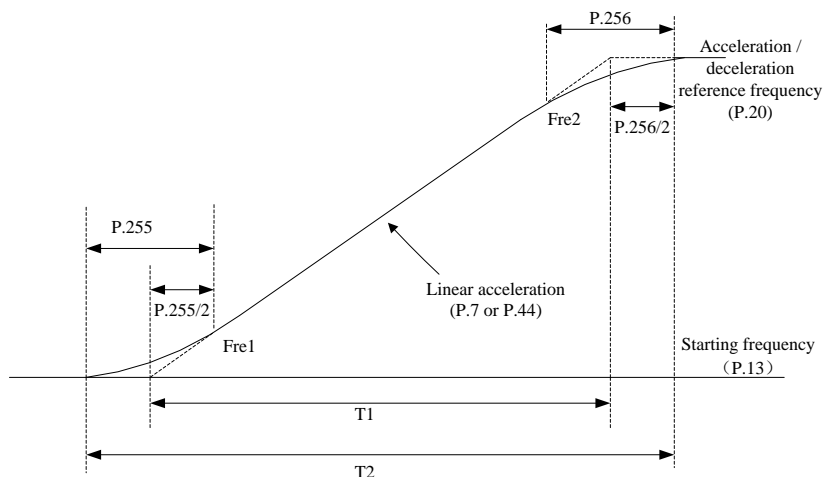

The acceleration time being set  $T1 = (01-09 - 01-11) * 01-06 / 01-09$

The actual acceleration time  $T2 = T1 + (01-36 + 01-37) * (01-09 - 01-11) / 2 / 01-09$

So  $T1 = (60 - 0.5) * 5 / 60 = 4.96s$  (the actual acceleration time of linear acceleration)

The actual acceleration time  $T2 = 4.96 + (0.2 + 0.2) * (60 - 0.5) / 2 / 60 = 5.16s$

Note: All calculations of acceleration/deceleration time are based on 01-09.

## 5.3 Analog input and output parameter group 02

| Group | Parameter Number | Name   | Setting Range  | Factory Value     | Page |
|-------|------------------|--|--|-------------------|------|
| 02-06 | P.185            | Proportion linkage gain  | 0 ~ 100%   | 0%                | 76   |
| 02-07 | P.240            | Auxiliary frequency  | 0: No auxiliary frequency function is available.   | 0                 | 77   |
|       |                  |  | 2: operation frequency = basic frequency + auxiliary frequency (given by the 3-5 terminal)   |                   |      |
|       |                  |  | 4: operation frequency = basic frequency - auxiliary frequency (given by the 3-5 terminal)   |                   |      |
|       |                  |  | 6: Operation frequency = 3-5 terminal linkage signal given as a percentage   |                   |      |
| 02-10 | P.60             | 3-5 filter time  | 0 ~ 2000ms   | 31ms              | 78   |
| 02-20 | P.17             | 3-5 signal selection   | 0: The effective range of signal sampling is 4~20mA.   | 1                 | 78   |
|       |                  |  | 1: The effective range of signal sampling is 0 ~ 10V.  |                   |      |
|       |                  |  | 2: The effective range of signal sampling is 0 ~ 5V.   |                   |      |
| 02-21 | P.39             | The maximum operation frequency of terminal 3-5                                    | 50Hz system: 1.00 ~ 650.00Hz   | 50.00Hz           | 78   |
|       |                  |  | 60Hz system: 1.00 ~ 650.00Hz   | 60.00Hz           |      |
| 02-24 | P.184            | 3-5 disconnection selection  | 0: No disconnection selection is available.  | 0                 | 78   |
|       |                  |  | 1: Decelerate to 0Hz, the digital output terminal will set off the alarm   |                   |      |
|       |                  |  | 2: The inverter will stop immediately, and the panel will display the "AER" alarm.   |                   |      |
|       |                  |  | 3: The inverter will run continuously according to the frequency reference before the disconnection. The digital output terminal will set off the alarm. |                   |      |
| 02-25 | P.198            | The minimum input current/ voltage of terminal 3-5                                 | 0 ~ 20.00 mA /V  | 0.00V             | 78   |
| 02-26 | P.199            | The maximum input current/ voltage of terminal 3-5                                 | 0 ~ 20.00 mA/ V  | 10.00V            | 78   |
| 02-27 | P.196            | The percentage corresponding to the minimum input current/ voltage of terminal 3-5 | 0% ~ 100.0%  | 0.0%              | 78   |
| 02-28 | P.197            | The percentage corresponding to the maximum input current/ voltage of terminal 3-5 | 0% ~ 100.0%  | 100.0%            | 78   |
| 02-52 | P.56             | Output current display the datum   | 0~500.00A  | According to type | 83   |
| 02-61 | P.141            | 3-5 current/voltage input corresponding to the percentage of plus or minus         | 0~11   | 0                 | 78   |

### 5.3.1 Proportion linkage gain

- ◆ The function is used to multiply the setting frequency by the external analog input terminal. When many inverters run proportionally, the reference frequency from the master inverter to the slave inverter can be fine tuned effectively with the function.

| Parameter      | Name                    | Factory Value | Setting Range | Content |
|----------------|-------------------------|---------------|---------------|---------|
| 02-06<br>P.185 | Proportion linkage gain | 0%            | 0 ~ 100%      | ---     |

**Setting** Proportion linkage gain

- ◆ When the operation frequency is smaller than 01-01, the operation frequency will be equal to the minimum limited frequency 01-01. When the operation frequency is larger than 01-00, the operation frequency will be equal to the maximum limited frequency 01-00.
- ◆ After multiplying the setting frequency by the set value of 02-06, then addition and subtraction can be performed as the following shows:

For example: When the setting frequency is 50Hz, 02-06=50% and the external analog input signal is 0~10V.

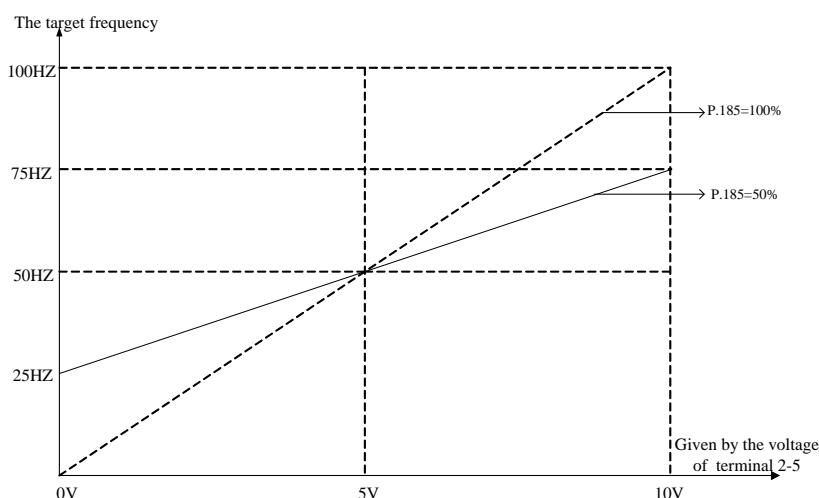

In the above figure, when 0V is given, the target frequency is  $50\text{Hz} - (50\text{Hz} \times 50\%) = 25\text{Hz}$ ;

when 5V is given, the target frequency is  $50\text{Hz} - (50\text{Hz} \times 0\%) = 50\text{Hz}$ ;

when 10V is given, the target frequency is  $50\text{Hz} + (50\text{Hz} \times 50\%) = 75\text{Hz}$ .

Note: 1. Please refer to the instruction of 02-07(P.240) for the proportion linkage signal input.  
 2. When the analog current/voltage signal of external terminal 3-5 is taken as the proportion linkage input signal, please refer to the parameter 02-20. For the frequency range setting of external analog signal, please refer to the parameters 02-21.

### 5.3.2 Auxiliary frequency

- ◆ It can flexibly implement fine tuning of frequency and frequency synthesis to meet different control requirements of different scenarios.

| Parameter      | Name                | Factory Value | Setting Range | Content   |
|----------------|---------------------|---------------|---------------|---|
| 02-07<br>P.240 | Auxiliary frequency | 0             | 0             | No auxiliary frequency function is available.   |
|                |                     |               | 2             | Operation frequency = basic frequency + auxiliary frequency (given by the 3-5 terminal) |
|                |                     |               | 4             | Operation frequency = basic frequency - auxiliary frequency (given by the 3-5 terminal) |
|                |                     |               | 6             | Operation frequency = 3-5 Terminal linkage signal given as a percentage                 |

 Auxiliary frequency

- ◆ When the operation frequency is smaller than 01-01, the operation frequency will be equal to the minimum limited frequency 01-01. When the operation frequency is larger than 01-00, the operation frequency will be equal to the maximum limited frequency 01-00.

Note: 1. The basic frequency is set by operation penal which is the target frequency reference source, communication or multi-speed combination.  
 2. Please refer to the instruction of 02-06 for the proportion linkage signal input.  
 3. When the analog current/voltage signal of external terminal 3-5 is taken as the proportion linkage input signal, please refer to the parameter 02-20. For the frequency range setting of external analog signal, please refer to the parameters 02-21.

## 5.3.3 Selection and handling of input terminal 3-5

- ◆ Selects the signal specifications, frequency compensation function, etc, via input terminal 3-5.

| Parameter      | Name  | Factory Value | Setting Range   | Content   |
|----------------|---|---------------|-----------------|---|
| 02-10<br>P.60  | 3~5 filter time   | 31ms          | 0 ~ 2000ms      | ---   |
| 02-20<br>P.17  | 3-5 signal selection  | 1             | 0               | The effective range of signal sampling is 4~20mA.   |
|                |   |               | 1               | The effective range of signal sampling is 0 ~ 10V.  |
|                |   |               | 2               | The effective range of signal sampling is 0 ~ 5V.   |
| 02-21<br>P.39  | The maximum operation frequency of terminal 3-5                                   | 50.00Hz       | 1.00 ~ 650.00Hz | 50Hz system (00-24=1)   |
|                |   | 60.00Hz       |                 | 60Hz system (00-24=0)   |
| 02-24<br>P.184 | 3-5 disconnection selection   | 0             | 0               | No disconnection selection is available.  |
|                |   |               | 1               | Decelerate to 0Hz, the digital output terminal will set off the alarm   |
|                |   |               | 2               | The inverter will stop immediately, and the panel will display the "AErr" alarm.  |
|                |   |               | 3               | The inverter will run continuously according to the frequency reference before the disconnection. The digital output terminal will set off the alarm. |
| 02-25<br>P.198 | The minimum input current/voltage of terminal 3-5                                 | 0.00V         | 0 ~ 20.00mA/V   | ---   |
| 02-26<br>P.199 | The maximum input current/voltage of terminal 3-5                                 | 10.00V        | 0 ~ 20.00mA/V   | ---   |
| 02-27<br>P.196 | The percentage corresponding to the minimum input current/voltage of terminal 3-5 | 0.0%          | 0% ~ 100.0%     | ---   |
| 02-28<br>P.197 | The percentage corresponding to the maximum input current/voltage of terminal 3-5 | 100.0%        | 0% ~ 100.0%     | ---   |
| 02-61<br>P.141 | 3-5 current/voltage input corresponding to the percentage of plus or minus        | 0             | 0~11            | ---   |

 3-5 signal selection, 3-5 maximum operation frequency

- ◆ The setting value of 02-21 is the target frequency value of the inverter when the input signal of terminal 3-5 is 20mA ( 5V/10V ) .

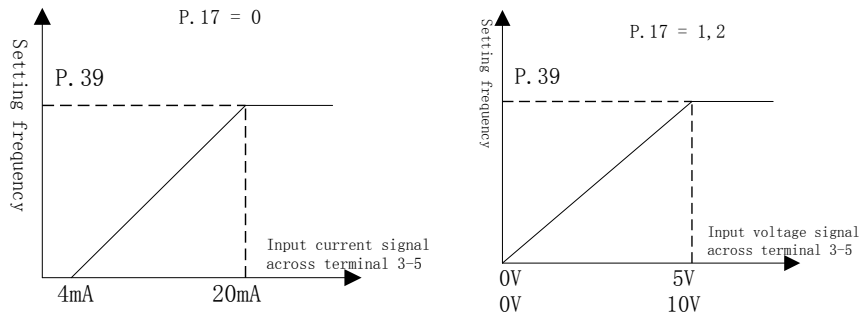

**Settin** Handling of input terminal 3-5

- ◆ The parameters above define the relationship between analog input voltage and the setting value what analog input represents. When the analog input voltage exceeds the maximum or minimum range of the setting value, the excess will be computed as the maximum or minimum input.
- ◆ There are two setting order when the maximum or minimum percentage is set:
  - 1 ) If the users hope to adjust the analog input magnitude to correspond to a certain proportion relationship, the analog input need to be adjusted before setting the corresponding proportion parameters. Now the inverter will compute automatically without setting the voltage parameters. Please refer to the example 1.1.
  - 2 ) If the users skip adjusting analog input to set the proportion relationship, the proportion parameter should be set before setting the voltage parameters. Please refer to the example 1.2.

Example 1.1: Adjust the analog input voltage to the minimum value A and set the parameter 02-25. Then adjust the input voltage to the maximum value B and set the parameter 02-26. The figure is shown as follows:

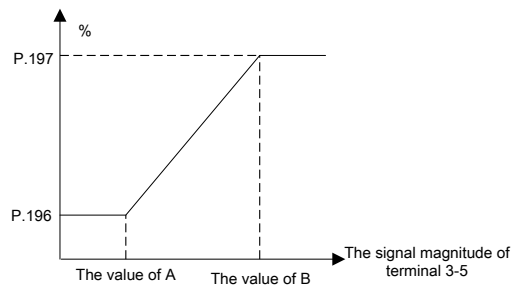

Example 1.2: Set the value of 02-27 and 02-28, then set 02-25 and 02-26. The figure is shown as follows:

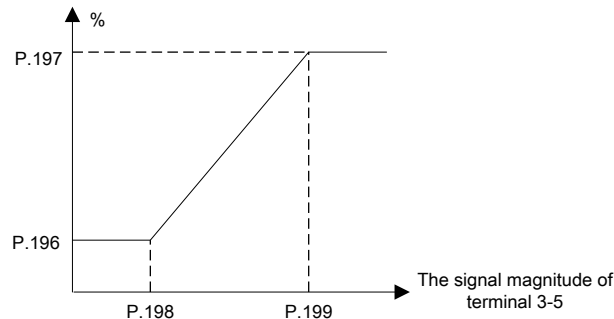

If choose for external simulation for frequency, according to the above to calculate the proportion of times the 02-21 for the actual frequency of the input value (3-5 current/voltage input corresponding percentage choice of 02-61 = 0).

**Settin** 3-5 Current/voltage input corresponding to the percentage of plus or minus

- ◆ parameters P.141 set in a way, a total of two, it's the meaning of each said as follows:

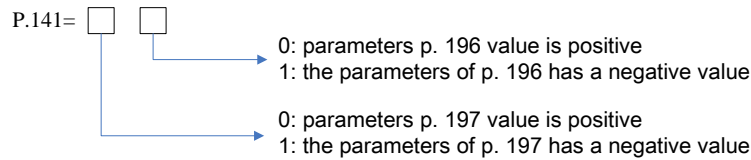

If a given current/voltage is negative, the percentage of the input frequency converter according to the given operation direction reverse operation.

- ✓ 3-5Terminal of some examples

Example 1: This example is the most commonly used method of adjustment. It is used when the inverter is in the "external mode", "combined mode 2" or "combined mode 4", and the frequency are set by terminal 3-5.

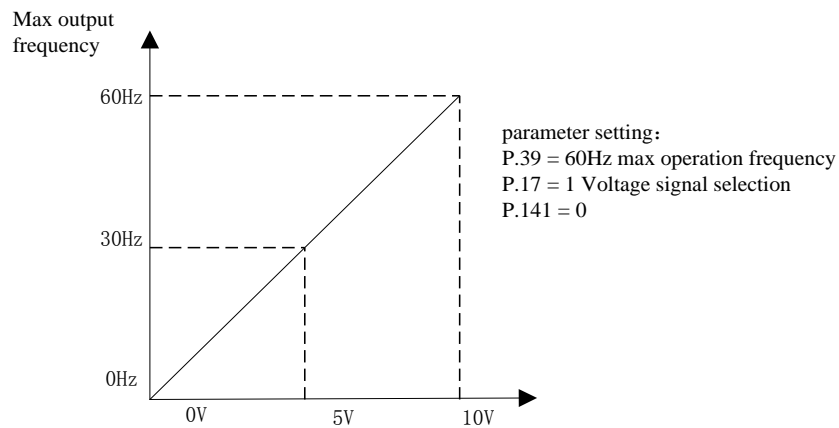

Example 2: This example is used by the industry for operating the ac motor drive. The goal is to have the set potentiometer equals to 10Hz when rotating to the far left. In other words, when activating, the lowest output of the ac motor drive has to be 10Hz. Other frequencies can be adjusted by the industry freely.

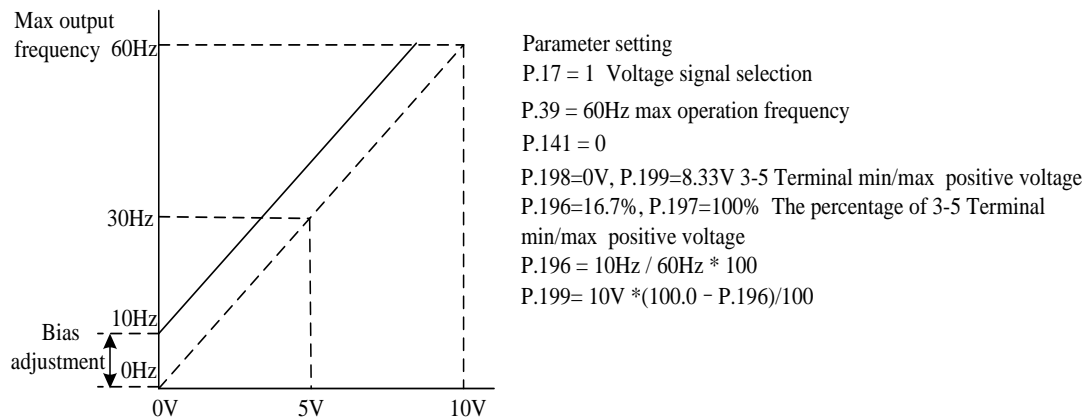

Example 3: This example is also frequently used by the industry. The comprehensive usage for all domain of the potentiometer setup elevates the flexibility.

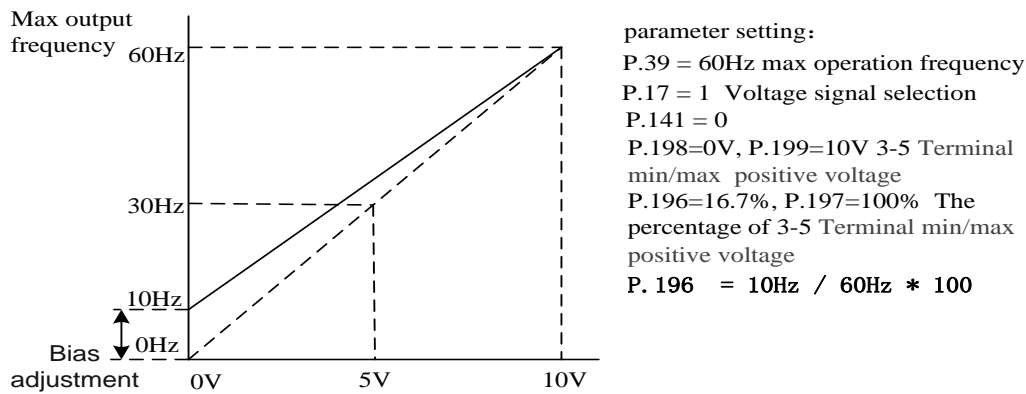

Example 4: This example uses 0~5V to set the frequency.

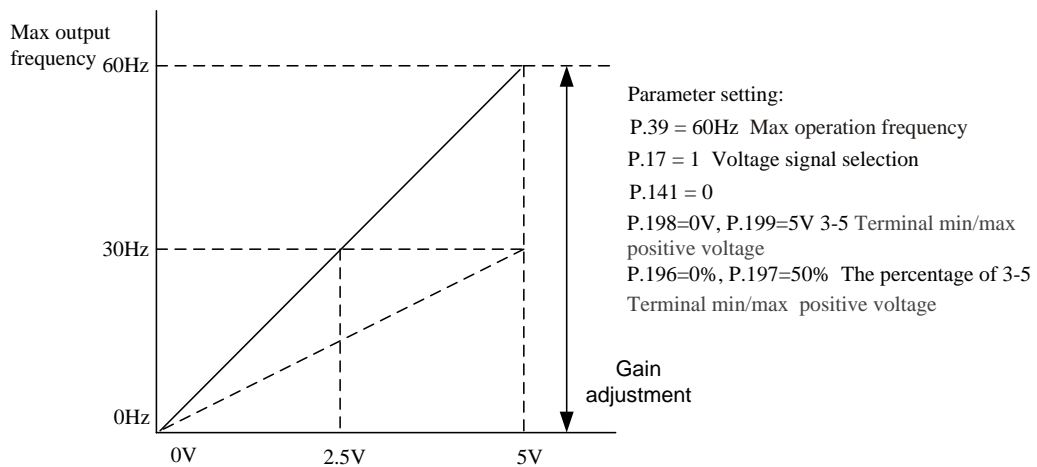

Example 5: This example is recommended to avoid using a signal that is less than 1V to set up the operation frequency of the AC motor drive under an unfavorable application environment, so that the anti-noise interference effect will be better.

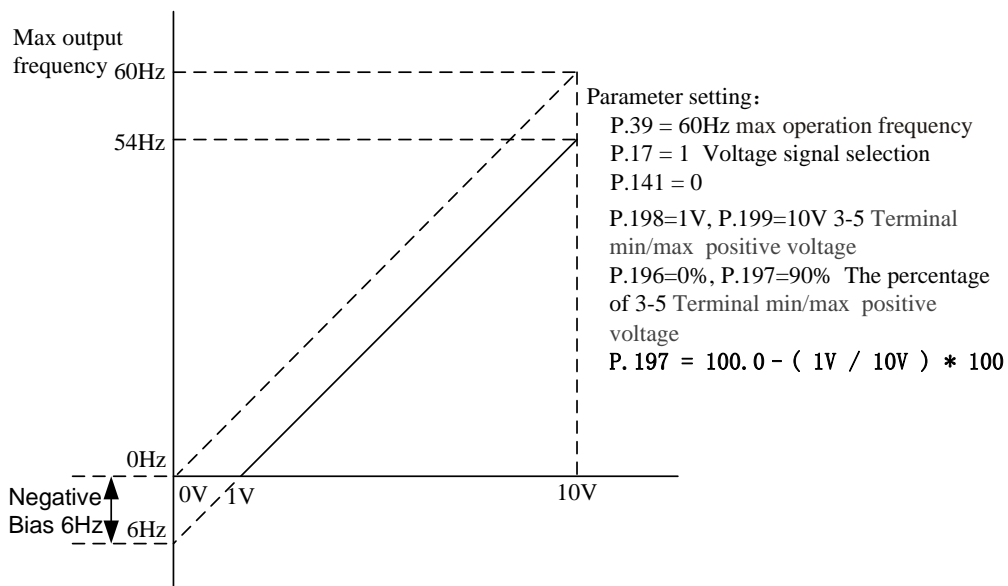

Example 6: This example is an extension of Example 6. The wide application of this example offers the users good flexibility.

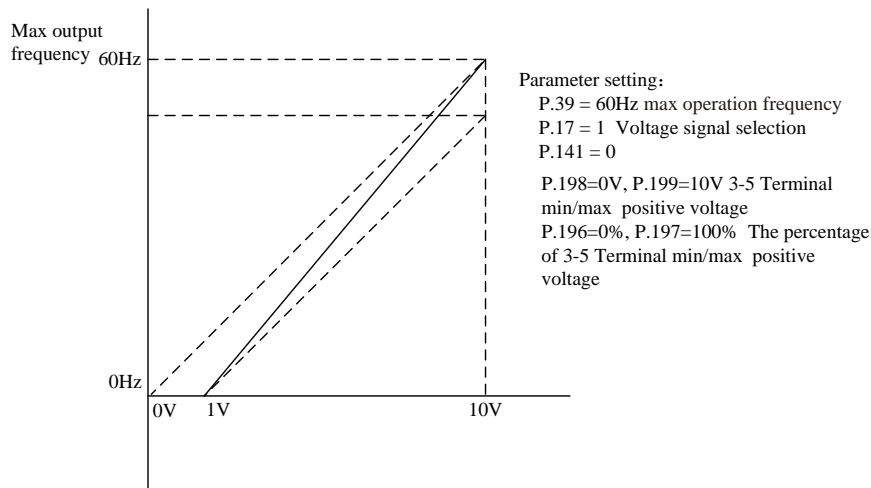

Example 7: This example is an application of negative slop setup. The industry often uses sensors for pressure, temperature or flow control. Some of the sensors output a 10V signal at high voltage or high flow. This signal acts as a reference for the AC motor drive to decelerate or to stop. The setup presented in Example 8 can satisfy this type of application.

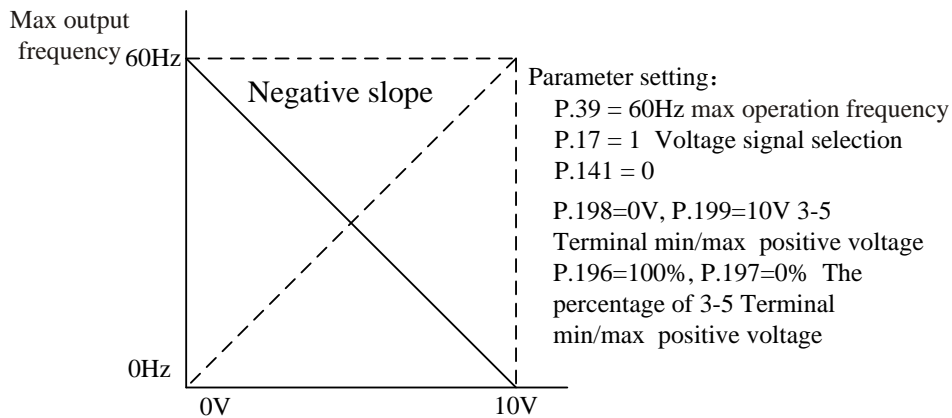

Example 8: This example integrates all the application of potentiometer. Together with the application of forward and reverse rotation, it fits in the system easily for assorted complicated application.

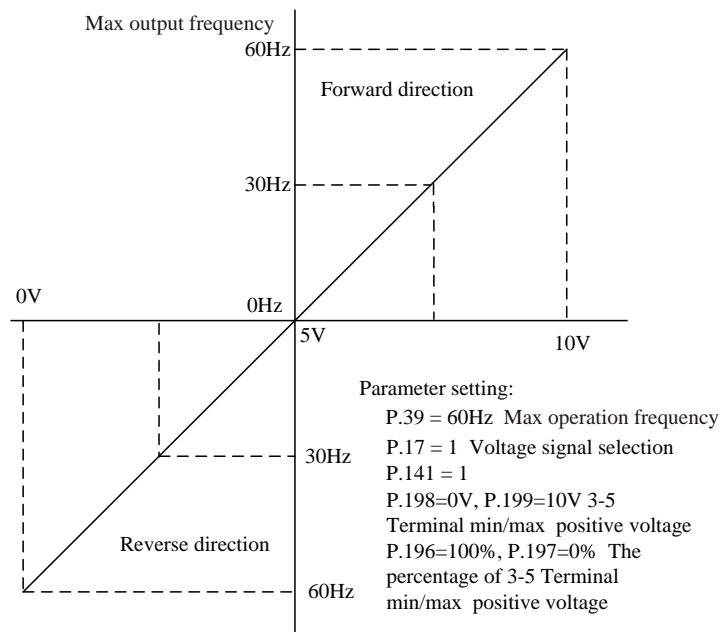

Note: 1. In the mode of "external" or "mixed mode 2" or "mixed mode 4", if the AU "on" and 02-01 = 1, the target frequency of frequency converter, is decided by 3-5 terminal signal.

2. In the mode of "external" or "mixed mode 2" or "mixed mode 4", the AU and RH, RM, RL, or any one of REX to "on" at the same time, the goal of the inverter frequency with multistage speed is preferred.

3. This paragraph mentioned RH, RM, RL, REX, AU is the function of "multi-function digital input terminals" name. Selection and function, the function of the multi-function digital input terminals refer to 03-03, 03-04, 03-00, 03-01; Related wiring, please refer to section 3.7.

4. 3-5 analog terminals can be either a given voltage, can also be current is given, by P. 17 and AVI - ACI switch function.

◆ 3-5 disconnection selection

- 1) When 02-24 = 0, the inverter will decelerate to 0Hz when disconnected. After reconnecting the inverter, the inverter will accelerate to the corresponding frequency.
- 2) When 02-24 = 1, after the break, the panel displays "AErr" alert, frequency converter to slow down to 0 Hz, multi-function digital output terminals have alarm output at the same time; Back in line after the all-clear, the corresponding frequency inverter speed to the current.
- 3) When 02-24=2, the panel will display the "AErr" alarm when disconnected. The inverter will stop immediately. Reset to clear the alarm.
- 4) When 02-24=3, the inverter will run continuously according to the frequency command before the disconnection. The multi-function output terminal will set off the alarm. Reconnect to clear the alarm.

Note: Please refer to 03-10, 03-12 and 03-13 for the function selection of the multi-function digital output terminal. For wiring, please refer to Section 3.7.

◆ Input current/voltage of terminal 3-5

3-5 terminals cannot give negative voltage and choosing current minimum input is 4mA.

Note: Operating the 3-5 terminal function mentioned above, you must flip the switch AVI-ACI to corresponding position at first and make sure it matches the setting value of parameter 02-20.

### 5.3.4 Output current according to the benchmark

◆ According to the benchmark for setting the output current.

| Parameter     | Name   | Factory Value | Setting Range | Content |
|---------------|--|---------------|---------------|---------|
| 02-52<br>P.56 | Current display the output of the simulation benchmark | Note          | 0 ~ 500.00A   | ---     |

 According to the benchmark

◆ Used to display output current.

Note: parameters 02-52 factory value determined by the model.

## 5.4 Digital input/output parameter group03

| Group   | Parameter Number | Name                   | Setting Range  | Factory Value | Page |
|---|------------------|------------------------|--|---------------|------|
| 03-00   | P.83             | STF function selection | 0: STF(the inverter runs forward)  | 0             | 87   |
|   |                  |                        | 1: STR(the inverter runs reverse)  |               |      |
|   |                  |                        | 2: RL(Multi-speed low speed)   |               |      |
|   |                  |                        | 3: RM(Multi-speed medium speed)  |               |      |
|   |                  |                        | 4: RH(multi-speed high speed)  |               |      |
|   |                  |                        | 5:Reserved   |               |      |
|   |                  |                        | 6: The external thermal relay operation  |               |      |
|   |                  |                        | 7: MRS(the instantaneous stopping of the inverter output)  |               |      |
|   |                  |                        | 8: RT(the inverter second function)  |               |      |
|   |                  |                        | 9: EXT(external JOG)   |               |      |
|   |                  |                        | 10: STF+EXJ  |               |      |
|   |                  |                        | 11: STR+EXJ  |               |      |
|   |                  |                        | 12: STF+RT   |               |      |
|   |                  |                        | 13: STR+RT   |               |      |
|   |                  |                        | 14: STF+RL   |               |      |
|   |                  |                        | 15: STR+RL   |               |      |
|   |                  |                        | 16: STF+RM   |               |      |
|   |                  |                        | 17: STR+RM   |               |      |
|   |                  |                        | 18: STF+RH   |               |      |
|   |                  |                        | 19: STR+RH   |               |      |
|   |                  |                        | 20: STF+RL+RM  |               |      |
|   |                  |                        | 21: STR+RL+RM  |               |      |
|   |                  |                        | 22: STF+RT+RL  |               |      |
|   |                  |                        | 23: STR+RT+RL  |               |      |
|   |                  |                        | 24: STF+RT+RM  |               |      |
|   |                  |                        | 25: STR+RT+RM  |               |      |
|   |                  |                        | 26: STF+RT+RL+RM   |               |      |
|   |                  |                        | 27: STR+RT+RL+RM   |               |      |
|   |                  |                        | 28: RUN(the inverter runs forward)   |               |      |
|   |                  |                        | 29: STF/STR(it is used with RUN, when STF/STR is "on", the inverter runs reverse ; when STF/STR is "off", the inverter runs forward) |               |      |
|   |                  |                        | 30: RES(external reset function)   |               |      |
|   |                  |                        | 31: STOP(it can be used as a three-wire mode with the RUN signal or the STF-STR terminal)  |               |      |
|   |                  |                        | 32: REX(multi-speed set (16 levels))   |               |      |
|   |                  |                        | 33: PO(in "external mode", programmed operation mode is chosen)  |               |      |
| 34: RES_E (external reset become valid only when the alarm goes off.) |                  |                        |  |               |      |

| Group                           | Parameter Number | Name                   | Setting Range  | Factory Value | Page |
|---------------------------------|------------------|------------------------|--|---------------|------|
| 03-00                           | P.83             | STF function selection | 35: MPO (in "external mode" the manually operation cycle mode is chosen.)  | 0             | 87   |
|                                 |                  |                        | 36: TRI(triangle wave function is chosen)  |               |      |
|                                 |                  |                        | 37: Reserved   |               |      |
|                                 |                  |                        | 38: Reserved   |               |      |
|                                 |                  |                        | 39: STF/STR +STOP (The motor has a reverse rotation when the RUN signal is on. When the RUN signal is off, stop the motor and then run the motor for forward rotation. |               |      |
|                                 |                  |                        | 40: P_MRS (the inverter output instantaneously stops, The MRS is pulse signal input)   |               |      |
|                                 |                  |                        | 42: Reserved   |               |      |
|                                 |                  |                        | 43: RUN_EN (the digital input terminal running enable)   |               |      |
|                                 |                  |                        | 44: PID_OFF (the digital input terminal stopping PID enable)   |               |      |
|                                 |                  |                        | 45: The second mode  |               |      |
| 03-01                           | P.84             | STRfunction selection  | Same as 03-00  | 1             | 88   |
| 03-03                           | P.80             | M0 function selection  | Same as 03-00  | 2             | 88   |
| 03-04                           | P.81             | M1 function selection  | Same as 03-00  | 3             | 88   |
| 03-11                           | P.85             | A-C function selection | 0: RUN(inverter running)   | 5             | 90   |
|                                 |                  |                        | 1: SU(reaching the output frequency)   |               |      |
|                                 |                  |                        | 2: FU(output frequency detection)  |               |      |
|                                 |                  |                        | 3: OL(overload detection)  |               |      |
|                                 |                  |                        | 4: OMD(zero current detection)   |               |      |
|                                 |                  |                        | 5: ALARM(alarm detection)  |               |      |
|                                 |                  |                        | 6: PO1(programmed operation section detection)   |               |      |
|                                 |                  |                        | 7: PO2(programmed operation periodical detection)  |               |      |
|                                 |                  |                        | 8: PO3(programmed operation pause detection)   |               |      |
|                                 |                  |                        | 9: Reserved  |               |      |
|                                 |                  |                        | 10:Reserved  |               |      |
|                                 |                  |                        | 11: OMD1(zero current detection)   |               |      |
|                                 |                  |                        | 12: OL2 (Over torque alarm output)   |               |      |
|                                 |                  |                        | 13 ~ 16: Reserved  |               |      |
|                                 |                  |                        | 17: RY(the accomplishment of inverter running preparation)   |               |      |
| 18: Maintenance alarm detection |                  |                        |  |               |      |

Digital input/ output parameter group03

| Group | Parameter Number | Name   | Setting Range                             | Factory Value | Page |
|-------|------------------|--|---|---------------|------|
| 03-14 | P.87             | Multi-function terminal digital input negative/positive logic  | 0 ~ 15                                    | 0             | 91   |
| 03-15 | P.88             | Multi-function terminal digital output negative/positive logic | 0 ~ 3                                     | 0             | 91   |
| 03-16 | P.120            | Output signal delay time                                       | 0 ~ 3600.0s                               | 0.0s          | 92   |
| 03-17 | P.157            | Digital input terminal filter time                             | 0 ~ 2000                                  | 4             | 92   |
| 03-18 | P.158            | Digital input terminal power enable                            | 0: Digital input terminal power disable   | 0             | 93   |
|       |                  |  | 1: Digital input terminal power enable    |               |      |
| 03-20 | P.41             | Up-to-frequency sensitivity                                    | 0 ~ 100.0%                                | 10.0%         | 93   |
| 03-21 | P.42             | Output frequency detection for forward rotation                | 0 ~ 650.00Hz                              | 6.00Hz        | 93   |
| 03-22 | P.43             | Output frequency detection for reverse rotation                | 0 ~ 650.00Hz                              | 99999         | 93   |
|       |                  |  | 99999: Same as the setting of 03-21(P.42) |               |      |
| 03-23 | P.62             | Zero current detection level                                   | 0 ~ 200.0%                                | 5.0%          | 94   |
|       |                  |  | 99999: Function invalid                   |               |      |
| 03-24 | P.63             | Zero current detection time                                    | 0.05 ~ 100.00s                            | 0.50s         | 94   |
|       |                  |  | 99999: Function invalid                   |               |      |

## 5.4.1 Function selection of digital input

- ◆ Use the following parameters to select or change the digital input terminal functions. Any function from 0 to 45 can be selected by each terminal (Note 1).

| Parameter     | Name  | Factory Value | Setting Range | Content   |
|---------------|---|---------------|---------------|---|
| 03-00<br>P.83 | STF function selection                                      | 0             | 0             | STF(the inverter runs forward)  |
|               |   |               | 1             | STR(the inverter runs reverse)  |
|               |   |               | 2             | RL(Multi-speed low speed)   |
|               |   |               | 3             | RM(Multi-speed medium speed)  |
|               |   |               | 4             | RH(multi-speed high speed)  |
|               |   |               | 5             | Reserved  |
|               |   |               | 6             | The external thermal relay operation  |
|               |   |               | 7             | MRS(the instantaneous stopping of the inverter output)  |
|               |   |               | 8             | RT(the inverter second function)  |
|               |   |               | 9             | EXT(external JOG)   |
|               |   |               | 10            | STF+EXJ   |
|               |   |               | 11            | STR+EXJ   |
|               |   |               | 12            | STF+RT  |
|               |   |               | 13            | STR+RT  |
|               |   |               | 14            | STF+RL  |
|               |   |               | 15            | STR+RL  |
|               |   |               | 16            | STF+RM  |
|               |   |               | 17            | STR+RM  |
|               |   |               | 18            | STF+RH  |
|               |   |               | 19            | STR+RH  |
|               |   |               | 20            | STF+RL+RM   |
|               |   |               | 21            | STR+RL+RM   |
|               |   |               | 22            | STF+RT+RL   |
|               |   |               | 23            | STR+RT+RL   |
|               |   |               | 24            | STF+RT+RM   |
|               |   |               | 25            | STR+RT+RM   |
|               |   |               | 26            | STF+RT+RL+RM  |
|               |   |               | 27            | STR+RT+RL+RM  |
|               |   |               | 28            | RUN(the inverter runs forward)  |
|               |   |               | 29            | STF/STR(it is used with RUN, when STF/ STR is "on", the inverter runs reverse ; when STF/STR is "off", the inverter runs forward) |
|               |   |               | 30            | RES(external reset function)  |
|               |   |               | 31            | STOP(it can be used as a three-wire mode with the RUN signal or the STF-STR terminal)   |
|               |   |               | 32            | REX(multi-speed set (16 levels))  |
| 33            | PO(in "external mode", programmed operation mode is chosen) |               |               |   |

| Parameter     | Name                  | Factory Value | Setting Range | Content  |
|---------------|-----------------------|---------------|---------------|--|
| 03-00<br>P.83 | STFfunction selection | 0             | 34            | RES_E (external reset become valid only when the alarm goes off.)  |
|               |                       |               | 35            | MPO (in "external mode" the manually operation cycle mode is chosen.)  |
|               |                       |               | 36            | TRI(triangle wave function is chosen)  |
|               |                       |               | 37            | Reserved   |
|               |                       |               | 38            | Reserved   |
|               |                       |               | 39            | STF/STR +STOP (The motor has a reverse rotation when the RUN signal is on. When the RUN signal is off, stop the motor and then run the motor for forward rotation. |
|               |                       |               | 40            | P_MRS (the inverter output instantaneously stops, The MRS is pulse signal input)   |
|               |                       |               | 42            | Reserved   |
|               |                       |               | 43            | RUN_EN (the digital input terminal running enable)   |
|               |                       |               | 44            | PID_OFF (the digital input terminal stopping PID enable)   |
| 45            | The second mode       |               |               |  |
| 03-01<br>P.84 | STRfunction selection | 1             | Same as 03-00 | Same as 03-00  |
| 03-03<br>P.80 | M0 function selection | 2             | Same as 03-00 | Same as 03-00  |
| 03-04<br>P.81 | M1 function selection | 3             | Same as 03-00 | Same as 03-00  |

#### Setting Function selection of digital input

- ◆ The default value are 03-03=2(RL), 03-04=3(RM), 03-00=0(STF), 03-01=1(STR).
- ◆ If the setting of 03-01, 03-02, 03-03 and 03-04 are changed, the functions of the terminals are modified too. For example, when 03-03 is equal to 2, the M0 terminal is used for RL. When 03-03 is changed to 8, than the M0 terminal function will be changed to RT, i.e., the second function selection terminal. Take another example, if 03-00 is equal to 0, the STF terminal will be STF forward rotation function. When 03-00 is changed to 6, then STF terminal function will be changed OH, i.e., the external thermal relay terminal.
- ◆ Wiring for the external thermal relay (OH): for the conventional motor wiring, the external thermal relay is often placed at the front of the motor to prevent the motor from overheating. When the external thermal relay is separated, the alarm of the inverter will be tripped off and "OHT" will be displayed on the screen.
- ◆ The operation of the inverter can be controlled by four means ("1" for terminal close, "0" for terminal open, and X = 0, 1, 2, 3, 4, 6).
  - 1) Two-wire control mode 1:

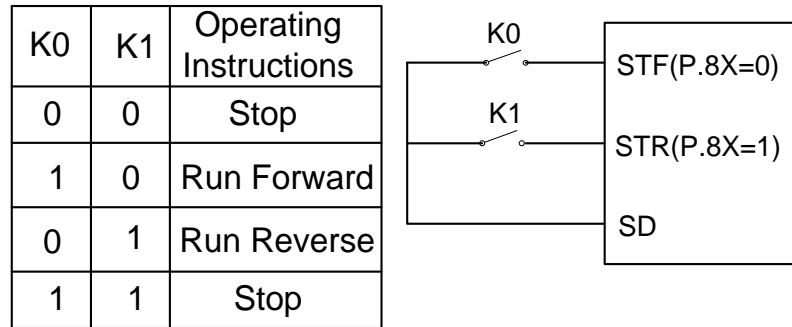

2) Two-wire control mode 2:

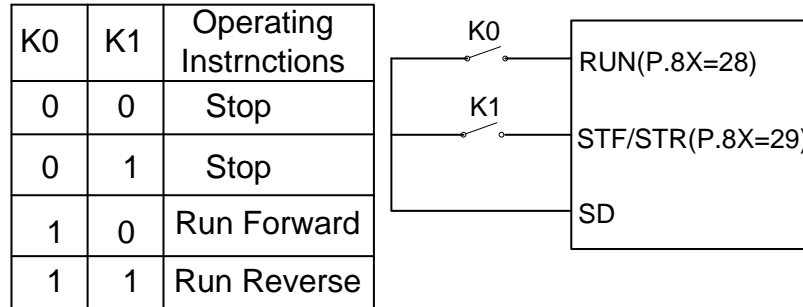

3) Three-wire control mode 1 (with self-maintenance function): K0 is for the STOP function that is normally close. When it is open, the inverter will stop. K1 and K2 is the forward and reverse signals that are normally open. They indicate that pulse signal is active, i.e., jog is valid.

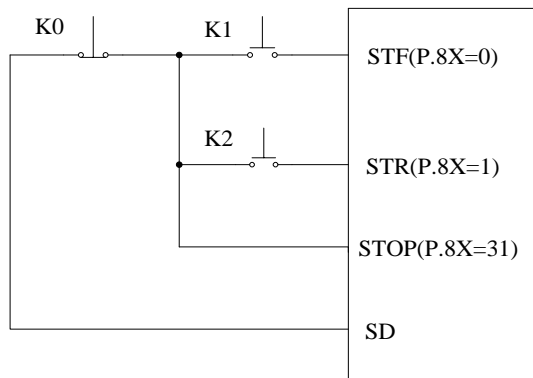

4) Three-wire control mode 2 (with self-maintenance function): K1 is for the STOP function that is normally close. When it is open, the inverter will stop. K2 is the RUN signal that is normally open. It indicates that pulse signal is active, i.e., jog is valid. For the direction changing signal (STF/STR), the parameter corresponds to the digital input terminals is 39. When changing the direction, stop the inverter first, RUN the inverter before activating it.

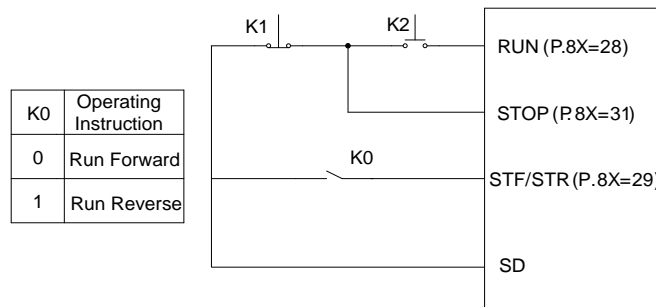

- ◆ In “external mode” and when PO is “on”, select the programmed operation mode. At this stage, the STF terminal is the source of the start signal. When STF is “on”, the inverter begins to run in the programmed operation mode at the first section. When STF is “off”, the inverter stops running, and STR becomes the pause signal source. When

## Digital input/ output parameter group03

STR is "on", the operation will be suspended. When STR is "off", the operation will be continued (continues from the suspended section). For details, please refer to 04-15, 04-27~04-42, 04-16~04-18 and 04-19~04-26.

- ◆ In the external mode, the manual operation cycle mode is selected when MPO is "on". For details on parameter, please refer to 04-19~04-26.
- ◆ The second set frequency source selection  
When the contact is ON, the target frequency is set by 00-17(P.97).

### 5.4.2 Function selection of digital output

- ◆ Detect the message during the inverter operation.

| Parameter     | Name   | Factory Value | Setting Range | Content  |
|---------------|--|---------------|---------------|--|
| 03-11<br>P.85 | A-C function selection                                 | 5             | 0             | RUN(inverter running) : Above the inverter start frequency output signal during operation  |
|               |  |               | 1             | SU(reaching the output frequency) : The output frequency to the frequency set checked out  |
|               |  |               | 2             | FU(output frequency detection) : Check out the above specified frequency output signal during operation  |
|               |  |               | 3             | OL(overload detection) : Current limiting function moves the output signal   |
|               |  |               | 4             | OMD (zero current detection): when the percentage of the output current is lower than the setting value of 03-23(P.62), and exceeds a period of time (03-24(P.63)), OMD will output signal.  |
|               |  |               | 5             | ALARM(alarm detection)   |
|               |  |               | 6             | PO1(programmed operation section detection)  |
|               |  |               | 7             | PO2(programmed operation periodical detection)   |
|               |  |               | 8             | PO3(programmed operation pause detection)  |
|               |  |               | 9             | Reserved   |
|               |  |               | 10            | Reserved   |
|               |  |               | 11            | OMD1(zero current detection): When the inverter output frequency reaches the target frequency, and the percentage of the output current is lower than the setting value of 03-23(P.62), and exceeds a period of time (03-24(P.63) setting), OMD1 will output signal. |
|               |  |               | 12            | OL2 (Over torque alarm output)   |
|               |  |               | 13 ~ 16       | Reserved   |
| 17            | RY(the accomplishment of inverter running preparation) |               |               |  |
| 18            | Maintenance alarm detection                            |               |               |  |

Setting Function selection of digital output

- ◆ For multi-function relay A-C, the default setting value of 03-11 is 5 (i.e., the alarm function). When the value of 03-11 is revised, its function will change respectively according to the function listed in the table above.

### 5.4.3 Terminal logic selection

- ◆ The function is bits-setting, if the bit shows 1, it means that the action of multi-function digital input terminal is negative logic; otherwise, it means that the action is positive logic.

| Parameter     | Name   | Factory Value | Setting Range | Content                            |
|---------------|--|---------------|---------------|------------------------------------|
| 03-14<br>P.87 | Multi-function terminal digital input negative/positive logic  | 0             | 0 ~ 15        | ---                                |
| 03-15<br>P.88 | Multi-function terminal digital output negative/positive logic | 0             | 0             | 0 : A-C output is positive logical |
|               |  |               | 2             | 2 : A-C output is negative         |

**Setting** Digital input/output logic

- ◆ The definition of each bit of 03-14(P.87) is as follows:

| bit | $2^3$ | $2^2$ | $2^1$ | $2^0$ |
|-----|-------|-------|-------|-------|
|     | M1    | M0    | STR   | STF   |

For example: A three-wire control type needs the function of STOP to be kept open (negative logic). So if set 03-03(P.80)=31, take M0 terminal as three-wire control STOP function, and 03-03(P.80)=0, 03-01(P.84)=1, and take STF and STR terminals as default positive/negative logic function, the parameter of 03-14(P.87) should be set as follows:

| bit | $2^3$ | $2^2$ | $2^1$ | $2^0$ |
|-----|-------|-------|-------|-------|
|     | 0     | 1     | 0     | 0     |

$$\text{So}(03-14)\text{P.87} = 0 \times 2^5 + 0 \times 2^4 + 0 \times 2^3 + 1 \times 2^2 + 0 \times 2^1 + 0 \times 2^0 = 4$$

- ◆ The definition of each 03-15(P.88) bit is as follows :

For example: 03-11(P.85) =0 (inverter is running and detecting), if positive logic output bit is set as 0, when inverter runs, multi-relay is on. When inverter stops, multi-relay is off; otherwise, if set negative logic bit as 1, when inverter runs, multi-relay is offhand when the inverter stops, multi-relay is on.

Note: When “STF” and “STR” terminals are set as negative logic, but signal is not connected with SD, with power on, inverter will input and drive motor operate. So it is dangerous, you must pay attention to it.

### 5.4.4 Output signal delay

- ◆ It is used for digital output terminal signal delay and confirmation. The delay time is confirmation time to prevent some uncertain interference.

| Parameter      | Name                     | Factory Value | Setting Range | Content |
|----------------|--------------------------|---------------|---------------|---------|
| 03-16<br>P.120 | Output signal delay time | 0.0s          | 0 ~ 3600.0s   | ---     |

 Output signal delay

- ◆ When 03-16=0 and the setting requirements of 03-10(03-11, 03-12, 03-13) is met, the signal will output directly.
- ◆ When 03-16 = 0.1~3600 and the setting requirements of 03-10(03-11, 03-12, 03-13) is met, the signal will output after a setting delay time.

### 5.4.5 Digital input terminal filter

- ◆ It is used to select response time to the signal of digital input terminals.

| Parameter      | Name                          | Factory Value | Setting Range | Content |
|----------------|-------------------------------|---------------|---------------|---------|
| 03-17<br>P.157 | Digital input terminal filter | 4             | 0 ~ 2000      | ---     |

 Digital input terminal filter

- ◆ 03-17is used to select response time to the signal of digital input terminals, and its action range including:STR, STF, M0, and M1. And the actual delay time is 03-17\*2ms. For example, if 03-17=100, the actual delay time is 200ms.

### 5.4.6 Digital input terminal power enable

- ◆ Selects power enables on the digital input terminal, whether the inverter operates immediately.

| Parameter      | Name                                | Factory Value | Setting Range | Content                               |
|----------------|-------------------------------------|---------------|---------------|---------------------------------------|
| 03-18<br>P.158 | Digital input terminal power enable | 0             | 0             | Digital input terminal power disable. |
|                |                                     |               | 1             | Digital input terminal power enable.  |

**Settin** Digital input terminal power enable

- ◆ If 03-18=1, select power enables on the digital input terminals. In this situation, if the functions of the multi-function digital input terminals before turning on the power are STF, STR, RUN and MPO, and the corresponded digital input terminals are short circuit, and then the inverter will not run immediately after turning on the power. The inverter will run only after short circuit these terminals again. When 03-18=0, make these terminal short circuit before turning on the power, and the inverter will run immediately after the power is turned on.

### 5.4.7 Output frequency detection

- ◆ Detects the inverter output frequency, and with the output signal.

| Parameter     | Name  | Factory Value | Setting Range | Content                      |
|---------------|---|---------------|---------------|------------------------------|
| 03-20<br>P.41 | Up-to-frequency sensitivity                     | 10.0%         | 0 ~ 100.0%    | ---                          |
| 03-21<br>P.42 | Output frequency detection for forward rotation | 6.00Hz        | 0 ~ 650.00Hz  | ---                          |
| 03-22<br>P.43 | Output frequency detection for reverse rotation | 99999         | 0 ~ 650.00Hz  | ---                          |
|               |   |               | 99999         | Set the same as 03-21(P.42). |

**Settin** Up-to-frequency sensitivity

- ◆ If 03-20=5%, when the output frequency enters the “5% region near the target frequency”, it will send out SU signals. For example, when the target frequency is set to 60Hz and 03-20=5%, then if the output frequency is between  $60 \pm 60 \times 5\% = 57\text{Hz}$  and 63Hz, a SU signal will be sent out.

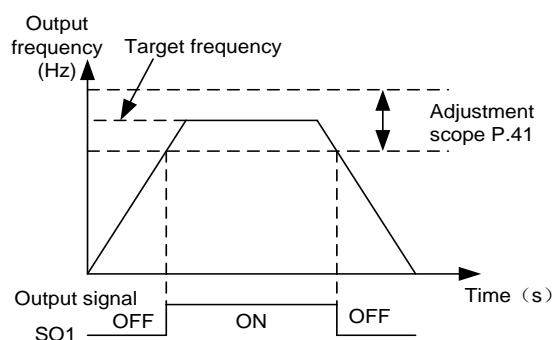

**Settin** Output frequency detection for forward / reverse rotation

- ◆ If 03-21=30 and 03-22=20, then it will send out FU signals when the forward rotation output frequency exceeds 30Hz or when the reverse rotation output frequency exceeds 20Hz.
- ◆ If 03-21=30 and 03-22=99999 (factory default), then it will send out FU signals when the forward or reverse rotation output frequency exceeds 30Hz.

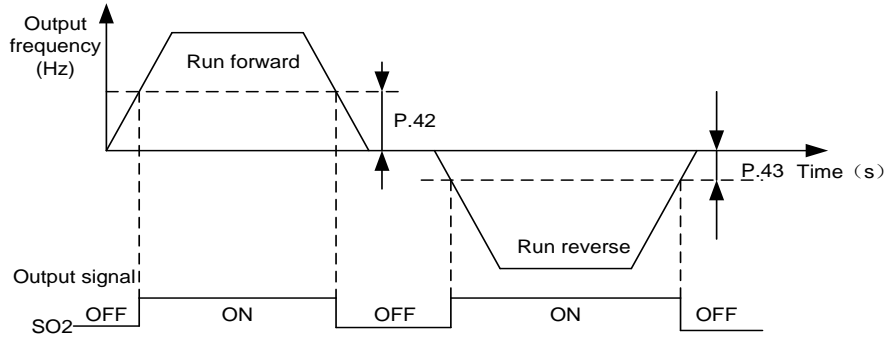

Note: In this paragraph, SU, FU is the function name for “multi-function digital output terminal” SO1, SO2. Please refer to 03-10 ~ 03-13. For wiring, please refer to Section 3.7.

5.4.8 Zero current detection

- ◆ Detects the output frequency to the output terminal.

| Parameter     | Name                         | Factory Value | Setting Range  | Content  |
|---------------|------------------------------|---------------|----------------|----------|
| 03-23<br>P.62 | Zero current detection level | 5.0%          | 0 ~ 200.0%     | ---      |
|               |                              |               | 99999          | Invalid. |
| 03-24<br>P.63 | Zero current detection time  | 0.50s         | 0.05 ~ 100.00s | ---      |
|               |                              |               | 99999          | Invalid. |

**Settin** Zero current detection

- ◆ Assume the inverter's rated is full-loaded, the current is 20A, 03-23=5% and 03-24=0.5s, then when the output current is smaller than  $20 \times 5\% = 1A$  and exceeding 0.5s, OMD will send out signals. See the figure below:

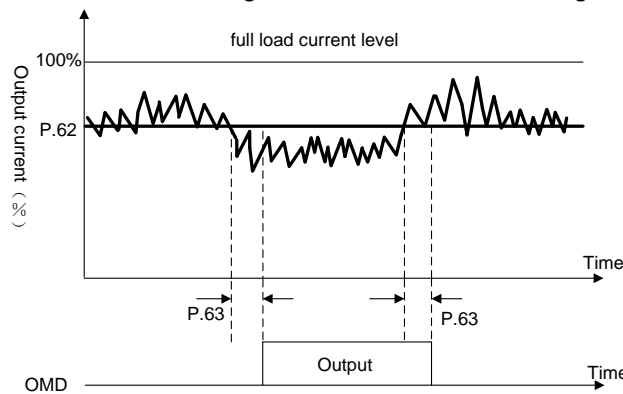

- ◆ If the set value of 03-23 or 03-24 is 99999, the zero current detection function is disabled.

Note: In this paragraph, OMD is the function name for “multi-function digital output terminal”. Please refer to 03-00, 03-01, 03-03 and 03-04 for wiring, please refer to Section 3.7.

## 5.5 Multi-speed parameter group04

| Group | Parameter Number | Name   | Setting Range  | Factory Value | Page |
|-------|------------------|--|--|---------------|------|
| 04-00 | P.4              | Speed1(high speed)                               | 0 ~ 650.00Hz   | 60.00Hz       | 97   |
| 04-01 | P.5              | Speed2(medium speed)                             | 0 ~ 650.00Hz   | 30.00Hz       | 97   |
| 04-02 | P.6              | Speed3(low speed)                                | 0 ~ 650.00Hz   | 10.00Hz       | 97   |
| 04-03 | P.24             | Speed4   | 0 ~ 650.00Hz   | 99999         | 97   |
|       |                  |  | 99999: Function invalid  |               |      |
| 04-04 | P.25             | Speed5   | Same as 04-03  | 99999         | 97   |
| 04-05 | P.26             | Speed6   | Same as 04-03  | 99999         | 97   |
| 04-06 | P.27             | Speed7   | Same as 04-03  | 99999         | 97   |
| 04-07 | P.142            | Speed8   | 0 ~ 650.00Hz   | 99999         | 97   |
| 04-08 | P.143            | Speed9   | Same as 04-03  | 99999         | 97   |
| 04-09 | P.144            | Speed10  | Same as 04-03  | 99999         | 97   |
| 04-10 | P.145            | Speed11  | Same as 04-03  | 99999         | 97   |
| 04-11 | P.146            | Speed12  | Same as 04-03  | 99999         | 97   |
| 04-12 | P.147            | Speed13  | Same as 04-03  | 99999         | 97   |
| 04-13 | P.148            | Speed14  | Same as 04-03  | 99999         | 97   |
| 04-14 | P.149            | Speed15  | Same as 04-03  | 99999         | 97   |
| 04-15 | P.100            | Minute/second selection                          | 0: The minimum increment of run time is 1 minute.  | 1             | 99   |
|       |                  |  | 1: The minimum increment of run time is 1 second.  |               |      |
| 04-16 | P.121            | Run direction in each section                    | 0 ~ 255  | 0             | 99   |
| 04-17 | P.122            | Cycle selection                                  | 0: Cycle function invalid  | 0             | 99   |
|       |                  |  | 1 ~ 8: Run circularly from the setting section.  |               |      |
| 04-18 | P.123            | Acceleration/deceleration time setting selection | 0: The acceleration time is set by 01-06(P.7); the deceleration time is set by 01-07(P.8).   | 0             | 99   |
|       |                  |  | 1: The acceleration and deceleration time is both determined by 04-35(P.111) ~ 04-42(P.118). |               |      |
| 04-19 | P.131            | Programmed operation mode speed 1                | 0 ~ 650.00Hz   | 0.00 Hz       | 99   |
| 04-20 | P.132            | Programmed operation mode speed 2                | 0 ~ 650.00Hz   | 0.00 Hz       | 99   |
| 04-21 | P.133            | Programmed operation mode speed3                 | 0 ~ 650.00Hz   | 0.00 Hz       | 99   |
| 04-22 | P.134            | Programmed operation mode speed 4                | 0 ~ 650.00Hz   | 0.00 Hz       | 99   |
| 04-23 | P.135            | Programmed operation mode speed 5                | 0 ~ 650.00Hz   | 0.00 Hz       | 99   |
| 04-24 | P.136            | Programmed operation mode speed 6                | 0 ~ 650.00Hz   | 0.00 Hz       | 99   |
| 04-25 | P.137            | Programmed operation mode speed 7                | 0 ~ 650.00Hz   | 0.00 Hz       | 99   |
| 04-26 | P.138            | Programmed operation mode speed 8                | 0 ~ 650.00Hz   | 0.00 Hz       | 99   |

## Multi-speed parameter group04

| Group | Parameter Number | Name   | Setting Range           | Factory Value | Page |
|-------|------------------|--|-------------------------|---------------|------|
| 04-27 | P.101            | Programmed operation mode speed 1 operating time | 0 ~ 6000.0s             | 0.0s          | 99   |
| 04-28 | P.102            | Programmed operation mode speed 2 operating time | 0 ~ 6000.0s             | 0.0s          | 99   |
| 04-29 | P.103            | Programmed operation mode speed3 operating time  | 0 ~ 6000.0s             | 0.0s          | 99   |
| 04-30 | P.104            | Programmed operation mode speed 4 operating time | 0 ~ 6000.0s             | 0.0s          | 99   |
| 04-31 | P.105            | Programmed operation mode speed 5 operating time | 0 ~ 6000.0s             | 0.0s          | 100  |
| 04-32 | P.106            | Programmed operation mode speed 6 operating time | 0 ~ 6000.0s             | 0.0s          | 100  |
| 04-33 | P.107            | Programmed operation mode speed 7 operating time | 0 ~ 6000.0s             | 0.0s          | 100  |
| 04-34 | P.108            | Programmed operation mode speed 8 operating time | 0 ~ 6000.0s             | 0.0s          | 100  |
| 04-35 | P.111            | Programmed operation mode speed 1 Acc/Dec time   | 0 ~ 600.00s/0 ~ 6000.0s | 0.00s         | 100  |
| 04-36 | P.112            | Programmed operation mode speed 2 Acc/Dec time   | 0 ~ 600.00s/0 ~ 6000.0s | 0.00s         | 100  |
| 04-37 | P.113            | Programmed operation mode speed 3 Acc/Dec time   | 0 ~ 600.00s/0 ~ 6000.0s | 0.00s         | 100  |
| 04-38 | P.114            | Programmed operation mode speed 4 Acc/Dec time   | 0 ~ 600.00s/0 ~ 6000.0s | 0.00s         | 100  |
| 04-39 | P.115            | Programmed operation mode speed 5 Acc/Dec time   | 0 ~ 600.00s/0 ~ 6000.0s | 0.00s         | 100  |
| 04-40 | P.116            | Programmed operation mode speed 6 Acc/Dec time   | 0 ~ 600.00s/0 ~ 6000.0s | 0.00s         | 100  |
| 04-41 | P.117            | Programmed operation mode speed 7Acc/Dec time    | 0 ~ 600.00s/0 ~ 6000.0s | 0.00s         | 100  |
| 04-42 | P.118            | Programmed operation mode speed 8 Acc/Dec time   | 0 ~ 600.00s/0 ~ 6000.0s | 0.00s         | 100  |

## 5.5.1 16 speeds

- ◆ With the combination of digital input terminal RL, RM, RH and REX, selects speed operation (the most are 16 speeds in total)

| Parameter      | Name                     | Factory Value | Setting Range | Content                 |
|----------------|--------------------------|---------------|---------------|-------------------------|
| 04-00<br>P.4   | Speed1(high speed)       | 60.00Hz       | 0 ~ 650.00Hz  | ---                     |
| 04-01<br>P.5   | Speed2<br>(medium speed) | 30.00Hz       | 0 ~ 650.00Hz  | ---                     |
| 04-02<br>P.6   | Speed3(low speed)        | 10.00Hz       | 0 ~ 650.00Hz  | ---                     |
| 04-03<br>P.24  | Speed4                   | 99999         | 0 ~ 650.00Hz  | ---                     |
|                |                          |               | 99999         | 99999: Function invalid |
| 04-04<br>P.25  | Speed5                   | 99999         | Same as 04-03 | Same as 04-03           |
| 04-05<br>P.26  | Speed6                   | 99999         | Same as 04-03 | Same as 04-03           |
| 04-06<br>P.27  | Speed7                   | 99999         | Same as 04-03 | Same as 04-03           |
| 04-07<br>P.142 | Speed8                   | 99999         | 0 ~ 650.00Hz  | ---                     |
| 04-08<br>P.143 | Speed9                   | 99999         | Same as 04-03 | Same as 04-03           |
| 04-09<br>P.144 | Speed10                  | 99999         | Same as 04-03 | Same as 04-03           |
| 04-10<br>P.145 | Speed11                  | 99999         | Same as 04-03 | Same as 04-03           |
| 04-11<br>P.146 | Speed12                  | 99999         | Same as 04-03 | Same as 04-03           |
| 04-12<br>P.147 | Speed13                  | 99999         | Same as 04-03 | Same as 04-03           |
| 04-13<br>P.148 | Speed14                  | 99999         | Same as 04-03 | Same as 04-03           |
| 04-14<br>P.149 | Speed15                  | 99999         | Same as 04-03 | Same as 04-03           |

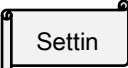
 16 speeds

- ◆ If all the set values of 04-03~04-06 and 04-07~04-14 are not 99999, “16-speed operation” is active. It means that with the combination of RL, RM, RH and REX, there are 16 speeds in total. For setting up the target frequency of the inverter, please refer to the figure below:

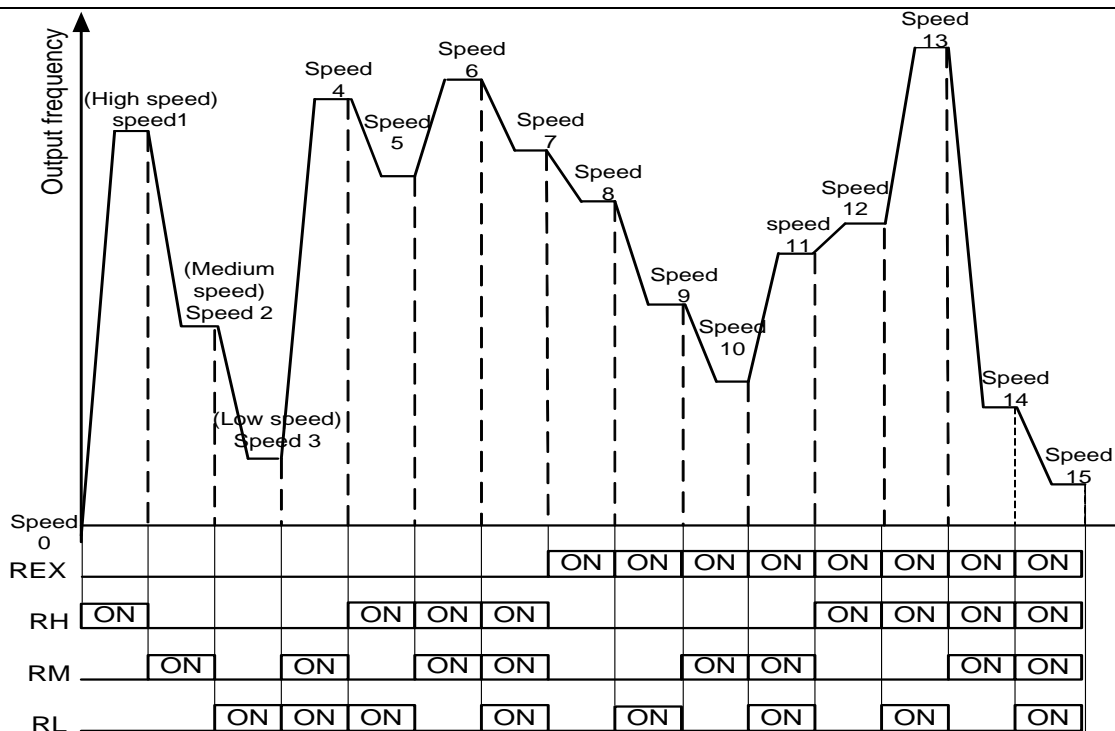

- ◆ Provided that the parameter set values of 04-03~04-06 and 04-07~04-14 are all 99999, the target frequency will be determined by RL, RM and RH these three speeds. See the table below (the priority of the terminals is RL>RM>RH):

| Parameter<br>Target<br>frequency | 04-03=<br>99999 | 04-04=<br>99999 | 04-05=<br>99999 | 04-06=<br>99999 | 04-07=<br>99999 | 04-08=<br>99999 | 04-09=<br>99999 | 04-10=<br>99999 | 04-11=<br>99999 | 04-12=<br>99999 | 04-13=<br>99999 | 04-14=<br>99999 |
|----------------------------------|-----------------|-----------------|-----------------|-----------------|-----------------|-----------------|-----------------|-----------------|-----------------|-----------------|-----------------|-----------------|
| RL(04-02)                        | ○               | ○               |                 | ○               | ○               | ○               |                 | ○               |                 | ○               |                 | ○               |
| RM(04-01)                        |                 |                 | ○               |                 |                 |                 | ○               |                 |                 |                 | ○               |                 |
| RH(04-00)                        |                 |                 |                 |                 |                 |                 |                 |                 | ○               |                 |                 |                 |

For example, when 04-05 = 99999, the target frequency is determined by RM (the setting value of 04-01).

Note: 1. The multi-speed is only valid in the “external mode”, “combination mode 2” or “combined mode 4”.  
 2. RL, RM, RH and REX mentioned in this section are the function names of the “multi-function digital input terminal”. (For example, when 03-03=2, select the M0 terminal to perform the RL (function). Please refer to 03-00, 03-01, 03-03 and 03-04 for function selection and purposes of the multi-function digital input terminal. For related wiring, please refer to Section 3.7.

## 5.5.2 Programmed operation mode

- ◆ The application of this parameter can be used as the operation process control for general small machinery, food processing machinery and washing equipment, which can replace some traditional relays, switches, timer and other control circuit, etc.

| Parameter      | Name   | Factory Value | Setting Range | Content   |
|----------------|--|---------------|---------------|---|
| 04-15<br>P.100 | Minute/second selection                          | 1             | 0             | The minimum increment of run time is 1 minute.  |
|                |  |               | 1             | The minimum increment of run time is 1 second.  |
| 04-16<br>P.121 | Run direction in each section                    | 0             | 0 ~ 255       | 0 ~ 255   |
| 04-17<br>P.122 | Cycle selection                                  | 0             | 0             | 0: Cycle function invalid   |
|                |  |               | 1 ~ 8         | Run circularly from the setting section.  |
| 04-18<br>P.123 | Acceleration/deceleration time setting selection | 0             | 0             | The acceleration time is set by 01-06(P.7); the deceleration time is set by 01-07(P.8).   |
|                |  |               | 1             | The acceleration and deceleration time is both determined by 04-35(P.111) ~ 04-42(P.118). |
| 04-19<br>P.131 | Programmed operation mode speed 1                | 0.00Hz        | 0 ~ 650.00Hz  | ---   |
| 04-20<br>P.132 | Programmed operation mode speed 2                | 0.00Hz        | 0 ~ 650.00Hz  | ---   |
| 04-21<br>P.133 | Programmed operation mode speed3                 | 0.00Hz        | 0 ~ 650.00Hz  | ---   |
| 04-22<br>P.134 | Programmed operation mode speed 4                | 0.00Hz        | 0 ~ 650.00Hz  | ---   |
| 04-23<br>P.135 | Programmed operation mode speed 5                | 0.00Hz        | 0 ~ 650.00Hz  | ---   |
| 04-24<br>P.136 | Programmed operation mode speed 6                | 0.00Hz        | 0 ~ 650.00Hz  | ---   |
| 04-25<br>P.137 | Programmed operation mode speed 7                | 0.00Hz        | 0 ~ 650.00Hz  | ---   |
| 04-26<br>P.138 | Programmed operation mode speed 8                | 0.00Hz        | 0 ~ 650.00Hz  | ---   |
| 04-27<br>P.101 | Programmed operation mode speed 1 operating time | 0.0s          | 0 ~ 6000.0s   | ---   |
| 04-28<br>P.102 | Programmed operation mode speed 2 operating time | 0.0s          | 0 ~ 6000.0s   | ---   |
| 04-29<br>P.103 | Programmed operation mode speed3 operating time  | 0.0s          | 0 ~ 6000.0s   | ---   |
| 04-30<br>P.104 | Programmed operation mode speed 4 operating time | 0.0s          | 0 ~ 6000.0s   | ---   |

| Parameter      | Name   | Factory Value | Setting Range               | Content |
|----------------|--|---------------|-----------------------------|---------|
| 04-31<br>P.105 | Programmed operation mode speed 5 operating time | 0.0s          | 0 ~ 6000.0s                 | ---     |
| 04-32<br>P.106 | Programmed operation mode speed 6 operating time | 0.0s          | 0 ~ 6000.0s                 | ---     |
| 04-33<br>P.107 | Programmed operation mode speed 7 operating time | 0.0s          | 0 ~ 6000.0s                 | ---     |
| 04-34<br>P.108 | Programmed operation mode speed 8 operating time | 0.0s          | 0 ~ 6000.0s                 | ---     |
| 04-35<br>P.111 | Programmed operation mode speed 1 Acc/Dec time   | 0.00s         | 0 ~ 600.00s/<br>0 ~ 6000.0s | ---     |
| 04-36<br>P.112 | Programmed operation mode speed 2 Acc/Dec time   | 0.00s         | 0 ~ 600.00s/<br>0 ~ 6000.0s | ---     |
| 04-37<br>P.113 | Programmed operation mode speed 3 Acc/Dec time   | 0.00s         | 0 ~ 600.00s/<br>0 ~ 6000.0s | ---     |
| 04-38<br>P.114 | Programmed operation mode speed 4 Acc/Dec time   | 0.00s         | 0 ~ 600.00s/<br>0 ~ 6000.0s | ---     |
| 04-39<br>P.115 | Programmed operation mode speed 5 Acc/Dec time   | 0.00s         | 0 ~ 600.00s/<br>0 ~ 6000.0s | ---     |
| 04-40<br>P.116 | Programmed operation mode speed 6 Acc/Dec time   | 0.00s         | 0 ~ 600.00s/<br>0 ~ 6000.0s | ---     |
| 04-41<br>P.117 | Programmed operation mode speed 7 Acc/Dec time   | 0.00s         | 0 ~ 600.00s/<br>0 ~ 6000.0s | ---     |
| 04-42<br>P.118 | Programmed operation mode speed 8 Acc/Dec time   | 0.00s         | 0 ~ 600.00s/<br>0 ~ 6000.0s | ---     |

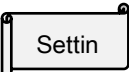
 Programmed operation mode

◆ Programmed operation mode

1. The calculation of runtime and acceleration/deceleration time in each section is presented in the figure below:

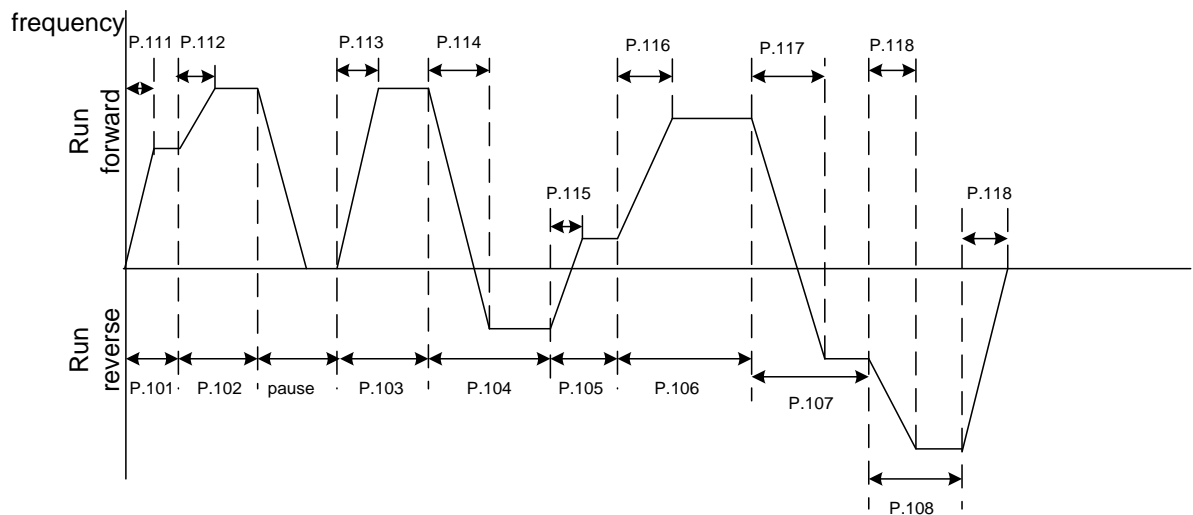

- The run direction is set in binary form (8-bit), and then translated to decimal form and stored in 04-16. "1" means run forward, and "0" means run reverse. The highest bit is the run direction of section 8, while the lowest bit is the direction of the section 1.

For example: Suppose that section 1 is run forward, section 2 is run reverse, section 3 is run reverse, section 4 is run forward, section 5 is run reverse, section 6 is run forward, section 7 is run forward, section 8 is run reverse, then the value in binary form is 01101001.

$$04-16 = 0 \times 2^7 + 1 \times 2^6 + 1 \times 2^5 + 0 \times 2^4 + 1 \times 2^3 + 0 \times 2^2 + 0 \times 2^1 + 1 \times 2^0 = 105$$

- When 04-16=0, it will not run in circular motion.
- When 04-17 is 1~8, it is the initial sectional speed at the beginning of the cycle.  
For example: When 04-17=3, the inverter will run circularly from the third section to the eighth section after it finishes its running from the first section to the eighth section.
- When 04-18 = 0, the acceleration time is determined by 01-06, and the deceleration time is determined by 01-07.
- When 04-18 = 1, the acceleration time and deceleration time are both determined by 04-35~04-42.

#### ◆ Manual operation cycle mode

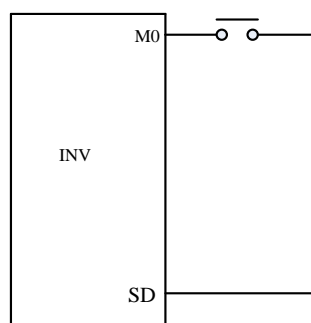

Wiring diagram for manual operation cycle mode

- Insert an impulse type switch between M0 and SD.
- After turning on the power, according to terminals wiring, set corresponding parameter 03-03 to 35. The inverter is on standby at this point.
- The mode of operation is shown in the figure below:

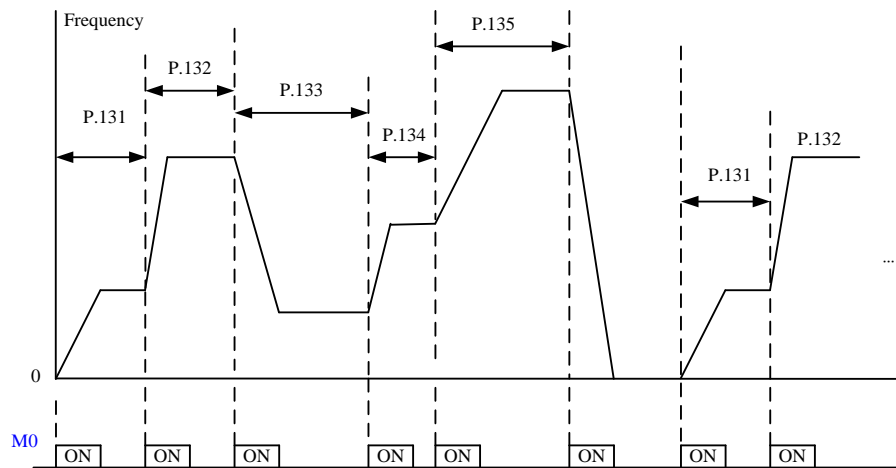

- Note: 1. The inverter can run eight levels of speed in the procedure, and the frequency is determined by 04-19~04-26.
2. For the setting of 04-15~04-18 and 04-27~04-42, it is valid for programmed operation mode only, not for manual operation cycle mode; For the acceleration/deceleration time of manual operation cycle mode, please refer to the usage of 01-06, 01-07, 01-22 and 01-23.
3. If there is any section set to zero, the inverter will be on standby in this section. In other word, 04-19 has to be nonzero when this mode is selected. Like the figure above, when 04-24 is 0, regardless of the value of 04-25 and 04-26, the inverter stops when the switch is pressed for the sixth time.
4. The rotation of the manual operation cycle mode is unilateralism. It has nothing to do with 04-16 or the signals of STF and STR.
5. For the setting of 04-35~04-42, please refer to 01-08 for the usage of the acceleration/deceleration time unit.

## 5.6 Motor parameter group05

| Group | Parameter Number | Name   | Setting Range  | Factory Value     | Page |
|-------|------------------|--|--|-------------------|------|
| 05-00 | P.301            | Motor parameter auto-tuning function selection | 0: Parameter auto-tuning function with no motor                      | 0                 | 104  |
|       |                  |  | 1: Induction motor parameter auto-tuning measuring the running motor |                   |      |
|       |                  |  | 2: Induction motor parameter auto-tuning measuring the stopped motor |                   |      |
|       |                  |  | 3: Induction motor online auto-tuning function                       |                   |      |
| 05-01 | P.302            | Motor rated power                              | 0 ~ 160.00kW   | 0.00kW            | 106  |
| 05-02 | P.303            | Motor poles                                    | 0 ~ 48   | 4                 | 106  |
| 05-03 | P.304            | Motor rated voltage                            | 0 ~ 440V   | 440               | 106  |
|       |                  |  | 0~220V   | 220               |      |
| 05-04 | P.305            | Motor rated frequency                          | 50Hz system: 0 ~ 650.00Hz  | 50.00Hz           | 106  |
|       |                  |  | 60Hz system: 0 ~ 650.00Hz  | 60.00Hz           |      |
| 05-05 | P.306            | Motor rated current                            | 0~500.00A  | According to type | 106  |
| 05-06 | P.307            | Motor rated rotation speed                     | 50Hz system: 0 ~ 9998r/min   | 1410r/min         | 106  |
|       |                  |  | 60Hzsystem: 0 ~ 9998r/min  | 1710r/min         |      |
| 05-07 | P.308            | Motor excitation current                       | 0~500.00A  | According to type | 106  |
| 05-08 | P.309            | IM motor stator resistance                     | 0~99.98Ω   | According to type | 106  |

## 5.6.1 Motor parameter auto-tuning function selection

- ◆ Via accurate motor parameter auto-tuning function, realizes motor high-performance vector control.

| Parameter      | Name   | Factory Value | Setting Range | Content   |
|----------------|--|---------------|---------------|---|
| 05-00<br>P.301 | Motor parameter auto-tuning function selection | 0             | 0             | Parameter auto-tuning function with no motor                      |
|                |  |               | 1             | Induction motor parameter auto-tuning measuring the running motor |
|                |  |               | 2             | Induction motor parameter auto-tuning measuring the stopped motor |
|                |  |               | 3             | Induction motor online auto-tuning function                       |

 Motor parameter auto-tuning function

- ◆ When 00-21=0, no motor parameter auto-tuning function is required for normal V/F curve operation.
- ◆ For IM general magnetic vector control please set 00-21 to 2. The frequency will be altered due to elevated voltage and increased compensatory motor load.
- ◆ For executing the IM motor parameter auto-tuning function, set 05-00 to 1 or 2 and press the forward rotation or the reverse rotation key. During the measuring process, the operation panel will flicker and display “TUN”. If the measurement fails, the operation panel will flicker “FAL” for three seconds and then return to normal display.
- ◆ Procedures for IM motor parameter auto-tuning are presented below:

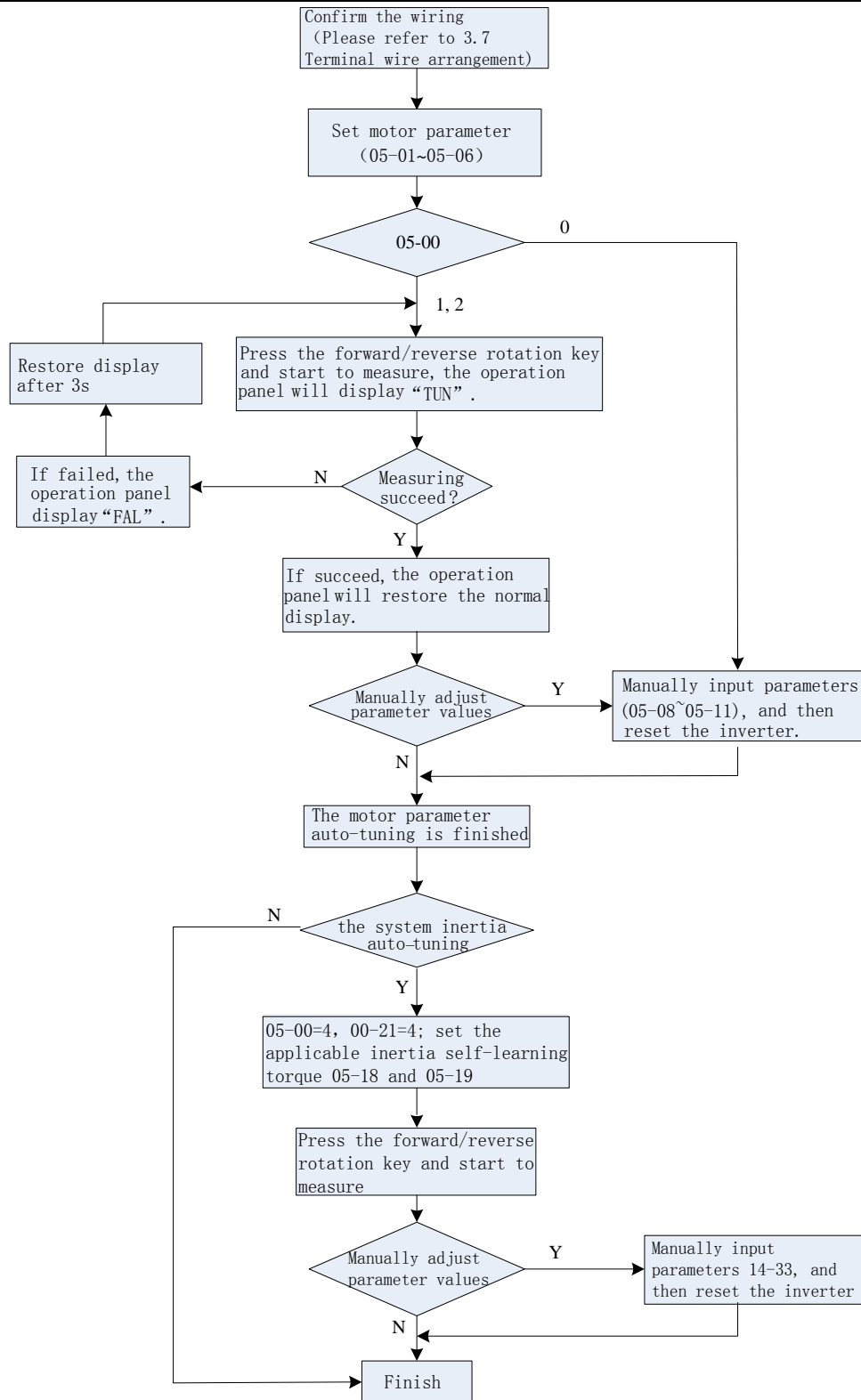

- Note: 1. The motor capacity has to be at the same level or one level below of the level of the capacity of the inverter.
2. For the IM motor auto-tuning function, if motor operation is permitted, set 05-00 to 1 (dynamic measurement). At this point, the load has to be separated from the motor. If the load environment does not permit auto-tuning, set 05-00 to 2 (static measurement) if motoring is running.
3. IM motor sensorless vector control: auto-tuning function can be used to enhance the control function. Before setting 05-00 to 3 or 4, first set the motor parameters or the auto-tuning function to improve the control accuracy.

## 5.6.2 Motor parameter

- ◆ The standard parameters of the adaptable motor have been configured inside the inverter. It is still necessary to perform motor auto-tuning or modify the default values based on actual conditions.

| Parameter      | Name                       | Factory Value     | Setting Range | Content                       |
|----------------|----------------------------|-------------------|---------------|-------------------------------|
| 05-01<br>P.302 | Motor rated power          | 0.00kW            | 0 ~ 160.00kW  | ---                           |
| 05-02<br>P.303 | Motor poles                | 4                 | 0 ~ 8         | ---                           |
| 05-03<br>P.304 | Motor rated voltage        | 380V/440V         | 0 ~ 510V      | 440V voltage 50Hz/60Hz system |
|                |                            | 220V              |               | 220Vvoltage                   |
| 05-04<br>P.305 | Motor rated frequency      | 50.00Hz           | 0 ~ 650.00Hz  | 50Hz system (when 00-24=1)    |
|                |                            | 60.00Hz           |               | 60Hz system (when 00-24=0)    |
| 05-05<br>P.306 | Motor rated current        | According to type | 0 ~ 500.00A   | Types below Frame G           |
| 05-06<br>P.307 | Motor rated rotation speed | 1410r/min         | 0 ~ 9998r/min | 50Hz system (when 00-24=1)    |
|                |                            | 1710r/min         |               | 60Hz system (when 00-24=0)    |
| 05-07<br>P.308 | Motor excitation current   | According to type | 0 ~ 500.00A   | Types below Frame G           |
| 05-08<br>P.309 | IM motor stator resistance | According to type | 0 ~ 99.98Ω    |                               |

### Setting Motor parameter

- ◆ When the IM motor can be fully separated from the load, select 05-00=1. When the motor is running, the motor parameter will carry out auto-tuning. Then press  or  on the keyboard panel for the inverter to automatically calculate the following parameter: 05-07~05-09.
- ◆ When the motor cannot be fully separated from the load, select 05-07=2. When the motor is stopped, the motor parameter will carry out auto-tuning. Then press  or  on the keyboard panel for the inverter to automatically calculate the following parameter: 05-07~05-09.
- ◆ The users can use the motor's nameplate to calculate the two parameters. The motor nameplate parameters used in the calculation are: rated voltage  $U$ , rated current  $I$ , rated frequency  $f$  and power factor  $\eta$ .
- ◆ The calculation of motor idling excitation current and of motor mutual induction is presented below:  $L_{\delta}$  is motor leakage induction.
- ◆ Idling current:  $I_0 = I \times \sqrt{1 - \eta^2}$ , Mutual inductance calculation:  $L_m = \frac{U}{2\sqrt{3} \cdot \pi \cdot f \cdot I_0} - L_s$

$I_0$  is the idling current,  $L_m$  is mutual inductance,  $L_{\delta}$  is leakage inductance.

Note: 1. When the inverter is used with a motor of a different level, verify the input motor's nameplate parameter 05-01~05-06. The vector control method is heavily dependent upon motor parameters. To achieve a good control performance, the controlled motor correct parameters have to be acquired.

2. When any or many values of 05-01~05-09 are manually revised, reset the inverter to reload the new values of the parameters.

## 5.7 Protection parameter group06

| Group | Parameter Number | Name  | Setting Range  | Factory Value     | Page |
|-------|------------------|---|--|-------------------|------|
| 06-00 | P.9              | Electronic thermal relay capacity                       | 0~500.00A  | According to type | 109  |
| 06-01 | P.22             | Stall prevention operation level                        | 0 ~ 250.0%   | 150.0%            | 109  |
| 06-02 | P.23             | Compensation factor at level reduction                  | 0 ~ 200.0%   | 99999             | 109  |
|       |                  |   | 99999: Stall prevention operation level is the setting value of 06-01(P.22).                           |                   |      |
| 06-03 | P.66             | Stall prevention operation reduction starting frequency | 50Hz system: 0 ~ 650.00Hz  | 50.00Hz           | 109  |
|       |                  |   | 60Hz system: 0 ~ 650.00Hz  | 60.00Hz           |      |
| 06-05 | P.30             | Regenerative brake function selection                   | 0: If regenerative brake duty is fixed at 3%, parameter 06-06(P.70) will be invalid.                   | 0                 | 110  |
|       |                  |   | 1: The regenerative brake duty is the value of 06-06(P.70).  |                   |      |
| 06-06 | P.70             | Special regenerative brake duty                         | 0 ~ 100.0%   | 0.0%              | 110  |
| 06-08 | P.155            | Over torque detection level                             | 0 ~ 200.0%   | 0.0%              | 111  |
| 06-09 | P.156            | Over torque detection time                              | 0 ~ 60.0s  | 1.0s              | 111  |
| 06-10 | P.260            | Over torque detection selection                         | 0: The OL2 alarm is not reported after the over torque detection, and the inverter keeps running.      | 1                 | 111  |
|       |                  |   | 1: The OL2 alarm is reported after the over torque detection, and the inverter stops.                  |                   |      |
| 06-12 | P.245            | Cooling fan operation                                   | 0: The fan will be turned on when running. The fan will be turned off 30 seconds after inverter stops. | 1                 | 112  |
|       |                  |   | 1: Turning on the power will turn on the fan. When the power is turned off, the fan will be off, too.  |                   |      |

Protection parameter group06

| Group | Parameter Number | Name  | Setting Range   | Factory Value | Page |
|-------|------------------|---|---|---------------|------|
| 06-12 | P.245            | Cooling fan operation                       | 2: The fan will be turned on when the temperature of the heat sink is higher than 60°C. When it is lower than 40°C, the fan will be turned off. | 1             | 112  |
|       |                  |   | 3: The fan will be turned on when the temperature of the heat sink is higher than 60°C and it will be turned off when it is lower than 40°C.    |               |      |
| 06-17 | P.261            | Maintenance alarm function                  | 0: No maintenance alarm   | 0             | 112  |
|       |                  |   | 1 ~ 9998day: Used to set time when maintenance alarm sends out signal   |               |      |
| 06-18 | P.280            | Startup of short circuit test               | 0 : Start without detection of short circuit  | 0             | 112  |
|       |                  |   | 1 : Detection of short circuit when it is started   |               |      |
| 06-19 | P.282            | GF in the operation of the testing standard | 0 ~ 100%  | 50.0%         | 112  |
| 06-27 | P.292            | Accumulative motor operation time (minutes) | 0 ~ 1439min   | 0min          | 113  |
| 06-28 | P.293            | Accumulative motor operation time (days)    | 0 ~ 9999day   | 0day          | 113  |
| 06-29 | P.296            | Inverter electric time (minutes)            | 0 ~ 1439min   | 0min          | 113  |
| 06-30 | P.297            | Inverter electric time (day)                | 0 ~ 9999day   | 0day          | 113  |
| 06-40 | P.288            | Alarm code query                            | 0 ~ 12  | 0             | 113  |
| 06-41 | P.289            | Alarm code display                          | Read  | Read          | 113  |
| 06-42 | P.290            | Alarm message query                         | 0 ~ 12  | 0             | 113  |
| 06-43 | P.291            | Alarm message display                       | Read  | Read          | 113  |

### 5.7.1 Electronic thermal relay capacity

- ◆ The “electronic thermal relay” uses the program of the inverter to simulate a thermal relay for preventing the motor from overheating.

| Parameter    | Name                              | Factory Value     | Setting Range | Content |
|--------------|-----------------------------------|-------------------|---------------|---------|
| 06-00<br>P.9 | Electronic thermal relay capacity | According to type | 0~500.00A     |         |

 Electronic thermal relay capacity

- ◆ Please set 06-00 as the rated current of the motor at its rated frequency. The rated frequency of a squirrel-cage inductive motor made in different countries and areas is different. Please refer to the nameplate instruction on the motor.
- ◆ If 06-00=0, the electronic thermal relay is invalid.
- ◆ In case the calculated heat by the electronic thermal relay exceeds the upper limit, an alarm will go off and the operation panel screen will display  $f_{HN}$ , and the output will be stopped.

Note: 1. After the inverter is reset; the thermal accumulating record of the electronic thermal relay will be reset to zero. Please pay attention in this area.  
 2. When two or more motors are connected to the inverter, they cannot be protected by the electronic thermal relay. Install an external thermal relay for each motor.  
 3. When a special motor is employed, the electronic thermal relay is no longer valid. Install an external thermal relay for each motor.  
 4. About wiring for an external thermal relay, please refer to 03-00, 03-01, 03-03 and 03-04.

### 5.7.2 Current stalling protection

- ◆ This function monitors the output current and automatically changes the output frequency to prevent the inverter from tripping due to over current, overvoltage, etc. It can also limit the stall prevention and fast-response current limit operation during acceleration/deceleration and power/regenerative driving.

| Parameter     | Name  | Factory Value | Setting Range | Content   |
|---------------|---|---------------|---------------|---|
| 06-01<br>P.22 | Stall prevention operation level                        | 150.0%        | 0 ~ 250.0%    | ---   |
| 06-02<br>P.23 | Compensation factor at level reduction                  | 99999         | 0 ~ 200.0%    | ---   |
|               |   |               | 99999         | Stall prevention operation level is the setting value of 06-01(P.22). |
| 06-03<br>P.66 | Stall prevention operation reduction starting frequency | 50.00Hz       | 0 ~ 650.00Hz  | 50Hz system (when 00-24=1)  |
|               |   | 60.00Hz       |               | 60Hz system (when 00-24=0)  |

 Current stalling protection

- ◆ When the motor starts or target frequency is adjusted (increasing) under a heavy load, the motor speed is often unable to follow the output frequency closely. If the motor speed is lower than the output frequency, the output current will increase to improve the output torque. However, if the difference between the output frequency and the motor speed is too great, the motor torque will decrease, a phenomenon known as “stall”.

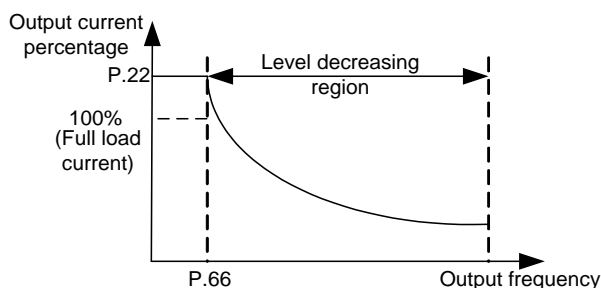

Calculation formula for stall prevention operation level:

$$\text{Level percentage} = A + B \times \frac{P.22 - A}{P.22 - B} \times \frac{P.23 - 100}{100}$$

$$A = \frac{P.66 \times P.22}{\text{Output frequency}} \quad B = \frac{P.66 \times P.22}{400}$$

### 5.7.3 Regenerative brake

- ◆ When performing frequent start and stop operation, usage rate of the regenerative brake can be increased by using the brake resistor or the brake unit.

| Parameter     | Name                                  | Factory Value | Setting Range | Content   |
|---------------|---------------------------------------|---------------|---------------|---|
| 06-05<br>P.30 | Regenerative brake function selection | 0             | 0             | If regenerative brake duty is fixed at 3%, parameter 06-06(P.70) will be invalid. |
|               |                                       |               | 1             | The regenerative brake duty is the value of 06-06(P.70).                          |
| 06-06<br>P.70 | Special regenerative brake duty       | 0.0%          | 0 ~ 100.0%    | ---   |

**Setting** Regenerative brake

- ◆ At the moment of the inverter output frequency switching from high to low, the rotation speed of the motor will be higher than the output frequency of the inverter due to load inertia, resulting in generator effect. This effect will cause a high voltage in DC bus, which will damage the inverter. Therefore, a proper brake resistor shall be mounted between terminals +/P and PR to dissipate the feedback energy.
- ◆ There is a built-in transistor inside the inverter. The conducting time ratio of the transistor is called “regenerative brake duty”. The higher the regenerative brake duty is, the more energy the brake resistor consumes, and the stronger the brake capability is.

Note: 1. In occasions where frequency starts or stops, a high capacity brake resistor is required.  
2. Please refer to Section 3.6.3 for brake resistor selection.

## 5.7.4 Over torque detection

- ◆ The output current detection function can be used for purposes such as over torque detection.

| Parameter      | Name                            | Factory Value | Setting Range | Content  |
|----------------|---------------------------------|---------------|---------------|--|
| 06-08<br>P.155 | Over torque detection level     | 0.0%          | 0             | No over torque detection.  |
|                |                                 |               | 0.1~200%      | Over torque detection.   |
| 06-09<br>P.156 | Over torque detection time      | 1.0s          | 0 ~ 60.0s     | ---  |
| 06-10<br>P.260 | Over torque detection selection | 1             | 0             | The OL2 alarm is not reported after the over torque detection, and the inverter keeps running. |
|                |                                 |               | 1             | The OL2 alarm is reported after the over torque detection, and the inverter stops.             |

### Setting Over torque detection

- ◆ When the value of 06-08 is nonzero, the function of over torque detection is selected.
- ◆ When the output current exceeds the detection level of over torque (06-08) and the detection time of over torque (06-09), then inverter alarm OL2 will go off and the inverter will stop the operation. If multi-function relay A-C (03-11) is set as over-load alarm (set the value to 3), and 06-10(P.260) =1, then the inverter will send out signals. For details, please refer to 03-10 ~03-13 in Chapter 5.

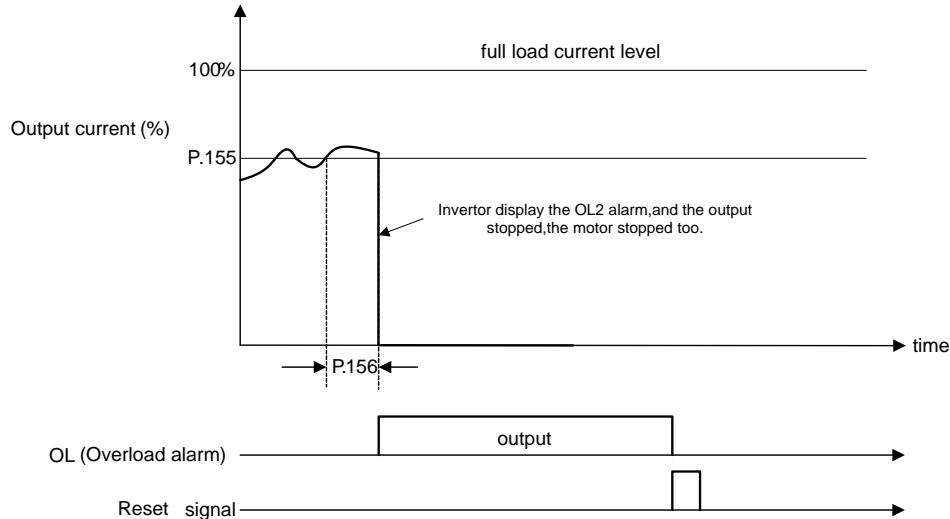

## 5.7.5 Cooling fan operation

- ◆ Control the run/stop condition of the fan and the alarm output mode.

| Parameter      | Name                  | Factory Value | Setting Range | Content  |
|----------------|-----------------------|---------------|---------------|--|
| 06-12<br>P.245 | Cooling fan operation | 1             | 0             | The fan will be turned on when running. The fan will be turned off 30 seconds after inverter stops.  |
|                |                       |               | 1             | Turning on the power will turn on the fan. When the power is turned off, the fan will be off, too.   |
|                |                       |               | 2             | The fan will be turned on when the temperature of the heat sink is higher than 60°C. When it is lower than 40°C, the fan will be turned off. |
|                |                       |               | 3             | The fan will be turned on when the temperature of the heat sink is higher than 60°C and it will be turned off when it is lower than 40°C.    |

Note: Proper setting for decreasing the fan operating time according to the inverter installing condition can extend the fan lifetime.

## 5.7.6 Maintenance alarm function

- ◆ The inverter cumulative operating time outputs the maintenance alarm output signal after setting the time.

| Parameter      | Name                       | Factory Value | Setting Range | Content  |
|----------------|----------------------------|---------------|---------------|--|
| 06-17<br>P.261 | Maintenance alarm function | 0             | 0             | No maintenance alarm                                     |
|                |                            |               | 1 ~ 9998day   | Used to set time when maintenance alarm sends out signal |

 Maintenance alarm function

- ◆ When multi-function digital output terminal (03-11) equals to 18, maintenance alarm is detecting. It means that when the inverter runs for the days that reach the parameter 06-17 setting value of maintenance alarm time, the multi-function relay will send out signal.

## 5.7.7 Floor drain current protection

- ◆ Through parameter to control whether to open the floor drain current, and set up the test accurate.

| Parameter      | Name  | Factory Value | Setting Range | Content   |
|----------------|---|---------------|---------------|---|
| 06-18<br>P.280 | Startup of short circuit test               | 0             | 0             | 0 : Start without detection of short circuit      |
|                |   |               | 1             | 1 : Detection of short circuit when it is started |
| 06-19<br>P.282 | GF in the operation of the testing standard | 50%           | 0 ~ 100%      |   |

 Floor drain current protection

- ◆ Starts to floor drain current in the inverter input only after the start signal.
- ◆ 06-18 used to set any parameters of floor drain current when starting, in the operation of the floor drain current set

by 06-19.

- ◆ If choose the startup of floor drain current detection, detection to the output of short-circuit current, and by more than 50% of the rated current, short circuit current converter to stop output, called GF different police.
- ◆ If in frequency converter operation, the output of short-circuit current is detected, the 06-19 and short-circuit current more than one parameter set value corresponding to the current, frequency converter to stop output, called GF different police.

### 5.7.8 Time record function

- ◆ It is used to record the inverter accumulative operation time.

| Parameter      | Name  | Factory Value | Setting Range | Content |
|----------------|---|---------------|---------------|---------|
| 06-27<br>P.292 | Accumulative motor operation time (minutes) | 0 min         | 0 ~ 1439min   | ---     |
| 06-28<br>P.293 | Accumulative motor operation time (days)    | 0 day         | 0 ~ 9999day   | ---     |
| 06-29<br>P.296 | Accumulative motor power time (minutes)     | 0 min         | 0 ~ 1439min   | ---     |
| 06-30<br>P.297 | Accumulative motor power time (days)        | 0day          | 0 ~ 9999day   | ---     |

Setting Time record function

- ◆ 06-27/06-29 is about the accumulative motor operation time in minutes. The updated value cannot be modified by executing 00-02 or power shutdown. To clear the accumulated time, make 06-27=0.
- ◆ 06-28/06-30 is about the accumulative motor operation time in days. The updated value cannot be modified by executing 00-02 or power shutdown. To clear the accumulated time, make 06-28=0.

### 5.7.9 Alarm query function

- ◆ This function provides the users with information on the 12 alarm codes mentioned earlier.

| Parameter      | Name                | Factory Value | Setting Range | Content  |
|----------------|---------------------|---------------|---------------|--|
| 06-40<br>P.288 | Alarm code query    | 1             | 0 ~ 12        | The value of 06-40 (P.288), 1~12, corresponds to the abnormal codes of 06-41(P.289)'s alarm E1~E12.                              |
| 06-41<br>P.289 | Alarm code display  | Read          | Read          |  |
| 06-42<br>P.290 | Alarm code query    | 0             | 0 ~ 12        | When 06-42(P.290) =1, 06-43(P.291) corresponds to the frequency when the current alarm goes off.                                 |
| 06-43<br>P.291 | Alarm message query | 0             | ---           | When 06-42(P.290) =2, 06-43(P.291) corresponds to the current when the current alarm goes off.                                   |
|                |                     |               |               | When 06-42(P.290) =3, 06-43(P.291) corresponds to the output voltage when the current alarm goes off.                            |
|                |                     |               |               | When 06-42(P.290) =4, 06-43(P.291) corresponds to the accumulation rate of temperature increase when the current alarm goes off. |
|                |                     |               |               | When 06-42(P.290) =5, 06-43(P.291) corresponds to the DC bus voltage when the current alarm goes off.                            |
|                |                     |               |               | When 06-42(P.290) =6, 06-43(P.291) corresponds to the running time when the current alarm goes off.                              |

| Parameter      | Name                | Factory Value | Setting Range | Content   |
|----------------|---------------------|---------------|---------------|---|
| 06-43<br>P.291 | Alarm message query | 0             | ---           | <p>When 06-42(P.290) =7, 06-43(P.291) corresponds to the frequency when the alarm goes off once before.</p> <p>When 06-42(P.290) =8, 06-43(P.291) corresponds to the current when the alarm goes off once before.</p> <p>When 06-42(P.290) =9, 06-43(P.291) corresponds to the output voltage when the alarm goes off once before.</p> <p>When 06-42(P.290) =10, 06-43(P.291) corresponds to the accumulation rate of temperature increase when the alarm goes off once before.</p> <p>When 06-42(P.290) =11, 06-43(P.291) corresponds to the DC bus voltage when alarm goes off once before.</p> <p>When 06-42(P.290) =12, 06-43(P.291) corresponds to the running time when the alarm goes off once before.</p> |

**Setting** Alarm query function

- ◆ This paragraph provides the users with parameter-related information on alarm codes for frequency, current, voltage, as well as the 12 alarm codes and 2 alarm codes recently mentioned earlier. If 00-02 operation is executed, the abnormal codes and the status messages for the occurred alarms recorded by this set of parameters will be all cleared.
- ◆ If both 06-40 and 06-42 are 0, 06-41 and 06-43 will be displayed as 0.
- ◆ Abnormal code corresponded alarm condition:

| Abnormal code | Alarm type | Abnormal code | Alarm type | Abnormal code | Alarm type | Abnormal code | Alarm type | Abnormal code | Alarm type |
|---------------|------------|---------------|------------|---------------|------------|---------------|------------|---------------|------------|
| 00            | No alarm   | 32            | OV1        | 49            | THN        | 98            | OL2        | 193           | CPR        |
| 16            | OC1        | 33            | OV2        | 50            | NTC        | 129           | AErr       |               |            |
| 17            | OC2        | 34            | OV3        | 64            | EEP        | 144           | OHT        |               |            |
| 18            | OC3        | 35            | OV0        | 66            | PIDE       | 160           | OPT        |               |            |
| 19            | OC0        | 48            | THT        | 97            | OLS        | 192           | CPU        |               |            |

## 5.8 Communication parameter group 07

| Group | Parameter Number | Name                                     | Setting Range  | Factory Value | Page |
|-------|------------------|--|--|---------------|------|
| 07-00 | P.33             | Communication protocol selection         | 0: Modbus protocol   | 1             | 116  |
|       |                  |  | 1: Shihlin protocol  |               |      |
| 07-01 | P.36             | Inverter station number                  | 0 ~ 254  | 0             | 116  |
| 07-02 | P.32             | Serial communication Baud rate selection | 0: Baud rate:4800bps   | 1             | 116  |
|       |                  |  | 1: Baud rate:9600bps   |               |      |
|       |                  |  | 2: Baud rate:19200bps  |               |      |
|       |                  |  | 3: Baud rate:38400bps  |               |      |
|       |                  |  | 4: Baud rate:57600bps  |               |      |
|       |                  |  | 5: Baud rate:115200bps   |               |      |
| 07-03 | P.48             | Data length                              | 0: 8bit  | 0             | 116  |
|       |                  |  | 1: 7bit  |               |      |
| 07-04 | P.49             | Stop bit length                          | 0: 1bit  | 0             | 116  |
|       |                  |  | 1: 2bit  |               |      |
| 07-05 | P.50             | Parity check selection                   | 0: No parity verification  | 0             | 116  |
|       |                  |  | 1: Odd   |               |      |
|       |                  |  | 2: Even  |               |      |
| 07-06 | P.51             | CR/LFselection                           | 1: CR only   | 1             | 116  |
|       |                  |  | 2: Both CR and LF  |               |      |
| 07-07 | P.154            | Modbus communication format              | 0: 1, 7, N, 2 (Modbus, ASCII)  | 4             | 116  |
|       |                  |  | 1: 1, 7, E, 1 (Modbus, ASCII)  |               |      |
|       |                  |  | 2: 1, 7, O, 1 (Modbus, ASCII)  |               |      |
|       |                  |  | 3: 1, 8, N, 2 (Modbus, RTU)  |               |      |
|       |                  |  | 4: 1, 8, E, 1 (Modbus, RTU)  |               |      |
|       |                  |  | 5: 1, 8, O, 1 (Modbus, RTU)  |               |      |
| 07-08 | P.52             | Number of communication retries          | 0 ~ 10   | 1             | 116  |
| 07-09 | P.53             | Communication check time interval        | 0 ~ 999.8s: Use the set value for the communication overtime test.   | 99999         | 116  |
|       |                  |  | 99999: No communication overtime test.                               |               |      |
| 07-10 | P.153            | Communication error handling             | 0: Warn and call to stop   | 0             | 116  |
|       |                  |  | 1: No warning and keep running                                       |               |      |
| 07-11 | P.34             | CommunicationEEPROM writing selection    | 0: Write parameters in communication mode, write into RAM and EEPROM | 0             | 132  |
|       |                  |  | 1: Write parameters in communication mode, write intoonly RAM        |               |      |

## 5.8.1 Shihlin protocol and Modbus protocol

- ◆ Parameter settings and monitoring are possible by using the inverter RS-485 terminals and the position machine link communication.

| Parameter      | Name                                     | Factory Value | Setting Range | Content   |
|----------------|--|---------------|---------------|---|
| 07-00<br>P.33  | Communication protocol selection         | 1             | 0             | Modbus protocol   |
|                |  |               | 1             | Shihlin protocol  |
| 07-01<br>P.36  | Inverter station number                  | 0             | 0 ~ 254       | The number of inverters is practically determined by the wiring method and impedance matching. If Modbus protocol is used, please set the value to a nonzero value. |
| 07-02<br>P.32  | Serial communication Baud rate selection | 1             | 0             | Baud rate:4800bps   |
|                |  |               | 1             | Baud rate:9600bps   |
|                |  |               | 2             | Baud rate:19200bps  |
|                |  |               | 3             | Baud rate:38400bps  |
|                |  |               | 4             | Baud rate:57600bps  |
|                |  |               | 5             | Baud rate:115200bps   |
| 07-03<br>P.48  | Data length                              | 0             | 0             | 8bit  |
|                |  |               | 1             | 7bit  |
| 07-04<br>P.49  | Stop bit length                          | 0             | 0             | 1bit  |
|                |  |               | 1             | 2bit  |
| 07-05<br>P.50  | Parity check selection                   | 0             | 0             | No parity verification  |
|                |  |               | 1             | Odd   |
|                |  |               | 2             | Even  |
| 07-06<br>P.51  | CR/LFselection                           | 1             | 1             | CR only   |
|                |  |               | 2             | Both CR and LF  |
| 07-07<br>P.154 | Modbus communication format              | 4             | 0             | 1, 7, N, 2 (Modbus, ASCII)  |
|                |  |               | 1             | 1, 7, E, 1 (Modbus, ASCII)  |
|                |  |               | 2             | 1, 7, O, 1 (Modbus, ASCII)  |
|                |  |               | 3             | 1, 8, N, 2 (Modbus, RTU)  |
|                |  |               | 4             | 1, 8, E, 1 (Modbus, RTU)  |
|                |  |               | 5             | 1, 8, O, 1 (Modbus, RTU)  |
| 07-08<br>P.52  | Number of communication retries          | 1             | 0 ~ 10        | If the frequency of communication error exceeds the setting value of 07-08(P.52), and 07-10(P.153) is set to 0, the alarm will go off and display OPT.              |
| 07-09<br>P.53  | Communication check time interval        | 99999         | 0 ~ 999.8s    | Use the set value for the communication overtime test.  |
|                |  |               | 99999         | No communication overtime test.   |
| 07-10<br>P.153 | Communication error handling             | 0             | 0             | Warn and call to stop   |
|                |  |               | 1             | No warning and keep running   |

Setting Shihlin protocol and Modbus protocol

- ◆ When the communication parameters are revised, please reset the inverter.
- ◆ The SC3 inverters have two communication protocols for selection, namely, Shihlin protocol and Modbus protocol. Parameter 07-02, 07-01, 07-08, 07-09 and 07-10 are suitable for both protocols. 07-03~07-06 is only suitable for the Shihlin protocol, while 07-07 is only suitable for the Modbus protocol. Please refer to communication protocols for more details.

Note: 1. The number of inverters is practically determined by the wiring method and impedance matching. If Modbus protocol is used, please set the value to a nonzero value.  
 2. If the frequency of communication error exceeds the setting value of 07-08(P.52), and 07-10(P.153) is set to 0, the alarm will go off and display OPT.  
 3. Modbus protocol. Displayed according to the starting bit, the data bit, parity check bit, and the stop bit. N: no parity check. E: 1-bit parity check. O: 1-bit odd parity check.

✓ SC3 RS-485 Communication interface constituents and wiring

1. SC3 RS-485 communication interface terminal arrangement

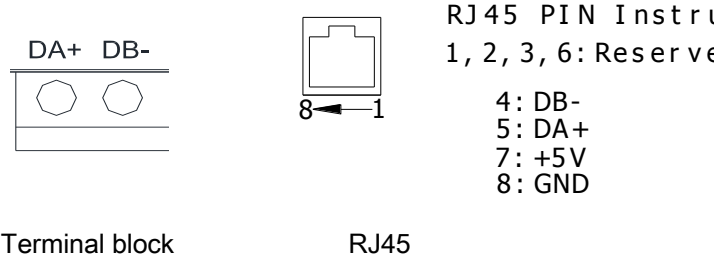

2. Communication between the position machine and single inverter (take PLC as an example).

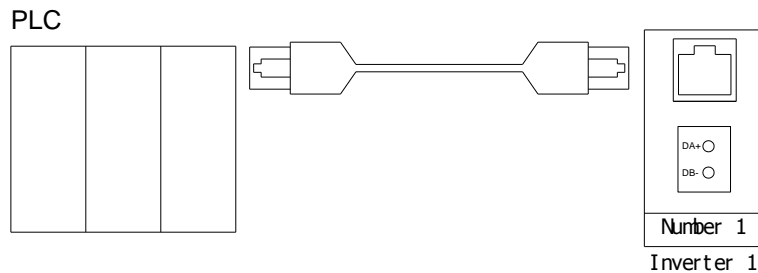

3. Communication between the position machine and multiple inverters (take PLC as an example).

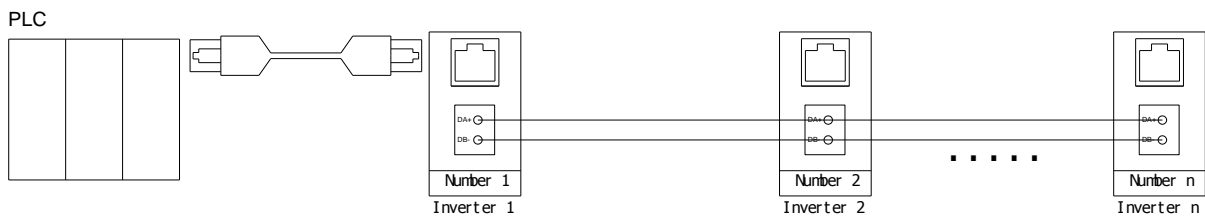

4. SC3 series inverters support Shihlin communication protocol and MODBUS communication protocol.

✓ Shihlin communication protocol

1. Automatically switch the position machine and the inverter to ASCII codes (hexadecimal) for communication.
2. Please follow the following steps for data communication between the position machine and the inverter.

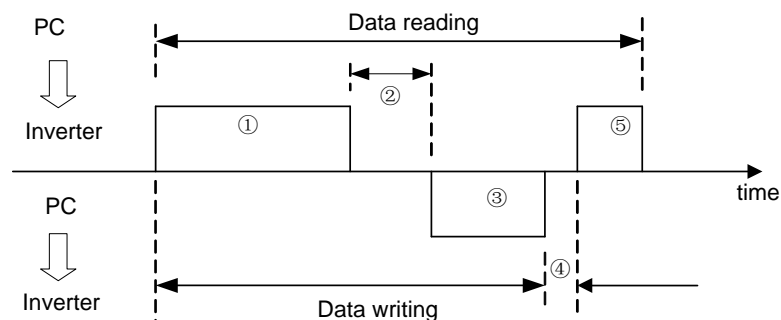

## Communication parameter group07

The above steps concerning communication actions and communication data format are explained below:

| No. | Action content   | Operation reference               | Frequency write-in | Parameter write-in | Inverter reset | Monitoring | Parameters Read-out |   |
|-----|--|-----------------------------------|--------------------|--------------------|----------------|------------|---------------------|---|
| ①   | Use the position machine's user procedure to send communication request to the inverter. | A                                 | A                  | A                  | A              | B          | B                   |   |
| ②   | Inverter data processing time  | Yes                               | Yes                | Yes                | No             | Yes        | Yes                 |   |
| ③   | Inverter's replay data (check data ① error)  | No error(Accept the request)      | C                  | C                  | C              | No         | E                   | E |
|     |  | Error exists (Refuse the request) | D                  | D                  | D              | No         | D                   | D |
| ④   | Position machine's processing delay time   | No                                | No                 | No                 | No             | No         | No                  |   |
| ⑤   | Reply from the position machine regarding reply data ③ (Check data ③ error)              | No error (No processing)          | No                 | No                 | No             | No         | C                   | C |
|     |  | Error exists (Output ③)           | No                 | No                 | No             | No         | F                   | F |

①Data of the communication request sent by the position machine to the inverter.

| Format               | Data number |                         |   |                |                  |   |                         |   |              |    |                         |    |               |    |
|----------------------|-------------|-------------------------|---|----------------|------------------|---|-------------------------|---|--------------|----|-------------------------|----|---------------|----|
|                      | 1           | 2                       | 3 | 4              | 5                | 6 | 7                       | 8 | 9            | 10 | 11                      | 12 | 13            | 14 |
| A<br>(Data write-in) | ENQ *1)     | Inverter station number |   | Reference code | Waiting time *2) |   | Data                    |   |              |    | Check code Sum check*7) |    | End symbol*3) |    |
| B<br>(Data read-out) | ENQ *1)     | Inverter station number |   | Reference code | Waiting time *2) |   | Check code Sum check*7) |   | Endsymbol*3) |    |                         |    |               |    |

③Inverter reply data

Data write-in

| Format             | Data number |   |                         |   |               |   |               |  |
|--------------------|-------------|---|-------------------------|---|---------------|---|---------------|--|
|                    | 1           | 2 | 3                       | 4 | 5             | 6 |               |  |
| C(No data error)   | ACK*1)      |   | Inverter station number |   | End symbol*3) |   |               |  |
| D(With data error) | NAK*1)      |   | Inverter station number |   | Error code*5) |   | End symbol*3) |  |

Data read-out

| Format             | Data number |                         |   |                |                |   |   |          |     |                         |    |                |    |
|--------------------|-------------|-------------------------|---|----------------|----------------|---|---|----------|-----|-------------------------|----|----------------|----|
|                    | 1           | 2                       | 3 | 4              | 5              | 6 | 7 | 8        | 9   | 10                      | 11 | 12             | 13 |
| E(No data error)   | STX*1)      | Inverter station number |   | Data read-out  |                |   |   | Unit *4) | ETX | Check code Sum check*7) |    | End symbol *3) |    |
| D(With data error) | NAK*1)      | Inverter station number |   | Error code *5) | End symbol *3) |   |   |          |     |                         |    |                |    |

⑤Reply data from the position machine to the inverter during data read-out.

| Format             | Data number |   |                         |   |                |
|--------------------|-------------|---|-------------------------|---|----------------|
|                    | 1           | 2 | 3                       | 4 | 5              |
| C(No data error)   | ACK*1)      |   | Inverter station number |   | End symbol *3) |
| F(With data error) | NAK*1)      |   | Inverter station number |   | End symbol *3) |

## \*1) Control code

| Signal | ASCIICode | Content                        | Signal | ASCIICode | Content                           |
|--------|-----------|--------------------------------|--------|-----------|-----------------------------------|
| NUL    | H00       | NULL(Empty)                    | ACK    | H06       | Acknowledge(No data error)        |
| STX    | H02       | Start of Text(Data begin)      | LF     | H0A       | Line Feed(Change line)            |
| ETX    | H03       | End of Text(Data end)          | CR     | H0D       | Carriage Return                   |
| ENQ    | H05       | Enquiry(Communication request) | NAK    | H15       | Negative Acknowledge(Data errors) |

\*2) Set the waiting time from 0 to 15 with a 10ms unit. Example: 5 --->50ms.

## \*3) End symbol (CR, LF codes)

When carrying out data communication from the position machine to the inverter, CR and LF codes at the end of the text are automatically set according to method of the position machine. At this time, the inverter has to be set according to the position machine, too. If only CR is selected, only one register will be occupied; if both CR and LF are selected, two registers will be occupied.

\*4) Unit: 0---> Unit 1, 1---> Unit 0.1, 2---> Unit 0.01, 3---> Unit 0.001

## \*5) Error code:

| Error code | Error item                   | Communication error and abnormality   |
|------------|------------------------------|---|
| H01        | Error                        | The parity check of the data received by the inverter is different from the parity check set initially.   |
| H02        | Sum Check Error              | The Sum Check calculated by the inverter according to the received data is different from the received Sum Check.   |
| H03        | Communication protocol error | The syntax of the data received by the inverter has errors. The data is not completely received during the assigned period of time. CR and LF codes are different from the initial setting. |
| H04        | Frame error                  | The stop bit of the data received by the inverter does not match to the stop bit set initially.   |
| H05        | Overflow error               | When the inverter is receiving data, the position machine sends the next set of data before the inverter finishes receiving the current one.  |
| H0A        | Abnormal mode                | The running inverter or the operation of the inverter disqualifies the requirements of the mode setting.  |
| H0B        | Reference code error         | The user assigns a reference code that cannot be processed by the inverter.   |
| H0C        | Data range error             | When setting the parameters and frequencies, the set values are outside the set range of the data.  |

\*6) When the parameter has the characteristics of 99999, the write-in or read-out of 99999 will be replaced by HFFFF.

## \*7) Request the sum check code

The converted ASCII codes of the data are summed up in binary digit format. The lower bits (the lower eight bits) of the result (the sum) converted into ASCII binary digits (hexadecimal) are termed as the Sum Check Code.

✓ Communication example:

Example 1. The position machine sends a forward rotation reference to the inverter:

Step 1: Use the position machine to send a FA reference in Format A:

| ENQ | Inverter station number | Reference code | Waiting time | Data            | Check code Sum Check | CR  |
|-----|-------------------------|----------------|--------------|-----------------|----------------------|-----|
|     | 0                       | HFA            |              | H0002           |                      |     |
| H05 | H30 H30                 | H46 H41        | H30          | H30 H30 H30 H32 | H44 H39              | H0D |

Sum Check calculation is:  $H30 + H30 + H46 + H41 + H30 + H30 + H30 + H30 + H32 = H1D9$ , take the lower eight bits D9 to convert to ASCII code H44 and H39.

Communication parameter group07

Step 2: After receiving and processing the data without error, the inverter will send a reply to the position machine in Format C:

|     |                              |     |
|-----|------------------------------|-----|
| ACK | Inverter station number<br>0 | CR  |
| H06 | H30 H30                      | H0D |

Example 2. The position machine sends a stop rotation reference to the inverter:

Step 1: Use the position machine to send a FA reference in Format A:

|     |                              |                       |              |                 |                         |     |
|-----|------------------------------|-----------------------|--------------|-----------------|-------------------------|-----|
| ENQ | Inverter station number<br>0 | Reference code<br>HFA | Waiting time | Data<br>H0000   | Check code<br>Sum Check | CR  |
| H05 | H30 H30                      | H46 H41               | H30          | H30 H30 H30 H30 | H44 H37                 | H0D |

Step 2: After receiving and processing the data without error, the inverter will send a reply to the position machine in Format C:

|     |                              |     |
|-----|------------------------------|-----|
| ACK | Inverter station number<br>0 | CR  |
| H06 | H30 H30                      | H0D |

Example 3. The read-out value of the position machine 04-07(P.142):

Step1: The position machine sends the write-in page break reference to the inverter using Format A:

|     |                              |                       |              |                 |                         |     |
|-----|------------------------------|-----------------------|--------------|-----------------|-------------------------|-----|
| ENQ | Inverter station number<br>0 | Reference code<br>HFF | Waiting time | Data<br>H0001   | Check code<br>Sum Check | CR  |
| H05 | H30 H30                      | H46 H46               | H30          | H30 H30 H30 H31 | H44 H44                 | H0D |



04-07(P.142) is on page 1

Step 2: After receiving and processing the data without error, the inverter will send a reply to the position machine in Format C:

|     |                              |     |
|-----|------------------------------|-----|
| ACK | Inverter station number<br>0 | CR  |
| H06 | H30 H30                      | H0D |

Step 3: The position machine requests the inverter for reading the value 04-07(P.142) using Format B:

|     |                              |                       |              |                         |     |
|-----|------------------------------|-----------------------|--------------|-------------------------|-----|
| ENQ | Inverter station number<br>0 | Reference code<br>H2A | Waiting time | Check code<br>Sum Check | CR  |
| H05 | H30 H30                      | H32 H41               | H30          | H30 H33                 | H0D |



First 142 minus 100 equals to 42, then convert 42 to H2A hexadecimal digits. Next convert 2 and A into H32 and H41, respectively, in ASCII code.

Step 4: Once the inverter receives and processes the data without error, the value of 04-07(P.142) will be sent to the position machine in Format E:

|     |                              |                              |      |     |                         |     |
|-----|------------------------------|------------------------------|------|-----|-------------------------|-----|
| STX | Inverter station number<br>0 | Read-out data<br>H1770(60Hz) | Unit | ETX | Check code<br>Sum Check | CR  |
| H02 | H30 H30                      | H31 H37 H37 H30              | H32  | H03 | H36 H31                 | H0D |

Example 4. Change the content of 04-07(P.142) to 50 (the original factory setting is 0).

Step 1 to 2: Omitted (Same as Step 1 to 2 of Example 3);

Step 3: The position machine requests the inverter to write 50 in 04-07(P.142) in Format A:

|     |                              |                       |              |                 |                         |     |
|-----|------------------------------|-----------------------|--------------|-----------------|-------------------------|-----|
| ENQ | Inverter station number<br>0 | Reference code<br>HAA | Waiting time | Data<br>H1388   | Check code<br>Sum Check | CR  |
| H05 | H30 H30                      | H41 H41               | H30          | H31 H33 H38 H38 | H45 H36                 | H0D |

First, 142 minus 100 equals to 42;  
Concert 42 to H2A hexadecimal digits,  
H2A+H80=HAA

because the smallest unit of 04-07(P.142) is 0.01,  
50 x 100 = 5000; then convert 5000 to hexadecimal  
digits H13888; Then covert 1, 3, 8 and 8 to ASCII  
codes for transmission.

Step 4: After receiving and processing the data without error, the inverter will send a reply to the position machine in Format C:

|     |                              |     |
|-----|------------------------------|-----|
| ACK | Inverter station number<br>0 | CR  |
| H06 | H30 H30                      | H0D |

Example 5. Write 655 into 04-07(P.142) (this parameter range is set from 0 to 650)

Step 1 to 2: Omitted (same as Step 1 and 2 of Example 3);

Step 3: The position machine requests the inverter to write 655 into 04-07(P.142) in Format A:

|     |                              |                       |              |                |           |     |
|-----|------------------------------|-----------------------|--------------|----------------|-----------|-----|
| ENQ | Inverter station number<br>0 | Reference code<br>HAA | Waiting time | Data<br>HFFDC  | SUM CHECK | CR  |
| H05 | H30 H30                      | H41 H41               | H30          | H46 H46 H44H43 | H32H35    | H0D |

Step 4: After the inverter receives and processes the information, because the data exceed the set range of 04-07(P.142), the data range is incorrect. The inverter will reply the error to the position machine in Format D:

|     |                              |                   |     |
|-----|------------------------------|-------------------|-----|
| NAK | Inverter station number<br>0 | Error code<br>H0C | CR  |
| H15 | H30 H30                      | H43               | H0D |

Note: Examples above adopt P mode to read and write parameter 04-07(P.142), if Parameter group mode is needed, please notice the differences on pages and parameter number. Please refer to the list of communication references.

## Communication parameter group07

- ✓ MODBUS communication protocol
- ✓ Message format

MODBUS serial transmission can be divided into two types: ASCII (American Standard Code for Information Interchange) and RTU (Remote Terminal Unit).

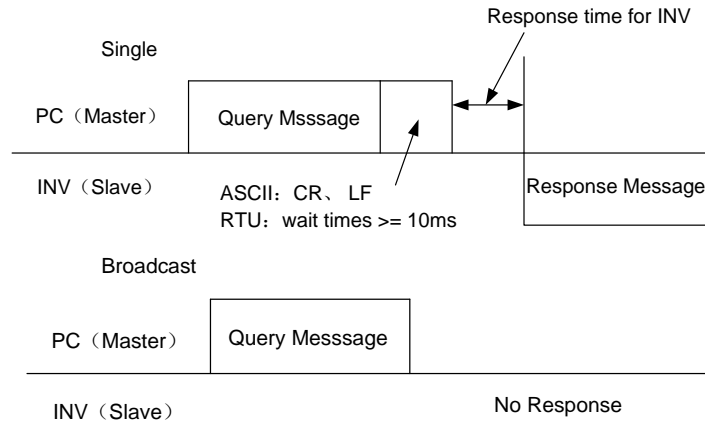

### (1) Query

Position machine (main address) sends messages to the inverter of the assigned address (from the address).

### (2) Normal Response

After receiving the query from the Master, the Slave will execute the requested function and ask the Master to send the normal response.

### (3) Error Response

When receiving invalid function codes, address or data, the inverter will send the response to the Master.

### (4) Broadcast

The Master will assign the address 0, and the slave will send the message to all the Slaves. Once receiving a message from the Master, all the Slaves will execute the requested function without responding to the Master.

- ✓ Communication format:

Basically, the Master will send Query Message to the inverter, which will send the response message to the Master. The address and function codes are duplicated for regular communication. Bit 7 of functional code during abnormal communication is positioned as "1" (=H80). The data byte is set to be the error code.

- ✓ Message constituents:

| Format | Start  | ①Address | ②Function | ③Data   | ④Error check | Stop   |
|--------|--------|----------|-----------|---------|--------------|--------|
| ASCII  | H3A    | 8bits    | 8bits     | n×8bits | 2×8bits      | 0D 0A  |
| RTU    | >=10ms |          |           |         |              | >=10ms |

| Message               | Content   |
|-----------------------|---|
| ①Address message set  | Setting range: 0~254.0 is the broadcasting address; 1~254 are the equipment (inverter) address. The setup of 07-01 is based on the equipment address. The set up is carried out when the main equipment sends messages to the equipment and when the equipment sends reply message to the main equipment.   |
| ②Function message set | Only three functions have been done so far. The equipment carries out actions according to the request from the equipment. The main equipment sets functional codes excluded from the table below. The equipment returns error response. It is determined by the response from the equipment; regular function codes are the response for regular responses; H80 + function codes are the response for error responses. |

| Message                  | Content   |   |   |                      |                         |     |   |                       |     |  |                    |     |   |                          |     |   |
|--------------------------|---|---|---|----------------------|-------------------------|-----|---|-----------------------|-----|--|--------------------|-----|---|--------------------------|-----|---|
| ②Function message set    | <table border="1"> <thead> <tr> <th>Function name</th> <th>Function code</th> <th>Function description</th> </tr> </thead> <tbody> <tr> <td>Read multiple registers</td> <td>H03</td> <td>Read slave machine's continuous register content.</td> </tr> <tr> <td>Write single register</td> <td>H06</td> <td>Write data into slave machine's single register.</td> </tr> <tr> <td>Function diagnosis</td> <td>H08</td> <td>Function diagnosis (only for communication calibration)</td> </tr> <tr> <td>Write multiple registers</td> <td>H10</td> <td>Write data into slave machine's multiple registers.</td> </tr> </tbody> </table> | Function name                                       | Function code   | Function description | Read multiple registers | H03 | Read slave machine's continuous register content. | Write single register | H06 | Write data into slave machine's single register. | Function diagnosis | H08 | Function diagnosis (only for communication calibration) | Write multiple registers | H10 | Write data into slave machine's multiple registers. |
|                          | Function name   | Function code                                       | Function description                                    |                      |                         |     |   |                       |     |  |                    |     |   |                          |     |   |
|                          | Read multiple registers   | H03   | Read slave machine's continuous register content.       |                      |                         |     |   |                       |     |  |                    |     |   |                          |     |   |
|                          | Write single register   | H06   | Write data into slave machine's single register.        |                      |                         |     |   |                       |     |  |                    |     |   |                          |     |   |
|                          | Function diagnosis  | H08   | Function diagnosis (only for communication calibration) |                      |                         |     |   |                       |     |  |                    |     |   |                          |     |   |
| Write multiple registers | H10   | Write data into slave machine's multiple registers. |   |                      |                         |     |   |                       |     |  |                    |     |   |                          |     |   |
| ③Data message set        | Changes, including the starting address, the number of the write-in or read-out registers, and the write-in data, are made according to the function codes.   |   |   |                      |                         |     |   |                       |     |  |                    |     |   |                          |     |   |
| ④Error check message set | ASCII is the check method for LRC, while RTU is the check method for CRC.   |   |   |                      |                         |     |   |                       |     |  |                    |     |   |                          |     |   |

#### ASCII mode's LRC check value calculation:

LRC check is simpler and it is used in the ASCII mode for checking the content of the message domain, excluding the colon at the beginning and the line change enter symbol at the end. It only sums up all the data to be transmitted according to the bite (not the ASCII code). If the result is greater than H100 of the hexadecimal digit, remove the exceeded part (e.g., if the result is H136 of the hexadecimal digit, then take H36 only) and add one.

#### RTU mode, CRC check value calculation:

- 1 . Add one hexadecimal digit register. All the digits are 1.
- 2 . Carry out XOR calculation for the higher bit of the hexadecimal digit register and the eight bits. The calculated result is entered to the hexadecimal digit register.
- 3 . Shift this hexadecimal digit register one bit to the right.
- 4 . If the right shifted bit (the marked bit) is 1, then polynomial 101000000000001 and this register will carry out the XOR calculation. If the right shifted bit is 0, then it will return to 3.
- 5 . Repeat 3 and 4 until 8 bits are shifted.
- 6 . The other eight bits and the hexadecimal register carry out the XOR calculation.
- 7 . Repeat 3~6 until all the bytes of the text carry out the XOR calculation with the hexadecimal register and was shifted for eight times.
- 8 . The hexadecimal register content is the 2-byte CRC error checking, and it is added to the highest valid bit of the text. When CRC is added to the message, lower bytes are added first, followed by the higher bytes.

#### ✓ Communication format:

##### 1. Data read-out (H03)

| Mode  | Start  | Address*1) | Function*2) | Start Address*3) | Number of register*4) | Check | Stop   |
|-------|--------|------------|-------------|------------------|-----------------------|-------|--------|
| ASCII | H3A    | 2char      | 2char       | 4char            | 4char                 | 2char | 0D 0A  |
| RTU   | >=10ms | 8bit       | 8bit        | 2byte            | 2byte                 | 2byte | >=10ms |

Regular response

| Mode  | Start  | Address*1) | Function*2) | Read-out data number *5) | Read-out data*6) |            | Check | Stop   |
|-------|--------|------------|-------------|--------------------------|------------------|------------|-------|--------|
| ASCII | H3A    | 2char      | 2char       | 2char                    | 4char            | ...2N×8bit | 2char | 0D 0A  |
| RTU   | >=10ms | 8bit       | 8bit        | 1byte                    | 2byte            | ...N×8bit  | 2byte | >=10ms |

| Message                      | Content  |
|------------------------------|--|
| *1)Address                   | Set up the address for the to-be delivered message; 0 for invalid.               |
| *2)Function code             | H03  |
| *3)Starting address          | Set up the address of the register for reading the message.                      |
| *4)Number of register        | Set up the number of register for reading. Maximum number: 20.                   |
| *5)Amount of data to be read | Twice the amount of *4)  |
| *6)Data to-be read           | Set the data for *4); the data will be read according to the descending sequence |

2. Data write-in (H06)

| Mode  | Start  | Address*1) | Function*2) | Start Address*3) | Write-in data*4) | Check | Stop   |
|-------|--------|------------|-------------|------------------|------------------|-------|--------|
| ASCII | H3A    | 2char      | 2char       | 4char            | 4char            | 2char | 0D 0A  |
| RTU   | >=10ms | 8bit       | 8bit        | 2byte            | 2byte            | 2byte | >=10ms |

Regular response

| Mode  | Start  | Address*1) | Function*2) | Start Address*3) | Write-in data*4) | Check | Stop   |
|-------|--------|------------|-------------|------------------|------------------|-------|--------|
| ASCII | H3A    | 2char      | 2char       | 4char            | 4char            | 2char | 0D 0A  |
| RTU   | >=10ms | 8bit       | 8bit        | 2byte            | 2byte            | 2byte | >=10ms |

| Message             | Content   |
|---------------------|---|
| *1)Address          | Set up the address for the to-be delivered message.                                 |
| *2)Function code    | H06   |
| *3)Starting address | Set up the starting address of the register to be engaged in the write-in function. |
| *4)Write-in data    | Write the data in the assigned register. The data have to be 16bit (fixed).         |

Note: Regular response content and the inquired message are the same.

3. Write multiple registers (H10)

| Mode  | Start  | Address*1) | Function*2) | Start Address*3) | Number of register *4) | Data*5) | Write-in data *6) |            | Check | Stop   |
|-------|--------|------------|-------------|------------------|------------------------|---------|-------------------|------------|-------|--------|
| ASCII | H3A    | 2char      | 2char       | 4char            | 4char                  | 2char   | 4char             | ...2N×8bit | 2char | 0D 0A  |
| RTU   | >=10ms | 8bit       | 8bit        | 2byte            | 2byte                  | 1byte   | 2byte             | ...N×16bit | 2byte | >=10ms |

Regular response

| Mode  | Start  | Address*1) | Function*2) | Start Address*3) | Number of register *4) | Check | Stop   |
|-------|--------|------------|-------------|------------------|------------------------|-------|--------|
| ASCII | H3A    | 2char      | 2char       | 4char            | 4char                  | 2char | 0D 0A  |
| RTU   | >=10ms | 8bit       | 8bit        | 2byte            | 2byte                  | 2byte | >=10ms |

| Message               | Content   |
|-----------------------|---|
| *1)Address            | Set up the address for the to-be delivered message.   |
| *2)Function code      | H10   |
| *3)Starting address   | Set up the starting address of the register to be engaged in the write-in function.   |
| *4)Number of register | Set up the number of register for reading. Maximum number: 20.  |
| *5) Amount of data    | The range should be 2 ~ 24. Set Twice the amount of *4).  |
| *6)Write-in data      | Set the assigned data in *4), write the data according to the sequence of the Hi byte and the Lo byte and the data of the starting address: According to the order of the data of the starting address +1, data of the starting address +2..., etc. |

#### 4. Function Diagnosis (H08)

By sending query information and getting the same query information back (the function of the subroutine code H00), it can do communication calibration.

The subroutine code H00 (for inquiring the return of data)

##### The query information

| Mode  | Start  | Address*1) | Function*2) | Subroutine *3) | Data *4) | Check | End    |
|-------|--------|------------|-------------|----------------|----------|-------|--------|
| ASCII | H3A    | 2char      | 2char       | 4char          | 4char    | 2char | 0D 0A  |
| RTU   | >=10ms | 1byte      | 1byte       | 2byte          | 2byte    | 2byte | >=10ms |

##### Normal response

| Mode  | Start  | Address*1) | Function*2) | Subroutine *3) | Data *4) | Check | End    |
|-------|--------|------------|-------------|----------------|----------|-------|--------|
| ASCII | H3A    | 2char      | 2char       | 4char          | 4char    | 2char | 0D 0A  |
| RTU   | >=10ms | 1byte      | 1byte       | 2byte          | 2byte    | 2byte | >=10ms |

##### Setting of the query information

| Message            | Content  |
|--------------------|--|
| *1)Address         | Set the address for the information to be sent to, not able to radio communications(0 invalid) |
| *2)Function code   | H08  |
| *3)Subroutine code | H0000  |
| *4)Data            | If the data is 2 byte, it can be set arbitrarily. Set range from H0000 to HFFFF.               |

#### 5. Error response

Carry out error response according to the error in the function, address and data of the query message received by the equipment.

There will be no errors if one or more addresses can be operated when they are accessed by the function code H03 or H10.

| Mode  | Start  | Address*1) | Function*2)<br>H80+function | Error code * 3) | Check | End    |
|-------|--------|------------|-----------------------------|-----------------|-------|--------|
| ASCII | H3A    | 2char      | 2char                       | 2char           | 2char | 0D 0A  |
| RTU   | >=10ms | 8bit       | 8bit                        | 8bit            | 2byte | >=10ms |

| Message           | Content   |
|-------------------|---|
| *1) Address       | Set up the address for the to-be delivered message. |
| *2) Function code | The function code set for the main equipment + H80  |
| *3)Error code     | Set the codes listed in the table below.            |

The list of error codes:

| Source      | Code | Meaning               | Remarks  |
|-------------|------|-----------------------|--|
| Slave reply | H01  | Invalid function code | Set up function codes that cannot be handled by the equipment in the query message sent by the main equipment. Function codes that are not H03, H06, H08 and H10 (temporarily).  |
|             | H02  | Invalid data address  | Set up addresses that cannot be handled by the equipment in the query message sent by the main equipment (Asides from the addresses listed in the address table of the register; preserve the parameters, prohibit parameter reading, prohibit parameter writing). |
|             | H03  | Invalid data value    | Set up data that cannot be handled by the equipment in the query message sent by the main equipment (parameters written outside the range, exist assigned mode, other errors, etc.)  |

Note: When performing multi-parameter reading, reading a preserved parameter is not a mistake.

Data sent to the main equipment will be tested by the inverter for the following mistakes, but the inverter will make no response for any detected error.

The list of the error test items:

| Error item     | Error content  |
|----------------|--|
| Parity error   | The parity test for data received by the inverter is different from the parity test set at the initial stage.                                |
| Frame error    | The stop byte of the data received by the inverter mismatches the stop byte set at the initial stage.  |
| Overflow error | When the inverter is receiving data, the position machine sends the next set of data before the inverter finishes receiving the current one. |
| Error test     | The LRC/CRC calculated by the inverter according to the received data is different from the received LRC/CRC.                                |

✓ Communication example:

Example 1. The operation mode written by the communication is the CU (communication) mode.

Step 1: The position machine modifies the mode of the inverter.

| Mode  | Starting | Address | Function | Starting address |         | Write-in data |         | Check   | Stop   |
|-------|----------|---------|----------|------------------|---------|---------------|---------|---------|--------|
| ASCII | H3A      | H30 H31 | H30 H36  | H31H30           | H30 H30 | H30 H30       | H30 H30 | H45 H39 | 0D 0A  |
| RTU   | >=10ms   | 01      | 06       | 10               | 00      | 00            | 00      | 8D 0A   | >=10ms |

Step 2: After receiving and processing the data without error, the inverter will send a reply to the position machine:

| Mode  | Starting | Address | Function | Starting address |         | Write-in data |         | Check   | Stop   |
|-------|----------|---------|----------|------------------|---------|---------------|---------|---------|--------|
| ASCII | H3A      | H30 H31 | H30 H36  | H31H30           | H30 H30 | H30 H30       | H30 H30 | H45 H39 | 0D 0A  |
| RTU   | >=10ms   | 01      | 06       | 10               | 00      | 00            | 00      | 8D 0A   | >=10ms |

Example 2. Read the parameter 04-07(P.142) value by the position machine

Step 1: The position machine sends message to the inverter for reading the value of 04-07(P.142).The address of 04-07(P.142) is H008E.

| Mode  | Starting | Address | Function | Starting address |         | Number of registers |         | Check   | Stop   |
|-------|----------|---------|----------|------------------|---------|---------------------|---------|---------|--------|
| ASCII | H3A      | H30 H31 | H30 H33  | H30H30           | H38 H45 | H30 H30             | H30 H31 | H36 H44 | 0D 0A  |
| RTU   | >=10ms   | 01      | 03       | 00               | 8E      | 00                  | 01      | E4 21   | >=10ms |

Step 2: Once the message is received and processed without mistake, the inverter will send the content of 04-07(P.142) to the position machine.

| Mode  | Starting | Address | Function | Number of data read | Read-out data |         | Check   | Stop   |
|-------|----------|---------|----------|---------------------|---------------|---------|---------|--------|
| ASCII | H3A      | H30 H31 | H30 H33  | H30 H32             | H31 H37       | H37 H30 | H37 H33 | 0D 0A  |
| RTU   | >=10ms   | 01      | 03       | 02                  | 17            | 70      | B6 50   | >=10ms |

Because the decimal form of H1770 is 6000 and the unit of 04-07(P.142) is 0.01, 04-07(P.142) is 60 (6000 x 0.01 = 60).

Example 3. Change the content of 04-07(P.142) to 50.

Step 1: The position machine sends message to the inverter for writing 50 into 04-07(P.142).

| Mode  | Starting | Address | Function | Starting address |         | Write-in data |         | Check   | Stop   |
|-------|----------|---------|----------|------------------|---------|---------------|---------|---------|--------|
| ASCII | H3A      | H30 H31 | H30 H36  | H30H30           | H38 H45 | H31 H33       | H38 H38 | H44 H30 | 0D 0A  |
| RTU   | >=10ms   | 01      | 06       | 00               | 8E      | 13            | 88      | E4 B7   | >=10ms |

Step 2: After receiving and processing the data without error, the inverter will send a reply to the position machine:

| Mode  | Starting | Address | Function | Starting address |         | Write-in data |         | Check   | Stop   |
|-------|----------|---------|----------|------------------|---------|---------------|---------|---------|--------|
| ASCII | H3A      | H30 H31 | H30 H36  | H30H30           | H38 H45 | H31 H33       | H38 H38 | H44 H30 | 0D 0A  |
| RTU   | >=10ms   | 01      | 06       | 00               | 8E      | 13            | 88      | E4 B7   | >=10ms |

Example 4. Read the values of parameters 01-10(P.0), 01-00(P.1), 01-01(P.2), 01-03(P.3),

04-00~04-02/P.4~P.6, 01-06~01-07/P.7~P.8, 06-00(P.9), 10-00~10-01/P.10~P.11 by the position machine.

Step 1: The position machine sends message to the inverter for reading the value of 01-10(P.0), 01-00(P.1),

01-01(P.2), 01-03(P.3), 04-00~04-02/P.4~P.6, 01-06~01-07/P.7~P.8, 06-00(P.9), 10-00~10-01/P.10~P.11.

Starting address is H0000.

| Mode  | Starting | Address | Function | Starting address |         | Number of registers |         | Check   | Stop   |
|-------|----------|---------|----------|------------------|---------|---------------------|---------|---------|--------|
| ASCII | H3A      | H30 H31 | H30 H33  | H30H30           | H30 H30 | H30 H30             | H30 H43 | H46 H30 | 0D 0A  |
| RTU   | >=10ms   | 01      | 03       | 00               | 00      | 00                  | 0C      | 45 CF   | >=10ms |

Step 2: After receiving and processing the data without error, the inverter will send a reply to the position machine:

| Mode  | Starting | Address | Function | Number of data read | Read-out data | Check | Stop   |
|-------|----------|---------|----------|---------------------|---------------|-------|--------|
| ASCII | H3A      | H30 H31 | H30 H33  | H31 H38             | ...12x4 char  | 2char | 0D 0A  |
| RTU   | >=10ms   | 01      | 03       | 18                  | ...12x2 byte  | 2byte | >=10ms |

Example 5. Rewrite the values of parameters 01-10(P.0), 01-00(P.1), 01-01(P.2), 01-03(P.3), 04-00~04-02/P.4~P.6,

01-06~01-07/P.7~P.8, 06-00(P.9), 10-00~10-01/P.10~P.11 by the inverter

Step 1: The position machine sends message to the inverter for writing the value of 01-10(P.0), 01-00(P.1),

01-01(P.2), 01-03(P.3), 04-00~04-02/P.4~P.6, 01-06~01-07/P.7~P.8, 06-00(P.9),

10-00~10-01/P.10~P.11.

| Mode  | Starting | Address | Function | Starting address |         | Number of registers | Data volume | Write-in data | Check      | Stop  |        |
|-------|----------|---------|----------|------------------|---------|---------------------|-------------|---------------|------------|-------|--------|
| ASCII | H3A      | H30 H31 | H31 H30  | H30 H30          | H30 H30 | H30 H30             | H31 H38     | ...Nx4 char   | 2char      | 0D 0A |        |
| RTU   | >=10ms   | 01      | 10       | 00               | 00      | 00                  | 0C          | 18            | ...Nx2byte | 2byte | >=10ms |

Step 2: After receiving and processing the data without error, the inverter will send a reply to the position machine:

| Mode  | Starting | Address | Function | Starting address |         | Number of registers | Check   | Stop    |        |
|-------|----------|---------|----------|------------------|---------|---------------------|---------|---------|--------|
| ASCII | H3A      | H30 H31 | H31 H30  | H30H30           | H30 H30 | H30 H30             | H30 H43 | H45 H33 | 0D 0A  |
| RTU   | >=10ms   | 01      | 10       | 00               | 00      | 00                  | 0C      | 00 18   | >=10ms |

Note: Examples above adopt P mode to read and write parameter 04-07(P.142), if Parameter Group mode is needed, please notice the differences on address. Please refer to the list of communication references.

Communication parameter group07

◆ The list of communication references

The following references and data are set for carrying out assorted operation control and monitoring.

| Item                                     |        | Shihlin protocol reference code | Modbus reference code | Modbus address | Data content and function description  |        |    |    |    |    |                |     |     |     |     |
|--|--------|---------------------------------|-----------------------|----------------|--|--------|----|----|----|----|----------------|-----|-----|-----|-----|
| Operation mode read-out                  |        | H7B                             | H03                   | H1000          | H0000: communication mode;<br>H0001: external mode;<br>H0002: JOG Mode;<br>H0003: combination mode 1;<br>H0004: combination mode 2;<br>H0005: combination mode 3;<br>H0006: combination mode 4;<br>H0007: combination mode 5;<br>H0008: PUMode;  |        |    |    |    |    |                |     |     |     |     |
| Operation mode write-in                  |        | HFB                             | H06/H10               |                |  |        |    |    |    |    |                |     |     |     |     |
| Inverter status monitoring               |        | H7A                             | H03                   | H1001          | H0000~H00FF<br>b15: during tuning<br>b14:during inverter resetting<br>b13, b12: Reserved<br>b11:inverter E0 status<br>b10: Reserved<br>b9: Reserved<br>b8: Reserved<br>b7: abnormality occurred<br>b6: frequency test<br>b5: End parameters to restore the default values<br>b4: overloaded<br>b3: reached the frequency<br>b2: during reverse rotation<br>b1: during forward rotation<br>b0: during rotation  |        |    |    |    |    |                |     |     |     |     |
| Target frequency write-in                | EEPROM | HEE                             | H06/H10               | H1009          | H0000~ HFDE8: 0~650Hz  |        |    |    |    |    |                |     |     |     |     |
|  | RAM    | HED                             |                       | H1002          |  |        |    |    |    |    |                |     |     |     |     |
| Special monitor select codes read out    |        | H7D                             | H03                   | H1013          | H0000~H0010: monitor selected information.<br>Special monitor select read out codes as described in the special monitoring code table (H0009 is reserved)  |        |    |    |    |    |                |     |     |     |     |
| Special monitor select codes write in    |        | HF3                             | H06/H10               |                |  |        |    |    |    |    |                |     |     |     |     |
| Monitor the external operation condition |        | H7C                             | H03                   | H1012          | H0000~H000F: <table border="1" style="display: inline-table; vertical-align: middle;"><tr><td style="text-align: center;">b15-b4</td><td style="text-align: center;">b3</td><td style="text-align: center;">b2</td><td style="text-align: center;">b1</td><td style="text-align: center;">b0</td></tr><tr><td style="text-align: center;">0000 0000 0000</td><td style="text-align: center;">MRS</td><td style="text-align: center;">STR</td><td style="text-align: center;">STF</td><td style="text-align: center;">RES</td></tr></table> | b15-b4 | b3 | b2 | b1 | b0 | 0000 0000 0000 | MRS | STR | STF | RES |
| b15-b4                                   | b3     | b2                              | b1                    | b0             |  |        |    |    |    |    |                |     |     |     |     |
| 0000 0000 0000                           | MRS    | STR                             | STF                   | RES            |  |        |    |    |    |    |                |     |     |     |     |
| Inverter reset                           |        | HFD                             | H06/H10               | H1101          | H9696: function of 00-02=2/P.997=1.<br>When communicating with the position machine, resetting the inverter will cause the inverter to be incapable of sending data back to the position machine.  |        |    |    |    |    |                |     |     |     |     |

| Item                           | Shihlin protocol reference code | Modbus reference code | Modbus address   | Data content and function description  |  |
|--------------------------------|---------------------------------|-----------------------|--|--|--|
| Parameter delete               | HFC                             | H06/<br>H10           | H1104  | H5A5A  | For details, please refer to the parameter restoration status table. |
|                                |                                 |                       |  | H5566  |  |
|                                |                                 |                       |  | H5959  |  |
|                                |                                 |                       | H1103  | H9966  |  |
|                                |                                 |                       | H1106  | H9696  |  |
|                                |                                 |                       |  | H99AA  |  |
|                                |                                 |                       |  | H9A9A  |  |
| H1105                          | H55AA                           |                       |  |  |  |
| H1102                          | HA5A5                           |                       |  |  |  |
| Parameter read-out             | H00~H63                         | H03                   | P mode:<br>H0000~<br>H0141<br><br>Parameter group mode:<br>H2710~<br>H2CFF | <ol style="list-style-type: none"> <li>The data range and the position of the decimal point, please refer to the parameter table.</li> <li>In P mode, the Modbus address of each parameter corresponds to the hexadecimal digit of the parameter number. For example, the Modbus address of 04-26(P.138) is H008A.</li> <li>In parameter group mode, the Modbus address of each parameter corresponds to the parameter number+ the hexadecimal digit of 10000, such as the Modbus address of 04-26(P.138) is 0x28BA.</li> </ol>  |  |
| Parameter write-in             | H80~HE3                         | H06/<br>H10           |  |  |  |
| Operation reference write-in   | HFA                             | H06/<br>H10           | H1001  | H0000~HFFFF<br>b8~b15: reserved.<br>b7: inverter emergency stop (MRS)<br>b6: the second function (RT)<br>b5: high speed (RH)<br>b4: medium speed (RM)<br>b3: low speed (RL)<br>b2: reverse rotation (STR)<br>b1: forward rotation (STF)<br>b0: reserved.   |  |
| Monitor the INV real-time data | ---                             | H03                   | H1014~H1026  | The corresponding monitoring value of each Modbus address is as follows:<br>H1014: digital input terminal input state.<br>H1015: digital input terminal output state.<br>H1016: Reserved.<br>H1017: 3-5 terminal input current/voltage<br>H1018: Reserved.<br>H1019: DC bus voltage<br>H101A: the electronic thermal accumulation rate of inverter<br>H101B: inverter output power<br>H101C: the temperature rising accumulation rate of inverter<br>H101D: the NTC temperature accumulation of inverter<br>H101E: the electronic thermal accumulation rate of motor<br>H101F: target pressure when PID control<br>H1020: feedback pressure when PID control |  |

| Item   |                  | Shihlin protocol reference code | Modbus reference code | Modbus address | Data content and function description  |  |              |              |              |              |
|--|------------------|---------------------------------|-----------------------|----------------|--|--|--------------|--------------|--------------|--------------|
| Page change for parameter reading and writing<br>Page change for parameter reading and writing | Read             | H7F                             | ---                   | ---            | P mode:<br>H0000: P.0~P.99;<br>H0001: P.100~P.199;<br>H0002: P.200~P.299;<br>H0003: P.300~P.399;<br>H0004: P.400~P.499;<br>Parameter group mode:<br>H0064: 00-00~00-99;<br>H0065: 01-00~01-99;<br>H0066: 02-00~02-99;<br>H0067: 03-00~03-99;<br>H0068: 04-00~04-99;<br>H0069: 05-00~05-99;<br>H006A: 06-00~06-99<br>H006B: 07-00~07-99<br>H006C: 08-00~08-99<br>H006E: 10-00~10-99<br>H006F: 11-00~11-99<br>H0071: 13-00~13-99<br>H0073: 15-00~15-99 |  |              |              |              |              |
|  | Write            | HFF                             |                       |                |  |  |              |              |              |              |
| Monitoring   | Frequency setup  | EEPRM                           | H73                   | H03            | H1009  | H0000~HFDE8(two decimal points when 00-08=0; one decimal point when non-zero)  |              |              |              |              |
|  |                  | RAM                             | H6D                   |                | H1002  |  |              |              |              |              |
|  | Output frequency |                                 | H6F                   |                | H1003  | H0000~H9C40(same as above)   |              |              |              |              |
|  | Output current   |                                 | H70                   |                | H1004  | H0000~HFFFF(two decimal points)  |              |              |              |              |
|  | Output voltage   |                                 | H71                   |                | H1005  | H0000~HFFFF(two decimal points)  |              |              |              |              |
|  | Abnormal content |                                 | H74                   |                | H1007  | H0000~HFFFF: Abnormal codes from the last two times<br>H74/H1007: Error code 1 and 2;<br>b15            b8 b7            b0<br><table border="1" style="width: 100%; border-collapse: collapse;"> <tr> <td style="width: 50%; text-align: center;">Error code 2</td> <td style="width: 50%; text-align: center;">Error code 1</td> </tr> </table> H75/H1008: Error code 3 and 4;<br>b15            b8 b7            b0<br><table border="1" style="width: 100%; border-collapse: collapse;"> <tr> <td style="width: 50%; text-align: center;">Error code 4</td> <td style="width: 50%; text-align: center;">Error code 3</td> </tr> </table> For abnormal codes, please refer to the abnormal code list in the abnormal record parameter06-40~06-43. | Error code 2 | Error code 1 | Error code 4 | Error code 3 |
|  |                  |                                 | Error code 2          |                | Error code 1   |  |              |              |              |              |
| Error code 4   | Error code 3     |                                 |                       |                |  |  |              |              |              |              |
| H75  | H1008            |                                 |                       |                |  |  |              |              |              |              |

## ◆ Parameter restoration condition table

| Data content | Parameter Operation | Communication Parameter P (Note 1) | Table 1 (Note2) | Table 2 (Note2) | User registered parameter | Other P parameters | Error codes |
|--------------|---------------------|------------------------------------|-----------------|-----------------|---------------------------|--------------------|-------------|
| H5A5A        | 00-02=4(P.999=1)    | o                                  | x               | x               | o                         | o                  | x           |
| H5566        | 00-02=5(P.999=2)    | o                                  | x               | o               | x                         | o                  | x           |
| H5959        | 00-02=6(P.999=3)    | o                                  | x               | x               | x                         | o                  | x           |
| H9966        | 00-02=3(P.998=1)    | o                                  | x               | o               | o                         | o                  | x           |
| H9696        | Communication 999 1 | x                                  | x               | x               | o                         | o                  | x           |
| H99AA        | Communication 999 2 | x                                  | x               | o               | x                         | o                  | x           |
| H9A9A        | Communication 999 3 | x                                  | x               | x               | x                         | o                  | x           |
| H55AA        | Communication 998   | x                                  | x               | o               | o                         | o                  | x           |
| HA5A5        | 00-02=1(P.996=1)    | x                                  | x               | x               | x                         | x                  | o           |

Note: 1. Communication P parameters includes 07-02(P.32), 07-00(P.33), 07-01(P.36), 07-03(P.48) ~ 07-09(P.53), 00-16(P.79), 07-10(P.153) and 07-07(P.154).

2. For the table 1 and table 2, please refer to Section 5.1.2.

## ◆ The table of the special monitor code

| Information | Content   | Unit        |
|-------------|---|-------------|
| H0000       | Monitor the digital input terminal input port state.                | 注 1         |
| H0001       | Monitor the digital output terminal output port state.              | 注 2         |
| H0003       | Monitor the voltage/current which can be input across terminal 3-5. | 0.01A/0.01V |
| H0005       | Monitor the DC bus voltage value.                                   | 0.1V        |
| H0006       | Monitor the electronic thermal accumulation rate                    | ---         |
| H0007       | The temperature rising accumulation rate of inverter                | 0.01        |
| H0008       | The inverter output power   | 0.01kW      |
| H0009       | the NTC temperature accumulation of inverter                        | ---         |
| H000A       | The electronic thermal accumulation rate of motor                   | ---         |
| H000B       | Target pressure when PID control                                    | 0.1%        |
| H000C       | Feedback pressure when PID control                                  | 0.1%        |

Note: 1. Details of the digital input terminal input port state.

| b3 | b2 | b1  | b0  |
|----|----|-----|-----|
| M1 | M0 | STR | STF |

2. Details of the digital output terminal output port state.

| b1  | b0 |
|-----|----|
| A-C | 1  |

## 5.8.2 Writing Selection of Communication EEPROM

►Set it when you need to change the parameter

| Parameter     | Name  | Name | Name | Content  |
|---------------|---|------|------|--|
| 07-11<br>P.34 | Writing selection of<br>communication<br>EEPROM | 0    | 0    | Write the parameter of EEPROM , RAM through communication. |
|               |   |      | 1    | Write the parameter of RAM through communication.          |

Setting Function of communication EEPROM write selection.

- ◆ Writing the parameter the RS-485 terminal of the inverter, you can change the by parameter storage device form EEPROMtoRAM.
- ◆ If you want to change parameter frequently, please make the setting value of 07-11(P.34) communication EEPROM writing selection as1.But it you set it as 0, the EEPROM lifewill. If the setting the value of EEPROM data writing is 0, the life of EEPROM will be shortened by frequent EEPROM data writing.

Note : If 07-11(P.34) =1(only RAM data writing), If the inverter is power off, the parameter will be lost when the value of 07-11(P.34) is set as 1(only RAM data writing.)

## 5.9 PID parameter group08

| Group | Parameter Number | Name  | Setting Range  | Factory Value | Page |
|-------|------------------|---|--|---------------|------|
| 08-00 | P.170            | PID function selection                        | 0: PID function non-selected   | 0             | 134  |
|       |                  |   | 1: Parameter 08-03(P.225) sets target value. Take the input of terminal 3-5 as target source |               |      |
| 08-01 | P.171            | PID feedback control method                   | 0: Negative feedback control.  | 0             | 134  |
|       |                  |   | 1: Positive feedback control.  |               |      |
| 08-03 | P.225            | PID target value panel reference              | 0 ~ 100.0%   | 20.0%         | 134  |
| 08-04 | P.172            | Proportion gain                               | 1~100  | 20            | 134  |
| 08-05 | P.173            | Integral time                                 | 0 ~ 100.0s   | 1.0s          | 134  |
| 08-06 | P.174            | Differential time                             | 0 ~ 1000ms   | 0ms           | 134  |
| 08-07 | P.175            | Abnormal deviation                            | 0 ~ 100.0%   | 0.0%          | 147  |
| 08-08 | P.176            | Exception duration time                       | 0 ~ 600.0s   | 30.0s         | 134  |
| 08-09 | P.177            | Exception handling mode                       | 0: Free stop   | 0             | 135  |
|       |                  |   | 1: Decelerate and stop   |               |      |
|       |                  |   | 2: Continue to run when the alarm goes off   |               |      |
| 08-10 | P.178            | Sleep detects deviation                       | 0 ~ 100.0%   | 0.0%          | 135  |
| 08-11 | P.179            | Sleep detects duration time                   | 0 ~ 255.0s   | 1.0s          | 135  |
| 08-12 | P.180            | Revival level                                 | 0 ~ 100.0%   | 90.0%         | 135  |
| 08-13 | P.181            | Outage level                                  | 0 ~ 120.00Hz   | 40.00Hz       | 135  |
| 08-14 | P.182            | Integral upper limit                          | 50.00Hz : 0 ~ 120.00Hz   | 50.00Hz       | 135  |
|       |                  |   | 60.00Hz : 0 ~ 120.00Hz   | 60.00Hz       |      |
| 08-15 | P.183            | Deceleration step length with stable pressure | 0 ~ 10.00Hz  | 0.50Hz        | 135  |
| 08-18 | P.223            | Analog feedback bias pressure                 | 0 ~ 100.0%   | 0.0%          | 135  |
| 08-19 | P.224            | Analog feedback gain pressure                 | 0 ~ 100.0%   | 100.0%        | 135  |

### 5.9.1 PID function selection

- ◆ Process control such as flow rate, air volume or pressure is possible on the inverter. A feedback system can be configured and PID control can be performed using the digital input signal or parameter setting value as the set point, and the digital input signal as the feedback value.

| Parameter      | Name                        | Factory Value | Setting Range | Content   |
|----------------|-----------------------------|---------------|---------------|---|
| 08-00<br>P.170 | PID function selection      | 0             | 0             | PID function non-selected   |
|                |                             |               | 2             | Parameter 08-03(P.225) sets target value, take the input of terminal 3-5 as target source |
| 08-01<br>P.171 | PID feedback control method | 0             | 0             | Negative feedback control.  |
|                |                             |               | 1             | Positive feedback control.  |

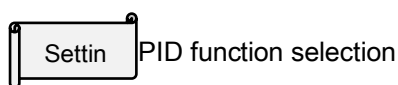

- ◆ During the operation of PID control, the frequency displayed on the screen is the output frequency of the inverter.
- ◆ For input signal filtering of terminal 3-5, please refer to the instructions for02-10.

### 5.9.2 PID parameter group

- ◆ Auto-adjusting of process control can be easily performed by user via setting PID parameter.

| Parameter      | Name                             | Factory Value | Setting Range | Content   |
|----------------|----------------------------------|---------------|---------------|---|
| 08-03<br>P.225 | PID target value panel reference | 20.0%         | 0~100.0%      | The target value is set by 08-03(P.225) when the value of 08-00(P.170) is set to 2.   |
| 08-04<br>P.172 | Proportion gain                  | 20            | 1~100         | This gain determines the proportion controller's impact on feedback deviation. The greater the gain, the faster the impact. Yet again that is too big will cause vibration.   |
| 08-05<br>P.173 | Integral time                    | 1.0s          | 0 ~ 100.0s    | This parameter is use to set integral controller's integral time. When the integral gain is too big, the integral effect will be too weak to eliminate steady deviation. When the integral gain is too small, the system vibration frequency will increase, and therefore the system may be unstable. |
| 08-06<br>P.174 | Differential time                | 0ms           | 0 ~ 10000ms   | This gain determines deviation controller's impact on the amount of change of the deviation. Appropriate deviation time can reduce the overshooting between the proportion controller and the integral controller. Yet when the deviation time is too large, system vibration may be induced.         |
| 08-07<br>P.175 | Abnormal deviation               | 0.0%          | 0 ~ 100.0%    | ---   |
| 08-08<br>P.176 | Exception duration time          | 30.0s         | 0 ~ 600.0s    | ---   |

| Parameter      | Name  | Factory Value | Setting Range | Content   |   |
|----------------|---|---------------|---------------|---|---|
| 08-09<br>P.177 | Exception handling mode                       | 0             | 0             | Free stop   |   |
|                |   |               | 1             | Decelerate and stop   |   |
|                |   |               | 2             | Continue to run when the alarm goes off   |   |
| 08-10<br>P.178 | Sleep detects deviation                       | 0.0%          | 0 ~ 100.0%    | ---   |   |
| 08-11<br>P.179 | Sleep detects duration time                   | 1.0s          | 0 ~ 255.0s    | ---   |   |
| 08-12<br>P.180 | Revival level                                 | 90.0%         | 0 ~ 100.0%    | ---   |   |
| 08-13<br>P.181 | Outage level                                  | 40.00Hz       | 0 ~ 120.00Hz  | ---   |   |
| 08-14<br>P.182 | Integral upper limit                          | 50.00Hz       | 0 ~ 120.00Hz  | 50.00Hz system  | When the deviation value accumulated with the integral time, an upper limit for deviation accumulation should be set. For example, the upper integral limit of frequency is equal to 01-03 * 08-14. |
|                |   | 60.00Hz       |               | 60.00Hz system  |   |
| 08-15<br>P.183 | Deceleration step length with stable pressure | 0.50Hz        | 0 ~ 10.00Hz   | When the feedback pressure satisfies the deviation value for stopping the machine and the set time (in seconds) for stopping the machine for detection is reached, the inverter will take the 08-15 (P.183) step to reduce the frequency. |   |
| 08-18<br>P.223 | Analog feedback bias pressure                 | 0.0%          | 0 ~ 100.0%    | Revising the feedback signal to unify the signal range of inverter's feedback terminal and actual feedback, so that the inverter display in accordance with the feedback meter.   |   |
| 08-19<br>P.224 | Analog feedback gain pressure                 | 100.0%        | 0 ~ 100.0%    |   |   |

 PID parameter group 1

- ◆ The revising instruction of the analog feedback bias pressure and gain pressure:
  1. The system default value can be used to revise without connecting with feedback signal, the default value is as follows:

| The feedback of terminal 3-5 |                     |
|------------------------------|---------------------|
| Revising current             | Revising proportion |
| 4mA                          | 08-18               |
| 20mA                         | 08-19               |

Note: 1.The range of default setting is 0.1~5V. If there is a mismatch between the default setting range and the user's range, 08-18 and 08-19 can be set and 08-00 must be set at last to unify the range.  
 2. If use 3-5 terminal as purpose source or feedback source, please must set 02-20 before, and use AVI-ACI switch, choose voltage/current as the terminal 3-5 input signal.

Example 1: When the 0~7V feedback signal is given by terminal 3-5:

- 1) When 08-01=0 (negative feedback control),  $08-18 = 0.1 / 7 * 100.0 = 1.4$   
 $08-19 = 5 / 7 * 100.0 = 71.4$
- 2) When 08-01=1 (positive feedback control),  $08-18 = (7 - 0.1) / 7 * 100.0 = 98.6$   
 $08-19 = (7 - 5) / 7 * 100.0 = 28.6$

By setting 08-18 and 08-19 as the above calculated value, and then setting 08-00 at 1, 02-00 at 4 (terminal 3-5) or 08-00 at 3, 02-02 at 4 (terminal 3-5), the revised range is 0~7V.

Example 2: When the 0~20mA feedback signal is given by terminal 3-5:

- 1) When 08-01=0 (negative feedback control),  $08-18 = 4 / 20 * 100.0 = 20.0$   
 $08-19 = 20 / 20 * 100.0 = 100.0$
- 2) When 08-01=1 (positive feedback control),  $08-18 = (20 - 4) / 20 * 100.0 = 80.0$   
 $08-19 = (20 - 20) / 20 * 100.0 = 0$

By setting 08-18 and 08-19 as the above calculated value, and then setting 08-00 at 2, 02-01 at 4, the revised range is 0~20mA.

2. When the feedback signal need to be revised by the user:

Please adjust the feedback signal to a certain value and then calculate the proportion of the value to the feedback range, then write the proportion value into 08-18.;

After that, adjust the feedback signal to a new value and then calculate the proportion of the value to the feedback range, then write the proportion value into 08-19.

Example 1: When the user's feedback range is 0~10kg,

When the feedback signal is adjusted to 4kg,  $08-18 = (4 / 10) * 100.0 = 40$ ,

When the feedback signal is adjusted to 6kg,  $08-19 = (6 / 10) * 100.0 = 60$ .

Note: The actual feedback signal must be connected and the value of 08-00 must be set before revising like this.

◆ The instruction for the target pressure given by external analog terminal:

3. When the target value is set by terminal 3-5 (02-00 = 3)  
 When 02-08 = 0, the given range is 0~5V corresponding to 0~100%;  
 When 02-08 = 1, the given range is 0~10V corresponding to 0~100%.
4. When the target value is set by terminal 3-5 (02-01 = 3)  
 The given range is 4~20mA corresponding to 0~100%.

Example: Set 08-00 = 1, 08-01 = 0.

It indicates that the PID target value is given by the current of terminal 3-5 (4~20mA).

If 8mA is given by the user, the corresponding given proportion is  $(8-4) / (20-4) * 100.0 = 25.0$

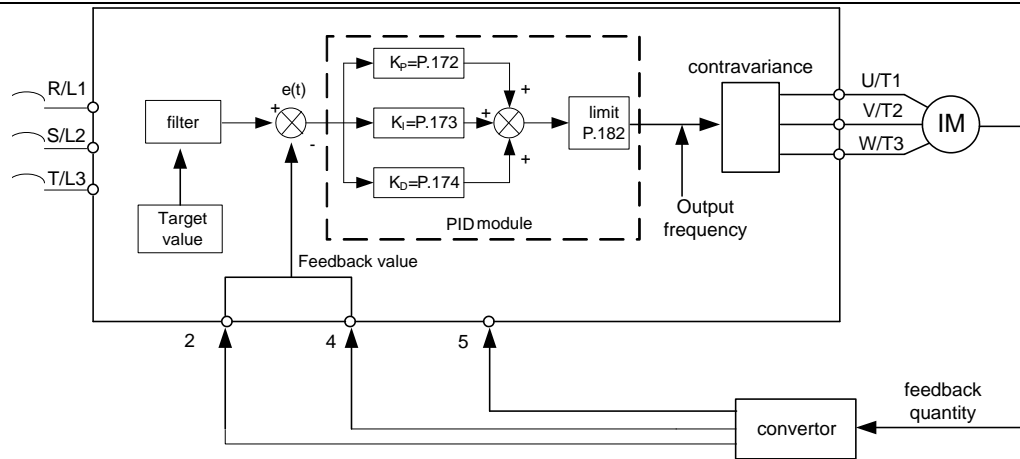

- ◆ When the output frequency reaches the value of 01-03 \* 08-14, the feedback value will be less than the product of the target value multiplying 08-07. In addition, when the duration lasts more than the set value of 08-08, PID will be considered as abnormal and handled according to the set value of 08-09.

For example, when 08-07=60%, 08-08=30s, 08-09=0, 01-03=50Hz and 08-14= 100%, the output frequency reaches 50Hz, and the feedback value is lower than 60% of the target feedback value for 30 seconds continuously, alarm will be display and the inverter will be stopped freely.

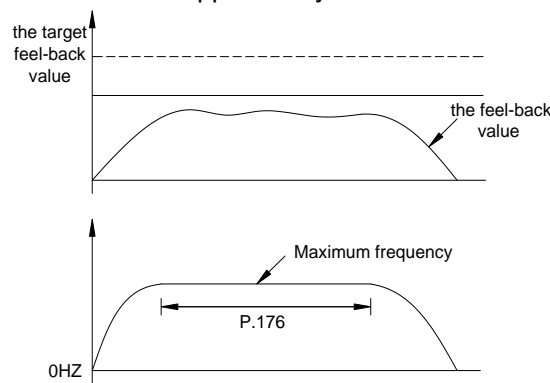

- ◆ If 08-10 is set to 0, then the set values of 08-11, 08-12, 08-13 and 08-15 are invalid. If the setting value of 08-10 is nonzero, than PID's sleep function will be activated. When the absolute value of the deviation between the feedback value and the target feedback value is less than the sleep detected deviation value for the duration of 08-11's sleep detection time, the inverter will steadily reduce the output frequency. Once the output frequency of the inverter is less than the machine stop level of 08-13, the inverter will decelerate and stop. When the feedback value is lower than the wake-up level, the output frequency of the inverter will again be controlled by PID.

For example, if 08-10=5%, 08-11=1.0s, 08-12=90%, 08-13=40Hz, and 08-15=0.5Hz, and when the feedback value is at a stable zone, i.e., larger than 95% of the target feedback value but less than 105% of the target feedback value, the inverter at the stable zone will reduce the output frequency by 0.5Hz/second. When the output frequency of the inverter is less than 40Hz, the inverter will directly decelerate and stop. When the feedback value lower than 90% of the target feedback value, the inverter will wake up and the output frequency will again be controlled by PID.

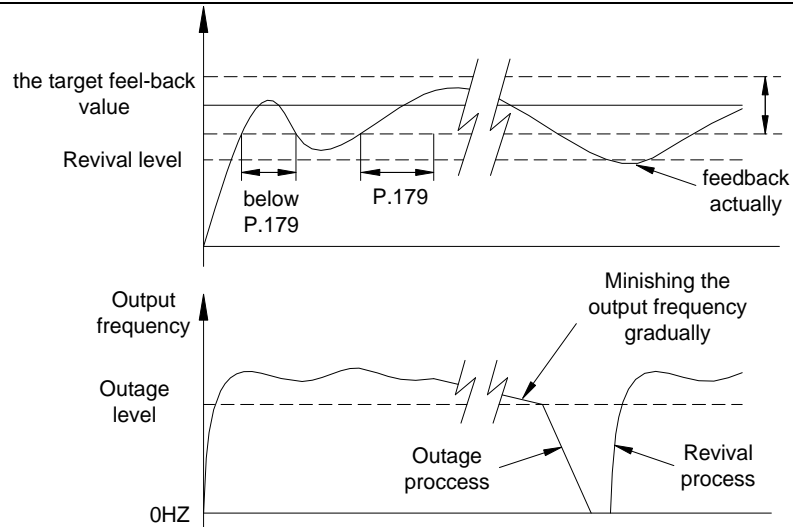

◆ PID gain simple setting:

1. After changing target, response is slow ---Increase P-gain ( $K_P = 08-04$ )  
 response is quick but unstable ---Decrease P-gain ( $K_P = 08-04$ )

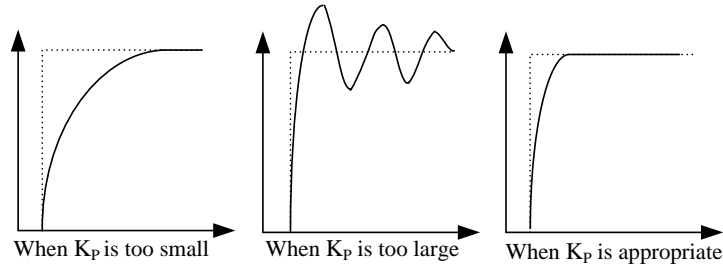

2. Target and feedback do not become equal ---Decrease Integration time ( $K_I = 08-05$ )  
 become equal after unstable vibration ---Increase Integration time ( $K_I = 08-05$ )

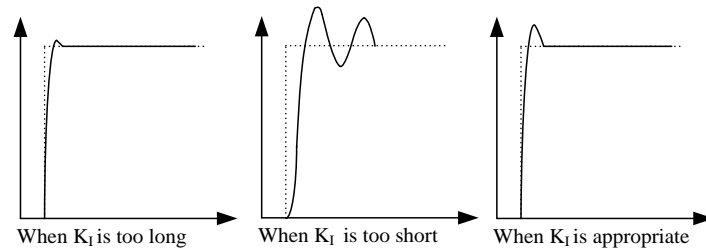

- ◆ Even after increasing  $K_P$ , response is still slow ---Increase D-gain ( $K_D = 08-06$ )  
 It is still unstable ---Decrease D-gain ( $K_D = 08-06$ )

Note: 1. When 08-09=2, the panel has no alarm display but the multi-function output terminal has alarm detection. To turn off the alarm, reset 00-02 or turn down the power.

## 5.10 Application parameter group 10

| Group | Parameter Number | Name                                     | Setting Range  | Factory Value | Page |
|-------|------------------|--|--|---------------|------|
| 10-00 | P.10             | DC injection brake operation frequency   | 0 ~ 120.00Hz   | 3.00Hz        | 142  |
| 10-01 | P.11             | DC injection brake operation time        | 0 ~ 60.0s  | 0.5s          | 142  |
| 10-02 | P.12             | DC injection brake operation voltage     | 0 ~ 30.0%  | 4.0%          | 142  |
| 10-03 | P.151            | Zero-speed control function selection    | 0: There is no output at zero-speed.<br>1: DC voltage breaking   | 0             | 143  |
| 10-04 | P.152            | Voltage at zero-speed control            | 0 ~ 30.0%  | 5.0%          | 143  |
| 10-05 | P.242            | DC injection brake function before start | 0: DC injection brake function is not available before starting.<br>1: DC brake injection function is selected before starting.  | 0             | 143  |
| 10-06 | P.243            | DC injection brake time before start     | 0 ~ 60.0s  | 0.5s          | 143  |
| 10-07 | P.244            | DC injection brake voltage before start  | 0 ~ 30.0%  | 4.0%          | 143  |
| 10-08 | P.150            | Restart mode selection                   | X0: No frequency search.<br>X1: Reserved<br>X2: Decrease voltage mode<br>0X: Power on once.<br>1X: Start each time.<br>2X: Only instantaneous stop and restart   | 0             | 144  |
| 10-09 | P.57             | Restart coasting time                    | 0 ~ 30.0s<br>99999: No restart function.   | 99999         | 144  |
| 10-10 | P.58             | Restart cushion time                     | 0 ~ 60.0s  | 10.0s         | 144  |
| 10-11 | P.61             | Remote setting function                  | 0: No remote setting function.<br>1: Remote setting function, frequency setup storage is available.<br>2: Remote setting function, frequency setup storage is not available.<br>3: Remote setting function, frequency setup storage is not available; the remote setting frequency is cleared by STF/STR "turn off". | 0             | 145  |

Application parameter group

| Group | Parameter Number | Name   | Setting Range   | Factory Value | Page |
|-------|------------------|--|---|---------------|------|
| 10-12 | P.65             | Retry selection                                | 0: Retry is invalid.  | 0             | 147  |
|       |                  |  | 1: Over-voltage occurs; the inverter will perform the retry function.                                   |               |      |
|       |                  |  | 2: Over-current occurs; the inverter will perform the retry function.                                   |               |      |
|       |                  |  | 3: Over-voltage or over-current occurs; the inverter will perform the retry function.                   |               |      |
|       |                  |  | 4: All the alarms have the retry function.  |               |      |
| 10-13 | P.67             | Number of retries at alarm occurrence          | 0: Retry is invalid.  | 0             | 147  |
|       |                  |  | 1 ~ 10: The setting value of 10-13(P.67) is exceeded; the inverter will not perform the retry function. |               |      |
| 10-14 | P.68             | Retry waiting time                             | 0 ~ 360.0s  | 6.0s          | 147  |
| 10-15 | P.69             | Retry accumulation time at alarm               | Read only   | 0             | 147  |
| 10-16 | P.119            | The dead time of positive and reverse rotation | 0 ~ 3000.0s   | 0.0s          | 148  |
| 10-17 | P.159            | Energy-saving control function                 | 0: Normal running mode.   | 0             | 148  |
|       |                  |  | 1: Energy-saving running mode.  |               |      |
| 10-18 | P.229            | Dwell function selection                       | 0: None.  | 0             | 149  |
|       |                  |  | 1: Backlash compensation function.  |               |      |
|       |                  |  | 2: Acceleration and deceleration interrupt waiting function.  |               |      |
| 10-19 | P.230            | Dwell frequency at acceleration                | 0 ~ 650.00Hz  | 1.00Hz        | 149  |
| 10-20 | P.231            | Dwell time at acceleration                     | 0 ~ 360.0s  | 0.5s          | 149  |
| 10-21 | P.232            | Dwell frequency at deceleration                | 0 ~ 650.00Hz  | 1.00Hz        | 149  |
| 10-22 | P.233            | Dwell time at deceleration                     | 0 ~ 360.0s  | 0.5s          | 149  |
| 10-23 | P.234            | Triangular wave function selection             | 0: None.  | 0             | 151  |
|       |                  |  | 1: External TRI is turned on; triangular wave function will be valid.                                   |               |      |
|       |                  |  | 2: The triangular wave function is effective at any given time.   |               |      |
| 10-24 | P.235            | Maximum amplitude                              | 0 ~ 25.0%   | 10.0%         | 151  |
| 10-25 | P.236            | Amplitude compensation for deceleration        | 0 ~ 50.0%   | 10.0%         | 151  |
| 10-26 | P.237            | Amplitude compensation for acceleration        | 0 ~ 50.0%   | 10.0%         | 151  |
| 10-27 | P.238            | Amplitude acceleration time                    | 0 ~ 360.00s/0 ~ 3600.0s   | 10.00s        | 151  |
| 10-28 | P.239            | Amplitude deceleration time                    | 0 ~ 360.00s/0 ~ 3600.0s   | 10.00s        | 151  |
| 10-55 | P.226            | Reciprocating mechanical function              | 0 : Reciprocating mechanical function is invalid  | 0             | 152  |
|       |                  |  | 1 : Reciprocating mechanical function effectively   |               |      |

## Application parameter group10

|       |       |                       |           |      |     |
|-------|-------|-----------------------|-----------|------|-----|
| 10-56 | P.227 | Forward limit of time | 0~3600.0s | 0.0s | 152 |
| 10-57 | P.228 | Reverse time limited  | 0~3600.0s | 0.0s | 152 |

### 5.10.1 DC injection brake

- ◆ Timing to stop or braking torque can be adjusted by applying DC voltage to the motor to prevent the motor shaft to turn at the time of stopping motor.

| Parameter     | Name                                   | Factory Value | Setting Range | Content |
|---------------|--|---------------|---------------|---------|
| 10-00<br>P.10 | DC injection brake operation frequency | 3.00Hz        | 0 ~ 120.00Hz  | ---     |
| 10-01<br>P.11 | DC injection brake operation time      | 0.5s          | 0 ~ 60.0s     | ---     |
| 10-02<br>P.12 | DC injection brake operation voltage   | 4.0%          | 0 ~ 30.0%     | ---     |

**Setting** DC injection brake

- ◆ After a stop signal is put in (please refer to Chapter 4 for the primary operation of motor activation and stop), the output frequency of the inverter will decrease gradually. In case the output frequency reaches the “DC injection brake operation frequency (10-00),” the DC injection brake will be activated.
- ◆ During DC injection brake, a DC voltage will be injected into the motor windings by the inverter, which is used to lock the motor rotor. This voltage is called “DC injection brake operation voltage (10-02)”. The larger the 10-02 is, the higher the DC brake voltage is, and the stronger the brake capability is.
- ◆ The DC brake operation will last a period (the set value of 10-01) to overcome the motor inertia.
- ◆ See the figure below:

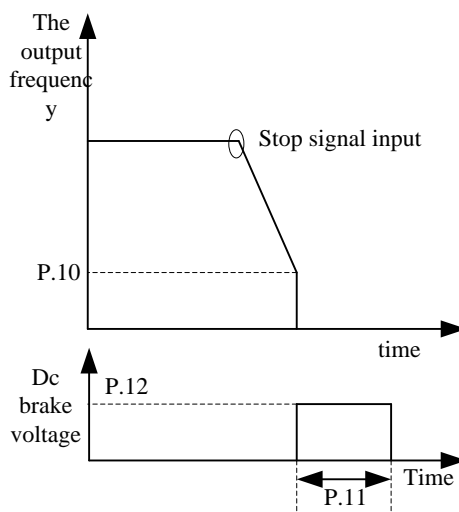

Note: 1. To achieve the optimum control characteristics, 10-01 and 10-02 should be set properly.  
 2. If any of 10-00, 10-01 and 10-02 is set to 0, DC injection brake will not operate, i.e., the motor will coast to stop.

### 5.10.2 Zero-speed/zero-servo control

#### ◆ Zero-speed/ zero-servo function selection

| Parameter      | Name                                  | Factory Value | Setting Range | Content                           |
|----------------|---------------------------------------|---------------|---------------|-----------------------------------|
| 10-03<br>P.151 | Zero-speed control function selection | 0             | 0             | There is no output at zero-speed. |
|                |                                       |               | 1             | DC voltage breaking               |
| 10-04<br>P.152 | Voltage at zero-speed control         | 5.0%          | 0 ~ 30.0%     |                                   |

Settin Zero-speed control

#### ◆ Make sure that 01-11 (start frequency) is set to zero when using this function.

Note: 1. Suppose that 10-04 = 6%, and then the output voltage of zero speed is 6% of base frequency voltage 01-04.  
2. This function is valid only in V/F mode .The setting of motor control mode can be referred to parameter 00-21(P.300).

### 5.10.3 DC injection brake before start

#### ◆ The motor may be in the rotation status due to external force or itself inertia. If the drive is used with the motor at this moment, it may cause motor damage or drive protection due to over current.

| Parameter      | Name                                     | Factory Value | Setting Range | Content   |
|----------------|--|---------------|---------------|---|
| 10-05<br>P.242 | DC injection brake function before start | 0             | 0             | DC injection brake function is not available before starting. |
|                |  |               | 1             | DC brake injection function is selected before starting.      |
| 10-06<br>P.243 | DC injection brake time before start     | 0.5s          | 0 ~ 60.0s     | ---   |
| 10-07<br>P.244 | DC injection brake voltage before start  | 4.0%          | 0 ~ 30.0%     | ----  |

Settin DC injection brake before start

#### ◆ If 10-05=0, DC injection brake function is not available before starting. If 10-05=1, DC brake injection function is selected before starting. When the output frequency reaches the starting frequency 01-11, a DC voltage (the set value of 10-07) will be injected into the motor windings by the inverter, which is used to lock the motor rotor. The DC brake operation will last a period (the set value of 10-06) before the motor starts.

See the figure below:

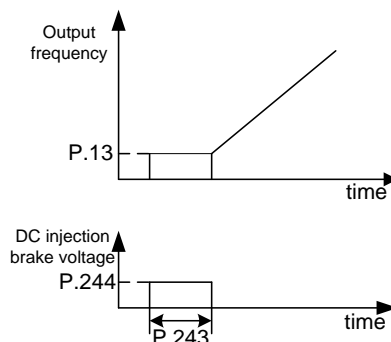

Note: This function is only valid under the V/F mode; i.e., it is effective when 00-21=0.

### 5.10.4 Restart mode selection

- ◆ Select the best start mode according to the different load.

| Parameter      | Name                   | Factory Value | Setting Range | Content                             |
|----------------|------------------------|---------------|---------------|-------------------------------------|
| 10-08<br>P.150 | Restart mode selection | 0             | X0            | No frequency search.                |
|                |                        |               | X1            | Reserved                            |
|                |                        |               | X2            | Decrease voltage mode               |
|                |                        |               | 0X            | Power on once.                      |
|                |                        |               | 1X            | Start each time.                    |
|                |                        |               | 2X            | Only instantaneous stop and restart |
| 10-09<br>P.57  | Restart coasting time  | 99999         | 0 ~ 30.0s     | ---                                 |
|                |                        |               | 99999         | No restart function.                |
| 10-10<br>P.58  | Restart rise time      | 10.0s         | 0 ~ 60.0s     |                                     |

**Settin** Restart mode selection

- ◆ There are four digits in 10-08, and the meaning of every digit is as follows:

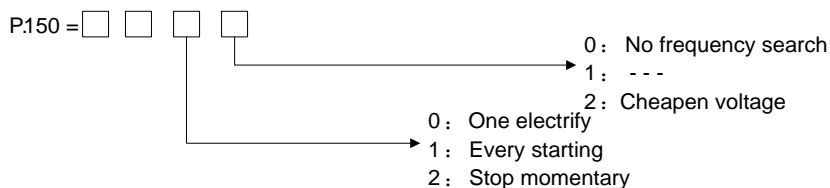

- Note:
1. When one needs an instant restart function, 10-08 must be set.
  2. When 10-08 is nonzero, linear acceleration / deceleration curve is the default.
  3. The direction detection position of 10-08 is only valid for direct frequency search.
  4. This function is only valid under the V/F mode; i.e., it is effective when 00-21=0.

**Settin** Restart

- ◆ Once the driving power is interrupted while the motor is still running, voltage output will be stopped instantly. When the power is recovered and 10-09=99999, the inverter will not restart automatically. When 10-09=0.1~30, the motor will coast for a while (the set value of 10-09) before the inverter restarts the motor automatically.
- ◆ Once the motor is restarted automatically, the output frequency of the inverter will be the target frequency, but the output voltage will be zero. Then the voltage will be increased gradually to the expected voltage value. The period for voltage increase is called "Restart rise time (10-10)".

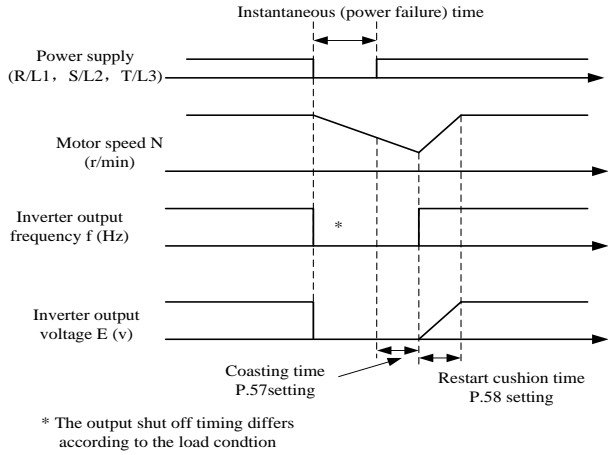

5.10.5 Remote setting function selection

- ◆ If the operation box is located away from the control box, one can use contact signals to perform variable-speed operation without using analog signals

| Parameter     | Name                              | Factory Value | Setting Range | Content   |
|---------------|-----------------------------------|---------------|---------------|---|
| 10-11<br>P.61 | Remote setting function selection | 0             | 0             | No remote setting function.   |
|               |                                   |               | 1             | Remote setting function, frequency setup storage is available.  |
|               |                                   |               | 2             | Remote setting function, frequency setup storage is not available.  |
|               |                                   |               | 3             | Remote setting function, frequency setup storage is not available; the remote setting frequency is cleared by STF/STR "turn off". |

Setting Remote setting function

- ◆ If the operation box is located away from the control box, one can use contact signals to perform variable-speed operation without using analog signals under the external mode, combined mode 1 and combined mode 5.

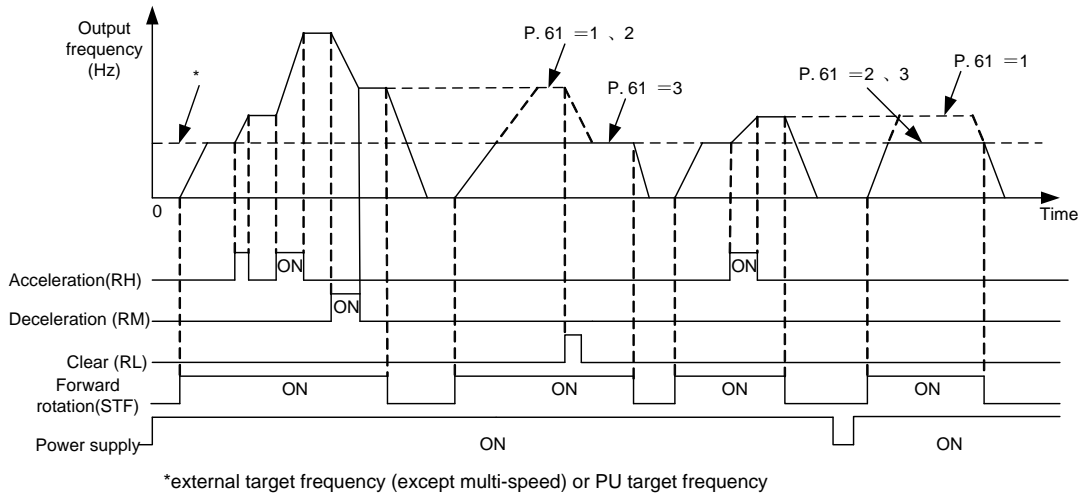

- ◆ Remote setting function



### 5.10.6 Retry selection

- ◆ This function allows the inverter to reset itself and restart at fault indication. The retry generating protective functions can be also selected.

| Parameter     | Name                                  | Factory Value | Setting Range | Content   |
|---------------|---------------------------------------|---------------|---------------|---|
| 10-12<br>P.65 | Retry selection                       | 0             | 0             | Retry is invalid.   |
|               |                                       |               | 1             | Over-voltage occurs; the inverter will perform the retry function.                              |
|               |                                       |               | 2             | Over-current occurs; the inverter will perform the retry function.                              |
|               |                                       |               | 3             | Over-voltage or over-current occurs; the inverter will perform the retry function.              |
|               |                                       |               | 4             | All the alarms have the retry function.   |
| 10-13<br>P.67 | Number of retries at alarm occurrence | 0             | 0             | Retry is invalid.   |
|               |                                       |               | 1 ~ 10        | The setting value of 10-13(P.67) is exceeded; the inverter will not perform the retry function. |
| 10-14<br>P.68 | Retry waiting time                    | 6.0s          | 0 ~ 360.0s    | ---   |
| 10-15<br>P.69 | Retry accumulation time at alarm      | 0             | Read          | ---   |

#### Setting Retry selection

- ◆ When an alarm goes off, a "retry" will take place to restore the previous setting.
- ◆ Inverter's retry is performed conditionally. When the alarm goes off and the inverter has an automatic retry, the re-occurrence of alarm going off before a set time is called a "continuous alarm". If continuous alarms happen for more than a set time, there is a significant malfunction. In this case, manual trouble shooting is necessary. The inverter at this point will perform no more the retry function. The number of Pre-defined occurrence is called "number of retries at abnormality (10-13)".
- ◆ If none of the alarm belongs to "continuous alarms", the inverter will perform retry for unlimited times.
- ◆ The period from the moment of alarm to that of retry is defined as "retry waiting time".
- ◆ For each time a retry happens, the value of 10-15 will be increased by one automatically. Therefore, the number of 10-15 read from the memory indicates the number of retries that have occurred.
- ◆ If 10-15 is rewritten with 0, the number of retry executed is cleared.

Note: The inverter will perform retry only after the retry waiting time of 10-14. Therefore when using this function, please be aware of the possible danger when operating the inverter.

### 5.10.7 The dead time of positive and reverse rotation

- ◆ Set the waiting or holding time after the output frequency outputs to 0Hz when the positive and reverse rotation is switching.

| Parameter      | Name   | Factory Value | Setting Range | Content  |
|----------------|--|---------------|---------------|--|
| 10-16<br>P.119 | The dead time of positive and reverse rotation | 0.0s          | 0             | Without the function.  |
|                |  |               | 0.1~3000.0s   | The waiting or holding time after the output frequency decreases to 0 when the positive and reverse rotation is switching. |

**Settin** The dead time of positive and reverse rotation

- ◆ When the inverter is running and receive the reverse rotation reference, the output frequency will decrease to 0 in the process of switching from the current rotation direction to the opposite rotation direction. The dead time of positive and reverse rotation is the waiting or holding time after the output frequency decreases to 0.

The diagram is as follows:

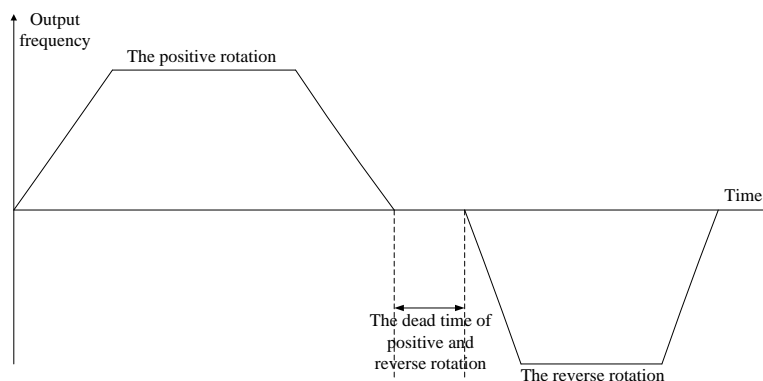

### 5.10.8 Energy-saving control function V/F

- ◆ Under the energy-saving running mode, the inverter will control the output voltage automatically in order to reduce the output power losses to the minimum when the inverter is run at a constant speed.

| Parameter      | Name                           | Factory Value | Setting Range | Content                     |
|----------------|--------------------------------|---------------|---------------|-----------------------------|
| 10-17<br>P.159 | Energy-saving control function | 0             | 0             | Normal running mode.        |
|                |                                |               | 1             | Energy-saving running mode. |

**Settin** Energy-saving mode

- ◆ Under the energy-saving running mode, the inverter will control the output voltage automatically in order to reduce the output power losses to the minimum when the inverter is run at a constant speed.

Note: 1. This function is valid only in the V/F mode(00-21="0").

2. After selecting the energy-saving running mode, the deceleration time may be longer than the setting value. In addition, the properties of the regular torque load will produce abnormal voltage more easily. Please slightly prolong the deceleration time.

3. For big load purposes or machines with frequent acceleration/deceleration, the energy-saving effect may be poor.

### 5.10.9 Dwell function V/F

- ◆ The backlash measures that stop acceleration/deceleration by the frequency or time set with parameters at acceleration/deceleration can be set.

| Parameter      | Name                            | Factory Value | Setting Range | Content   |
|----------------|---------------------------------|---------------|---------------|---|
| 10-18<br>P.229 | Dwell function selection        | 0             | 0             | None.   |
|                |                                 |               | 1             | Backlash compensation function.                           |
|                |                                 |               | 2             | Acceleration and deceleration interrupt waiting function. |
| 10-19<br>P.230 | Dwell frequency at acceleration | 1.00Hz        | 0 ~ 650.00Hz  | Set the stopping frequency and time of Dwell function.    |
| 10-20<br>P.231 | Dwell time at acceleration      | 0.5s          | 0 ~ 360.0s    |   |
| 10-21<br>P.232 | Dwell frequency at deceleration | 1.00Hz        | 0 ~ 650.00Hz  | Set the stopping frequency and time of Dwell function.    |
| 10-22<br>P.233 | Dwell time at deceleration      | 0.5s          | 0 ~ 360.0s    |   |



- ◆ Backlash compensation(10-18="1")

Reduction gears have an engagement gap and a dead zone between forward and reverse rotation. This dead zone is called backlash, and the gap disables a mechanical system from following motor rotation.

More specifically, a motor shaft develops excessive torque when the direction of rotation changes or when constant-speed operation shifts to deceleration, resulting in a sudden motor current increase or regenerative status.

To avoid backlash, acceleration/deceleration is temporarily stopped. Set the acceleration/deceleration stopping frequency and time in 10-18 ~ 10-22.

Shown as the figure below:

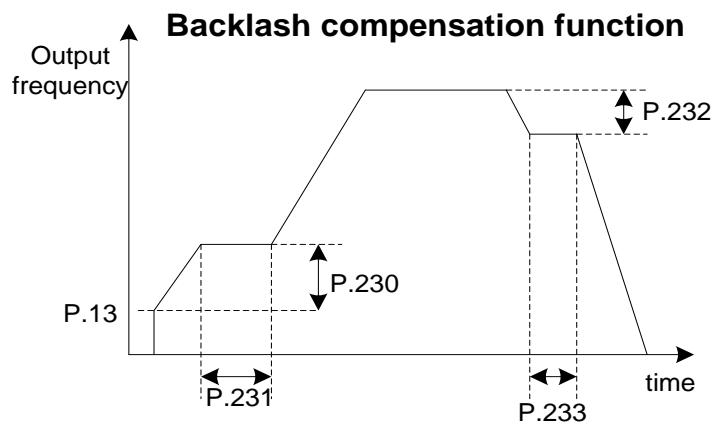

Note: The setting of the backlash compensation will only prolong the acceleration/deceleration time during the period of interruption.

◆ Acceleration and deceleration interrupt waiting function(10-18="2")

When 10-18=2, start acceleration and deceleration interrupt waiting function. When accelerating to the frequency set by 10-19, wait for the time set by 10-20 and then accelerate to the target. When decelerating to the frequency set by 10-21, wait for the time set by 10-22, and then decelerate to the target.

Shown as the figure below:

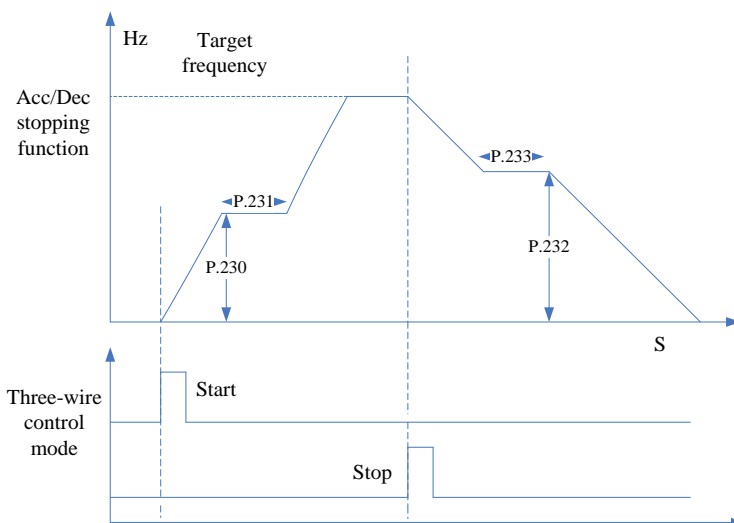

Note: The setting of the backlash compensation will only prolong the acceleration/deceleration time during the period of interruption.

## 5.10.10 Triangular wave function V/F

- ◆ The triangular wave operation, which oscillates the frequency at a constant cycle, is available.

| Parameter      | Name                                    | Factory Value | Setting Range               | Content  |
|----------------|---|---------------|-----------------------------|--|
| 10-23<br>P.234 | Triangular wave function selection      | 0             | 0                           | 0: None.   |
|                |   |               | 1                           | External TRI is turned on, triangular wave function will be valid. |
|                |   |               | 2                           | The triangular wave function is effective at any given time.       |
| 10-24<br>P.235 | Maximum amplitude                       | 10.0%         | 0 ~ 25.0%                   | ---  |
| 10-25<br>P.236 | Amplitude compensation for deceleration | 10.0%         | 0 ~ 50.0%                   | ---  |
| 10-26<br>P.237 | Amplitude compensation for acceleration | 10.0%         | 0 ~ 50.0%                   | ---  |
| 10-27<br>P.238 | Amplitude acceleration time             | 10.00s        | 0 ~ 360.00s/<br>0 ~ 3600.0s | When 01-08=0, the unit of 10-27(P.238) and 10-28(P.239) is 0.01s.  |
| 10-28<br>P.239 | Amplitude deceleration time             | 10.00s        | 0 ~ 360.00s/<br>0 ~ 3600.0s | When 01-08=1, the unit of 10-27(P.238) and 10-28(P.239) is 0.1s.   |

Settin

 Triangular wave function

- ◆ If 10-23 “Triangular wave function selection” is “1” and triangular wave operation signal (TRI) is turned on, triangular wave function will be valid. Set any parameter in 03-00, 03-01, 03-03 and 03-04 “Input terminal selection function” to “36” and then assign the TRI signal for the external terminal.
- ◆ If 10-23 “triangular wave function selection” is equal to “2,” the triangular wave function is effective at any given time.

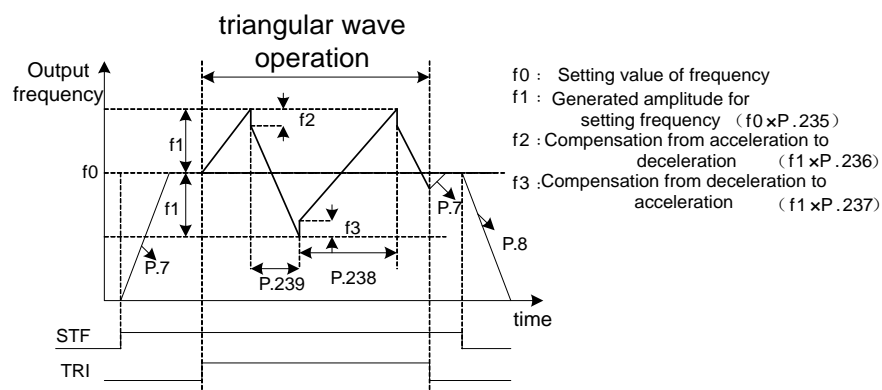

- Note: 1. During the movement of the triangular wave, the output frequency is limited by the maximum and the minimum frequency.
2. If the amplitude compensation, i.e., 10-25 and 10-26, is too big, over-voltage will be tripped off and the stall prevention action will be executed automatically. Consequently, the setting method will not be carried out.
3. This function is only valid under the V/F mode; i.e., it is effective when 00-21=0.

### 5.10.11 Reciprocating engine function

- ◆ The inverter contains control function for switching between the commercial power supply operation and inverter operations. Therefore, interlock operation of the magnetic contactor for switching can be easily performed by simply inputting start, stop, and automatic switching selection signals.

| Parameter      | Name                              | Factory Value | Setting Range | Content  |
|----------------|-----------------------------------|---------------|---------------|--|
| 10-55<br>P.226 | Reciprocating mechanical function | 0             | 0             | Reciprocating mechanical function is invalid   |
|                |                                   |               | 1             | Reciprocating mechanical function effectively  |
| 10-56<br>P.227 | Forward limit of time             | 0.0s          | 0 ~ 3600.0s   | When the inverter keeps running in FWD mode and its running time is longer than the setting value of 0.-56, the motor speed will decrease to zero and the inverter will be powered off. This function is invalid when the setting value is zero. |
| 10-57<br>P.228 | Reverse time limited              | 0.0s          | 0 ~ 3600.0s   | When the inverter keeps running in FWD mode and its running time is longer than the setting value of 10-57, the motor speed will decrease to zero and the inverter will be powered off. This function is invalid when the setting value is zero. |

Setting Reciprocating engine function

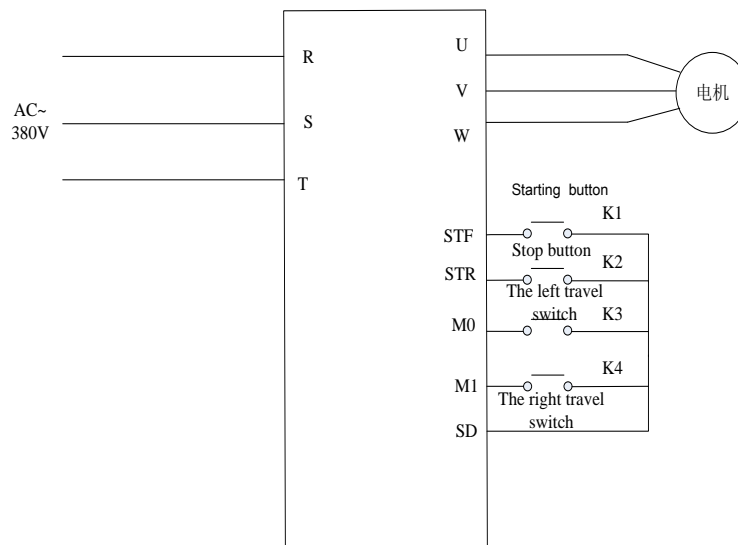

System wiring diagram

- ◆ Please connect the wire as the figure shown above. Place a travel switch between M1 and SD place impulse type switch between STF and SD and between STR and SD also.
- ◆ Power on the inverter and execute parameter P998. After finish set P226 to 1 and choose reciprocating machinery system. Set multi-functional terminator as its default value, if the target frequency was coming from external terminals, M0, M1 terminal will influence the target frequency therefore P5, P6 should be set as the same value with target frequency.
- ◆ When K3 ( K4 ) is open, press K1 and rotate forward to K3, then rotate reverse to K4 and rotate forward again. Press K2 to shut down the system.

- ◆ When K3( K4 )is closed,press K1 and rotate forward (reverse) to K4(K3),close then rotate forward (reverse) again. Press K2 to shut down the system.
- ◆ To prevent damage on travel switch, a time limitation for forward and reverse rotate was added in the system. Both travel switch are closed at the same time is prohibited. It will cause shutdown of the system.

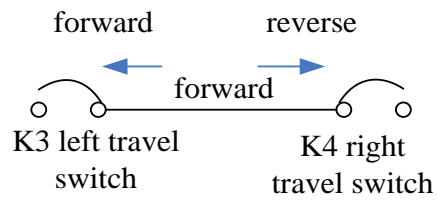

Run the process diagram

## 5.11 Speed and torque control parameter group 11

| Group | Parameter Number | Name   | Setting Range | Factory Value | Page                |
|-------|------------------|--|---------------|---------------|---------------------|
| 11-00 | P.320            | Slip compensation gain                                     | 0~200%        | 85%           | 154                 |
| 11-01 | P.321            | Torque compensation filter coefficients                    | 0 ~ 32        | 20            | 154                 |
| 11-02 | P.322            | First set of current filter cutoff frequency point of time | 0~30.00Hz     | 4.00Hz        | <a href="#">154</a> |
| 11-03 | P.323            | First set of current filtering time                        | 0~400.00ms    | 20.00ms       | <a href="#">154</a> |
| 11-04 | P.324            | Second group of current filter time at low frequency       | 0~400.00ms    | 1.00ms        | <a href="#">154</a> |
| 11-05 | P.325            | Second group of current filtering time                     | 0~400.00ms    | 36.00ms       | <a href="#">154</a> |

### 5.11.1 Control parameter

- ◆ Speed loop PI parameters vary with running frequencies of the inverter.

| Parameter      | Name                   | Factory Value | Setting Range | Content |
|----------------|------------------------|---------------|---------------|---------|
| 11-00<br>P.320 | Slip compensation gain | 85%           | 0~200%        | ---     |

### 5.11.2 Torque compensation filter

- ◆ Setting torque compensation filter coefficients, the set value, the greater the filter.

| Parameter      | Name                                    | Factory Value | Setting Range | Content |
|----------------|---|---------------|---------------|---------|
| 11-01<br>P.321 | Torque compensation filter coefficients | 20            | 0~32          | ---     |

### 5.11.3 Current filter

- ◆ Set the current filter coefficients, the set value, the greater the filter.

| Parameter      | Name   | Factory Value | Setting Range | Content |
|----------------|--|---------------|---------------|---------|
| 11-02<br>P.322 | First set of current filter cutoff frequency point of time | 4.00Hz        | 0~30.00Hz     | ---     |
| 11-03<br>P.323 | First set of current filtering time                        | 20.00ms       | 0~400.00ms    | ---     |
| 11-04<br>P.324 | Second group of current filter time at low frequency       | 1.00ms        | 0~400.00ms    | ---     |
| 11-05<br>P.325 | Second group of current filtering time                     | 36.00ms       | 0~400.00ms    | ---     |

## 5.12 Special adjustment parameter group13

| Group | Parameter Number | Name                                       | Setting Range | Factory Value | Page |
|-------|------------------|--|---------------|---------------|------|
| 13-00 | P.89             | Slip compensation coefficient              | 0 ~ 10        | 0             | 155  |
| 13-03 | P.286            | High frequency vibration inhibition factor | 0 ~ 15        | 9             | 155  |

### 5.12.1 Slip compensation V/F

- ◆ This parameter can be used to set compensation frequency and reduce the slip to close the setting speed when the motor runs in the rated current to raise the speed control accuracy.

| Parameter     | Name                          | Factory Value | Setting Range | Content   |
|---------------|-------------------------------|---------------|---------------|---|
| 13-00<br>P.89 | Slip compensation coefficient | 0             | 0 ~ 10        | 0: Slip compensation is forbidden.<br>10: The compensation value is 3% of the target frequency. |

Note: 1.This function is only valid under the V/F mode(00-21="0").

2. During slip compensation, the output frequency may be larger than the setting frequency.

### 5.12.2 Vibration inhibition

- ◆ Inhibit the great vibration of inverter output current and motor rotation speed and the motor vibration.

| Parameter      | Name                                       | Factory Value | Setting Range | Content  |
|----------------|--|---------------|---------------|--|
| 13-03<br>P.286 | High frequency vibration inhibition factor | 0             | 0 ~ 15        | If motor vibration is generated at higher frequency, adjust the set value of 13-03. Gradually increase the set value by the unit of 1. |

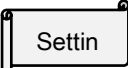
 Vibration inhibition factor

- ◆ For the actual application, use the vibration-generating frequency that is lower or higher than half of the motor rated frequency to determine whether the occurred vibration is a low-frequency vibration or a high-frequency vibration.i.e.

If the rated frequency on the name plate of the motor is 50Hz,

And the vibration-generating frequency is lower than 25Hz, and then this is a low-frequency vibration.

On the other hand, if the vibration-generating frequency is higher than 25Hz, then this is a high-frequency vibration.

Note: When the motor load is light, current flow may happen at certain specific operation frequency. This situation may cause the motor to vibrate slightly. The user can neglect it if this trivial vibration has no impact on the application.

### 5.13 User parameter Group 15

| Group | Parameter Number | Name                           | Setting Range   | Factory Value | Page |
|-------|------------------|--------------------------------|---|---------------|------|
| 15-00 | P.900            | User registration parameter 1  | P parameter model : 0 ~ 321<br>Parameter groups pattern : 00-00~13-03 | 99999         | 157  |
| 15-01 | P.901            | User registration parameter 2  |   | 99999         |      |
| 15-02 | P.902            | User registration parameter 3  |   | 99999         |      |
| 15-03 | P.903            | User registration parameter 4  |   | 99999         |      |
| 15-04 | P.904            | User registration parameter 5  |   | 99999         |      |
| 15-05 | P.905            | User registration parameter 6  |   | 99999         |      |
| 15-06 | P.906            | User registration parameter 7  |   | 99999         |      |
| 15-07 | P.907            | User registration parameter 8  |   | 99999         |      |
| 15-08 | P.908            | User registration parameter 9  |   | 99999         |      |
| 15-09 | P.909            | User registration parameter 10 |   | 99999         |      |
| 15-10 | P.910            | User registration parameter 11 |   | 99999         |      |
| 15-11 | P.911            | User registration parameter 12 |   | 99999         |      |
| 15-12 | P.912            | User registration parameter 13 |   | 99999         |      |
| 15-13 | P.913            | User registration parameter 14 |   | 99999         |      |
| 15-14 | P.914            | User registration parameter 15 |   | 99999         |      |
| 15-15 | P.915            | User registration parameter 16 |   | 99999         |      |
| 15-16 | P.916            | User registration parameter 17 |   | 99999         |      |
| 15-17 | P.917            | User registration parameter 18 |   | 99999         |      |
| 15-18 | P.918            | User registration parameter 19 |   | 99999         |      |
| 15-19 | P.919            | User registration parameter 20 |   | 99999         |      |

## 5.13.1 User registration parameters

- ◆ User parameter groups register parameters of number which users do not need to be restored the factory values.

| Parameter      | Name                           | Factory Value | Setting Range  | Content |
|----------------|--------------------------------|---------------|--|---------|
| 15-00<br>P.900 | User registration parameter 1  | 99999         | P parameter model : 0 ~ 321<br>Parameter groups pattern :<br>00-00~13-03 | ---     |
| 15-01<br>P.901 | User registration parameter 2  | 99999         |  | ---     |
| 15-02<br>P.902 | User registration parameter 3  | 99999         |  | ---     |
| 15-03<br>P.903 | User registration parameter 4  | 99999         |  | ---     |
| 15-04<br>P.904 | User registration parameter 5  | 99999         |  | ---     |
| 15-05<br>P.905 | User registration parameter 6  | 99999         |  | ---     |
| 15-06<br>P.906 | User registration parameter 7  | 99999         |  | ---     |
| 15-07<br>P.907 | User registration parameter 8  | 99999         |  | ---     |
| 15-08<br>P.908 | User registration parameter 9  | 99999         |  | ---     |
| 15-09<br>P.909 | User registration parameter 10 | 99999         |  | ---     |
| 15-10<br>P.910 | User registration parameter 11 | 99999         |  | ---     |
| 15-11<br>P.911 | User registration parameter 12 | 99999         |  | ---     |
| 15-12<br>P.912 | User registration parameter 13 | 99999         |  | ---     |
| 15-13<br>P.913 | User registration parameter 14 | 99999         |  | ---     |
| 15-14<br>P.914 | User registration parameter 15 | 99999         |  | ---     |
| 15-15<br>P.915 | User registration parameter 16 | 99999         |  | ---     |
| 15-16<br>P.916 | User registration parameter 17 | 99999         |  | ---     |
| 15-17<br>P.917 | User registration parameter 18 | 99999         |  | ---     |
| 15-18<br>P.918 | User registration parameter 19 | 99999         |  | ---     |
| 15-19<br>P.919 | User registration parameter 20 | 99999         |  | ---     |

 User registration parameters

- ◆ Parameters in the parameter group, when performing 00-02 = 5/6, will not be restored the factory values.
- ◆ This parameter values of parameters group are number of the user register, when performing 00-02 = 5/6, will not be restored the factory value.
- ◆ Restore the factory value, please refer to 5.1.2 management part of the value.

## 6. INSPECTION AND MAINTENANCE

### 6.1 Inspection item

#### 6.1.1 Daily inspection item

- ◆ The inverter is a unit mainly consisting of semiconductor devices. Daily inspection must be performed to prevent any fault from occurring due to the adverse effects of the operating environment, such as temperature, humidity, dust, dirt and vibration, changes in the parts with time, service life, and other factors.
  1. Check whether the surrounding conditions are normal (including temperature, humidity, dust density, etc.) at the place of the installation.
  2. Check whether the power supply voltage is normal (the voltage between R/L1, S/L2 and T/L3).
  3. Check whether the wiring is secured (whether the external wiring for the main-circuit board and the control-board terminal are secured).
  4. Check whether the cooling system is normal (whether there's any abnormal noise during the operation and whether the wiring is well secured).
  5. Check whether the indicator lamp is normal (whether the indicator lamp of the control board and of the operation panel and the LED monitor of the operation panel are normal).
  6. Check whether the operation is as expected.
  7. Check whether there is any abnormal vibration, noise or odor during the operation.
  8. Check whether there is any leakage from the filter capacitor.

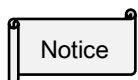

Be careful in inspection!

#### 6.1.2 Periodical inspection items

- ◆ Check the areas inaccessible during operation and requiring periodic inspection.
  1. Check the connectors and wiring (whether the connectors and wiring between the main-circuit board and control board are secured and without damage).
  2. Check whether the components on the main-circuit board and the control board are overheated.
  3. Check whether the electrolytic capacitors on the main-circuit board and control board have leakage.
  4. Check the IGBT module on the main-circuit board.
  5. Clean the dust and foreign substance on the circuit board.
  6. Check the insulation resistor.
  7. Check whether the cooling system is normal (whether the wiring of fan is secured; clean the air filter, etc.)
  8. Check the screws and belts.
  9. Check the external wires and the terminal banks for damage.

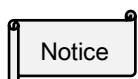

Be careful in inspection!

### 6.1.3 Cleaning

- ◆ Always run the inverter in a clean status.
- ◆ Use a soft brush to remove the dust and sundry on the fan blade, fan cover, and radiator, keeping the inverter in good heat dissipation.
- ◆ Gently wipe dirty areas of the cover with a soft cloth immersed in neutral detergent.

Note: 1. Do not use solvent, such as acetone, benzene, toluene and alcohol, as these will cause the inverter surface paint to peel off.

2. The operating panel is vulnerable to detergent and alcohol. Therefore, avoid using them for cleaning.

### 6.1.4 Replacement of parts

- The inverter consists of many electronic parts such as semiconductor devices.
- The following parts may deteriorate with age because of their structures or physical characteristics, leading to reduced performance or fault of the inverter. For preventive maintenance, the parts must be replaced periodically.
- Use the life check function as a guidance of parts replacement.

| Part name        | Estimated lifespan | Description   |
|------------------|--------------------|---|
| Cooling fan      | 2 years            | For the axle of a fan, the standard lifetime is about 10 – 35 thousand hours. Assuming that the fan operates 24 hours per day, the fan should be replaced every 2 years.                        |
| Filter capacitor | 5 years            | The filter capacitor is an electrolytic capacitor that deteriorates with time. The deterioration speed is contingent on the ambient conditions. Generally, it should be replaced every 5 years. |
| Relay            | ---                | If bad contact occurs, please replace it immediately.   |

Note: 1. Please send the inverters to the factory for complement replacement.

2. For the replacement of cooling fan, please refer to Section 3.10.

## 6.2 Measurement of main circuit voltages, currents and powers

### 6.2.1 Selection of instruments for measurement

- ◆ Since the voltages and currents on the inverter input sides and output sides include harmonics, measurement data depends on the instruments used and circuits measured. When instruments for commercial frequency are used for measurement, measure the circuits with the following instruments.

|                               | Voltage(V)       | Current(A)       | Power(kW)            |
|-------------------------------|------------------|------------------|----------------------|
| Input side(R/L1, S/L2, T/L3)  | Moving-iron type | Moving-iron type | Electrodynamics type |
| DC side                       | Moving-coil type | ---              | ---                  |
| Output side(U/T1, V/T2, W/T3) | Rectifier type   | Moving-iron type | Electrodynamics type |

Note: 1. Please pay attention to the instrument range and polarity;  
2. Look out for safety.

### 6.2.2 Measurement of voltages

#### ➤ Inverter input side

As the input side voltage has a sine wave and it is extremely small in distortion, accurate measurement can be made with an ordinary AC meter.

#### ➤ Inverter output side

Since the output side voltage has a PWM-controlled rectangular wave, always use a rectifier type voltmeter.

A needle type tester cannot be used to measure the output side voltage as it indicates a value much greater than the actual value.

A moving-iron type meter indicates an effective value which includes harmonics and therefore the value is larger than that of the fundamental wave.

The value monitored on the operation panel is the inverter-controlled voltage itself. Hence, that value is accurate and it is recommended to monitor values (analog output) using the operation panel.

### 6.2.3 Measurement of currents

- Use moving-iron type meters on both the input and output sides of the inverter. However, if the carrier frequency exceeds 5 kHz, do not use that meter since an over current losses produced in the internal metal parts of the meter will increase and the meter may burn out. In this case, use an approximate-effective value type.
- Since current on the inverter input side tends to be unbalanced, measurement of three phases is recommended. Correct value cannot be obtained by measuring only one or two phases. On the other hand, the unbalanced ratio of each phase of the output side current should be within 10%.
- When a clamp ammeter is used, always use an effective value detection type. A mean value detection type produces a large error and may indicate an extremely smaller value than the actual value. The value monitored on the operation panels accurate if the output frequency varies, and it is recommended to monitor values (provide analog output) using the operation panel.

### 6.2.4 Measurement of power

- Use digital power meters (for inverter) for the both of inverter input and output side. Alternatively, measure using electro-dynamics type single-phase watt meters for the both of inverter input and output side in two-wattmeter or three-wattmeter method. As the current is liable to be imbalanced especially in the input side, it is recommended to use the three-wattmeter method.

### 6.2.5 Measurement of insulation resistance

- Inverter insulation resistance
  1. Before measuring the inverter insulation resistance, first dismount the “Wiring of all the main-circuit terminals” and the “control board.” Then Execute the wiring as shown in the right picture.
  2. The measurement is only suitable for the main circuit. It is prohibited to Use a high-resistance meter for measuring terminals on the control board.
  3. The value of the insulation resistance shall be greater than 5MΩ.

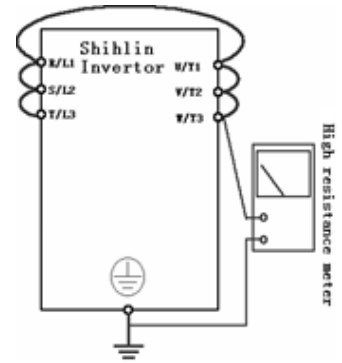

Note: Please use a 500 VDC megger.

- Motor insulation resistance
  1. Before the measurement, please dismount the motor, and execute The wiring as shown in the diagram on the right.
  2. The value of the insulation resistance shall be greater than 5MΩ.

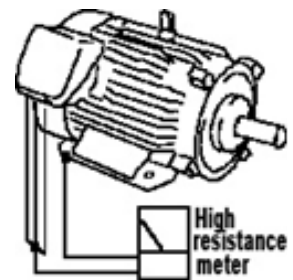

Note: Please use a suitable megger.

### 6.2.6 Hi-pot test

- ◆ Do not conduct a hi-pot test. Deterioration may occur on the internal semiconductor components of the inverter.

## 7. APPENDIX

## 7.1 Appendix 1 Parameter table

| Parameter Number | Group | Name                                   | Setting Range   | Factory Value     | Page       |
|------------------|-------|--|---|-------------------|------------|
| P.0              | 01-10 | Torque boost                           | 0.2 ~ 0.75K types: 0 ~ 30.0%                                  | 6.0%              | 47         |
|                  |       |  | 1.5K ~ 3.7K types: 0 ~ 30.0%                                  | 4.0%              |            |
|                  |       |  | 5.5K types: 0 ~ 30.0%   | 3.0%              |            |
| P.1              | 01-00 | Maximum frequency                      | 0.00 ~ 01-02(P.18)Hz  | 120HZ             | 62         |
| P.2              | 01-01 | Minimum frequency                      | 0 ~ 120.00Hz  | 0.00Hz            | 62         |
| P.3              | 01-03 | Base frequency                         | 50Hz system setting: 0 ~ 650.00Hz                             | 50.00Hz           | 63         |
|                  |       |  | 60Hz system setting: 0 ~ 650.00Hz                             | 60.00Hz           |            |
| P.4              | 04-00 | Speed1(high speed)                     | 0 ~ 650.00Hz  | 60.00Hz           | 97         |
| P.5              | 04-01 | Speed2(medium speed)                   | 0 ~ 650.00Hz  | 30.00Hz           | 97         |
| P.6              | 04-02 | Speed3(low speed)                      | 0 ~ 650.00Hz  | 10.00Hz           | 97         |
| P.7              | 01-06 | Acceleration time                      | 3.7K and types below: 0 ~ 360.00s/0 ~ 3600.0s                 | 5.00s             | 64         |
|                  |       |  | 5.5K types: 0 ~ 360.00s/0 ~ 3600.0s                           | 10.00s            |            |
| P.8              | 01-07 | Deceleration time                      | 3.7K and types below: 0 ~ 360.00s/0 ~ 3600.0s                 | 5.00s             | 64         |
|                  |       |  | 5.5K types: 0 ~ 360.00s/0 ~ 3600.0s                           | 10.00s            |            |
| P.9              | 06-00 | Electronic thermal relay capacity      | 0~500.00A   | According to type | 109        |
| P.10             | 10-00 | DC injection brake operation frequency | 0 ~ 120.00Hz  | 3.00Hz            | <u>142</u> |
| P.11             | 10-01 | DC injection brake operation time      | 0 ~ 60.0s   | 0.5s              | <u>142</u> |
| P.12             | 10-02 | DC injection brake operation voltage   | 0 ~ 30.0%   | 4.0%              | <u>142</u> |
| P.13             | 01-11 | Starting frequency                     | 0 ~ 60.00Hz   | 0.50Hz            | 66         |
| P.14             | 01-12 | Load pattern selection                 | 0: Applicable to constant torque loads (convey belt, etc.)    | 0                 | 67         |
|                  |       |  | 1: Applicable to variable torque loads (fans and pumps, etc.) |                   |            |
|                  |       |  | 2, 3: Applicable to ascending / descending loads.             |                   |            |
|                  |       |  | 4: Multipoint VF curve.                                       |                   |            |
|                  |       |  | 5 ~ 13: Special two-point VF curve.                           |                   |            |
| P.15             | 01-13 | JOG frequency                          | 0 ~ 650.00Hz  | 5.00Hz            | 69         |
| P.16             | 01-14 | JOG acceleration/ deceleration time    | 0 ~ 360.00s/0 ~ 3600.0s                                       | 0.50s             | 69         |

Appendix 1 Parameter table

| Parameter Number | Group | Name  | Setting Range   | Factory Value | Page |
|------------------|-------|---|---|---------------|------|
| P.17             | 02-20 | 3-5 signal selection                          | 0: Effective range of signal sampling is 4~20mA.  | 1             | 78   |
|                  |       |   | 1: Effective range of signal sampling is 0 ~ 10V.   |               |      |
|                  |       |   | 2: Effective range of signal sampling is 0 ~ 5V.  |               |      |
| P.18             | 01-02 | High-speed maximum frequency                  | 01-00(P.1) ~ 650.00Hz   | 120.00Hz      | 62   |
| P.19             | 01-04 | Base frequency voltage                        | 0 ~ 1000.0V   | 99999         | 63   |
|                  |       |   | 99999: Change according to the input voltage  |               |      |
| P.20             | 01-09 | Acceleration/deceleration reference frequency | 50Hz system setting: 1.00 ~ 650.00Hz  | 50.00Hz       | 64   |
|                  |       |   | 60Hz system setting: 1.00 ~ 650.00Hz  | 60.00Hz       |      |
| P.21             | 01-08 | Acceleration/deceleration time increments     | 0: Time increment is 0.01s  | 0             | 64   |
|                  |       |   | 1: Time increment is 0.1s   |               |      |
| P.22             | 06-01 | Stall prevention operation level              | 0 ~ 2500%   | 150.0%        | 109  |
| P.23             | 06-02 | Compensation factor at level reduction        | 0 ~ 200.0%  | 99999         | 109  |
|                  |       |   | 99999: Stall prevention operation level is the setting value of 06-01(P.22).  |               |      |
| P.24             | 04-03 | Speed 4                                       | 0 ~ 650.00Hz  | 99999         | 97   |
|                  |       |   | 99999: Function invalid   |               |      |
| P.25             | 04-04 | Speed 5                                       | Same as 04-03   | 99999         | 97   |
| P.26             | 04-05 | Speed 6                                       | Same as 04-03   | 99999         | 97   |
| P.27             | 04-06 | Speed 7                                       | Same as 04-03   | 99999         | 97   |
| P.28             | 01-15 | Output frequency filter time                  | 0 ~ 31  | 0ms           | 69   |
| P.29             | 01-05 | Acceleration/deceleration curve selection     | 0: Linear acceleration /deceleration curve  | 0             | 64   |
|                  |       |   | 1: S pattern acceleration /deceleration curve 1   |               |      |
|                  |       |   | 2: S pattern acceleration /deceleration curve 2   |               |      |
|                  |       |   | 3: S pattern acceleration /deceleration curve 3   |               |      |
| P.30             | 06-05 | Regenerative brake function selection         | 0: If regenerative brake duty is fixed at 3%, parameter06-06(P.70) will be invalid.   | 0             | 110  |
|                  |       |   | 1: The regenerative brake duty is the value of 06-06(P.70).   |               |      |
| P.31             | 00-12 | Soft-PWM carrier operation selection          | 0: None Soft-PWM operation  | 0             | 54   |
|                  |       |   | 1: When 00-11(P.72)< 5, Soft-PWM is valid (only apply to V/F control )  |               |      |
|                  |       |   | 2: When >9, Inverter module's temperature is exorbitant, carrier will automatically lower, after module's temperature dropping, carrier will automatically return to p. 72 set value. |               |      |
| P.32             | 07-02 | Serial communication Baud rate selection      | 0: Baud rate:4800bps  | 1             | 116  |
|                  |       |   | 1: Baud rate:9600bps  |               |      |
|                  |       |   | 2: Baud rate:19200bps   |               |      |
|                  |       |   | 3: Baud rate:38400bps   |               |      |
|                  |       |   | 4: Baud rate:57600bps   |               |      |
|                  |       |   | 5: Baud rate:115200bps  |               |      |

Appendix 1 Parameter table

| Parameter Number | Group | Name  | Setting Range  | Factory Value     | Page |
|------------------|-------|---|--|-------------------|------|
| P.33             | 07-00 | Communication protocol selection                | 0: Modbus protocol   | 1                 | 116  |
|                  |       |   | 1: Shihlin protocol  |                   |      |
| P.34             | 07-11 | Writing selection of communication EEPROM       | 0: Write parameters in communication mode, write into RAM and EEPROM                           | 0                 | 132  |
|                  |       |   | 1: Write parameters in communication mode, write into only RAM                                 |                   |      |
| P.35             | 00-19 | Communication mode instruction selection        | 0: In communication mode, operating instruction and setting frequency is set by communication. | 0                 | 57   |
|                  |       |   | 1: In communication mode, operating instruction and setting frequency is set by external.      |                   |      |
| P.36             | 07-01 | Inverter station number                         | 0 ~ 254  | 0                 | 116  |
| P.37             | 00-08 | Speed display                                   | 0: Display output frequency(the mechanical speed is not displayed)                             | 0                 | 53   |
|                  |       |   | 0.1~5000.0   |                   |      |
|                  |       |   | 1~9999   |                   |      |
| P.39             | 02-21 | The maximum operation frequency of terminal 3-5 | 50Hz system: 1.00 ~ 650.00Hz   | 50.00Hz           | 78   |
|                  |       |   | 60Hz system: 1.00 ~ 650.00Hz   | 60.00Hz           |      |
| P.41             | 03-20 | Up-to-frequency sensitivity                     | 0 ~ 100.0%   | 10.0%             | 93   |
| P.42             | 03-21 | Output frequency detection for forward rotation | 0 ~ 650.00Hz   | 6.00Hz            | 93   |
| P.43             | 03-22 | Output frequency detection for reverse rotation | 0 ~ 650.00Hz   | 99999             | 93   |
|                  |       |   | 99999: Same as the setting of 03-21(P.42)  |                   |      |
| P.44             | 01-22 | The second acceleration time                    | 0 ~ 360.00s/0 ~ 3600.0s  | 99999             | 71   |
|                  |       |   | 99999: Not selected  |                   |      |
| P.45             | 01-23 | The second deceleration time                    | 0 ~ 360.00s/0 ~ 3600.0s  | 99999             | 71   |
|                  |       |   | 99999: Not selected  |                   |      |
| P.46             | 01-24 | The second torque boost                         | 0 ~ 30.0%  | 99999             | 71   |
|                  |       |   | 99999: Not selected  |                   |      |
| P.47             | 01-25 | The second base frequency                       | 0 ~ 650.00Hz   | 99999             | 71   |
|                  |       |   | 99999: Not selected  |                   |      |
| P.48             | 07-03 | Data length                                     | 0: 8bit  | 0                 | 116  |
|                  |       |   | 1: 7bit  |                   |      |
| P.49             | 07-04 | Stop bit length                                 | 0: 1bit  | 0                 | 116  |
|                  |       |   | 1: 2bit  |                   |      |
| P.50             | 07-05 | Parity check selection                          | 0: No parity verification  | 0                 | 116  |
|                  |       |   | 1: Odd   |                   |      |
|                  |       |   | 2: Even  |                   |      |
| P.51             | 07-06 | CR/LFselection                                  | 1: CR only   | 1                 | 116  |
|                  |       |   | 2: Both CR and LF  |                   |      |
| P.52             | 07-08 | Number of communication retries                 | 0 ~ 10   | 1                 | 116  |
| P.53             | 07-09 | Communication check time interval               | 0~999.8s: Use the set value for the communication overtime test.                               | 99999             | 123  |
|                  |       |   | 99999: No communication overtime test.   |                   |      |
| P.56             | 02-52 | Output current display the datum                | 0~500.00A  | According to type | 83   |
| P.57             | 10-09 | Restart coasting time                           | 0 ~ 30.0s  | 99999             | 144  |
|                  |       |   | 99999: No restart function.  |                   |      |

| Parameter Number | Group | Name   | Setting Range  | Factory Value | Page       |
|------------------|-------|--|--|---------------|------------|
| P.58             | 10-10 | Restart cushion time                               | 0 ~ 60.0s  | 5.0s          | 154        |
| P.59             | 00-10 | Operating keyboard knob Settings locking selection | XXX0: The frequency set by frequency inverter itself shuttle knob is effective   | 0             | 54         |
|                  |       |  | XXX1: The frequency set by the knob of the manipulator is effective.   |               |            |
|                  |       |  | X0XX: After changing the frequency, automatic storage after 30 s   |               |            |
|                  |       |  | X1XX : After changing the frequency, automatic storage after 10 s  |               |            |
|                  |       |  | X2XX : After changing the frequency, don't store automatically   |               |            |
|                  |       |  | 0XXX: After to shuttle set frequency, the frequency of changes take effect immediately   |               |            |
|                  |       |  | 1XXX: After to shuttle set frequency and the set key run, the frequency of change take effect.                                       |               |            |
| P.60             | 02-10 | 3-5 filter time                                    | 0 ~ 2000ms   | 31            | <u>78</u>  |
| P.61             | 10-11 | Remote setting function selection                  | 0: No remote setting function.   | 0             | <u>145</u> |
|                  |       |  | 1: Remote setting function, frequency setup storage is available.  |               |            |
|                  |       |  | 2: Remote setting function, frequency setup storage is not available.  |               |            |
|                  |       |  | 3: Remote setting function, frequency setup storage is not available; the remote setting frequency is cleared by STF/STR "turn off". |               |            |
| P.62             | 03-23 | Zero current detection level                       | 0 ~ 200.0%   | 5.0%          | 94         |
|                  |       |  | 99999: Function invalid  |               |            |
| P.63             | 03-24 | Zero current detection time                        | 0.05 ~ 100.0s  | 0.50s         | 94         |
|                  |       |  | 99999 : Function is invalid  |               |            |
| P.65             | 10-12 | Retry selection                                    | 0: Retry is invalid.   | 0             | 147        |
|                  |       |  | 1: Over-voltage occurs, the inverter will perform the retry function.  |               |            |
|                  |       |  | 2: Over-current occurs, the inverter will perform the retry function.  |               |            |
|                  |       |  | 3: Over-voltage or over-current occurs, the inverter will perform the retry function.  |               |            |
|                  |       |  | 4: All the alarms have the retry function.   |               |            |

Appendix 1 Parameter table

| Parameter Number | Group | Name  | Setting Range  | Factory Value | Page       |
|------------------|-------|---|--|---------------|------------|
| P.66             | 06-03 | Stall prevention operation reduction starting frequency | 50Hz system: 0 ~ 650.00Hz  | 50.00Hz       | 109        |
|                  |       |   | 60Hz system: 0 ~ 650.00Hz  | 60.00Hz       |            |
| P.67             | 10-13 | Number of retries at alarm occurrence                   | 0: Retry is invalid.   | 0             | <u>147</u> |
|                  |       |   | 1 ~ 10: The setting value of 10-13(P.67) is exceeded; the inverter will not perform the retry function.    |               |            |
| P.68             | 10-14 | Retry waiting time                                      | 0 ~ 360.0s   | 6.0s          | 147        |
| P.69             | 10-15 | Retry accumulation time at alarm                        | Read   | 0             | 147        |
| P.70             | 06-06 | Special regenerative brake duty                         | 0 ~ 100.0%   | 0.0%          | <u>110</u> |
| P.71             | 00-13 | Idling braking / DC braking                             | 0: Idling braking  | 1             | <u>55</u>  |
|                  |       |   | 1: DC braking  |               |            |
| P.72             | 00-11 | Carrier frequency                                       | 1~15 kHz   | 5 kHz         | <u>54</u>  |
| P.75             | 00-14 | Stop function selection                                 | 0: Press STOP button and stop the operation only in the PU and H2 mode                                     | 1             | <u>55</u>  |
|                  |       |   | 1: Press STOP button and stop the operation in all mode.   |               |            |
| P.77             | 00-03 | Selection of parameters write protection                | 0: Parameters can be written only when the motor stops.  | 0             | <u>50</u>  |
|                  |       |   | 1: Parameters cannot be written.   |               |            |
|                  |       |   | 2: Parameters can also be written when the motor is running.   |               |            |
|                  |       |   | 3: Parameters cannot be written when in password protection.   |               |            |
| P.78             | 00-15 | Forward/reverse rotation prevention selection           | 0: Forward rotation and reverse rotation are both permitted.   | 0             | <u>56</u>  |
|                  |       |   | 1: Reverse rotation is prohibited (Press the reverse reference to decelerate and stop the motor).          |               |            |
|                  |       |   | 2: Forward rotation is prohibited (Press the forward rotation reference to decelerate and stop the motor). |               |            |

| Parameter Number     | Group | Name                     | Setting Range   | Factory Value | Page |
|----------------------|-------|--------------------------|---|---------------|------|
| P.79                 | 00-16 | Operation mode selection | 0: "PU mode", "external mode" and "Jog mode" are interchangeable. | 0             | 57   |
|                      |       |                          | 1: "PU mode" and "JOG mode" are interchangeable.                  |               |      |
|                      |       |                          | 2: "External mode" only   |               |      |
|                      |       |                          | 3: "Communication mode" only                                      |               |      |
|                      |       |                          | 4: "Combined mode 1"  |               |      |
|                      |       |                          | 5: "Combined mode 2"  |               |      |
|                      |       |                          | 6: "Combined mode 3"  |               |      |
|                      |       |                          | 7: "Combined mode 4"  |               |      |
| 8: "Combined mode 5" |       |                          |   |               |      |
| P.80                 | 03-03 | M0 function selection    | Same as 03-00   | 2             | 88   |
| P.81                 | 03-04 | M1 function selection    | Same as 03-00   | 3             | 88   |
| P.83                 | 03-00 | STF function selection   | 0: STF(the inverter runs forward)                                 | 0             | 87   |
|                      |       |                          | 1: STR(the inverter runs reverse)                                 |               |      |
|                      |       |                          | 2: RL(Multi-speed low speed)                                      |               |      |
|                      |       |                          | 3: RM(Multi-speed medium speed)                                   |               |      |
|                      |       |                          | 4: RH(multi-speed high speed)                                     |               |      |
|                      |       |                          | 5: Reserved   |               |      |
|                      |       |                          | 6: The external thermal relay operation                           |               |      |
|                      |       |                          | 7: MRS(the instantaneous stopping of the inverter output)         |               |      |
|                      |       |                          | 8: RT(the inverter second function)                               |               |      |
|                      |       |                          | 9: EXT(external JOG)  |               |      |
|                      |       |                          | 10: STF+EXJ   |               |      |
|                      |       |                          | 11: STR+EXJ   |               |      |
|                      |       |                          | 12: STF+RT  |               |      |
|                      |       |                          | 13: STR+RT  |               |      |
|                      |       |                          | 14: STF+RL  |               |      |
|                      |       |                          | 15: STR+RL  |               |      |
|                      |       |                          | 16: STF+RM  |               |      |
|                      |       |                          | 17: STR+RM  |               |      |
|                      |       |                          | 18: STF+RH  |               |      |
|                      |       |                          | 19: STR+RH  |               |      |
|                      |       |                          | 19: STR+RH  |               |      |
|                      |       |                          | 20: STF+RL+RM   |               |      |
|                      |       |                          | 21: STR+RL+RM   |               |      |
|                      |       |                          | 22: STF+RT+RL   |               |      |
|                      |       |                          | 23: STR+RT+RL   |               |      |
|                      |       |                          | 24: STF+RT+RM   |               |      |
|                      |       |                          | 25: STR+RT+RM   |               |      |
| 26: STF+RT+RL+RM     |       |                          |   |               |      |
| 27: STR+RT+RL+RM     |       |                          |   |               |      |

Appendix 1 Parameter table

| Parameter Number   | Group | Name                   | Setting Range  | Factory Value | Page      |
|--|-------|------------------------|--|---------------|-----------|
| P.83   | 03-00 | STF function selection | 28: RUN(the inverter runs forward)   | 0             | 87        |
|  |       |                        | 29: STF/STR(it is used with RUN, when STF/STR is "on", the inverter runs reverse ; when STF/STR is "off", the inverter runs forward)                                   |               |           |
|  |       |                        | 30: RES(external reset function)   |               |           |
|  |       |                        | 31: STOP(it can be used as a three-wire mode with the RUN signal or the STF-STR terminal)  |               |           |
|  |       |                        | 32: REX(multi-speed set (16 levels))   |               |           |
|  |       |                        | 33: PO(in "external mode", programmed operation mode is chosen)  |               |           |
|  |       |                        | 34: RES_E (external reset become valid only when the alarm goes off.)  |               |           |
|  |       |                        | 35: MPO (in "external mode" the manually operation cycle mode is chosen.)  |               |           |
|  |       |                        | 36: TRI(triangle wave function is chosen)  |               |           |
|  |       |                        | 37: Reserved   |               |           |
|  |       |                        | 38: Reserved   |               |           |
|  |       |                        | 39: STF/STR +STOP (The motor has a reverse rotation when the RUN signal is on. When the RUN signal is off, stop the motor and then run the motor for forward rotation. |               |           |
|  |       |                        | 40: P_MRS (the inverter output instantaneously stops, The MRS is pulse signal input)   |               |           |
|  |       |                        | 42: Reserved   |               |           |
|  |       |                        | 43: RUN_EN (the digital input terminal running enable)   |               |           |
| 44: PID_OFF (the digital input terminal stopping PID enable) |       |                        |  |               |           |
| 45: The second mode  |       |                        |  |               |           |
| P.84   | 03-01 | STR function selection | Same as 03-00  | 1             | 88        |
| P.85   | 03-11 | A-C function selection | 0: RUN(inverter running)   | 5             | <u>90</u> |
|  |       |                        | 1: SU(reaching the output frequency)   |               |           |
|  |       |                        | 2: FU(output frequency detection)  |               |           |
|  |       |                        | 3: OL(overload detection)  |               |           |
|  |       |                        | 4: OMD(zero current detection)   |               |           |
|  |       |                        | 5: ALARM(alarm detection)  |               |           |
|  |       |                        | 6: PO1(programmed operation section detection)   |               |           |
|  |       |                        | 7: PO2(programmed operation periodical detection)  |               |           |
| 8: PO3(programmed operation pause detection)                 |       |                        |  |               |           |

Appendix 1 Parameter table

| Parameter Number | Group | Name   | Setting Range  | Factory Value | Page       |
|------------------|-------|--|--|---------------|------------|
| P.85             | 03-11 | A-C function selection   | 9: Reserved  | 5             | <u>90</u>  |
|                  |       |  | 10: Reserved   |               |            |
|                  |       |  | 11: OMD1(zero current detection)                         |               |            |
|                  |       |  | 12: OL2 (Over torque alarm output)                       |               |            |
|                  |       |  | 13 ~ 16: Reserved  |               |            |
|                  |       |  | 17: RY(the accomplishmentofinverter running preparation) |               |            |
|                  |       |  | 18: Maintenance alarm detection                          |               |            |
| P.87             | 03-14 | Multi-functionterminaldigital inputnegative/positive logic     | 0 ~ 15   | 0             | 91         |
| P.88             | 03-15 | Multi-function terminal digital output negative/positive logic | 0:AC terminaloutput positive logic                       | 0             | 91         |
|                  |       |  | 2:AC terminaloutput negative logic                       |               |            |
| P.89             | 13-00 | Slip compensation coefficient                                  | 0 ~ 10   | 0             | <u>155</u> |
| P.90             | 00-00 | The inverter model   | Read   | ---           | 50         |
| P.91             | 01-16 | Frequency jump 1A  | 0 ~ 650.00Hz   | 99999         | <u>70</u>  |
|                  |       |  | 99999: invalid   |               |            |
| P.92             | 01-17 | Frequency jump 1B  | 0 ~ 650.00Hz   | 99999         | <u>70</u>  |
|                  |       |  | 99999: invalid   |               |            |
| P.93             | 01-18 | Frequency jump 2A  | 0 ~ 650.00Hz   | 99999         | <u>70</u>  |
|                  |       |  | 99999: invalid   |               |            |
| P.94             | 01-19 | Frequency jump 2B  | 0 ~ 650.00Hz   | 99999         | <u>70</u>  |
|                  |       |  | 99999: invalid   |               |            |
| P.95             | 01-20 | Frequency jump 3A  | 0 ~ 650.00Hz   | 99999         | <u>73</u>  |
|                  |       |  | 99999: invalid   |               |            |
| P.96             | 01-21 | Frequency jump 3B  | 0 ~ 650.00Hz   | 99999         | <u>70</u>  |
|                  |       |  | 99999: invalid   |               |            |
| P.97             | 00-17 | The second target frequency selection                          | 0: Frequency set by operation panel                      | 0             | <u>57</u>  |
|                  |       |  | 1: Frequency set by Communication RS485                  |               |            |
|                  |       |  | 2: Frequency set by the analog                           |               |            |
| P.98             | 01-26 | Middle frequency 1   | 0 ~ 650.00Hz   | 3.00Hz        | <u>72</u>  |
| P.99             | 01-27 | Output voltage 1 of middle frequency                           | 0 ~ 100.0%   | 10.0%         | <u>72</u>  |

Appendix 1 Parameter table

| Parameter Number | Group | Name   | Setting Range  | Factory Value | Page |
|------------------|-------|--|--|---------------|------|
| P.100            | 04-15 | Minute/second selection                          | 0: The minimum increment of run time is 1 minute.  | 1             | 99   |
|                  |       |  | 1: The minimum increment of run time is 1 second.  |               |      |
| P.101            | 04-27 | Programmed operation mode speed 1 operating time | 0 ~ 6000.0s  | 0.0s          | 99   |
| P.102            | 04-28 | Programmed operation mode speed 2 operating time | 0 ~ 6000.0s  | 0.0s          | 99   |
| P.103            | 04-29 | Programmed operation mode speed3 operating time  | 0 ~ 6000.0s  | 0.0s          | 99   |
| P.104            | 04-30 | Programmed operation mode speed 4 operating time | 0 ~ 6000.0s  | 0.0s          | 99   |
| P.105            | 04-31 | Programmed operation mode speed 5 operating time | 0 ~ 6000.0s  | 0.0s          | 100  |
| P.106            | 04-32 | Programmed operation mode speed 6 operating time | 0 ~ 6000.0s  | 0.0s          | 100  |
| P.107            | 04-33 | Programmed operation mode speed 7 operating time | 0 ~ 6000.0s  | 0.0s          | 100  |
| P.108            | 04-34 | Programmed operation mode speed 8 operating time | 0 ~ 6000.0s  | 0.0s          | 100  |
| P.110            | 00-06 | Operation panel monitoring selection             | 0: When the inverter starts, the operation panel enters the monitoring mode automatically, and the screen displays the output frequency.   | 2             | 52   |
|                  |       |  | 1: When the inverter starts, the screen of the operation panel displays the target frequency.  |               |      |
|                  |       |  | 2: When the inverter starts, the operation panel enters the monitoring mode automatically, and the screen displays the current pressure and feedback pressure of the constant pressure system. |               |      |
|                  |       |  | 3 : When the inverter starts, operatorbeginsmonitor mode automatically, display the current target pressure and feedback constant pressure system (note)                                       |               |      |
|                  |       |  | 4 : When the inverter starts,operator is no longer automatically monitor mode, display the inverter model before starting.   |               |      |

| Parameter Number | Group | Name   | Setting Range  | Factory Value | Page       |
|------------------|-------|--|--|---------------|------------|
| P.111            | 04-35 | Programmed operation mode speed 1 Acc/Dec time   | 0 ~ 600.00s/0 ~ 6000.0s  | 0.00s         | <u>100</u> |
| P.112            | 04-36 | Programmed operation mode speed 2 Acc/Dec time   | 0 ~ 600.00s/0 ~ 6000.0s  | 0.00s         | <u>100</u> |
| P.113            | 04-37 | Programmed operation mode speed 3 Acc/Dec time   | 0 ~ 600.00s/0 ~ 6000.0s  | 0.00s         | <u>100</u> |
| P.114            | 04-38 | Programmed operation mode speed 4 Acc/Dec time   | 0 ~ 600.00s/0 ~ 6000.0s  | 0.00s         | <u>100</u> |
| P.115            | 04-39 | Programmed operation mode speed 5 Acc/Dec time   | 0 ~ 600.00s/0 ~ 6000.0s  | 0.00s         | <u>100</u> |
| P.116            | 04-40 | Programmed operation mode speed 6 Acc/Dec time   | 0 ~ 600.00s/0 ~ 6000.0s  | 0.00s         | <u>100</u> |
| P.117            | 04-41 | Programmed operation mode speed 7 Acc/Dec time   | 0 ~ 600.00s/0 ~ 6000.0s  | 0.00s         | <u>100</u> |
| P.118            | 04-42 | Programmed operation mode speed 8 Acc/Dec time   | 0 ~ 600.00s/0 ~ 6000.0s  | 0.00s         | 100        |
| P.119            | 10-16 | The dead time of positive and reverse rotation   | 0 ~ 3000.0s  | 0.0s          | <u>148</u> |
| P.120            | 03-16 | Output signal delay time                         | 0 ~ 3600.0s  | 0.0s          | <u>92</u>  |
| P.121            | 04-16 | Run direction in each section                    | 0 ~ 255  | 0             | 99         |
| P.122            | 04-17 | Cycle selection                                  | 0: Cycle function invalid  | 0             | 99         |
|                  |       |  | 1 ~ 8: Run circularly from the setting section.  |               |            |
| P.123            | 04-18 | Acceleration/deceleration time setting selection | 0: The acceleration time is set by 01-06(P.7), the deceleration time is set by 01-07(P.8).   | 0             | 99         |
|                  |       |  | 1: The acceleration and deceleration time is both determined by 04-35(P.111) ~ 04-42(P.118). |               |            |
| P.131            | 04-19 | Programmed operation mode speed 1                | 0 ~ 650.00Hz   | 0.00Hz        | 99         |
| P.132            | 04-20 | Programmed operation mode speed 2                | 0 ~ 650.00Hz   | 0.00Hz        | 99         |
| P.133            | 04-21 | Programmed operation mode speed3                 | 0 ~ 650.00Hz   | 0.00Hz        | 99         |
| P.134            | 04-22 | Programmed operation mode speed 4                | 0 ~ 650.00Hz   | 0.00Hz        | 99         |

Appendix 1 Parameter table

| Parameter Number | Group | Name  | Setting Range                           | Factory Value | Page       |
|------------------|-------|---|---|---------------|------------|
| P.135            | 04-23 | Programmed operation mode speed 5                 | 0 ~ 650.00Hz                            | 0.00Hz        | 99         |
| P.136            | 04-24 | Programmed operation mode speed 6                 | 0 ~ 650.00Hz                            | 0.00Hz        | 99         |
| P.137            | 04-25 | Programmed operation mode speed 7                 | 0 ~ 650.00Hz                            | 0.00Hz        | 99         |
| P.138            | 04-26 | Programmed operation mode speed 8                 | 0 ~ 650.00Hz                            | 0.00Hz        | 99         |
| P.141            | 02-61 | Voltage signal offset direction and diversion set | 0~11                                    | 0             | <u>78</u>  |
| P.142            | 04-07 | Speed8  | 0 ~ 650.00Hz                            | 99999         | 97         |
| P.143            | 04-08 | Speed9  | Same as 04-03                           | 99999         | 97         |
| P.144            | 04-09 | Speed10   | Same as 04-03                           | 99999         | 97         |
| P.145            | 04-10 | Speed11   | Same as 04-03                           | 99999         | 97         |
| P.146            | 04-11 | Speed12   | Same as 04-03                           | 99999         | 97         |
| P.147            | 04-12 | Speed13   | Same as 04-03                           | 99999         | 97         |
| P.148            | 04-13 | Speed14   | Same as 04-03                           | 99999         | 97         |
| P.149            | 04-14 | Speed15   | Same as 04-03                           | 99999         | 97         |
| P.150            | 10-08 | Restart mode selection                            | X0: No frequency search.                | 0             | <u>144</u> |
|                  |       |   | X1: Reserved                            |               |            |
|                  |       |   | X2: Decrease voltage mode               |               |            |
|                  |       |   | 0X: Power on once.                      |               |            |
|                  |       |   | 1X: Start each time.                    |               |            |
|                  |       |   | 2X: Only instantaneous stop and restart |               |            |
| P.151            | 10-03 | Zero-speed control function selection             | 0: There is no output at zero-speed.    | 0             | <u>143</u> |
|                  |       |   | 1: DC voltage breaking                  |               |            |
| P.152            | 10-04 | Voltage at zero-speed control                     | 0 ~ 30.0%                               | 5.0%          | <u>143</u> |
| P.153            | 07-10 | Communication error handling                      | 0: Warn and call to stop                | 0             | <u>116</u> |
|                  |       |   | 1: No warning and keep running          |               |            |
| P.154            | 07-07 | Modbus communication format                       | 0: 1、7、N、2 (Modbus, ASCII)              | 4             | <u>116</u> |
|                  |       |   | 1: 1、7、E、1 (Modbus, ASCII)              |               |            |
|                  |       |   | 2: 1、7、O、1 (Modbus, ASCII)              |               |            |
|                  |       |   | 3: 1、8、N、2 (Modbus, RTU)                |               |            |
|                  |       |   | 4: 1、8、E、1 (Modbus, RTU)                |               |            |
|                  |       |   | 5: 1、8、O、1 (Modbus, RTU)                |               |            |

| Parameter Number                     | Group | Name                                | Setting Range  | Factory Value | Page       |
|--------------------------------------|-------|-------------------------------------|--|---------------|------------|
| P.155                                | 06-08 | Over torque detection level         | 0 ~ 200.0%   | 0.0%          | <u>111</u> |
| P.156                                | 06-09 | Over torque detection time          | 0 ~ 60.0s  | 1.0s          | <u>111</u> |
| P.157                                | 03-17 | Digital input terminal filter time  | 0 ~ 2000   | 4             | <u>92</u>  |
| P.158                                | 03-18 | Digital input terminal power enable | 0: Digital input terminal power disable  | 0             | <u>93</u>  |
|                                      |       |                                     | 1: Digital input terminal power enable   |               |            |
| P.159                                | 10-17 | Energy-saving control function      | 0: Normal running mode.  | 0             | <u>148</u> |
|                                      |       |                                     | 1: Energy-saving running mode.   |               |            |
| P.161                                | 00-07 | Multi-function display              | 0: Output voltage (V)  | 0             | 52         |
|                                      |       |                                     | 1: DC bus voltage (V)  |               |            |
|                                      |       |                                     | 2: Temperature rising accumulation rate of inverter (%)  |               |            |
|                                      |       |                                     | 3: Target pressure of the constant pressure system (%)   |               |            |
|                                      |       |                                     | 4: Feedback pressure of the constant pressure system (%)   |               |            |
|                                      |       |                                     | 5: Operation frequency (Hz)  |               |            |
|                                      |       |                                     | 6: Electronic thermal accumulation rate (%)  |               |            |
|                                      |       |                                     | 7: Signal value (V) of 3-5 simulating input terminals.   |               |            |
|                                      |       |                                     | 8: Signal value (mA) of 3-5 simulating input terminals (mA/V).   |               |            |
|                                      |       |                                     | 9: Output power (kW).  |               |            |
|                                      |       |                                     | 10: PG card's feedback rotation speed. (Hz)  |               |            |
|                                      |       |                                     | 11: Positive and reverse rotation signal. Then 1 represents positive rotation, 2 represents reverse rotation, and 0 represents stopping state. |               |            |
|                                      |       |                                     | 12: NTC temperature (°C)   |               |            |
|                                      |       |                                     | 13: Electronic thermal accumulation rate of motor (%)  |               |            |
|                                      |       |                                     | 14~18: Reserved.   |               |            |
| 19: Digital terminal input state     |       |                                     |  |               |            |
| 20: Digital terminal output state    |       |                                     |  |               |            |
| 21: Actual working carrier frequency |       |                                     |  |               |            |
| P.162                                | 01-28 | Middle frequency 2                  | 0 ~ 650.00Hz   | 99999         | 72         |
|                                      |       |                                     | 99999: Not selected  |               |            |

Appendix 1 Parameter table

| Parameter Number | Group | Name  | Setting Range  | Factory Value | Page       |
|------------------|-------|---|--|---------------|------------|
| P.163            | 01-29 | Output voltage 2 of middle frequency          | 0 ~ 100.0%   | 0.0%          | 72         |
| P.164            | 01-30 | Middle frequency 3                            | 0 ~ 650.00Hz   | 99999         | 72         |
|                  |       |   | 99999: Not selected  |               |            |
| P.165            | 01-31 | Output voltage 3 of middle frequency          | 0 ~ 100.0%   | 0.0%          | 72         |
| P.166            | 01-32 | Middle frequency 4                            | 0 ~ 650.00Hz   | 99999         | 72         |
|                  |       |   | 99999: Not selected  |               |            |
| P.167            | 01-33 | Output voltage 4 of middle frequency          | 0 ~ 100.0%   | 0.0%          | 72         |
| P.168            | 01-34 | Middle frequency 5                            | 0 ~ 650.00Hz   | 99999         | 72         |
|                  |       |   | 99999: Not selected  |               |            |
| P.169            | 01-35 | Output voltage 5 of middle frequency          | 0 ~ 100.0%   | 0.0%          | 72         |
| P.170            | 08-00 | PID function selection                        | 0: PID function non-selected   | 0             | <u>134</u> |
|                  |       |   | 2: Parameter 08-03(P.225) sets target value, take the input of terminal 3-5 as target source   |               |            |
| P.171            | 08-01 | PID feedback control method                   | 0: Negative feedback control.  | 0             | <u>134</u> |
|                  |       |   | 1: Positive feedback control.  |               |            |
| P.172            | 08-04 | Proportion gain                               | 1~100  | 20            | <u>134</u> |
| P.173            | 08-05 | Integral time                                 | 0 ~ 100.00s  | 1.00s         | <u>134</u> |
| P.174            | 08-06 | Differential time                             | 0 ~ 10000ms  | 0ms           | <u>134</u> |
| P.175            | 08-07 | Abnormal deviation                            | 0 ~ 100.0%   | 0.0%          | <u>134</u> |
| P.176            | 08-08 | Exception duration time                       | 0 ~ 600.0s   | 30.0s         | <u>134</u> |
| P.177            | 08-09 | Exception handling mode                       | 0: Free stop   | 0             | <u>134</u> |
|                  |       |   | 1: Decelerate and stop   |               |            |
|                  |       |   | 2: Continue to run when the alarm goes off   |               |            |
| P.178            | 08-10 | Sleep detects deviation                       | 0 ~ 100.0%   | 0.0%          | <u>134</u> |
| P.179            | 08-11 | Sleep detects duration time                   | 0 ~ 255.0s   | 1.0s          | <u>134</u> |
| P.180            | 08-12 | Revival level                                 | 0 ~ 100.0%   | 90.0%         | <u>134</u> |
| P.181            | 08-13 | Outage level                                  | 0 ~ 120.00Hz   | 40.00Hz       | <u>134</u> |
| P.182            | 08-14 | Integral upper limit                          | 50Hz : 0 ~ 120.00Hz  | 50.00Hz       | <u>134</u> |
|                  |       |   | 60Hz : 0 ~ 120.00Hz  | 60.00Hz       |            |
| P.183            | 08-15 | Deceleration step length with stable pressure | 0 ~ 10.00Hz  | 0.50Hz        | <u>134</u> |
| P.184            | 02-24 | 3-5 disconnection selection                   | 0: No disconnection selection is available.  | 0             | 78         |
|                  |       |   | 1: Decelerate to 0Hz, the digital output terminal will set off the alarm   |               |            |
|                  |       |   | 2: The inverter will stop immediately, and the panel will display the "AER" alarm.   |               |            |
|                  |       |   | 3: The inverter will run continuously according to the frequency reference before the disconnection. The digital output terminal will set off the alarm. |               |            |

| Parameter Number | Group | Name   | Setting Range  | Factory Value | Page       |
|------------------|-------|--|--|---------------|------------|
| P.185            | 02-06 | Proportion linkage gain  | 0 ~ 100%   | 0%            | 76         |
| P.188            | 00-01 | Firmware version   | Read   | ---           | 47         |
| P.189            | 00-24 | 50Hz/60Hz switch selection   | 0: The frequency parameter default value is 60Hz system.     | 0             | 61         |
|                  |       |  | 1: The frequency parameter default value is 50Hz system.     | 1             |            |
| P.196            | 02-27 | The percentage corresponding to the minimum input current/voltage of 3-5 | 0 ~ 100.0%   | 0.0%          | 83         |
| P.197            | 02-28 | The percentage corresponding to the maximum input current/voltage of 3-5 | 0 ~ 100.0%   | 100.0%        | 83         |
| P.198            | 02-25 | The minimum input current/voltage of terminal 3-5                        | 0 ~ 20.00mA/V  | 0.00V         | 83         |
| P.199            | 02-26 | The maximum input current/voltage of terminal 3-5                        | 0 ~ 20.00 mA/V   | 10.00 V       | 83         |
| P.223            | 08-18 | Analog feedback bias pressure  | 0 ~ 100.0%   | 0.0%          | <u>135</u> |
| P.224            | 08-19 | Analog feedback gain pressure  | 0 ~ 100.0%   | 100.0%        | <u>135</u> |
| P.225            | 08-03 | PID target value panel reference   | 0 ~ 100.0%   | 20.0%         | <u>134</u> |
| P.226            | 10-55 | Reciprocating mechanical function  | 0 : Reciprocating mechanical function is invalid             | 0             | <u>152</u> |
|                  |       |  | 1 : Reciprocating mechanical function effectively            |               |            |
| P.227            | 10-56 | Forward limit time   | 0~3600.0s  | 0.0s          | <u>152</u> |
| P.228            | 10-57 | Reversal limit time  | 0~3600.0s  | 0.0s          | <u>152</u> |
| P.229            | 10-18 | Dwell function selection   | 0: None.   | 0             | <u>149</u> |
|                  |       |  | 1: Backlash compensation function.                           |               |            |
|                  |       |  | 2: Acceleration and deceleration interrupt waiting function. |               |            |
| P.230            | 10-19 | Dwell frequency at acceleration  | 0 ~ 650.00Hz   | 1.00Hz        | <u>149</u> |
| P.231            | 10-20 | Dwell time at acceleration   | 0 ~ 360.0s   | 0.5s          | <u>149</u> |
| P.232            | 10-21 | Dwell frequency at deceleration  | 0 ~ 650.00Hz   | 1.0Hz         | <u>149</u> |

Appendix 1 Parameter table

| Parameter Number | Group | Name                                     | Setting Range   | Factory Value | Page       |
|------------------|-------|--|---|---------------|------------|
| P.233            | 10-22 | Dwell time at deceleration               | 0 ~ 360.0s  | 0.5s          | 149        |
| P.234            | 10-23 | Triangular wave function selection       | 0: None.  | 0             | <u>151</u> |
|                  |       |  | 1: External TRIs turned on, triangular wave function will be valid.   |               |            |
|                  |       |  | 2: The triangular wave function is effective at any given time.   |               |            |
| P.235            | 10-24 | Maximum amplitude                        | 0 ~ 25.0%   | 10.0%         | 151        |
| P.236            | 10-25 | Amplitude compensation for deceleration  | 0 ~ 50.0%   | 10.0%         | <u>151</u> |
| P.237            | 10-26 | Amplitude compensation for acceleration  | 0 ~ 50.0%   | 10.0%         | <u>151</u> |
| P.238            | 10-27 | Amplitude acceleration time              | 0 ~ 360.00s/0 ~ 3600.0s   | 10.00s        | <u>151</u> |
| P.239            | 10-28 | Amplitude deceleration time              | 0 ~ 360.00s/0 ~ 3600.0s   | 10.00s        | <u>151</u> |
| P.240            | 02-07 | Auxiliary frequency                      | 0: No auxiliary frequency function is available.  | 0             | 77         |
|                  |       |  | 2: operation frequency = basic frequency + auxiliary frequency (given by the 3-5 terminal)  |               |            |
|                  |       |  | 4: operation frequency = basic frequency - auxiliary frequency (given by the 3-5 terminal)  |               |            |
|                  |       |  | 6: Operation frequency = 3-5 terminal linkage signal given as a percentage  |               |            |
| P.242            | 10-05 | DC injection brake function before start | 0: DC injection brake function is not available before starting.  | 0             | <u>143</u> |
|                  |       |  | 1: DC brake injection function is selected before starting.   |               |            |
| P.243            | 10-06 | DC injection brake time before start     | 0 ~ 60.0s   | 0.5s          | <u>143</u> |
| P.244            | 10-07 | DC injection brake voltage before start  | 0 ~ 30.0%   | 4.0%          | <u>143</u> |
| P.245            | 06-12 | Cooling fan operation                    | 0: The fan will be turned on when running. The fan will be turned off 30 seconds after inverter stops.  | 1             | 112        |
|                  |       |  | 1: Turning on the power will turn on the fan. When the power is turned off, the fan will be off, too.   |               |            |
|                  |       |  | 2: The fan will be turned on when the temperature of the heat sink is higher than 60°C. When it is lower than 40°C, the fan will be turned off. |               |            |
|                  |       |  | 3: The fan will be turned on when the temperature of the heat sink is higher than 60°C and it will be turned off when it is lower than 40°C.    |               |            |

| Parameter Number | Group | Name  | Setting Range  | Factory Value | Page                |
|------------------|-------|---|--|---------------|---------------------|
| P.255            | 01-36 | S pattern time at the beginning of acceleration | 0 ~ 25.00s/0 ~ 250.0s  | 0.20s         | 73                  |
| P.256            | 01-37 | S pattern time at the end of acceleration       | 0 ~ 25.00s/0 ~ 250.0s<br>99999: Not selected   | 99999         | 73                  |
| P.257            | 01-38 | S pattern time at the beginning of deceleration | 0 ~ 25.00s/0 ~ 250.0s<br>99999: Not selected   | 99999         | 73                  |
| P.258            | 01-39 | S pattern time at the end of deceleration       | 0 ~ 25.00s/0 ~ 250.0s<br>99999: Not selected   | 99999         | 73                  |
| P.259            | 00-09 | Speed unit selection                            | 0: Speed display selection unit is 1<br>1: Speed display selection unit is 0.1   | 1             | 53                  |
| P.260            | 06-10 | Over torque detection selection                 | 0: The OL2 alarm is not reported after the over torque detection, and the inverter keeps running.<br>1: The OL2 alarm is reported after the over torque detection, and the inverter stops. | 1             | 111                 |
| P.261            | 06-17 | Maintenance alarm function                      | 0: No maintenance alarm.<br>1~9998day: Used to set time when maintenance alarm sends out signal  | 0             | 112                 |
| 06-18            | P.280 | Startup of short circuit test                   | 0 : Start without detection of short circuit<br>1 : Detection of short circuit when it is started  | 0             | <a href="#">112</a> |
| 06-19            | P.282 | GF in the operation of the testing standard     | 0 ~ 100%   | 50.0%         | <a href="#">112</a> |
| P.286            | 13-03 | High frequency vibration inhibition factor      | 0 ~ 15   | 0             | 155                 |
| P.288            | 06-40 | Alarm code query                                | 0 ~ 12   | 0             | <a href="#">113</a> |
| P.289            | 06-41 | Alarm code display                              | Read   | Read          | <a href="#">113</a> |
| P.290            | 06-42 | Alarm message query                             | 0 ~ 12   | 0             | <a href="#">113</a> |
| P.291            | 06-43 | Alarm message display                           | Read   | Read          | <a href="#">113</a> |
| P.292            | 06-27 | Accumulative motor operation time (minutes)     | 0 ~ 1439min  | 0min          | <a href="#">113</a> |
| P.293            | 06-28 | Accumulative motor operation time (days)        | 0 ~ 9999day  | 0day          | <a href="#">113</a> |
| P.294            | 00-04 | Decryption parameter                            | 0~65535  | 0             | 50                  |
| P.295            | 00-05 | Password setup                                  | 2~65535  | 0             | 50                  |

Appendix 1 Parameter table

| Parameter Number | Group | Name   | Setting Range  | Factory Value        | Page                |
|------------------|-------|--|--|----------------------|---------------------|
| P.296            | 06-29 | Accumulative motor power time (minutes)                    | 0 ~ 1439min  | 0min                 | <a href="#">113</a> |
| P.297            | 06-30 | Accumulative motor power time (days)                       | 0 ~ 9999day  | 0day                 | <a href="#">113</a> |
| P.300            | 00-21 | Motor control mode selection                               | 0: Induction motor V/F control                                       | 0                    | 57                  |
|                  |       |  | 1: reserved  |                      |                     |
|                  |       |  | 2: IMgeneral magneticvector control                                  |                      |                     |
| P.301            | 05-00 | Motor parameter auto-tuning function selection             | 0: Parameter auto-tuning function with no motor                      | 0                    | 104                 |
|                  |       |  | 1: Induction motor parameter auto-tuning measuring the running motor |                      |                     |
|                  |       |  | 2: Induction motor parameter auto-tuning measuring the stopped motor |                      |                     |
|                  |       |  | 3: Induction motoronline auto-tuning function                        |                      |                     |
| P.302            | 05-01 | Motor rated power  | 0 ~ 160.00kW   | 0.00kW               | 106                 |
| P.303            | 05-02 | Motor poles  | 0 ~ 8  | 4                    | 106                 |
| P.304            | 05-03 | Motor rated voltage  | 50Hz/60Hz system: 0 ~ 440V/0~220V                                    | According to voltage | 106                 |
| P.305            | 05-04 | Motor rated frequency                                      | 50Hz system: 0 ~ 650.00Hz  | 50.00Hz              | 106                 |
|                  |       |  | 60Hz system: 0 ~ 650.00Hz  | 60.00Hz              |                     |
| P.306            | 05-05 | Motor rated current  | 0~500.00A  | According to type    | 106                 |
| P.307            | 05-06 | Motor rated rotation speed                                 | 50Hz system: 0 ~ 9998r/min   | 1410 r/min           | 106                 |
|                  |       |  | 60Hzsystem: 0 ~ 9998r/min  | 1710 r/min           |                     |
| P.308            | 05-07 | Motor excitation current                                   | 0~500.00A  | According to type    | 106                 |
| P.309            | 05-08 | IM motor stator resistance                                 | 0 ~ 99.98Ω   | According to type    | 106                 |
| P.320            | 11-00 | Slip compensation gain                                     | 0 ~ 200%   | 85%                  | <a href="#">154</a> |
| P.321            | 11-01 | Torque compensation filter coefficients                    | 0 ~ 32   | 20                   | <a href="#">154</a> |
| P.322            | 11-02 | First set of current filter cutoff frequency point of time | 0~30.00Hz  | 4.00Hz               | <a href="#">154</a> |
| P.323            | 11-03 | First set of current filtering time                        | 0~400.00ms   | 20.00ms              | <a href="#">154</a> |
| P.324            | 11-04 | Second group of current filter time at low frequency       | 0~400.00ms   | 1.00ms               | <a href="#">154</a> |
| P.325            | 11-05 | Second group of current filtering time                     | 0~400.00ms   | 36.00ms              | <a href="#">154</a> |

| Parameter Number | Group               | Name                           | Setting Range  | Factory Value | Page |
|------------------|---------------------|--------------------------------|--|---------------|------|
| 15-00            | P.900               | User registration parameter 1  | P parameter model : 0 ~ 321<br>Parameter groups pattern : 00-00~13-03  | 99999         | 157  |
| 15-01            | P.901               | User registration parameter 2  |  | 99999         |      |
| 15-02            | P.902               | User registration parameter 3  |  | 99999         |      |
| 15-03            | P.903               | User registration parameter 4  |  | 99999         |      |
| 15-04            | P.904               | User registration parameter 5  |  | 99999         |      |
| 15-05            | P.905               | User registration parameter 6  |  | 99999         |      |
| 15-06            | P.906               | User registration parameter 7  |  | 99999         |      |
| 15-07            | P.907               | User registration parameter 8  |  | 99999         |      |
| 15-08            | P.908               | User registration parameter 9  |  | 99999         |      |
| 15-09            | P.909               | User registration parameter 10 |  | 99999         |      |
| 15-10            | P.910               | User registration parameter 11 |  | 99999         |      |
| 15-11            | P.911               | User registration parameter 12 |  | 99999         |      |
| 15-12            | P.912               | User registration parameter 13 |  | 99999         |      |
| 15-13            | P.913               | User registration parameter 14 |  | 99999         |      |
| 15-14            | P.914               | User registration parameter 15 |  | 99999         |      |
| 15-15            | P.915               | User registration parameter 16 |  | 99999         |      |
| 15-16            | P.916               | User registration parameter 17 |  | 99999         |      |
| 15-17            | P.917               | User registration parameter 18 |  | 99999         |      |
| 15-18            | P.918               | User registration parameter 19 |  | 99999         |      |
| 15-19            | P.919               | User registration parameter 20 |  | 99999         |      |
| 00-25            | P.990               | Parameter mode setting         | 0: Parameter is displayed as "group mode"<br>1: Parameter is displayed as "conventional P mode"  | 1             | 59   |
| 00-02            | P.996<br>~<br>P.999 | Parameter restoration          | 0: Non-function<br>1: Alarm history clear (P.996=1)<br>2: Inverter reset (P.997=1)<br>3: Restoring all parameters to default values (P.998=1)<br>4: Restoring some parameters to default values1 (P.999=1)<br>5: Restoring some parameters to default values 2 (P.999=2)<br>6: Restoring some parameters to default values3(P.999=3) | 0             | 48   |

## 7.2 Appendix 2 Alarm code list

| Code   | Screen display | Cause  | Troubleshooting   |
|--|----------------|--|---|
| <b>ERROR</b>                                   | <i>Error</i>   | <ol style="list-style-type: none"> <li>Under-voltage for power supply</li> <li>The reset function "RES" is on</li> <li>Bad connection between the operation panel and main machine</li> <li>Internal circuit malfunction</li> <li>Wrong CPU operation</li> </ol> | <ol style="list-style-type: none"> <li>Provide a normal power supply</li> <li>Shut off "RES"</li> <li>Ensure firm connection between the operation panel and the main machine</li> <li>Replace the inverter.</li> <li>Restart the inverter</li> </ol>   |
| <b>OC0</b><br>Over-current when stop           | <i>OC0</i>     | The output current is two times larger than the rated current of the inverter.   | Please restart the inverter. If the alarm repeated, please send the inverter back to the factory.   |
| <b>OC1</b><br>Over-current during acceleration | <i>OC1</i>     |  | <ol style="list-style-type: none"> <li>In case the time for acceleration or deceleration is too short, extend it as necessary.</li> <li>Avoid abrupt increase of load.</li> <li>Check Terminals U/T1, V/T2 and W/T3 for short circuit.</li> </ol>   |
| <b>OC2</b><br>Over-current at constant speed   | <i>OC2</i>     |  |   |
| <b>OC3</b><br>Over-current during deceleration | <i>OC3</i>     |  |   |
| <b>OV0</b><br>Over-voltage when stop           | <i>OV0</i>     | Over-voltage between Terminals P and PR.   | Check whether the power supply is normal or abnormal.   |
| <b>OV1</b><br>Over-voltage during acceleration | <i>OV1</i>     |  | <ol style="list-style-type: none"> <li>In case the time for acceleration or deceleration is too short, extend it as necessary.</li> <li>Check the brake resistor between Terminals +/P and PR for loose connection.</li> <li>Check whether the values of 06-05(P.30) and 06-06(P.70) are correct or not.</li> </ol> |
| <b>OV2</b><br>Over-voltage at constant speed   | <i>OV2</i>     |  |   |
| <b>OV3</b><br>Over-voltage during deceleration | <i>OV3</i>     |  |   |

| Code  | Screen display | Cause   | Troubleshooting   |
|---|----------------|---|---|
| <b>THT</b><br>IGBT module<br>overload             | <b>THT</b>     | IGBT module thermal<br>accumulation relay operation   | Avoid prolonged inverter operation when<br>overloaded.  |
| <b>THN</b><br>Motor overload                      | <b>THN</b>     | Electronic thermal relay operation  | 1. Check whether the set value of<br>06-00(P.9) is correct or not<br>(according to the externally<br>connected motor).<br>2. Reduce load.   |
| <b>OHT</b><br>External thermal<br>relay operation | <b>OHT</b>     | External thermal relay operation  | 1. Check whether the capacity of the<br>external thermal relay and of the<br>motor coordinates well.<br>2. Reduce the load.   |
| <b>OPT</b><br>Abnormal<br>peripheral<br>devices   | <b>OPT</b>     | 1. Abnormal communication;<br>Exceeding the number of<br>communication retries<br>2. Interrupted communication;<br>Exceeding the permitted<br>communication time interval | Correctly set the communication<br>parameters.  |
| <b>EEP</b><br>Abnormal<br>memory                  | <b>EEP</b>     | ROM malfunction   | Send the inverter back to the factory if this<br>type of alarm happens frequently.  |
| <b>PIDE</b><br>Abnormal PID                       | <b>PIDE</b>    | 1. Insufficient inverter and<br>motor capacity<br>2. PID target value or feedback<br>value set unreasonably<br>3. Peripheral devices<br>malfunction                       | 1. Enlarge the inverter and motor<br>capacity.<br>2. Check the feedback gain setup.<br>Reset the target value according to<br>the feedback.<br>3. Check the system's peripheral<br>feedback devices (e.g., sensors,<br>potentiometer) and whether the<br>wiring is correct. |
| <b>CPU</b><br>Abnormal CPU                        | <b>CPU</b>     | Serious peripheral<br>electromagnetic interference  | Reduce peripheral interference.   |
| <b>OLS</b><br>Stall prevention<br>and protection  | <b>OLS</b>     | Over-load   | 1. Reduce motor load.<br>2. Increase 06-01(P.22) value.   |

Appendix 2 Alarm code list

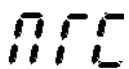
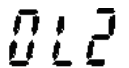
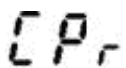
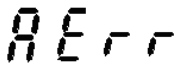
| Code                                    | Screen display  | Cause  | Troubleshooting   |
|---|---|--|---|
| <b>NTC</b><br>Overheated<br>module      |  | The temperature of the inverter IGBT module is too high.                 | 1. Reduce the environment temperature and improve the air condition.<br>2. Check whether the fan of the inverter is running normally. |
| <b>OL2</b><br>Abnormal<br>over-torque   |  | 1. Over-loaded motor<br>2. 06-08(P.155), 06-09 (P.156) set unreasonably. | 1. Reduce motor load.<br>2. Adjust the set value of 06-08(P.155), 06-09(P.156) properly.  |
| <b>CPR</b><br>CPU abnormal              |  | CPU software abnormal  | 1. Check the wiring.<br>2. Check the parameter setting.<br>3. Improve external disturbance.   |
| <b>AErr</b><br>3-5 terminal<br>abnormal |  | 3-5 terminal signal loss detected  | Please see the parameters 02-24 (P. 184)  |

## 7.3 Appendix 3 Troubles and solutions

| Troubles  | Check points   |  |
|---|--|--|
| Motionless motor                                    | Main circuit   | <ul style="list-style-type: none"> <li>•Check whether the power supply voltage between Terminals R/L1, S/L2 and T/L3 is normal.</li> <li>•Check whether the Power light is on.</li> <li>•Check whether the wiring between the inverter and the motor is correct.</li> </ul>  |
|   | Load   | <ul style="list-style-type: none"> <li>•Check whether the load is too heavy.</li> <li>•Check whether the motor rotor is locked.</li> </ul>   |
|   | Parameters Setting   | <ul style="list-style-type: none"> <li>•Check whether the starting frequency (01-11(P.13)) is set too big.</li> <li>•Check whether the operation mode (00-16(P.79)) is correct.</li> <li>•Check whether the maximum frequency (01-00(P.1)) is zero.</li> <li>•Check whether the reverse rotation prevention (00-15(P.78)) is restricted.</li> <li>•Check whether the bias and gain (02-25~02-28) setting is correct.</li> <li>•Check that the frequency jump (01-16~01-21 / P.91~P.96) setting is correct.</li> </ul>  |
|   | Control circuit  | <ul style="list-style-type: none"> <li>•Check whether the output stop signal "MRS" is ON. (Related parameter 03-00, 03-01, 03-03, 03-04)</li> <li>•Check whether the "RES" function is ON. (Related parameter 03-00, 03-01, 03-03, 03-04)</li> <li>•Check whether the external thermal relay is operating or not.</li> <li>•Check whether the reset has been performed or not after the set-off of the alarm (the ALARM light is on).</li> <li>•Check whether the voltage/current signals are correctly wired.</li> <li>•Check whether the functions of STF and STR are correct. (Related parameter 03-00, 03-01, 03-03, 03-04)</li> <li>•Check whether the wiring for the control circuit is disconnected or has a poor contact.</li> </ul> |
| Reversed motor rotation                             | <ul style="list-style-type: none"> <li>•Check whether the phase sequence of output terminals U/T1, V/T2 and W/T3 is correct.</li> <li>•Check whether the start signal (STF and STR) are connected correctly.</li> </ul>  |  |
| Failure to increase the rotation speed of the motor | <ul style="list-style-type: none"> <li>•Check whether the load is too heavy.</li> <li>•Check whether the stall prevention level (06-01(P.22)) is correct.</li> <li>•Check whether the torque boost (01-10(P.0)) is set too high.</li> <li>•Check whether the maximum frequency (01-00(P.1)) is effective.</li> </ul>             |  |
| Unsmoothed acceleration / deceleration              | <ul style="list-style-type: none"> <li>•Check whether the acceleration / deceleration time (01-06(P.7), 01-07(P.8)) is correct.</li> <li>•Check whether the acceleration / deceleration curve selection (01-05(P.29)) is correct.</li> <li>•Check whether the voltage / current input signals are affected by noises.</li> </ul> |  |
| Overlarge motor current                             | <ul style="list-style-type: none"> <li>•Check whether the load is too heavy.</li> <li>•Check whether the capacity of the inverter and of the motor are well matched.</li> <li>•Check whether the torque boost (01-10(P.0)) is set too high.</li> </ul>   |  |
| Speed variation during the operation                | <ul style="list-style-type: none"> <li>•Check whether the voltage / current input signals are affected by noises.</li> <li>•Check whether the load varies.</li> <li>•Check whether the wiring length of the main circuit is too long.</li> </ul>   |  |

## 7.4 Appendix 4 : Optional accessories

### 7.4.1 PU301Parameter Unit

➤ PU301external view

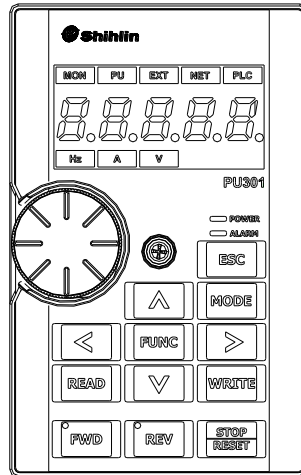

Description on the ordering code:

| NO. | Model | Item Name          | Ordering Code |
|-----|-------|--------------------|---------------|
| 1   | PU301 | LED Parameter Unit | SNKPU301      |

➤ outline dimensional drawing

<Outline drawing>

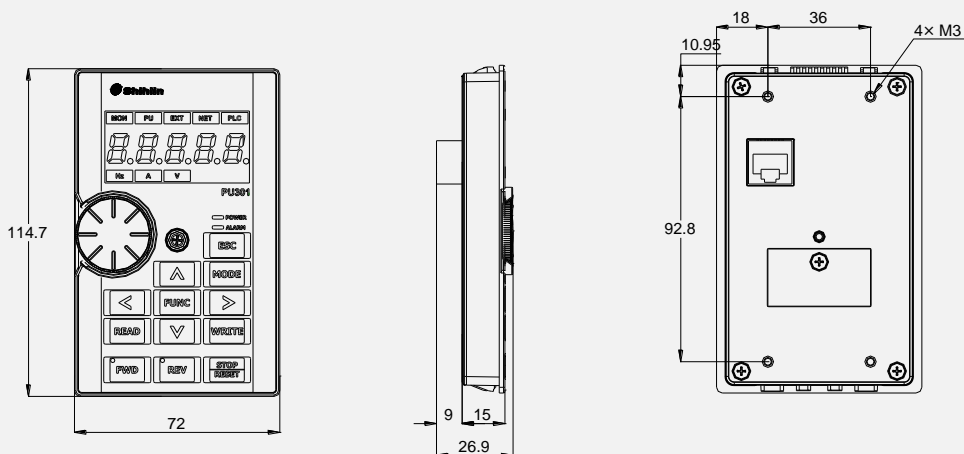

➤ Surface mounting hole size figure

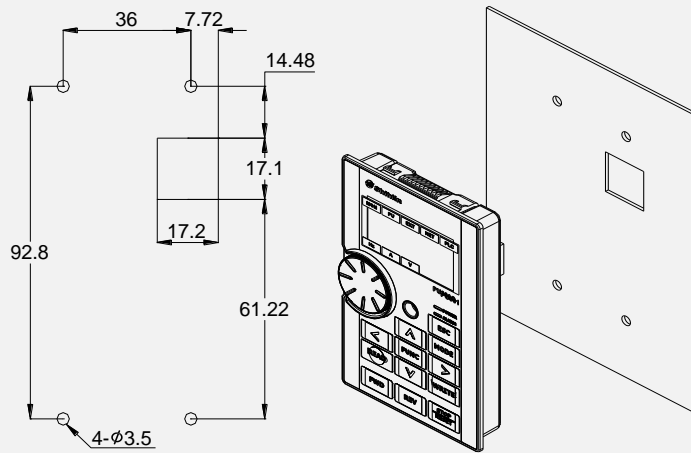

➤ Card buckle installation hole size chart

<Card buckle installation: panel cutting dimension drawing>

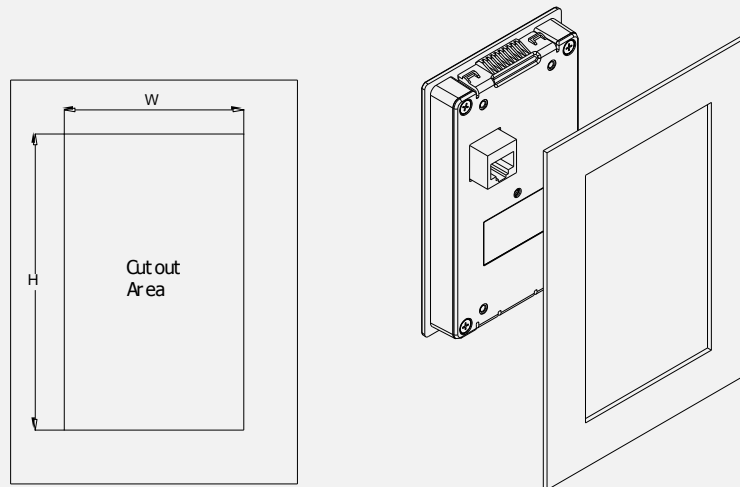

| plate thickness | 1.2mm | 1.6mm | 2.0mm |
|-----------------|-------|-------|-------|
| W               | 66.4  |       |       |
| H               | 110.2 | 111.3 | 112.5 |

\*allowable error:±0.15mm

\*If the customer open hole precision can't satisfy the allowable error, please choose and buy accessories SMK301 for installation.

7.4.2 DU06 operation panel

➤ DU06 external view

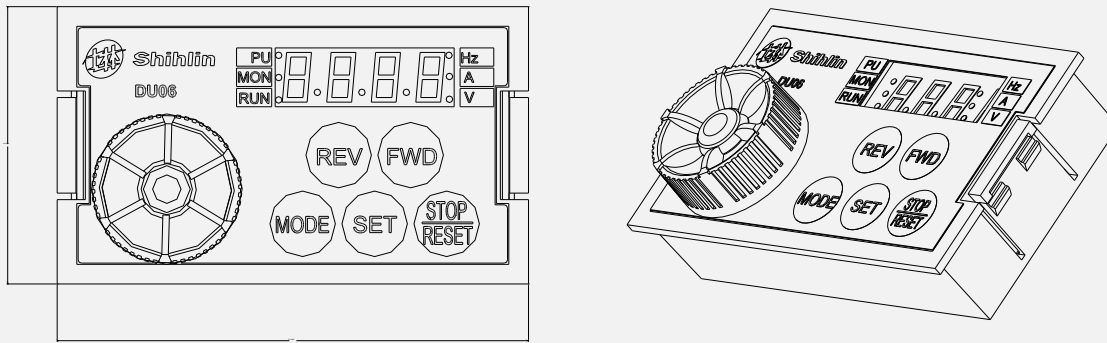

Description on the ordering code:

| NO. | Model | Item Name           | Ordering Code |
|-----|-------|---------------------|---------------|
| 1   | DU06  | DU06operation panel | SNKDU06       |

➤ outline dimensional drawing

<Outline drawing>

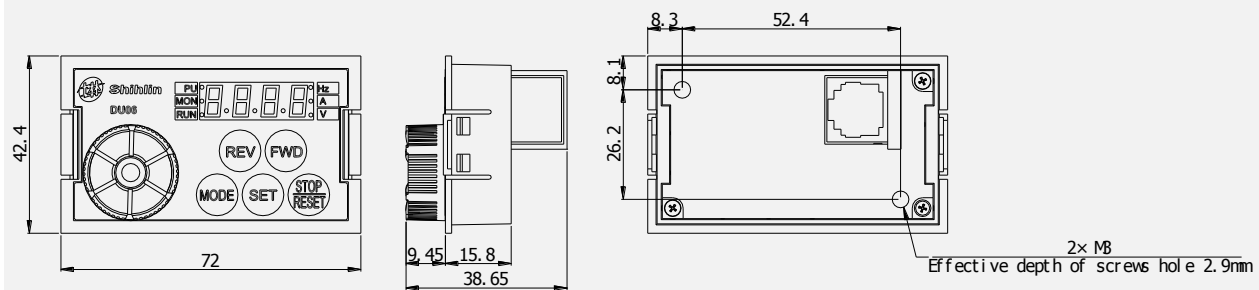

➤ Outline drawing of DU06

<Screw installation: panel cutting dimension drawing>

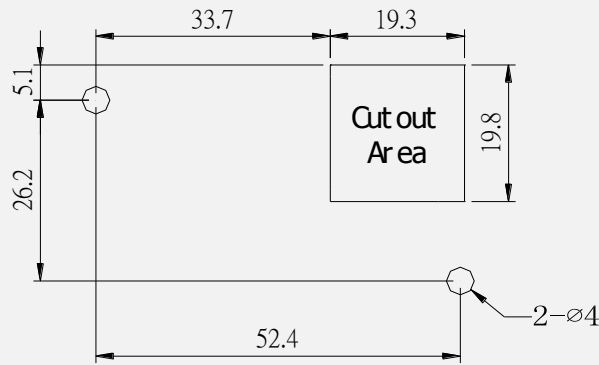

➤ Snap-fit installation of DU06

<Snap-fit installation: panel cutting dimension drawing>

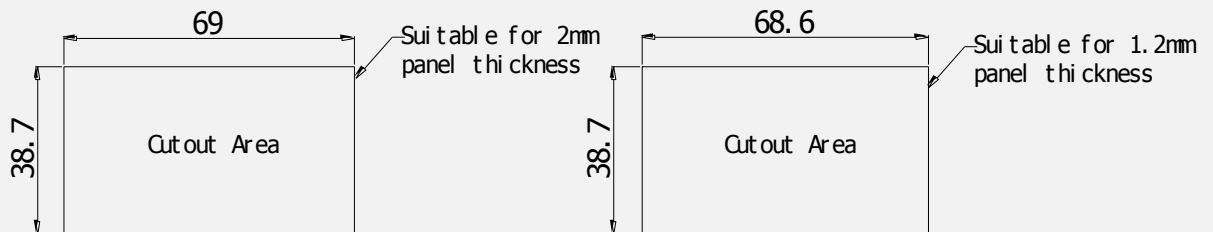

7.4.3 DU08 operation panel

➤ DU08 External view

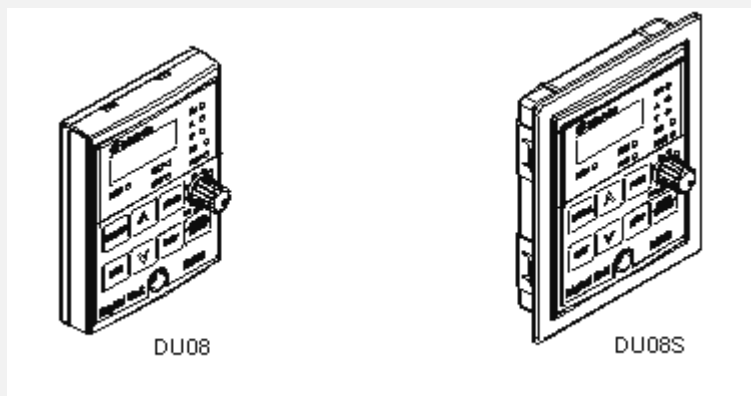

Description on the ordering code:

| NO. | Model | Item Name            | Ordering Code |
|-----|-------|----------------------|---------------|
| 1   | DU08  | DU08operation panel  | SNKDU08       |
| 2   | DU08S | DU08Soperation panel | SNKDU08S      |

Note: DU08, DU08S for SS2 series inverter, DU09, DU09S applicable to SF-G series inverter V0.320 and above version (version identifiers corresponding -02 and above).

➤ Outline drawing of DU08

<Outline dimensional drawing>

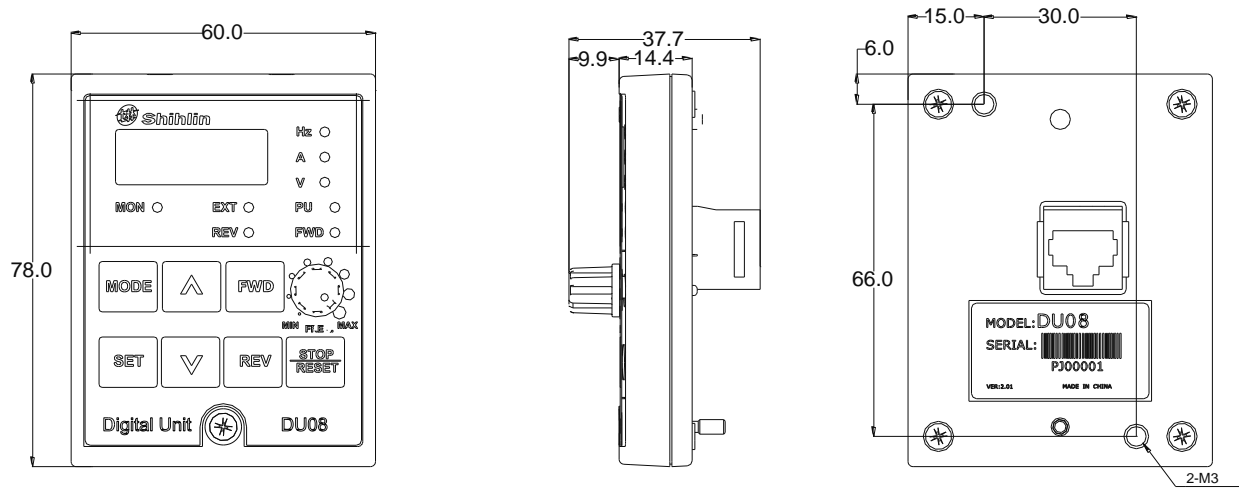

< Surface mounting hole size figure>< Flange installation hole size chart (note)>

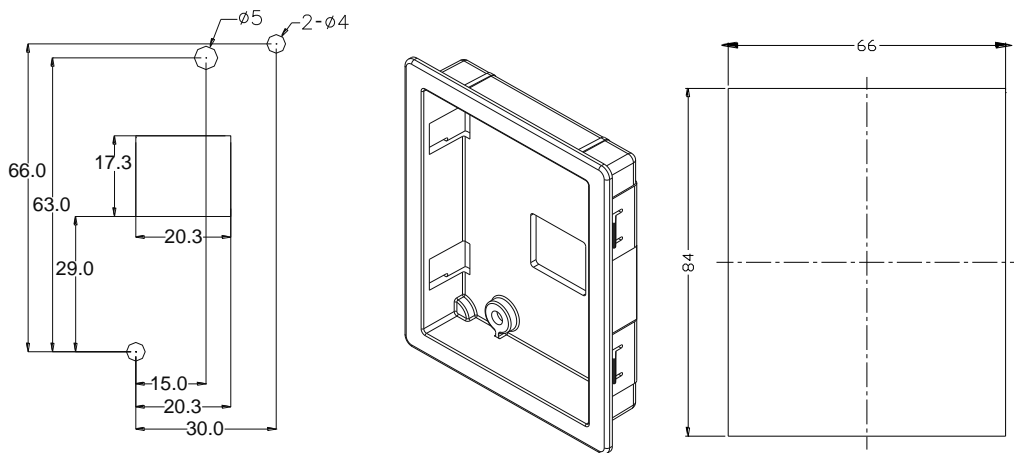

Note: the flange installation, installation of the base is not standard, need to purchase another, order code: SNKDUMH02 (DU08S already includes the installation of the base).

7.4.4 DU10operation panel

➤ DU10external view

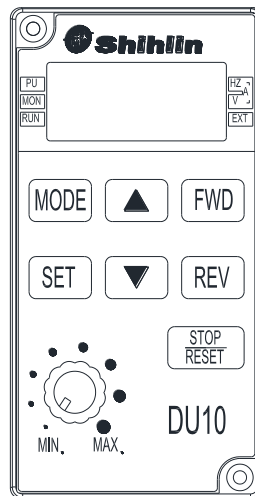

Description on the ordering code:

| NO. | Model | Item Name           | Ordering Code |
|-----|-------|---------------------|---------------|
| 1   | DU10  | DU10operation panel | SNKDU10       |

➤ Outline drawing of DU10

<Outline dimensional drawing>

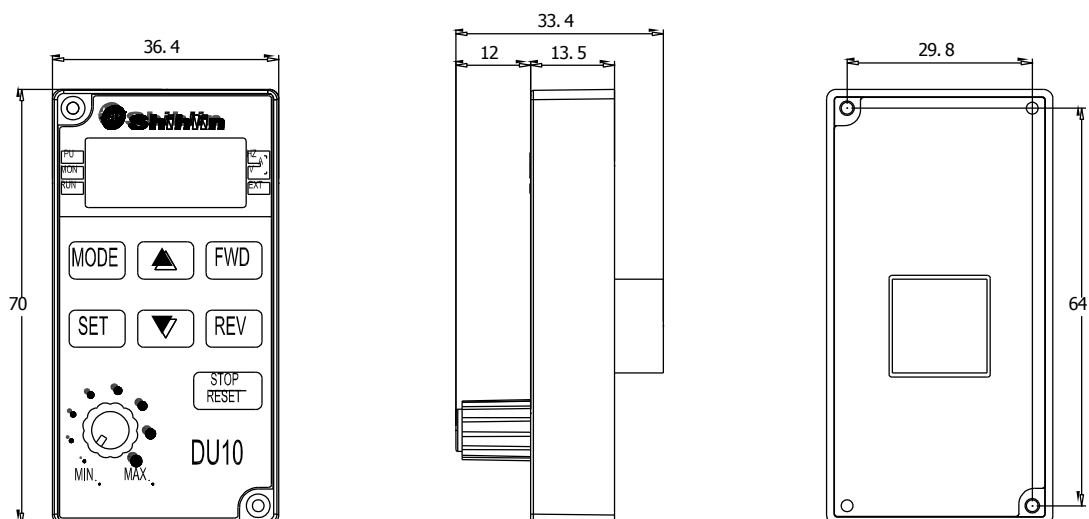

7.4.5 CBL: Data transmission line (coordinated with the operation panel)

Model: SNKCBLxxGTN2 (xx expression 1R5, 3, 5, 10)

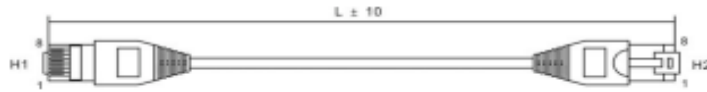

| Item No. | Part No.      | L(mm) |
|----------|---------------|-------|
| 1        | SNKCBL1R5GTN2 | 1500  |
| 2        | SNKCBL3GTN2   | 3000  |
| 3        | SNKCBL5GTN2   | 5000  |
| 4        | SNKCBL10GTN2  | 10000 |

## 7.5 Appendix 6 European Specification Compatibility Description

### **This inverter qualifies the CE label. Specifications:**

#### **Low Voltage Directive 2006/95/EC & Electromagnetic Compatibility Directive 2004/108/EC.**

#### 1. Electromagnetic compatibility command (EMC):

##### (1). EMC compatibility description:

For system integration, inverter is not a functionally independent device unit. It is usually a unit in the control box. It is combined with other devices to control a machine or equipment. Therefore, our company does not consider that all the EMC commands should be directly applied on the inverter. As a result, the CE label of this inverter is not extensible.

##### (2). Compatibility:

The inverter does not need to cover all the EMC commands. Yet, for certain machine equipment that needs to use EMC commands and the inverter, the machine has to be equipped with CE label. In addition, the company can provide the electromagnetic inspection data and operation manual that covers the required electromagnetic compatibility specifications for a quick and easy installation of the machine equipment of this inverter.

##### (3). Installation outline:

Please follow the following notes for installing the inverter:

\*Use a noise filter qualifying the EU standard to coordinate with the inverter.

\*The wire between the motor and the inverter has to be stored in shielded cable or metal tube. In addition, ground the motor terminal and the inverter terminal together. Please shorten the wire as much as possible.

\*Please put this inverter in a metal cabinet that is already grounded. It can prevent radiation interference.

\*The line-to-line noise filter at the power source terminal and the online magnetic iron core at the control row are used for suppressing noises.

All the signals and the EU-qualified filter specifications are described in details in the operation manual. Please contact your agent.

#### 2. Low-voltage command (LVD):

##### (1). Low-voltage command compatibility description:

This inverter is compatible with low-voltage commands.

##### (2). Compatibility:

Our company qualifies the low-voltage command specification.

##### (3). Description:

\*Do not rely on leakage protection only for preventing electric shocks. Grounding is required for the protection.

\*Ground each inverter individually (do not connect more than two (including two) ground cables).

\*Please use non-fuse switch and electromagnetic contactor that qualify EN or IEC specifications.

\*Please use the inverter under an environment of over-voltage level-2 condition with contamination level 2 or better.

\*For the style and dimensions of the input- and output-end of the inverter cable, please refer to the specifications listed in the operation manual.



## VERIFICATION OF CONFORMITY

CERTIFICATE NO: VC-0398/01/03

|   |              |  |  |
|---|--------------|--|--|
| <b>Applicant</b>  | Name         | :  | Shihlin Electric & Engineering Corporation Automation Business Group |
|   | Address      | :  | No.234, Chung Lun, Hsin Fun, HsinChu, Taiwan                         |
| <b>Manufacturers</b>  | Name         | :  | Shihlin Electric & Engineering Corporation Automation Business Group |
|   | Address      | :  | No.234, Chung Lun, Hsin Fun, HsinChu, Taiwan                         |
|   | Name         | :  | Suzhou Shihlin Electric & Engineering Corporation                    |
|   | Address      | :  | No.88, Guangdong St., Suzhou New District, Jiangsu, China.           |
| <b>Test Report No.:</b><br><small>(Refer to Annex II for details)</small> | Trader Mark  | :  |  |
|   | Product Name | :  | INVERTER   |
|   | Model        | :  | Refer to Annex I for details   |
| <b>Applicable Directives</b>  | :            | LOW VOLTAGE DIRECTIVE 2006/95/EC<br>ELECTROMAGNETIC COMPATIBILITY 2004/108/EC  |  |
| <b>Applicable Standards</b>   | :            | EN 61800-5-1:2007, EN 61800-3:2004/A1:2012, EN 61000-4-2:2009,<br>EN 61000-4-3:2006+A2:2010, EN 61000-4-4:2004, EN 61000-4-5:2006,<br>EN 61000-4-6:2009, EN 61000-4-8:2010 |  |

VIACERT as the Third Party Authority, upon the relevant request of **Shihlin Electric & Engineering Corporation** and **Suzhou Shihlin Electric & Engineering Corporation**, certifies that: the test results of the above mentioned products comply with the requirement of the EN Standards, according to EU Low Voltage Directive 2006/95/EC and Electromagnetic Compatibility 2004/108/EC.

The manufacturer is obliged to issue a Declaration of Conformity according to the basic requirement of relative Directives and places the CE marking with his own responsibility as follows:



All modifications to the Technical File should be first submitted to the Third Party Inspection Authority to ensure further validity of this attestation.

Third Party Authority Stamp



|                         |
|-------------------------|
| Date and Place of Issue |
| Shanghai, 18/01/2016    |
| FOR VIACERT             |
|                         |
| KELVIN GAO              |
| GENERAL MANAGER         |

VIACERT TESTING & CERTIFICATION  
Room 211, 4# Building, No.641 Tianshan Road, Shanghai 200336, China

TEL:+86-21 51088618, FAX:+86-21 51801927  
EMAIL: info@via-cert.com

2 / 2



## VERIFICATION OF CONFORMITY

CERTIFICATE NO: VC-0398/01/03

Shihlin Electric & Engineering Corporation Automation Business Group  
Suzhou Shihlin Electric & Engineering Corporation

### Annex I - INVERTER MODEL LIST

|                                       |  |
|---------------------------------------|--|
| <b>SC3-043 Series<br/>(3PH 440V):</b> | SC3-043-0.4K-**, SC3-043-0.75K-**, SC3-043-1.5K-**,<br>SC3-043-2.2K-**, SC3-043-3.7K-**, SC3-043-5.5K-** |
| <b>SC3-023 Series<br/>(3PH 220V):</b> | SC3-023-0.2K-**, SC3-023-0.4K-**, SC3-023-0.75K-**,<br>SC3-023-1.5K-**, SC3-023-2.2K-**, SC3-023-3.7K-** |
| <b>SC3-021 Series<br/>(1PH 220V):</b> | SC3-021-0.2K-**, SC3-021-0.4K-**, SC3-021-0.75K-**,<br>SC3-021-1.5K-**, SC3-021-2.2K-**                  |
| ** denote any alphanumeric suffix     |  |

### Annex II – TEST REPORT NUMBERS LIST

|                                  |   |
|----------------------------------|---|
| <b>LVD TEST<br/>REPORT ISSUE</b> | VC-CO-20151001, VC-CO-20151002, VC-CO-20151003,<br>VC-CO-20151201, VC-CO-20151202, VC-CO-20151203 |
| <b>EMC TEST<br/>REPORT ISSUE</b> | 2015118A, 2015119A, 2015120A, 2015181A, 2015182A,<br>2015183A                                     |



Third Party Authority Stamp

VIACERT TESTING & CERTIFICATION  
Room 211, 4# Building, No.641 Tianshan Road, Shanghai 200336, China

TEL:+86-21 51088618, FAX:+86-21 51801927  
EMAIL: info@via-cert.com

## 8. REVISION RECORD

| Published Date | Edition of the Manual | Revision Content   |
|----------------|-----------------------|--|
| 2015.07        | V1.00                 | First Edition  |
| 2016.04        | V1.01                 | 1 : Added: the European standard compatibility<br>2 : Modified part of the parameter value and set the scope   |
| 2016.06        | V1.02                 | Amendment:<br>1. Modified the communication line in 7.4.4 specifications.<br>2. Modified the 3.1 electrical specifications in the individual model cooling way.<br>Added:<br>1. Added the 3.7.3 grounding torque form. |
| 2016.06        | V1.03                 | Added :<br>1. Added the 7.4.4 DU10 Exerciser.  |
| 2016.09        | V1.04                 | Added:<br>1. Added 1.3 P.XXX descriptions.<br>Amendment:<br>1. Modified 4.1 (d) V indicator descriptions.<br>2. Modified 3.1 inverter weight.  |
| 2016.10        | V1.05                 | Amendment:<br>1. Revised some errors<br>2. Modified the Operation flow charts of 4.2.2, 4.2.5 and 4.2.6<br>3. Deleted P.109 and P.550 relevant contents  |
| 2017.03        | V1.06                 | Added:<br>1. 5.7.7 Floor drain current protection<br>2. 5.11.3 Current filter<br>3.5.1.7 PWM Carrier frequency Increase the surface<br>Amendment:<br>1. Revised some errors<br>2.3.6.3 To delete A framework model     |

Version: V1.06