



MSystem

MICRO PANEL

GF0

Device description

GF0



micro  innovation

Micro Innovation AG · Spinnereistrasse 8-14 · CH-9008 St. Gallen · Switzerland
Tel. +41 (0)71 243 24 24 · Fax +41 (0)71 243 24 90
www.microinnovation.com · info@microinnovation.com

Copyright

Keep documentation for future use!

This documentation is the intellectual property of **Micro Innovation AG**, which also has the exclusive copyright. Any modification of the content, duplication or reprinting of this documentation, as well as distribution to third parties can only be made with the express permission of **Micro Innovation AG**.

Micro Innovation AG does not accept any liability for damages arising from the use of any incorrect or incomplete information contained in this documentation or any information missing therefrom.

Micro Innovation AG reserves the right to make complete or partial modification to this document.

All brand and product names are trademarks or registered trademarks of the owner concerned.

Proper use

Hardware, software, operatingsystems and drivers must only be used for the applications specified in this description and only in conjunction with the components recommended by Micro Innovation AG.

Warning !

No warranty claims will be recognized for faults arising from the improper handling of any device.

Devices and communication should not be used for the implementation of any safety functions relating to the protection of personnel and machinery.

No liability is accepted for claims for damages arising from a failure or functional defect.

All data specified in this document does not represent guaranteed specifications in the legal sense.

Contents

1	Explanation of symbols	6
2	Introduction	7
3	Device Versions	8
3.1	Scope of Delivery	8
4	Device mounting	9
4.1	General mounting instructions.....	9
4.2	Dimensions of the 5.7" devices	10
4.3	Front panel cutouts for 5.7" devices	11
4.4	Dimensions of the 10" devices	12
4.5	Front panel cutouts for 10" devices	13
5	Mounting instructions	14
5.1	Mounting (without special degree of protection).....	14
5.2	Mounting according to degree of protection IP 65.....	14
6	Connecting the system power supply	15
7	Connection to the communication interface	16
7.1	Preparing the connection cable (EMC).....	16
7.2	Preparing the shield connections	17
8	Connection and function of the programming port (PROG PORT)	18
9	Data transfer to the Micro Panel GF0 (Download button)	19
9.1	Loading the runtime (GRSW)	20
9.2	Loading the project data (Download).....	21
10	Communications Cards and COM SLOT	22
11	Expansion and configuration options	23
11.1	General requirements.....	23
11.2	Memory Expansion.....	23
11.3	Additional 5V power supply on programming port (PROG PORT).....	24
12	Function and control LEDs	25
13	Touch Screen	26
13.1	Prinzipielle Funktion des Touch-Screen.....	26
13.2	Power up function test.....	26
13.3	Cleaning and maintenance of the Touch Screen	26

14 Display	27
15 Maintenance and repair	28
16 Disposal	29
17 Technical data	30
18 EC Conformity	32
19 UL-Listing	33
20 Revision History	34

1 EXPLANATION OF SYMBOLS

Danger warnings

The following warnings are provided to ensure your personal safety and to protect the product described or connected devices from damage.

Safety instructions and warnings for the prevention of danger to the life and health of users or service personnel, as well as the prevention of damage to property are highlighted throughout this document by the following symbols. This document always shows different pictogrammes for "Warnings" and "Notes".

Warnings generally mean the following:

Indicates that death, serious injury or damage to property may occur if the relevant precautionary measures are not observed.

The individual Warning pictogrammes have the following meaning:



Caution ! General !

This type of warning must be observed in order to prevent hazards during the operation of the device and at other times. Observe the correct procedure.



Danger ! Electric shock !

Voltages may occur in electrical installations that may be dangerous to persons. The touching of live parts may cause electric shock.



Caution! Observe proper ESD protection measures !

Electrostatic discharge may destroy some components.

Notes generally mean the following:

This indicates important information on the product or section of the operating instructions to which special attention should be given.

The Note pictogramme has the following meaning:



Indicates important instructional information.

2 INTRODUCTION

The Micro Panel GF0 is a visualisation unit that is provided with touch zone functions for medium to high complexity automation systems. It meets all the requirements placed on a modern visualisation unit.

The Micro Panel GF0 must be loaded with the necessary project data before it can be used. The project data is created and loaded using a PC and the GALILEO design software for the GF series. This software is described in a separate documentation. The data transfer between the PC and the Micro Panel GF0 (Download) is implemented via a serial interface. The project data is then stored inside the device in a retentive memory.

The Micro Panel GF0 is provided with a slot for the communications card (→ Section 11) which manages the communication with the automation device. The communications cards are not described in this documentation. Refer to the relevant device descriptions for more information.

This device description should be used as a reference for the installation, connections, technical data, commissioning, operation and maintenance of all Micro Panel GF0 versions. The illustrations in this document are for the 10" version (→ Section 3) unless stated otherwise. The designation and function of the terminals and signals are the same, however, for all versions.

Device description GF0

MICRO PANEL

Device Versions

3 DEVICE VERSIONS

The Micro Panel GF0 units comes in different versions featuring different display technologies, flat screen display sizes and dimensions, as well as front plate material and device fastening.

Micro Panel Device Versions				
Type designation	Display size	Display technology	Resolution	Power supply
GF0-57CQD- xxy	5.7" (145 mm)	STN color	1/4-VGA (320 x 240)	24 VDC
GF0-57SQD- xxy	5.7" (145 mm)	STN mono	1/4-VGA (320 x 240)	24 VDC
GF0-57EQD- xxy	5.7" (145 mm)	EL mono	1/4-VGA (320 x 240)	24 VDC
GF0-10CVD- xxy	10.4" (264 mm)	STN color	VGA (640 x 480)	24 VDC
GF0-10SVD- xxy	10.4" (264 mm)	STN mono	VGA (640 x 480)	24 VDC

The following front plate versions are available:

Type of front plate (y)	xx0	Device types with 4-hole aluminium front (→ Section 4.1)
	xx1	Device types with corrosion-resistant stainless steel front 1.4301 (→ Section 4.1)
	xx2	Device types with customized front plate
	xx3	Device types with aluminium front and threaded bolts (→ Section 4.1)

3.1 SCOPE OF DELIVERY

The basic unit is supplied with the following components:

Device:			
Micro Panel GF0 with 4-hole aluminium front	GF0-xxxxx-xx0		
Micro Panel GF0 with corrosion-resistant stainless steel front 1.4301 and threaded bolts		GF0-xxxxx-xx1	
Micro Panel GF0 with aluminium front and threaded bolts			GF0-xxxxx-xx3
Assembly Kit:			
4 fixing screws countersunk for device mounting	•		
Seal for mounting the unit	•	•	•
Power supply plug connector (3-pole plug-in screw terminal, Phoenix, Type : MSTB 2.5/3-ST-5.08)	•	•	•
Device description	•	•	•

(See Section 3 for device description)

4 DEVICE MOUNTING

4.1 GENERAL MOUNTING INSTRUCTIONS

The Micro Panel GF0 is available in different versions depending on the type of mounting required.

The 4-hole aluminium front design (xx0) is suitable for mounting in an enclosure with a rear panel. The device is mounted directly from the front with countersunk screws. For proper mounting with all versions ensure that the front panel is sufficiently thick and that the mounting complies with the specifications as per (→ Section 5).

The Micro Panel GF0 version with an aluminium front and threaded bolts (xx3) and the version with a corrosion-resistant stainless steel front (xx1) are available for rear mounting. Ensure that sufficient space is provided for fastening.

After mounting the rear of the Micro Panel GF0 must be accessible (Download button→ Section 9).

All mounting versions allow protection in compliance with IP65 (→ Section 5.2).

The Micro Panel GF0 can be operated at an ambient temperature of up to 50°C (→ Section 17). The ambient temperature refers to the area directly in the vicinity of the lower cooling slits of a vertically mounted device provided with unhindered air convection and mounted at a location of no more than 2000 m above sea level. The cooling slits must always be kept clear to ensure the proper cooling of the system.

Mounting inside an enclosure is possible provided that the permissible ambient temperature is observed. A clearance of at least 30 mm from all sides of the enclosure must be observed in order to ensure sufficient air circulation.

Avoid exposing the flat screen to direct sunlight. The radiation from the sun (UV component) reduces the lifespan of the LCD display.

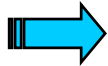

The cooling slits must be kept clear to ensure the proper cooling of the system.

Avoid exposing the flat screen to direct sunlight.

After mounting the rear of the device must be accessible (Download button).

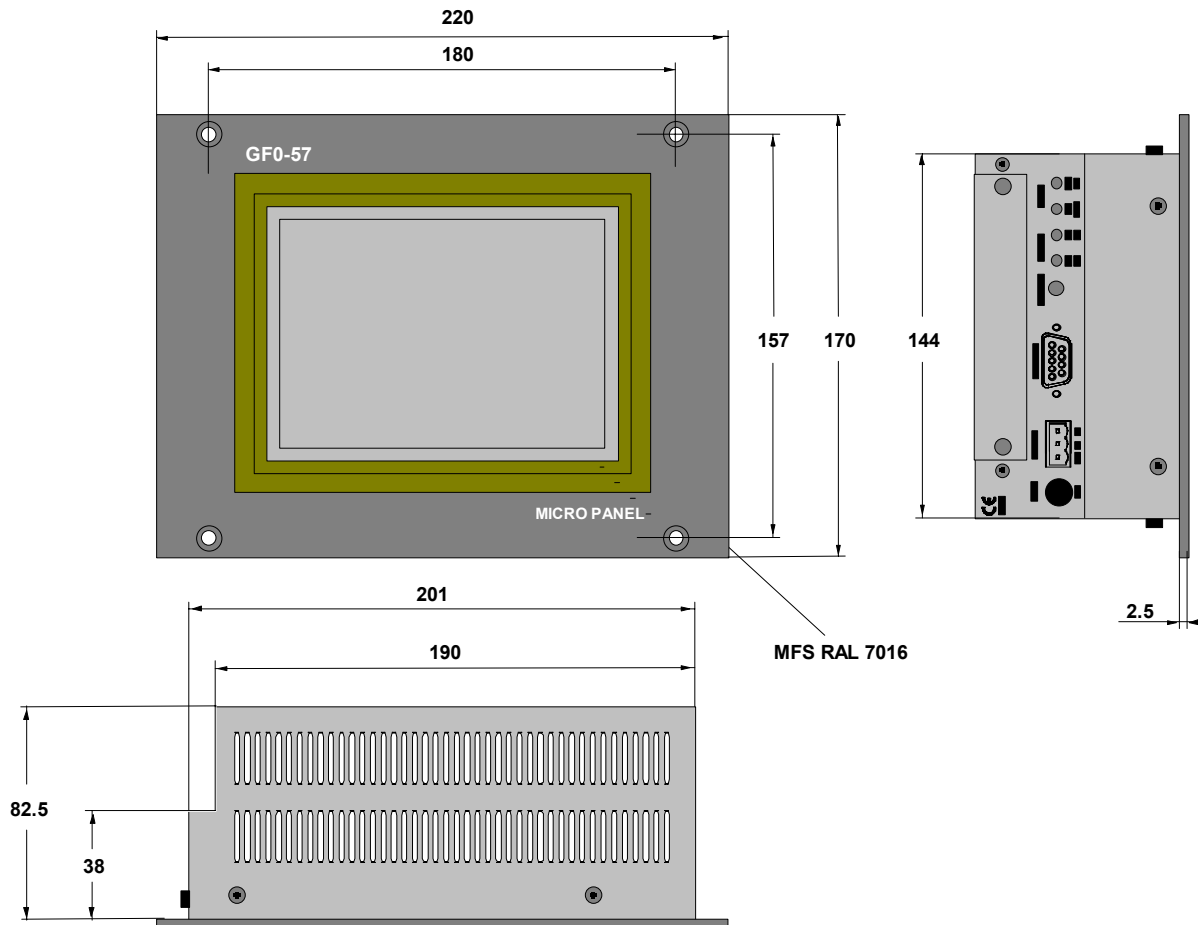
4.2 DIMENSIONS OF THE 5.7" DEVICES

The figure above shows the dimensions of the GF0-57xxx-xx0 devices. These units are provided with a four-hole aluminium front.

The devices with threaded bolts (-xx1, -xx3) have identical outer dimensions. The fixing hole patterns of the Micro Panel GF0 vary according to the version concerned.

Refer to the following section for the front panel cutouts of specific versions.

4.3 FRONT PANEL CUTOUTS FOR 5.7" DEVICES

Cutout and hole pattern for device versions with 4-hole aluminium front (-xx0)

Front panel cutout: **203x147mm** (centrally to fixing holes)

Fixing screws: **M4 countersunk screw**

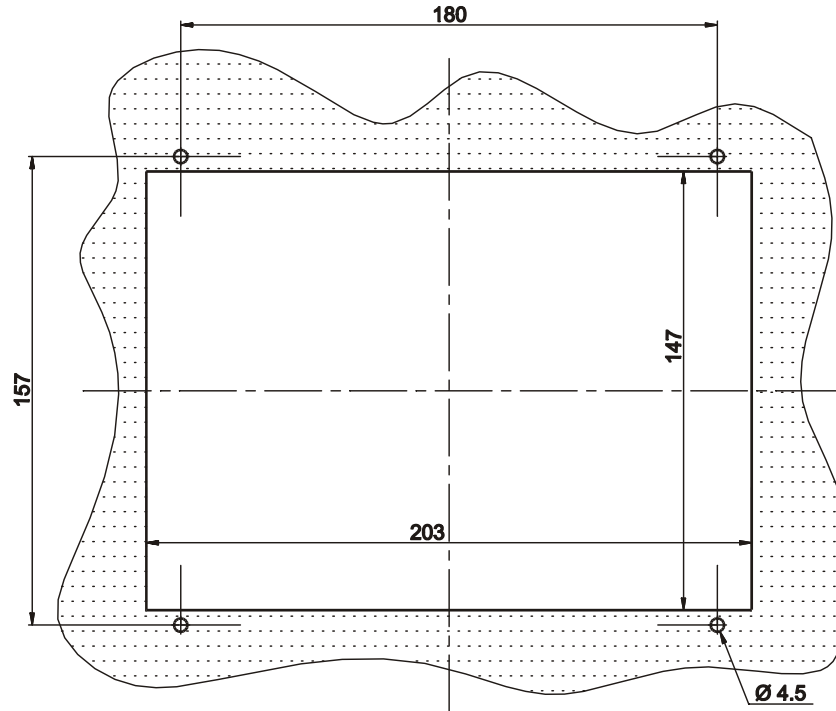

Cutout and hole pattern for device versions with front and threaded bolts (-xx1, -xx3)

Front panel cutout : **203x146mm** (centrally to fixing holes)

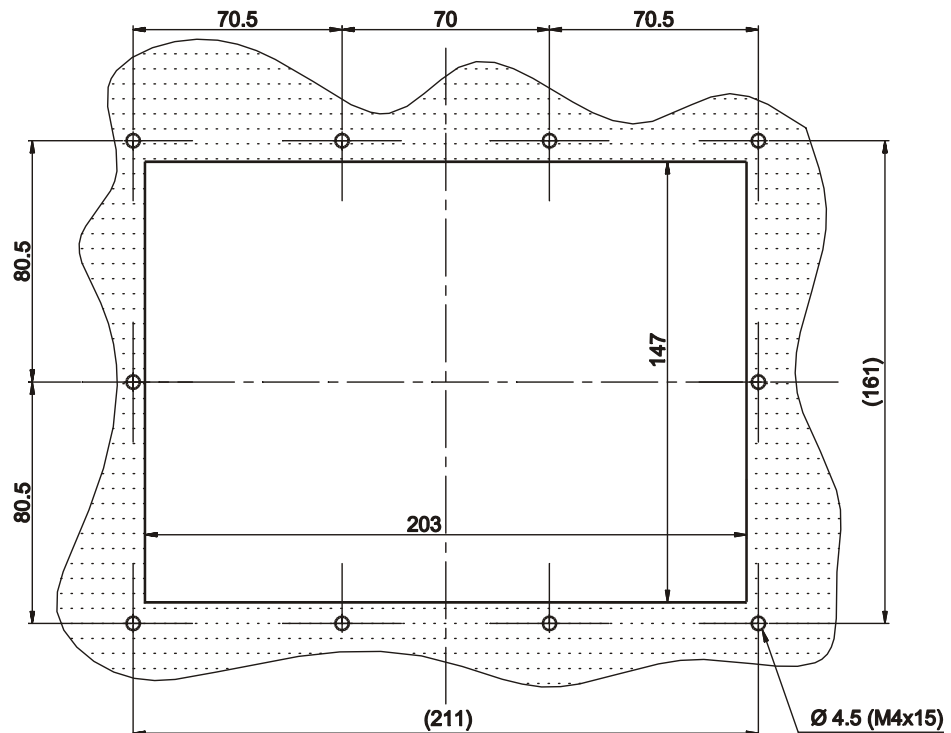

4.4 DIMENSIONS OF THE 10" DEVICES

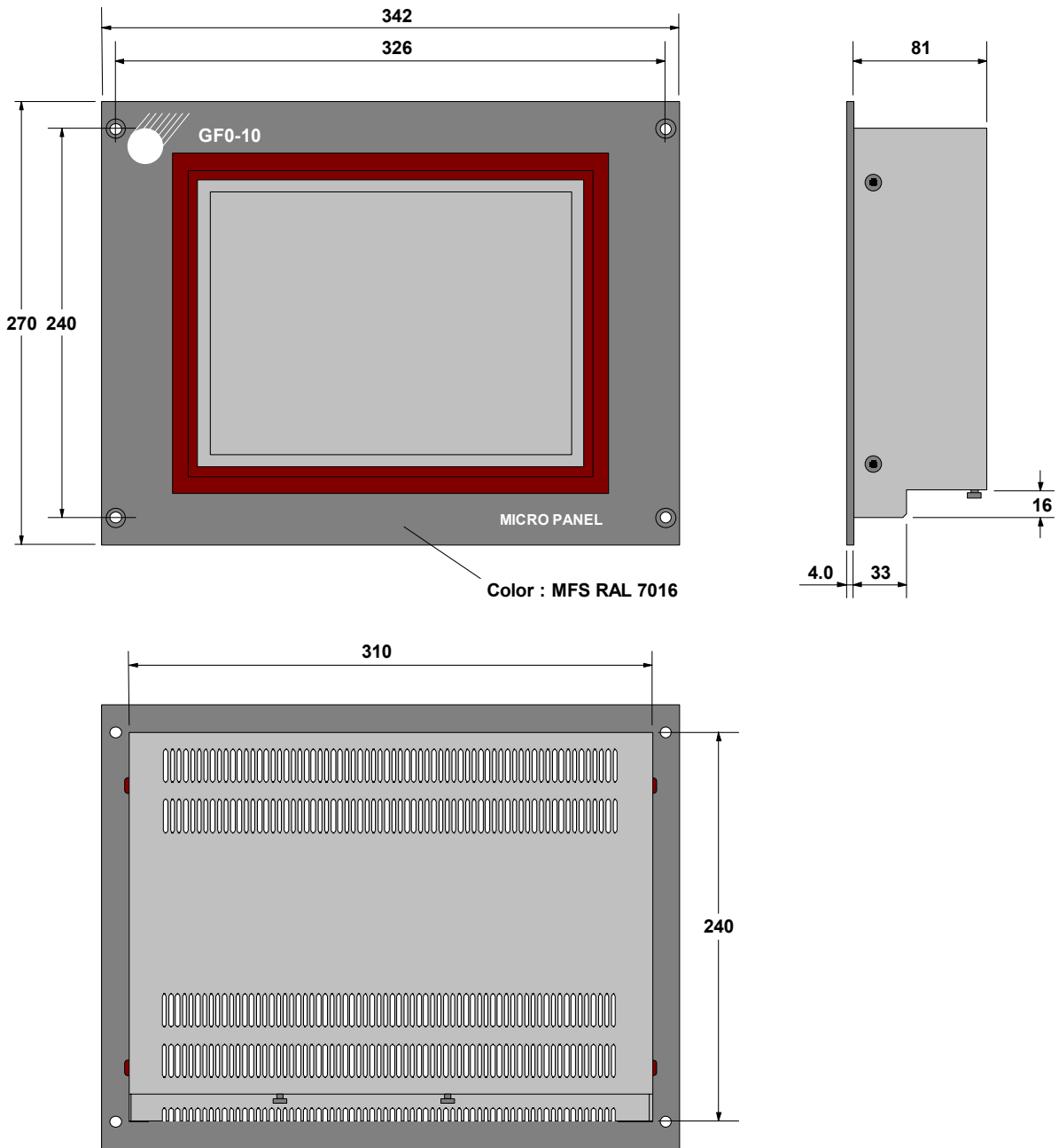

The figure above shows the dimensions of the GF0-10xxx-xx0 devices. These units are provided with a four-hole aluminium front.

The devices with threaded bolts (-xx1, -xx3) have identical outer dimensions. The fixing hole patterns of the Micro Panel GF0 vary according to the version concerned.

Refer to the following section for the front panel cutouts of specific versions.

4.5 FRONT PANEL CUTOUTS FOR 10" DEVICES

Cutout and hole pattern for device versions with 4-hole aluminium front (-xx0)

Front panel cutout: **316x244 mm** (centrally to fixing holes)

Fixing screws: **M5 countersunk screw**

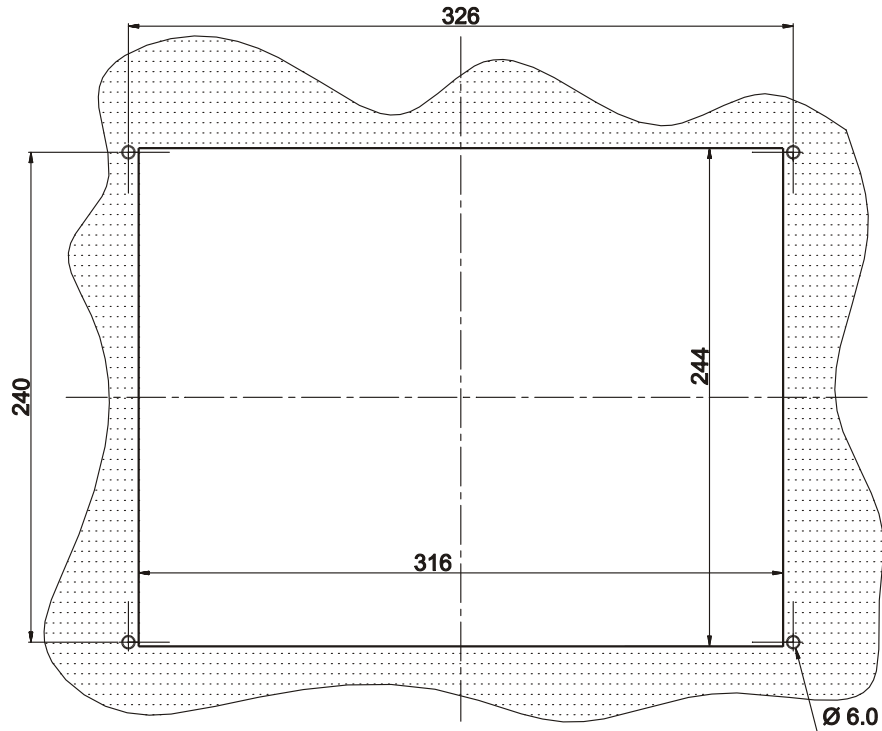

Cutout and hole pattern for device versions with front with threaded bolts (-xx1, -xx3)

Front panel cutout : **316x244 mm** (centrally to fixing holes)

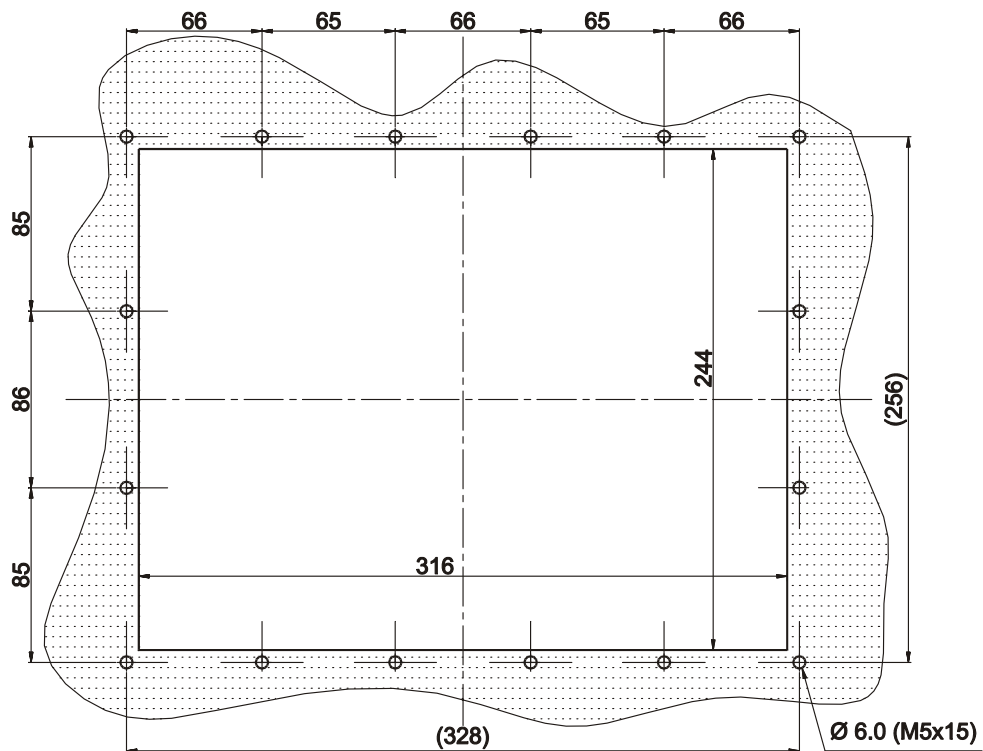

5 MOUNTING INSTRUCTIONS

5.1 MOUNTING (WITHOUT SPECIAL DEGREE OF PROTECTION)

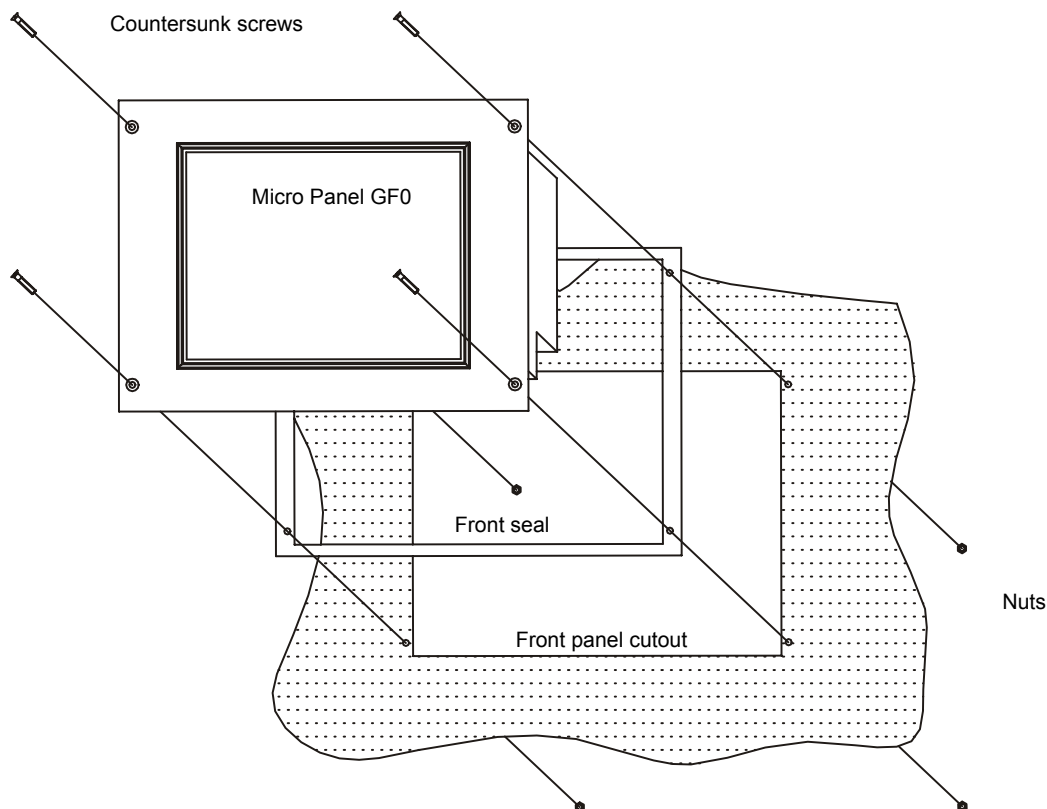

1. Fit the front seal from the rear of the device.
2. Insert the Micro Panel GF0 into the panel cutout from the front (without any force).
3. The front seal must fit evenly between the front plate and the front panel.
4. Screw the countersunk screws on the device through the front panel into the corresponding nuts. The countersunk screws must be tightened evenly and securely.

Observe the general mounting instructions (→ Section 4.1).

5.2 MOUNTING ACCORDING TO DEGREE OF PROTECTION IP 65

An additional mounting kit is available for mounting devices with 4-hole aluminium fronts in accordance with IP65 (→ Section 17). This consists of a conter frame that is fitted at the back of the front panel so that the required pressure on the seal is ensured even when fitting to a thin panel.

The conter frame must be ordered separately.

Conter frame for GF0-57xxx-xx0, MDS Order No. : 65 18 972060

Conter frame for GF0-10xxx-xx0, MDS Order No. : 65 20 963100

6 CONNECTING THE SYSTEM POWER SUPPLY

The Micro Panel GF0 is classified to protection class 3. The system power supply must be connected to an **SELV** (safety extra-low voltage) 24VDC supply (→ Section 17). The power supply is not isolated. The 0V terminal is located directly on the housing potential. The power supply must be fuse protected (2.5 A slow), (→ Section 17). This can be accessed without having to open the device. The device is protected against reverse polarity, and the operation of the device depends on correct polarity.

Observe the relevant regulations for the connection of the Micro Panel GF0.

Carry out the connection as follows:

- The cross-section of the supply cable must be between 0.75mm² and 2.5mm².
- A lead or wire can be used for the connection.
- The power supply must be provided with the correct current consumption (→ Section 17), selectivity and breaking capacity in accordance with the specified disconnection characteristics (→ Section 17).
- A functional ground is not compulsory for correct operation. The GND is connected directly to the housing potential.

The connector (socket strip with screw terminals) is supplied with the device.

Connector assignment:

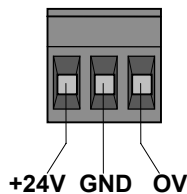

(Plug-in screw terminal, Phoenix: MSTB 2.5/3-ST-5.08)

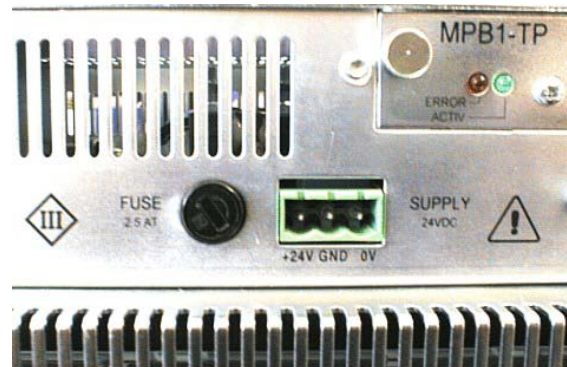

Section of the GF0-10 connector panel with a view of the system power supply plug connector and the fuse.

Designation	Function
+24V	+24V power supply
GND	Functional ground
0V	0V power supply

7 CONNECTION TO THE COMMUNICATION INTERFACE

7.1 PREPARING THE CONNECTION CABLE (EMC)

The preparation of the data and signal cables is an important factor for the electromagnetic compatibility (EMC) of the Micro Panel GF0, both in terms of interference immunity and emission.

All data cables on the Micro Panel GF0 (PROG PORT) and on the card in the slot (COM SLOT) must be **shielded** unless unshielded wiring is specified explicitly. Cables connected to the communications interface must be laid separately to low-voltage cables when they come together (cable ducts in separate partitions).

The cable shield must be made from copper braid. Only use a metal or metallised connector casing. Connect the cable shield directly to the low-impedance connector casing on the GF0. This ensures that the cable shield is properly connected to the housing of the Micro Panel GF0 via the screws and the protective metal shroud of the plug connector (low-impedance).

The cables must also be shielded if they are not connected at the other end and are only used, for example, for commissioning and servicing.

Refer to the operating instructions of the device manufacturers concerned as to how to connect the shield at the other end. If no specifications are given, connect the cable shield also at this end to the metal or metallised connector casing.

Avoid leaving the shield open. The data connections to be shielded involve the high-speed transfer of signals between two active systems. The cable shield only functions against asymmetrical interference transients if the shield is connected to the device earths (usually metallic device casing) at both ends.

Provide a potential equalisation conductor with a suitable cross-section between potentials (control cabinets) if the Micro Panel GF0 and the communications partner are installed in different control cabinets or at different PE potentials (zero conductor potentials), and if the cable shield at both ends is directly or indirectly connected to the protective earth conductor. This will prevent the occurrence of large compensation currents on the shield and shield connections. These kinds of compensation currents of normally 50 Hz even occur in normal operation and do not represent a problem for data transmission. However, they may cause the destruction of the shield terminals and contacts, particularly in the event of short-circuits in the environment.

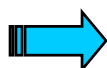

Special care should be taken with the connection to ensure interference-free operation.

The EMC values stated in the technical data can only be guaranteed if the cables are prepared according to the specifications.

7.2 PREPARING THE SHIELD CONNECTIONS

The connections on the Micro Panel GF0 and especially the communications card are mostly implemented with D-subminiature connectors in accordance with DIN 41652. Only use metal or metallised connector casings with a cable clamp for strain relief fastened or clamped on one side of the connector. The clamping of the cable shield ensures an optimum contact area and a low impedance connection with the connector casing of the Micro Panel GF0.

The following procedure is recommended for making the low-impedance connection for the cable shield:

1. Strip the cable.
2. Shorten the exposed shield braid by approx. 3 cm.
3. Turn back the braid over the cable sheath.
4. Use a heat shrinkable tubing or rubber grommet to cover the exposed cable sheath with the folded back shield braid so that 5 to 8 mm of exposed cable shield is left at the sheath end and is cleanly covered at the back.
5. Fit the connector.
6. The cable is then fastened at the exposed shield braid and the cable sheath below it directly underneath the cable clamp strap of the connector casing.

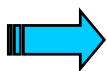
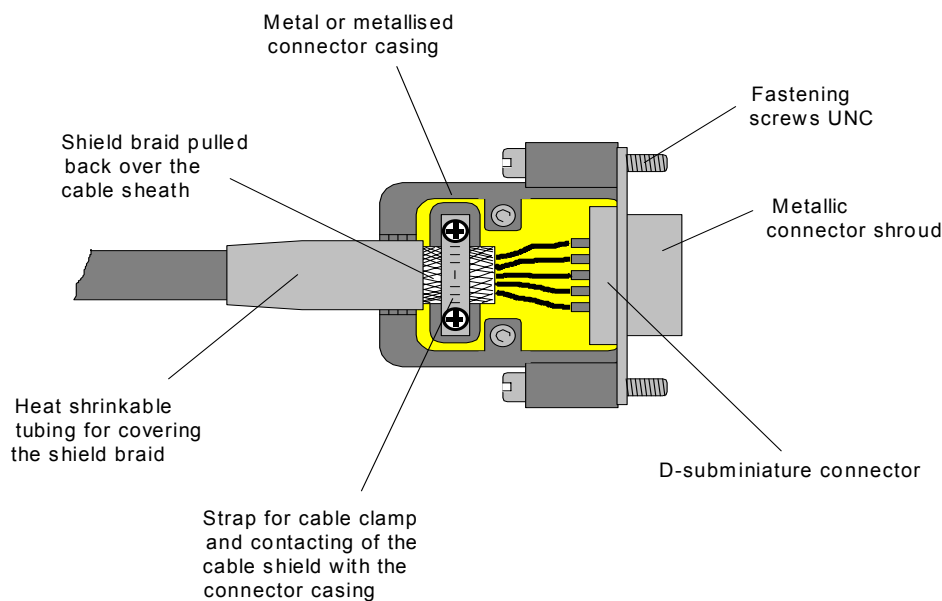

If plug connectors are used for communications cards (not D-subminiature plug connectors to DIN 41652), then follow the instructions in the relevant document descriptions.

8 CONNECTION AND FUNCTION OF THE PROGRAMMING PORT (PROG PORT)

The project data is loaded into the Micro Panel GF0 (Download) via the programming port (PROG PORT). The programming port can also be used to connect a serial printer for printing reports from the application.



Refer to the documentation of the GALILEO design software for information on the connection and operation of a printer (printer installation).

The programming port is a standard RS232 interface.

The GND terminal is located directly on the housing potential (→ Section 17). Cables connected to the PROG PORT must be laid separately to low-voltage cables.

Pin 9 can be provided with an optional +5V (→ Section 11).

PROG PORT		
D-Sub 9 Pole male		
Pin No.	Assignment	Function
1	-	Not assigned
2	RxD	Receive data
3	TxD	Send data
4	DTR	Data terminal ready
5	GND	Ground
6	DSR	Ready for operation
7	-	Not assigned
8	-	Not assigned
9	(+5V)	+5V power supply (→ Section 11)
Case	Shield	Cable shield

9 DATA TRANSFER TO THE MICRO PANEL GF0 (DOWNLOAD BUTTON)

The Micro Panel GF0 basic function is used to load the runtime program. This runtime program (GRSW) contains the function for loading project data, and so this program must be loaded before the loading of project data is at all possible.

Pressing the Download button calls up the functions for loading project data and/or the Runtime (Download) (→ Section 9.1 / 9.2).

The Download button is located on the rear of the Micro Panel GF0.

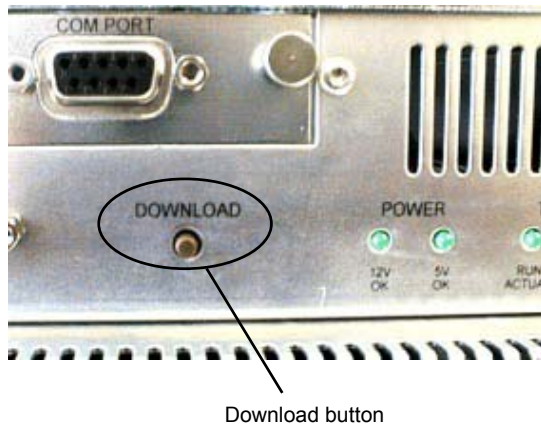

9.1 LOADING THE RUNTIME (GRSW)

The "APPLICATION LOADER" system mask will appear when the system is started. This application loader is a fixed part of the Micro Panel GF0 firmware (basic function). When the system is started the application loader searches for the runtime. This is indicated by the system message "Search program .". The message "ok" will appear when the runtime program is found.

The integrity of the runtime program is then checked, and is indicated by the system message "check GRSW.EXE" with date and time. If the runtime program is correct, the "ok" system message will appear and the runtime program is started.

```

MAINBOARD FIRMWARE VERSION 3.XX (WIN32)
  > APPLICATION LOADER <

- search program .. ok
- check GRSW.EXE
  XX/XX/XX XX:XX .. ok

```

Systemmask "APPLICATION LOADER" (Figure GF0-57xQD)

If the application loader does not find an integral runtime program, the Micro Panel GF0 switches to the "SERIAL DOWNLOAD" system mask. In this mode the Micro Panel GF0 will try to establish a connection to the PC via the programming port (PROG PORT). The runtime program can then be processed in conjunction with the design software (GALILEO).

This mode can also be accessed by pressing the Download button. For this, press the Download button while the Application Loader is searching for the runtime program, i.e. **whilst** "search program..." is showing in the "APPLICATION LOADER" system mask, and before the "ok" system message is shown.

The runtime program (a runtime program is already present on the Micro Panel GF0) can be updated with the design software at any time when loading project data (→ Section 9.2).

```

MAINBOARD FIRMWARE VERSION 3.XX (WIN32)
  > SERIAL DOWNLOAD <

- waiting for host ..

```

System mask for loading the runtime (GRSW) (Figure GF0-57xQD)

9.2 LOADING THE PROJECT DATA (DOWNLOAD)

Pressing the Download button whilst the application is running accesses the system function for loading project data and for **reloading** the runtime program. A short press of the Download button switches the Micro Panel GF0 to the "Serial Data Transfer PC<>Panel" system mask.

In this Download mode the Micro Panel GF0 tries to establish a connection to the PC via the programming port (PROG PORT). The design software (GALILEO) can then be used to load project data and/or to reload the runtime program.

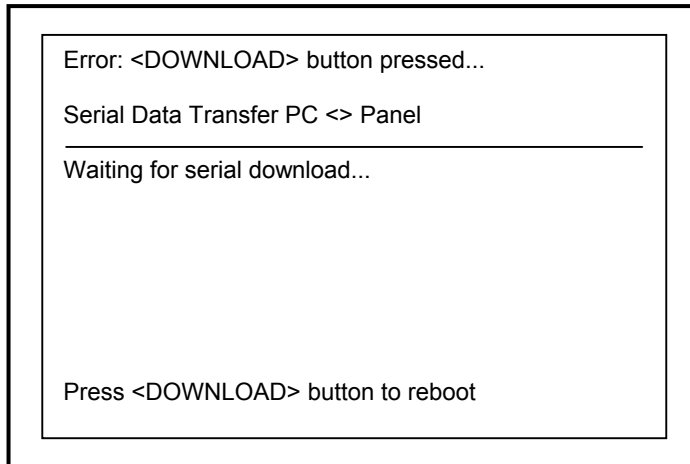

System mask for serial data transfer (Figure GF0-57xQD)

The system also switches to this Download mode if the runtime program does not find an executable project or in the event of a fatal error. The system indicates the reason for the change to Download mode in the first line of the screen.

To quit Download mode press the Download button or briefly interrupt the power supply.

10 COMMUNICATIONS CARDS AND COM SLOT

The Micro Panel GF0 has one slot for a communications card (→ Section 17). The link to the automation equipment (e.g. PLC) or the fieldbus system is implemented using one of the several cards available.

Please contact your local Micro Panel dealer or the Technical Support at Micro Innovation AG for information concerning currently available communications cards and communication protocols.



Safety precautions concerning electrostatic discharge (ESD) must be observed when handling cards !



**Never plug in the cards with the power supply switched on.
Only operate the communications card once it has been fully screwed into position.
Do not run any non-Micro Innovation components in the slots. Only original hardware from Micro Innovation AG may be used.**

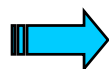

Refer to the relevant communication card descriptions for information on protocols, configuration, cable lengths etc.

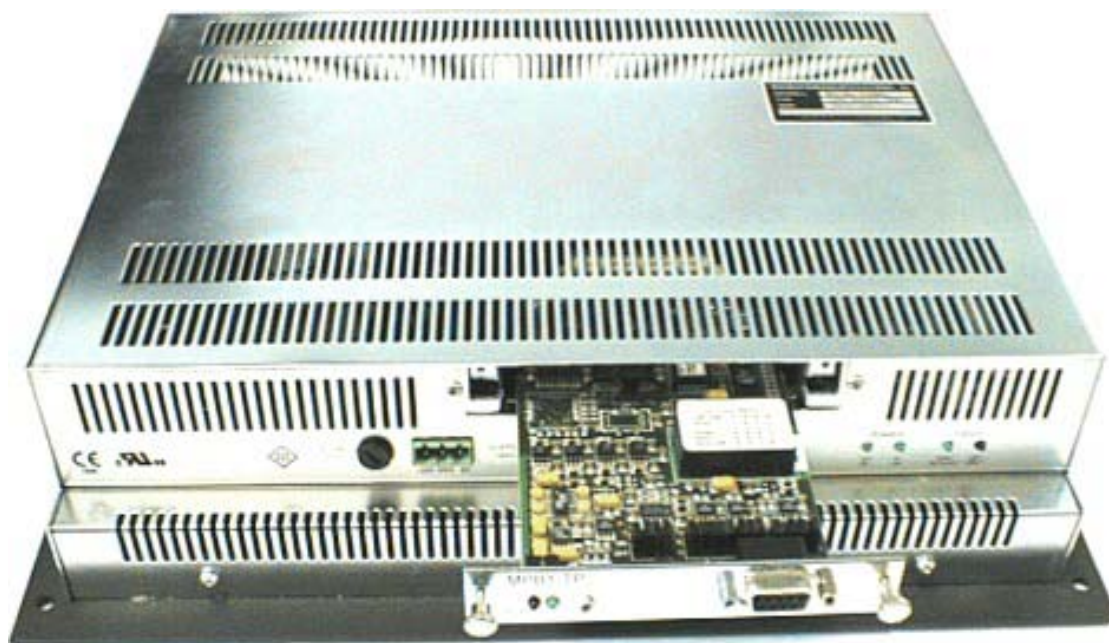

Communications card in COM SLOT of the Micro Panel GF0

11 EXPANSION AND CONFIGURATION OPTIONS

11.1 GENERAL REQUIREMENTS

The expansion options described in Section 11 require interventions inside the Micro Panel GF0. These modifications and expansions must only be carried out with the power supply disconnected, i.e. with the panel in a de-energised state.



Interventions in the device must only be carried out with the power supply disconnected ! During operation some live parts carry dangerous voltages !



Safety precautions concerning electrostatic discharge (ESD) must be taken when making interventions in the device.

11.2 MEMORY EXPANSION

The Micro Panel GF0 is provided as standard with a fixed memory of 4MByte. A memory expansion socket is also provided for the device concerned (→ Section 17). Only one memory expansion with the appropriate memory size can be fitted (not cascable).

To fit the memory expansion remove the communications card from the COM SLOT and unscrew the device. As shown in the figure below, the memory expansion is fitted directly on the main board and fastened with screws. The memory expansion is coded by the connector used, thus preventing incorrect fitting. A change in memory capacity is automatically detected by the system.

The two screws required (M2.5 x 5) are supplied with the memory expansion.

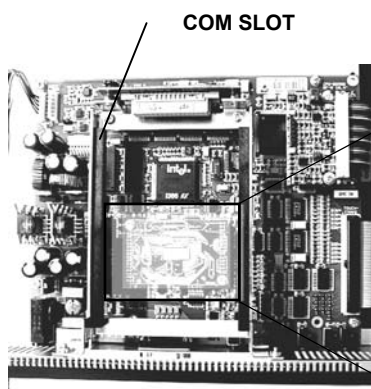

View into the opened Micro Panel GF0-10. The memory expansion is located underneath the COM SLOT.

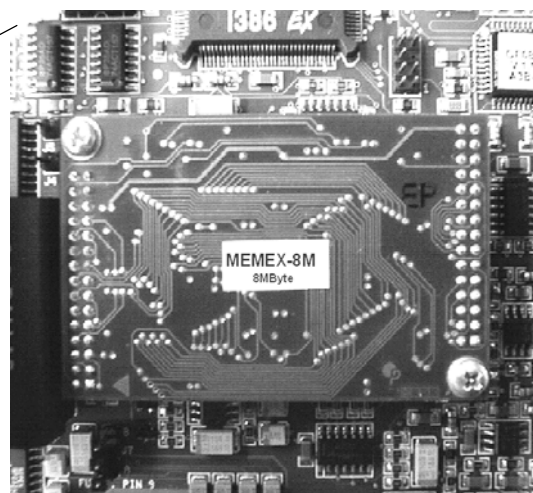

Fitted memory expansion (8 MByte)

Available Memory Expansions	Type Designation
Memory Expansion 4M Byte	MEMEX-4M
Memory Expansion 8M Byte	MEMEX-8M

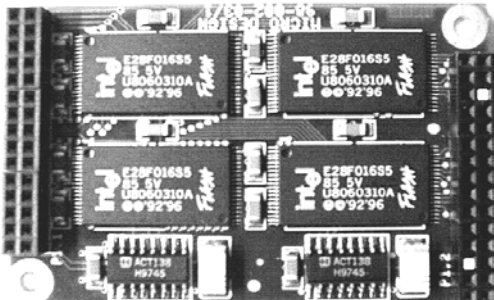

Memory expansion with a view of the connector.
Scale approx. 1:1

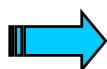

Only operate the memory expansion when it is fastened with the screws specified!
Do not use any non-Micro Innovation components for memory expansion.
Only original hardware from Micro Innovation AG may be used.

11.3 ADDITIONAL 5V POWER SUPPLY ON PROGRAMMING PORT (PROG PORT)

Pin 9 of the **PROG PORT** can also be used for the power supply (+5V) of external additional hardware (jumper J7 on the main board set to position A). This is not short-circuit proof and not overload protected and must only be used in conjunction with original Micro Panel hardware. The power supply cannot be used for non-Micro Panel products.

12 FUNCTION AND CONTROL LEDs

The Micro Panel GF0 provides two LEDs for monitoring the functions of the touch controller (**TOUCH**) and two other LEDs for monitoring the system voltages (**POWER**). They are located underneath the COM SLOT.

Description of the LED:

TOUCH

DEF / DIRTY

The LED (red) is lit if during the power up function test of the Touch Screen the signal level of one or several IR channels is below the minimum level (→ Section 13.2). A reduction of the signal level is caused by the contamination of the IR transparent plastic frame or the failure of an optical element.

If this LED is lit, clean the plastic frame on the device front (→ Section 13.3).

RUN / ACTUATE

The LED (green) remains unlit when the system voltage is switched on. It will light up once the initialisation of the touch controller has been successfully completed.

The LED will be deactivated for approx. 0.3s when the touch screen is pressed.

POWER

12V OK

When lit the LEDs indicate the presence of the system voltages (+12V and +5V).

5V OK

If the LEDs are not lit when the system voltage is applied, check the fuse.

When the system voltage is switched on, both Touch LEDs are activated for approx. 0.3 as a function check.

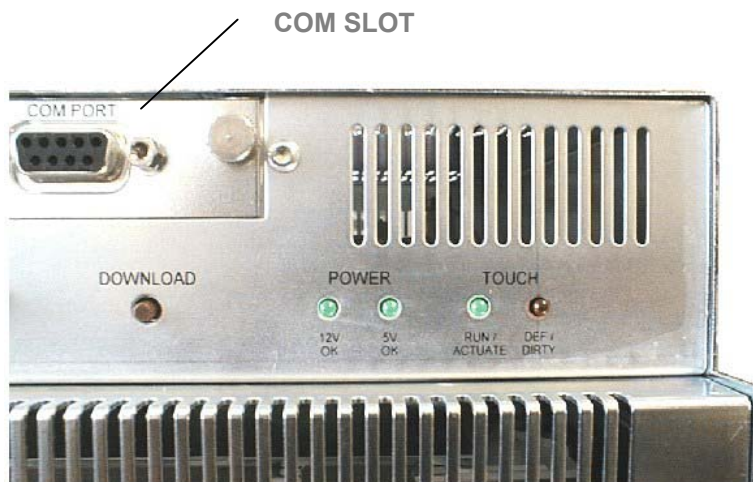

Section of the Micro Panel GF0 connector panel with a view of the control LED, the Download button and the COM SLOT.

13 TOUCH SCREEN

13.1 PRINZIPIELLE FUNKTION DES TOUCH-SCREEN

The Touch Screen operates on the active light matrix principle in the infrared range. The optical elements of the light matrix are located behind the IR transparent plastic frame in the front panel of the device. They are located in such a way that their radiation extends slightly out of the front pane. Each emitter is assigned a receiver that is located on the other side. In this way 40 closely positioned IR channels are provided on the 5.7" unit and 70 IR channels on the 10.4" unit (→ Section 17). A touch on the screen is detected by the simultaneous interruption of one or several channels in the X or Y axis.

Repeated touches and touches that cover an area greater than 20 mm x 20 mm are not evaluated by the controller. Continuously interrupted channels caused by severe contamination and dirt, or by the failure of an optical element are detected by the touch controller and are no longer included in the evaluation.

13.2 POWER UP FUNCTION TEST

The GF0 carries out a function test of the touch screen with each power up of the device. This test measures the signal levels of all IR channels and compares them with initial values. The initial values are determined before the device is delivered and stored in a retentive memory.

If the signal of one or several channels is below a minimum level relative to the initial values, this will be indicated by an error message on the screen and the **DEF/DIRTY** LED (→ Section 12). A reduced signal level of this kind is normally due to severe contamination of the IR transparent plastic frame which consequently has to be cleaned (→ Section 13.3). The Touch Screen, however, remains fully functional.

Only an increase in the contamination of the screen will lead to the continuous interruption of one or several IR channels. IR channels that are continuously interrupted will be detected by the Touch Controller and no longer included in the evaluation. In extreme cases, this may mean that individual zones cannot be activated by touch.

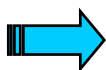

Do not touch the screen whilst the system is being started up, and wait till your application has started.

During the startup the Touch Screen carries out a function test in which the signal levels of the IR channels are measured.

13.3 CLEANING AND MAINTENANCE OF THE TOUCH SCREEN

For operation ensure that the signal levels of the channels are not so severely reduced or interrupted due to excessive contamination through dirt (→ Section 13.1).

Clean the inside of the plastic frame of the device regularly (→ Section 15) with a damp soft cloth. Ensure that the surface is not scratched or scoured, especially when removing hard deposits and abrasive dust.

Do not expose the front of the device to solvents which may corrode and destroy the plastic frame (frame material: polymethylmethacrylate, PMMA).

14 DISPLAY

The different versions of the Micro Panel GF0 are available with different display technologies. Passive LCD, monochrome or color screens are available as well as monochrome electroluminescent (EL) displays.

EL displays generate the image by means of active electroluminescent yellow pixels, thus making a backlight unnecessary.

The individual pixels of an LCD display are not actively illuminated. The image is produced by illuminating the screen by a backlight which is varied in colour and intensity by means of the individual LCD cells (pixels).

The light of this backlight is provided by a cold cathod tube. The lifespan of these tubes (→ Section 17) is limited and depends on the operating conditions at hand. The brightness setting of the backlight and the number of switch-on cycles will determine the lifespan of the screen. Reducing the brightness can significantly increase the lifespan of the LCD display. Frequent switching, especially at low temperatures will reduce the lifespan.

Therefore avoid frequent switching on and off of the backlight or the entire system. Reducing the brightness to a minimum setting is better than frequently switching the display on and off.

Particularly with LCD displays the image contrast depends on the viewing angle. The operating temperature also has a direct influence on the contrast and consequently also on the viewing angle. Any detrimental influences caused by temperature are reduced by an additional circuit in the device (partial compensation). The contrast (contrast voltage) may need to be adjusted due to the viewing angle requirements of different people or changes in the ambient temperature. This can be carried out on the Touch Panel by the operator.

Further information on adjusting the brightness of the backlight and the contrast is provided in the documentation of the GALILEO design software.

15 MAINTENANCE AND REPAIR

The Micro Panel is maintenance-free.

The inside of the device front panel should be cleaned regularly to ensure trouble-free IR touch screen operation (→Section 13.3).

Repairs to the Micro Panel GF0 must only be carried out by the manufacturer or Micro Innovation repair centres. Contact in this case your local Micro Panel dealer or the Technical Support at Micro Innovation AG.

Modifications made to the device that are not described in this document are not permitted and no liability will be accepted for them (manufacturer address for Micro Panel GF0, see Section 19).

16 DISPOSAL

Micro Panel devices that are no longer used must be disposed of properly or returned to the manufacturer for disposal (manufacturer address for Micro Panel GF0, see last page).

Special note:

- The clock module contains a sealed lithium battery. (Real Time Clock, Dallas DS12887 or STMicroelectronics M48T86PC1)
- The backlights for units with LCD displays are provided by fluorescent tubes that contain mercury.

Device description GF0

MICRO PANEL

Technical data

17 TECHNICAL DATA

Display	Technology	GF0-xxCxD	Passiv color LCD (color STN-LCD)
		GF0-xxSxD	Passiv monochrom LCD (mono STN-LCD)
		GF0-57EQD	Elektrolumineszenz Display (EL-Display mono)
	Resolution	GF0-57xQD	320 x 240 Pixel
		GF0-10xVD	640 x 480 Pixel
	Display area	GF0-57xQD	115 mm x 86 mm
		GF0-10xVD	212 mm x 158 mm
	Number colours / greyscales	GF0-xxCxD	256
		GF0-xxSxD	256
		GF0-57EQD	3
Contrast ratio (normally)	GF0-57CQD	25	
	GF0-57SQD	24	
	GF0-57EQD	50	
	GF0-10CVD	30	
	GF0-10SVD	18	
Brightness (normally)	GF0-57CQD	110 cd/m ²	
	GF0-57SQD	140 cd/m ²	
	GF0-57EQD	50 cd/m ²	
	GF0-10CVD	70 cd/m ²	
	GF0-10SVD	75 cd/m ²	
Lifespan of backlight (only LCD / without backlight saver)	GF0-57CQD	25'000 POH	
	GF0-57SQD	20'000 POH	
	GF0-10xVD	25'000 POH	
Operation	MDS TCL2		
	Optical light matrix in the infrared range (IR Touch → Section 13)		
	Resolution physical	GF0-57xQD	24 x 16 (13 x 15 Pixel)
		GF0-10xVD	40 x 30 (16 x 16 Pixel)
Resolution logic	GF0-57xQD	47 x 31 (7 x 8 Pixel)	
	GF0-10xVD	79 x 59 (8 x 8 Pixel)	
System memory	Technology	Flash	
	Basic unit	4 MByte (permanently soldered)	
	Memory expansion	max. 20 MByte (→ Section 11)	
Prog Port	RS 232, non-isolated and not earth-free	(→ Section 8)	
Ambient conditions	Operating climate	0...50°C, 10...85% rel. air humidity, non-condensing (→ Section 4)	
	Storage climate	-20...60°C, 10...85% rel. air humidity, non-condensing	
	Mech. shock	IEC 68-2-27 (1 shock, half-sinus 50g/20ms)	
	Vibration	IEC 68-2-6 (10...200...10Hz/1.5g)	
	EMC	IEC 1000-4-2, EN 61000-4-2, 6 kV / 8 kV IEC 1000-4-3, EN 50140, 10 V/m IEC 1000-4-4, EN 61000-4-4, 2 kV EN 61000-4-6, ENV 50141, 10 VEMF IEC 1000-4-8, EN 61000-4-8, 10 A/m	
	Radio interference	CISPR 11, EN 55011, Class A	

MICRO PANEL

Device description GF0

Technical data

Protection type	Front	IP 65), to EN 60529 Degree of protection IP65 only with additional mounting kit ! (→ Section 5.2)
	Rear	IP 20
Front pane	GF0-57xQD	Glas 2.0 mm, non-reflective (etched)
	GF0-10xVD	Glas 3.0 mm, non-reflective (coated) (optional Kunststoff, entspiegelt)
Weight	GF0-57xQD	ca. 2.2 kg
	GF0-10xVD	ca. 3.6 kg
Dimensions	Front	GF0-57xQD 220 x 170 mm
		GF0-10xVD 342 x 270 mm
	Rear	GF0-57xQD 201 x 144 x 83 mm
		GF0-10xVD 310 x 240 x 81 mm
System supply	Rated voltage	SELV 24 VDC, Safety extra-low voltage (→ Section 6)
	Voltage range	24 VDC to DIN 19240 20.4...28.8 VDC effective, absolute value with ripple 18.5...30.2 VDC 35.0 VDC for < 100ms
	Voltage dips	5 ms max., at 20.4 VDC to 0 VDC, repetition rate 1 s
	Reverse polarity protection	Yes
	Isolation	No, 0V and PE connection to housing potential
	Power consumption (incl. comms. card and mem. exp.)	GF0-57xQD 0.7 A (typ.) GF0-10xVD 0.7 A (typ.)
	Einschaltstrom maximal	1.5 A ² s
	Current consumption (incl. comms. card and mem. exp.)	GF0-57xQD ca. 20 W GF0-10xVD ca. 20 W
Fuse protection	Internal	2.5 A slow, accessible from outside (→ Section. 6)
	Maximum disconnection capacity	35A (→ Section. 6)
Interfaces		1 slot for communications card (→ Section. 10)

18 EC CONFORMITY

The **Micro Panel GF0** meets the requirements specified by the EC Council Directives for harmonizing the regulations of EC member states relating to electromagnetic compatibility (**89/336/EEC**) and electrical safety (Low-Voltage Directive **73/23/EEC**).

The generic standards below were used to assess the electromagnetic compatibility of the Micro Panel GF0:

EN 50081-2 (Emission)

EN 50082-2 (Immunity)

The following standard was used to assess the electrical safety of the Micro Panel GF0:

EN 60950



Manufacturer: Micro Innovation AG

Manufacturer address: Spinnereistrasse 8-14
9008 St. Gallen
Switzerland

19 UL-LISTING

The Micro Panel GF0 is listed by Underwriters Laboratories Incorporation (UL). File E208621.

Representative samples of the Micro Panel GF0 have been evaluated by Underwriters Laboratories Incorporation and meet the applicable United States and Canadian safety standards.

To assess the safety of the Micro Panel GF0 the safety standard UL 1950 (Safety of Information Technology Equipment, Including Electrical Business Equipment) was used.



20 REVISION HISTORY

Index	Date / Visum	Alteration
01	12.11.03/ RA	Included in DokV

**Micro Innovation AG
Spinnereistr 8-14
CH-9008 St. Gallen
Switzerland**

**Tel : ++41- 71 243 24 24
Fax : ++41- 71 243 24 90
email : info@microinnovation.com
homepage : <http://www.microinnovation.com>**