



Operation Manual

SV-DB100 AC servo drives



Preface

Thanks for using AC servo drive of the permanent magnet synchronous motor (hereinafter called "servo drive") from Shenzhen INVT Electric Co., Ltd. Please carefully read and master the user's manual before proper use. Improper use may cause abnormal running or shorten its service life or even directly damage the drive.

Please keep this manual carefully for later reference.

Safety precautions

The precautions related to safe operation are classified into “Warnings” and “Notes”.



Warning

Point out potential danger which, if not avoided, may cause physical injury or death.



Note

Point out potential danger which, if not avoided, may result in mild or moderate physical injury and damage to the equipment. It's also available to warn about unsafe operations.

In some cases, even the content described in “Note” may also cause serious accidents. So please follow these important precautions in any situations.

Warning signs are presented on the sides of the servo drive. Please follow these instructions when using the servo drive.

Warning signs:

Danger

Read the manual and follow the safety instructions before use.

Touch current may be over 3.5mA, Must be grounded before operation.



High Voltage

Do not touch terminals within 15 minutes after disconnecting the power. Risk of electric shock.



High Temperature

Do not touch heat sink when power is ON. Risk of burn.

Please pay attention to the following safety precautions during installation, wiring, operation, maintenance and inspection.

Installation:

Warning

Please use the servo drive and servo motor with the instructed combination mode. Otherwise it may cause malfunction or even fire of the equipment.

Never expose the product to an environment containing moisture, corrosive gas, or flammable gas. Otherwise it may cause electrical shock or fire.

Wiring:

Only qualified electricians are allowed to carry out the wiring. Otherwise there is danger of electrical shock or fire.

The grounding terminals of the drive and motor must be grounded with proper techniques. Otherwise there is danger of electrical shock.



Do not touch the conductive components directly. Do not connect the output lines of the drive with the enclosure. Avoid short circuit of the output lines. Otherwise there is the danger of electrical shock or short-circuit.

Ensure the installation of available overcurrent protector, leakage protector and E-stop devices after distribution. Otherwise there may be danger of electrical shock, injury and fire.

Redistribute the drive in at least 15 minutes after disconnecting the power supply.

Make sure the voltage of the AC power supply equals to the rated voltage of the servo drive. Otherwise there is danger of injury, fire and damage to the drive.



Never connect the input power lines to the output terminals as this will damage the drive.

Never conduct voltage withstand test on the drive or its connection wires as this will cause damage to the drive.

Connect the drive and motor with correct phase sequence. Otherwise it may cause malfunction or damage the drive.

Operation:

Please de-coupled the load from the drive before the trial operation for the avoidance of accidents.



Check that the supply power of the drive can be disconnected with the E-stop switch all the time before running.

Verify and adjust all parameters before running. Otherwise the drive may run abnormally or act unexpectedly due to the load.

Do not touch the radiator or the external braking resistor during running. They may become very hot and burn fingers.

Maintenance and inspection:

Warning

Before doing any inspection and maintenance, be sure to disconnect the power supply, wait for 15 minutes and then confirm with a multimeter. Otherwise electric shock may occur. Only qualified electricians are allowed to inspect the servo drive. Otherwise electric shock may occur.

Content

Preface	I
Safety precautions	II
Content	1
1 General	1
1.1 General technical specifications.....	1
1.2 Nameplate of the servo drive.....	4
1.3 Illustration of the nameplate.....	4
1.4 Power specification.....	5
1.5 Illustrations of every parts of the servo drive.....	6
1.6 External dimensions and installations sizes of the servo drive.....	6
2 Unpacking inspection	8
3 Installation	9
3.1 Environmental Requirement.....	9
3.1.1 Temperature.....	9
3.1.2 Relative humidity.....	9
3.1.3 Altitude.....	9
3.1.4 Other environment requirements.....	10
3.2 Installation of the servo drive.....	10
3.2.1 Installation.....	10
3.2.2 Installation direction and spacing.....	11
3.2.3 Avoid intrusion of foreign objects.....	12
4 Signal and wiring	13
4.1 System configuration.....	14
4.1.1 Connection diagram of the servo drive and external equipment.....	14
4.1.2 Cable diameter selection.....	14
4.1.3 EMI filter selection.....	15
4.1.4 Braking resistor selection.....	16
4.2 Wiring of the main circuit (Plug X1 and X2).....	17
4.2.1 Overview.....	17
4.2.2 Wiring diagram of single phase 230V power input.....	18
4.2.3 Wiring diagram of three-phase 230V power input.....	19
4.2.4 Wiring diagram of three-phase 400V power input.....	20
4.3 Wiring of the encoder (plug CN2).....	21
4.3.1 Overview.....	21
4.3.2 CN2 pin arrangement and signal definition of the servo drive.....	21
4.4 Connection with the PC or HOST (CN3 plug).....	22
4.5 I/O signal wiring (CN1 connector).....	23

4.5.1 Overview	23
4.5.2 CN1 pin arrangement and signal explanation	24
4.5.3 Standard wiring of the position control mode	34
4.5.4 Standard wiring of the speed control mode	35
4.5.5 Standard wiring of the torque control mode	36
4.5.6 Detailed instruction of the input and output of CN1	37
4.6 Wiring of the electromagnetic brake.....	43
5 Running and operation	44
5.1 Running	44
5.1.1 First powering on.....	44
5.1.2 Self-test before running of the servo	45
5.1.3 Parameter setting before running the servo.....	45
5.1.3 Trial jogging	46
5.1.4 Running at the position control mode.....	46
5.1.5 Running at the speed control mode.....	47
5.1.6 Running at the torque control mode	48
5.1.7 Parameter setting before running the servo.....	49
5.1.8 Servo enabling	50
5.1.9 Coast to Stop / DEC to Stop of the servo	50
5.1.10 Sequence diagram	52
5.2 Display and operation	57
5.2.1 Display	57
5.2.2 State monitoring mode	58
5.2.3 Parameter setting	60
5.2.4 Auxiliary functions.....	66
5.2.5 Alarm display	67
5.2.6 Alarm clearance.....	68
6 Detailed parameter description.....	69
6.1 Basic parameters (FP0 group parameters).....	69
6.1.1 Basic control	69
6.1.2 Position control.....	76
6.1.3 Speed and torque control.....	79
6.2 Self-turning control parameters (FP1 group parameters).....	88
6.2.1 Inertia identification(Automatic gain)	88
6.2.2 Adaptive vibration control.....	90
6.3 Motor control parameters (FP2 group parameters)	92
6.3.1 Gain	92
6.3.2 Gain switching	94

6.3.3 Special motor control.....	96
6.4 I/O management parameters (FP3 group parameters)	96
6.4.1 Digital input	96
6.4.2 Analog input / output adjustment	97
6.4.3 Switch input / output settings	100
6.5 Extension and application (FP4 group parameters)	103
6.5.1 Communication setting	103
6.5.2 Alarm threshold setting	106
6.6 Factory parameters (FP9 group parameters)	107
6.7 State monitoring	108
7 Gain adjustment.....	114
7.1 General method for adjusting parameters	114
7.1.1 Adjustment of the gain of the position loop	116
7.1.2 Adjustment of the gain of the speed loop	117
7.1.3 Adjustment of the gain of the torque loop	119
7.2 Suppression of mechanical resonance	120
7.3 Gain switching function	121
8 Communication function	122
8.1 General.....	122
8.2 Topological structure	122
8.2.1 Communication with single set	122
8.2.2 Communication with multiple sets	122
8.3 Communication protocol	123
8.3.1 Protocol Content.....	123
8.3.2 Protocol instructions	123
8.3.3 Communication Protocol Format	124
8.3.4 Command code and the communication data instructions	125
8.3.5 Error checkout of the communication frame	131
8.3.6 Address definition of communication data.....	132
8.3.7 Fault Responses	134
9 Fault processing	136
9.1 Meanings of the fault alarm codes and countermeasures.....	136
9.2 Meanings of the warning codes	139
Appendix A List of function parameters	140
Appendix B Signal arrangement diagram	147
B.1 CN1 pin signal arrangement:	147
B.2 CN2 pin signal arrangement:	147
B.3 CN3 pin signal arrangement:	148

Appendix C Plug signal of servo motor	149
C.1 Plug of the motor	149
C.1.1 Below and including 750:	149
C.1.2 Above 750W.....	149
C.2 Plug of encoder wire.....	149
C.2.1 Below and including 750W	149
C.2.2 Above 750W.....	150
Appendix D Wiring examples	152
D.1 Connection with Panasonic FPG-C32T	152
D.2 Connection with Panasonic FP2-PP22 (AFP2434).....	153
D.3 Connection with Panasonic FP2-PP2 (AFP2430).....	154
D.4 Connection with Yokogawa PLC F3YP14-ON/F3YP18-ON	155
D.5 Connection with Yokogawa PLC F3NC32-ON/F3NC34-ON.....	156
D.6 Connection with Omron CS1W-NC133/233/433.....	157
D.7 Connection with Omron CJ1W-NC133/233/433	158
D.8 Connection with Mitsubishi QD75D1	159
D.9 Connection with Mitsubishi FX-1PG	160
D.10 Connection with Mitsubishi FX2N-1PG	161

1 General

1.1 General technical specifications

The standard specifications of the AC permanent magnet synchronous servo drive are listed in the table below:

Table 1-1 Standard specifications of servo drive

Servo drive		Specifications		
		200W~400W	0.75kW~2.0kW	3.0kW~5.5kW
Power supply for the main circuit	Voltage degree	Single/3-phase 230V/50Hz	Single/3-phase 230V/50Hz	3-phase 400V/50Hz
	Input voltage range	AC 230V±15%		AC 400V±15%
	Input frequency range	47Hz~63Hz		47Hz~63Hz
Power supply for the control circuit	Voltage degree	Single phase 230V/50Hz		Single phase 400V/50Hz
	Input voltage range	AC 230V±15%		AC 400V±15%
	Input frequency range	47Hz~63Hz		47Hz~63Hz
Power supply for interfaces	Voltage	DC 12V~24V		
	Allowable voltage fluctuation	±10%		
	Power capacity	Above 500mA (the local 24V can only provide 100mA current)		
Control method		Vector control, SVPWM		
Control mode		Position control mode, speed control mode and torque control mode		
Dynamic brake		Yes		

Servo drive		Specifications		
		200W~400W	0.75kW~2.0kW	3.0kW~5.5kW
Regenerative braking unit		Built-in braking resistor, as well as the external braking resistor can be connected		
AC reactor		None		
Switch signal	Input	13 ways of optical coupling isolation input		
	Output	7 ways of open-collector output		
Analog	Input	2 ways, range: DC -10V~+10V		
	Output	2 ways, range: DC 0V~+10V		
Pulse	Input	2 ways, differential input or open-collector input		
	Output	4 ways, 3 ways of encoder A/B/Z phase frequency division differential output, 1 way of Z phase open-collector output		
Protection functions		Protection from overcurrent, overvoltage, overload, overheating, encoder fault, regeneration fault, undervoltage, overspeed and high tracking error and so on		
Position control	Input pulse frequency	500kHz (differential input) 200kHz (open-collector input)		
	Positioning feedback pulse	A/B orthogonal pulse Resolution: 10000 pulses/rev		
	Pulse amplification range	Electronic gear A/B: A=1~65535 and B=1~65535 $1/50 < A/B < 500$		
	Positioning accuracy	± 1 pulse		
	Setting the range for reaching the designated position	± 10 pulses		
	Range of fault	set within the range of ± 5 revs		
	Torque control range	Set via the parameter or external analog input of DC 0~ ± 10 V		

Servo drive		Specifications		
		200W~400W	0.75kW~2.0kW	3.0kW~5.5kW
		Max torque: 300% of rated torque		
Speed control	Frequency response	1000Hz		
	Speed control range	The Max speed is 5000r/min, the Min speed is 0.1r/min, and the speed regulation range is 1:50000		
	Analog speed command input	DC 0~±10V/Max rotation speed		
	Speed fluctuation rate	±0.03%		
	Torque control range	Set via the parameter or external analog input of DC 0~±10V Max torque: 300% of rated torque		
Torque control	Analog torque command input	DC 0~±10V/Max torque		
	Torque linearity	Below ±10%		
	Speed control range	Set via the parameter or external analog input of DC 0~±10V (Max rotation speed)		
Allowable Max inertia		30 times		
Communication	RS232	Host 1: 1 communication		
	RS485	Host 1: n communication, n≤32		
Structure		Natural cooling: IP20	Air cooling: IP20	
Environment	Operating temperature	0~45℃		
	Storage temperature	-20~80℃ (without freezing)		
	Humidity	Operating/storage: ≤90%RH (non-condensation)		
	Other	Indoor (without direct sunshine), free from		

Servo drive		Specifications		
		200W~400W	0.75kW~2.0kW	3.0kW~5.5kW
	environmental conditions	corrosive, flammable gasses, oil mist, dust		
	Allowable operating altitude	Should be derated if the altitude is higher than 1000m		
	Vibration	≤5.88m/s ² , 10~60Hz (not allowed to run at the resonant point)		

1.2 Nameplate of the servo drive

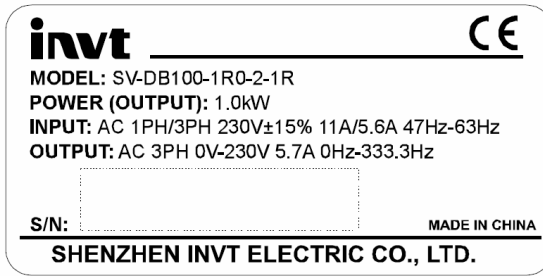

Fig. 1-1 Nameplate of the servo drive

1.3 Illustration of the nameplate

SV-DB100 -XXX -X-1 R□

A B C D E F G

Fig. 1-2 Meanings of the model

Field	Meaning
A	SV: (INVT) Servo system products
B	DB100: 1 st generation of simple products
C	Power degree:
	0R2: 200W 0R4: 400W 0R7: 750W 1R0: 1.0kW 1R5: 1.5kW 2R0: 2.0kW 3R0: 3.0kW 4R4: 4.4kW 5R5: 5.5kW
	D

Field	Meaning			
	05: 48VDC 2: 230VAC	08: 80VDC 4: 400VAC	D1: 110VDC 6: 660VAC	1: 110VAC
E	Encoder type:			
	1: 2500-wire standard increment mode 5: Rotary transformer	2: 2500-wire increment mode	3: 17-bit one-loop absolute value	4: 17-bit multiple-loop absolute value
F	Communication:			
	R: RS485	C: CANOPEN	P: PROFIBUS-DP	
G	Reserved space			
	Products for special use and specific OEM product with protection Default: standard product			

1.4 Power specification

The power of each model is listed in the table below:

Table 1-2 Power specification of every model

Models	Input		Output	
	Capacity (kV/A)	Voltage (V)	Power (kW)	Rated current (A)
SV-DB100-0R2-2	0.5	Single /3-phase 230	0.2	1.8
SV-DB100-0R4-2	0.9	Single /3-phase 230	0.4	2.8
SV-DB100-0R7-2	1.3	Single /3-phase 230	0.75	4.5
SV-DB100-1R0-2	1.7	Single /3-phase 230	1.0	5.7
SV-DB100-1R5-2	2.5	3-phase 230	1.5	8.0
SV-DB100-2R0-2	3.5	3-phase 230	2.0	10.0
SV-DB100-1R0-4	1.9	3-phase 400	1.0	3.0
SV-DB100-1R5-4	2.9	3-phase 400	1.5	4.5
SV-DB100-2R0-4	3.9	3-phase 400	2.0	5.5
SV-DB100-3R0-4	4.8	3-phase 400	3.0	8.0
SV-DB100-4R4-4	6.2	3-phase 400	4.4	11.0
SV-DB100-5R5-4	7.5	3-phase 400	5.5	14.0

1.5 Illustrations of every parts of the servo drive

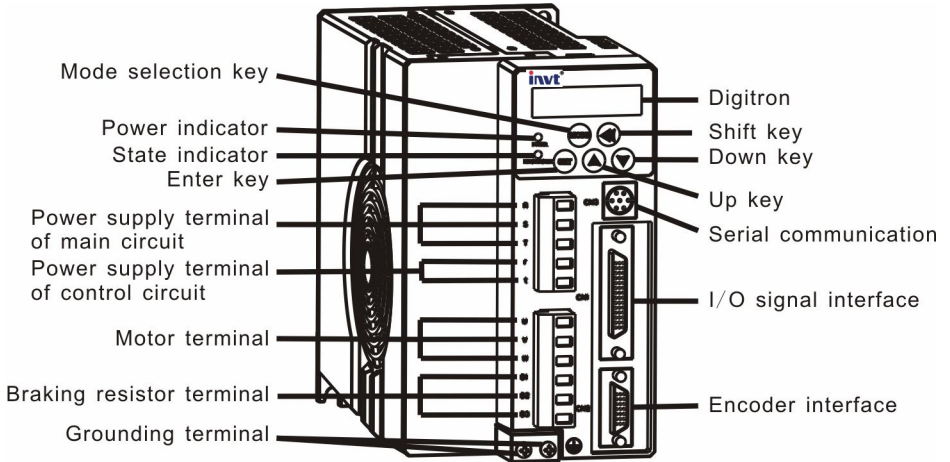

Fig. 1-3 Illustrations of every parts of 200W~5.5kW servo drives

1.6 External dimensions and installations sizes of the servo drive

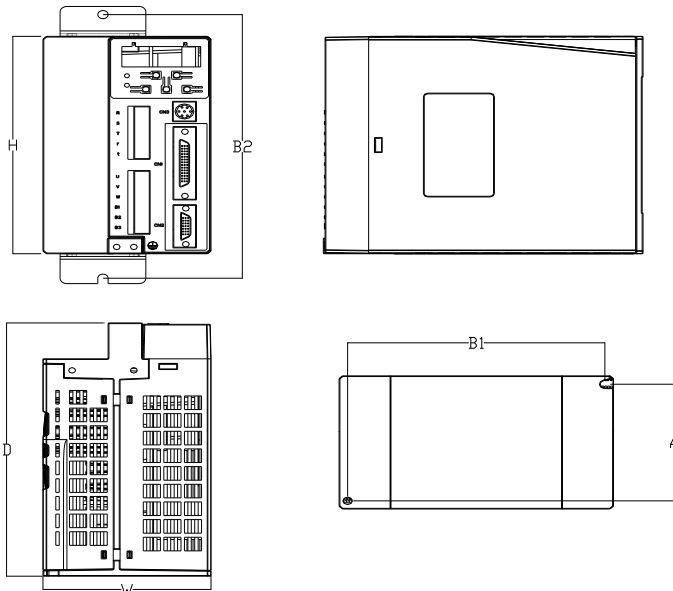

Fig. 1-4 External dimensions of 100W~5.5kW servo drive

Table 1-3 External dimensions and installations sizes

Models	External dimensions			Installation sizes			Installation hole (mm)
	H (mm)	W (mm)	D (mm)	A (mm)	B1 (mm)	B2 (mm)	
SV-DB100-0R2-2	160	68	186	56	150	194	5
SV-DB100-0R4-2							
SV-DB100-0R7-2	160	98	186	86	150	194	5
SV-DB100-1R0-2							
SV-DB100-1R5-2							
SV-DB100-2R0-2							
SV-DB100-1R0-4							
SV-DB100-1R5-4							
SV-DB100-2R0-4	230	110	186	98	219	264	5
SV-DB100-3R0-4							
SV-DB100-4R4-4							
SV-DB100-5R5-4							

2 Unpacking inspection



Note

- **Don't install or use any servo drive that is damaged or has fault parts, otherwise physical injury may occur.**

Check the following items after unpacking the servo drive and servo motor.

1. Inspect the entire exterior of the servo drive and servo motor to ensure there are no scratches or other damage caused by the transportation.
2. Ensure there is operational manual in the packing box.
3. Inspect the nameplate and ensure it is the right product.
4. Ensure the optional parts are the ordered ones.

Please contact the local agent if there is any damage to the servo drive and servo motor or optional parts.

3 Installation



Warning

- Only qualified electricians are allowed to operate on the drive device/system. Ignoring the instructions in “warning” may cause serious physical injury or death or property loss. Only qualified electricians are permitted to design, install, commission and operate on the device/system.
- Connect the input power lines tightly and permanently. And ground the device with proper techniques.
- Even when the servo drive is stopped, dangerous voltage is present at the terminals:
 - Power Terminals: R, S, T, r and t;
 - Motor Connection Terminals: U, V and W;
 - Regenerative Braking Resistor Connection Terminals: B1, B2 and B3.
- Stop the drive and disconnect it from the power line. Wait for 15 minutes to let the drive discharge and then begin the installation.



Note

- Install the servo drive on the non-flammable materials (such as metal) to prevent fire.
- Install a cooling fan to ensure the air temperature is lower than 45°C when two drives are needed in one cabinet. Otherwise fire or damage to the devices may occur.

3.1 Environmental Requirement

3.1.1 Temperature

Environment temperature range: 0°C ~ +45°C.

3.1.2 Relative humidity

RH ≤ 90%.

No condensation is allowed.

3.1.3 Altitude

The servo drive can run at the rated power if the installation site is less than 1000m (including 1000m) above the sea level. But it has to derate if the altitude exceeds 1000m. See the

following figure for details:

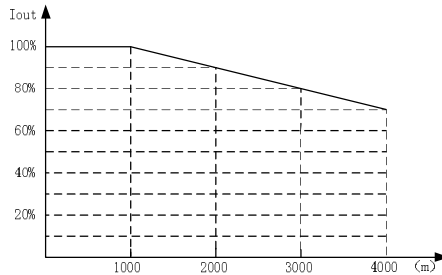

Figure 3.1 Relationship between output current and altitude

3.1.4 Other environment requirements

The servo drive can not bear fierce impact or shock. So the oscillation range should be less than 5.88m/s^2 (0.6g), 10Hz~60Hz.

The servo drive should keep away from the electromagnetic radiation source.

The servo drive should keep away from water and condensation.

The servo drive should keep away from contaminative air, such as corrosive gas, oil mist and conductive dust.

The servo drive should keep away from direct sunlight, oil mist, and steam and vibration environment.

3.2 Installation of the servo drive

3.2.1 Installation

The drive can be rack mounted. On the rear panel of the drive, there are two M5 mounting holes in the bottom left corner and top right corner to fix the drive tightly on a vertical plane.

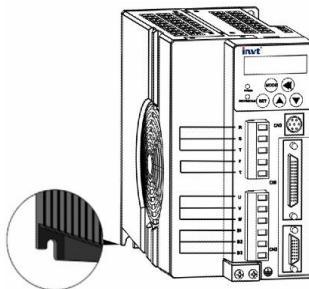

Fig. 3-2 Mounting holes of the servo drive

The servo drive can be shelf mountable by mounting bracket.

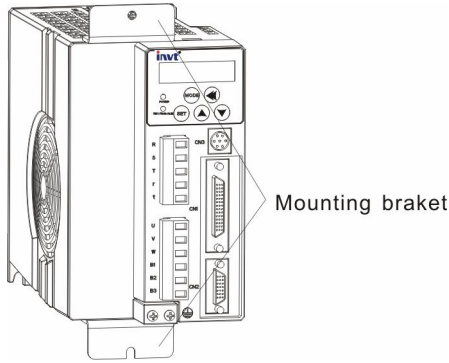

Fig. 3-3 Schematic diagram of the shelf mounting form of the servo drive

3.2.2 Installation direction and spacing

Please install the servo drive vertically and keep sufficient space around it for ventilation. If necessary, please fit a fan to control the temperature in the cabinet below 45°C.

1) To install only one set:

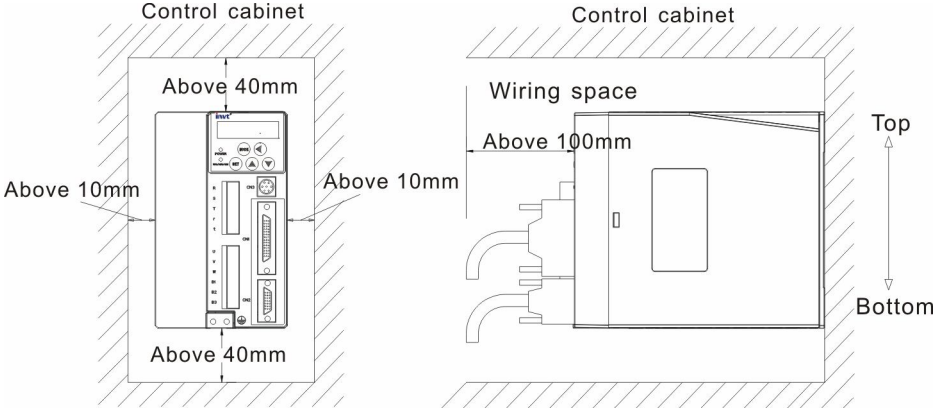

Fig. 3-4 Installation of single servo drive

2) To install several sets:

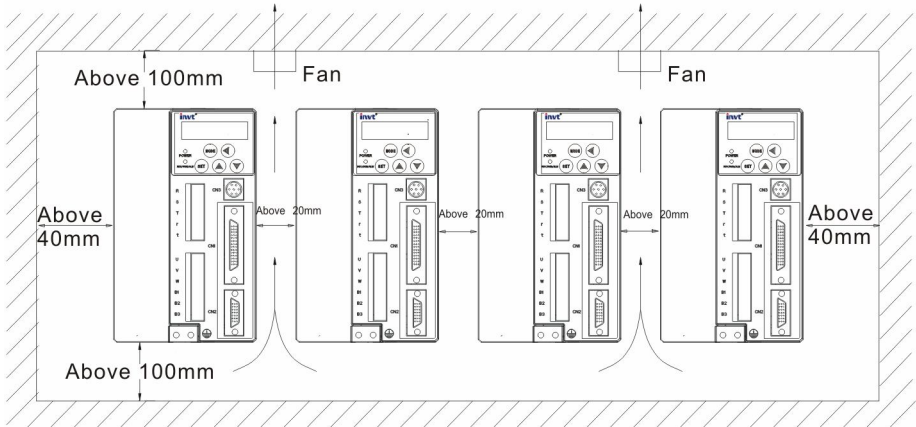

Fig. 3-5 Installation of several servo drives

3.2.3 Avoid intrusion of foreign objects

1. When assembling the control cabinet, do not allow metal chips to intrude into the servo drive.
2. Do not allow oil, water, metal chips and other foreign objects drop into the servo drive through the gaps between the control cabinet or the fan.
3. When the control cabinet is installed in a place with harmful gas or dust, ventilation is confirmedly required (to blow clean air into the control cabinet and keep the pressure inside is higher than outside) to avoid these matters coming into the control cabinet.

4 Signal and wiring



Warning

- Only qualified electricians are allowed to operate on the drive for the insurance of a safe running of the servo drive.
- Never carry out any insulation or voltage withstand tests on the cables connecting with the servo drive.
- Even if the servo drive is stopped, dangerous voltage is present at the input power lines, DC circuit terminals and motor terminals. Wait for 15 minutes even when the drive is switched off until is discharge before operation.
- Ground the grounding terminals of the drive with proper techniques. Otherwise there is danger of electrical shock and fire.
- Never do wiring or other operations on the servo drive with wet hands. Otherwise there is danger of electric shock



Note

- Verify that the rated voltage of the servo drive equals to the voltage of the AC power supply.
- The power wires and motor wires must be permanently fastened and connected.

4.1 System configuration

4.1.1 Connection diagram of the servo drive and external equipment

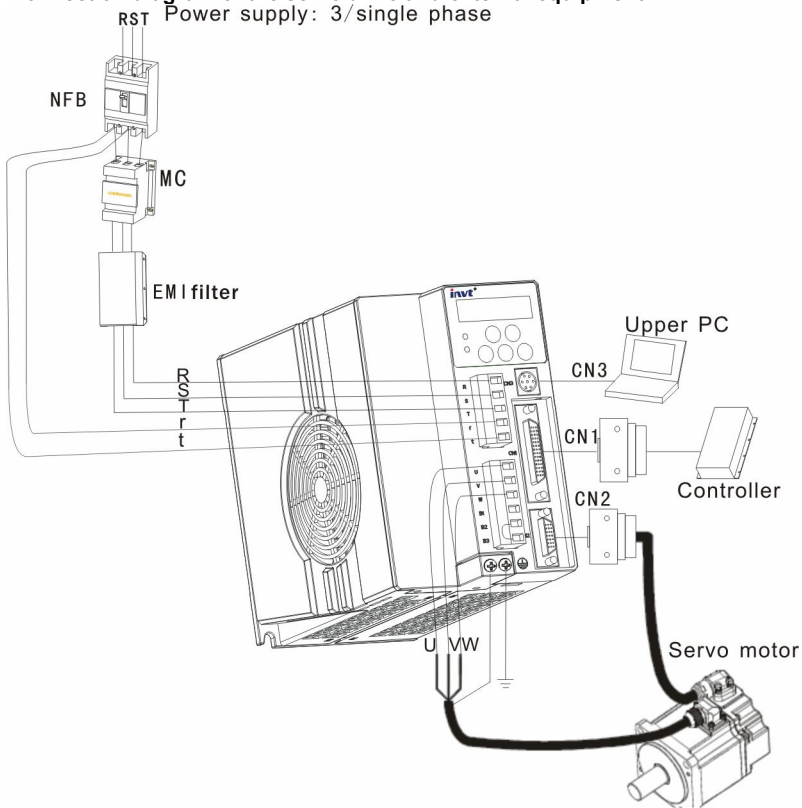

Fig. 4-1 Connection diagram of the servo drive and external equipment

- ◆ Check to ensure the input power supply indicated on the nameplate is the same as the grid before connecting the power supply of the drive.
- ◆ The electromagnetic contactor is used to switch on/off the power supply of the main circuit of the servo drive. Do not use it to start/stop the servo drive.
- ◆ In the figure above, the built-in regenerative braking resistor is used as default. If an external regenerative braking resistor is used, please refer to relevant wiring diagram. The regenerative braking resistor must be mounted on non-flammable materials, such as metal.

4.1.2 Cable diameter selection

Table 4-1 Cable diameter selection

Model	Cable diameter of the main circuit
SV-DB100-0R1-2	0.75~2.0mm ² AWG14 to AWG18
SV-DB100-0R2-2	
SV-DB100-0R4-2	
SV-DB100-0R7-2	2.0mm ² AWG14
SV-DB100-1R0-2	
SV-DB100-1R5-2	
SV-DB100-2R0-2	
SV-DB100-1R0-4	
SV-DB100-1R5-4	
SV-DB100-2R0-4	3.5mm ² AWG12
SV-DB100-3R0-4	
SV-DB100-4R4-4	
SV-DB100-5R5-4	

Notes:

1. Cable diameter is the diameter of copper cables.
2. The diameter of the protective grounding wire: not less than 2.0mm²(AWG14) for 100W~2.0kW models; not less than 3.5mm²(AWG12) for 3.0kW~4.4kW models; not less than 5.3mm²(AWG10) for 5.5 kW model.

4.1.3 EMI filter selection

Table 4-2 EMI filter selection

Drives	EMI filters
SV-DB100-0R2-2	FLT-P04016L-B
SV-DB100-0R4-2	
SV-DB100-0R7-2	
SV-DB100-1R0-2	
SV-DB100-1R5-2	
SV-DB100-2R0-2	
SV-DB100-1R0-4	
SV-DB100-1R5-4	
SV-DB100-2R0-4	
SV-DB100-3R0-4	
SV-DB100-4R4-4	

Drives	EMI filters
SV-DB100-5R5-4	

Note: The EMI filter modules in the table means the filter product modules of INVT.

4.1.4 Braking resistor selection

Table 4-3 Braking resistor selection

Drives	Internal braking resistors	Recommended External Braking Resistors	The allowed external Minimum braking resistors
SV-DB100-0R2-2	47Ω 80W	60Ω 200W	40Ω
SV-DB100-0R4-2	47Ω 80W	60Ω 400W	40Ω
SV-DB100-0R7-2	47Ω 80W	40Ω 750W	40Ω
SV-DB100-1R0-2	47Ω 80W	30Ω 1.0kW	25Ω
SV-DB100-1R5-2	20Ω 80W	20Ω 1.0kW	15Ω
SV-DB100-2R0-2	20Ω 80W	20Ω 1.0kW	15Ω
SV-DB100-1R0-4	100Ω 80W	80Ω 1.0kW	80Ω
SV-DB100-1R5-4	47Ω 80W	50Ω 1.0kW	47Ω
SV-DB100-2R0-4	47Ω 80W	50Ω 1.0kW	47Ω
SV-DB100-3R0-4	47Ω 80W	40Ω 2.0kW	30Ω
SV-DB100-4R4-4	47Ω 80W	40Ω 2.0kW	30Ω
SV-DB100-5R5-4	47Ω 80W	40Ω 2.0kW	30Ω

4.2 Wiring of the main circuit (Plug X1 and X2)

4.2.1 Overview

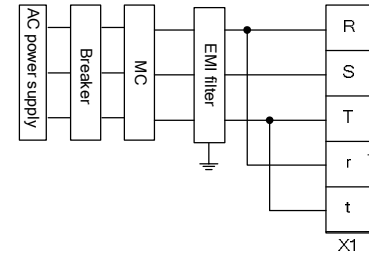

- Check whether the phase number/voltage grade of the AC power supply are consistent with those identification on the nameplate of the drive.
- Non-fuse breaker or leakage switch.
- Do not use this electromagnetic contactor to start/stop the servo drive.

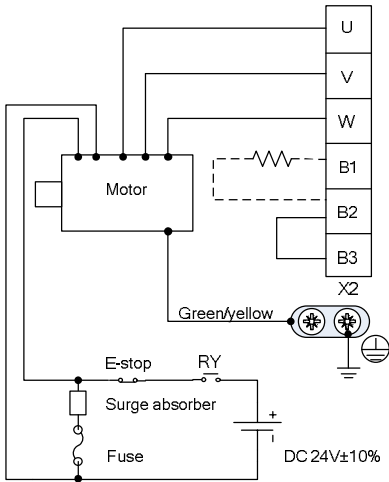

- Correctly connect to output U, V, and W of the drive according to the phase sequence of the motor cable of the servo motor. Wrong phase sequence will cause drive fault.
- Do not disconnect the short circuit wire between B2 and B3 unless an external regenerative braking resistor is used.
- When an external regenerative braking resistor is used, disconnect the short circuit wire between B2 and B3, and connect it according to the dashed in the figure.
- Be sure to ground the servo drive with proper techniques to avoid the accident of electrical shock.
- Please set a circuit which can activate the electromagnetic brake not only through the servo drive but also through the external emergency stop device. Please refer to section 4.6.
- The electromagnetic brake uses 24V power supply which should be provided by the user. Do not share it with the control signal power supply. pow

The distance between the servo motor and the servo drive should not exceed 20m. Keep a distance of at least 30cm between the encoder wire, motor cable and power cable.

Fig. 4-2 Wiring diagram of the main circuit

4.2.2 Wiring diagram of single phase 230V power input

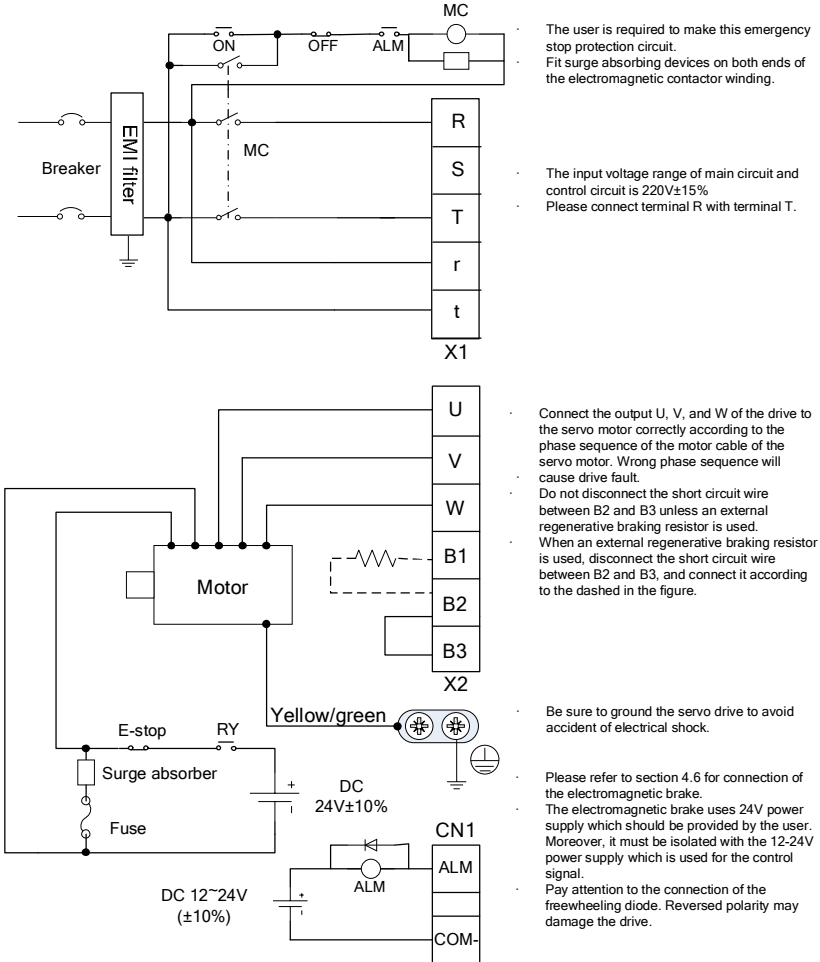
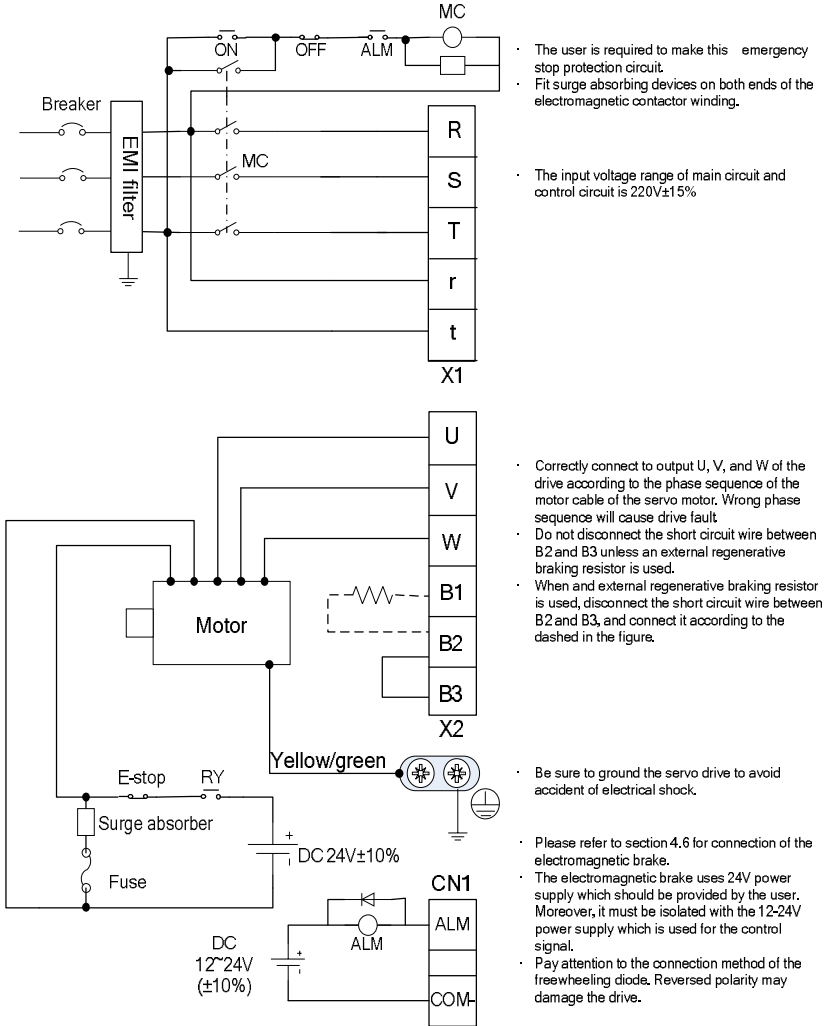

Fig. 4-3 Wiring diagram of single phase 230V power input

4.2.3 Wiring diagram of three-phase 230V power input



- The user is required to make this emergency stop protection circuit.
- Fit surge absorbing devices on both ends of the electromagnetic contactor winding.
- The input voltage range of main circuit and control circuit is 220V±15%
- Correctly connect to output U, V, and W of the drive according to the phase sequence of the motor cable of the servo motor. Wrong phase sequence will cause drive fault.
- Do not disconnect the short circuit wire between B2 and B3 unless an external regenerative braking resistor is used.
- When an external regenerative braking resistor is used, disconnect the short circuit wire between B2 and B3, and connect it according to the dashed in the figure.
- Be sure to ground the servo drive to avoid accident of electrical shock.
- Please refer to section 4.6 for connection of the electromagnetic brake.
- The electromagnetic brake uses 24V power supply which should be provided by the user. Moreover, it must be isolated with the 12-24V power supply which is used for the control signal.
- Pay attention to the connection method of the freewheeling diode. Reversed polarity may damage the drive.

Fig. 4-4 Wiring diagram of three-phase 230V power input

4.2.4 Wiring diagram of three-phase 400V power input

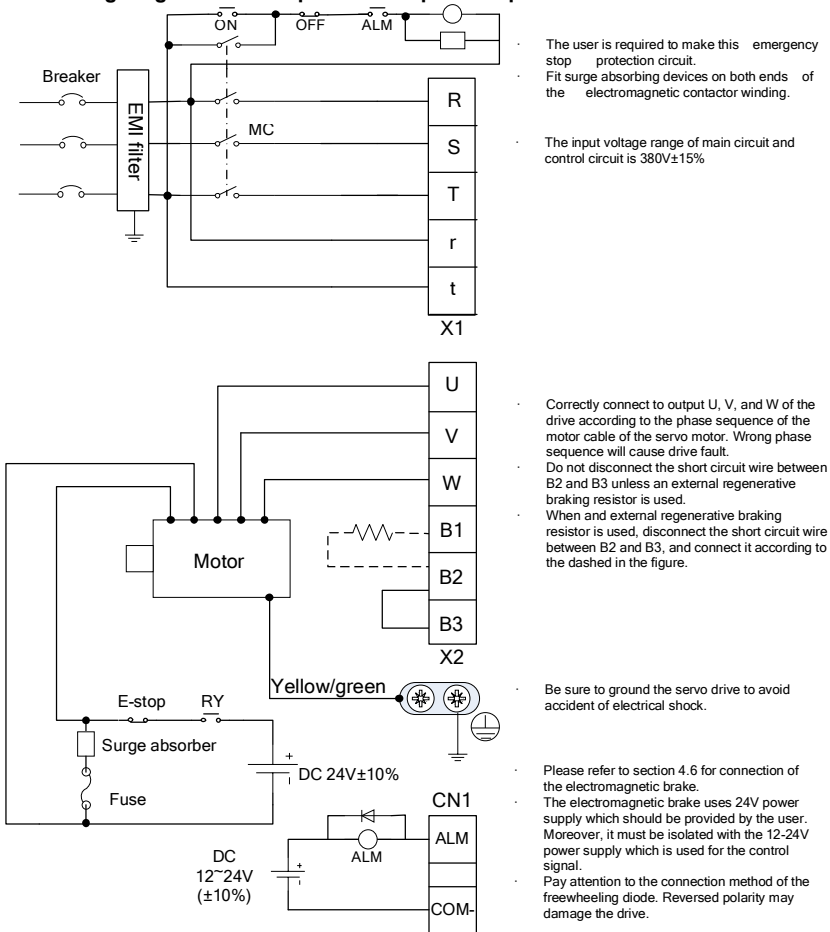

- The user is required to make this emergency stop protection circuit.
- Fit surge absorbing devices on both ends of the electromagnetic contactor winding.
- The input voltage range of main circuit and control circuit is 380V±15%
- Correctly connect to output U, V, and W of the drive according to the phase sequence of the motor cable of the servo motor. Wrong phase sequence will cause drive fault.
- Do not disconnect the short circuit wire between B2 and B3 unless an external regenerative braking resistor is used.
- When an external regenerative braking resistor is used, disconnect the short circuit wire between B2 and B3, and connect it according to the dashed in the figure.
- Be sure to ground the servo drive to avoid accident of electrical shock.
- Please refer to section 4.6 for connection of the electromagnetic brake.
- The electromagnetic brake uses 24V power supply which should be provided by the user. Moreover, it must be isolated with the 12-24V power supply which is used for the control signal.
- Pay attention to the connection method of the freewheeling diode. Reversed polarity may damage the drive.

Fig. 4-5 Wiring diagram of three-phase 400V power input

4.3 Wiring of the encoder (plug CN2)

4.3.1 Overview

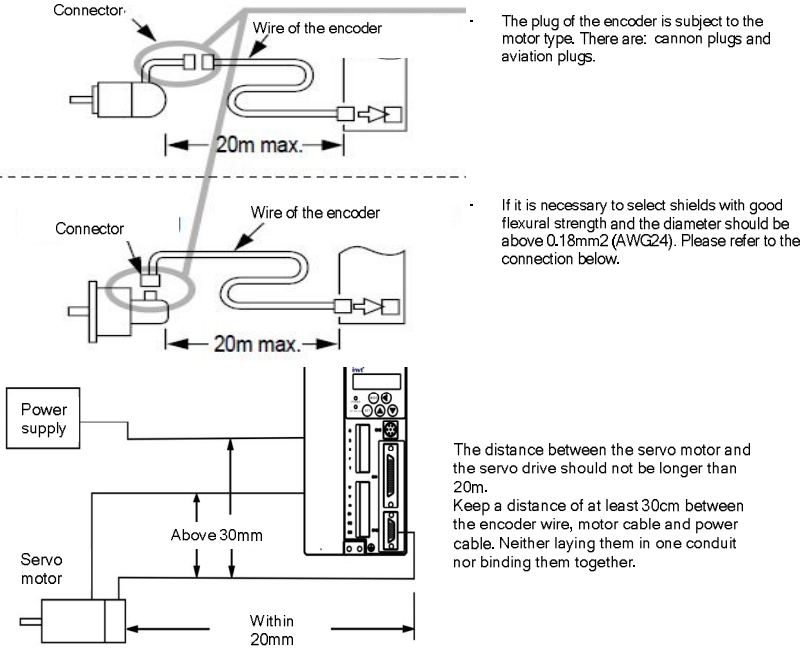

Fig. 4-6 Wiring of the encoder signal

4.3.2 CN2 pin arrangement and signal definition of the servo drive

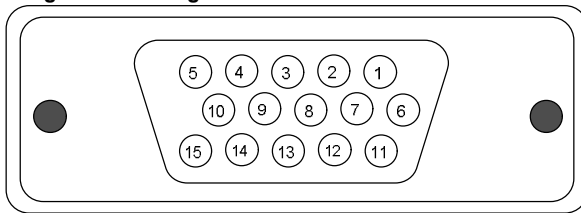

Fig. 4-7 CN2 pin arrangement

Table 4-2 CN2 signal definition table

CN2 pin No.	Definition	Cable color
1	V+	Black
2	W+	Brown
3	A+	Red

CN2 pin No.	Definition	Cable color
4	A-	Red and white
5	5V	Purple
6	U+	Orange
7	V-	Black and white
8	W-	Brown and white
9	B-	Blue
10	B+	Blue and white
11	U-	Orange and white
12	GND	Purple and white
13	Z-	Green
14	Z+	Green and white
15	/	/

4.4 Connection with the PC or HOST (CN3 plug)

The servo drive provides two kinds of communication interface: RS232 and RS485, both are drawn out via the plug CN3.

CN3 pin arrangement and signal definition:

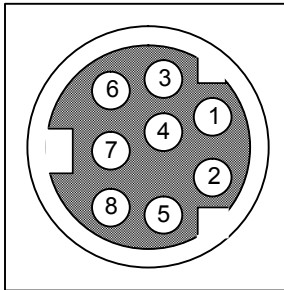

Fig. 4-8 CN3 pin arrangement

Table 4-3 CN3 signal definition table

CN3 pin No.	1	2	3	4	5	6	7	8
Definition	RXD	GND	TXD	CANL	/	CANH	RS485-	RS485+

4.5 I/O signal wiring (CN1 connector)

4.5.1 Overview

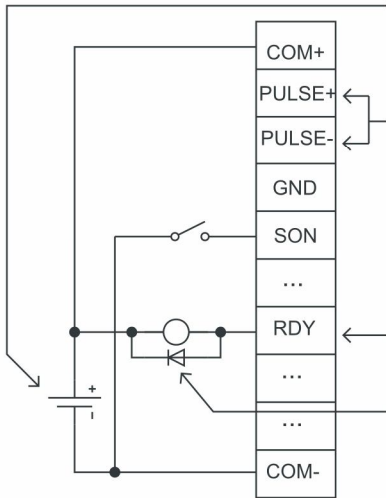
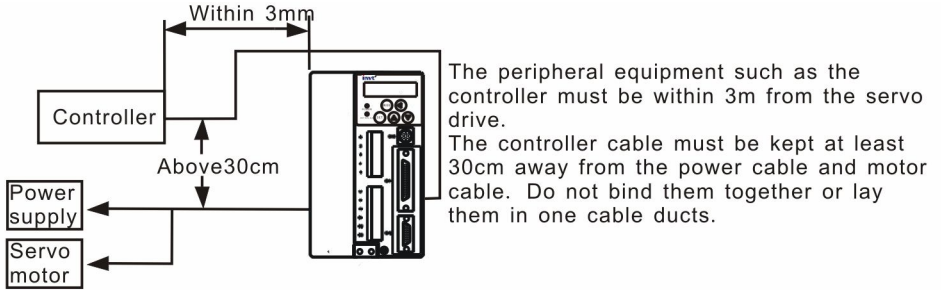

The user is recommended to prepare the 12-24V DC power supply of 500mA or more capacity used for control signal. The local 24V power supply of the drive can only provide 100mA current. The signal wires for pulse command input and encoder output should adopt shielded twisted pair.

Do not apply a voltage higher than 30V or a load over 50mA on the digital output terminal. The digital output signals drives inductive loads directly such as relay, etc. Be sure to fit a freewheeling diode on each end of the load.

Fig. 4-9 Input/output signal connection

4.5.2 CN1 pin arrangement and signal explanation

4.5.2.1 CN1 terminal definition

			16	SON	Servo enabling			
1	MCH	Switching of the control mode	17	SC2	Speed selection 2 /electrical gear selection 2	31	OCS	Command pulse input 1(selected)
2	COM+	Power supply of the control signal +	18	RPC	Speed reverse /retention pulse clearance	32	SIGN+	Command pulse input 2
3	PSL	Forward travel limit	19	GND	Signal ground	33	SIGN-	Command pulse input 2
4	RVL	Reverse travel limit	20	VA+	Analog input 1	34	SC1	Speed selection 1 /electrical gear selection 1
5	VA-	Analog input 1	21	AO1	Analog input 1	35	GND	Signal ground
6	TQC	Torque limit selection	22	PLL	Analog input inhibit	36	PLC	Gain switching
7	TA+	Analog input 2	23	PULSE+	Command pulse input 1	37	ZRS	Zero position
8	TA-	Analog input 2	24	PULSE-	Command pulse input 1	38	OCP	Command pulse input 2(selected)
9	BRK	Breaker release	25	AO2	Analog output 2	39	EMG	E-stop

10	CLA	Alarm clear	26	OCZ	Z phase collector output	40	24V	Local 24V
11	PLR	Position arrival	27	OZ-	Z phase output	41	OB+	B phase output
12	COM-	Power supply of the control signal -	28	OZ+	Z phase output	42	OB-	B phase output
13	LM	Torque limit	29	ZSO	Zero speed	43	OA-	A phase output
14	RDY	Servo ready	30	SR	Speed arrival	44	OA+	A phase output
15	ALM	Servo alarm						

4.5.2.2 CN1 See the figure below for CN1 pin signals:

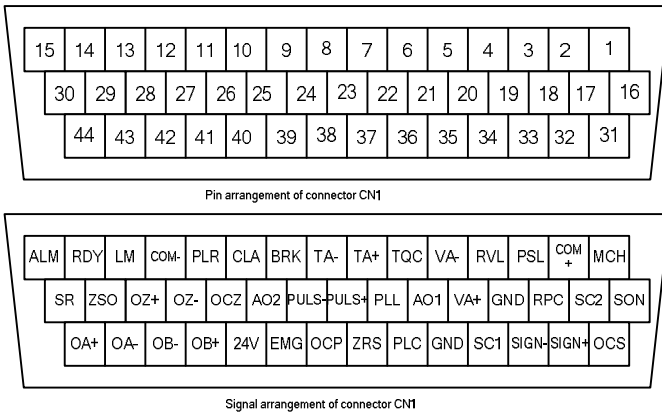

Fig. 4-10 CN1 pin signal diagram

4.5.2.3 Power signal

Table 4-6 Power signal table

Symbol	Pin No.	Name	Function
24V	40	24V power supply	It's supplied by the drive. COM- is the ground terminal of the 24V power. Its capacity is 100mA. If the actual load is higher than this value, the user shall provide the

Symbol	Pin No.	Name	Function
			power supply by themselves.
GND	19, 35	Signal ground	The ground of the internal power supply (except the 24V power supply) of the servo drive, it is also the ground of the phase Z open-collector signal of the encoder and the analog output signal. It is isolated with COM-.
COM+	2	Positive pole of external DC power 12V~24V	If the DC power supply is provided by the user, the positive pole of the DC power supply must be connected to this terminal. If the 24V power supply of the drive is used, the 24V terminal (pin 40) must be connected on this terminal.
COM-	12	Negative pole of the power	Local 24V; Negative pole of the external power 12V~24V
FG	Cassie	Cassie ground	The cassis of CN1 terminal is connected with that of the drive.

4.5.2.4 Digital input signals and their functions

Table 4-7 Function table of digital input signals

Symbol	Pin No.	Name	Function	Mode
CLA	10	Alarm clear	When a fault alarm occurs, this terminal can be short-connected with COM-. If the fault condition is removed, the fault alarm display will be cleared. If the fault condition is not removed, the fault will be reported again. Please remove the fault and short connect this terminal with COM- again. In this way the fault alarm display will be cleared. Note: This terminal signal takes effect when receiving a pulse.	P.S.T
EMG	39	Emergency stop	When parameter FP3.41 (E-stop masking) is set as 1, i.e. Emergency stop terminal signal is active, this terminal can be used to execute	P.S.T

Symbol	Pin No.	Name	Function	Mode												
			<p>emergency stop function: after disconnecting this terminal with COM-, the servo drive cuts off the output, the servo motor coast to stop and Emergency stop warning will occur. After emergency stopping, even if this terminal recovers short-circuit with COM-, it needs to enable the servo to run the drive. If internal servo enabling is used, it needs to switch on the control power again and then activate the internal servo enabling. This terminal signal takes effect when receiving a pulse.</p> <p>When parameter FP3.41 is set as 0, Emergency stop terminal signal is invalid.</p> <p>Note: This terminal signal takes effect when receiving a pulse.</p>													
MCH	1	Control mode switching	<p>When parameter FP0.03 (control mode selection) is set as 3~5, this terminal can be used to switch between different controls modes. The corresponding relationships of this terminal's state and the control modes are listed in the table below:</p> <table border="1"> <thead> <tr> <th>Value of parameter FP0.03</th> <th>MCH is disconnected with COM-</th> <th>MCH is connected with COM-</th> </tr> </thead> <tbody> <tr> <td>3</td> <td>Position control mode</td> <td>Speed control mode</td> </tr> <tr> <td>4</td> <td>Speed control mode</td> <td>Torque control mode</td> </tr> <tr> <td>5</td> <td>Position control mode</td> <td>Torque control mode</td> </tr> </tbody> </table>	Value of parameter FP0.03	MCH is disconnected with COM-	MCH is connected with COM-	3	Position control mode	Speed control mode	4	Speed control mode	Torque control mode	5	Position control mode	Torque control mode	P.S.T
Value of parameter FP0.03	MCH is disconnected with COM-	MCH is connected with COM-														
3	Position control mode	Speed control mode														
4	Speed control mode	Torque control mode														
5	Position control mode	Torque control mode														
PLC	36	Gain switching	<p>When parameter FP2.22 (gain switching condition) is set as 0, i.e. manual gain switching, this terminal can be used to switch</p>	P.S.T												

Symbol	Pin No.	Name	Function	Mode
			gain. Parameter FP2.21 is used to select the type of gain switching. See the explanation of FP2.21 and FP2.22 for details.	
PLL	22	Pulse input disabling	<p>In position control mode, this terminal can be used to disable input of position pulse signal, i.e. the inputted position pulse signal is invalid.</p> <p>When this terminal is short-circuited with COM-, pulse input is disabled, and the servo is in locked state. When this terminal is disconnected with COM-, pulse input is allowed, and the servo can run.</p> <p>Note: This terminal signal takes effect when receiving a pulse.</p>	P
PSL	3	Forward travel limitation	<p>When parameter FP3.40 is set as 1, i.e. the signal of travel limitation terminal is active, this terminal can be used to execute forward travel limitation function:</p> <p>When this terminal is disconnected with COM-, the forward speed will return to zero immediately and a forward travel limitation alarm will occur until the forward travel limitation terminal recovers short-circuit with COM-. In the forward travel limitation, the drive can automatically respond to the reverse speed command. This terminal signal takes effect when receiving a pulse.</p> <p>In the speed mode and torque mode, the servo is in zero speed clamp state.</p> <p>In the position mode, the servo is in locked state.</p> <p>When parameter FP3.40 is set as 0, this travel limitation terminal signal is invalid.</p>	P.S.T

Symbol	Pin No.	Name	Function	Mode
RPC	18	Speed reversing/retention pulse clearing	<p>In the speed mode, short connecting this terminal with COM- can reverse the direction of the internal speed command and analog speed command.</p> <p>In the position mode, short connecting this terminal with COM- can clear the position command pulse counter, the position feedback pulse counter, and the position deviation pulse counter.</p> <p>This terminal signal takes effect when receiving a pulse.</p>	P.S
RVL	4	Reverse travel limitation	<p>When parameter FP3.40 (Travel limit switch masking) is set as 1, i.e. the travel limitation terminal signal is active, this terminal can be used to execute reverse travel limitation function:</p> <p>When this terminal is disconnected with COM-, the reverse speed will return to zero immediately and a reverse travel limitation alarm will occur until the forward travel limitation terminal recovers short-circuit with COM-. In reverse travel limitation, the drive can automatically respond to the positive speed command. This terminal signal takes effect when receiving a pulse.</p> <p>In the speed mode and torque mode, the servo is in zero speed clamp state.</p> <p>In the position mode, the servo is in locked state.</p> <p>When parameter FP3.40 is set as 0, this travel limit terminal signal is invalid.</p>	P.S.T

Symbol	Pin No.	Name	Function	Mode																					
SC1	34	Speed option 1/electronic gear option 1	Internal speed command (speed mode)/speed limit (torque mode) or electronic gear (position mode) is selected by combination of these two terminal signals as listed in the table below (ON indicates SCX is short-circuited with COM-, OFF indicates SCX is open-circuited with COM- (X=1 or 2)):	P.S.T																					
SC2	17	Speed option 2/electronic gear option 2			<table border="1"> <thead> <tr> <th>SC2</th> <th>SC1</th> <th>Speed/torque mode</th> <th>Position mode</th> </tr> </thead> <tbody> <tr> <td>OFF</td> <td>OFF</td> <td>Internal speed/speed limit 1</td> <td>Electronic gear 1</td> </tr> <tr> <td>OFF</td> <td>ON</td> <td>Internal speed/speed limit 2</td> <td>Electronic gear 2</td> </tr> <tr> <td>ON</td> <td>OFF</td> <td>Internal speed/speed limit 3</td> <td>Electronic gear 3</td> </tr> <tr> <td>ON</td> <td>ON</td> <td>Internal speed/speed limit 4</td> <td>Electronic gear 4</td> </tr> </tbody> </table>	SC2	SC1	Speed/torque mode	Position mode	OFF	OFF	Internal speed/speed limit 1	Electronic gear 1	OFF	ON	Internal speed/speed limit 2	Electronic gear 2	ON	OFF	Internal speed/speed limit 3	Electronic gear 3	ON	ON	Internal speed/speed limit 4	Electronic gear 4
					SC2	SC1	Speed/torque mode	Position mode																	
					OFF	OFF	Internal speed/speed limit 1	Electronic gear 1																	
					OFF	ON	Internal speed/speed limit 2	Electronic gear 2																	
ON	OFF	Internal speed/speed limit 3	Electronic gear 3																						
ON	ON	Internal speed/speed limit 4	Electronic gear 4																						
SON	16	Servo enabling	External servo enabling can be conducted by this terminal: the drive is in servo enabling state after this terminal is short-circuited with COM-. After switching on the power, the motor will run according to the command of the drive. After this terminal is disconnected with COM-, the drive will disconnect the output and the motor will stop. This terminal signal takes effect when receiving a pulse. When this terminal is disconnected with COM-, internal servo enabling can be conducted through parameter FP0.04. See the explanation of parameter FP0.04 for details. Note: After SON is short-circuited with COM-,	P.S.T																					

Symbol	Pin No.	Name	Function	Mode
			<p>please wait for at least 100ms before entering any command pulse;</p> <p>When SON is disconnected with COM-, the position deviation counter is cleared off.</p> <p>Try best to avoid to starting/stopping the servo drive with this terminal continually. The drive can be started/stopped with the zero speed clamp terminal (ZRS). See function description of terminal ZRS for details.</p>	
TQC	6	Torque limit selection	<p>In the speed or position mode, if parameter FP0.04=0, when this terminal is short-circuited with COM-, the torque limit command is external analog torque limit, when this terminal is disconnected with COM-, the torque limit command is internal torque limit, and the value is given by parameter FP0.12. If parameter FP0.04=1, the torque limit command is internal torque limit, this terminal signal is inactive.</p>	P.S

In the table above: the polarity of terminals SON, ZRS, CLA, PLL, and RPC can be reversed by setting parameter FP3.00. See the explanation of FP3.00 in chapter 6.4.

4.5.2.5 Pulse input signals and their functions

Table 4-8 Function table of pulse input signals

Symbol	Pin No.	Name	Function
OCP	38	Position command pulse input 1	<p>In the position control mode, they are used as the input terminals of the position command;</p> <p>In other control modes, this group of terminals is inactive;</p> <p>Allowed Max. input pulse frequency: 500kHz in differential mode, 200kHz in open-collector mode.</p>
PULSE+	23		
PULSE-	24		
OCS	31	Position command pulse input 2	
SIGN+	32		
SIGN-	33		

4.5.2.6 Pulse input signals and their functions

Table 4-9 Function table of analog input signals

Symbol	Pin No.	Name	Function
VA+	20	Position command pulse input 1	External analog input terminals. The input impedance is 10kΩ. The input voltage range is -10V~+10V. A voltage exceeding ±11V may damage the drive. Refer to parameters of FP0.42, FP0.62 and FP3.20, FP3.23.
VA-	5		
TA+	7	Position command pulse input 2	
TA-	8		

4.5.2.7 Digital output signals and their functions

Table 4-10 Function table of digital output signals

Symbol	Pin No.	Name	Function
ALM	15	Servo alarm	When the servo drive is in normal state, this signal output transistor is breakover. When the power supply is disconnected or the servo drive is in alarm state, this signal output transistor switches off.
LM	13	Torque limit	When the servo system is in torque limit, this signal output transistor is breakover.
PLR	11	Position reaching	When the position reaches to the command range, this signal output transistor is breakover.
BRK	9	Brake releasing	When it comes into the brake releasing sequence and needs to release the brake, this signal output transistor is breakover.
RDY	14	Servo ready	When the control power and main power are applied normally and the drive is not in alarm state, this signal output transistor is breakover, it means the drive can be started.
SR	30	Speed reaching	When the speed reaches the range of speed setting, this signal output transistor is breakover.
ZSO	29	Zero speed	When the speed reaches the range of zero speed, this signal output transistor is breakover.

4.5.2.8 Digital output signals and their functions

Table 4-11 Function table of encoder output signals

Symbol	Pin No.	Name	Function
--------	---------	------	----------



Symbol	Pin No.	Name	Function
OA+	44	Phase A output	<ul style="list-style-type: none"> Output the frequency divided encoder signal, comply with the standard of TIA/EIA-422-B;
OA-	43		
OB+	41	Phase B output	<ul style="list-style-type: none"> The output phase A pulse and phase B pulse is still orthogonal. When it rotates forward, phase B leads phase A by 90°. When it rotates in reverse, phase A leads phase B by 90°.
OB-	42		
OZ+	28	Phase Z output	<ul style="list-style-type: none"> The frequency division coefficient of phase A and phase B can be set through parameter FP0.06 and FP0.07. Frequency division with any integer and decimal fraction is allowable but frequency multiplication is not allowed; The output signals have no isolation.
OZ-	27		
OCZ	26		

4.5.2.9 Analog output signals and their functions

Table 4-12 Function table of analog output signals

Symbol	Pin No.	Name	Function
AO1	21	Analog output 1	Its output function can be defined by setting parameter of FP3.30. The range and deviation can be set via parameters FP3.31 and FP3.34.
AO2	25	Analog output 2	Its output function can be defined by setting parameter of FP3.32. The range and deviation can be set via parameters FP3.33 and FP3.35.

4.5.5 Standard wiring of the torque control mode

Note:
 is the twisted shields
 is the power supply which
 is prepared by the user.

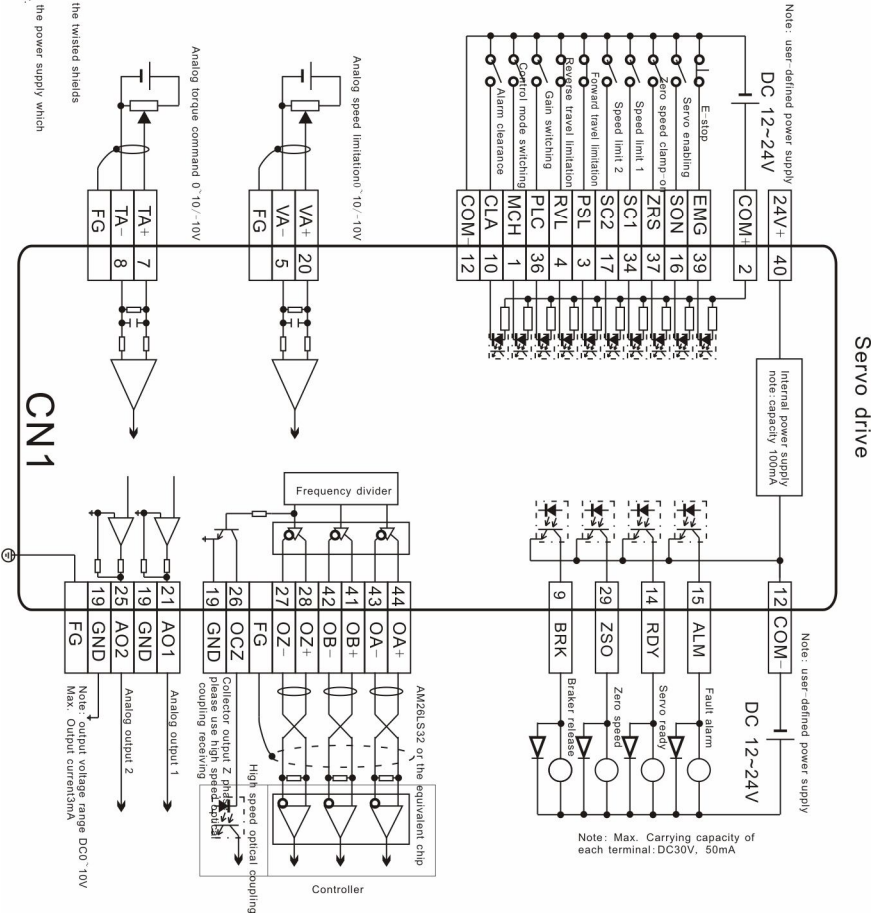

Fig. 4-13 Standard wiring of the torque control mode

4.5.6 Detailed instruction of the input and output of CN1

4.5.6.1 Wiring of ON-OFF input circuit

Connection diagram when the power supply is self-provided by user:

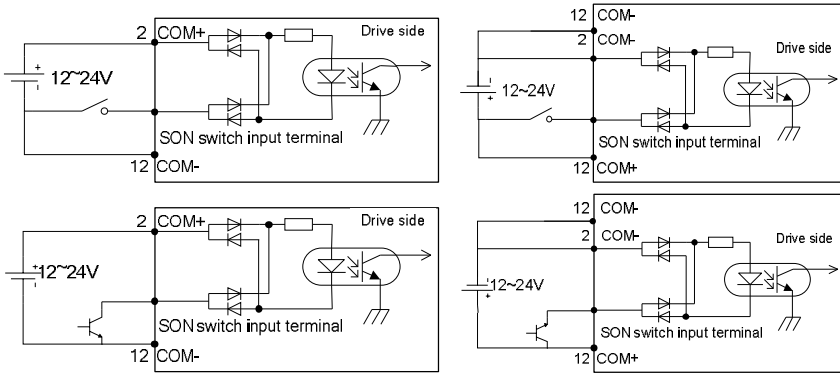

Fig. 4-14 Wiring diagram of ON-OFF input circuit (power supply is self-provided by user)

Connection diagram when the local power supply is used:

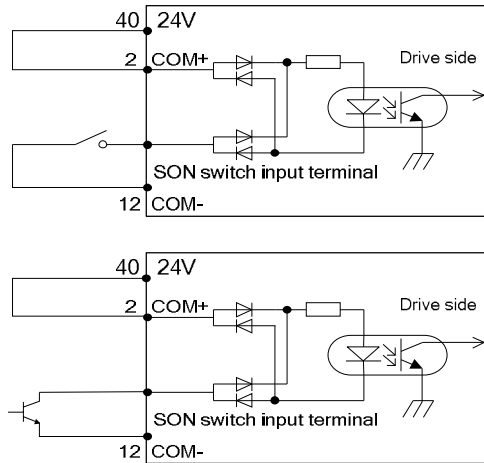

Fig. 4-15 Wiring diagram of ON-OFF input circuit (local power supply)

- ◆ The ON-OFF input circuit can be connected with mechanical switch connection and the open-collector connection of audion shown in the figure.
- ◆ The user can use either the 24V power supply (it only can provide 100mA current) of the servo drive or 12V~24V power supply provided by the user.

4.5.6.2 Wiring of the pulse input circuit

Connect method 1: the differential connection

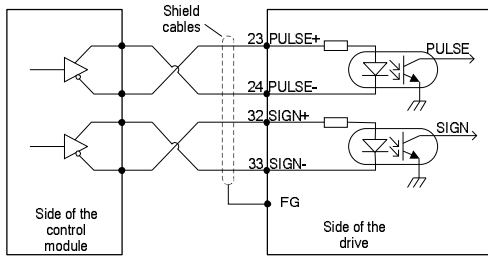

Fig. 4-16 Wiring diagram of differential pulse input circuit

- ◆ The maximum frequency of input pulse is 500kHz and the input signal voltage is $\pm 5v$;
- ◆ With the best anti-noise capability, this signal transmit method is recommended as the preferred.

Connection method 2: the open collector circuit 1

The control module is NPN (the common negative pole):

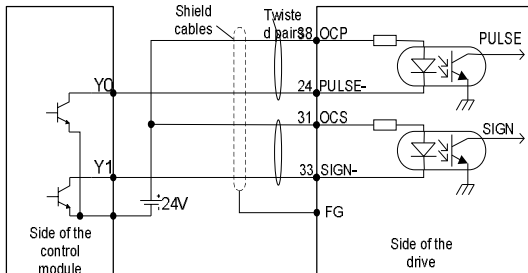

Fig. 4-17 Wiring diagram of the open collector circuit 1(NPN)

The control module is PNP module (the common positive pole):

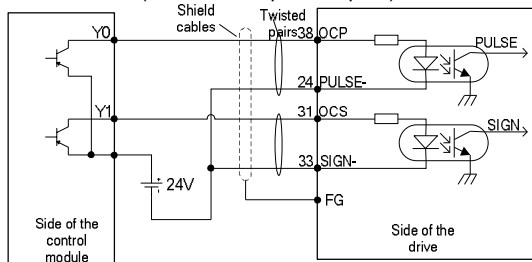

Fig. 4-18 Wiring diagram of the open collector circuit 1(PNP)

- ◆ The Max. input pulse frequency is 200kHz; apply the local 24v power supply((it only can provide 100mA current)) or the user-provided 24v power supply without the current-limiting resistor. Generally, most of Japanese PLC (such as Mitsubishi, Panasonics and OMRON) is NPN module, while most of European PLC (such as

Siemens) is PNP module. The above figure is external 24V power supply connection. If the internal power supply is needed, connect the pin of the positive terminal of 24V power supply and the pin of 24V power supply (the 40 pins of CN1) of the drive and connect the pin of the negative terminal of 24V power supply and COM-(the 12 pins of CN1).

Connection method 3: the open collector circuit 2

The control module is NPN (the common negative pole):

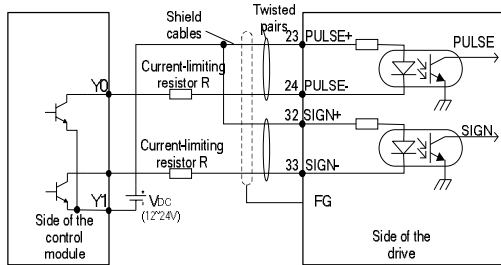

Fig. 4-19 Wiring diagram of the open collector circuit 2(NPN)

The control module is PNP (the common positive pole):

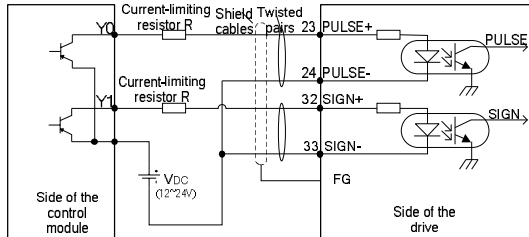

Fig. 4-20 Wiring diagram of the open collector circuit 2(PNP)

- ◆ The Max. input pulse frequency is 200kHz; apply the local 24v power supply((it only can provide 100mA current)) or the user-provided 24v power supply with the current-limiting resistor(the resistance is selected as the below table). Generally, most of Japanese PLC (such as Mitsubishi, Panasonic and OMRON)is NPN module, while most of European PLC (such as Siemens)is PNP module. The above figure is external 24V power supply connection. If the internal power supply is needed, connect the pin of the positive terminal of 24V power supply and the pin of 24V power supply (the 40 pins of CN1) of the drive and connect the pin of the negative terminal of 24V power supply and COM-(the 12 pins of CN1).

VDC	Resistor parameters	$V_{DC} = 1.5$ $R + 68 \approx 100 \text{ mA}$
12V	1K Ω ,1/4W	
24V	2K Ω ,1/3W	

For all the 3 methods, shielded twisted-pair must be used and the length must be less than 3m.

4.5.6.3 Wiring of the analog input circuit

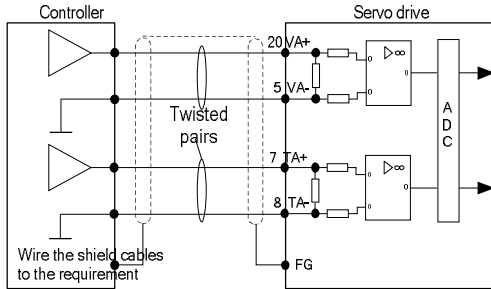

Fig. 4-21 Wiring diagram of the analog input circuit

- ◆ There are two analog input circuits VA and TA. The input impedance is 10k Ω . The input voltage range is -10V~+10V. If the voltage is higher than $\pm 11V$, the circuits may damage.

4.5.6.4 Wiring of ON-OFF output circuit

Connection diagram when the power supply is self-provided by user:

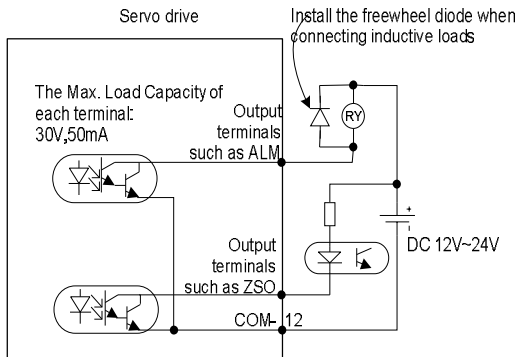

Fig. 4-22 Wiring diagram of ON-OFF output circuit (power supply is self-provided by user)

Connection method when the local power supply is used:

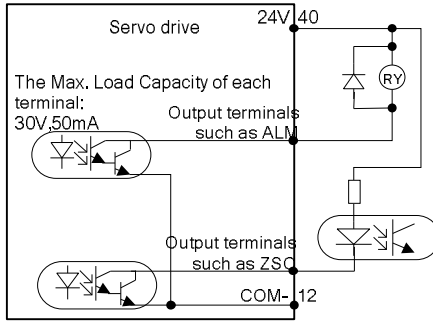

Fig. 4-23 Wiring diagram of ON-OFF output circuit (local power supply)

- ◆ There are 7 digital output circuits in total and all of them adopt the open-collector output as shown in the figure. They can be used to drive the relay coil or optical coupled load. The loading capacity is as shown in the figure.
- ◆ When inductive loads such as relay coil are connected, a freewheel diode must be fitted as shown in the figure. Otherwise the drive will be damaged.
- ◆ The local 24V power supply only can provide 100mA current. If the actual load current is larger than 100mA, the user should provide the power supply by themselves. The recommended capacity is greater than 500mA.

4.5.6.5 Wiring of the frequency division output circuit of the encoder feedback signal:

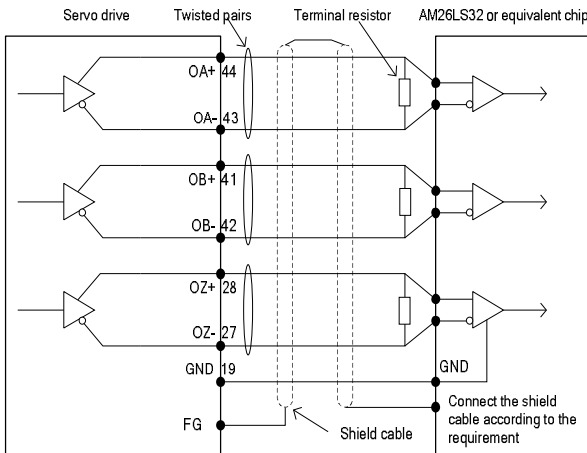

Fig. 4-24 Wiring diagram of the frequency division output circuit of the differential encoder feedback signal

Open-collector mode:

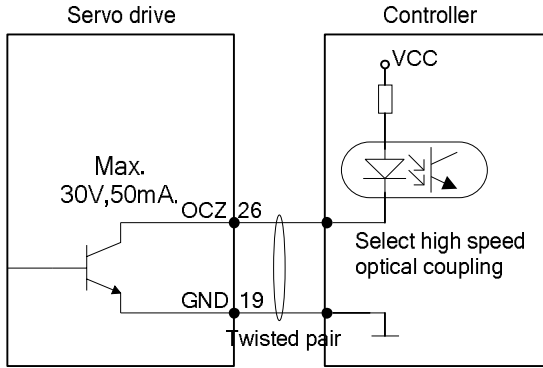

Fig. 4-25 Wiring diagram of the frequency division output circuit of the open-collector encoder feedback signal

- ◆ Phase A and B of the encoder only provides differential output signal, phase Z provides differential output and open-collector output signals.
- ◆ For differential output signal, to use AM26C32 or equivalent differential receiving chip and be sure to fit a terminal matching resistor of about 220Ω is recommended .
- ◆ For the phase Z signal of open-collector output, as the signal pulse width is very narrow, the user shall use high speed optical coupler to receive this signal.
- ◆ Both kinds of output circuits have no isolation.

4.5.6.6 Wiring of the analog output circuit

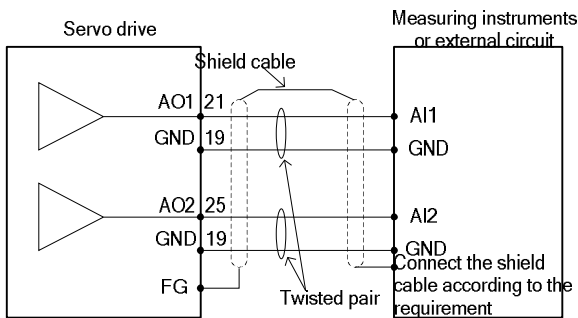

Fig. 4-26 Wiring diagram of the analog output circuit

There are two analog output circuits in all. The output voltage range is 0 – 10V. The Max output current is 3mA.

4.6 Wiring of the electromagnetic brake

In the case the servo motor is used in a vertical shaft, the electromagnetic brake can be used to prevent or keep the falling speed of heavy objects when the servo drive is powered off. The connection of the electromagnetic drive is shown in the figure below:

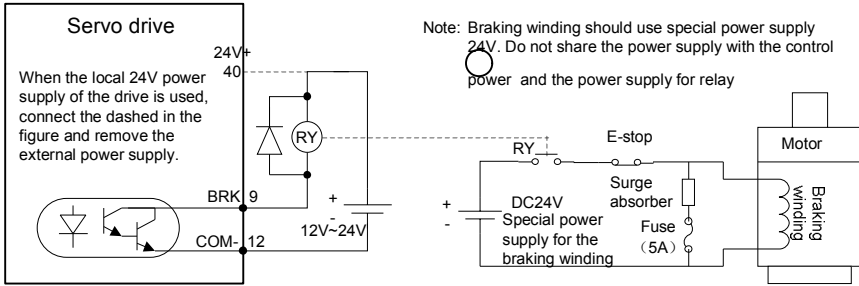

Fig. 4-27 Wiring of the electromagnetic brake

- ◆ The user needs to prepare a special power supply for this electromagnetic brake. Do not share the power supply with the power which is used for control signal;
- ◆ in the figure is the relay coil. Please note the direction of the diode;
- ◆ The electromagnetic brake is used for keeping the speed. It cannot be used for normal stop;
- ◆ Though the electromagnetic brake has the function to prevent or keep the falling speed of heavy objects, the user must install an external braking device at the same time;
- ◆ BRK signal works when the drive stops or fault occurs if the power supply is connected or the servo drive is running. Please refer to chapter 5.1.10 for the sequence.

BRK signal can be closed through the setting of FP3.57. Please refer to FP3.57 for detailed information.

5 Running and operation

5.1 Running

5.1.1 First powering on

Check followings before powering on:

1) Wiring

- ◆ The power supply of the servo drive (R, S, T, r and t) should be connect with proper techniques;
- ◆ The output phase of the servo drive (U, V and W) should be the same as that of the cables of the servo drive;
- ◆ There is no short circuit between the output of the servo drive (U, V and W) and the input power supply (R, S and T);
- ◆ All wiring comply with the standard wiring shown in section 4.5.3~4.5.5;
- ◆ Ensure the external terminal (SON) for servo enabling is set to OFF;
- ◆ Ensure the servo drive and the servo motor are grounded to the earth properly;
- ◆ When using external braking resistor, the short circuit wire between B2-B3 on X2 terminal should be removed;
- ◆ Do not put voltage above DC24V on CN1;
- ◆ The press threshold is among the designated range.。

2) Environment

- ◆ There are no foreign objections, such as metal and other wire lead which can cause short circuit of signal and power wires.

3) Mechanical parts

- ◆ The installation of the servo drive and the connection of the bear are reliable;
- ◆ The servo motor and the machines are available to run;
- ◆ Do not run the motor at negative load (the direction of the output torque of the motor reverses to the speed direction).

If all above items are checked OK, switch on the power supply:

5.1.1.1 Sequence of powering ON/OFF

The control circuit and the main circuit of the drive are supplied separately. In principle, when powering on, switch on the power supply of the control circuit (terminals r, t) first and then switch on the power supply of the main circuit (terminals R, S, T). When powering off, switch off the power supply of the main circuit first and then switch off the power supply of the control circuit.

After switching on the control circuit power supply and before switching on the main circuit

power supply, "AL-PoF" will display on the front panel as the main circuit power-off alarm. it means the bus voltage of the main circuit is 0 or too low.



Warning

After switching on the power supply of the main circuit, do not touch the motor line terminals even if the servo is not started as this may cause electrical shock.

After switching on the power supply, do not touch the electriferous parts as this may cause electric shock.

5.1.1.2 Checking after powering-on

After switching on both of the control circuit and main circuit power supplies, if the power supply is OK, the Power indicator lamp on the front panel will illuminate in red and the servo drive and servo motor will not generate abnormal noise. If there is no fault alarm of the servo drive, the LED on the front panel displays the current speed of the servo motor as default. The default parameter can be set through parameter FP0.15. The 3-color indicator lamp on the front panel illuminates as blue. If there is a fault of the servo drive, the LED displays current alarm sign and the 3-color indicator lamp on the front panel illuminates as red. Please fix the fault by referring to chapter 9.1.

5.1.2 Self-test before running of the servo

The self-test before running the servo is very essential, it includes the following items:

1) Whether there are disconnecting of the motor encoder

Rotate the motor shaft with hands at least one cycle to see if it reports an encoder line break fault (Er-EC1 or Er-EC2).

2) Whether there is abnormality of current detection

Verify whether the motor shaft is rotating while switching on the power, whether it reports a current detection fault (Er-iTE) during power-on.

5.1.3 Parameter setting before running the servo

Parameter setting must be conducted before running the servo. You can set relevant parameters via the front panel or communication to meet the function and performance requirements of the site application. See chapter 5.2.4 for the detailed description of all parameters of the servo drive. Some of these parameters need to be set according to the site application demand. For examples, pulse input mode, electronic gear, frequency division coefficient of encoder output, upper/lower limit of analog input, etc. Some of these parameters need to be set according to the site debugging. For example, the parameters of the regulator loop which affect the system performance and other similar parameters. For most parameters the factory default values are appropriate.

5.1.3 Trial jogging

Trial jogging can check whether the servo drive and the servo motor are intact and conduct preliminary debugging of the system including the servo drive, servo motor and peripheral equipments. Run the servo motor by JOG operation after ensuring that the wiring is correct and there is no fault alarm and no abnormal running, See chapter 5.2.4 for detailed instructions.

Before jog running, ensure:

- ◆ The motor isn't in running state. If the motor is running, JOG operation is invalid;
- ◆ The load inertia shouldn't exceed 15 times of the motor inertia. Otherwise it may cause serious mechanical vibration;
- ◆ The jog speed can be set via parameter FP0.05.
- ◆ The accelerating/decelerating time during jogging can be set via parameters FP0.54, FP0.55 and FP0.56, FP0.57.

5.1.4 Running at the position control mode

Simple connection:

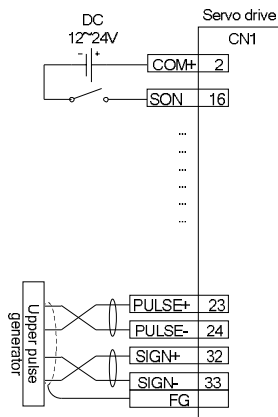

Parameter	Function	Setting value
*FP0.03	Mode selection	0
*FP0.23	Pulse input	Set according to the requirement
*FP0.24	Pulse input direction reverse	0
FP0.25	The first electrical gear numerator	1
FP0.26	The first electrical gear denominator	1

Figure 5-1 Simple connection of the position control mode

Steps:

1. Complete the connection between the drive and the servo motor.
2. Set FP0.03 to "0", the position control mode.
3. Ensure the pulse output of the upper controller and adjust FP0.23. Keep the pulse type is the same as that of the upper controller. Please refer to the instruction of FP0.23.
4. After modifying FP0.03 and FP0.23, it will be valid only when disconnecting the control power and repower on.
5. Connect the corresponding terminal of CN1 and ensure the pulse wires (differential output and open collector output)
6. Connect CN1 to the drive and apply the power supply. Control the connection between SON and COM-. And then, the servo enters into the locking state.
7. Send the low frequency pulse command from the upper controller and rotate the motor at low speed.
8. Ensure the rotating direction of the motor is as the designated. The direction can be modified through the upper controller or operate on FP0.24.
9. Ensure the pulse number is as the designated. Please refer to the instruction of FP0.25 and FP0.26.

5.1.5 Running at the speed control mode

Simple connection

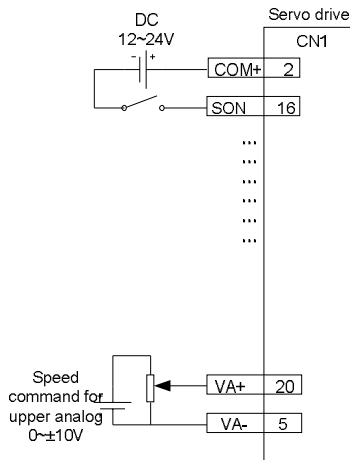

Parameter	Function	Setting value
*FP0.03	Mode selection	1
FP0.40	Speed command selection	1

FP0.42	Speed command input gain	500
FP3.20	Bias voltage of analog input 1	Set according to the requirement

Figure 5-2 Simple connection of the speed control mode

Steps:

1. Complete the connection between the drive and the servo motor.
2. Set FP0.03 to "1", the speed control mode.
3. It is necessary to disconnect the control power supply after saving the modified value of FP0.03. And it will be valid after repowering on.
4. Set FP0.40 to "1", external analog speed command mode.
5. Set FP0.42 to the required value. Please refer to the instruction of FP0.42.
6. Connect the corresponding terminals of CN1.
7. Connect the CN1 to the drive and power on. Control the connection between SON and COM-. Then the servo enters into the locking state.
8. The motor shaft may rotate at a low speed if there is no upper command voltage. It needs to adjust FP3.20. Please refer to the detailed instruction of FP3.20.

5.1.6 Running at the torque control mode

Simple connection:

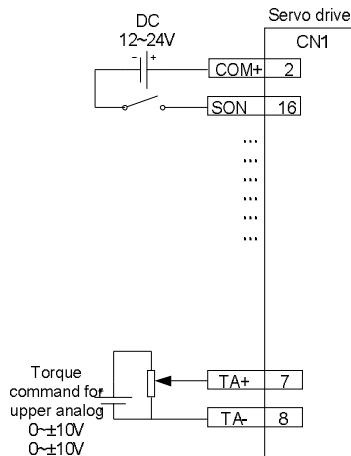

Parameters	Function	Setting value
*FP0.03	Mode selection	2

FP0.60	Torque command selection	1
FP0.62	Torque command input gain	10
FP3.23	Bias voltage of analog input 2	Set according to the requirement
FP0.46	Speed limit 1	100

Figure 5-3 Simple connection of the pulse control mode

Steps:

1. Complete the connection between the drive and the servo motor.
2. Set FP0.03 to "2", the torque control mode.
3. It is necessary to disconnect the control power supply after saving the modified value of FP0.03. And it will be valid after repowering on.
4. Set FP0.04 to "1", external analog torque command mode.
5. Set FP0.62 to the required value. Please refer to the instruction of FP0.62.
6. Connect the corresponding terminals of CN1.
7. Connect the CN1 to the drive and power on. Control the connection between SON and COM-. Then the servo enters into the locking state.
8. The motor shaft may rotate at a low speed if there is no upper command voltage. It needs to adjust FP3.23. Please refer to the detailed instruction of FP3.23.
9. In the torque mode, please adjust the speed limit and set FP0.46 to the required value. Please refer to the detailed instruction of FP0.46.

5.1.7 Parameter setting before running the servo

Parameter setting must be conducted before running the servo. You can set relevant parameters via the front panel or communication to meet the function and performance requirements of the site application. See chapter 6 for the detailed description of all parameters of the servo drive. Some of these parameters need to be set according to the site application demand. For examples, pulse input mode, electronic gear, frequency division coefficient of encoder output, upper/lower limit of analog input, etc. Some of these parameters need to be set according to the site debugging. For example, the parameters of the regulator loop which affect the system performance and other similar parameters. For most parameters the factory default values are appropriate.

Hereunder only some necessary parameters are listed:

1) Mode setting

The control mode (position mode, speed mode, torque mode) can be set through setting parameter FP0.03 according to the control requirements on the site. The mode will be valid after repowering on.

2) Command input

Set or enter relevant commands to control the position, speed or torque of the servo motor's shaft according to the setting of parameter FP0.03.

- ◆ In the position mode: pulse command (3 kinds of input mode), internal torque limit command or external analog torque limit command;
- ◆ In the speed mode: internal speed command or external analog speed command, internal torque limit command or external analog torque limit command;
- ◆ In the torque mode: internal torque command or external analog torque command, internal speed limit command or external analog speed limit command;

5.1.8 Servo enabling



Warning

Do not operate the switches with wet hand as this may cause electric shock.



Note

Please confirm the parameter setting before running. Otherwise unexpected running state of the machinery may occur;

The radiator, regenerative braking resistor, servo motor and other components may become very hot in a period after they are powered on and powered off. Don't touch them!

Enable the servo via the external servo enabling terminal (SON) or internal servo enabling parameter (FP0.04). See the function description of terminal SON and detailed explanation of parameter FP0.04 in chapter 4.5.2.4.

When servo enabling:

- ◆ If no alarm occurs, the state indicator of servo will turn to green;
- ◆ When the dynamic braking is triggering, light clatter can be heard;
- ◆ The fan starts to run;
- ◆ In the position mode, if there is no pulse command input, the servo is in locked state;
- ◆ In the speed mode, the servo motor runs at the given speed;
- ◆ In the torque mode, if no torque is applied externally, the servo motor accelerates from zero speed to the limit speed. If the external torque is larger than the internal setting one, the servo motor maintains the state of zero speed output;
- ◆ If a servo alarm occurs, the servo status indicator will turn to red and the servo motor will get into the inertia running state.

5.1.9 Coast to Stop / DEC to Stop of the servo

If the servo drive is in the following conditions, the servo motor will coast to a stop or stop

normally. Coasting to Stop means the drive cuts off output immediately, the motor coasts to rest under the action of inertia, and does not keep in locked state after that. DEC to Stop means the drive outputs reverse torque to make the motor to decelerate to zero speed and, after that, the motor is in a locked state.

- ◆ When the servo enabling terminal (SON) signal is set to OFF, the servo motor will stop. Select the stopping method through setting parameter FP4.30. See description of FP4.30 for details. This process will not cause regenerative braking.
- ◆ When a fault alarm occurs, the servo motor will stop. Select the stopping method of the servo motor when an alarm occurs through setting parameter FP4.30. See description of FP4.30 for details. This process will not cause regenerative braking.
- ◆ When the zero speed clamp terminal (ZRS) signal is set to ON, the servo motor will stop. In the position mode and torque mode, the servo motor will stop immediately. In the speed mode, set parameter FP0.58 to select whether the servo motor stops immediately or decelerates to stop according to the settings of parameter FP0.56 and FP0.57. After stop the servo is in a locked state. This stop process may cause regenerative braking. If a braking overload fault alarm occurs, please install an external braking resistor.
- ◆ If the travel limit terminal signal is valid (parameter FP3.40=1), and the travel limit terminal (PSL/RVL) signal is set to OFF, the servo motor will immediately decelerate to a stop and get into a locked state. After it stops running, if a reverse running command is valid, the motor can run in reverse direction.

If the emergency stop terminal signal is valid (parameter FP3.41=1), and the emergency stop terminal (EMG) signal is set to OFF, the servo motor will coast to stop.

5.1.10 Sequence diagram

5.1.10.1 Sequence diagram of power-on and servo ON

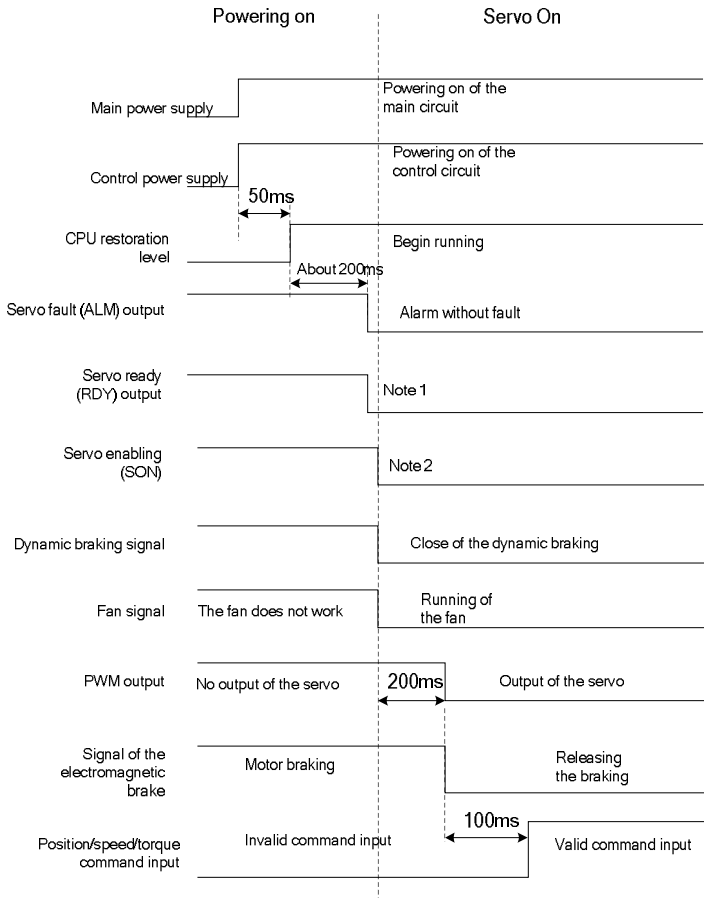

Note 1: the RDY output signal of becomes low when there is no fault to the servo and the bus voltage has been established (the bus voltage is above 220V. If the bus voltage is below 220V, there is AL-PoF alarm);
 Note 2: the servo enabling signal is valid when the the RDY output signal of becomes low.

Fig. 5-4 Sequence diagram of Power-on and servo ON

5.1.10.2 Sequence diagram of power loss during running

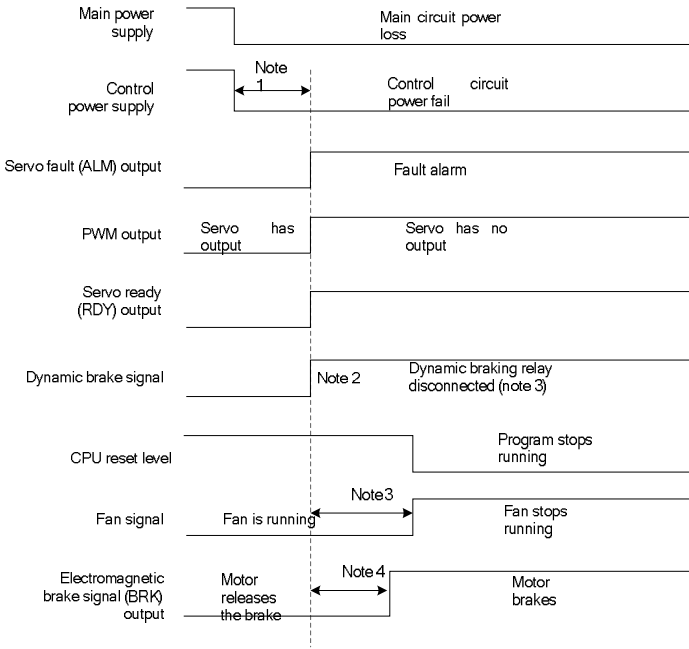

Note 1: When the bus voltage of the control circuit drops below 200V, an undervoltage fault will occur. At this time the servo fault (ALM) output becomes high level;

Note 2: FP4.30 can set the function of immediate disconnection of the dynamic braking relay at undervoltage fault

Note 3: When the module temperature is less than 45℃, the fan will stop. If the module temperature is higher than 45℃, the fan stops running after the CPU reset level becomes lower;

Note 4: The output delay time of the electromagnetic brake signal can be set by the function code FP3.57. At the same time, if the speed drops below 30r/min within the time set of FP3.57, the electromagnetic brake signal (BRK) will also become stronger.

Fig. 5-5 Sequence diagram of power loss during running

5.1.10.3 Servo OFF sequence in a locked state

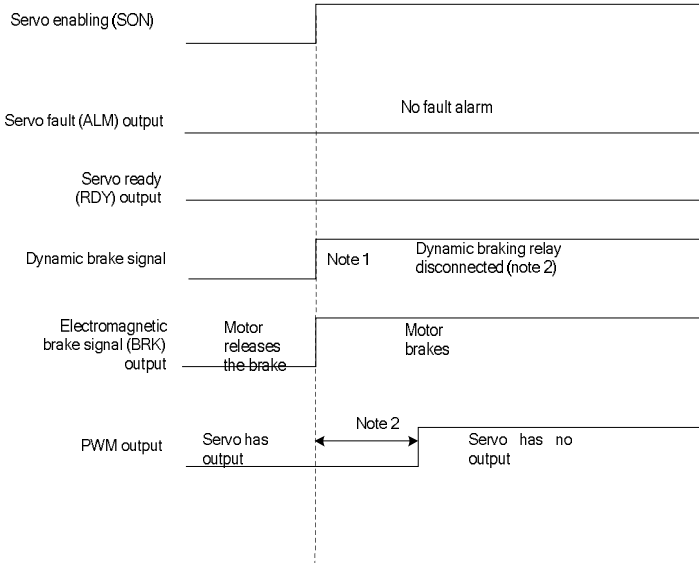

Note 1: FP4.30 can set the function of immediate disconnection of the dynamic braking relay at undervoltage fault

Note 2: The motor power-off delay time can be set by function code FP3.56.

Fig. 5-6 Servo OFF sequence diagram in a locked state

5.1.10.4 Servo OFF sequence in running state

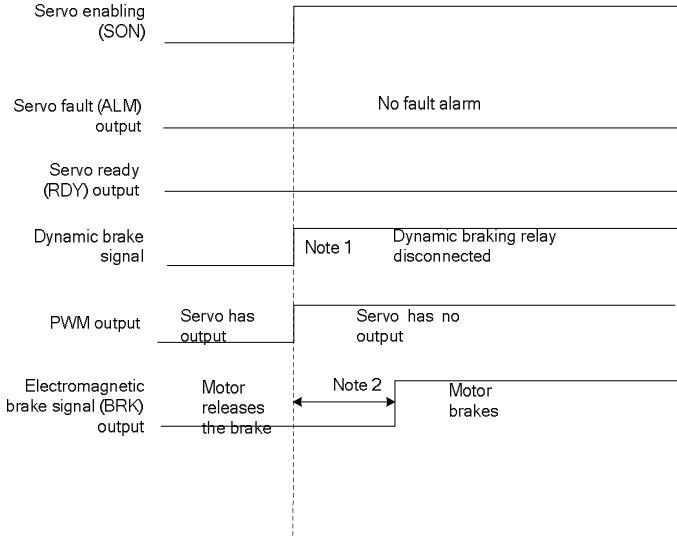

Note 1: FP4.30 can set the function of immediate disconnection of the dynamic braking relay at undervoltage fault

Note 2: The output delay time of the electromagnetic brake signal can be set by function code FP3.57. At the same if the speed drops below 30r/min within the time set of FP3.57, the electromagnetic brake signal (BRK) will also become stronger

Fig. 5-7 Servo OFF sequence diagram in running state

5.1.10.5 Sequence of fault alarm

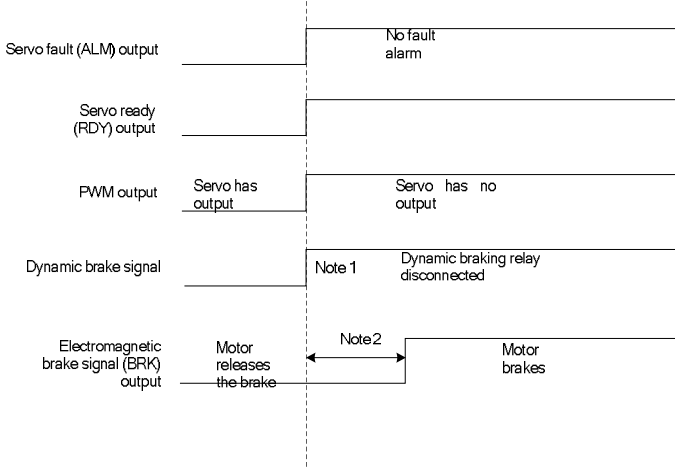

Note 1: FP4.30 can set the function of immediate disconnection of the dynamic braking relay at undervoltage fault

Note 2: The output delay time of the electromagnetic brake signal can be set by function code FP3.57. At the same, if the speed drops below 30r/min within the time set of FP3.57, the electromagnetic brake signal (BRK) will also become stronger.

Fig. 5-8 Sequence diagram of fault alarm

5.2 Display and operation

5.2.1 Display

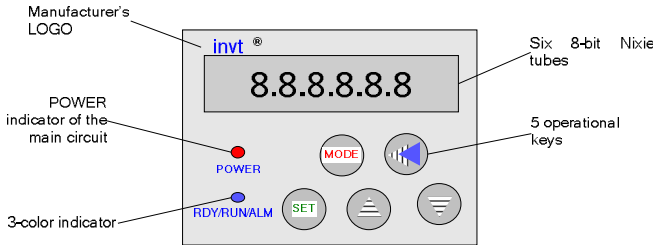

Fig 5-8 Schematic diagram of the keypad

Table 5-1 State of the 3-color indicator

Color	Function
Green	Normal running state
Red	Fault alarm state
Blue	The control board is powering on but the servo is not started

Table 5-2 Key function definition

Key	Key name	Function
	MODE key	Used to switch between different modes or return to previous menu
	SET key	Used to enter next menu or execute setting command
	UP key	Used to select parameter upwards or increase value
	DOWN key	Used to select parameter downwards or decrease value
	SHIFT key	When setting a parameter, it is used to select the position of the current digit

There are 5 operation modes in total, which can be switched with key.

- Status monitoring mode: used to display the values of the status parameters;
- Basic parameter setting mode: used to set the basic parameters;
- Gain and filtering parameter setting mode: used to set gain or filtering parameters;
- Expansion parameter setting mode: used to set the expansion parameters;
- Auxiliary function mode: used for JOG control and to restore parameters to default value.

Operation flowchart:

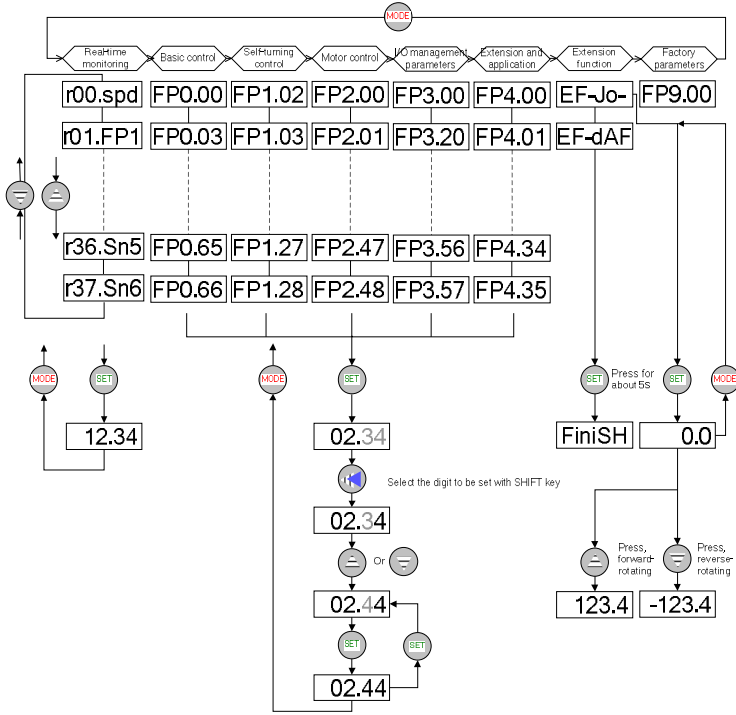

Fig.5-9 Flow chart of front panel operation

5.2.2 State monitoring mode

5.2.2.1 Operation flowchart

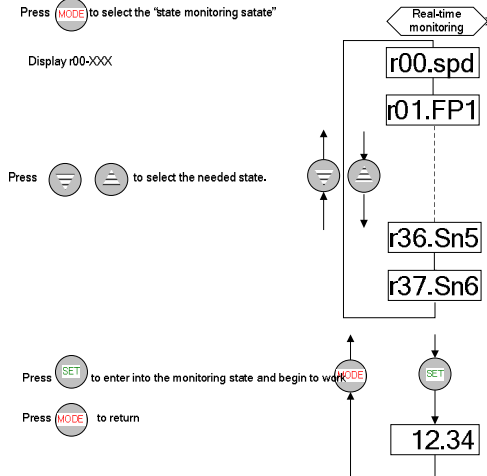

Fig.5-10 Flow chart of state monitoring operation

5.2.2.2 The meaning of state sign

The meanings are shown as below:

Table 5-3 Function meaning

Sign	Name	Unit	Accuracy
r00.spd	Motor speed	r/min	0.1
r01.FP1	Lower 5 digits of feedback pulse accumulation	pulse	1
r02.FP2	Medium 5 digits of feedback pulse accumulation	pulse	1
r03.FP3	Higher 5 digits of feedback pulse accumulation	pulse	1
r04.rp1	Lower 5 digits of command pulse accumulation	pulse	1
r05.rp2	Medium 5 digits of command pulse accumulation	pulse	1
r06.rp3	Higher 5 digits of command pulse accumulation	pulse	1
r07.EP	Detention pulse	pluse	1
r08.An1	Analog speed command voltage	V	0.01
r09.An2	Analog torque command voltage	V	0.01
r10.ud1	Bus voltage of main circuit power	V	0.1
r11.ud2	Bus voltage of control circuit power	V	0.1
r12.cur	RMS value of current output current	A	0.01
r13.Tq	Current torque	%	1
r14.Tn	Module temperature	°C	0.1
r15.Ld	Ratio of average load	%	1
r16.PoS	Position of the rotor relative to Z pulse	pulse	1
r17.inE	Ratio of load inertia	time	1
r18.oAL	Third latest fault alarm code	-	-
r19.AL	Second latest fault alarm code	-	-
r20.ALc	Latest fault alarm code	-	-
r21.in	Digital input state	-	-
r22.ou	Digital output state	-	-
r23.TT	Motor temperature	-	-
r24.uE1	DSP software version	-	-

Sign	Name	Unit	Accuracy
r25.uE2	FPGA software version	-	-
r26.uuu	Encoder feedback value	-	-
r27.iA	Instantaneous value of U phase output current	A	0.01
r28.ib	Instantaneous value of V phase output current	A	0.01
r29.iAF	Instantaneous value of U phase output current when a fault occurs	A	0.01
r30.ibF	Instantaneous value of phase V output current when a fault occurs	A	0.01
r31.udF	Bus voltage when a fault occurs	V	0.1
r32.Sn1	Drive serial No. 1	-	-
r33.Sn2	Drive serial No. 2	-	-
r34.Sn3	Drive serial No. 3	-	-
r35.Sn4	Drive serial No. 4	-	-
r36.Sn5	Drive serial No. 5	-	-
r37.Sn6	Drive serial No. 6	-	-

5.2.3 Parameter setting

5.2.3.1 Operation flowchart

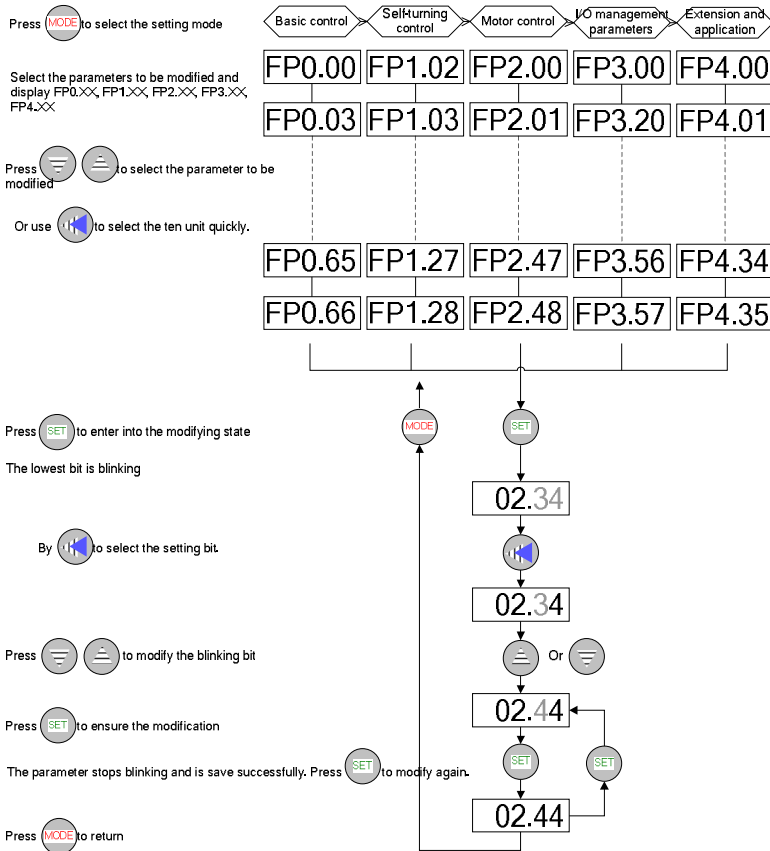

Fig.5-11 Flow chart of parameter setting operation

5.2.3.2 Parameters list

P – position mode; S – speed mode; T – torque mode.

The function codes prefixed with sign “*” indicate the setting of these parameters can only take effect after the system resets, restarts, or control circuit is powered off and repowered.

Function code	Name	Unit	Range	Default	Mode
FP0 Basic control					
FP0.00	Matching motor selection	-	200~599	-	PST
FP0.03*	Mode selection	-	0~6	0	PST
FP0.04	Internal servo enabling	-	0~1	0	PST
FP0.05	Jog speed	r/min	0.0~1000.0	200.0	PST
FP0.06*	Numerator of the frequency division coefficient of encoder pulse output	-	0~30000	10000	PST
FP0.07*	Denominator of the frequency division coefficient of encoder pulse output	-	0~30000	0	PST
FP0.11	Max torque limit	%	0.0~300.0	300.0	PST
FP0.12	Internal torque limit	%	0.0~300.0	-	PS
FP0.13	Power of the external braking resistor	W	0~1500	0	PST
FP0.14	Resistance of the external braking resistor	Ω	1~100	1	PST
FP0.15*	Default monitoring parameters	-	0~37	0	PST
FP0.16	Parameter modification operation locking	-	0~1	0	PST
FP0.17	Communication EEPROM write selection	-	0~1	0	PST
FP0.23*	Pulse input	-	0~2	0	P
FP0.24*	Pulse input direction reversing	-	0~1	0	P
FP0.25	Numerator of the 1 st electronic gear	-	1~65535	1	P
FP0.26	Denominator of the 1 st electronic gear	-	1~65535	1	P
FP0.27	Numerator of the 2 nd electronic gear	-	1~65535	1	P
FP0.28	Numerator of the 3 rd electronic gear	-	1~65535	1	P
FP0.29	Numerator of the 4 th electronic gear	-	1~65535	1	P
FP0.30	Denominator of the 2 nd electronic gear	-	1~65535	1	P
FP0.31	Denominator of the 3 rd electronic gear	-	1~65535	1	P

Function code	Name	Unit	Range	Default	Mode
	electronic gear				
FP0.32	Denominator of the 4 th electronic gear	-	1~65535	1	P
FP0.33	Position command filter time	ms	0.0~1000.0	0.0	P
FP0.40	Speed command/speed limit selection	-	0~1	0	ST
FP0.42	Speed command input gain	(r/min)/ v	10~1000	500	ST
FP0.44	Speed command filter time	ms	0.0~1000.0	0.0	S
FP0.45	Dead zone of analog VA	V	0.000~2.000	0.000	ST
FP0.46	Internal speed/speed limit 1	r/min	-6000.0~600 0.0	100.0	ST
FP0.47	Internal speed/speed limit 2	r/min	-6000.0~600 0.0	200.0	ST
FP0.48	Internal speed/speed limit 3	r/min	-6000.0~600 0.0	500.0	ST
FP0.49	Internal speed/speed limit 4	r/min	-6000.0~600 0.0	1000.0	ST
FP0.54	ACC time	ms	0~20000	0	S
FP0.55	DEC time	ms	0~20000	0	S
FP0.56	S curve ACC time	ms	0~1000	0	S
FP0.57	S curve DEC time	ms	0~1000	0	S
FP0.58	Stopping method	-	0~1	0	S
FP0.60	Torque command/torque limit selection	-	0~1	0	PST
FP0.62	Torque command input gain	%/V	10~300	10	PST
FP0.64	Torque command filter time	ms	0.0~1000.0	0.0	T
FP0.65	Dead zone of analog TA	V	0.000~2.000	0.000	PST
FP0.66	Internal torque command	%	-250.0~250.0	10.0	T
FP1 Self-turning control					
FP1.02	Rotational inertia ratio	%	0~10000	200	PST
FP1.03	Machine rigidity setting	-	0~31	13	PST
FP1.04	Inertia identification switch	-	0~1	0	P
FP1.05	Inertia identification operation	-	0~3	0	P
FP1.06	Mechanical movement	r	0.5~10.0	1.5	P
FP1.07	Identification of inertia acceleration time constan	ms	2~200	2	P
FP1.20	Resonance frequency test valid	-	0~1	0	PST

Function code	Name	Unit	Range	Default	Mode
FP1.21	1 st mechanical resonance frequency	Hz	0.0~3000.0	0.0	PST
FP1.22	2 nd mechanical resonance frequency	Hz	0.0~3000.0	0.0	PST
FP1.23	1 st trap wave center frequency	Hz	50.0~3000.0	3000.0	PST
FP1.24	1 st trap wave width	Hz	1.0~1000.0	50.0	PST
FP1.25	1 st trap wave depth	%	0.00~1.00	0.00	PST
FP1.26	2 nd trap wave center frequency	Hz	50.0~3000.0	3000.0	PST
FP1.27	2 nd trap wave width	Hz	1.0~1000.0	50.0	PST
FP1.28	2 nd trap wave depth	%	0.00~1.00	0.00	PST
FP2 Motor control					
FP2.00	1 st speed gain	Hz	0.1~3000.0	27.0	PST
FP2.01	1 st speed integration time constant	ms	0.1~1000.0	21.0	PST
FP2.02	1 st position gain	1/s	0.1~3000.0	48.0	P
FP2.03	1 st speed detection filter time	ms	0.00~100.00	0.00	PST
FP2.04	1 st torque filter	ms	0.00~25.00	0.84	PST
FP2.05	2 nd speed gain	Hz	0.1~3000.0	27.0	PST
FP2.06	2 nd speed integration time constant	ms	0.1~1000.0	1000.0	PST
FP2.07	2 nd position gain	1/s	0.1~3000.0	57.0	P
FP2.08	2 nd speed detection filter time	ms	0.00~100.00	0.05	PST
FP2.09	2 nd torque filter	ms	0.00~25.00	0.84	PST
FP2.10	Speed feed-forward	%	0.0~100.0	30.0	P
FP2.11	Speed feed-forward filter time	ms	0.00~60.00	0.50	P
FP2.12	Torque feed-forward gain	%	0.0~100.0	0.0	PS
FP2.21	Gain switching selection	-	0~1	1	PST
FP2.22	Gain switching condition	-	0~5	0	PS
FP2.23	Gain switching time constant	ms	0~100	0	PS
FP2.25	Gain switching threshold	Pulse or r/min	0~5000/0~50 0.0	100/10.0	PS
FP2.47	Speed compensation threshold	pulse	0~20000	100	P
FP2.48	Speed compensation	r/min	0~500.0	0.0	P
FP3 I/O management					
FP3.00	Digital 1 input	-	0~11111	0	PST
FP3.20	Offset of AI VA	V	-2.000~2.000	0.000	ST
FP3.23	Offset of AI TA	V	-2.000~2.000	0.000	PST

Function code	Name	Unit	Range	Default	Mode
FP3.30	AO 1 selection	-	0~7	0	PST
FP3.31	Voltage gain of analog output 1	-	0~1000	500	PST
FP3.32	AO 2 selection	-	0~7	0	PST
FP3.33	Voltage gain of analog output 2	-	0~1000	500	PST
FP3.34	Offset of AO1	V	-2.00~2.00	0.00	PST
FP3.35	Offset of AO 2	V	-2.00~2.00	0.00	PST
FP3.40	Travel limit switch masking	-	0~1	0	PST
FP3.41	E-stop masking	-	0~1	0	PST
FP3.50	Range of position reaching	pulse	0~20000	100	P
FP3.54	Range of speed reaching	r/min	0.0~1000.0	30.0	S
FP3.55	Zero speed range	r/min	0.0~1000.0	50.0	PST
FP3.56	Locked time of servo after braking	ms	100~5000	100	PST
FP3.57	Braking delay time of the electromagnetic brake	ms	0~5000	1000	PST
FP4 Extension and application					
FP4.00*	Communication mode	-	0~1	1	PST
FP4.01	Local communication address	-	0~31	1	PST
FP4.02*	Communication baudrate selection	-	0~4	0	PST
FP4.04	Communication parity mode	-	0~17	0	PST
FP4.05	Communication response delay time	ms	0~200	0	PST
FP4.06	Communication overtime fault time	s	0.0~60.0	0.0	PST
FP4.07	Communication fault processing method	-	0~1	0	PST
FP4.08	Communication response enabling	-	0~1	1	PST
FP4.09	Reserved	-	-	-	PST
FP4.30	Stopping mode selection	-	0~4	3	PST
FP4.31	Max. speed limit	r/min	0~6500.0	-	PST
FP4.32	Overspeed level	r/min	0~6553.5	-	PST
FP4.33	Pulse range for over position	10puls e	0~50000	2000	P
FP4.34	Brake overload detection enabling signal	-	0~1	1	PST
FP4.35	Input phase loss setting	-	0~1	0	PST

Function code	Name	Unit	Range	Default	Mode
FP9 Factory parameters					
FP9.00	Factory password			100	PST

5.2.4 Auxiliary functions

There are two auxiliary functions: 1. Jogging trial function **EF-Jo-**

2. Function of parameters restoration **EF-dAF**

These functions can be selected by pressing  or .

5.2.4.1 Operation flowchart for jogging trial

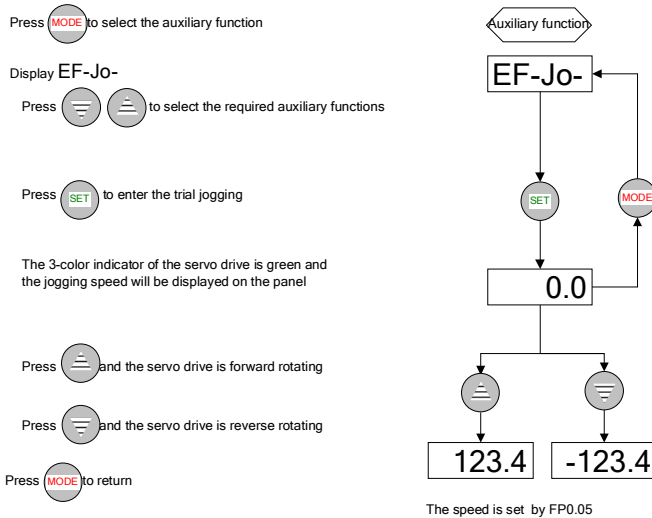

Fig.5-12 Flow chart of jogging trial operation

5.2.4.2 Operation flowchart for function parameters restoration

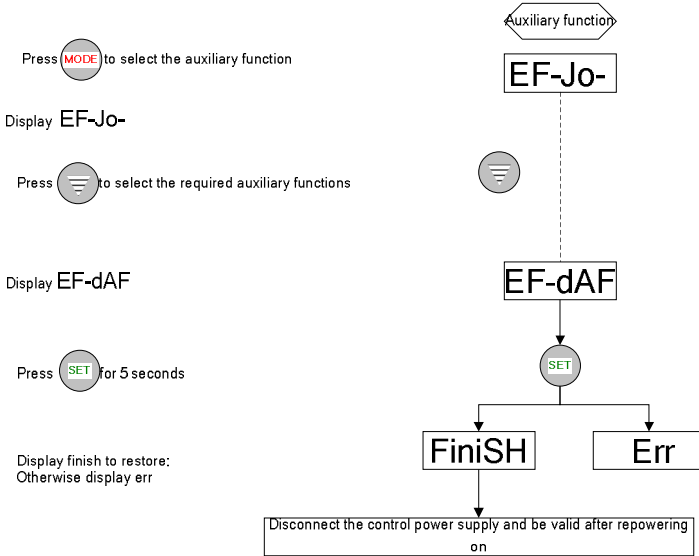

Fig.5-10 Flow chart of default parameter function restoration operation

5.2.5 Alarm display

When the servo drive runs abnormally, it will perform fault alarm or warning protection. At this time the panel will display the fault alarm or warning identifier.

The meanings of the alarm or warning identifiers are listed in the table below:

Table 5-4 Comparison table of faults or warning identifier

Sign	Name
er-EEP	EEPROM fault
er-ec1	Encoder line break fault 1
er-ec2	Encoder line break fault 2
er-ite	Current test fault
er-oc1	Hardware overcurrent fault
er-oc2	Line-to-ground short circuit fault
er-bce	Brake overload fault
er-ou	Overvoltage fault
er-uu	Undervoltage fault
er-ol	Overload fault
er-lne	Ground abnormality fault
er-os	Overspeed fault

Sign	Name
er-oh1	Drive overtemperature fault
er-uu1	Software overcurrent fault
er-oe	Over-pulse fault
er-ct e	Communication fault
er-ot	Write/read overtime fault
er-bcE	Brake overload fault
er-i po	IPM module fault
er-dp	The power input phase loss fault
er-inE	Inertia identification fault
Er-DrE	Motor parameters matching fault
al-lt1	Forward travel limit warning
al-lt2	Reverse travel limit warning
al-est	Emergency stop warning
al-pof	Main circuit power-down warning
al-ct e	Communication abnormality warning

5.2.6 Alarm clearance

For fault alarms, if the fault condition is removed, the fault alarm display can be removed by short connecting the alarm clear terminal CLA with COM-. If the servo is still in enabled state at this time, the drive will recover running automatically. Please note that when EC2 fault or OC2 fault is reported, even if the fault is removed, it can be cleared only after the control circuit is powered off and re-on. For warnings, if it is the travel limit warning, once the warning condition is removed, the drive will clear the warning display automatically. If the servo is still in enabled state at this time, the drive will recover running automatically. If it is the emergency stop warning, if the warning condition is removed, the warning display can be removed by short connecting the alarm clear terminal CLA with COM-. But the servo must be enabled again to allow the drive to continue running.

If parameters need to be set when a fault alarm or warning occurs but they are not removed,

press and hold  for about 3 seconds while the panel displays the fault alarm or warning identifier to enter the parameter setting mode. After the parameters are set, press and hold

down  for about 3 seconds to exit the parameter setting mode and the panel recovers displaying of the fault alarm or warning identifier.

6 Detailed parameter description

Sign description: P – position mode; S – speed mode; T – torque mode.

The setting of the parameters marked with * can only take effect when the control circuit is powered-off and re-power-on.

6.1 Basic parameters (FP0 group parameters)

6.1.1 Basic control

FP0.00	Matching motor selection	Setting range	Default	Unit	Available mode		
		200~500	-	-	P	S	T

Detailed instruction: Right motor parameters are set in factory. Refer to the name plate. For example, the name plate of 400W motor is :

of which, No.: 2300 is the set value of the parameter.

Note: Wrong setting may cause abnormal running or damage to the drive and motor.

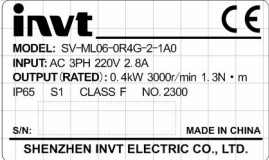

*FP0.03	Mode selection	Setting range	Default	Unit	Available mode		
		0~6	0	-	P	S	T

Detailed instruction:

This parameter can be used to set the operating mode of the system:

Setting value	1 st working mode	2 nd working mode	Instruction
0	P	/	Position mode: In the position mode, it can control the angular displacement of the servo motor with the pulse command and thus achieve the goal to control the displacement of the mechanical movement.
1	S	/	Speed mode: The mode can control the rotation speed of the servo motor with the internal speed command or external analog speed command
2	T	/	Torque mode: The mode can control the output torque of the servo motor with the

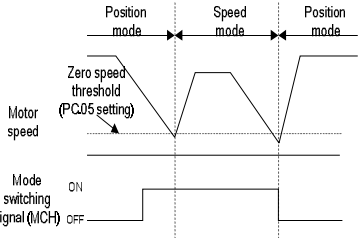
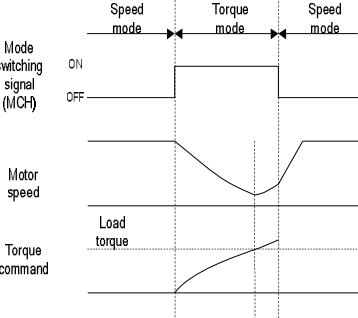
			<p>internal torque command or external analog torque command.</p>
<p>3</p>	<p>P</p>	<p>S</p>	<p>Position/speed mode: The position mode and speed mode can be switched with the control mode switching terminal (MCH pin "1").</p>  <p>Note: For safety, after changing the MCH terminal input status, the switching between position mode and speed mode can be performed only when the motor speed becomes lower than the value of zero speed range (FP3.55).</p>
<p>4</p>	<p>S</p>	<p>T</p>	<p>Speed/torque mode: The speed mode and torque mode can be switched with control mode switching terminal (MCH pin "1").</p>  <p>Note: The mode can not be limited by the current working condition.</p>

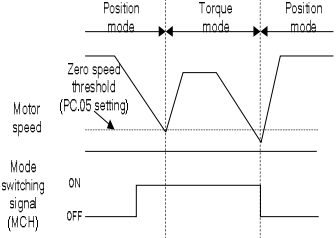
5	P	T	<p>Position/torque mode: The position mode and torque mode can be switched with the control mode switching terminal (MCH pin "1").</p>  <p>Note: For safety, after changing the MCH terminal input status, the switching between position mode and torque mode can be performed only when the motor speed becomes lower than the value of zero speed range (FP3.55).</p>
6	Reserved	Reserved	<p>Factory reserved mode. Setting by the user is prohibited.</p>

Remarks:

MCH terminal state	Current working mode
0	1 st working mode
1	2 nd working mode

Note: MCH is the connecting terminal of CN1. The corresponding relationships between pin "1" and COM-:

0: OFF (the terminal is disconnected with COM-);

1: ON (the terminal is connected with COM-).

FP0.04	Internal enabling command	Setting range	Default	Unit	Available mode		
		0~1	0	-	P	S	T

Detailed instruction:

Control the running state through modifying the parameters:

Setting value of FP0.04	External terminal command state	Working state of the servo drive
0	0(the terminal is	Stand-by (OFF)

		disconnected with COM-)	
0		1(the terminal is connected with COM-)	Enabling running (ON)
1		0(the terminal is disconnected with COM-)	Enabling running (ON)
1		1(the terminal is connected with COM-)	Enabling running (ON)

Note: For safety, this parameter will automatically become 0 when fault alarm occurs and after the control circuit is powered on and the system is reset. If you want to run the servo drive, this parameter must be reset.

Warning: If the servo drive is controlled by the external, please ensure there is no system fault and disconnect the terminal with COM-.

FP0.05	Jog speed (JOG)	Setting range	Default	Unit	Available mode		
		0~1000.0	200.0	r/min	P	S	T

Detailed instruction:

This parameter can be used to set the jog speed. For jogging, please refer to chapter 5.1.3. During jogging, the ACC/DEC time parameters (FP0.54, FP0.56, FP0.55, FP0.57) are active. The motor will accelerate, decelerate, start and stop according to the settings.

*FP0.06	Numerator of the frequency division coefficient of encoder pulse output	Setting range	Default	Unit	Available mode		
		0~10000	1	1	P	S	T
*FP0.07	Denominator of the frequency division coefficient of encoder pulse output	Setting range	Default	Unit	Available mode		
		0~10000	1	1	P	S	T

Detailed instruction:

By setting the numerator and denominator of the frequency division coefficient of encoder pulse output, the phase A and phase B signals of the encoder can be frequency divided by any integer or decimal fraction and then outputted through the encoder's pulse output signal terminals(OA+, OA-, OB+ and OB- pin 44, 43, 41 and 42) FP0.06

$$\text{Output pulse number of the drive} = \frac{\text{Resolution of the encoder}}{\text{Resolution of the encoder}}$$

FP0.07

Note: In the position control mode, if the encoder output signal of the preceding stage servo motor is used as the position pulse command input of the succeeding stage servo drive, i.e. as start/stop type master-slave follow-up, in order to ensure high positioning accuracy of the succeeding stage servo drive, the frequency division coefficient must be 1:1. Otherwise the accuracy of master-slave position follow-up will be affected in this case.

FP0.11	Max torque limit	Setting range	Default	Unit	Available mode		
		0~300	300	%	P	S	T

Detailed instruction:

This parameter can be used to set the maximum torque of the servo motor can output. Taking the rated torque of the servo motor as 100%, the setting is the percentage of the rated torque of the servo motor. If the absolute value of the torque command is larger than the value of this parameter, then the actual output torque will be limited by the parameter.

FP0.12	Internal torque limit	Setting range	Default	Unit	Available mode		
		0~300.0	250.0	%	P	S	

Detailed instruction:

In the speed and position modes, this parameter is used to set the value of internal torque limit. Taking the rated torque of the servo motor as 100%, this setting is the percentage of the rated torque of the servo motor.

Control mode	Setting value of FP0.04	TQC	Torque limit state
Position mode or speed mode	0	0	Setting value of FP0.12 internal torque limit
		1	External analog torque limit
	1	Invalid	External analog torque limit

Note:

1. Below is the relationship between TQC and COM-:

0: OFF (the terminal is disconnected with COM-);

1: ON (the terminal is connected with COM-).

2. The default value and setting range of the parameter are relative to the power grade of the drive. The default value of drives below 2.0kW (including 2.0kW) 2.0kW is 0~300.0 and the default value of drives above (including) 2.0kW is 0~250.0.

FP0.14	Resistance of the external braking resistor	Setting range	Default	Unit	Available mode		
		1~100	1	Ω	P	S	T
FP0.13	Power of the external braking resistor	Setting range	Default	Unit	Available mode		
		0~1500	0	W	P	S	T

Detailed instruction:

When an external braking resistor is connected, this group of parameters should be set with the values equal to the resistance and power of the external braking resistor. Please set this group of parameters correctly. Otherwise if the values of this group of parameters are not matched with the parameters of the external braking resistor, it may report a braking overload fault (Er-bCE) by mistake or cause burnout of the braking resistor. The regenerative braking overload protection time is proportional to these two parameters. When FP0.13=0, the internal braking resistor is active.

*FP0.15	Default monitored parameters	Setting range	Default	Unit	Available mode		
		0~26	0	-	P	S	T

Detailed instruction:

This parameter is used to set the parameters which can be monitored while powering-on of the system:

Setting value	Parameter meaning	Accuracy	Unit
00	Current motor rotation speed	0.1	r/min
01	Lower 5 digits of feedback pulse accumulation	1	pulse
02	Medium 5 digits of feedback pulse accumulation	1	pulse
03	Higher 5 digits of feedback pulse accumulation	1	pulse
04	Lower 5 digits of command pulse accumulation	1	pulse
05	Medium 5 digits of command pulse accumulation	1	pulse
06	Higher 5 digits of command pulse accumulation	1	pulse

07	Retention pulse	1	pulse
08	Analog speed command voltage	0.01	V
09	Analog torque command voltage	0.01	V
Setting value	Parameter meaning	Accuracy	Unit
10	Main circuit power bus voltage	0.1	V
11	Control circuit power bus voltage	0.1	V
12	Effective value of current output current	0.01	A
13	Current torque	1	%
14	Drive module temperature	0.1	°C
15	Average load rate	1	%
16	Position of the rotor relative to Z pulse	1	pulse
17	Inertia ratio of load	1	time
18	The two previous fault alarm code	/	/
19	The previous fault alarm code	/	/
20	Current fault alarm code	/	/
21	Digital input state	/	/
22	Digital output state	/	/
23	Motor temperature	0.1	°C
24	DPS software version	/	/
25	FPGA software version	/	/
26	Encoder UVW feedback value	/	/
27	Instantaneous value of phase U output current	0.01	A
28	Instantaneous value of phase V output current	0.01	A

29	Instantaneous value of U phase output current when a fault occurs	0.01	A
30	Instantaneous value of phase V output current when a fault occurs	0.01	A
31	Bus voltage when a fault occurs	0.1	V
32	Drive serial No. 1	/	/
33	Drive serial No. 2	/	/
34	Drive serial No. 3	/	/
35	Drive serial No. 4	/	/
36	Drive serial No. 5	/	/
37	Drive serial No. 6	/	/

FP0.16	Parameter modification operation locking	Setting range	Default	Unit	Available mode		
		0~1	0	-	P	S	T
Detailed instruction:							
This parameter is used to mask the parameter setting function and thus to avoid incorrect modification of the parameters by the user:							
	Setting value	Operation	Communication operation				
	0	Parameter modification valid	Parameter modification valid				
	1	Parameter modification invalid	Parameter modification valid				

6.1.2 Position control

*FP0.23	Pulse input form	Setting range	Default	Unit	Available mode		
		0~2	0	-	P	-	-
Detailed instruction:							
This parameter is used to set the manner of pulse input. There are 3 types of pulse input manners:							
FP0.23	Pulse input form	Signal form	Shown in the picture				
			FWD(CW)		REV(CCW)		

0	Pulse + sign	pulse sign		
1	FWD/REV pulse train	pulse sign		
2	Orthogonal encoder pulse	pulse sign		

Remark: The pulse direction of the parameter can be reversed by FP0.24. Please refer to FP0.24 for detailed information.

*FP0.24	Pulse input direction reversing	Setting range	Default	Unit	Available mode		
		0~1	0	-	P	-	-

Detailed instruction:
 By setting this parameter, the direction of the input pulse can be reversed. At this time the actual output speed direction of the servo drive is opposite to the direction indicated by the pulse input form in FP0.23.
 0: Pulse input direction does not change;
 1: Pulse input direction is opposite to the original input direction.

Parameter	Description	Setting range	Default	Unit	Available mode		
FP0.25	Numerator of the 1 st electronic gear	1~65535	1	-	P	-	-
FP0.26	Denominator of the 1 st electronic gear	1~65535	1	-	P	-	-
FP0.27	Numerator of the 2 nd electronic gear	1~65535	1	-	P	-	-
FP0.28	Numerator of the 3 rd electronic gear	1~65535	1	-	P	-	-
FP0.29	Numerator of the 4 th electronic gear	1~65535	1	-	P	-	-

	FP0.30	Denominator of the 2 nd electronic gear	Setting range	Default	Unit	Available mode		
			1~65535	1	-	P	-	-
	FP0.31	Denominator of the 3 rd electronic gear	Setting range	Default	Unit	Available mode		
			1~65535	1	-	P	-	-
	FP0.32	Denominator of the 4 th electronic gear	Setting range	Default	Unit	Available mode		
			1~65535	1	-	P	-	-

Detailed instruction:

Concept of the electronic gears: for discretionary pulse input, the number and frequency of the pulse actually received by the drive can be changed by multiplying a certain coefficient. It can be shown separately with two parts: numerator and denominator:

$$\text{Electronic gear} = \frac{g_1}{g_2 \cdot 2} ;$$

Of which

g_1 :The numerator of the electronic gear;

g_2 : The denominator of the electronic gear;

Below is the schematic diagram of the electronic gear in the system:

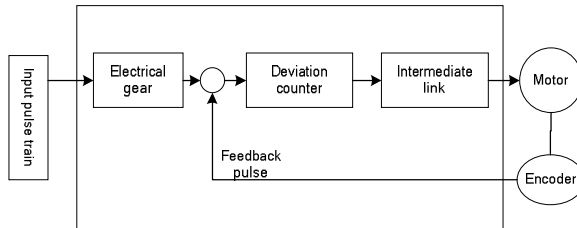

Example:

Below is a case where 1 pulse is equivalent to a feed rate of 10 μm

Mechanical specifications:

Feed of the ball screw $P_b = 10\text{mm}$;

Reduction ratio $n = 3/5$;

Resolution of the servo motor encoder =10000;

At this time calculate the electronic gear:

$$\frac{g_1}{g_2} = \Delta l_0 \cdot \frac{P_t}{\Delta S} = \Delta l_0 \cdot \frac{P_t}{n \cdot P_b} = 10 \times 10^{-3} \cdot \frac{10000}{(3/5) \cdot 10} = \frac{50}{3}$$

In the formula :

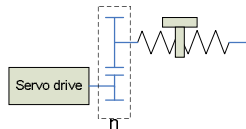

Δl_0 : Feed rate corresponding to per pulse (mm/pulse);

ΔS : Feed rate corresponding to per revolution of the motor (mm/rev).

i.e. in this example, $g1=50$, $g2=3$.

Set FP0.25 to 50 and FP0.26 to 3.

The servo drive supplied 4 groups of electronic gear: FP0.25, FP0.26, FP0.27, FP0.30, FP0.28, FP0.31, FP0.29 and FP0.32. Select the terminal by the electronic gear of CN1 (Pin 34 of SC1 and Pin 17 of SC2) to determine the parameter. The corresponding relationships are listed in the table below:

SC1	SC2	Position mode
0	0	Electronic gear 1
1	0	Electronic gear 2
0	1	Electronic gear 3
1	1	Electronic gear 4

Note: SC1 and SC2 are the wiring terminals of CN1. The relationship between COM- and Pin 34 and 17:

0: OFF (the terminal is disconnected with COM-);

1: ON (the terminal is connected with COM-).

FP0.33	Position command filter time	Setting range	Default	Unit	Available mode		
		0~6000	0	512 μ s	P	-	-

Detailed instruction:

This parameter is used to set the time constant of the 1st order low-pass filter corresponding to the position command. By setting this parameter, mechanical shock can be reduced in cases when the input pulse command frequency changes abruptly.

See the figure below:

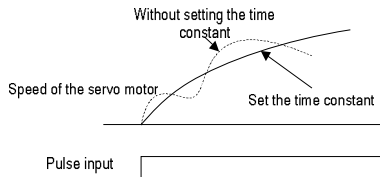

6.1.3 Speed and torque control

FP0.40	Speed command selection/speed limit selection	Setting range	Default	Unit	Available mode		
		0~1	0	-	-	S	T

Detailed instruction:																				
Control mode	Function name	Setting value of FP0.40	Input method	Instruction																
Speed mode	Speed command selection	0	Internal speed command manner	Select the internal multi-stage speed by the speed selection terminal of CN1(Pin 34 and 17 of SC1 and SC2)																
				<table border="1"> <thead> <tr> <th>SC2</th> <th>SC1</th> <th>Parameter</th> <th>Speed mode</th> </tr> </thead> <tbody> <tr> <td>0</td> <td>0</td> <td>FP0.46</td> <td>Internal speed 1</td> </tr> <tr> <td>0</td> <td>1</td> <td>FP0.47</td> <td>Internal speed 2</td> </tr> <tr> <td>1</td> <td>0</td> <td>FP0.48</td> <td>Internal speed 3</td> </tr> <tr> <td>1</td> <td>1</td> <td>FP0.49</td> <td>Internal speed 4</td> </tr> </tbody> </table>	SC2	SC1	Parameter	Speed mode	0	0	FP0.46	Internal speed 1	0	1	FP0.47	Internal speed 2	1	0	FP0.48	Internal speed 3
SC2	SC1	Parameter	Speed mode																	
0	0	FP0.46	Internal speed 1																	
0	1	FP0.47	Internal speed 2																	
1	0	FP0.48	Internal speed 3																	
1	1	FP0.49	Internal speed 4																	
				Please refer to the detailed instruction of FP0.46, FP0.47, FP0.48 and FP0.49.																
		1	External analog speed command manner	The speed of the servo motor can be controlled by applying a voltage between -10V and 10V on the analog speed input terminals (VA+, VA- and pin 20 and 5). According to the factory default, positive value means forward direction and negative value means reverse direction. But it can be changed by setting parameters Pc.28~Pc.31. Please refer to the detailed instruction of Pc.28~Pc.31.																
Torque mode	Speed limit selection	0	Internal speed limit	Select the internal multi-stage speed limit by the speed selection terminal of CN1 (SC1, SC2 and pin 34 and 17).																

SC2	SC1	Parameter	Speed mode
0	0	FP0.46	Speed

							limit 1	
				0	1	FP0.47	Speed limit 2	
				1	0	FP0.48	Speed limit 3	
				1	1	FP0.49	Speed limit 4	
				Please refer to the detailed instruction of FP0.46, FP0.47, FP0.48 and FP0.49.				
				Note: The speed limit depends on the absolute value of the corresponding parameter. The direction is the same as that of the torque command.				
		1	External analog speed limit manner	The motor speed can be limited by applying a voltage between -10V and 10V on the analog speed limit terminals (VA+, VA- and pin 20 and 5). The magnitude of the speed limit value is the absolute value of the analog input, the direction of it is the same as that of the torque command. The speed limit can be modified.				
				Note: The speed limit depends on the absolute value of the corresponding parameter. The direction is the same as that of the torque command.				
Note: Please note that in the torque mode; do not allow the motor to run under the condition of negative load.								

FP0.42	Speed command input gain	Setting range	Default	Unit	Available mode	
		10~1000	500	(r/min)/v	-	
Detailed instruction:						
1. The voltage of set analog input VA corresponds to the switching gain of command speed.						
2. The relationship between analog VA input coltage and speed is default as each 1V: 500r/min.						
	FP0.40	Speed command/speed limit				
	0	FP0.46, FP0.47, FP0.48, FP0.49				

1	Input voltage x FP0.42
---	------------------------

Note:

1. Analog input VA is the input signal from analog speed/speed limit terminal.
2. The parameter is valid when FP0.40 is set to "1".
3. Set right parameter after ensure the running. Big setting value may cause big fluctuation of motor speed.
4. Large voltage between VA+ and VA- may cause damage to the drive. (-10~10V)

FP0.44	Speed command filter time	Setting range	Default	Unit	Available mode		
		0~6000	0	256μs	-	S	-

Detailed instruction:

This parameter is used to set the time constant of the 1st order low-pass filter corresponding to the analog speed command. By setting this parameter, the change of the speed will be more gently in cases the speed analog input changes largely. See the figure below:

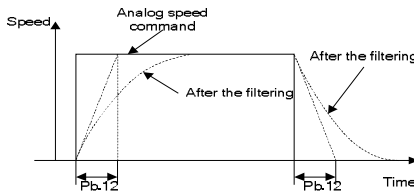

FP0.45	Dead zone of analog VA	Setting range	Default	Unit	Available mode		
		0.000~2.000	0.000	V	-	S	T

FP0.46	Internal speed/speed limit 1	Setting range	Default	Unit	Available mode		
		-6000.0~6000.0	100.0	r/min	-	S	T

FP0.47	Internal speed/speed limit 2	Setting range	Default	Unit	Available mode		
		-6000.0~6000.0	100.0	r/min	-	S	T

Detailed instruction:

The servo drive provides 4 stages of internal speed command/internal speed limit:

Control mode	Setting value of FP0.40	SC1	SC2	Relative parameters and setting
Speed mode	0	0	0	Setting value of FP0.46 Internal speed 1
		1	0	Setting value of FP0.47 Internal speed 2
		0	1	Setting value of FP0.48 Internal speed 3
		1	1	Setting value of FP0.49 Internal speed 4
Torque mode	0	0	0	Setting value of FP0.46 internal speed limit 1
		1	0	Setting value of FP0.47 internal speed limit 2
		0	1	Setting value of FP0.48 internal speed limit 3
		1	1	Setting value of FP0.49 internal speed limit 4

Note:

1. SC1 and SC2 are the wiring terminals for CN1. The corresponding relationships are listed in the table below:

0: OFF (the terminal is disconnected with COM-);

1: ON (the terminal is connected with COM-).

2. The speed limit depends on the absolute value of the corresponding parameter. The directions the same as that of the torque command.

3. The setting range of the parameter is subject to the power grade of the drive. The setting range of drives below (including) 2.0kW is -5000.0~5000.0, and above (including) 2.0kW is -3000.0~3000.0.

FP0.48	Internal speed/speed limit 3	Setting range	Default	Unit	Available mode		
		-6000.0~6000.0	100.0	r/min	-	S	T

FP0.49	Internal speed/speed limit 3	Setting range	Default	Unit	Available mode		
		-6000.0~6000.0	100.0	r/min	-	S	T
<p>Detailed instruction: The function of the parameters is the same as that of FP0.46 and FP0.47.</p>							

FP0.54	ACC time	Setting range	Default	Unit	Available mode		
		0~20000	0	ms	-	S	-
FP0.55	DEC time	Setting range	Default	Unit	Available mode		
		0~20000	0	ms	-	S	-

Detailed instruction:

ACC/DEC time means that in the case of internal reference speed command, the time required for the speed setting to increase from 0r/min to 3000r/min. When the speed setting is quicker or slower than 3000r/min, the actual ACC/DEC time is calculated at the proportion. If the speed command is a negative value, the ACC/DEC time is calculated with its absolute value.

For example, assuming that the reference speed is 2000r/min and the ACC/DEC time (FP0.54 and FP0.55) is set as 1500 and 1500, at this time the actual ACC time of the speed command is $1500 \times (2000/3000) = 1000(\text{ms})$ and the DEC time is $1500 \times (2000/3000) = 1000\text{ms}$.

The meaning of the ACC/DEC time is shown in the figure as below:

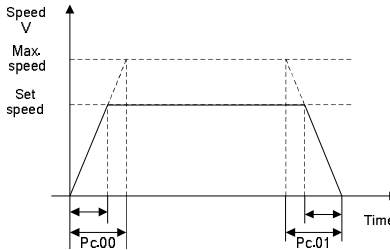

Note:

1. ACC/DEC time can only be used in the speed mode, and it is only valid when FP0.40 is set to 0.
2. ACC/DEC time is valid when using jogging function.

FP0.56	S curve ACC time	Setting	Default	Unit	Available
--------	------------------	---------	---------	------	-----------

		range			mode		
		0~1000	0	ms	-	S	-
FP0.57	S curve DEC time	Setting range	Default	Unit	Available mode		
		0~1000	0	ms	-	S	-

Detailed instruction:

In a case of internal reference speed command, this parameter is used to set the duration of the circular arc segment during S curve decelerating and thus to achieve the goal of smoothly stopping. The ACC/DEC time of S curve is shown in the figure below:

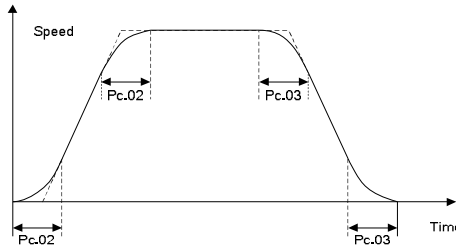

Note:

1. The ACC/DEC time of S curve can only be used in the speed mode and it is valid when FP0.40 is set to 0.
2. The ACC/DEC time of S curve is valid when using jogging function.

FP0.58	Stopping method	Setting range	Default	Unit	Available mode		
		0~1	0	-	-	S	-

Detailed instruction:

This parameter is used to set how the servo motor stops running when the zero speed clamp terminal (ZRS pin37) signal is set to ON in the speed mode:

0: Decelerate to stop. The DEC time is the setting values of parameter FP0.56 and FP0.57;

1: Instant stop. The DEC time is 0.

FP0.60	Torque command/torque limit selection	Setting range	Default	Unit	Available mode		
		0~1	0	-	P	S	T

Detailed instruction:

Control mode	Function name	Setting value of FP0.04	Input method	Instruction
Torque mode	Torque command	0	Internal torque command	Set the required torque by setting FP0.66. Please refer to the detailed instruction of PA. 11.
		1	External analog torque command	The output torque can be controlled by applying a voltage between -10V and 10V on the analog torque input terminals (TA+, TA- and pin 7 and 8). By factory default, the positive value means forward and negative value means reverse. But it can be changed by setting parameters. Please refer to the detailed instruction.
Speed mode or position mode	Torque limit selection	0	Internal torque limit	The output torque can be limited by setting the internal torque limit parameter (FP0.12) or the internal and external torque limit can be switched by changing the state of TQC and COM-. The direction of the torque limit is the same as that of the speed command. Please refer to the detailed instruction.
		1	External analog torque limit	The output torque can be limited by applying a voltage between -10V and 10V on the analog torque limit terminals (TA+, TA- and pin 7 and 8). The magnitude of the torque limit is the absolute value of the analog input, the direction of it is the same as that of the torque command. But it can be changed by setting parameters.

				Please refer to the detailed instruction.
--	--	--	--	---

Note: Please note that in the torque mode; do not allow the motor to run under the condition of negative load.

Parameter	FP0.62	Torque command	Setting range	Default	Unit	Available mode		
		input gain	10~300	10	%/v	P	S	T

Detailed instruction:

1. The voltage of set analog input TA corresponds to the switching gain of torque command.
2. The parameter is valid when FP0.60 is set to "1".
3. The relationship between analog TA input voltage and speed is default as each 1V: 10% of the rated torque

Running mode	FP0.60	Torque command/torque limit
Position/speed mode	0	FP0.12
	1	Input voltage X FP0.62
Torque mode	0	FP0.66
	1	Input voltage X FP0.62

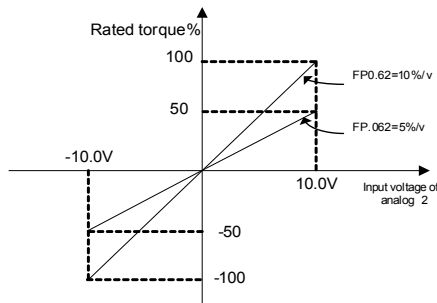

Note:

1. Analog input TA is the input signal from analog speed/speed limit terminal.
2. Set right parameter after ensure the running. Big setting value may cause big fluctuation of motor speed.

Parameter	FP0.64	Torque command filter time	Setting range	Default	Unit	Available mode		
			0~6000	0	256μs	-	-	T

Detailed instruction:

This parameter is used to set the time constant of the 1st order low-pass filter corresponding to the torque command. By setting this parameter, the actual output torque changes more gently in cases the torque command changes largely. See the figure below:

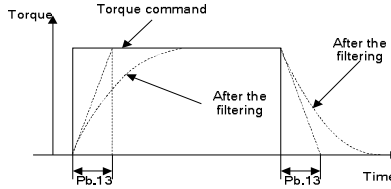

FP0.65	Dead zone of analog TA	Setting range	Default	Unit	Available mode		
		0.000~2.000	0.000	V	P	S	T

FP0.66	Internal torque command	Setting range	Default	Unit	Available mode		
		-250.0~250.0	10.0	%	-	-	T

Detailed instruction:

This parameter is used to set the internal torque setting. Taking the rated torque of the servo motor as 100%, this setting is the percentage of the rated torque of the servo motor.

Note:

1. If the absolute value of this parameter is larger than FP0.11, then the output torque is the value of FP0.11 and the direction is the same as that of the parameter.
2. In the torque mode, the parameter is valid if FP0.04 is set to 0.

6.2 Self-turning control parameters (FP1 group parameters)

6.2.1 Inertia identification(Automatic gain)

FP1.02	Rotational inertia ratio	Setting range	Default	Unit	Available mode		
		0~30	0	-	P	S	T

Detailed instruction:

This parameter is used to set the ratio of the load inertia converted into the rotor shaft to the inertia of the servo motor.

$$\text{Setting value of FP1.02} = \frac{\text{Load rotational inertia on the rotor shaft (J}_L\text{)}}{\text{Rational inertia of the rotor of the servo drive(J}_M\text{):}}$$

Parameter	Description	Setting range	Default	Unit	Available mode		
		0~31	13	--	P	S	T
FP1.03	Machine rigidity setting						
Detailed instruction: The bigger the value is, the faster response and higher rigidity and easier vibration. In stable system, higher rigidity setting makes fast response.							
		Mechanical structure	Rigid set				
		Big handling, transmission equipment	0~13				
		Belt drive mechanism	5~16				
		Manipulator	10~20				
		Ball screw + Belt drive	13~25				
		Direct ball screw or rigid bodies	18~31				

Parameter	Description	Setting range	Default	Unit	Available mode		
		0~1	0	--	P		
FP1.04	Inertia identification switch						
Detailed instruction: 0: Inertia identification switch off 1: Inertia identification switch on Note: 1. The parameter is valid in position mode; 2. The bigger value of FP1.06 and FP1.07, the faster the motor speed; 3. Refer to chapter 9.1 if the drive report Er-INE.							

Parameter	Description	Setting range	Default	Unit	Available mode		
		0~3	0	--	P		
FP1.05	Inertia identification operation						
Detailed instruction: In position mode, if FP1.04=1, the motor will: 0: Forward rotate and then reverse rotate 1: Forward rotate 2: Reverse rotate 3: Reverse rotate and then forward rotate							

Parameter	Description	Setting range	Default	Unit	Available mode		
		FP1.06	Mechanical movement	0.5~10	1.5	r	P

Detailed instruction:
In position mode, if the inertia identification is valid, the parameter can limit the maximum running revolutions in each cycle.

Parameter	Description	Setting range	Default	Unit	Available mode		
		FP1.07	Identification of inertia acceleration time constant	2~200	2	ms	P

Detailed instruction:
The setting of this parameter is the command of ACC time constant of the motor, other than the actual ACC time. the bigger the value, the longer the ACC time. if the load inertia is big enough, ACC time can be set as a long time to ensure the speed of the motor exceeds 150r/min.

6.2.2 Adaptive vibration control

Parameter	Description	Setting range	Default	Unit	Available mode		
		FP1.20	Resonance frequency test valid	0~1	0	-	P

Detailed instruction:
This parameter is used to set whether the resonance frequency is valid or not. If it is valid, the system will analysis the automatically-collected data and save the result to FP1.21 and FP1.22. The user can set the frequency of the notch filter according to the value of FP1.21 and FP1.22 to remove the resonance.
0: Resonance frequency test invalid
1: Resonance frequency test valid

Parameter	Description	Setting range	Default	Unit	Available mode		
		FP1.21	1 st mechanical resonance frequency	0~1500	0	Hz	P
FP1.22	2 nd mechanical resonance frequency	0~1500	0	Hz	P	S	T

Detailed instruction:
This parameter is used to display the resonance frequency. When FP1.20 is set to 1, the system will detect the frequency on the Max. resonance and display it by the function codes.

Note:

1. When the speed reaches above 30r/min, the measuring value will be correct.
2. This function is only for read and can not be set. The user can set the frequency of the notch filter according to the function code to remove the resonance.

Parameter Code	Parameter Name	Setting range	Default	Unit	Available mode		
		FP1.23	1 st trap wave center frequency	50~2000	2000	Hz	P

Detailed instruction:

This parameter is used to set the frequency of the 1st trap wave filter for suppressing resonance. The trap wave filters can simulate the mechanical resonant frequency and thus suppress the resonant frequency.

50~1999: trap wave frequency;
2000: invalid.

Parameter Code	Parameter Name	Setting range	Default	Unit	Available mode		
		FP1.24	1 st trap wave width	1.0~1000.0	50.0	Hz	P

Detailed instruction:

This parameter is used to set the trap wave width of the 1st trap wave filter for suppressing resonant. A larger trap wave width can be obtained with a larger setting.

Parameter Code	Parameter Name	Setting range	Default	Unit	Available mode		
		FP1.25	1 st trap wave depth	0.00~1.00	0.00	%	P

Detailed instruction:

This parameter is used to set the trap wave depth of the 1st trap wave filter for suppressing resonant. A larger trap wave depth can be less with a larger setting.

FP1.26	2 nd trap wave center frequency	Setting range	Default	Unit	Available mode		
		50.0~3000.0	3000.0	Hz	P	S	T
FP1.27	2 nd trap wave width	Setting range	Default	Unit	Available mode		
		1.0~1000.0	50.0	Hz	P	S	T
FP1.28	2 nd trap wave depth	Setting range	Default	Unit	Available mode		

			0.00~1.00	0.00	%	P	S	T
<p>Detailed instruction:</p> <p>Please refer to FP1.23, FP1.24 and FP1.25.</p> <p>Using the 1st and 2nd notch filters at the same time can suppress 2 mechanical resonant.</p>								

6.3 Motor control parameters (FP2 group parameters)

6.3.1 Gain

	FP2.00	1 st speed gain	Setting range	Default	Unit	Available mode		
			1~30000	1000	rad/s	P	S	-
<p>Detailed instruction:</p> <p>This parameter is used to set the gain of the speed loop. When the setting is increased, the speed response will be improved, but it may easily cause vibration and noise.</p>								

	FP2.01	1 st speed integration time constant	Setting range	Default	Unit	Available mode		
			1~5000	100	256μs	P	S	-
<p>Detailed instruction:</p> <p>This parameter is used to set the integration time constant of the speed loop. The response may be improved by decreasing the setting, but this parameter may easily cause vibration and noise. It should be noted particularly that when this parameter is set as 5000, it means the integral action is invalid.</p>								

	FP2.02	1 st position gain	Setting range	Default	Unit	Available mode		
			0.1~3000	48.0	1/s	P	-	-
<p>Detailed instruction:</p> <p>This parameter is used to set the gain of the position loop. When the setting is increased, the position response will be improved, but it may easily cause vibration and noise.</p>								

	FP2.03	1 st speed detection filter time	Setting range	Default	Unit	Available mode		
			0.00~100.00	0.00	ms	P	S	T
<p>Detailed instruction:</p>								

This parameter is used to set the time constant of the speed detect filter.

Parameter	Description	Setting range	Default	Unit	Available mode		
		FP2.04	1 st torque filter	0.00~25.00	0.84	ms	P

Detailed instruction:
This parameter is used to set the time constant of torque filter. Refer to [7.1.2](#).

Parameter	Description	Setting range	Default	Unit	Available mode		
		FP2.07	2 nd position gain	0.1~3000.0	57.0	1/s	P
Parameter	Description	Setting range	Default	Unit	Available mode		
		FP2.05	2 nd speed gain	0.1~3000.0	27.0	Hz	P
Parameter	Description	Setting range	Default	Unit	Available mode		
		FP2.06	2 nd speed integration time constant	0.1~1000.0	1000.0	ms	P
Parameter	Description	Setting range	Default	Unit	Available mode		
		FP2.08	2 nd speed detection filter time	0.00~100.00	0.05	ms	P
Parameter	Description	Setting range	Default	Unit	Available mode		
		FP2.09	2 nd torque filter	0.00~25.00	0.84	ms	P

Detailed instruction:
There are two groups of parameters for position gain, speed gain and speed integration time constant.
The definition of the function and content are the same as those of 1st group.
The user can select or switch between 1st gain and 2nd gain according to the requirement. Please refer to the detailed information of FP2.21 and FP2.22.

Parameter	Description	Setting range	Default	Unit	Available mode		
		FP2.10	Speed feed-forward gain	0.0~100.0	30.0	%	P

Detailed instruction:
This parameter is used to set the speed feed-forward gain.

Parameter	Description	Setting range	Default	Unit	Available mode		
FP2.11	Speed feed-forward						

	filter time constant	range			mode		
		0.00~60.00	0.50	ms	P	-	-
Detailed instruction:							
This parameter is used to set the speed feed-forward filter time constant.							

FP2.12	Torque feed-forward gain	Setting range	Default	Unit	Available mode		
		0.0~100.0	0.0	%	P	S	-
Detailed instruction:							
This parameter is used to set the torque feed-forward gain.							

6.3.2 Gain switching

FP2.21	Gain switching selection	Setting range	Default	Unit	Available mode		
		0~1	0	-	P	S	T
FP2.22	Gain switching condition	Setting range	Default	Unit	Available mode		
		0~5	0	-	P	S	-

Detailed instruction:

Setting value of FP2.22	Function						
0	Manual gain switching	When FP2.22 is set to 0, FP2.21 can set to gain switching selection. Carry out manual gain switching according to the relationship between the gain switching terminal and COM-.					
		Setting value of FP2.21	Function name	PLC	Content		
		0	Speed loop gain switching	0	Speed loop adjustor ——PI adjustment		
				1	Speed loop adjustor ——P adjustment		
		1	Switching from 1 st gain to 2 nd gain	0	1 st gain		
1	2 nd gain						
Note:							

		PLC is the wiring terminal of CN1 (pin 36). Below is its relationship with COM-: 0: OFF(the terminal is disconnected with COM-); 1: ON (the terminal is connected with COM-).
1	Fix to the 2 nd gain	
2	When the retention pulse is too large, select the 2 nd gain, otherwise select the 1 st gain and the threshold of the retention pulse is set with FP2.25	
3	When the speed command is too large, select the 2 nd gain, otherwise select the 1 st gain and the threshold of the speed command is set with FP2.25	
4	When the speed command is relatively small, select the 2 nd gain, otherwise select the 1 st gain and the threshold of the speed command is set with FP2.25	
5	Position command + speed gain switching mode. In the position mode, when no position command pulse is inputted, it will select the 1 st gain. When a position command pulse is inputted, it will select the 2 nd gain. After the position command pulse stops input for 3ms and the motor speed falls below the speed threshold set with FP2.25, it will switch to the 1 st gain.	

FP2.23	Gain switching time constant	Setting range	Default	Unit	Available mode		
		0~1000	0	ms	P	S	T

Detailed instruction:
This parameter is used to set the time constant of the transition process when switching between the 1st gain and 2nd gain. This parameter is active only for the proportional parameters. By setting this parameter we can lighten the mechanical shock caused by gain switching. See chapter 7.3 for details.

FP2.25	Gain switching threshold	Setting range	Default	Unit	Available mode		
		0~6000	0	256μs	P	S	-
		0~500.0	10.0	r/min			

Detailed instruction:
The setting content of this parameter is relative to the setting value of FP2.22:

Setting value of	The setting content of FP2.25 during
------------------	--------------------------------------

	FP2.22	gain switching
	2	Retention pulse threshold
	3	Speed threshold
	4	
	5	

6.3.3 Special motor control

FP2.47	Speed compensation threshold	Setting range	Default	Unit	Available mode		
		0~20000	100	pulse	P	-	-
FP2.48	Speed compensation	Setting range	Default	Unit	Available mode		
		0.0~500.0	0.0	r/min	P	-	-

Detailed instruction:

FP2.47 is used to set the retention pulse threshold of the speed compensation on the position mode.

In the position mode, if the absolute value of the retention pulse is above the setting value of FP2.47. And FP2.48 can be added on the speed command to decrease the time of position reaching. The function is shown as below:

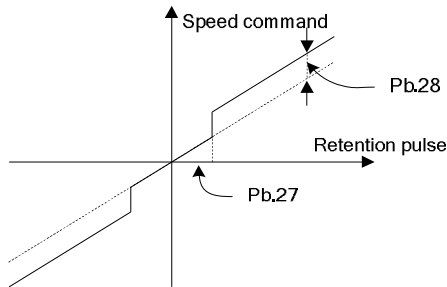

6.4 I/O management parameters (FP3 group parameters)

6.4.1 Digital input

FP3.00	Polarity reversing of digital quantity	Setting range	Default	Unit	Available mode		
		00000~11111	00000	-	P	S	T

Detailed instruction:

This parameter is used to reverse the polarity of the digital quantities. It is a binary number. Each bit corresponds to a digital input. 0 indicates that the polarity does not change. 1 indicates to reverse the polarity of the digital quantity corresponding to this

bit. The corresponding relationships between each bit and the digital quantity are:

BIT4	BIT3	BIT2	BIT1	BIT0
RPC	PLL	CLA	ZRS	SON

Details (Refer to chapter 4.5.8.3 for detailed description of the signs of the digital quantities) :

BIT	ON-OFF signs of CN1	Function name	Available mode		
BIT0	SON	Servo enabling	P	S	T
BIT1	ZRS	Zero speed clamp-on	P	S	T
BIT2	CLA	Alarm clearance	P	S	T
BIT3	PLL	Pulse input inhibit	P	-	-
BIT4	RPC	Retention pulse clearance	P	-	-
		Speed reversing	-	S	-

6.4.2 Analog input / output adjustment

FP3.20	Offset voltage of AI VA	Setting range	Default	Unit	Available mode		
		-2.000~2.000	0.000	V	-	S	T
FP3.23	Offset voltage of AI TA	Setting range	Default	Unit	Available mode		
		-2.000~2.000	0.000	V	P	S	T

Detailed instruction:

This parameter can be used to adjust the AI1 and AI2 to improve the effective accuracy for the analog input.

Due to zero drift of the AI devices and other reasons, the actual AI corresponding value may deviate from the expected value. At this time it can be eliminated by setting the offset of AI. Similarly, the deviation of the actual AO value from the expected corresponding value caused by zero drift of AO devices and other reasons can be eliminated by setting the offset of AO.

The meaning of the analog offset voltage is shown in the figure as below:

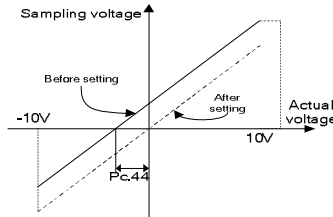

For example, after the analog setting signal is connected into the AI terminal (VA) of the drive, even though the analog setting signal is 0, the front panel displays the analog speed command voltage (dp-An1) is 0.02V. On this condition, parameter FP3.20 should be set as 0.02. The drive will automatically subtract 0.02V from the AI value received. If the front panel displays the analog speed command voltage is -0.02V, parameter FP3.20 should be set as -0.02. The drive will automatically add 0.02V to the AI value received.

FP3.30	AO 1 selection	Setting range	Default	Unit	Available mode		
		0~7	0	-	P	S	T
FP3.32	AO 2 selection	Setting range	Default	Unit	Available mode		
		0~7	0	-	P	S	T

Detailed instruction:

This group of parameters is used to select the monitoring parameters to be outputted in analog form.

Parameter	Setting value	Definition	Relative parameters
FP3.30 AO 1 selection	0	Motor speed	Adjust FP3.33 to set the corresponding analog output signal.
	1	Output torque	
	2	Output current	
	3	Bus voltage	
	4	Speed setting	
	5	Torque given	
	6~7	Reserved	
FP3.32 AO 2 selection	0	Motor speed	Adjust FP3.33 to set the corresponding analog output signal.
	1	Output torque	
	2	Output current	
	3	Bus voltage	
	4	Speed setting	

		5	Torque given	
		6~7	Reserve	

	FP3.31	Voltage gain of AO 1	Setting range	Default	Unit	Available mode		
			0~1000	500	-	P	S	T
	FP3.33	Voltage gain of AO 2	Setting range	Default	Unit	Available mode		
			0~1000	500	-	P	S	T

Detailed instruction:

This group of parameters defines the relationships between the analog output voltage and its corresponding setting. When the analog output voltage exceeds the set upper limit or lower limit range, the part beyond will be calculated with the upper limit or lower limit.

Detailed meaning of the analog output is selected by FP3.30 and FP3.32. Corresponding setting of the lower and upper limit are expressed by percentages. The maximum is taken as 100% and the determination of the maximum is listed in the table below:

FP3.30 and FP3.32	Outputs	Maximum
0	Motor speed	-
1	Output torque	3 times of the servo motor rated torque
2	Output current	3 times of the servo motor rated current
3	Bus voltage	-
4	Speed setting	-
5	Torque setting	3 times of the servo motor rated torque

Take a 400W servo drive as an example. Output the actual speed from the analog output 1 terminal (AO1) to observe, so 10V corresponds to 3000r/min and 0V corresponds to 0r/min. On this condition, set FP3.30=0, Pc.36=0.00, Pc.38=8.00, Pc.37=0.0, Pc.39=100.0, the relationship between the actual speed setting and the output voltage is shown in the figure as below:

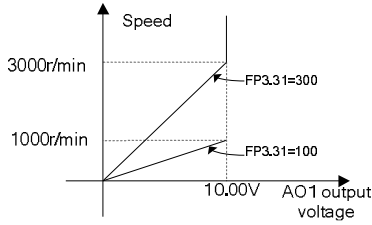

Note:

1. AO1 means the signal output from the AO1 terminal (AO1 pin21) and AO2 means the signal output from the AO2 terminal (AO2 pin25). The output signal has no directional properties and stands for the absolute value of the setting signal.
2. The maximum value of the motor speed, speed setting and bus voltage depends on the power grade of the drive.

FP3.34	Offset voltage of AO1	Setting range	Default	Unit	Available mode		
		-2.00~2.00	0.00	V	P	S	T
FP3.35	Offset voltage of AO2	Setting range	Default value	Unit	Available mode		
		-2.00~2.00	0.00	V	P	S	T

Detailed instruction:

This parameter can be used to adjust the AO1 and AO2 to improve the effective accuracy for the analog input. Due to zero drift of the AI devices and other reasons, the actual AO corresponding value may deviate from the expected value. At this time it can be eliminated by setting the offset of AO. Similarly, the deviation of the actual AO value from the expected corresponding value caused by zero drift of AO devices and other reasons can be eliminated by setting the offset of AO.

Please refer to FP3.20 and FP3.23 for the detailed setting.

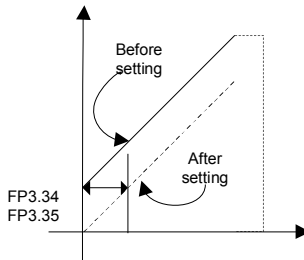

6.4.3 Switch input / output settings

FP3.40	Travel limit switch	Setting	Default	Unit	Available
--------	---------------------	---------	---------	------	-----------

	shield	range			mode		
		0~1	0	-	P	S	T

Detailed instruction:

This parameter is used to set the input signals of the forward travel limit terminal (PSL pin 3) and reverse travel limit terminal (RVL pin 4) of CN1 are active or inactive. If the function of the travel limit switch needs to be shielded, set this parameter.

0: Signals of the travel limit terminals are inactive;

1: Signals of the travel limit terminals are active.

If PSL and RVL are connected with COM-, the state is normal and if they are disconnected with COM-, alarm will occur.

Wiring terminal of CN1	State (with COM-)	State of the drive
PSL	Connecting	Normal working
RVL	Connecting	
PSL	Disconnecting	Forward travel limit alarm AL-LT1。
RVL	Disconnecting	Reverse travel limit alarm AL-LT2。

Note:

1. If AL-LT1 or AL-LT2 occurs, the servo drive will stop at the stopping mode set by FP4.30.
2. The clearance of AL-LT1 or AL-LT2: If the travel limit alarm takes effective, the reverse command will be sent to the drive, and then the motor will be out of the travel limit zone and report the automatic clearance of the alarm.

FP3.41	E-stop shield	Setting range	Default	Unit	Available mode		
		0~1	0	-	P	S	T

Detailed instruction:

This parameter is used to set the input signal of the emergency stop terminal (EMG pin 39) is active or inactive. If the function of the E-stop needs to be shielded, set this parameter.

0: Signal of the emergency stop terminal is inactive;

1: Signal of the emergency stop terminal is active.

If EMG is connected with COM-(NC), the state is normal; if the terminal is disconnected with COM-, then AL-EST will occur.

Note:

1. If AL-EST occurs, the servo drive will stop at the stopping mode set by FP4.30.

2. The clearance of AL-EST: Please ensure there is no danger, and then clear the alarm signal (i.e. connecting EMG with COM). If the alarm is displayed to be cleared (CLA function), it is necessary to enable the servo drive again, and the system will work normally.

Parameter	FP3.50	Range of position reaching	Setting range	Default	Unit	Available mode		
			0~20000	100	pulse	P	-	-

Detailed instruction:

This parameter is used to set the range of position reaching. When the deviation between the position feedback pulse and position command pulse are in this range, it is considered that it has reached the position and the output transistor of the position reaching terminal (PLR pin11) signal comes into conduction.

Parameter	FP3.54	Range of speed reaching	Setting range	Default	Unit	Available mode		
			0~1000.0	30.0	r/min	-	S	-

Detailed instruction:

This parameter is used to set the range of speed reaching. When the deviation between the speed feedback pulse and speed command pulse are in this range, it is considered that it has reached the speed and the output transistor of the speed reaching terminal (SR pin30) signal comes into conduction.

Parameter	FP3.55	Zero speed range	Setting range	Default	Unit	Available mode		
			0~1000.0	50.0	r/min	P	S	T

Detailed instruction:

This parameter is used to set the zero speed range. When the absolute value of the speed feedback is in this range, it is considered as zero speed and the output transistor of the zero speed terminal (ZSO pin29) signal comes into conduction.

Parameter	FP3.56	Locked time of servo after braking	Setting range	Default	Unit	Available mode		
			100~5000	100	ms	P	S	T

Detailed instruction:

This parameter is used to set the locked time of the servo after braking in the locked state. The servo is OFF in the locked state, the output transistor of the brake releasing terminal (BRK pin 9) signal turns off. At this time, the servo will continue to be locked

for a period of time so that the motor will not rotate during the action of the relay. Refer to chapter 5.1.10 for the sequence relationship.

FP3.57	Braking delay time of the electromagnetic brake	Setting range	Default	Unit	Available mode		
		0~5000	1000	ms	P	S	T
Detailed instruction: This parameter is used to set the braking delay time of the electromagnetic brake. The servo is OFF or an alarm occurs in the running state, in this condition, the speed may be relatively high, so the output transistor of the brake releasing terminal (BRK) signal can be turned off after a delay time. If the speed falls below 30r/min within the delay time, the output transistor of the BRK signal will be turned off ahead of time. Please refer to chapter 5.1.10 for its sequence relationship.							

6.5 Extension and application (FP4 group parameters)

6.5.1 Communication setting

*FP4.00	Communication mode	Setting range	Default	Unit	Available mode		
		0~1	1	-	P	S	T
Detailed instruction: This parameter is used to select the communication mode. The communication modes are: 0: RS232; 1: RS485.							

FP4.01	Local communication address	Setting range	Default	Unit	Available mode		
		0~31	1	-	P	S	T
Detailed instruction: This parameter is used to set the communication address of the local drive for RS485 serial communication.							

FP4.02*	Communication baud rate selection	Setting range	Default	Unit	Available mode		
		0~4	0	-	P	S	T
Detailed instruction: This parameter is used to select the communication baud rate. Available baudrate are							

as follow:

- 0: 9600bps;
- 1: 19200bps;
- 2: 38400bps;
- 3: 57600bps;
- 4: 115200bps.

FP4.04	Communication parity mode	Setting range	Default	Unit	Available mode		
		0~17	0	-	P	S	T
<p>Detailed instruction:</p> <ul style="list-style-type: none"> 0: None (8, N, 1) for RTU; 1: Even (E, 8, 1) for RTU; 2: Odd (8, O, 1) for RTU; 3: None (8, N, 2) for RTU; 4: Even (E, 8, 2) for RTU; 5: Odd (O, 8, 2) for RTU; 6: None (N, 7, 1) for ASCII; 7: Even (E, 7, 1) for ASCII; 8: Odd (O, 7, 1) for ASCII; 9: None (N, 7, 2) for ASCII; 10: Even (E, 7, 2) for ASCII; 11: Odd (O, 7, 2) for ASCII; 12: None (N, 8, 1) for ASCII; 13: Even (E, 8, 1) for ASCII; 14: Odd (O, 8, 1) for ASCII; 15: None (N, 8, 2) for ASCII; 16: Even (E, 8, 2) for ASCII; 17: Odd (O, 8, 2) for ASCII; 							

FP4.05	Communication response delay time	Setting range	Default	Unit	Available mode		
		0~200	0	ms	P	S	T
<p>Detailed instruction:</p> <p>Communication response delay time means the interval between the time when the subordinate machine receives the response data (the machine means servo drives) and the time when sending response data to the upper PC. If the response delay time is longer than the processing time of the system, after completion of data processing,</p>							

the system will wait until the response delay time is over before transmitting data to the upper PC.

Parameter	Description	Setting range	Default	Unit	Available mode		
		FP4.06	Communication overtime fault time	0~60.0	0.0	s	P

Detailed instruction:

When this parameter is set as 0.0s, it does not perform communication overtime detection.

When it is set as other valid values, if the interval time between one communication and the next communication exceeds the setting of the communication overtime fault time, the servo drive will report a communication fault alarm (Er-CT).

In general, the communication overtime detection is set as inactive. In a system that communicates continuously, the communication state can be monitored instantaneously by setting this parameter.

Parameter	Description	Setting range	Default	Unit	Available mode		
		FP4.07	Communication fault processing method	0~1	0	-	P

Detailed instruction:

This parameter is used to select the action of the servo drive when a communication fault alarm occurs:

0: Alarms and stops (with the stopping mode set by parameter Pc. 52);

1: Do not alarm and continue to run.

Parameter	Description	Setting range	Default	Unit	Available mode		
		FP4.08	Communication response enabling	0~1	1	-	P

Detailed instruction:

This parameter is used to select whether a response is required when a parameter is written through communication:

0: Response is unnecessary;

1: Response is necessary.

Parameter	Description	Setting range	Default	Unit	Available mode		
		FP4.09	Reserved	-	-	-	P

6.5.2 Alarm threshold setting

FP4.30	Stopping mode selection	Setting range	Default	Unit	Available mode		
		0~4	3	-	P	S	T

Detailed instruction:

When the servo is turned OFF and when an fault alarm occurs, this parameter is used to set whether the dynamic brake works or not as well as the state selection of the servo motor after stop:

Setting value of FP4.30	Action	
	During deceleration	After stopping
0	Coast to stop	Keep the dynamic braking state
1	Dynamic brake to stop	Keep the dynamic braking state
2	Dynamic brake to stop	Keep the inertia running state
3	Coast to stop	Keep the inertia running state
4	The drive locks the time set by FP3.56 and coast to stop	Keep the inertia running state

Note: If the servo motor exceeds the rated speed and runs at high speed, please do not activate the dynamic brake. If the servo motor runs at higher speed with a load which has large inertia, please be prudent in activating the dynamic brake. Avoid by all means activating the dynamic brake too frequently as this may damage the servo drive.

FP4.31	Max speed limit	Setting range	Default	Unit	Available mode		
		-	-	r/min	P	S	T

Detailed instruction:

This parameter can be used to set the highest speed the servo motor can run. If the absolute value of the speed command is larger than the value of this parameter, the magnitude of the actual speed setting will be limited by this parameter; the direction is the same as that of the original speed command. This parameter is active in all modes.

Note: The default value of this parameter is related to the power level of the drive. The

default value of drives below 750W (including) is 5000.0 and above is 2500.0. The setting range of drives below 2.0kW is 0~5000.0 and above 2.0kW is 0~3000.0.

FP4.32	Overspeed level	Setting range	Default	Unit	Available mode		
		-	0	r/min	P	S	T
<p>Detailed instruction:</p> <p>This parameter is used to set the overspeed level of the servo motor. When the rotation speed of the motor exceeds this speed setting, an overspeed fault alarm will be reported.</p> <p>Note: The default of this parameter is related to the power level of the drive: the default value of drives below 750W (including 750W) is 6000.0 and the drives above 750W is 3000.0. The setting range of drives below 2.0kW (including 2.0kW) is 0~5000.0 and the drives above 2.0kW is 0~3000.0.</p>							

FP4.33	Pulse range for over-position	Setting range	Default	Unit	Available mode		
		0~50000	20000	pulse	P	-	-
<p>Detailed instruction:</p> <p>This parameter is used to set the alarm threshold for the over-position fault (ER-oE). In the position mode, when the number of retention pulses exceeds this setting, an over-position fault alarm will be reported</p>							

FP4.34	Brake overload detection enabling signal	Setting range	Default	Unit	Available mode		
		0~1	1	-	P	S	T
<p>Detailed instruction:</p> <p>This parameter is used to shield the brake overload protection function.</p> <p>0: Invalid; 1: Valid.</p>							

6.6 Factory parameters (FP9 group parameters)

FP9.00	Factory password	Setting range	Default	Unit	Available mode		
		0~65535	00000	-	P	S	T

Detailed instruction:

This parameter is the factory parameter password. The factory parameters are not open to the user. The user is advised not to try to get into this group of factory parameters. Otherwise it may cause malfunction or damage to the drive.

6.7 State monitoring

	r00-SPd	Motor speed	Symbol	Accuracy	Unit
			r00-SPd	0.1	r/min
Detailed instruction: Display the actual rotation speed of the motor.					

	r01-FP1	Lower 5 bits of feedback pulse accumulation	Symbol	Accuracy	Unit
			r01-FP1	1	pulse
Detailed instruction: : Count and display the lower 5 bits of accumulated pulse fed back from the encoder of the servo motor, with sign bit.					

	r02-FP2	Medium 5 bits of feedback pulse accumulation	Symbol	Accuracy	Unit
			r02-FP2	1	pulse
Detailed instruction: : Count and display the medium 5 bits of accumulated pulse fed back from the encoder of the servo motor, with sign bit.					

	r03-FP3	Higher 5 bits of feedback pulse accumulation	Symbol	Accuracy	Unit
			r03-FP3	1	pulse
Detailed instruction: Count and display the higher 5 bits of accumulated pulse fed back from the encoder of the servo motor, with a sign bit.					

	r04-rP1	Lower 5 bits of command pulse accumulation	Symbol	Accuracy	Unit
			r04-rP1	1	pulse
Detailed instruction:					

Count and display the lower 5 bits of the number of the accumulated input pulses. The displayed number is the pulse number before being amplified by the electronic gear. The displayed content may not be consistent with the accumulated number of the feedback pulses, with a sign bit.

			Symbol	Accuracy	Unit
	r05-rP2	Medium 5 bits of command pulse accumulation	r05-rP2	1	pulse

Detailed instruction:

Count and display the medium 5 bits of the number of the accumulated input pulses. The displayed number is the pulse number before being amplified by the electronic gear. The displayed content may not be consistent with the accumulated number of the feedback pulses, with a sign bit.

			Symbol	Accuracy	Unit
	r06-rP3	Higher 5 bits of command pulse accumulation	r06-rP3	1	pulse

Detailed instruction:

Count and display the higher 5 bits of the number of the accumulated input pulses. The displayed number is the pulse number before being amplified by the electronic gear. The display content may not be consistent with the accumulated number of the feedback pulses, with a sign bit.

			Symbol	Accuracy	Unit
	r07-EP	Retention pulse	r07-EP	1	pulse

Detailed instruction:

Display the number of retention pulses of the position deviation counter. The 6th bit is the sign bit.

			Symbol	Accuracy	Unit
	r08-An1	Analog speed command voltage	r08-An1	0.01	V

Detailed instruction:

In the speed mode: display the voltage value of the analog speed command.

In the torque mode: display the voltage value of the analog speed limit.

			Symbol	Accuracy	Unit
	r09-An2	Analog torque command voltage	r09-An2	0.001	V

Detailed instruction:

In the torque mode: display the voltage value of the analog torque command.

In the speed mode: display the voltage value of the analog torque limit.

	r10-ud1	Bus voltage of main circuit	Symbol	Accuracy	Unit
			r10-ud1	1	V
Detailed instruction: Display the bus voltage value of the main circuit.					

	r11-ud2	Bus voltage of control circuit	Symbol	Accuracy	Unit
			r11-ud2	1	V
Detailed instruction: Display the bus voltage value of the control circuit.					

	r12-cur	RMS value of current output current	Symbol	Accuracy	Unit
			r12-cur	0.01	A
Detailed instruction: Display the RMS value of motor.					

	r13-Tq	Current torque	Symbol	Accuracy	Unit
			r13-Tq	1	%
Detailed instruction: Display the RMS value of motor.					

	r14-Tn	Drive module temperature	Symbol	Accuracy	Unit
			r14-Tn	0.1	°C
Detailed instruction: Display the current temperature of IGBT module of the drive.					

	r15-Ld	Average load rate	Symbol	Accuracy	Unit
			r15-Ld	1	%
Detailed instruction: Display the continuous actual load. Taking the rated power of the servo motor as 100%, convert the actual value into a percentage to display.					

	r16-PoS	Position relative to Z	Symbol	Accuracy	Unit
--	---------	------------------------	---------------	-----------------	-------------

		pulse	r16-PoS	1	pulse
Detailed instruction: Display the position of the rotor relative to Z pulse in one revolution. The unit is pulse.					

	r17-inE	Inertia ratio of load	Symbol	Accuracy	Unit
			r17-inE	1	Time
Detailed instruction: Display the predicted value of the ratio of rotational inertia of the servo motor to that of the load converted onto the servo motor's shaft in real-time.					

	r18-oAL	Third latest fault alarm code	Symbol	Accuracy	Unit
			r18-oAL	-	-
	r19-AL	Second latest fault alarm code	Symbol	Accuracy	Unit
			r19-AL	-	-
	r20-ALC	Latest fault alarm code	Symbol	Accuracy	Unit
			r20-ALC	-	-
Detailed instruction: Display the latest, second latest and third latest fault alarm codes.					

	r21-in	Digital input state	Symbol	Accuracy	Unit
			r21-in	-	-
	r22-ou	Digital output state	Symbol	Accuracy	Unit
			r22-ou	-	-

Detailed instruction:
This value is a hexadecimal number arranged in the sequence of the digital quantities to indicate the state of all digital quantities. When a terminal is in ON state, its corresponding bit is denoted as 1. When a terminal is in OFF state, its corresponding bit is denoted as 0. Then, this binary number is converted into a hexadecimal number. For example, 000000001011 is denoted as 00B.

The digital input state is denoted with 4 digits of hexadecimal number. The arrangement sequence of the digital input is: (the digits not listed are filled with 0)

BIT12	BIT11	BIT10	BIT9	BIT8	BIT7	BIT6	BIT5	BIT4	BIT3	BIT2	BIT1	BIT0
MCH	PLC	TQC	PLL	RPC	RVL	PSL	SC2	SC1	EMG	CLA	ZRS	SON

The digital output state is denoted with 2 digits of hexadecimal number. The arrangement sequence of the digital output is:

BIT6	BIT5	BIT4	BIT3	BIT2	BIT1	BIT0
LM	BRK	SR	ZSO	PLR	ALM	RDY

	r23-tt	Motor temperature	Symbol	Accuracy	Unit
			r23-tt	0.1	℃
Detailed instruction: Display the current temperature of motor.					

	r24-uE1	DSP software version	Symbol	Accuracy	Unit
			r24-uE1	-	-
Detailed instruction: Display the version number of current DSP software.					

	r25-uE2	FPGA software version	Symbol	Accuracy	Unit
			r25-uE2	-	-
Detailed instruction: Display the version number of current FPGA software.					

	r26-uuu	Encoder feedback	Symbol	Accuracy	Unit
			r26-uuu	-	-
Detailed instruction: Display current value of encoder (U, V and W) feedback.					

	r27-iA	Instantaneous value of phase U output current	Symbol	Accuracy	Unit
			r27-iA	0.01	A
Detailed instruction: Display the instantaneous value of current phase U output current.					

	r28-ib	Instantaneous value of phase V output current	Symbol	Accuracy	Unit
			r28-ib	0.01	A
Detailed instruction: Display the instantaneous value of current phase V output current.					

	r29-iAF	Instantaneous value of phase U output current when an fault occurs	Symbol	Accuracy	Unit
			r29-iAF	0.01	A
Detailed instruction: Display the instantaneous value of phase U output current when a fault occurs.					

r30-ibF	Instantaneous value of phase V output current when an fault occurs	Symbol	Accuracy	Unit
		r30-ibF	0.01	A
Detailed instruction: Display the instantaneous value of phase V output current when a fault occurs.				

r31-udF	Value of bus voltage when an fault occurs	Symbol	Accuracy	Unit
		r31-udF	1	V
Detailed instruction:Display the value of bus voltage when an fault occurs.				

r32-Sn1	Drive serial No.1	Symbol	Accuracy	Unit
		r32-Sn1	-	-
Detailed instruction:Display the drive serial No.1				

r33-Sn2	Drive serial No.2	Symbol	Accuracy	Unit
		r33-Sn2	-	-
Detailed instruction:Display the drive serial No.2				

r34-Sn3	Drive serial No.3	Symbol	Accuracy	Unit
		r34-Sn3	-	-
Detailed instruction:Display the drive serial No.3				

r35-Sn4	Drive serial No.4	Symbol	Accuracy	Unit
		r35-Sn4	-	-
Detailed instruction:Display the drive serial No.4				

r36-Sn5	Drive serial No.5	Symbol	Accuracy	Unit
		r36-Sn5	-	-
Detailed instruction:Display the drive serial No.5				

r37-Sn6	Drive serial No.6	Symbol	Accuracy	Unit
		r37-Sn6	-	-
Detailed instruction:Display the drive serial No.6				

7 Gain adjustment

7.1 General method for adjusting parameters

When the servo system oscillates or the control performance becomes not sound, you can improve the system performance or eliminate the oscillation by adjusting the parameters of the speed loop and position loop. Hereunder we describe the general principle and method for the adjustment:

Gain of the speed loop: mainly used to determine the response speed of the speed loop. Under the precondition the mechanical system does not vibrate, the larger the setting of this parameter, the higher the response speed.

Speed loop integration time constant: the speed loop has an integrator which can reflect minor input. This integrator can delay the operation of the servo system. Therefore, when the time constant increases, the response becomes slower, and the required positioning setting time is longer. When the load inertia is larger or the mechanical system is likely to vibrate, the loop integration time parameter must be large enough to avoid the vibration of the mechanical system.

Torque command filter: in some cases the mechanical system may resonate, generating vibration noise of sharp tone. At this time trap wave filtering must be performed to eliminate resonance.

Gain of the position loop: the reaction of the servo system is determined by the gain of the position loop. When the gain of the position loop is set higher, the reaction speed will increase and the time required for positioning will be shortened. If you want to set the gain of the position loop to a high value, the rigidity and natural frequency of the mechanical system must be very high.

In general case the gain of the speed loop should be ensured higher than the gain of the position loop whenever possible. When the position gain is much higher than the speed gain, the system may overshoot under the action of the step signal. This will seriously damage the system performance. Various parameters of the system always limit each other. If only the gain of the position loop increases, the command outputted by the position loop may become unstable. This may cause the reaction of the entire servo system to become unstable. In general cases, we can adjust the system by referring to the follow procedures:

- 1) First set the gain of the position loop at a lower value, then, under the precondition that abnormal sound and vibration are not generated, gradually increase the gain of the speed loop to the maximum.
- 2) Gradually decrease the gain of the speed loop while increasing the gain of the position loop.

Under the precondition that the whole response is free from overshoot and vibration, set the gain of the position loop to the maximum.

3) Speed loop integration time constant depends on the length of the positioning time. Please decrease this value as small as possible under the precondition that the mechanical system does not vibrate.

4) After that, finely adjust the gain of the position loop, speed loop and the integration time constant to find their optimal values.

Hereunder we illustrate several typical cases (in each case, only one parameter is changed relative to a case when the parameters are appropriate):

◆ Parameters are appropriate

In this case the parameters are set relatively appropriate. The motor speed can closely follow the position command, the speed has basically no overshoot, and the positioning time is relatively short.

◆ Speed loop integration time constant is relatively small

The speed loop of the servo drive must have high reaction speed. When the speed fluctuates, it indicates that the stability of the speed loop is damaged due to the shorting integration time of the speed loop. This causes the servo motor to run unstably at fluctuating speed.

◆ Speed loop integration time constant is relatively large

In this case, there is no apparent difference with the case when the parameters are appropriate. The influence of the speed loop integration on the speed follow-up position command is not very high, but too large speed loop integration time will delay the reaction time of the speed loop.

◆ Gain of the speed loop is relatively high

In this case, the motor speed will fluctuate. The influence is the same as the case when the speed loop integration time is too short. Both of them must keep coordinated. While increasing the gain of the speed loop, the speed loop integration time must also be increased. Otherwise the servo system will oscillate.

◆ Gain of the speed loop is too low

Decreasing the gain of the speed loop will cause fluctuation of the motor speed to fluctuate. By comparing with the case when the speed gain is too high we can know that the fluctuation frequency of the motor speed is lower in this case which fully indicates that increasing the gain of the speed loop can heighten the operating frequency of the system, improve the quick response performance of the system, and effectively overcome the influence of the interference.

◆ Gain of the position loop is excessively low

In the servo system, the operating frequency of the position loop is much lower than the speed loop. When the gain of the position loop is too low, the system is difficult to eliminate the position deviation formed during speed response. This can cause prolongation of the time interval of the motor speed follow-up position command.

◆ Gain of the position loop is excessively high

In the position servo system, the gain of the position loop also affects the stability. At this time, as the gain of the position loop is excessively high, it makes the motor speed to fluctuate. Additionally, comparing with the case when the gain of the position loop is too low we can know that the pure time delay of the response to the position command of the motor speed is decreased.

◆ Gain of the position loop is too low

When we adjust the gain of the position loop to a low value, the motor speed follow-up position command represents obvious lag and the positioning time is prolonged largely. The high accuracy and high response performance of the positioning system are seriously affected.

7.1.1 Adjustment of the gain of the position loop

The position control block diagram of the SV-DB100 series servo drive is shown in the figure below. The gain parameters that can be adjusted in the position mode are marked out on the block diagram.

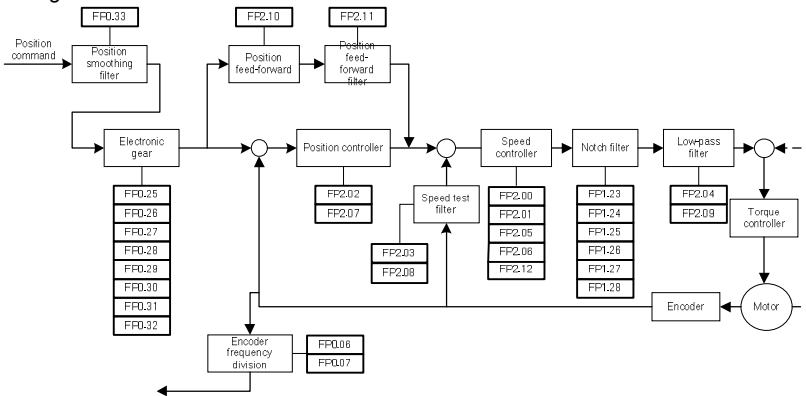

Fig. 7-1 Block diagram of position control

The general procedures for parameter adjustment in the position mode are:

1) Initial setting of the parameters

The defaults of the parameters can be recovered by the default parameter recovering operation (see chapter 5.2.4 for details).

2) Adjustment of the gain of the position loop

When the servo motor is running with default parameters, if the system oscillation occurs with buzz, the position gain should be adjusted smaller. If the system rigidity is relatively small, the position gain should be adjusted larger.

3) Adjustment of the position smoothing filter

During position control, if the position pulse commands input frequency varies largely, it may be caused by a larger impulse. At this time the position smoothing filters time constant should be adjusted to moderate the impulse.

4) Adjustment of the electronic gear

If the pulse transmission frequency of the pulse generator is restricted, or the transmission frequency does not meet the mechanical requirements, we can change the pulse input frequency by adjusting the value of the electronic gear parameters to meet the requirements for position control.

5) Adjustment of position feed-forward

In the case the retention pulse is large or fault-free follow-up is required, we can improve the position follow-up performance by adjusting the speed feed-forward gain parameter and speed feed-forward gain filter parameter. However, it should be noted that if the speed feed-forward gain is too large, it may cause system oscillation.

6) Frequency division of the feedback pulse output

If the feedback pulse needs to be outputted, the frequency division coefficient of pulse output can be used to change the frequency of the output pulse.

7.1.2 Adjustment of the gain of the speed loop

The speed control block diagram of the SV-DB100 series servo drive is shown in the figure below. The gain parameters that can be adjusted in the speed mode are marked on the block diagram.

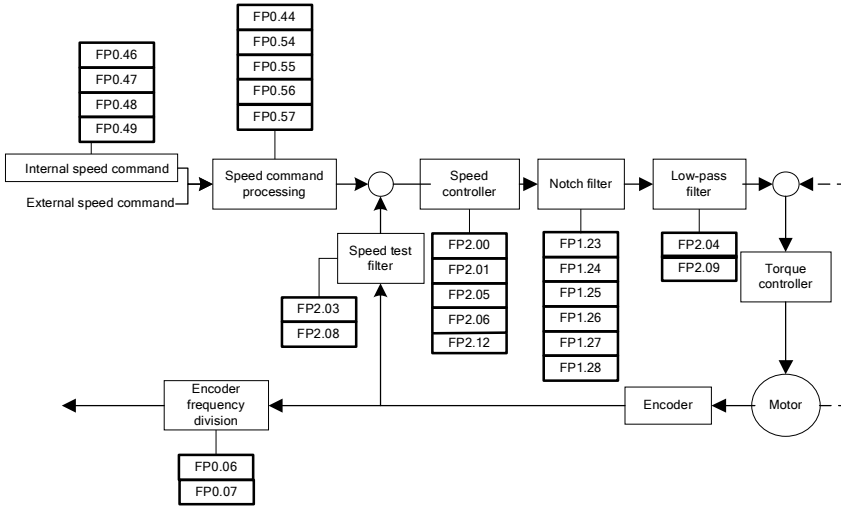

Fig. 7-2 Block diagram of speed control

The general procedures for parameter adjustment in the speed mode are:

1) Initial setting of the parameters

The defaults of the parameters can be recovered by the default parameter recovering operation (see chapter 5.2.4 for details).

2) Adjustment of the gain of the speed loop

When the servo motor is running with default parameters, if the system oscillation occurs with buzz, the speed gain should be adjusted smaller. If the system rigidity is relatively small or the speed fluctuates largely, the speed gain should be adjusted larger.

3) Adjustment of the speed integration time constant

When the gain of the speed loop is increased, the speed integration time constant should be increased at the same time. Similarly, when the gain of the speed loop is decreased, the speed integration time constant should be decreased at the same time.

4) Adjustment of the ACC/DEC time

If the speed varies violently during starting, it may cause large impulse or even overcurrent. At this time we adjust the ACC time to smoothen the speed rise. Similarly, we can adjust the DEC time to smoothen the speed fall during stopping.

5) S curve ACC/DEC adjustment

If the requirement for smooth variation of speed can not be met by adjusting the ACC/DEC time, we can adjust the S curve ACC/DEC time to make it change more smoothly.

6) Adjustment of the speed smoothing filter

In the case where the analog speed command is inputted, we can adjust the speed smoothing

filter time constant to make the speed change smoothly.

7) Adjustment of speed feed-forward

If the speed follow-up performance is still poor after above parameter adjustment, we can adjust the torque feed-forward gain to improve the speed follow-up performance. It should be noted however that too large torque feed-forward gain may affect the stability of the system.

8) Adjustment of speed filter

The performance of the speed loop can be improved by adjusting FP2.04/FP2.09 and FP2.03/FP2.08.

9) Adjustment of trap wave filtering

See chapter 7.2.

10) Frequency division of the feedback pulse output

If the feedback pulse of the encoder needs to be outputted, the frequency division coefficient of pulse output can be used to change the frequency of the output pulse.

7.1.3 Adjustment of the gain of the torque loop

The torque control block diagram of the SV-DB100series servo drive is shown in the figure below. The gain parameters that can be adjusted in the torque mode are marked out on the block diagram.

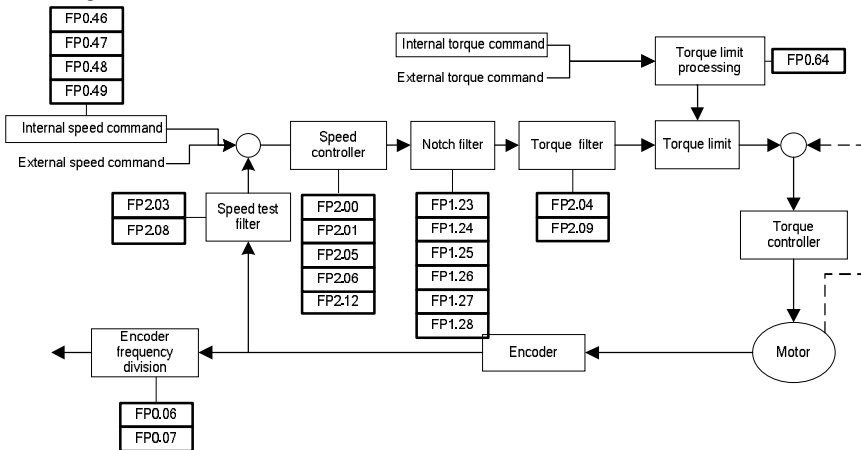

Fig. 7-3 Block diagram of torque control

The general procedures for parameter adjustment in the torque mode are:

1) Initial setting of the parameters

The defaults of the parameters can be recovered by the default parameter recovering operation (see chapter 5.2.4 for details).

2) Adjustment of the torque smoothing filter

In the case the analog torque command is inputted, we can adjust the torque smoothing filter time constant to make the torque change smoothly.

3) Frequency division of the feedback pulse output

If the feedback pulse of the encoder needs to be outputted, the frequency division coefficient of pulse output can be used to change the frequency of the output pulse.

7.2 Suppression of mechanical resonance

The mechanical system has a certain resonant frequency. If the response speed of the servo is improved, the system may resonate (oscillation and abnormal noise) near the mechanical resonant frequency. The resonance of the mechanical system can be effectively suppressed by setting the parameters of the trap wave filters.

The trap wave filters achieve the goal of suppressing mechanical resonance by decreasing the gain of certain frequency. We can set the frequency to be suppressed as well as the suppression extent with relevant parameters.

This servo drive has two trap wave filters which can be set with FP1.23, FP1.24, FP1.25 and FP1.26, FP1.27, FP1.28 respectively. The position of the trap wave filters in the speed loop is as shown in Fig. 7-2.

Note: for the servo system, the trap wave filter is a kind of lagging factor. Therefore, incorrect setting of the trap wave filters or too large suppression extent may strengthen vibration sometimes.

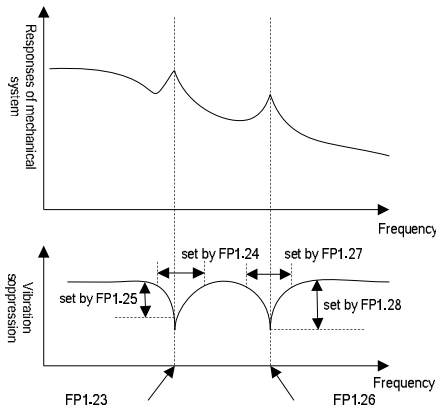

Fig. 7-4 Schematic diagram of setting of the trap wave filters

7.3 Gain switching function

Gain switching operation is performed through internal data or external signal:

- 1) Can switch to lower gain to suppress vibration in the state when the motor is stopped (the servo is locked);
- 2) Can switch to higher gain to shorten the positioning time in the state the motor is stop;
- 3) Can switch to high gain to obtain better command follow-up performance in the state when the motor is running.
- 4) Can switch between different gain settings through external signal according to the conditions of load, equipment and so on.

Here demonstrating how to improve the response performance in the position control mode by the gain switching function: in order to get better response performance and make the servo motor position quickly, we set $FP2.21=1$, $FP2.22=5$, $FP2.25=30.0$. At this time, when no pulse is inputted, the system uses the 1st gain for adjustment. After the pulse command is inputted, it smoothly switches to the 2nd gain. After the command input stops, in 2ms, if the speed falls below the setting of $FP2.25$, it will switch to the 1st gain. The whole process is shown in the figure below:

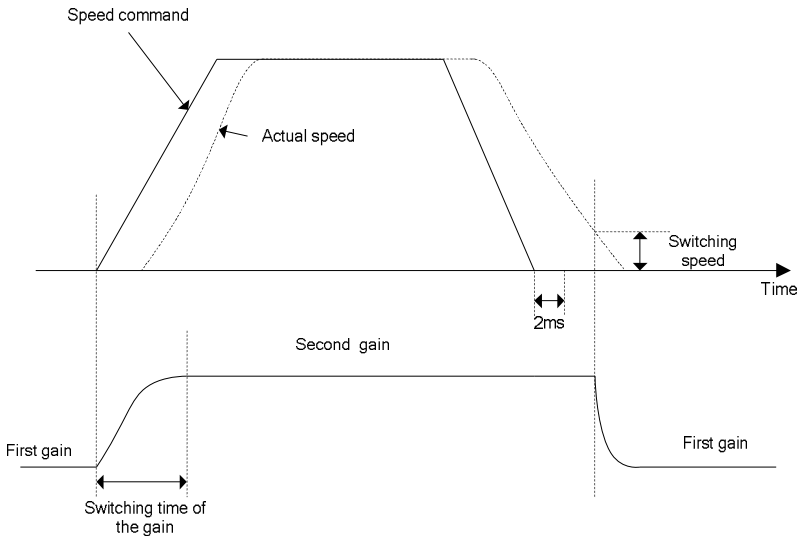

Fig. 7-5 Schematic diagram of gain switching

During positioning, generally, the speed integration function in running state of the motor can be deactivated to raise the gain and thus improve the response performance.

While after it has stopped, the gain to suppress the motor vibration can be decreased.

8 Communication function

8.1 General

The servo drive is provided with two types of communication interfaces: RS485 and RS232. The PC or NC can realize asynchronous serial semiduplex communication with 32 servo drives simultaneously through RS485 interface. The communication function has realized the following functions:

- ◆ Read/write the function parameters of the servo drives
- ◆ Monitor the operating state of the servo drives
- ◆ Form a multi-axis control system

8.2 Topological structure

SV-DB100 series servo drive is connected in the “Single Master Multi-slave” control network with RS232/RS485 bus.

8.2.1 Communication with single set

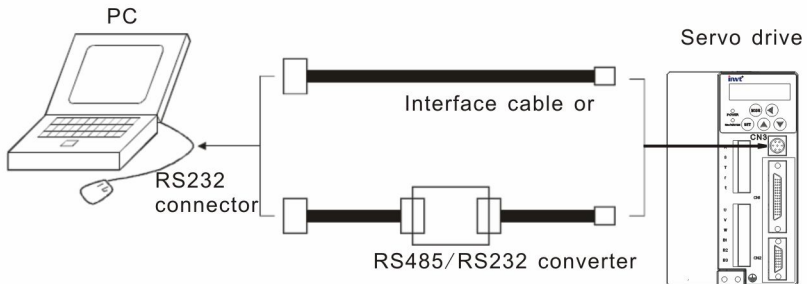

8.2.2 Communication with multiple sets

Can run and operate 32 servo drives on one bus.

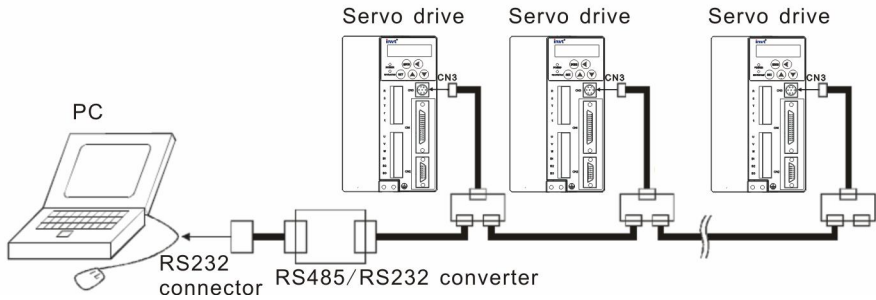

8.3 Communication protocol

The SV-DB100 series servo drive is provided with two types of communication interfaces: RS485 and RS232. It adopts international standard Modbus communication protocol to perform master-slave communication. The user can realize centralized control through PC/PLC, upper control PC, etc. (set the control command, running frequency of the servo drives, modify relevant function codes, monitor and control the operating state and fault information of the servo drives and so on) to adapt specific application requirements.

8.3.1 Protocol Content

The Modbus serial communication protocol defines the frame content and usage format in asynchronous transmission which includes: master polling, and the format of the broadcast frame and the slave answering frame. The frame of the master includes: the slave address (or the broadcast frame), commands, digit and error checkout. The slave answering also applies the same structure: action confirmation, digit returning and error checkout. If there is a mistake during the frame receiving of the slave or the slave can not finish the action which the master requires, it will respond an error frame to the master as a response.

8.3.2 Protocol instructions

The communication protocol of the SV-DB100 series servo drives is an asynchronous serial Master-Slave communication protocol. The master is the only device in the network to build up the protocol (named as inquiry/command), while the other devices (the slaves) can respond to or do action to the inquiry/command of the master through providing digits. The master in this manual means PC, industrial control devices and PLC. The slaves mean the servo drives and other control devices with the same communication protocol. The master can communicate

with a certain salve, as well as, send broadcast message to all slaves. For the separately-visiting inquiry/command of the master, the slave should return a message as the response. While for the broadcast message, the salve needs not to do so.

8.3.3 Communication Protocol Format

Modbus protocol supports both RTU and ASCII mode. The user can select whatever they prefer as well as the serial communication parameters, such as, the baud rate and the checkout means. All the devices on the same Modbus network should select the same transmission mode and serial parameters during configuring each control devices.

8.3.3.1 ASCII mode

When the control device is set as ASCII communication mode on the Modbus network, every 8bit byte in the message is sent as two ASCII characters. The advantage of this mode is the time interval of byte sending can achieve 1m without mistakes.

Table 8-1: The message frame in ASCII mode

The start bit	Device address	Command code	Data	LRC checkout	The tailed
1 character	2 characters	2 characters	n characters	2 characters	2 characters

As table 1 showed, in the message of ASCII mode, the start bit is ":" (ASCII code 3AH) and the tailed is the line break (ASCII code 0DH, 0AH). The device on the network is detecting ":" during the transmission. Each device decodes the next address field when receiving a ":" to estimate the owner. The device corresponds to the address field continues to receive other field until the line break appears. Except for the start bit and the tailed, the transmitting characters used in other fields are 0.....9, A.....F (hex) and the ASCII codes are also used to express characters. In the ASCII mode, LRC is used in the message to check the error.

8.3.3.2 RTU mode

When the control device is set as RTU mode, every 8bit byte in the message frame includes two 4Bit hex characters.

Table 8-2: The message frame in RTU mode

The start bit	Device address	Command code	Data	LRC checkout	The tailed
T1-T2-T3-T4	8Bit	8Bit	n 8Bit(s)	16Bit	T1-T2-T3-T4

The Modbus minimum idle time between frames should be no less than 3.5 bytes. The network device is detecting, even during the interval time, the network bus. When the first field (the address field) is received, the corresponding device decodes next transmitting character. When the interval time is at least 3.5 byte, the message ends.

The whole message frame in RTU mode is a continuous transmitting flow. If there is an interval time (more than 1.5 bytes) before the completion of the frame, the receiving device will renew the uncompleted message and suppose the next byte as the address field of the new message. As such, if the new message follows the previous one within the interval time of 3.5 bytes, the receiving device will deal with it as the same with the previous message. If these two phenomena all happen during the transmission, the CRC will generate a fault message to respond to the sending devices.

When the control device is set as RTU communication mode (remote terminal unit), every 8bit byte in the message includes two 4Bit hex characters. Compared with ACSII mode, this mode can send more data at the same baud rate.

8.3.4 Command code and the communication data instructions

8.3.4.1 Command code: 03H

Function: read N words (can read no more than 16 words continuously).

For example, the servo drive with the slave address of 01H, if its starting address is 0601H, read 2 words continuously, and then the structure of the frame is:

Table 8-3 The RTU master device request command

START	T1-T2-T3-T4 (transmission time of 3.5 bytes)
ADDR	01H
CMD	03H
High byte of start address	06H
Low byte of start address	01H
High byte of data number	00H
Low byte of data number	02H
Low byte of CRC CHK	95H
High byte of CRC CHK	43H
END	T1-T2-T3-T4 (transmission time of 3.5 bytes)

Table 8-4 The RTU slave device reply

START	T1-T2-T3-T4 (transmission time of 3.5 bytes)
ADDR	01H
CMD	03H
Returned byte number	04H
Higher byte of 0004H	00H
Low byte of 0004H	00H
High byte of 0005H	00H
Low byte of 0005H	00H

Low byte of CRC CHK	FAH
High byte of CRC CHK	33H
END	T1-T2-T3-T4 (transmission time of 3.5 bytes)

Table 8-5 The ASCII master device request command

START	':'
ADDR	'0'
	'1'
CMD	'0'
	'3'
High byte of start address	'0'
	'6'
Low byte of start address	'0'
	'1'
High byte of data number	'0'
	'0'
Low byte of data number	'0'
	'2'
LRC CHK Hi	'F'
LRC CHK Lo	'3'
END Lo	CR
END Hi	LF

Table 8-6 The ASCII slave master device reply

START	':'
ADDR	'0'
	'1'
CMD	'0'
	'3'
Returned byte number	'0'
	'4'
Higher byte of 0401H	'0'
	'0'
Low byte of 0401H	'0'
	'0'
High byte of 0402H	'0'

	'0'
Low byte of 0402H	'0'
	'0'
LRC CHK Lo	'8'
LRC CHK Hi	'F'
END Lo	CR
END Hi	LF

8.3.4.2 Command code: 06H

Function: write one word (word)

For example, write 5000(1388H) into address 002EH, slave device address 02H. And then the structure of the frame is:

Table 8-7 The RTU master device request command

START	T1-T2-T3-T4 (transmission time of 3.5 bytes)
ADDR	02H
CMD	06H
High byte of data address	00H
Low byte of data address	2EH
High byte of write content	13H
Low byte of write content	88H
Low byte of CRC CHK	E4H
High byte of CRC CHK	A6H
END	T1-T2-T3-T4 (transmission time of 3.5 bytes)

Table 8-8 The RTU slave device reply command

START	T1-T2-T3-T4 (transmission time of 3.5 bytes)
ADDR	02H
CMD	06H
High byte of data address	00H
Low byte of data address	2EH
High byte of write content	13H
Low byte of write content	88H
Low byte of CRC CHK	E4H

High byte of CRC CHK	A6H
END	T1-T2-T3-T4 (transmission time of 3.5 bytes)

Table 8-9 The ASCII master device request command

START	‘:’
ADDR	‘0’
	‘2’
CMD	‘0’
	‘6’
High byte of data address	‘0’
	‘0’
Low byte of data address	‘2’
	‘E’
High byte of write content	‘1’
	‘3’
Low byte of write content	‘8’
	‘8’
LRC CHK Hi	‘2’
LRC CHK Lo	‘F’
END Lo	CR
END Hi	LF

Table 8-10 The ASCII slave master device reply

START	‘:’
ADDR	‘0’
	‘2’
CMD	‘0’
	‘6’
High byte of data address	‘0’
	‘0’
Low byte of data address	‘2’
	‘E’
High byte of write content	‘1’
	‘3’
Low byte of write content	‘8’

	'8'
LRC CHK Hi	'2'
LRC CHK Lo	'F'
END Hi	CR
END Lo	LF

8.3.4.3 Command code: 08H

Function: diagnosis

Table 8-11 Meaning of sub-function codes

Sub-function Code	Description
0000	Return to inquire information data

For example: The inquiry information string is same as the response information string when the loop detection to address 01H of driver is carried out.

Table 8-12 The RTU request command

START	T1-T2-T3-T4 (transmission time of 3.5 bytes)
ADDR	01H
CMD	08H
High byte of sub-function code	00H
Low byte of sub-function code	00H
High byte of data content	12H
Low byte of data content	ABH
Low byte of CRC	ADH
High byte of CRC	14H
END	T1-T2-T3-T4 (transmission time of 3.5 bytes)

Table 8-13 The RTU reply command

START	T1-T2-T3-T4 (transmission time of 3.5 bytes)
ADDR	01H
CMD	08H
High byte of sub-function code	00H
Low byte of sub-function code	00H
High byte of data content	12H
Low byte of data content	ABH
Low byte of CRC	ADH
High byte of CRC	14H

END	T1-T2-T3-T4 (transmission time of 3.5 bytes)
-----	--

Table 8-14 The ASCII request command

START	':'
ADDR	'0'
	'1'
CMD	'0'
	'8'
High byte of sub-function code	'0'
	'0'
Low byte of sub-function code	'0'
	'0'
High byte of data content	'1'
	'2'
Low byte of data content	'A'
	'B'
LRC CHK Hi	'3'
LRC CHK Lo	'A'
END Hi	CR
END Lo	LF

Table 8-15 The ASCII reply command

START	':'
ADDR	'0'
	'1'
CMD	'0'
	'8'
High byte of sub-function code	'0'
	'0'
Low byte of sub-function code	'0'
	'0'
High byte of data content	'1'
	'2'
Low byte of data content	'A'
	'B'

LRC CHK Hi	'3'
LRC CHK Lo	'A'
END Hi	CR
END Lo	LF

8.3.5 Error checkout of the communication frame

The error checkout of the frame can be divided into two parts: the bit checkout of the byte and the whole data checkout of the frame (CRC check or LRC check).

8.3.5.1 Bit checkout of the byte

The user can select different bit checkouts or non-checkout, which impacts the check bit setting of each byte.

The definition of even checkout: add an even check bit before the data transmission to illustrate the number of "1" in the data transmission is odd number or even number. When it is even, the check byte is "0", otherwise, the check byte is "1". This method is used to stabilize the parity of the data.

The definition of odd checkout: add an odd check bit before the data transmission to illustrate the number of "1" in the data transmission is odd number or even number. When it is odd, the check byte is "0", otherwise, the check byte is "1". This method is used to stabilize the parity of the data.

For example, when transmitting "11001110", there are five "1" in the data. If the even checkout is applied, the even check bit is "1"; if the odd checkout is applied; the odd check bit is "0". The even and odd check bit is calculated on the check bit position of the frame. And the receiving devices also carry out even and odd checkout. If the parity of the receiving data is different from the setting value, there is an error in the communication.

8.3.5.2 CRC CRC check

The checkout uses RTU frame format. The frame includes the frame error detection field which is based on the CRC calculation method. The CRC field is two bytes, including 16 figure binary values. It is added into the frame after calculated by transmitting device. The receiving device recalculates the CRC of the received frame and compares them with the value in the received CRC field. If the two CRC values are different, there is an error in the communication.

During CRC, 0*FFFF will be stored. And then, deal with the continuous 6-above bytes in the frame and the value in the register. Only the 8Bit data in every character is effective to CRC, while the start bit, the tailed and the odd and even check bit is ineffective.

The calculation of CRC applies the international standard CRC checkout principles. When the user is editing CRC calculation, he can refer to the relative standard CRC calculation to write the required CRC calculation program.

Here provided a simple function of CRC calculation for the reference (programmed with C language):

```

unsigned int crc_cal_value(unsigned char *data_value,unsigned char data_length)
{
int i;
unsigned int crc_value=0xffff;
while(data_length--)
{  crc_value^=*data_value++;
    for(i=0;i<8;i++)
    {
if(crc_value&0x0001)crc_value=(crc_value>>1)^0xa001;
    else crc_value=crc_value>>1;
    }    }
return(crc_value);
}

```

In ladder logic, CKSM calculated the CRC value according to the frame with the table inquiry. The method is advanced with easy program and quick calculation speed. But the ROM space the program occupied is huge. So use it with caution according to the program required space.

8.3.5.3 LRC check

The LRC check is the value adding from Address to Date Content. For example, the LRC check of the 8.3.4.2 communication information is $0 \times 02 + 0 \times 06 + 0 \times 01 + 0 \times 09 + 0 \times 13 + 088 = 0AD$, and then complementary code = 0×53 .

8.3.6 Address definition of communication data

This chapter is the address definition of communication data used to control the running of the servo drives, acquire the state information of the servo drives and set relevant function parameters of the servo drives and so on.

The servo drive has 4 groups of function codes: FP0.XX, FP1.XX, FP2.XX, FP3.XX, FP4.XX, FP9.00 and rXX.XXX. The first 3 groups of function codes are not only readable but also can be modified through communication. rXX.XXX is readable. The writing is invalid.

The address of the function codes are composed of two 8-bit, expressed with the hexadecimal system. The first 8-bit indicates the group number of the function codes: FP0 group is 00H, FP1 group is 01H, FP2 group is 02H, FP3 group is 03H, FP4 group is 04H, FP9 group is 05H, rXX group is 06H. The last 16-bit indicates the hexadecimal expression of the serial number of the function code. For examples, the address of function code FP0.25 is 0019H and the address of FP4.31 is 041FH.

Table 8-6 Special function codes

Function description	Address definition	Explanation of data meaning	R/W characteristics
Communication control command	1000H	0000H: Jog end	W
		0001H: Jog start	
		0002H: FWD jog start	
		0003H: REV jog start	
		0004H FWD jog end	
		0005H: REV jog end	
Servo state	1001H	0001H: FWD running	R
		0002H: REV running	
		0003H: Servo drive standby	
		0004H: in fault	
EEPROM writing	1002H	0002H: parameter default recovering	W
Control quantity	1003H	See description of Pd.18 for the arrangement sequence of the digital quantities. In which, 3 signals – EMG, PSL and RVL – cannot be controlled through communication. Bit 13 is the communication control enabling bit.	W/R
Data storage control	1004H	Storage step length (unit: cycle number of the carrier wave)	W/R
	1005H	Storage manner	W/R
		0000H: store only 1 screen 0001H: cyclic storage	
	1006H	Storage command	W/R
		0000H: end storage 0001H: start storage	
1008H	Channel 1 function code selection	W/R	
1009H	Channel 2 function code selection	W/R	

Function description	Address definition	Explanation of data meaning	R/W characteristics
	2000H	Channel 1 data starting address	R
	3000H	Channel 2 data starting address	R
Particular address	0700H	Internal speed/speed limit 1 (FP0.46) higher 16 bits	W/R
	0701H	Internal speed/speed limit 2 (PA.10) Higher 16 bits	W/R
	0702H	Internal speed/speed limit 3 (Pc.10) Higher 16 bits	W/R
	0703H	Internal speed/speed limit 4 (Pc.11) Higher 16 bits	W/R
	0704H	Lower 16 bits of speed feedback	R
	0705H	Higher 16 bits of speed feedback	R

8.3.7 Fault Responses

The slave uses functional code fields and fault addresses to indicate it is a normal response or some error occurs (named as objection response). For normal responses, the slave shows corresponding function codes, digital address or sub-function codes as the response. For objection responses, the slave returns a code which equals the normal code, but the first byte is logic 1.

For example: when the master sends a message to the slave, requiring it to read a group of address data of servo device function codes, there will be following function codes:

0 0 0 0 0 1 1 (Hex 03H)

For normal responses, the slave responds the same codes, while for objection responses, it will return:

1 0 0 0 0 1 1 (Hex 83H)

Besides the function codes modification for the objection fault, the slave will respond a byte of abnormal code which defines the error reason.

When the master receives the response for the objection, in a typical processing, it will send the message again or modify the corresponding order.

Table 8-17 Meaning of error code

Modbus abnormal code		
Code	Name	Meaning
01H	Illegal function	Receiving function codes from the upper devices is not allowable. This may because these function codes can only

Modbus abnormal code		
Code	Name	Meaning
		be applied to new devices or the slave device is dealing with this requirement in a wrong situation.
02H	Illegal digital address	For servo drives, the requirement digital address is not allowable; especially the mix of the register address and transmitting byte numbers is invalid.
03H	Illegal digital value	The digital value received is beyond the range of address parameters, leading the parameter modification invalid.
11H	Check error	In the frame message sent by the upper devices, if the CRC check bit of RTU format or the LRC check bit of ASCII format is different from the check number calculated by the below device, an check error will be reported.

9 Fault processing

9.1 Meanings of the fault alarm codes and countermeasures

No.	Code	Name	Causes	Countermeasures
1	Er-EEP	EEPROM fault	1. EEPROM is damaged	1. Replace the drive
2	Er-Ec1	Encoder line break fault 1	1. The encoder is not connected 2. The encoder connector becomes loose 3. The line of one of the U, V, W phases of the encoder signal cable is broken	1. Connect the encoder 2. Check the encoder connector or replace the encoder cable 3. Replace the encoder cable
3	Er-Ec2	Encoder fault 2	1. Reversed A/B phase of the encoder 2. The line of one of the A, B, Z phases of the encoder signal cable is broken	1. Check that the phases of the encoder are wired correctly 2. Replace the encode cable
4	Er-ITE	Current test fault	1. The current sensor or test circuit is abnormal 2. Powered on when the motor shaft is in a non-stationary state	1. Replace the drive 2. Never power on when the motor shaft is rotating
5	Er-oc1	Hardware overcurrent fault	1. U, V, W phases of the motor are connected reversely 2. Inappropriate parameters cause system divergence 3. Too short ACC/DEC time during starting/stopping 4. Too large instant load	1. Check that the phases of the motor cable are connected correctly 2. Adjust the loop parameters to stabilize the system. Adjust the value of FP0.12 smaller 3. Set the ACC/DEC time appropriately longer 4. Replace with a drive of higher power

No.	Code	Name	Causes	Countermeasures
6	Er-oc2	Line-to-ground short circuit fault	1. One of U, V, W phases of the motor cable is shorted to the ground	Replace the motor cable or test if the motor insulation is aged
7	Er-ou	Overtoltage fault	1. The grid voltage is high 2. The braking resistor is not connected 3. The braking transistor is damaged 4. Too short ACC/DEC time during starting/stopping	1. Test the input voltage of the grid 2. Check if the built-in braking resistor shorting wiring becomes loose, or check if the built-in braking resistor is damaged 3. Replace the drive 4. Set the ACC/DEC time longer
8	Er-uu	Undervoltage fault of the main bus	1. The grid voltage is low 2. The powering-up snubber relay has not picked up	1. Test the input voltage of the grid 2. Replace the drive
9	Er-uu1	Undervoltage fault of the control bus	1. The grid voltage is low 2. The powering-up snubber relay has not picked up	1. Test the input voltage of the grid 2. Replace the drive
10	Er-oL	Overload fault	1. Run overload for a long period of time 2. The load is too heavy in a short period of time	1. Replace with the drive and motor of higher power 2. Replace with the drive and motor of higher power
11	Er-LnE	Line abnormality fault	1. U, V, W phases of the motor are connected reversely	1. Check that the phases of the motor cable are connected correctly
12	Er-oS	Overspeed fault	1. The motor speed is too high 2. Overspeed of the motor.	1. Replace with a motor of higher speed or check the parameter settings

No.	Code	Name	Causes	Countermeasures
			U, V, W phases of the motor are connected reversely	2. Check that the phases of the motor cable are connected correctly
13	Er-oH1	Drive overtemperature fault	1. The temperature of the IGBT module of the drive is too high	1. Improve the ventilation or replace with a servo drive of higher power
14	Er-oE	Over-pulse fault	1. Number of the retention pulses is too large	1. Set the gain parameters of the position loop higher or set the position feed-forward gain higher
15	Er-cTE	Communication fault	1. Too high communication fault rate 2. Communication disconnecting	1. Try to decrease the communication interference 2. Check the connection of the communication cable
16	Er-oT	Write/read overtime fault	1. Overtime when reading/writing EEPROM 2. Damaged EEPROM	1. Replace the drive 2. Replace the drive
17	Er-bcE	Brake overload fault	1. The power of the built-in braking resistor is relatively low 2. The power of the external braking resistor is relatively low	1. Connect an external braking resistor of higher power 2. Replace with a braking resistor of higher power
18	Er-iPo	IPM module fault	1. IPM module detects overcurrent or undercurrent	1. Adjust FP0.12 smaller to decrease the maximum output torque or replace with a drive of higher power
19	Er-dP	Power supply input phase loss	3-phase input power supply is phase loss or	Check the input voltage or the wire is loose or

No.	Code	Name	Causes	Countermeasures
			seriously uneven.	disconnected.
20	Er-INE	Inertia identification fault	1.Vibration in stopping exceeds 3.5s 2. Too short ACC time 3. The identification speed is below 150r/min	1.Improve the mechanical rigidity 2.Prolong FP1.07 3.Increase FP1.06
21	Er-DrE	Motor parameters matching fault	Wrong FP0.00 setting	Ensure the motor model and the drive model

9.2 Meanings of the warning codes

No.	Warning	Name	Description
1	AL-LT1	Forward travel limit warning	This warning signal is generated when forward travel is limited (PSL terminal disconnects)
2	AL-LT2	Reverse travel limit warning	This warning signal is generated when reverse travel is limited (RVL terminal disconnects)
3	AL-EST	Emergency stop warning	This warning signal is generated when the emergency stop button acts (EMG terminal disconnects)
4	AL-Pof	Low voltage of the main circuit warning	This warning signal is generated when the bus voltage is too low.
5	AL-cTE	Communication abnormality warning	In the case of communication overtime or abnormal, if Pc.26=1, this warning signal is generated.

See chapter 5.2.6 for the detailed method to clear the alarm or warning display when a fault alarm or warning occurs.

Appendix A List of function parameters

P – position mode; S – speed mode; T – torque mode.

The function codes prefixed with sign “*” indicate the setting of these parameters can only take effect after the system resets, restarts, or control circuit is powered off and repowered.

Function code	Name	Unit	Range	Default	Mode
FP0 Basic control					
FP0.00	Matching motor selection	-	200~599	-	PST
FP0.03*	Mode selection	-	0~6	0	PST
FP0.04	Internal servo enabling	-	0~1	0	PST
FP0.05	Jog speed	r/min	0.0~1000.0	200.0	PST
FP0.06*	Numerator of the frequency division coefficient of encoder pulse output	-	0~30000	10000	PST
FP0.07*	Denominator of the frequency division coefficient of encoder pulse output	-	0~30000	0	PST
FP0.11	Max torque limit	%	0.0~300.0	300.0	PST
FP0.12	Internal torque limit	%	0.0~300.0	-	PS
FP0.13	Power of the external braking resistor	W	0~1500	0	PST
FP0.14	Resistance of the external braking resistor	Ω	1~100	1	PST
FP0.15*	Default monitoring parameters	-	0~37	0	PST
FP0.16	Parameter modification operation locking	-	0~1	0	PST
FP0.17	Communication EEPROM write selection	-	0~1	0	PST
FP0.23*	Pulse input	-	0~2	0	P
FP0.24*	Pulse input direction	-	0~1	0	P

Function code	Name	Unit	Range	Default	Mode
	reversing				
FP0.25	Numerator of the 1 st electronic gear	-	1~65535	1	P
FP0.26	Denominator of the 1 st electronic gear	-	1~65535	1	P
FP0.27	Numerator of the 2 nd electronic gear	-	1~65535	1	P
FP0.28	Numerator of the 3 rd electronic gear	-	1~65535	1	P
FP0.29	Numerator of the 4 th electronic gear	-	1~65535	1	P
FP0.30	Denominator of the 2 nd electronic gear	-	1~65535	1	P
FP0.31	Denominator of the 3 rd electronic gear	-	1~65535	1	P
FP0.32	Denominator of the 4 th electronic gear	-	1~65535	1	P
FP0.33	Position command filter time	ms	0.0~1000.0	0.0	P
FP0.40	Speed command/speed limit selection	-	0~1	0	ST
FP0.42	Speed command input gain	(r/min)/v	10~1000	500	ST
FP0.44	Speed command filter time	ms	0.0~1000.0	0.0	S
FP0.45	Dead zone of analog VA	V	0.000~2.000	0.000	ST
FP0.46	Internal speed/speed limit 1	r/min	-6000.0~6000.0	100.0	ST
FP0.47	Internal speed/speed limit 2	r/min	-6000.0~6000.0	200.0	ST
FP0.48	Internal speed/speed limit 3	r/min	-6000.0~6000.0	500.0	ST
FP0.49	Internal speed/speed limit 4	r/min	-6000.0~6000.0	1000.0	ST
FP0.54	ACC time	ms	0~20000	0	S
FP0.55	DEC time	ms	0~20000	0	S

Function code	Name	Unit	Range	Default	Mode
FP0.56	S curve ACC time	ms	0~1000	0	S
FP0.57	S curve DEC time	ms	0~1000	0	S
FP0.58	Stopping method	-	0~1	0	S
FP0.60	Torque command/torque limit selection	-	0~1	0	PST
FP0.62	Torque command input gain	%/V	10~300	10	PST
FP0.64	Torque command filter time	ms	0.0~1000.0	0.0	T
FP0.65	Dead zone of analog TA	V	0.000~2.000	0.000	PST
FP0.66	Internal torque command	%	-250.0~250.0	10.0	T
FP1 Self-turning control					
FP1.02	Rotational inertia ratio	%	0~10000	200	PST
FP1.03	Machine rigidity setting	-	0~31	13	PST
FP1.04	Inertia identification switch	-	0~1	0	P
FP1.05	Inertia identification operation	-	0~3	0	P
FP1.06	Mechanical movement	r	0.5~10.0	1.5	P
FP1.07	Identification of inertia acceleration time constant	ms	2~200	2	P
FP1.20	Resonance frequency test valid	-	0~1	0	PST
FP1.21	1 st mechanical resonance frequency	Hz	0.0~3000.0	0.0	PST
FP1.22	2 nd mechanical resonance frequency	Hz	0.0~3000.0	0.0	PST
FP1.23	1 st trap wave center frequency	Hz	50.0~3000.0	3000.0	PST
FP1.24	1 st trap wave width	Hz	1.0~1000.0	50.0	PST
FP1.25	1 st trap wave depth	%	0.00~1.00	0.00	PST

Function code	Name	Unit	Range	Default	Mode
FP1.26	2 nd trap wave center frequency	Hz	50.0~3000.0	3000.0	PST
FP1.27	2 nd trap wave width	Hz	1.0~1000.0	50.0	PST
FP1.28	2 nd trap wave depth	%	0.00~1.00	0.00	PST
FP2 Motor control					
FP2.00	1 st speed gain	Hz	0.1~3000.0	27.0	PST
FP2.01	1 st speed integration time constant	ms	0.1~1000.0	21.0	PST
FP2.02	1 st position gain	1/s	0.1~3000.0	48.0	P
FP2.03	1 st speed detection filter time	ms	0.00~100.00	0.00	PST
FP2.04	1 st torque filter	ms	0.00~25.00	0.84	PST
FP2.05	2 nd speed gain	Hz	0.1~3000.0	27.0	PST
FP2.06	2 nd speed integration time constant	ms	0.1~1000.0	1000.0	PST
FP2.07	2 nd position gain	1/s	0.1~3000.0	57.0	P
FP2.08	2 nd speed detection filter time	ms	0.00~100.00	0.05	PST
FP2.09	2 nd torque filter	ms	0.00~25.00	0.84	PST
FP2.10	Speed feed-forward	%	0.0~100.0	30.0	P
FP2.11	Speed feed-forward filter time	ms	0.00~60.00	0.50	P
FP2.12	Torque feed-forward gain	%	0.0~100.0	0.0	PS
FP2.21	Gain switching selection	-	0~1	1	PST
FP2.22	Gain switching condition	-	0~5	0	PS
FP2.23	Gain switching time constant	ms	0~100	0	PS
FP2.25	Gain switching threshold	Pulse or r/min	0~5000/0~500.0	100/10.0	PS
FP2.47	Speed compensation threshold	pulse	0~20000	100	P
FP2.48	Speed compensation	r/min	0~500.0	0.0	P
FP3 I/O management					
FP3.00	Digital 1 input	-	0~11111	0	PST
FP3.20	Offset of AI VA	V	-2.000~2.000	0.000	ST

Function code	Name	Unit	Range	Default	Mode
FP3.23	Offset of AI TA	V	-2.000~2.000	0.000	PST
FP3.30	AO 1 selection	-	0`7	0	PST
FP3.31	Voltage gain of analog output 1	-	0~1000	500	PST
FP3.32	AO 2 selection	-	0~7	0	PST
FP3.33	Voltage gain of analog output 2	-	0~1000	500	PST
FP3.34	Offset of AO1	V	-2.00~2.00	0.00	PST
FP3.35	Offset of AO 2	V	-2.00~2.00	0.00	PST
FP3.40	Travel limit switch masking	-	0~1	0	PST
FP3.41	E-stop masking	-	0~1	0	PST
FP3.50	Range of position reaching	pulse	0~20000	100	P
FP3.54	Range of speed reaching	r/min	0.0~1000.0	30.0	S
FP3.55	Zero speed range	r/min	0.0~1000.0	50.0	PST
FP3.56	Locked time of servo after braking	ms	100~5000	100	PST
FP3.57	Braking delay time of the electromagnetic brake	ms	0~5000	1000	PST
FP4 Extension and application					
FP4.00*	Communication mode	-	0~1	1	PST
FP4.01	Local communication address	-	0~31	1	PST
FP4.02*	Communication baudrate selection	-	0~4	0	PST
FP4.04	Communication parity mode	-	0~17	0	PST
FP4.05	Communication response delay time	ms	0~200	0	PST
FP4.06	Communication overtime fault time	s	0.0~60.0	0.0	PST
FP4.07	Communication fault processing method	-	0~1	0	PST

Function code	Name	Unit	Range	Default	Mode
FP4.08	Communication response enabling	-	0~1	1	PST
FP4.09	Reserved	-	-	-	PST
FP4.30	Stopping mode selection	-	0~4	3	PST
FP4.31	Max. speed limit	r/min	0~6500.0	-	PST
FP4.32	Overspeed level	r/min	0~6553.5	-	PST
FP4.33	Pulse range for over position	10pulse	0~50000	2000	P
FP4.34	Brake overload detection enabling signal	-	0~1	1	PST
FP4.35	Input phase loss setting		0~1	0	PST
FP9 Factory parameters					
FP9.00	Factory password			100	PST

Function code	Name	Unit	Accuracy
r00.spd	Motor speed	r/min	0.1
r01.FP1	Lower 5 digits of feedback pulse accumulation	pulse	1
r02.FP2	Medium 5 digits of feedback pulse accumulation	pulse	1
r03.FP3	Higher 5 digits of feedback pulse accumulation	pulse	1
r04.rp1	Lower 5 digits of command pulse accumulation	pulse	1
r05.rp2	Medium 5 digits of command pulse accumulation	pulse	1
r06.rp3	Higher 5 digits of command pulse accumulation	pulse	1
r07.EP	Retention pulse	pulse	1
r08.An1	Analog speed command voltage	V	0.01
r09.An2	Analog torque command voltage	V	0.01
r10.ud1	Main circuit power bus voltage	V	0.1
r11.ud2	Control circuit power bus voltage	V	0.1
r12.cur	Effective value of current output current	A	0.01
r13.Tq	Current torque	%	1
r14.Tn	Drive module temperature	°C	0.1

Function code	Name	Unit	Accuracy
r15.Ld	Average load rate	%	1
r16.PoS	Position of the rotor relative to Z pulse	pulse	1
r17.inE	Inertia ratio of load	time	1
r18.oAL	The two previous fault alarm code	-	-
r19.AL	The previous fault alarm code	-	-
r20.ALc	Current fault alarm code	-	-
r21.in	Digital input state	-	-
r22.ou	Digital output state	-	-
r23.TT	Motor temperature	-	-
r24.uE1	DPS software version	-	-
r25.uE2	FPGA software version	-	-
r26.uuu	Encoder UVW feedback value	-	-
r27.iA	Instantaneous value of phase U output current	A	0.01
r28.ib	Instantaneous value of phase V output current	A	0.01
r29.iAF	Instantaneous value of U phase output current when a fault occurs	A	0.01
r30.ibF	Instantaneous value of phase V output current when a fault occurs	A	0.01
r31.udF	Bus voltage when a fault occurs	V	0.1
r32.Sn1	Drive serial No. 1	-	-
r33.Sn2	Drive serial No. 2	-	-
r34.Sn3	Drive serial No. 3	-	-
r35.Sn4	Drive serial No. 4	-	-
r36.Sn5	Drive serial No. 5	-	-
r37.Sn6	Drive serial No. 6	-	-

Appendix B Signal arrangement diagram

B.1 CN1 pin signal arrangement:

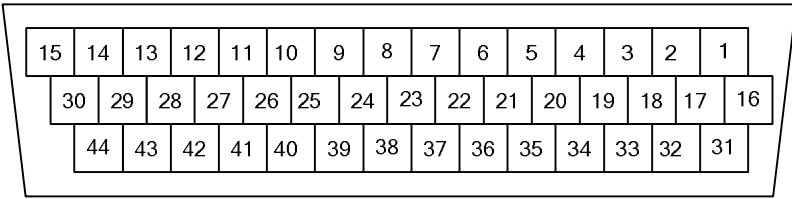

Pin arrangement of connector CN1

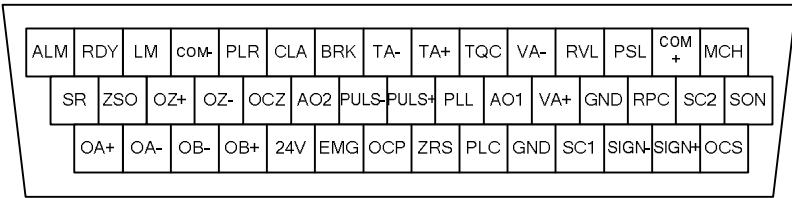

Signal arrangement of connector CN1

B.2 CN2 pin signal arrangement:

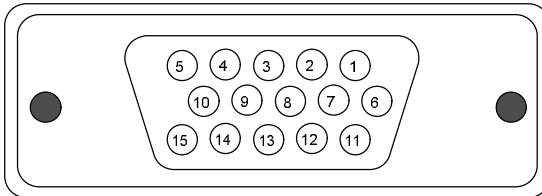

CN2 pin No.	CN2 pin No.	CN2 pin No.
1	V+	Black
2	W+	Brown
3	A+	Red
4	A-	Red and white
5	5V	Purple
6	U+	Orange
7	V-	Black and white
8	W-	Brown and white
9	B-	Blue
10	B+	Blue and white
11	U-	Orange and white
12	GND	Purple and white

CN2 pin No.	CN2 pin No.	CN2 pin No.
13	Z-	Green
14	Z+	Green and white
15	/	/

B.3 CN3 pin signal arrangement:

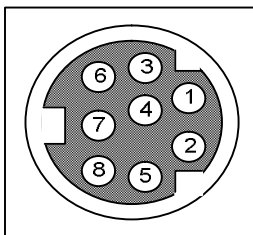

CN3 pin No.	1	2	3	4	5	6	7	8
Definition	RXD	GND	TXD	CANL	/	CANH	RS485-	RS485+

Appendix C Plug signal of servo motor

C.1 Plug of the motor

C.1.1 Below and including 750W:



Wire sequence of the motor				
No.	1	2	3	4
Color	Brown	Yellow and green	Black	Blue
Signal	W	PE	V	U

C.1.2 Above 750W:



Wire sequence of the motor				
No.	1	2	3	4
Color	Yellow and green	Blue	Black	Brown
Signal	PE	U	V	W

C.2 Plug of encoder wire

C.2.1 Below and including 750W:

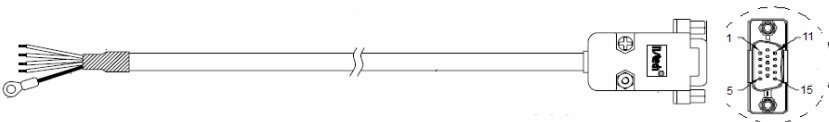

No.	Color	Signal
-----	-------	--------

No.	Color	Signal
1	V+	Black
2	W+	Brown
3	A+	Red
4	A-	Red and white
5	5V	Purple
6	U+	Orange
7	V-	Black and white
8	W-	Brown and white
9	B-	Blue
10	B+	Blue and white
11	U-	Orange and white
12	GND	Purple and white
13	Z-	Green
14	Z+	Green and white
15	/	/

C.2.2 Above 750W:



No.	Signal	Color
1	PE	Shield wires
2	5V	Purple
3	GND	Purple and white
4	A-	Red and white
5	B+	Blue and white
6	C+	Green and white
7	A+	Red
8	B-	Blue
9	C-	Green

No.	Signal	Color
10	U+	Orange
11	V+	Black
12	W+	Brown
13	U-	Orange and white
14	V-	Black and white
15	W-	Brown and white

Appendix D Wiring examples

D.1 Connection with Panasonic FPG-C32T

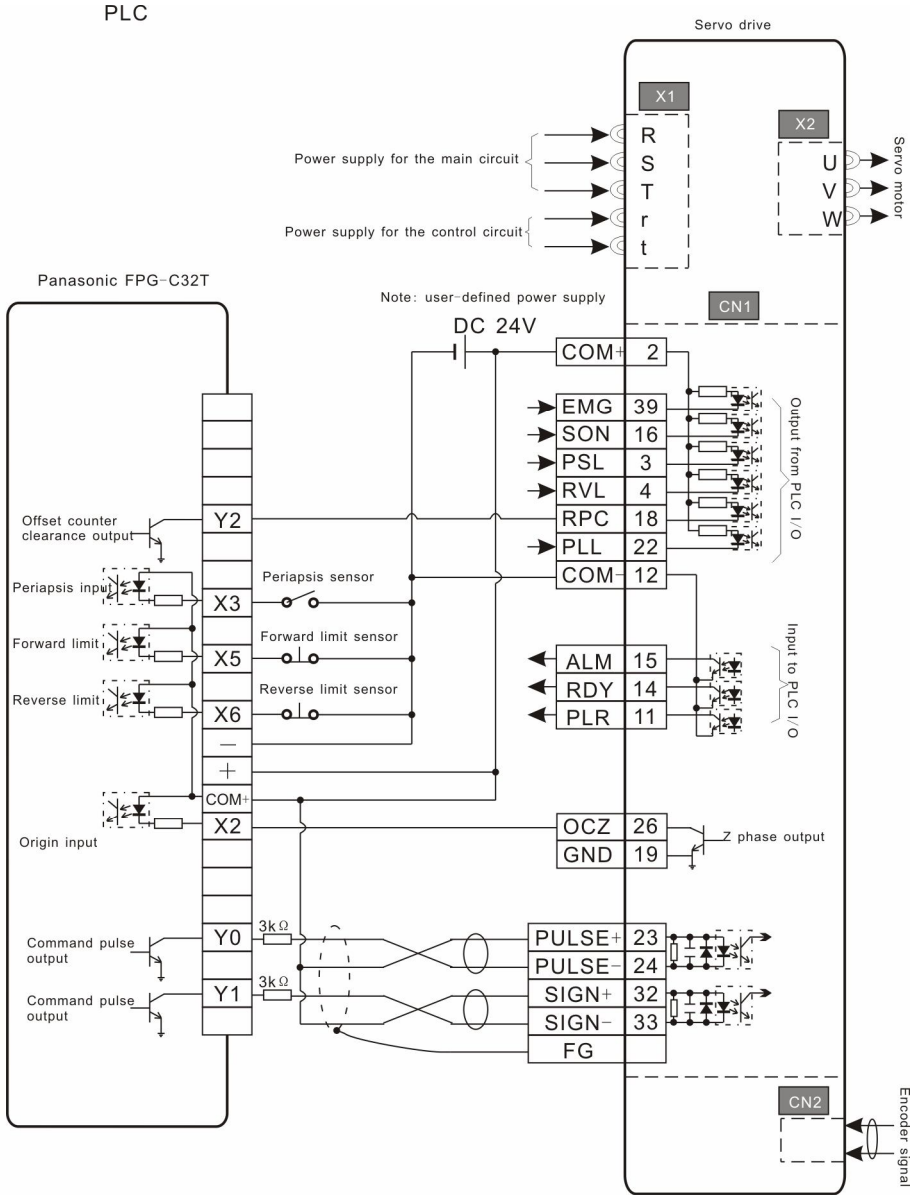

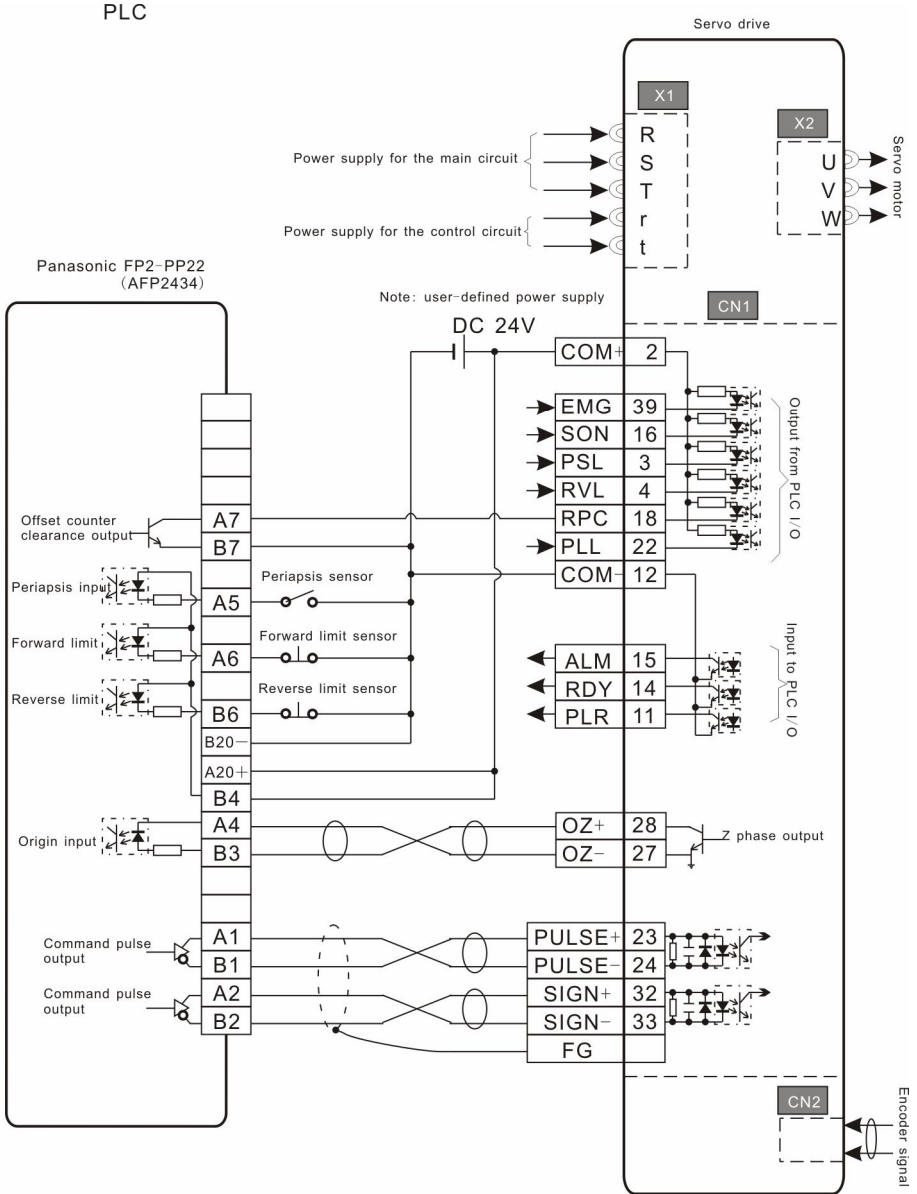

D.2 Connection with Panasonic FP2-PP22 (AFP2434)

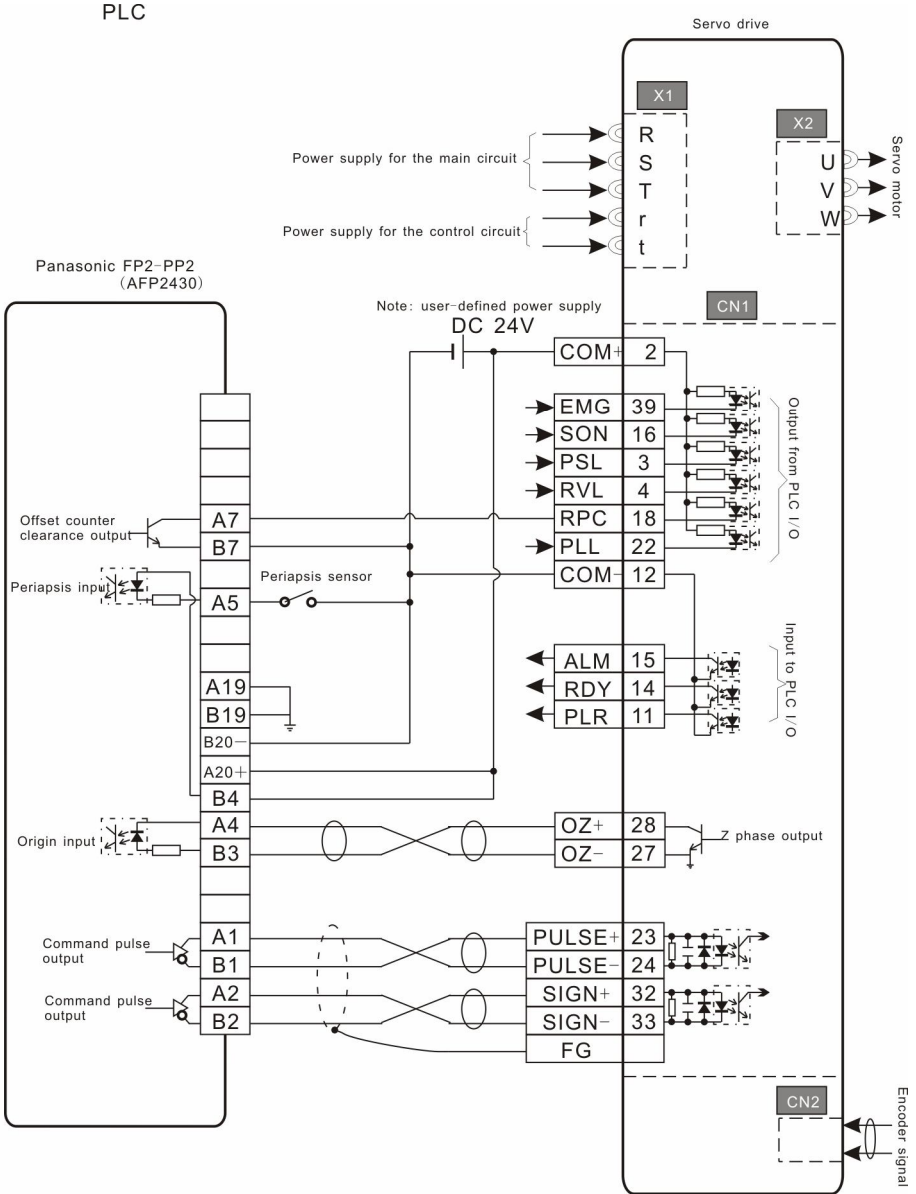

Note:  Is twisted shields.

D.3 Connection with Panasonic FP2-PP2 (AFP2430)



Note:  Is twisted shields.

D.4 Connection with Yokogawa PLC F3YP14-ON/F3YP18-ON

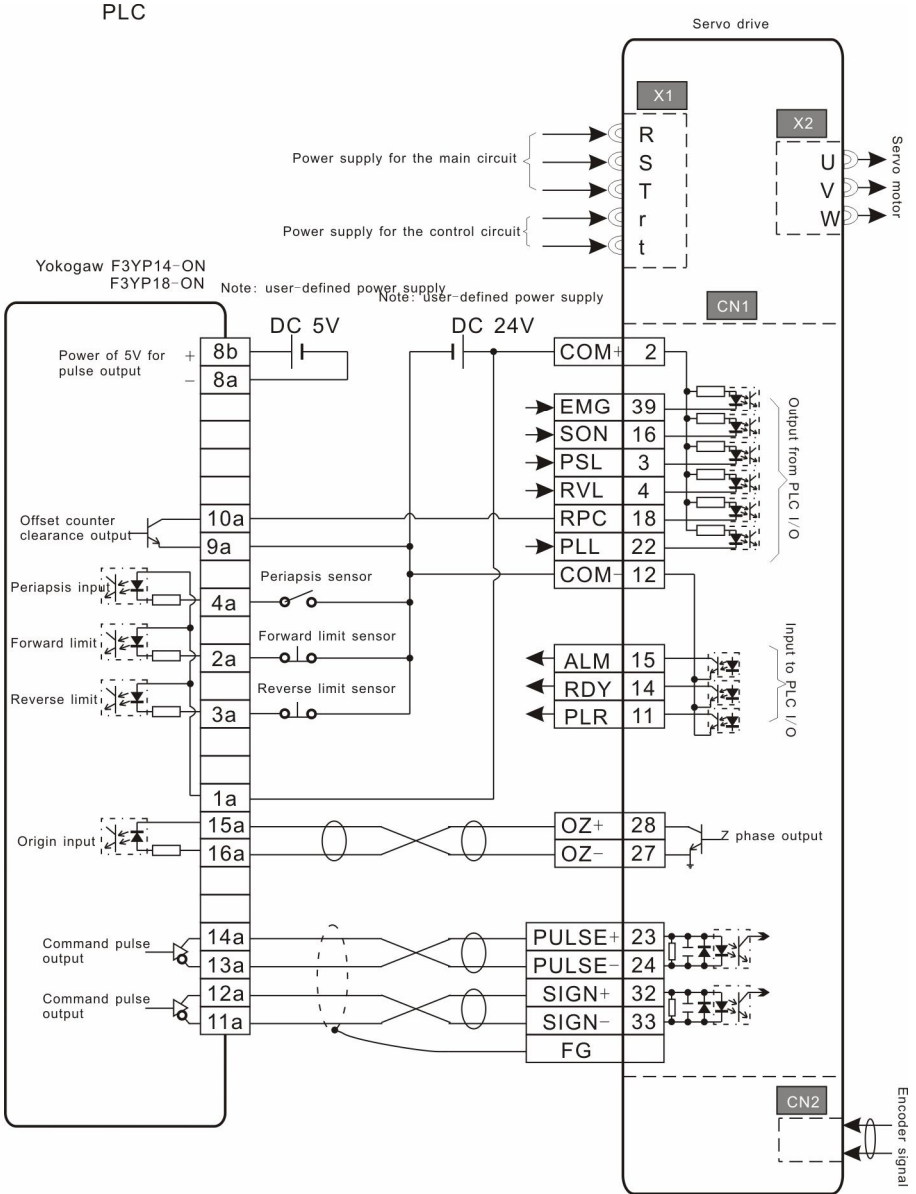

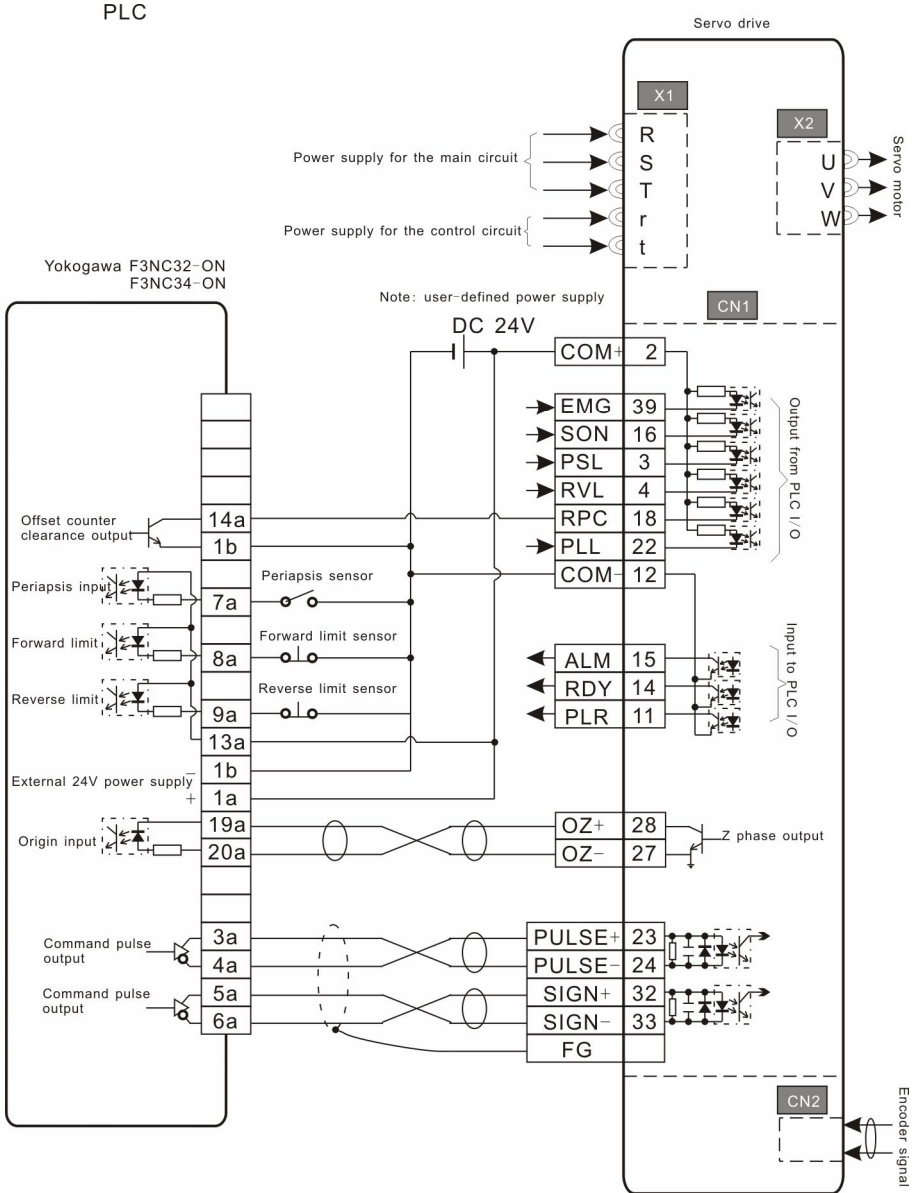

Note:  is twisted shields.

D.5 Connection with Yokogawa PLC F3NC32-ON/F3NC34-ON

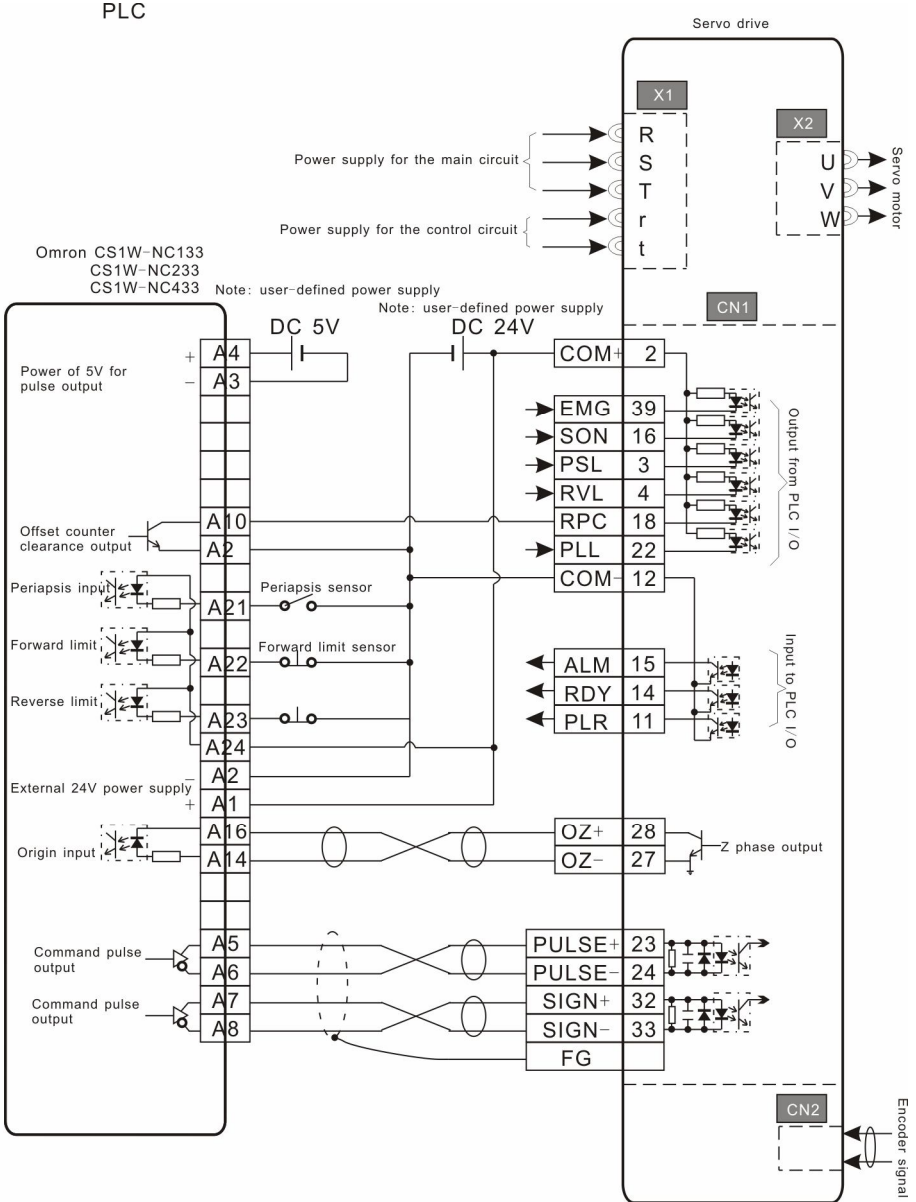

D.6 Connection with Omron CS1W-NC133/233/433



Note:  Is twisted shields.

D.7 Connection with Omron CJ1W-NC133/233/433

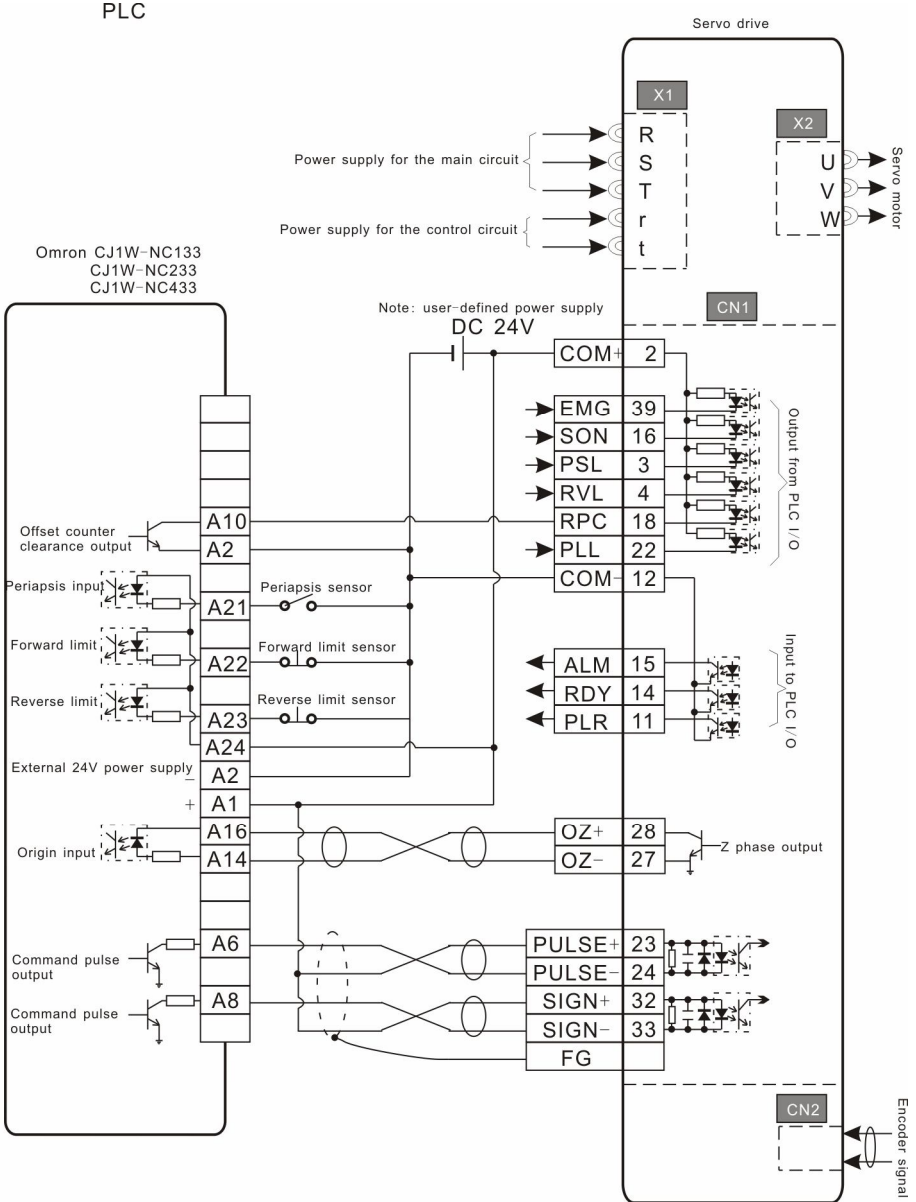

Note:  Is twisted shields.

D.8 Connection with Mitsubishi QD75D1

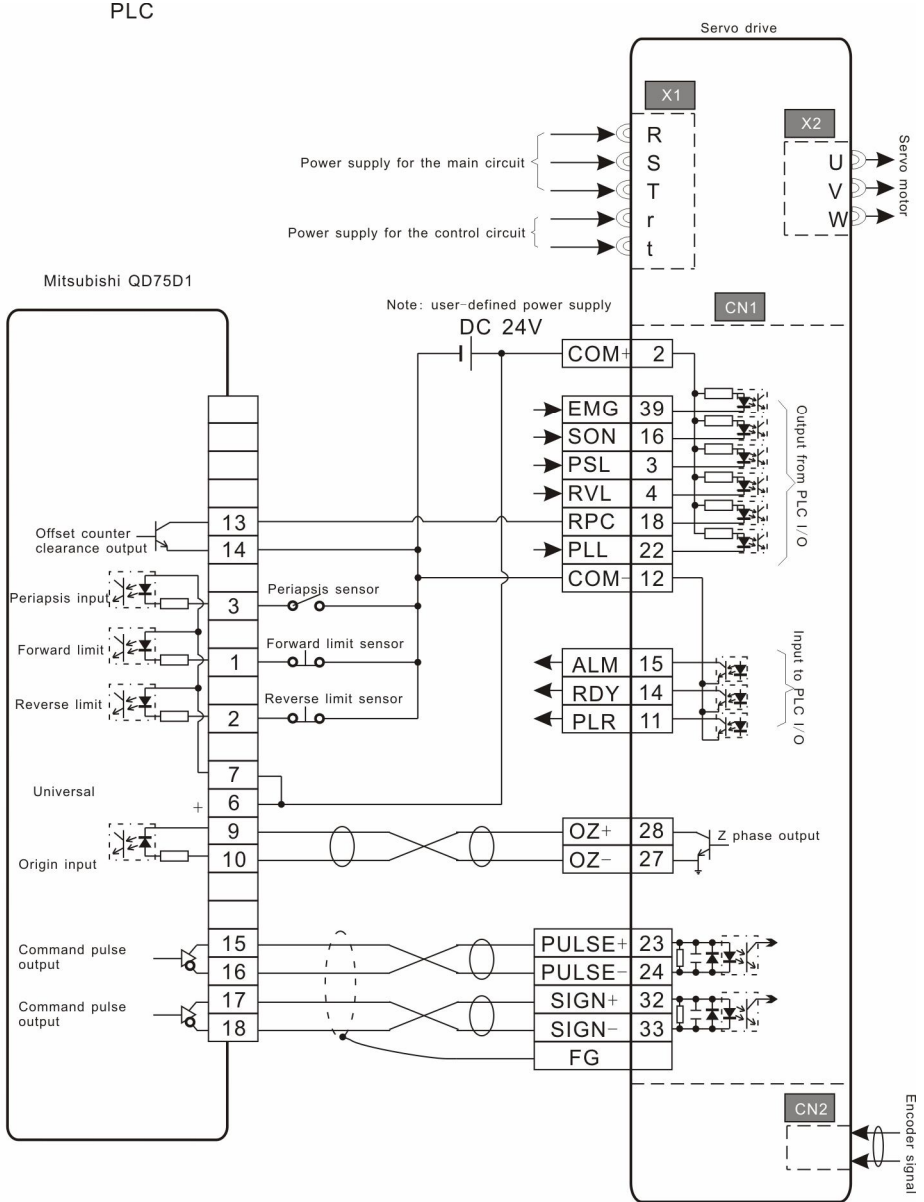

D.9 Connection with Mitsubishi FX-1PG

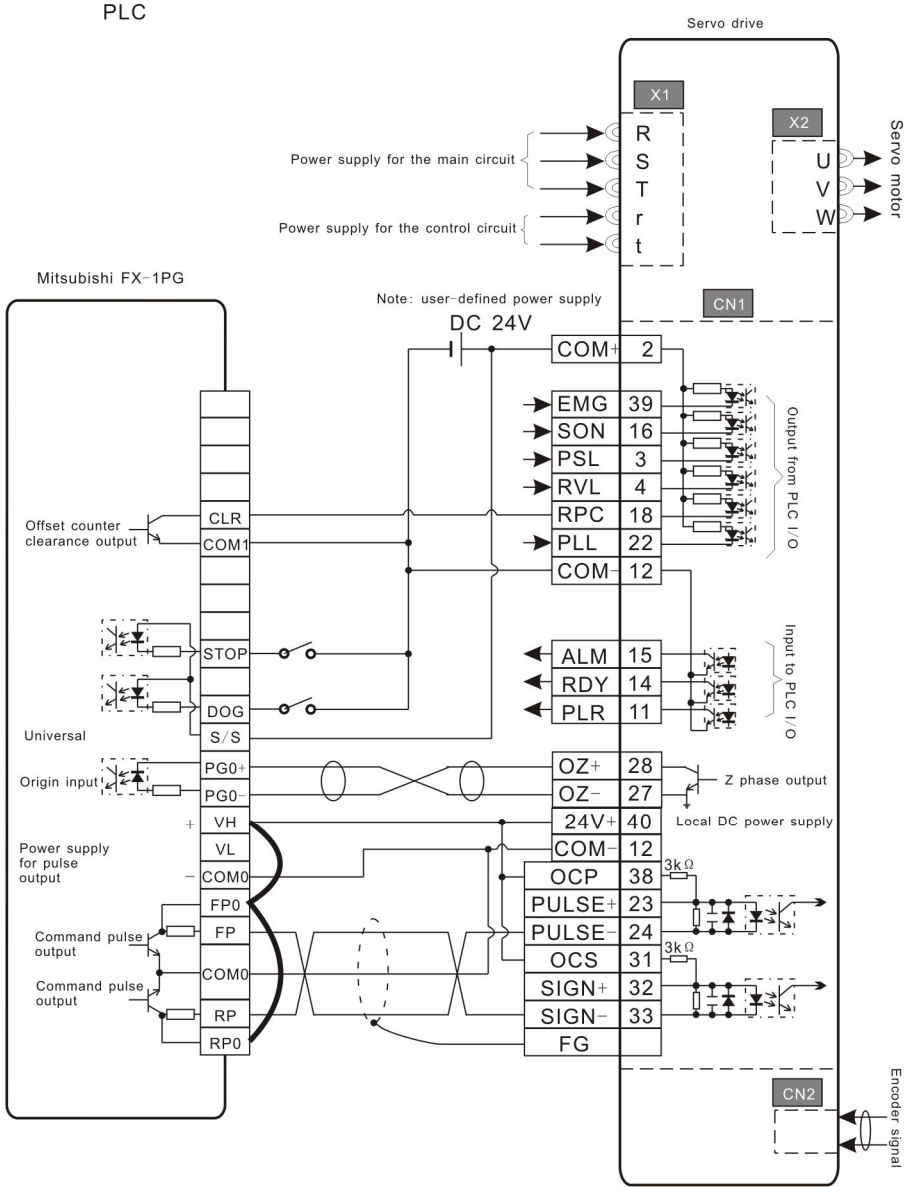

D.10 Connection with Mitsubishi FX2N-1PG

PLC

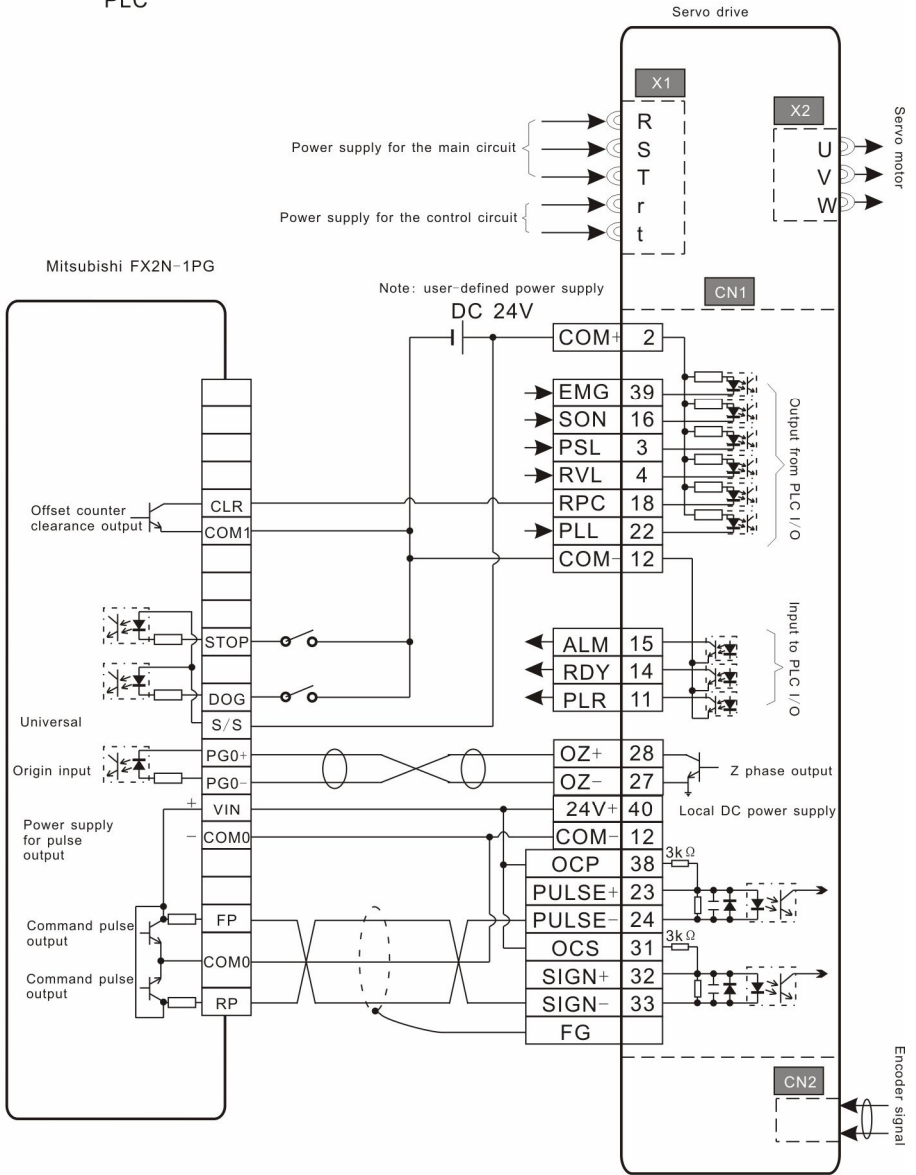

Note:  Is twisted shields.

 **SHENZHEN INVT ELECTRIC CO., LTD.**
Add: No. 4 Building , Gaofa Scientific Industrial Park, Longjing, Nanshan
District, Shenzhen, China, 518055
Tel: 86-755-86312804 Fax: 86-755-86312884
E-mail: overseas@invt.com.cn www.invt.com