

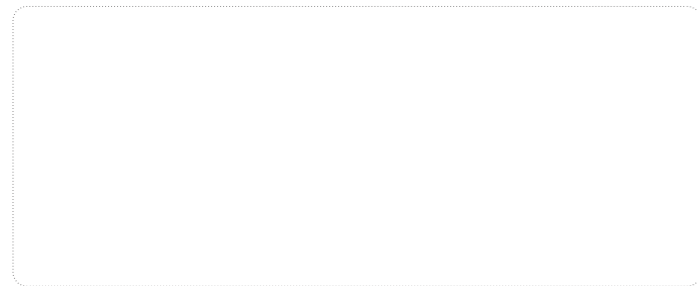

AC Servo System Catalog

Committed to Premium Quality



Service line : +86-21-34637660 Web : www.invt-tech.com

INVT INDUSTRIAL TECHNOLOGY (SHANGHAI) CO., LTD.

Building 1, No.188 Xinjun Ring Rd., Pujiang Hi-Tech Park., Shanghai, 201114, China

- Industrial Automation :** ■ Frequency Inverter ■ Servo & Motion Control ■ Motor & Electric Spindle ■ PLC
 ■ HMI ■ Intelligent Elevator Control System ■ Traction Drive
Electric Power : ■ SVG ■ Solar Inverter ■ UPS ■ Online Energy Management System

INVT Copyright.
Information may be subject to change without notice during product improving.

201312(V1.0)



Company Profile



Founded in 2005, INVT INDUSTRIAL TECHNOLOGY (SHANGHAI)CO.,LTD. (formerly Shanghai KINWAY Technologies Inc.), is a Sino-foreign joint venture controlled by INVT (Stock Code: 002334). Incorporated by several PhDs of outstanding achievements in automatic control returning from the United States, the Company has successfully introduced the ten-plus years' experience of renowned overseas large enterprises in technological development and management to China, and developed into an enterprise with scientific and technological innovation integrating research, development, production, sales and services; it has established two subsidiaries, i.e. SUZHOU KINWAY and NINGBO JUNWEI. Since its foundation, the Company has been honored as a Technology Pionerring Enterprise in Zhangjiang Hi-tech Park, Shanghai Hi-tech Enterprise, Shanghai Innovative Enterprise and a Corporate Research and Development Institute in Pudong New Area.

Relying on its internationally advanced core technologies for permanent magnet simultaneous motor, power electronics, digital control, sensor, network, field bus, ect., INVT has developed a series of high-end servo systems and computer-controlled systems specially for equipment, with INVT and KINWAY (two brands of the Company) products applied widely to plastic machinery, textile machines, oil fields, machine tools, industrial robots, packing machines, electronic manufacturing and photovoltaic field.

The Company has been dedicated to using its leading servo drivers and automation technology to promote the equipment manufacturing level and creating more value for the customers; it aspires to be a world-leading industrial automation product and service provider that is respected by the people and trusted by the customers.



CONTENTS

DB100 Series AC Servo System	03
Application fields	04
Servo Driver Product Description	05
Servo Motor Product Description	07
Servo Motor Product Description	08
Servo driver & External device cable	11
Standard Wiring Diagram	12
Servo driver plug signal arrangement diagram	15
DA100 Series AC Servo System	16
System Composition	17
Servo Driver's Interface Drawing	18
Product Advantages	18
Servo Driver Type Description	19
Technical Parameters of Servo Driver	20
Mechanical Dimensions of Servo Driver	22
Standard Wiring Diagram	23
Servo Motor Type Description	25
60/80-Flange Servo Motor	26
130-Flange Servo Motor	27
180-Flange Servo Motor	28
Cable Type Description	29
Servo System Order Guide	30
MH500 Servo-Hydraulic System For Injection Molding Machines	31
Servo-Hydraulic System	32
Servo-Hydraulic System for injection molding machine	33
Selection	34
System Specification	35
MH500 Series Servo Driver Specifications	36
MH500 Series Servo Driver Dimension	37
Mm Series Servo Motor Specifications	38
Mm Series Servo Motor Dimension	39
System interconnect diagram	40
Successful Cases	41
Sales & Service Network	42



DB100 Series AC Servo System

Characteristics

voltage grade	driver power	servo driver	servo motor	rated torque/ rated speed
220V	200W	SV-DB100-0R2-2-1R	SV-ML06-0R2G-2-1A0	0.64Nm/3000rpm
	400W	SV-DB100-0R4-2-1R	SV-ML06-0R4G-2-1A0	1.27Nm/3000rpm
	750W	SV-DB100-0R7-2-1R	SV-ML08-0R7G-2-1A0	2.4Nm/3000rpm
	1.0kW		SV-ML08-1R0F-2-1A0	4Nm/2500rpm
	1.0kW	SV-DB100-1R0-2-1R	SV-MM13-1R0F-2-1A0	5Nm/2500rpm
	1.5kW	SV-DB100-1R5-2-1R	SV-MM13-1R5F-2-1A0	7.7Nm/2500rpm
	2.0kW	SV-DB100-2R0-2-1R	SV-MM13-2R0F-2-1A0	10Nm/2500rpm
	2.3kW		SV-MM13-2R3B-2-1A0	15Nm/1500rpm
380V	1.0kW	SV-DB100-1R0-4-1R	SV-MM13-1R0F-4-1A0	5Nm/2500rpm
	1.5kW	SV-DB100-2R0-4-1R	SV-MM13-1R5F-4-1A0	7.7Nm/2500rpm
	2.0kW		SV-MM13-2R0E-4-1A0	10Nm/2000rpm
	3.0kW	SV-DB100-3R0-4-1R	SV-MM18-3R0B-4-1A0	19Nm/1500rpm
	4.4kW	SV-DB100-4R4-4-1R	SV-MM18-4R4B-4-1A0	27Nm/1500rpm
	5.5kW	SV-DB100-5R5-4-1R	SV-MM18-5R5B-4-1A0	35Nm/1500rpm

Application fields

- ◆ Electronic Production Machinery: Winding machine, wire-stripping machine, Lithium battery manufacturing equipment, LED manufacturing equipment, dispenser, component inserter, etc.
- ◆ CNC Equipment: electro machining, wire-electrode cutting, NC lathe, carves-milling machine, deep hole drilling, pipe bender, coiling machine, etc.
- ◆ Packaging machinery: bag machine, sealing and cutting machine, blister packaging machine, horizontal packaging machine, labeller, ect.
- ◆ Printing machinery: screen printer, sticker trademark printing press, paper cutter, die-cutting machine, gilding press, folder, etc.
- ◆ Textile machinery: computerized flat knitting machine, embroidery machine, air-jet loom, water-jet loom, warp knitting machine, etc.
- ◆ Plastic machinery: Loading manipulator, automatic bottle blowing machine
- ◆ Others: glass equipment, TJK, test equipment, etc.

Servo Driver Product Description

Model Description

SV-DB100-0R4-2-1 R

① ② ③ ④ ⑤ ⑥

①

Identification	Product category
SV	Servo system

②

Identification	Product series
DB100	DB100 Series

③

Identification	Rated power
0R2	200W
0R4	400W
0R7	750W
1R0	1.0kW
1R5	1.5kW
2R0	2.0kW
3R0	3.0kW
4R4	4.4kW
5R5	5.5kW

④

Identification	Voltage class
2	AC230V
4	AC400V

⑤

Identification	Encoder type
1	2500-wire standard incremental
2	2500-wire wire-saving incremental

⑥

Identification	Communication mode
R	RS485

Special functions

- ◆ High overload capacity: Instantaneous torque can reach 3 times overload, which effectively overcomes the inertia moment of inertia load at starting.
- ◆ Built-in mechanical resonance suppression function, which can effectively inhibit the resonance phenomenon of mechanical structure.
- ◆ Excellent high-speed reflection performance: Speed response bandwidth is up to 650Hz or more, and speed ranges from -3000r/min to 3000r/min with an acceleration time of only 6ms.
- ◆ Full ranges of models have built-in braking unit and braking resistor.
- ◆ Above 1KW servo drivers can be directly powered by 380v, which saves incoming transformer and effectively reduces plan costs.
- ◆ Automatic gain adjustment function, which allows for identification of load inertia and more convenient debugging.

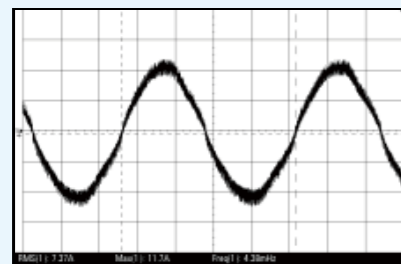

0.1r/min current waveformR

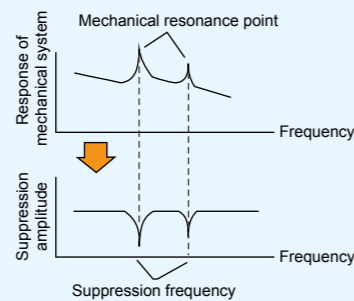

esonance Suppression Figure

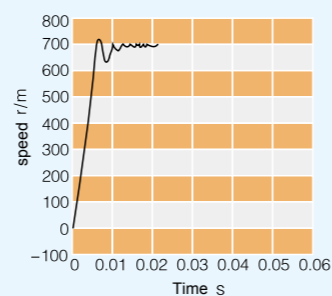

Speed response waveform of 5 times inertia ratio

Servo Driver Performance Specifications

model	SV-DB100-0R2-2-1R	SV-DB100-0R4-2-1R	SV-DB100-0R7-2-1R	SV-DB100-1R0-2-1R	SV-DB100-1R5-2-1R	SV-DB100-2R0-2-1R	SV-DB100-3R0-4-1R	SV-DB100-4R4-4-1R	SV-DB100-5R5-4-1R
Power	200W	400W	750W	1.0kW	1.5kW	2.0kW	3.0kW	4.4kW	5.5kW
Rated current	1.8A	2.8A	4.5A	5.7A	8A	10A	8A	11A	14A
main circuit power supply	single phase or 3 phase AC 230V ± 15%/50Hz				3 phase AC 230V ±15%/50Hz		3 phase AC 400V ± 15%/50Hz		
Control circuit power supply	Single phase 230v ± 15%/50Hz						Single phase 400v ± 15%/50Hz		
interface power supply	DC 12V~24V, ± 10%, greater than 500mA								
control mode	Vector control. SVPWM								
Basic control mode	positon control mode. Speed control mode, torque control mode								
dynamic breaking function	YES								
regeneration breaking unit	built-in breaking resistor, and it also can connect an external one								
digital input and output	13 optical isolation inputs, 7 open collector output								
analog input and output	2 inputs : -10V~+10V; 2 outputs : 0V~+10V								
pulsed quantity input and output	2 difference signal inputs or open collector signal inputs, 3 encoder difference signal outputs								
protect function	over current, over voltage, over load, over heat, encoder fault over speed, under voltage etc.								
maximum pulse frequency	500kHz (differential input) : 200kHz (open collector input)								
feedback pulse for positioning	A/B orthogonal pulse, resolution ratio: 10000 pulse/revolution								
magnify range of pulse	electronic gear A/B: A=1~65535, B=1~65535, 1/50 < A/B < 500								
positioning precision	±1 pulse								
speed stabilizing precision	± 0.03%								
torque control range	controlled via parameters setting or external analog input setting DC 0~±10V, maximum torque: 300% rated torque								
speed frequency response	500Hz								
speed control range	the lowest speed is 0.1RPM, and the highest speed is 5000RPM								
analog input for speed	DC 0~±10V/maximum speed								
analog input for torque	DC 0~±10V/maximum torque								
linearity of torque	less than ± 10%								
recommended inertia ratio	less than 15 times								
communication	CAN, Modbus (RS232 and RS485)								
protection grade	IP20, natural cooling				IP20, forced air cooling				
ambient	working temperature:0~45°C, store temperature:-20~80°C (no freeze),humidity:≤90RH (no condensation)								

Servo Driver Product Description

Mounting dimensions of servo driver

SV-DB100-0R2/0R4 (unit: mm)

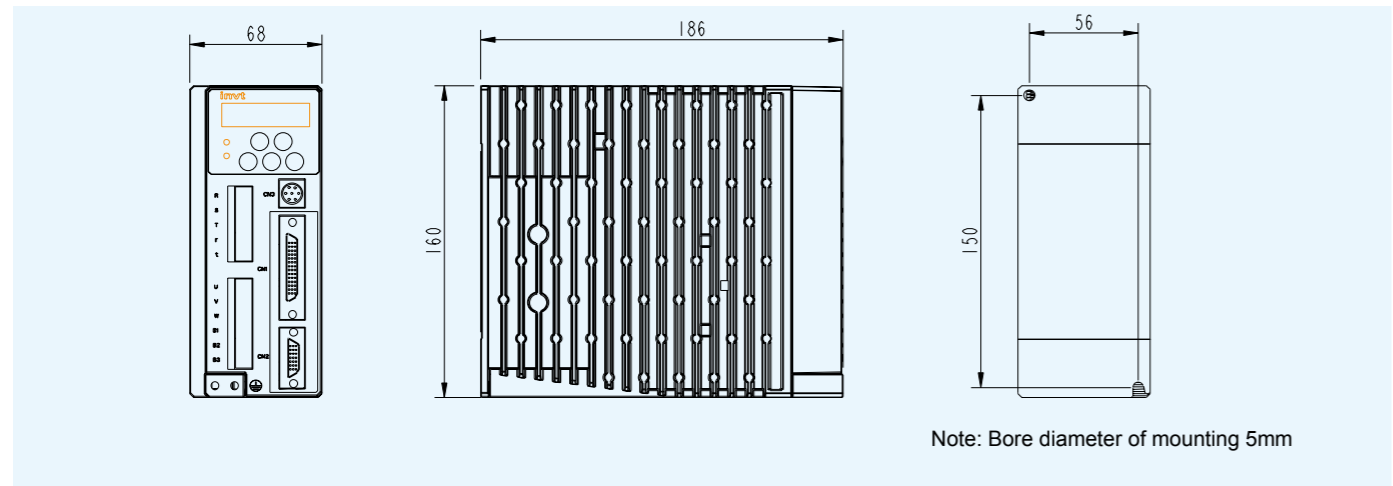

SV-DB100-0R7/1R0/1R5/2R0 (unit: mm)

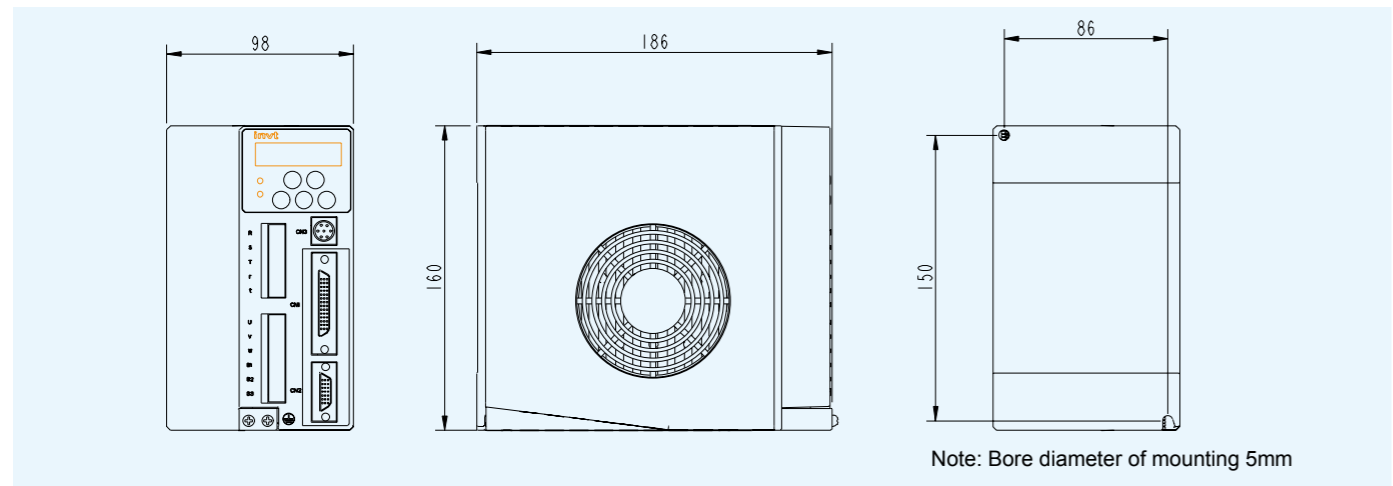

SV-DB100-3R0/4R4/5R5 (unit: mm)

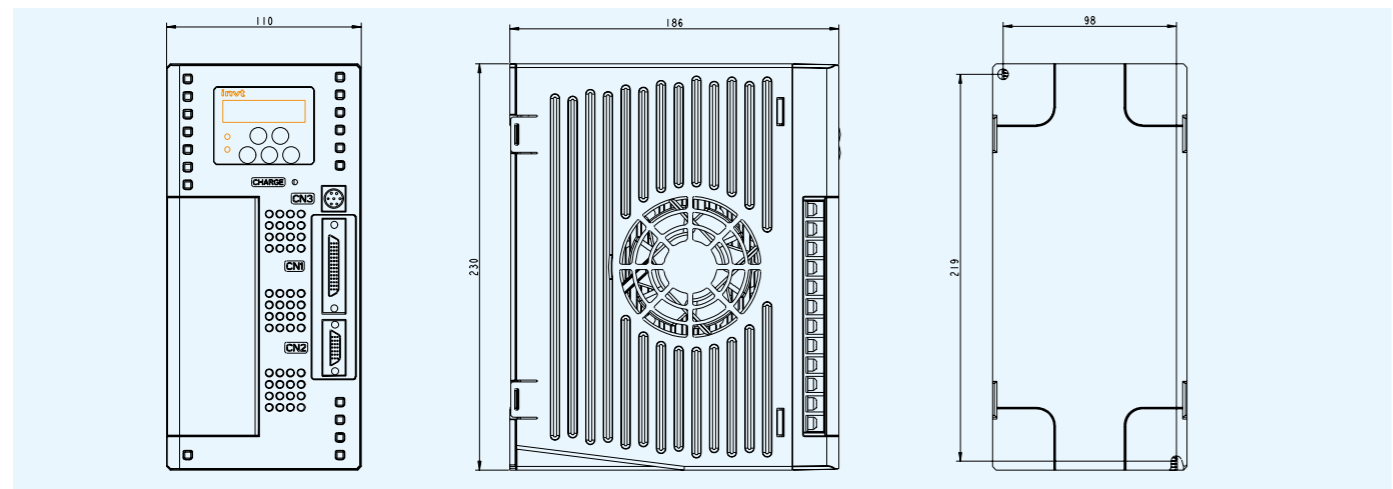

Servo Motor Product Description

Product Description

SV-ML06-0R4G-2-1 A0

① ② ③ ④ ⑤ ⑥ ⑦ ⑧ ⑨

①

Identification	Product category
SV	Servo system

⑤

Identification	Rated speed
A	1000rpm
B	1500rpm
E	2000rpm
F	2500rpm
G	3000rpm

⑧

Identification	Shaft terminal connection
A	Solid with key (standard configuration)
B	Optical axis

②

Identification	Inertia level
ML	General-purpose small inertia servo motor
MM	General-purpose medium inertia servo motor

⑥

Identification	Voltage class
2	AC230V
4	AC400V

⑨

Identification	Optional accessories
0	With oil seal
1	No optional accessories
2	With oil seal & band-type brake
3	With band-type brake

③

Identification	Machine base #
06	60mm
08	80mm
11	110mm
13	130mm
18	180mm

⑦

Identification	Encoder type
1	2500-wire standard incremental
2	2500-wire wire-saving incremental
3	17-bit single ring absolute
4	17-bit multi-ring absolute

④

Identification	Rated power
0R2	200W
0R4	400W
0R7	750W
1R0	1.0kW
1R5	1.5kW
2R0	2.0kW
2R3	2.3kW
3R0	3.0kW
4R4	4.4kW
5R5	5.5kW



Table of Motor Electrical Parameters

60/80 Series

Motor type	SV-ML06-0R2G-2-1A0	SV-ML06-0R4G-2-1A0	SV-ML08-0R7G-2-1A0	SV-ML08-1R0F-2-1A0
Rated power	200W	400W	750W	1.0kW
Rated current (A)	1.4	2.4	3	4.4
Rated torque (Nm)	0.64	1.27	2.4	4
Peak torque (Nm)	1.91	3.8	7.1	12
Rated speed (rpm)	3000	3000	3000	2500
Rotor inertia (Kg.cm ²)	0.17	0.3	1.82	2.97
Counter potential (V/Krpm)	32	31	48	56
Torque coefficient (Nm/A)	0.45	0.5	0.8	0.9
Motor insulation class	Class B(130°C)			
Protection level	IP65			
Operating environment	Temperature: -20°C~50°C (Unfrozen); Humidity: Below 90% RH (No condensation)			

130 Series

Motor type	SV-MM13-1R0F-2-1A0	SV-MM13-1R5F-2-1A0	SV-MM13-2R0F-2-1A0	SV-MM13-2R3B-2-1A0
Rated power	1.0kW	1.5kW	2.0kW	2.3kW
Rated current (A)	5	7.5	10	9.5
Rated torque (Nm)	5	7.7	10	15
Peak torque (Nm)	15	22	25	30
Rated speed (rpm)	2500	2500	2500	1500
Rotor inertia (Kg.cm ²)	10.6	15.3	19.4	27.7
Counter potential (V/Krpm)	68	68	70	114
Torque coefficient (Nm/A)	1	1.03	1	1.58
Motor insulation class	Class B(130°C)			
Protection level	IP65			
Operating environment	Temperature: -20°C~50°C (Unfrozen); Humidity: Below 90% RH (No condensation)			

180 Series

Motor type	SV-MM18-3R0B-4-1A0	SV-MM18-4R4B-4-1A0	SV-MM18-5R5B-4-1A0
Rated power	3.0kW	4.4kW	5.5kW
Rated current (A)	7.5	10	12
Rated torque (Nm)	19	27	35
Peak torque (Nm)	47	67	70
Rated speed (rpm)	1500	1500	1500
Rotor inertia (Kg.cm ²)	38	61	86
Counter potential (V/Krpm)	158	172	181
Torque coefficient (Nm/A)	2.5	2.7	2.9
Motor insulation class	Class B(130°C)		
Protection level	IP65		
Operating environment	Temperature: -20°C~50°C (Unfrozen); Humidity: Below 90% RH (No condensation)		

Table of Motor Mechanical Dimensions

Motor type	LA	LB	LC	LD	LE	Flange face dimension			Shaft end dimension				Weight kg
						LF	LZ	LG	S	Q	H	W	
SV-ML06-0R2G-2-1A0	111(159)	30	3	7	50	60	5.5	70	14	20	16	5	1.11(1.8)
SV-ML06-0R4G-2-1A0	136(184)	30	3	7	50	60	5.5	70	14	20	16	5	1.33(2.1)
SV-ML08-0R7G-2-1A0	151(206)	35	3	8	70	80	6	90	19	25	21.5	6	2.86(3.6)
SV-ML08-1R0F-2-1A0	190(245)	35	3	8	70	80	6	90	19	25	21.5	6	3.8(4.8)
SV-MM13-1R0F-2-1A0	171(243)	57	5	14	110	130	9	145	22	40	24.5	6	8.2(10.2)
SV-MM13-1R5F-2-1A0	192(249)	57	5	14	110	130	9	145	22	40	24.5	6	10(10.8)
SV-MM13-2R0F-2-1A0	209(266)	57	5	14	110	130	9	145	22	40	24.5	6	11.5(12.3)
SV-MM13-2R3B-2-1A0	241(298)	57	5	14	110	130	9	145	22	40	24.5	6	14.4(15.2)
SV-MM18-3R0B-4-1A0	232(289)	65	3.2	18	114.3	180	13.5	200	35	51	38	10	20.5(22.5)
SV-MM18-4R4B-4-1A0	262(319)	65	3.2	18	114.3	180	13.5	200	35	51	38	10	25.5(27.5)
SV-MM18-5R5B-4-1A0	292(349)	65	3.2	18	114.3	180	13.5	200	35	51	38	10	30.5(32.5)

(Note) 1. Figures in brackets refer to the value of the motor with brake.

2. Same power; Size of 380V rating motor is identical to that of 220V rating motor.

Figure of Motor Mounting Dimensions

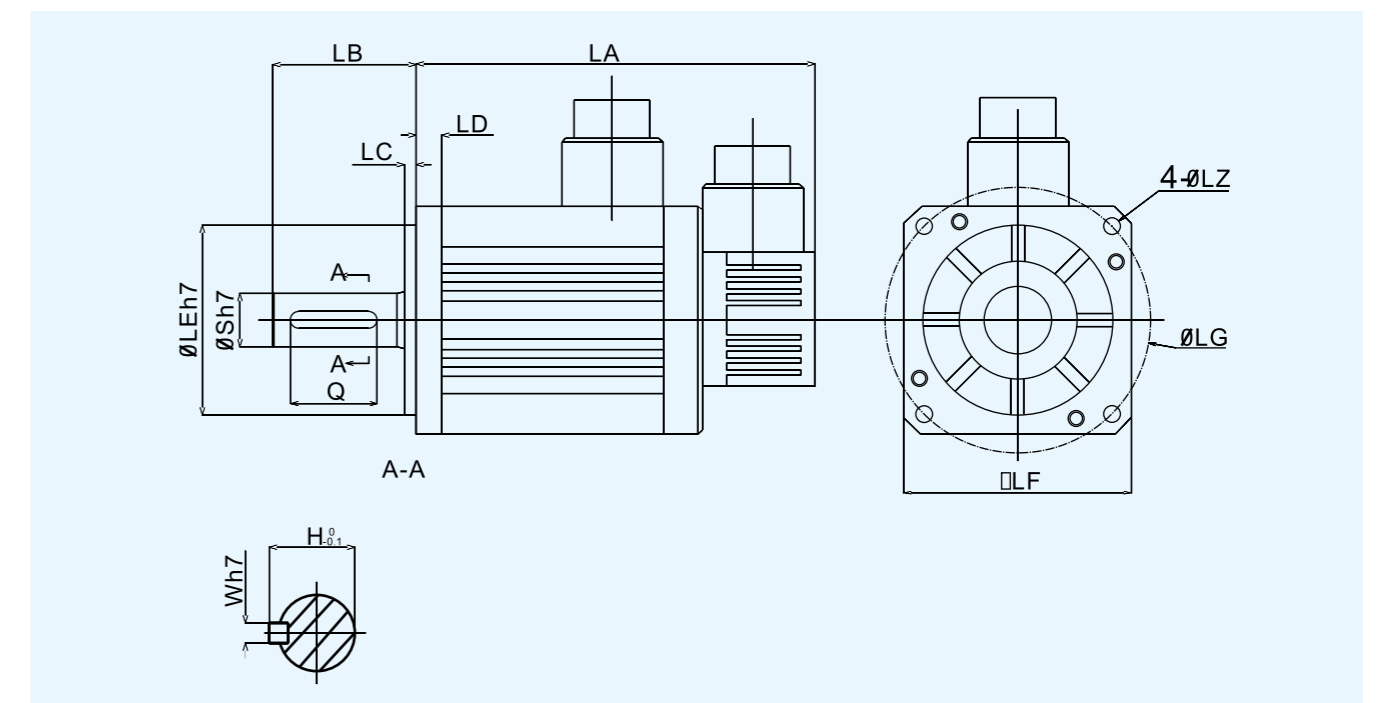

Servo driver & External device cable

External device & specification

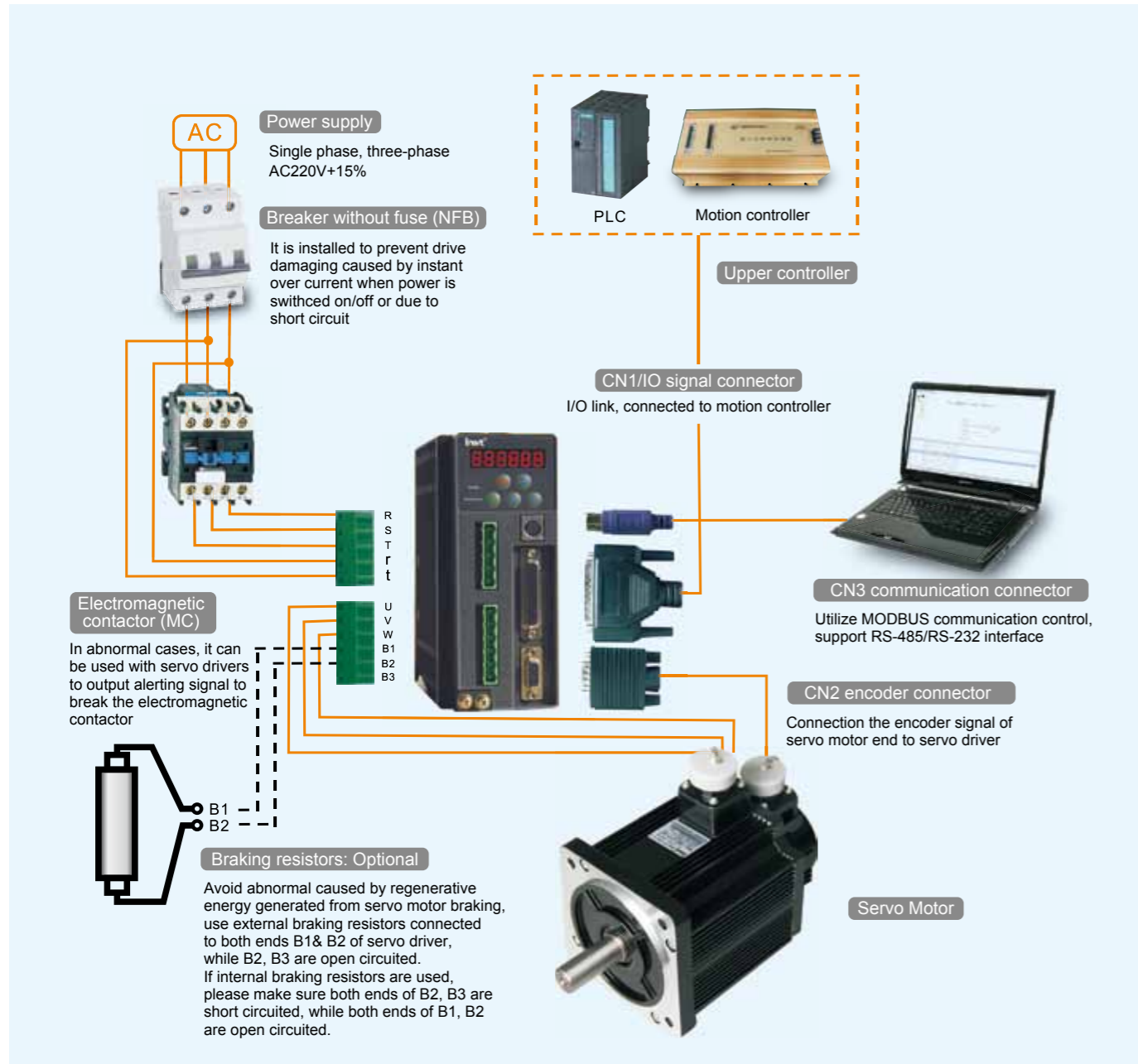

Installation Precautions

1. Check if power supply and wiring of R, S, T and r, t are correct
2. Confirm if the output U, V, W terminals wiring phase sequence of servo motor are correct
3. Use external braking resistors connected to both ends B1 & B2 of servo driver, while B1, B2 are open circuited. If internal braking resistors are used, please make sure both ends of B2, B3 are short circuited, while both ends of B1, B2 are open circuited.

Standard Wiring Diagram

Position mode standard wiring diagram

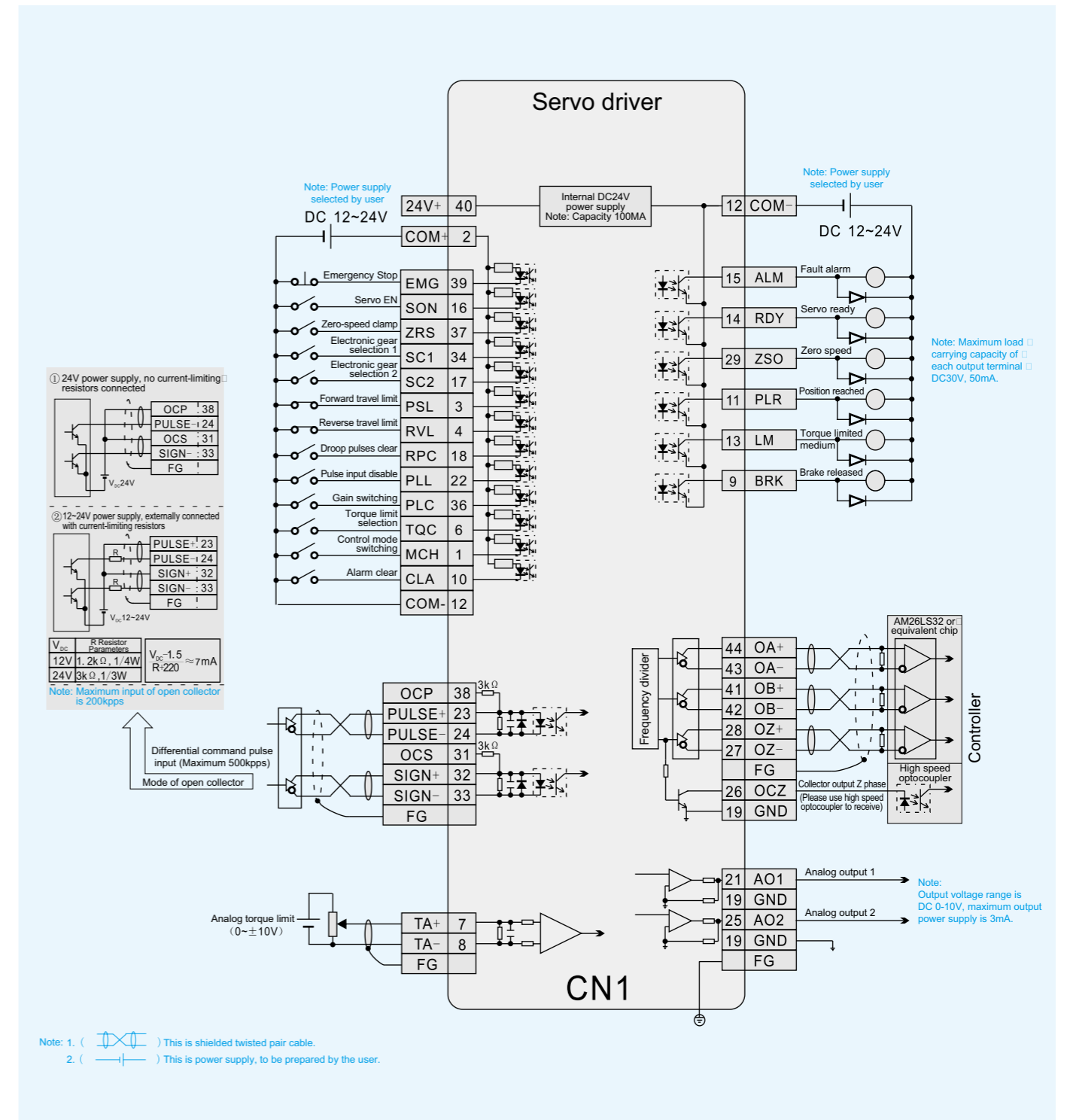

Speed mode standard wiring diagram

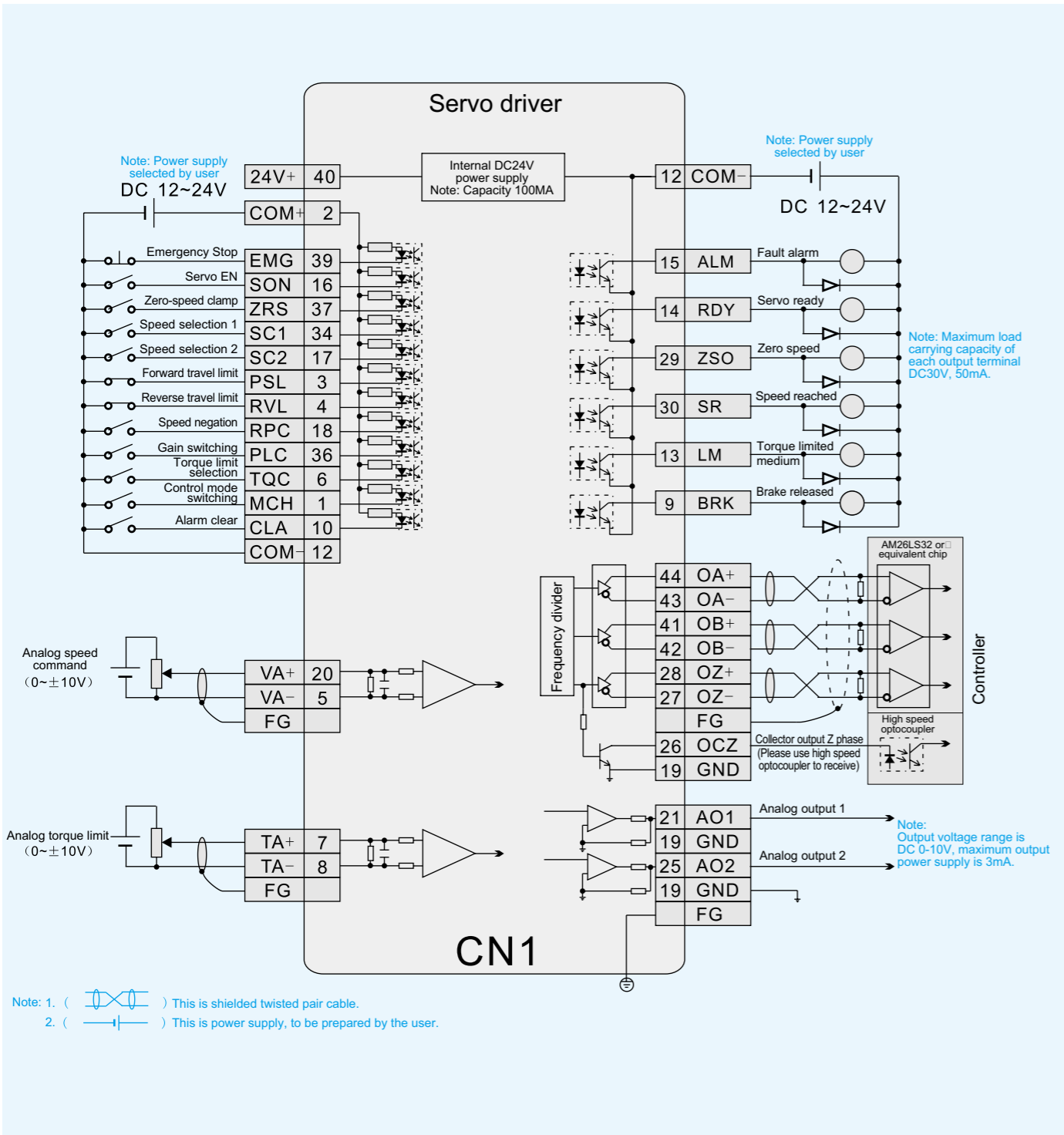

Torque mode standard wiring diagram

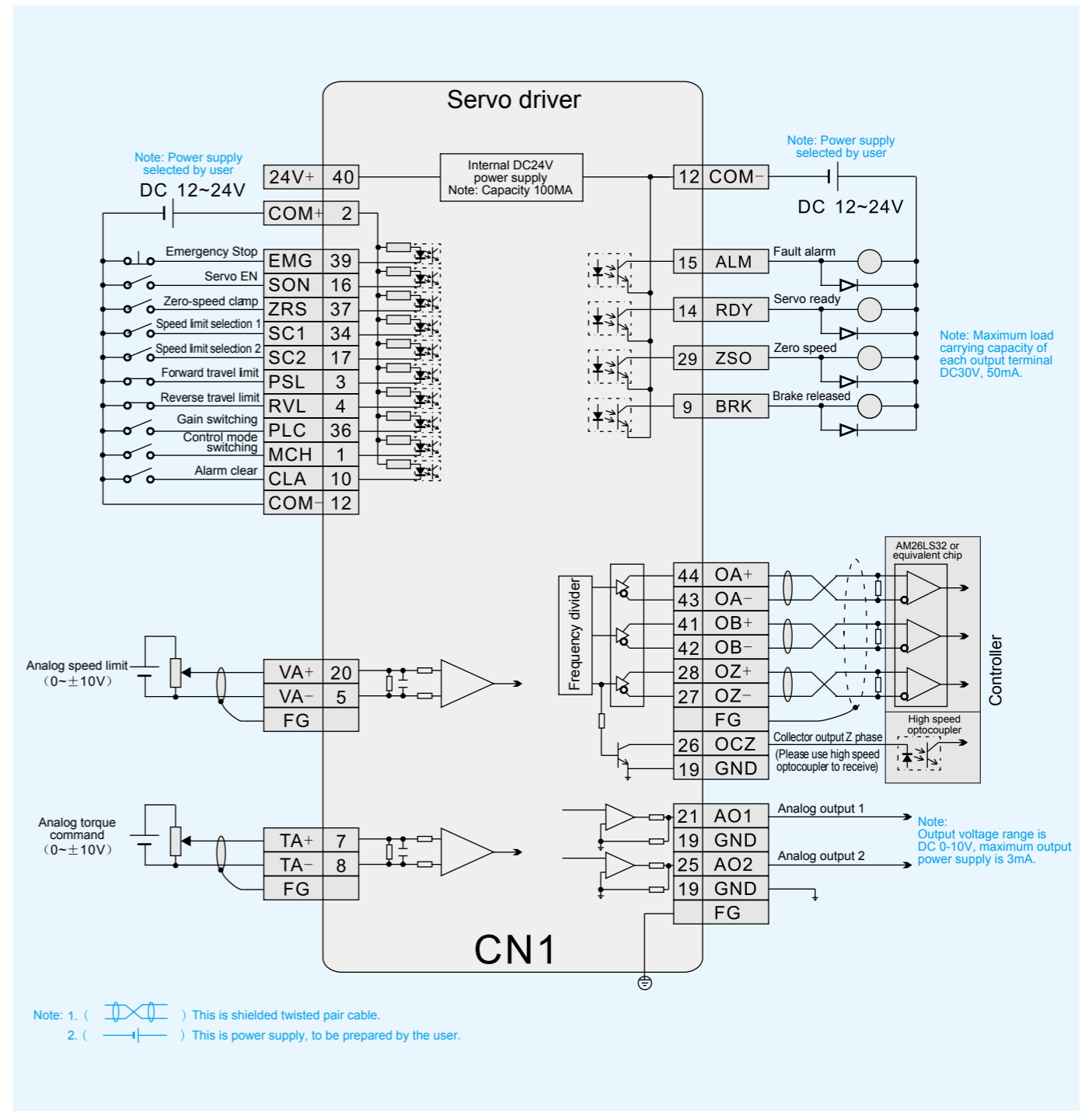

Servo driver plug signal arrangement diagram

CN1 Pin signal arrangement

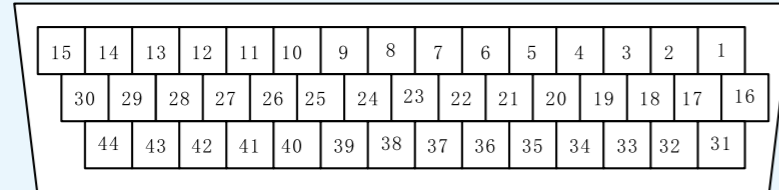

CN1 Plug pin arrangement

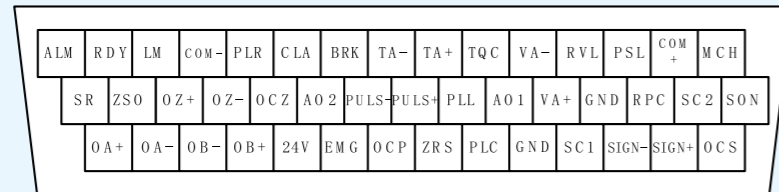

CN1 Plug signal arrangement

CN2 Pin signal arrangement

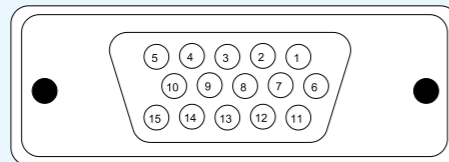

CN2 Pin #	1	2	3	4	5	6	7	8	9	10	11	12	13	14	15
Definition	V+	W+	A+	A-	5V	U+	V-	W-	B-	B+	U-	GND	Z-	Z+	/
Cable color	black	brown	red	red and white	purple	orange	black and white	brown and white	blue	blue and white	orange and white	purple and white	green	green and white	/

CN3 Pin signal arrangement

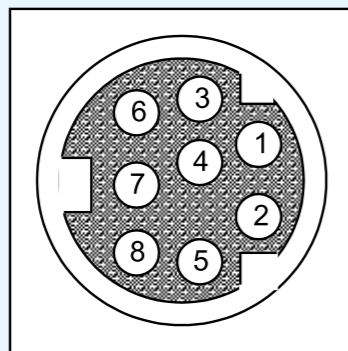

CN3 Pin #	1	2	3	4	5	6	7	8
Definition	RXD	GND	TXD	CANL	/	CANH	RS485-	RS485+



DA100 Series AC Servo System

System Composition

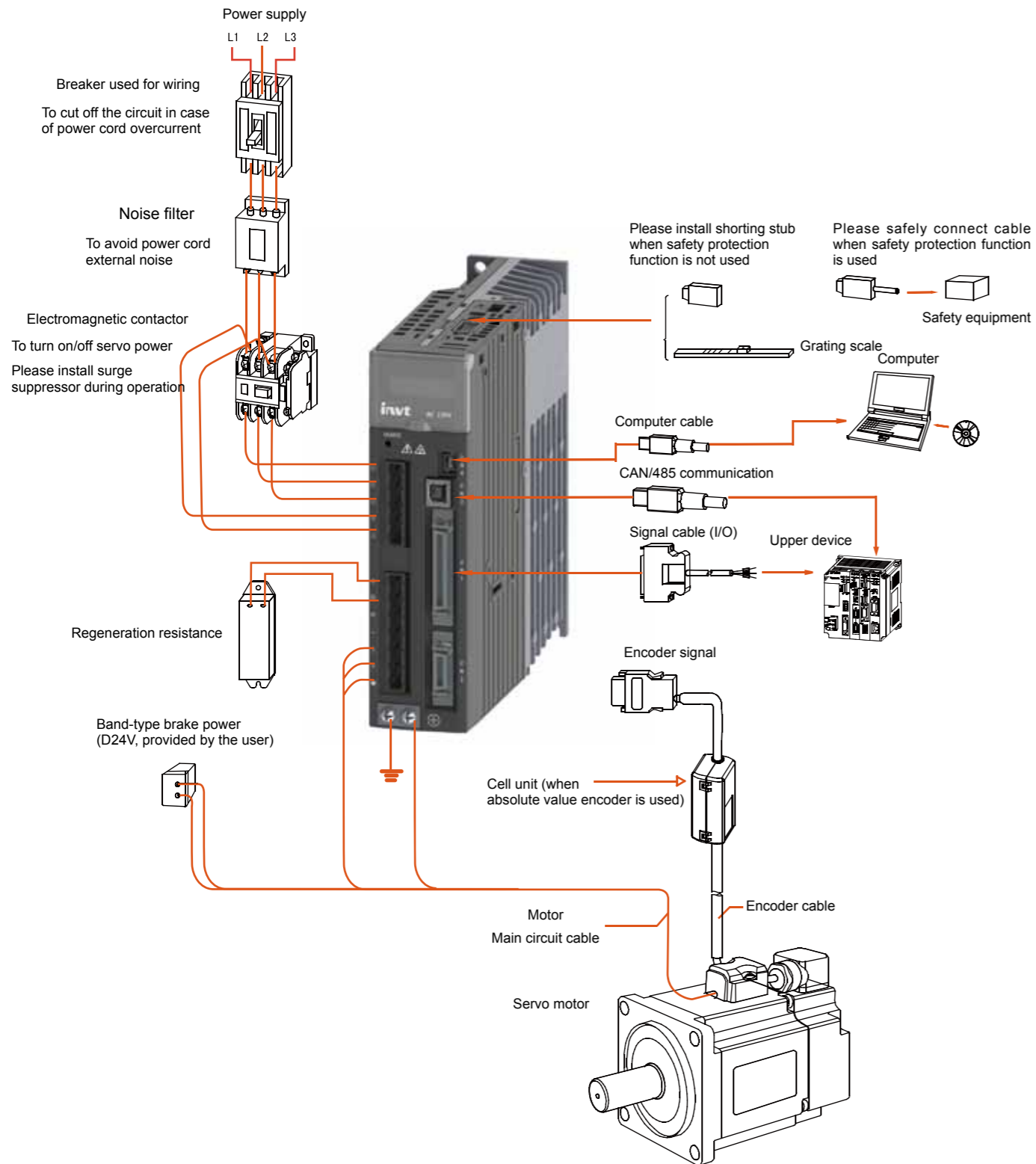

Servo Driver's Interface Drawing

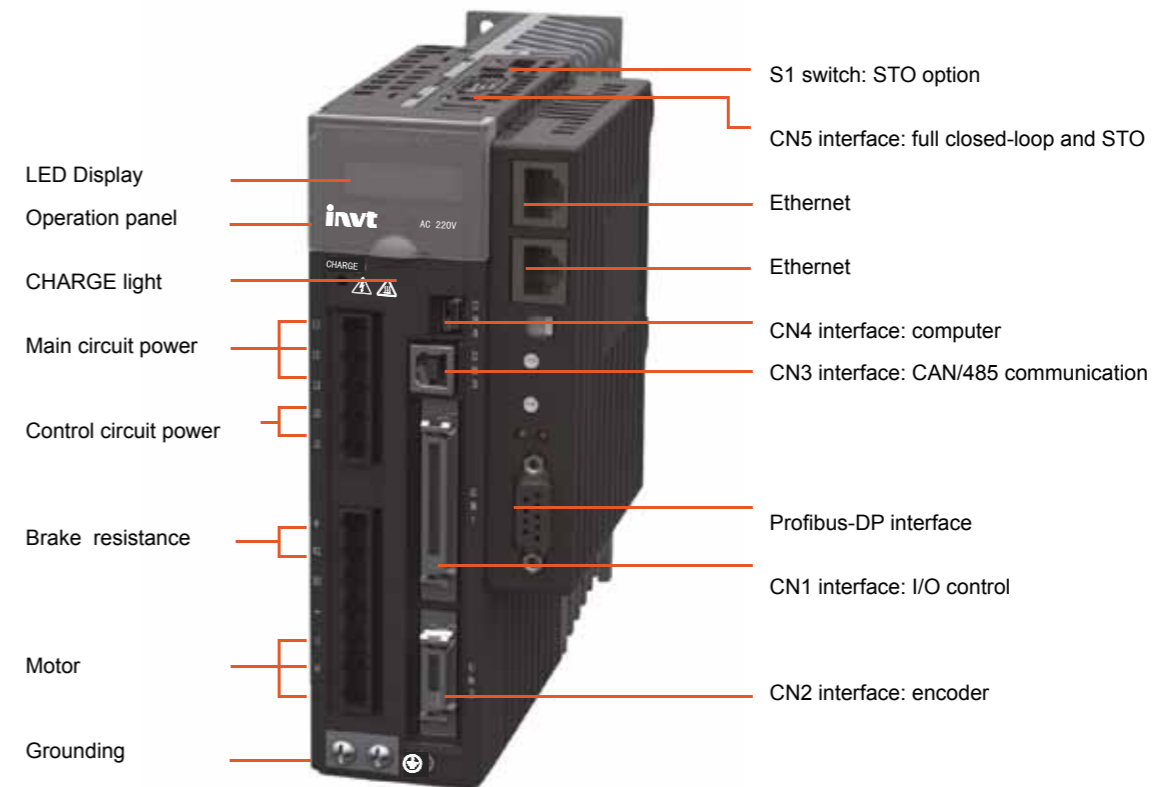

Product Advantages

■ Super speed response capability

The speed response frequency is $\geq 1.8\text{kHz}$, significantly shortening the setting time, leading the industry standard.

■ Excellent positioning accuracy

Standard configuration of 17-bit absolute value encoder, significantly improving positioning accuracy and enhancing low-speed stability.

■ Full closed-loop control

Support the encoder or grating scale mounted at external load ends, achieve full closed-loop control, reduce the impact of mechanical drive back lash, and further ensure the positioning accuracy of machine terminal.

■ Internal position control

Through input terminal packing of orders (external I/O control), it can realize multistage position control or speed control. For simple motion control, the middle PLC control unit can be saved to significantly reduce control costs.

Rich communication interface

Support Canopen, Profibus-dp bus, Ethercat high-speed Ethernet communication protocols, can realize long-distance and multi-axis high-speed synchronous control through networking.

Smarter and Easier Application

Have online/offline inertia identification, automatic gain adjustment, automatic/manual notch filter, automatic/manual damping filter functions, etc., can achieve “simplified” parameter setting, effectively overcome mechanical resonance and suppress the shimmy phenomenon at the end of long-arm mechanism.

Servo Driver Model Description

SV-DA100-0R4-2-E

① ② ③ ④ ⑤

①

Symbol	Product Category
SV	Servo system

②

Symbol	Product Line
DA100	Servo driver

③

Symbol	Rated Power
0R2	200W
0R4	400W
0R7	750W
1R0	1.0kW
1R5	1.5kW
2R0	2.0kW
3R0	3.0kW
4R4	4.4kW
5R5	5.5kW

④

Symbol	Voltage Class
2	220VAC
4	380VAC

⑤

Model Code

Model Code

Code	Model	pulse input	16-bit analog import	Full closed-loop	STO	RS485	Canopen	Profibus-dp	Ethercat
E	pulse type	√	x	x	x	√	x	x	x
S	Standard type	√	√	√	√	√	x	x	x
C	Canopen bus type	x	x	x	x	x	√	x	x
P	Profibus bus type	x	x	x	x	x	x	√	x
N	High-speed Ethernet type	x	x	x	x	x	x	x	√

Technical Parameters of Servo Driver

Model SV-DA100-□□□-□	0R2-2	0R4-2	0R7-2	1R0-2	1R5-2	2R0-2	3R0-2	1R0-4	1R5-4	2R0-4	3R0-4	4R4-4	5R5-4
Rated power (kw)	0.2	0.4	0.75	1.0	1.5	2.0	3.0	1.0	1.5	2.0	3.0	4.4	5.5
Rated current (A)	1.8	2.8	4.5	5	7.6	10	16.5	3.5	4.5	6.5	8.5	12	16.5
Main power supply	Single-phase/three-phase AC200V-15%~10%				3 phase AC 200V - 15%~10%			Three-phase AC400V-15%~10%					
Control power supply	Single-phase AC200V-15%~10%							Single-phase AC400V-15%~10%					
Control mode	1. Position control; 2. Speed control; 3. Torque control; 4. Position/speed mode switch; 5. Speed/torque mode switch; 6. Position/torque mode switch; 7. Internal position planning mode; 8. Mixed control mode; 9. Full closed-loop control												
Encoder feedback	17-bit absolute value encoder (standard configuration), 2500ppr incremental encoder (compatible)												
Brake unit	Built-in and external												
Port	Control signal	Input	General 10 channel input (functions can be configured freely through relevant parameters)										
		Output	General 6 channel output (functions can be configured freely through relevant parameters)										
	Analog quantity	Input	3 channel input (1-way 16-bit A/D input and 2-way 12-bit A/D input)										
		Output	3-channel output (2-channel analog quantity monitor output and 1-channel number monitor output)										
	Impulse signal	Input	2-way input (1-way photocoupling input and 1-way differential input)										
		Output	6-way output (3-way differential output and 3-way open collector output)										
Communication function	Ethernet	RJ45 cable directly connected computer communication monitor (optional)											
	Profibus-DP	1: n communication (optional)											
	RS485	1: n communication (standard)											
	EtherCAT	1: n communication (optional)											
	Canopen	1: n communication (optional)											
	USB	1:1 communication upper computer software (standard)											
Safety terminal	STO	Safe torque off (in line with the latest European safety standard) (optional)											

Technical Parameters of Servo Driver

Function	Position control	Control input	1. Retention pulse zero clearing; 2. Command pulse input prohibition; 3. Command frequency multiplication switch; 4. Vibration control switch		
		Control output	Positioning finish output		
		Impulse input	Max. pulse input frequency	1. Photocoupling: differential input 500Kpps, collector open input 200Kpps; 2. Linear receiver: differential input 4Mpps	
			pulse input mode	1. Positive direction/negative direction; 2. A/B-phase; 3. Command pulse/command direction	
			Electronic gear	1/10000~1000 x	
		Filter	1. Command smooth filter; 2. FIR filter		
		Analog signal input	Torque restrain command input	Support separate clockwise/counterclockwise torque limitation	
	Vibration control	Can restrain 1~200Hz front vibration and whole-machine vibration			
	Impulse output	1. Support any fractional frequency setting under encoder resolution; 2. Provided with B-phase negation function			
	Function	Speed control	Control input	1. Internal command speed option 1; 2. Internal command speed option 2; 3. Internal command speed option 3; 4. Zero speed clamping	
Control output			Speed arrival		
Impulse input			Speed command input	Support speed command input after relevant setting according to analog quantity voltage DC±10V	
		Torque limit input	Support separate clockwise/counterclockwise torque limitation		
Internal speed command		Can switch internal 8-stage speed according to external control input			
Speed command +/- speed adjustment		Support separate setting of acceleration/deceleration time, and also S-curve acceleration/deceleration (+/-) setting			
Zero speed clamping		Zero speed clamping function in speed mode can set working in speed/position mode			
Speed command filter		Disposable delay filter of analog quantity input speed command			
Speed command null drift restrain		Support null drift restrain on external interference, with accuracy of 0.3mV.			
Torque control		Control input	Zero speed clamping input		
		Control output	Speed arrival		
		Analog quantity input	Torque command input	Analog torque command input , can conduct gain and polarity setting according to analog quantity voltage, with accuracy of 4.88mV	
			Speed limit input	Can conduct analog quantity speed limit	
	Speed limit	Can set speed limit with parameters			
	Torque command filter	Disposable delay filter of analog quantity input torque command			
Torque command null drift restrain	Support null drift restrain on external interference, with accuracy of 4.88mV.				
Internal position planning	Planning count	Support 16-dot internal position planning and communication control positioning			
	Path setting	1. Position; 2. Speed; 3. Acceleration time; 4. Deceleration time; 5. Stop timer; 6. Various status output; 7. Operating mode			
	Origin return	1. LS signal; 2. Z-phase signal; 3. LS signal + Z-phase signal; 4. Torque limit signal			
Protection	Hardware protection	Overvoltage, undervoltage, overcurrent, overspeed, overload, brake resistor overload, driver overheating, encoder fault, etc.			
	Software protection	Storage fault, initialization fault, I/O distribution abnormality, position deviation is too large, etc.			
	Protection and fault record	1. 10 faults can be recorded. 2. Key parameters at the occurrence of current fault can be recorded.			
Environment	Temperature	Working temperature	0~45°C		
		Storage temperature	-20~80°C(not freezing)		
	Humidity	Working/storage: ≤90%RH (without condensation)			
	IP grade	IP20			
	Altitude	<1000m			
Vibration	≤5.88m/s ² , 10~60Hz (working at the point of resonance is not allowed)				

Mechanical Dimensions of Servo Drive

220V series 100W/200W/400W

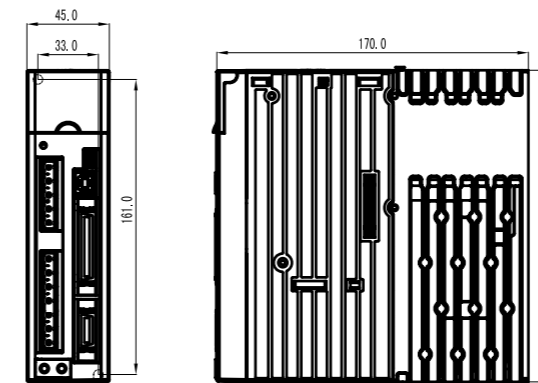

220V series 750W/1.0kW/1.5kW
380V series 1.0kW/1.5kW

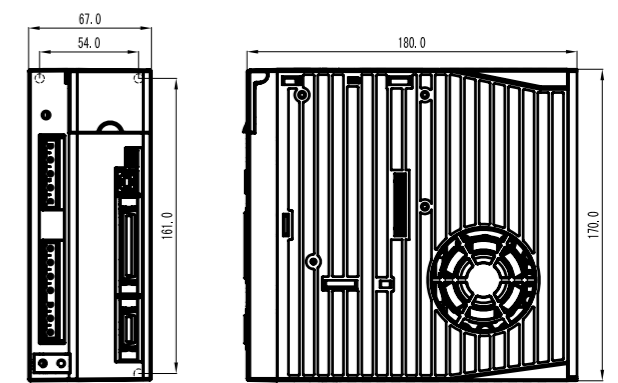

380V series 2.0kW/3.0kW

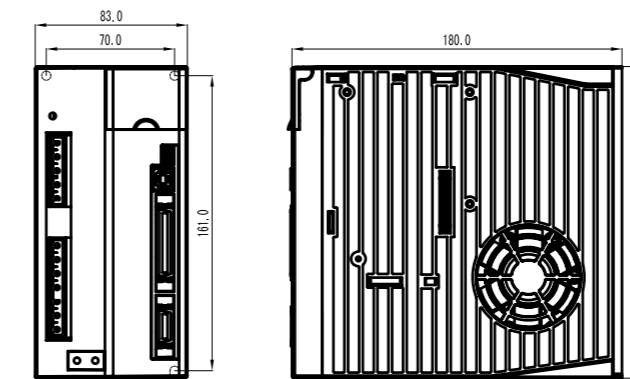

220V series 2.0kW/3.0kW
380V series 4.4kW/5.5kW

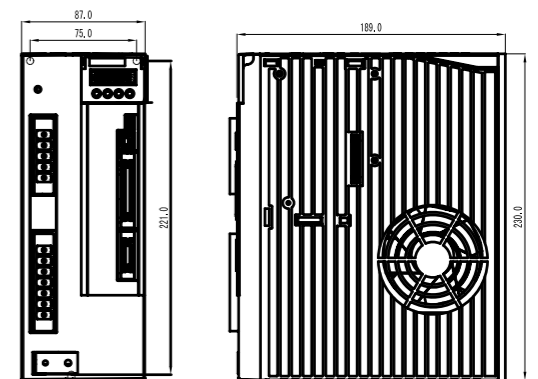

Communication extension module

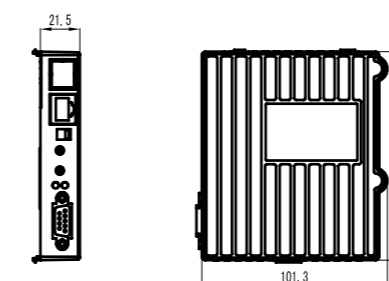

Servo Motor Type Description

S V - M L 0 6 - 0 R 4 G - 2 - 4 A 0
 ① ② ③ ④ ⑤ ⑥ ⑦ ⑧ ⑨

①

Symbol	Product Category
SV	Servo system

②

Symbol	Inertia Class
ML	Small
MM	Middle
MH	Large

③

Symbol	Seat No.
06	60
08	80
11	110
13	130
18	180

④

Symbol	Rated Power
0R2	200W
0R4	400W
0R7	750W
1R0	1.0kW
1R5	1.5kW
2R0	2.0kW
3R0	3.0kW
4R4	4.4kW
5R5	5.5kW

⑤

Symbol	Rated Rotating Speed
B	1500rpm
E	2000rpm
F	2500rpm
G	3000rpm

⑥

Symbol	Voltage Class
2	220VAC
4	380VAC

⑦

Symbol	Encoder type
1	2500ppr standard incremental type
2	2500ppr line-saving incremental type
3	17-bit one-loop absolute value type
4	17-bit multi-loop absolute value type

⑧

Symbol	Shaft End Connection
A	With key (standard)
B	No key

⑨

Symbol	Optional
0	With oil seal
1	Without optional
2	With oil seal and band-type brake
3	Only with band-type brake

60/80-Flange Servo Motor

Technical parameters of the motor

Motor series	220V,low power and small inertia			220V,low power and large inertia		
	SV-ML06-0R2G-2-□□□	SV-ML06-0R4G-2-□□□	SV-ML08-0R7G-2-□□□	SV-MH06-0R2G-2-□□□	SV-MH06-0R4G-2-□□□	SV-MH08-0R7G-2-□□□
Rated power kW	0.2	0.4	0.75	0.2	0.4	0.75
Rated current (A)	1.5	2.4	4.5	1.5	2.8	4.5
Maximum instant current (A)	4.5	7.2	13.5	4.5	8.4	13.5
Rated torque (Nm)	0.64	1.27	2.4	0.64	1.27	2.4
Maximum instant torque (Nm)	1.92	3.8	7.2	1.92	3.8	7.2
Rated rotating speed(rpm)	3000			3000		
Maximum rotating speed(rpm)	6000			6000		
Rotational inertia (Kg.cm ²)	0.21	0.32	1.26	0.42	0.67	2.5
Insulation grade	Class F(155°C)					
Protection level	IP65					
Working environment	Temperature: -20°C~50°C (not freezing); humidity: below 90%RH (without condensation)					

T-N curve

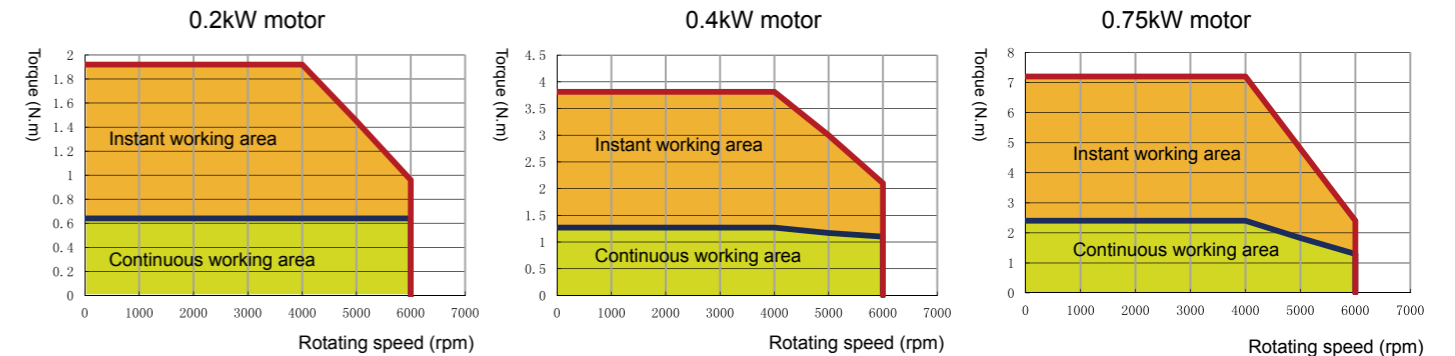

Mechanical dimensions

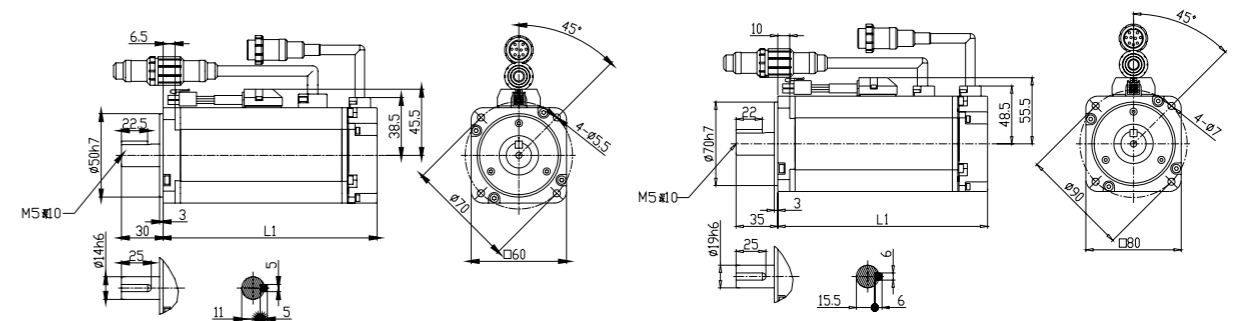

Model	0.2kW	0.4kW	0.75kW	0.2kW(large inertia)	0.4kW(large inertia)	0.75kW(large inertia)
L1 (without brake)	106	130	131	110	137	138
L1 (with brake)	140	164	176	/	/	/

130-Flange Servo Motor

Technical parameters of the motor

Motor series	220V, medium power and medium inertia				380V, medium power and medium inertia			
Motor model	SV-MM13-1R0E-2-□□□	SV-MM13-1R5E-2-□□□	SV-MM13-2R0E-2-□□□	SV-MM13-3R0E-4-□□□	SV-MM13-1R0E-4-□□□	SV-MM13-1R5E-4-□□□	SV-MM13-2R0E-4-□□□	SV-MM13-3R0E-4-□□□
Rated power (kw)	1	1.5	2	3	1	1.5	2	3
Rated current (A)	4.8	7.6	9.5	13.6	2.8	4.5	5.5	7.8
Maximum instant current (A)	14.4	22.8	28.5	40.8	8.4	13.5	16.5	23.4
Rated torque (Nm)	4.77	7.16	9.55	14.3	4.77	7.16	9.55	14.3
Maximum instant torque (Nm)	14.3	21.5	28.6	42.9	14.3	21.5	28.6	42.9
Rated rotating speed(rpm)	2000				2000			
Maximum rotating speed(rpm)	3000				3000			
Rotational inertia (Kg.cm ²)	6.3	9.36	12.16	18.02	6.3	9.36	12.16	18.02
Insulation grade	Class F(155°C)							
Protection level	IP65							
Working environment	Temperature: -20°C~50°C (not freezing); humidity: below 90%RH (without condensation)							

T-N curve

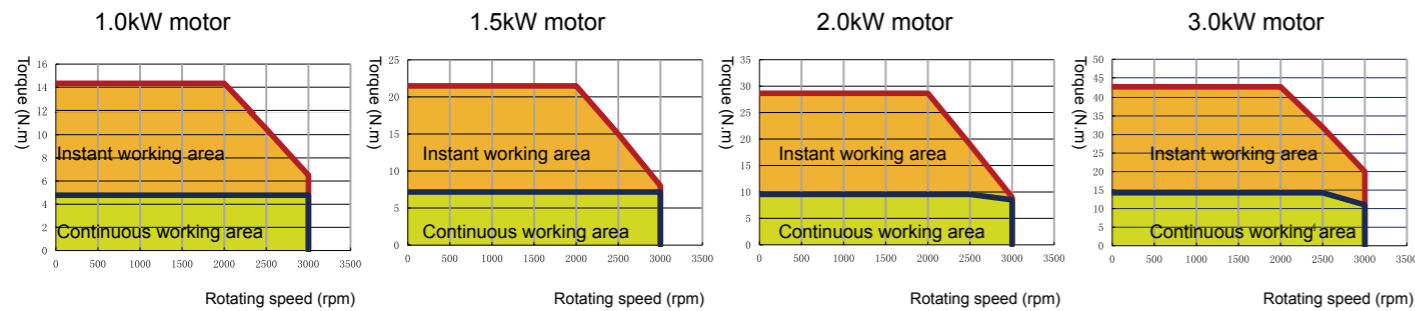

Mechanical dimensions

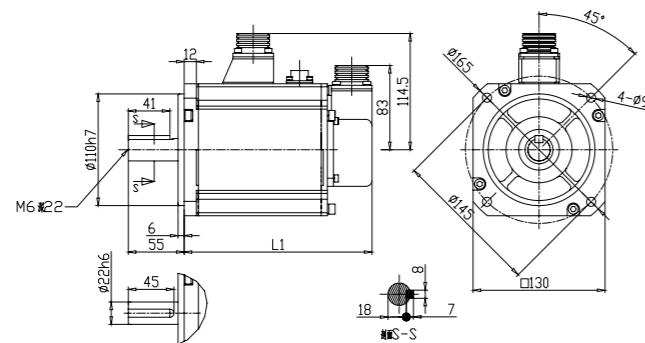

Model	1.0kW	1.5kW	2.0kW	3.0kW
L1 (without brake)	143	159	175	207
L1 (with brake)	185	201	217	249

180-Flange Servo Motor

Technical parameters of the motor

Motor series	380V, high power and medium inertia		
Motor model	SV-MM18-3R0B-4-□□□	SV-MM18-4R4B-4-□□□	SV-MM18-5R5B-4-□□□
Rated power (kw)	3	4.4	5.5
Rated current (A)	7.5	10	12
Maximum instant current (A)	18.75	25	30
Rated torque (Nm)	19	27	35
Maximum instant torque (Nm)	47	67	70
Rated rotating speed(rpm)	1500		
Maximum rotating speed(rpm)	2000		
Rotational inertia (Kg.cm ²)	38	61	86
Insulation grade	Class F(155°C)		
Protection level	IP65		
Working environment	Temperature: -20°C~50°C (not freezing); humidity: below 90%RH (without condensation)		

T-N curve

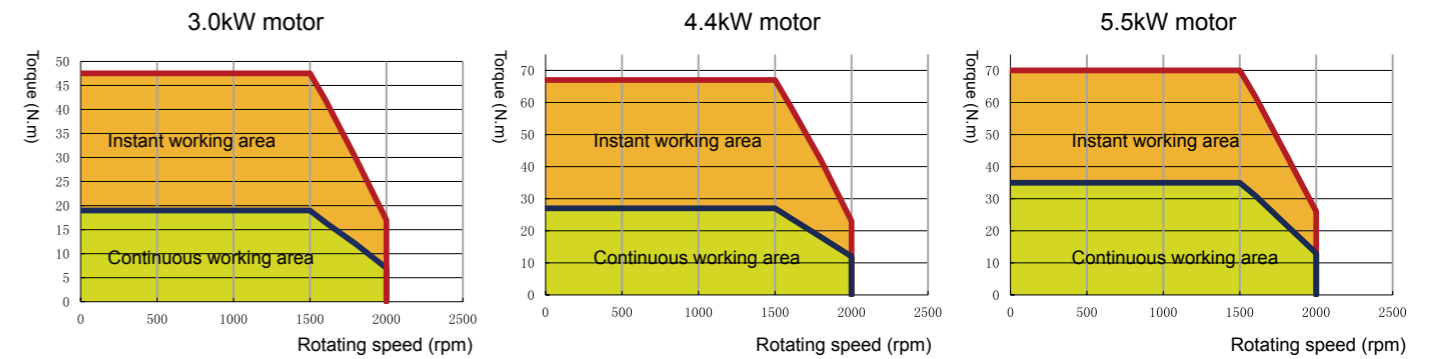

Mechanical dimensions

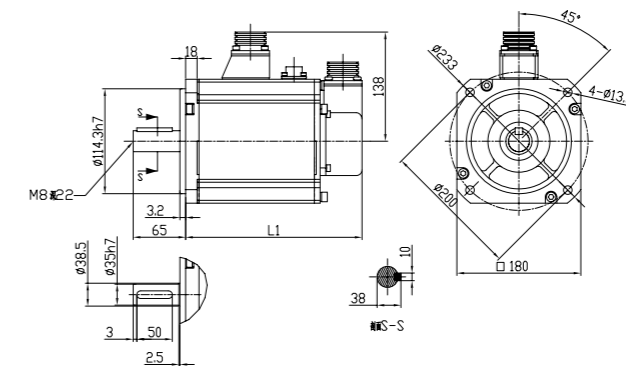

Model	3.0kW	4.4kW	5.5kW
L1 (without brake)	232	262	292
L1 (with brake)	289	319	349

Cable Type Description

Power cable

D A M L - 0 7 5 - 0 3 - A A F
 ① ② ③ ④ ⑤ ⑥ ⑦

①	Symbol	Supporting Series
	DB	DB100 series
	DA	DA100 series
②	Symbol	Cable Category
	ML	Power cable
	EL	Encoder cable
③	Symbol	Wire Diameter
	075	0.75mm ²
	100	1.0mm ²
	150	1.5mm ²
	250	2.5mm ²
④	Symbol	Cable Length
	03	3m
	05	5m
	10	10m
	15	15m
⑤	Symbol	Motor end plug
	DB	DB100 series
⑥	Symbol	Driver end plug
	DA	DA100 series
⑦	Symbol	Cable Texture
	Nil	Standard cable
	F	Flexible drag chain cable

Encoder cable

D A E L - 0 9 - 0 3 - A F
 ① ② ③ ④ ⑤ ⑥

①	Symbol	Supporting Series
	DB	DB100 series
	DA	DA100 series
②	Symbol	Cable Category
	ML	Power cable
	EL	Encoder cable
③	Symbol	Number of Cores
	06	6-core
	09	9-core
	15	15-core
④	Symbol	Cable Length
	03	3m
	05	5m
	10	10m
	15	15m
⑤	Symbol	Motor end plug
	DB	DB100 series
⑥	Symbol	Cable Texture
	Nil	Standard cable
	F	Flexible drag chain cable

Servo System Order Guide

Voltage	Power	Servo motor	Adaptive servo driver	Power cable Encoder cable	Plug-in fittings
220V	200W	SV-ML06-0R2G-2-□□□	SV-DA100-0R2-2-□	DAML-075-□□-CB□ DAEL-06-□□-C	DAML-CB DAEL-BC
	400W	SV-ML06-0R4G-2-□□□	SV-DA100-0R4-2-□		
	750W	SV-ML08-0R7G-2-□□□	SV-DA100-0R7-2-□		
	1.0kW	SV-MM13-1R0E-2-□□□	SV-DA100-1R0-2-□	DAML-150-□□-BB□ DAEL-06-□□-B	DAML-BB DAEL-BB
	1.5kW	SV-MM13-1R5E-2-□□□	SV-DA100-1R5-2-□		
		2.0kW	SV-MM13-2R0E-2-□□□	SV-DA100-2R0-2-□	DAML-150-□□-BD□ DAEL-06-□□-B
	3.0kW	SV-MM13-3R0E-2-□□□	SV-DA100-3R0-2-□		
400V	1.0kW	SV-MM13-1R0E-4-□□□	SV-DA100-1R0-4-□	DAML-150-□□-BB□ DAEL-06-□□-B	DAML-BB DAEL-BB
	1.5kW	SV-MM13-1R5E-4-□□□	SV-DA100-1R5-4-□		
	2.0kW	SV-MM13-2R0E-4-□□□	SV-DA100-2R0-4-□		
	3.0kW	SV-MM13-3R0E-4-□□□	SV-DA100-3R0-4-□	DAML-150-□□-BB□ DAEL-06-□□-B	DAML-BB DAEL-BB
	3.0kW	SV-MM18-3R0B-4-□□□			
	4.4kW	SV-MM18-4R4B-4-□□□	SV-DA100-4R4-4-□	DAML-250-□□-BD□ DAEL-06-□□-B	DAML-BD DAEL-BB
	5.5kW	SV-MM18-5R5B-4-□□□	SV-DA100-5R5-4-□		

Description:

- The servo system ordering have two options available to users: purchase standard finished cable or separately purchase plug-in fittings for self-preparation;
- Please select cable length (standard configuration of 3m, 5m, 10m and 15m) according to the actual demands of equipment.



MH500

Servo-Hydraulic System For Injection Molding Machines

Servo-Hydraulic System

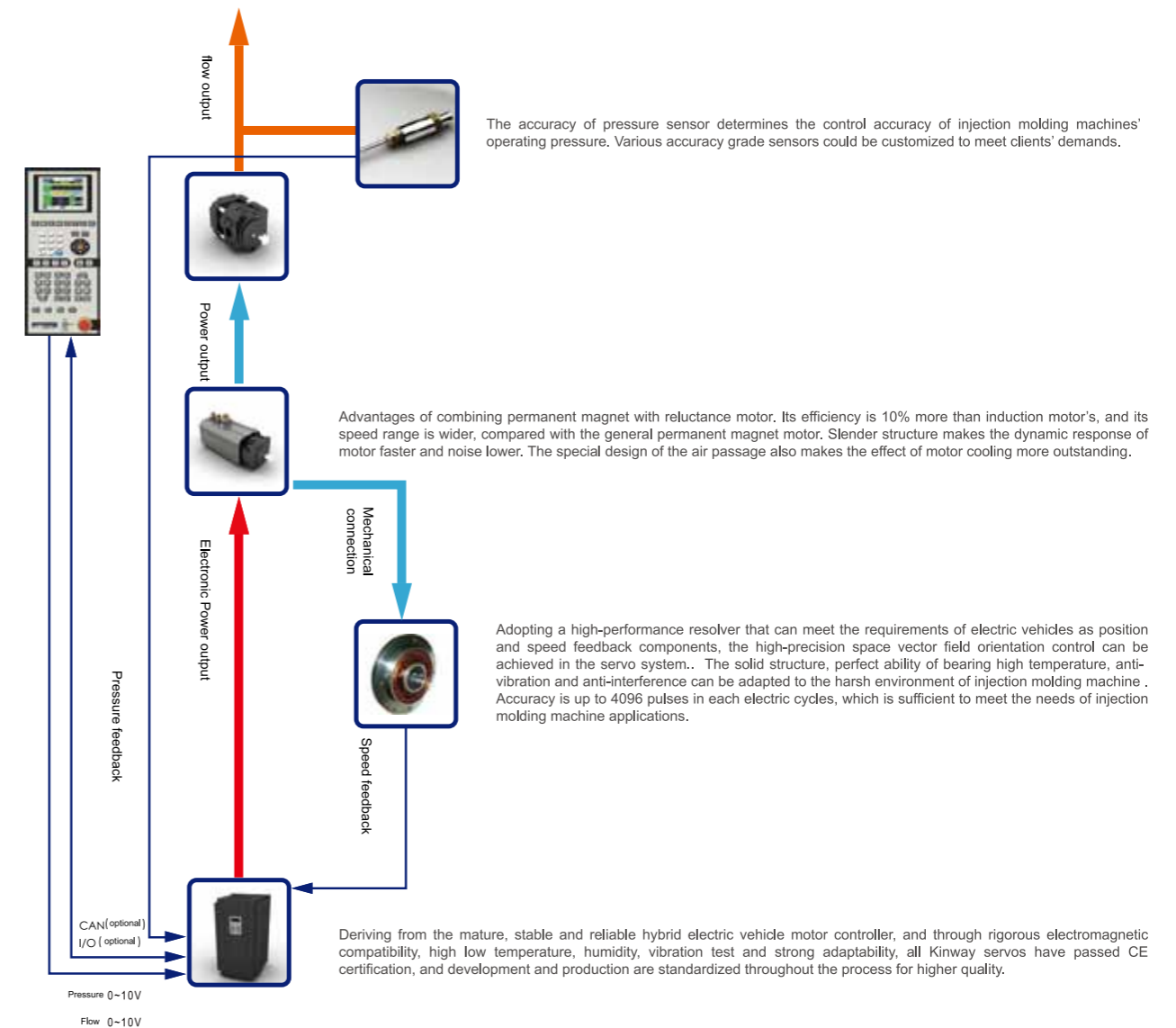
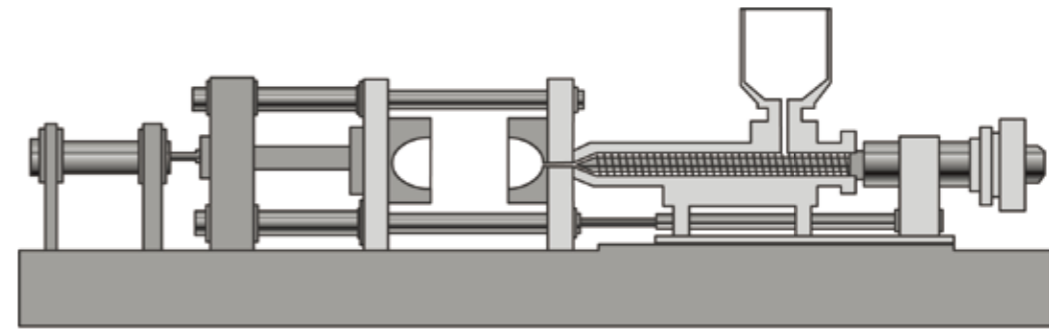

Servo-Hydraulic System for injection molding machine

Single System

Complete portfolio of Kinway servo-hydraulic system products provide servo systems of up to 45KW to meet the supporting requirements of plastic injection molding machine of below 400T.

Able to drive oil pump of 25 mL/r ~125 mL/r and to supply flow of 50 L/min ~ 250 L/min.

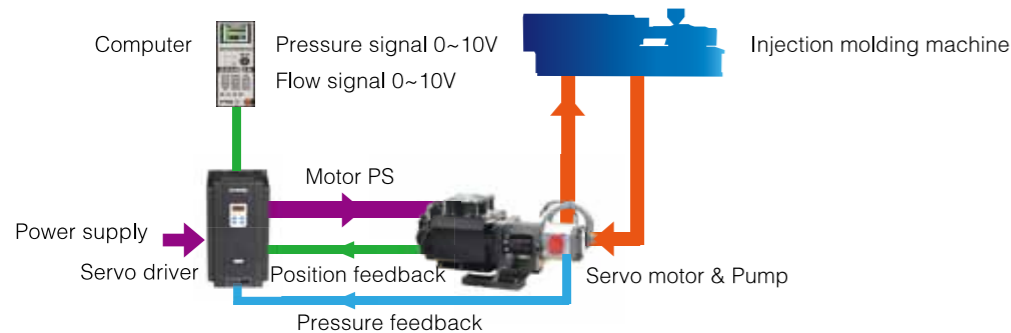

Multi System

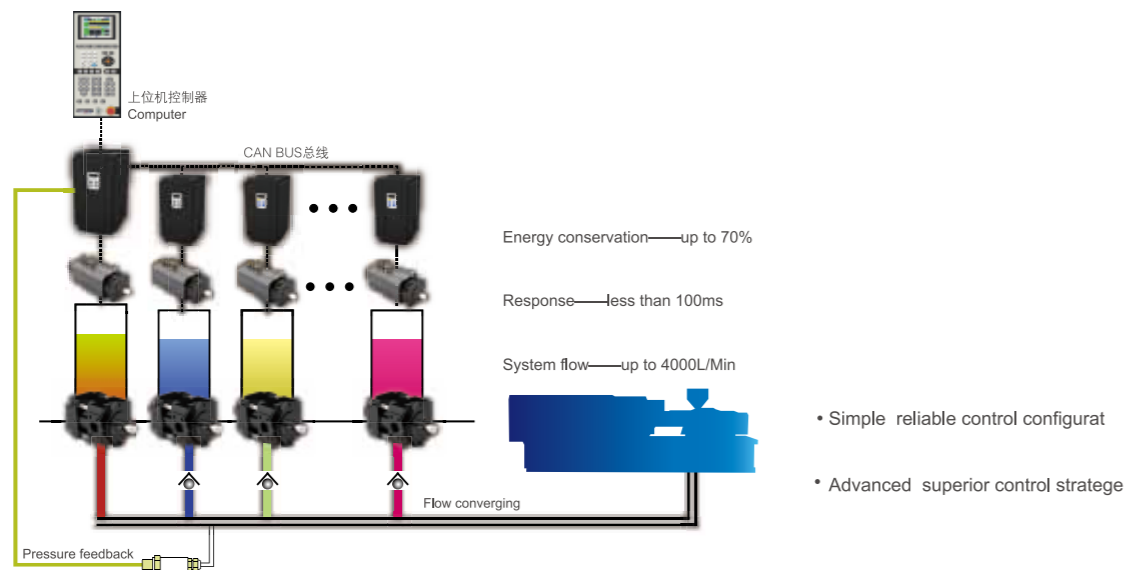

Multiple pump flow-converging products realize coordination control of all subsystems through CANBUS of servo controllers, put interflowed pressure as pressure feedback.

Given signals by upper-level computer, the main servo controller, through CANBUS, transmits digitalized commands to all other sub-servo controllers that have been set to optimized energy-saving levels based on their characteristics, all sub-servo systems optimize the torque and speed control of the motors to guarantee the quick responses and the stability of the system pressure and flow, as well as the smooth transition in all pumps. The multi pump flow-converging control system can realize 16 linkages in a single hydraulic loop at most, which makes the maximum flow of the machine up to 4000 L/min.

Selection

Pump selection

$$\text{capacity (mL/rev)} = \frac{\text{flow (L/m)} \times 1000}{\text{speed (r/m)}}$$

speed: the smaller value of maxium speeds of motor and pump
known: maxium pressure and flow in hydraulic system



Motor selection

$$\text{torque (N}\cdot\text{M)} = \frac{\text{pressure (MPa)} \times \text{flow (mL/rev)} \times 9.55}{\text{efficiency of mechanical} \times 60}$$

select a motor has the rated torque equals to half as maximum torque
known: maxium pressure and flow in hydraulic system



Driver selection

$$\text{Peak current (A)} = \frac{\text{rated current (A)} \times \text{Max pressure (MPa)}}{\text{consistant working pressure (MPa)}}$$

known: maxium pressure and flow in hydraulic system



please consult with INVT engineers to get optimized system configuration.

System Specification

Control signal

Control signal	Content
Input	4 inputs: ① servo enable(s-on) ② alarm clearance ③ 2optional inputs
Output	3 inputs: ① alarm output ② ready ③ I ₂ logic outputs
Communication(RS232C/RS48)	up-level controller 1:1 communication / up-level controller 1:n communication (n≤15)
Flow instruction input	command voltage: -10~+10V, input impedance: 2KΩ, digital input: RS485 CAN BUS
Pressure order input	command voltage: -10~+10V, input impedance: 2KΩ, digital input: RS485 CAN BUS

Controller specification

Controller specification	Content
Control mode	space vector field orientataion control, IGBT PWM control, Sinusoidal current driven
Application condition	use/storage temperature: -20~+45 /-20~+85 ,use/storage humidity: lower than90%RH(No Gel) Vaberation: 4.9m/s ² 19.6m/s ² ,Height: Lower than2000m
Working voltage	AC 380V±15%

Driver specification

Motor specification	Content
Type	AC Servo Motor
Operating temperature/Humidity	-20 ~ 45°C / 20 ~ 90% No Gel
Dielectric Voltage withstand/Resistance	AC 1500V 1min<5 mA/DC 1000V up to 50MΩ
Vibration level	0~100% load: Lower than ±0.1%(rated speed), rated voltage±15%:0%(rated speed)
Installing mode/Protected mode	Flange/Closed refrigeration IP55 (except axis)
The cable length of motor supply	2500 mm
The cable length of resolver	2500 mm

Breaking resistor specification

Resistance value	Power
15Ω	500W
10Ω	1000W
10Ω	2000W



MH500 Series Servo Driver Specifications

Servo Driver Model

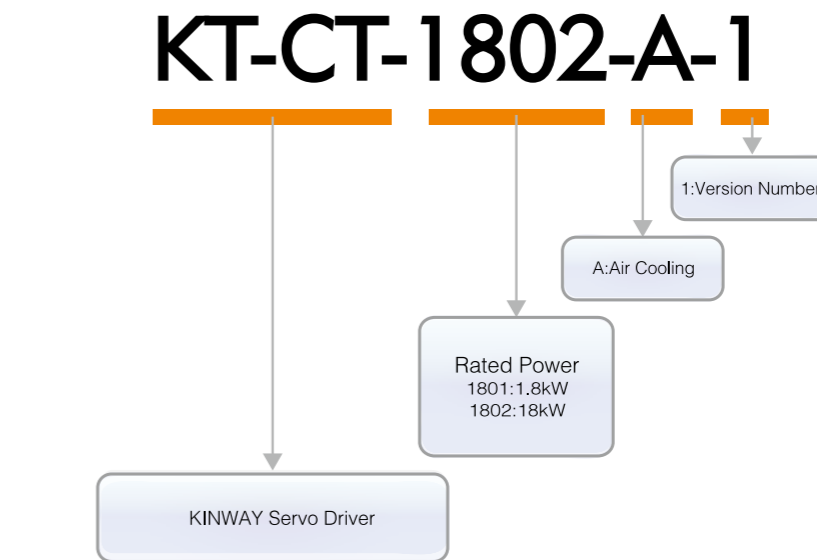

Model	Power	Rated Current	Peak Current (30s)	Peak Current (5s)
KT-CT-7501-A-0	7.5	15	30	38
KT-CT-1502-A-0	15	30	60	75
KT-CT-1802-A-1	18	35	72	100
KT-CT-2502-A-0	25	53	100	138
KT-CT-3502-A-0	35	75	140	188
KT-CT-4502-A-1	45	95	180	238

MH500 Series Servo Driver Dimension

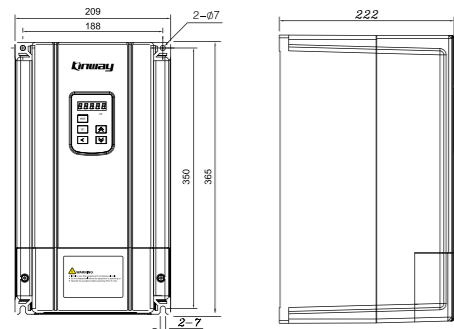

KT-CT-7501/1502/1802

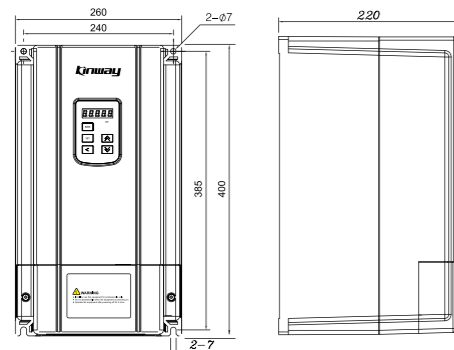

KT-CT-2502

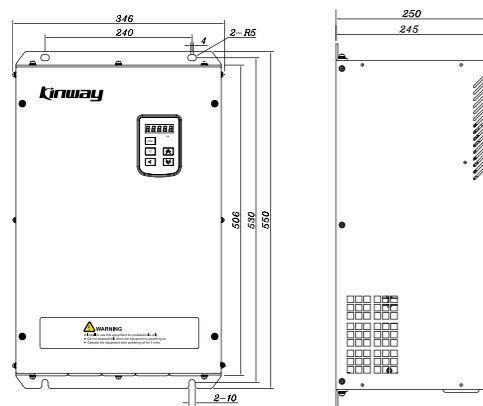

KT-CT-3502

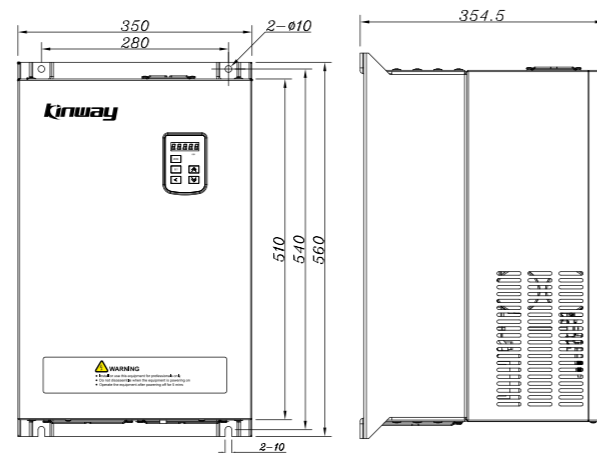

KT-CT-4502

Servo Motor Specifications

Servo Motor Model

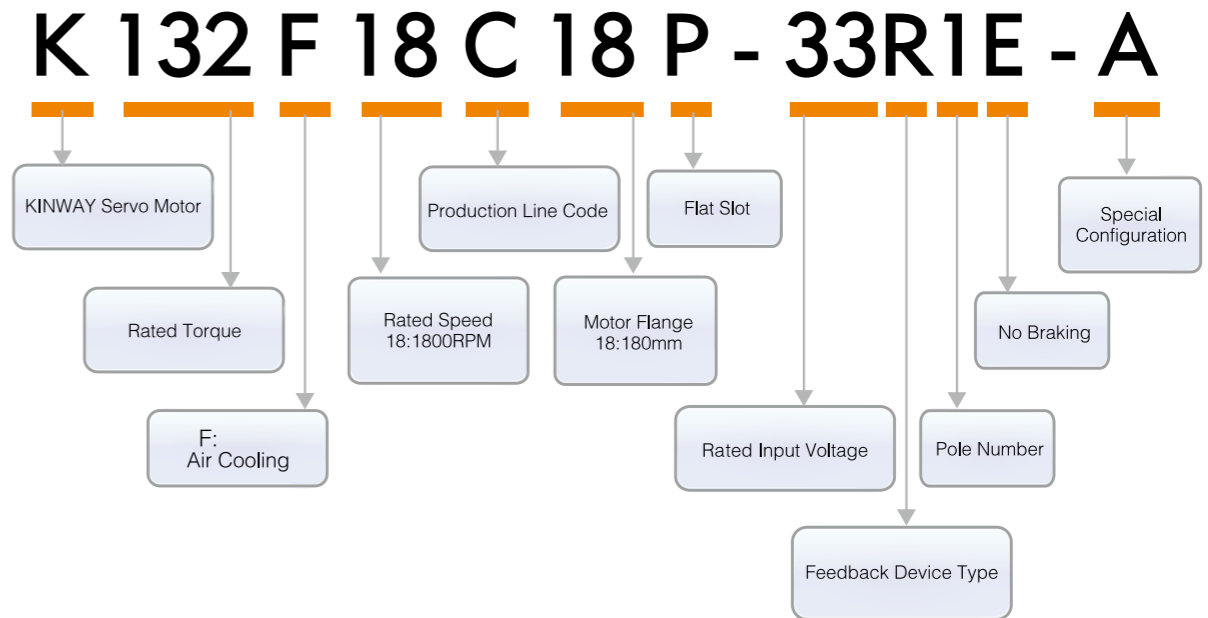

Model	Rated Power	Rated Speed	Max.Speed	Rated Torque
K038F18C18P-33R1E-A	7.5	1800	2500	38
K058F18C18P-33R1E-A	11	1800	2500	58
K072F18C18P-33R1E-A	13	1800	2500	72
K091F15C18P-33R1E-A	15	1500	2200	91
K111F15C18P-33R1E-A	18	1500	2200	111
K132F18C18P-33R1E-A	25	1800	2500	132
K187F18C25P-33R1E-A	35	1800	2500	187

Servo Motor Dimension

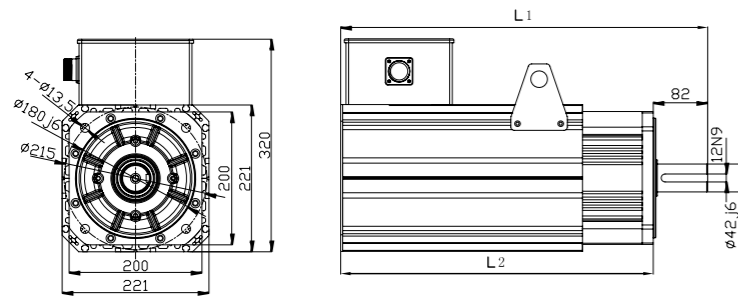

Model	Length	
	L1	L2
K038F18C18P-33R1E-A	412.5	330.5
K058F18C18P-33R1E-A	447.5	365.5
K072F18C18P-33R1E-A	482.5	400.5
K091F15C18P-33R1E-A	517.5	435.5
K111F15C18P-33R1E-A	552.5	470.5
K132F18C18P-33R1E-A	622.5	540.5

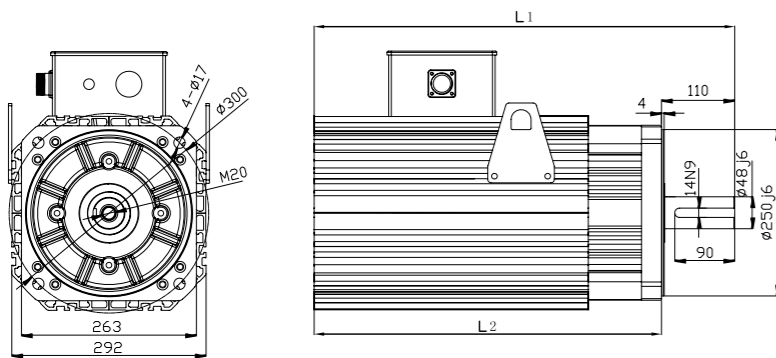

Model	Length	
	L1	L2
K187F18C25P-33R1E-A	632	520
K235F20C25P-33R1E-A	719	607

System interconnect diagram

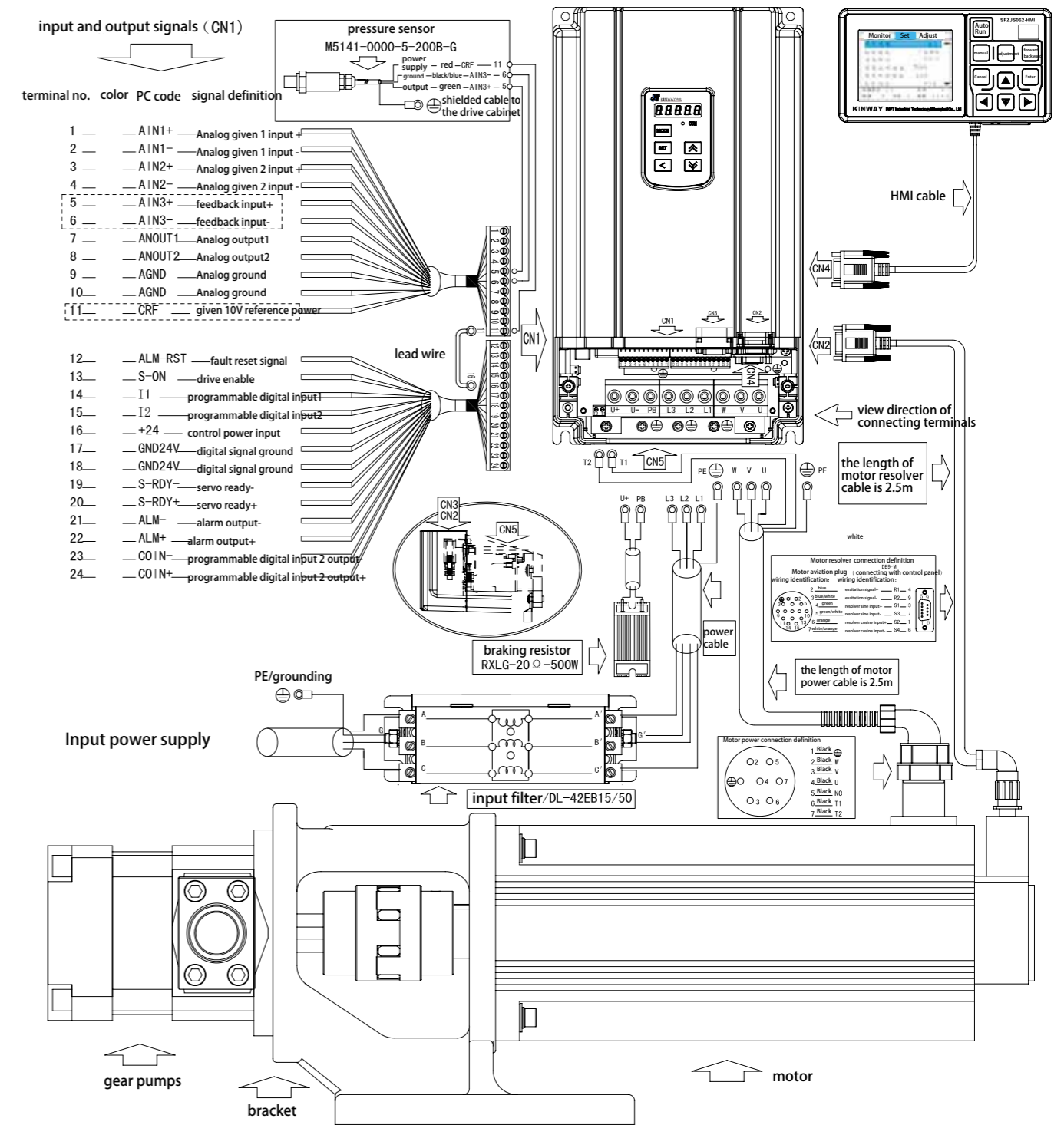

This figure is only the connection diagram of KT-CT-7501-A-0/KT-CT-1502-A-0/KT-CT-1802-A-0/KT-CT-2502-A-0, which is the same with other connection type of controllers. If you need details, please contact our company.

Successful Cases

Servo system for 850 tons plastic injection molding machine



Control cabinet(contain controller)

Servo motor

The configuration of the electro hydraulic servo system:

- Driver ——2×KT-CT-2502-A (25KW)
- Motor ——2×U1013F.20.3 (37KW)
- Pump ——2×90 mL/rev

Notes: "2*"means two pcs

The flow output is up to 360L/m

Servo improvement of 250T plastic injection molding machine

The configuration of the electro hydraulic servo system:

- Driver ——2xKT-CT-2502-A-1(25KW)
- Motor —— 2xK132F18C18P(25KW)
- Pump —— 2x80cc/rev

Energy saving Test

	conventional system	Servo-Hydraulic System
Testing Time	3	3
Cycle Times	98	98
3hours Energy Consumption	35.9	15.8
1day Energy Consumption	287	126.4
1year Energy Consumption	91904	40448
1year Energy Costs	73523	32358
Energy Conservation		60.0
Oil Temperature Rise	5	2
Machine Noise	82	78

Precision Test

No.	Product weight	Opening mould position (set 250)	Decompression value at end of injection (set 0)	Decompression value at end of plasticizing (set 0)
1	234	299	31.5	190.7
2	234.5	298.4	31.3	190.6
3	234	298.3	30.5	190.7
4	234.5	298.9	30.8	190.7
5	234.5	298.3	30.9	190.4
6	234	298.3	30.6	190.7
7	234.5	298.3	30.8	190.6
8	234	298.5	30.9	190.6
9	234	298.3	30.8	190.5
10	234	298.4	30.6	190.4

Energy conservation 60.0%

Save ¥41165 in one year

The repeatability of the weight of the product over 2‰

Sales & Service Network

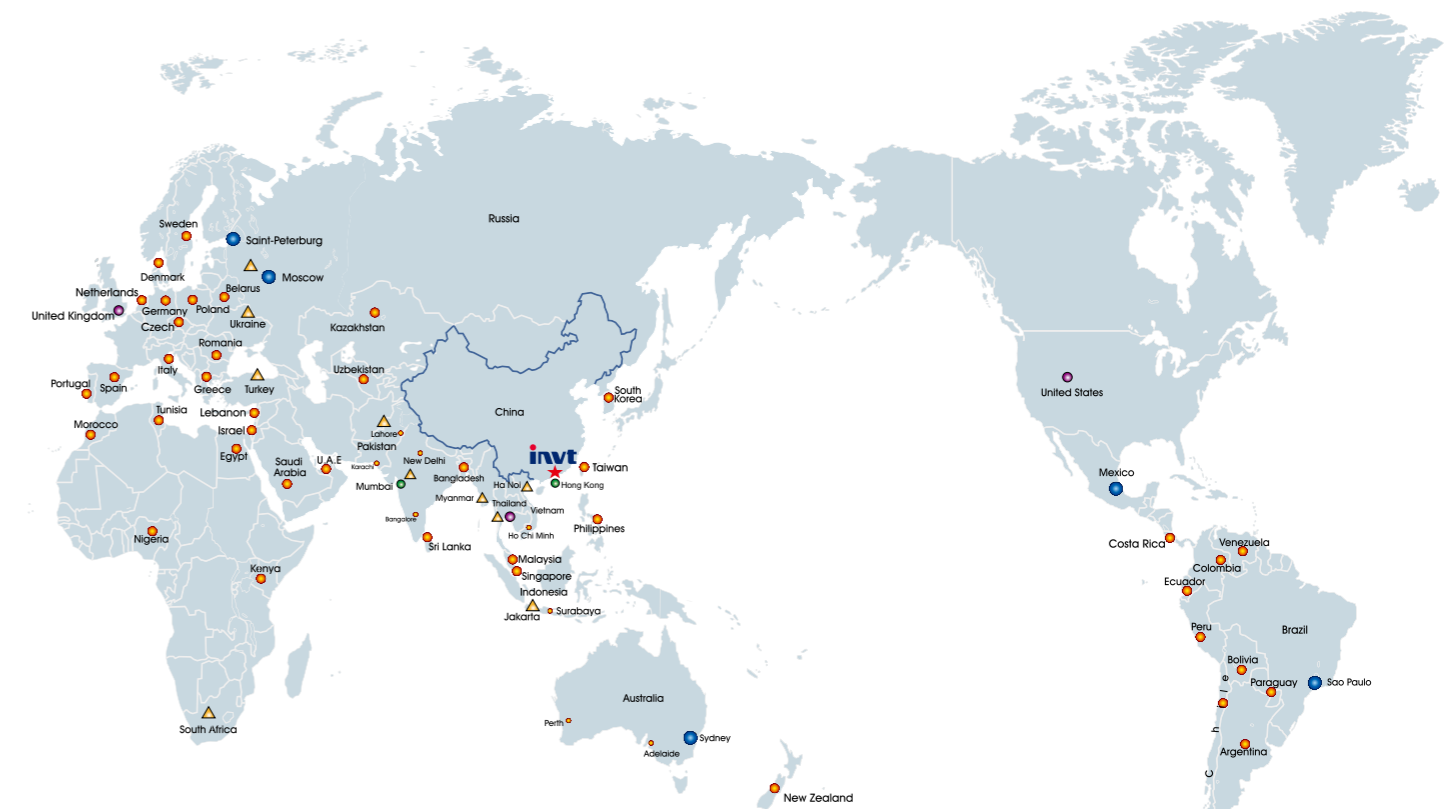

- ★ Headquarter: Shenzhen INVT Electric Co., Ltd
- Subsidiary: INVT Electric India Pvt.Lt ; INVT INTERNATIONAL TRADING LIMITED
- Established Office: St. Petersburg、Moscow、Sydney、Mexico City、Sao Paulo
- Ready-to-Establish Office: USA、Thailand、UK
- ▲ Global Service Center: Turkey、Pakistan、Ukraine、Vietnam、Russia、Indonesia、Thailand、India、South Africa、Myanmar
- Sales Country: Exported to Italy、South Africa、UAE、Ukraine、Argentina etc.more than 60 countries and regions