



NEVER STOP IMPROVING



Shenzhen Inovance Technology Co., Ltd.

Add.: Building E, Hongwei Industry Park, Liuxian Road,
Baocheng No. 70 Zone, Bao'an District, Shenzhen
Tel: +86-755-2979 9595
Fax: +86-755-2961 9897
Service Hotline: 400-777-1260
<http://www.inovance.cn>

Suzhou Inovance Technology Co., Ltd.

Add.: No. 16, Youxiang Rd, Yuexi Town, Wuzhong District,
Suzhou 215104, P.R. China
Tel: +86-512-6637 6666
Fax: +86-512-6285 6720
Service Hotline: 400-777-1260
<http://www.inovance.cn>

Contact info of agency

Copyright © Inovance, All Rights Reserved.

Inoprec

IS620P Series High-Performance Servo System



About INOVANCE



Inovance Suzhou Factory (Phase-2)

Shenzhen Inovance Technology Co., Ltd. (Stock code: 300124) is a leading industrial automation product and solution provider, dedicated to R&D, manufacturing and sales of automation control products. Targeting at high-end equipment manufacturers, we are committed to achieving a win-win situation with customers based on our solid automation control technologies with IPRs. We have maintained a mature business model through which customized solutions have been constantly and rapidly delivered to customers.

Our offering provides low/mid-voltage AC drives, PLCs, HMIs, servo drives, motors, photoelectric encoders, integrated and special drives, and renewable energy products, etc. We are now taking up the largest market share in domestic low-voltage section and have obtained a leading position in various segmentation markets with our all-round integrated and special drives.

As a national high-tech enterprise, we have obtained quite a number of patents. Till the end of 2012, there are 121 invention patents, 112 utility model patents, 32 design patents and 49 software copyrights authorized or applied. Besides, we have mastered various core platform technologies covering the fields of high-performance vector control inverter, PLC, servo, and PMSM. Attracting and cultivating talents is our constant pursuit. Till now, Inovance has already owned a large group of professional R&D experts dedicated to development of core platform technologies, application technologies and new products.

Service Network

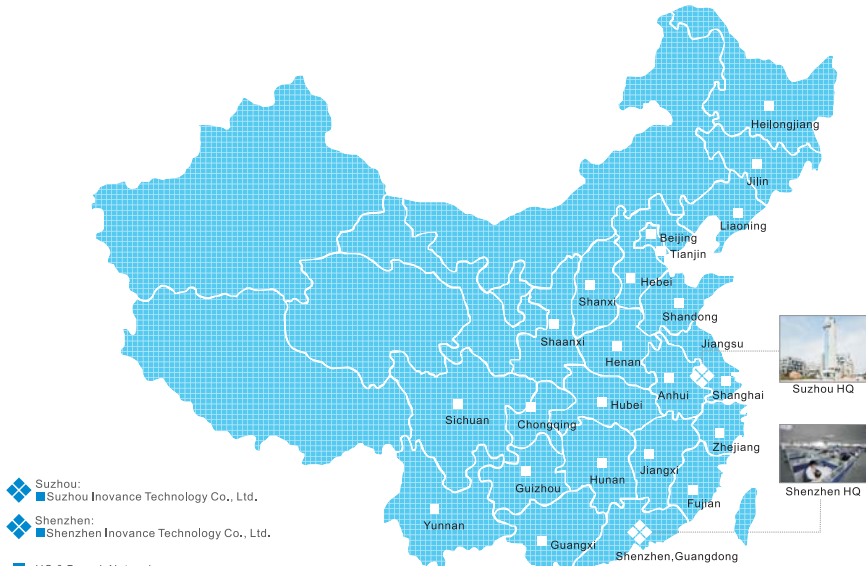

- ◆ Suzhou: Suzhou Inovance Technology Co., Ltd.
- ◆ Shenzhen: Shenzhen Inovance Technology Co., Ltd.

HQ & Branch Network
 Headquarter in Shenzhen and Suzhou, with a number of subsidiaries in HK, Hangzhou, etc
 66 offices throughout China
 Over 400 sales and service engineers
 236 authenticated distributors
 90 nationwide warranty centers
 8 spare parts centers
 Quickly respond to customer needs.

Platform Advantages

Inovance has set up R&D and manufacturing bases both in Shenzhen and Suzhou cities, and established subsidiaries in HK, Hangzhou, Taizhou, Changchun, and etc, which focus on different industries.

Suzhou Inovance Technology Co., Ltd.

Suzhou Inovance Technology Co., Ltd. is dedicated to R&D and manufacturing of integrated elevator controllers, servo drives, medium voltage AC drives, and etc. It has such advantages as IPD based on customer requirements, excellent solution expertise, all-round service system, advanced SCM management, outstanding quality control process, ERP and OA platforms.

Jiangsu Huicheng Motor Co., Ltd.

Huicheng manufactures ISMH high-response servo motors, ISMG medium-power servo motors, ISMD torque motors and gradually enters the fields of EV motors and integrated motors. This motor subsidiary enhances Inovance's competency and competitiveness of providing comprehensive solutions

Changchun Huitong Optoelectronic Co., Ltd. (Weton)

Weton is dedicated to developing and manufacturing incremental and absolute optical encoders, speed sensors, photoelectric switches, magnetic induction switches, inductance proximity switches, hall switches, liquid level switches, simple light curtains, blazed grating protectors, brakes, brake starters, escalator sensors, and etc.

Inovance Servo Drives

Servo Product Structure

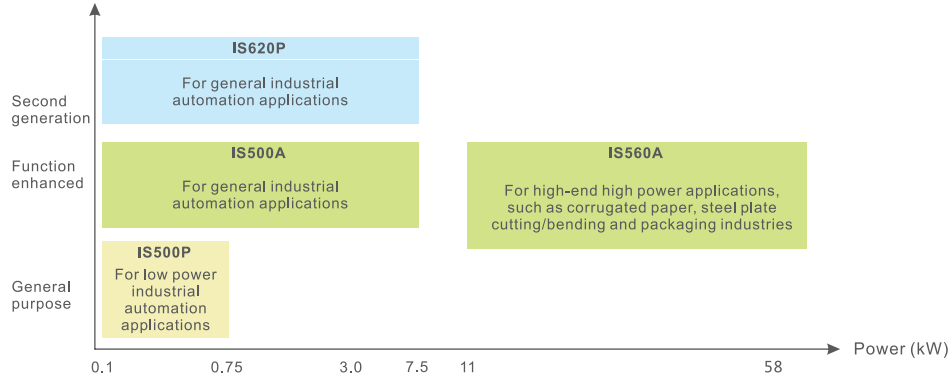

Servo System Overview

IS500 servo drive system	IS560 servo drive system	IS620P servo drive system
<p>Applications</p> <p>Textile equipment, electronic manufacturing equipment, LED industry, printing industry, cable equipment, linear manipulator, food production line, packaging production line, detection equipment, lithium industry, winding machine, material feeding equipment, ceramic equipment, injection molding machinery, glass machinery</p>	<p>Applications</p> <p>Bending machine, straightening machine, paper cutting machine, steel plate cutting machine, printing and dyeing equipment, packaging machinery, large manufacturing equipment, etc.</p>	<p>Applications</p> <p>Engraving and milling machine, carving machine, specular machine, CNC, machine tool, miller, grinder, wood carving machine, glass machine, wire cutting, electric spark, welding and cutting equipment, warp knitting machine, electronic manufacturing equipment, LED industry, lithium equipment, joint manipulator, printing industry, cable equipment, line manipulator, food production line, packaging production line, detection equipment, winding machine, material feeding machine, ceramic equipment, injection molding machine, glass machine</p>
<p>Features</p> <p>Excellent responsiveness, online/off-line inertia identification, rigid table setting, manual/automatic notch filter setting, gain switchover, interruption fixed length, home return, in-built 16-position setting, in-built 16-speed setting, start-on-fly protection, high startup torque, overload protection, over-current protection, virtual I/O, Modbus communication, customizable CANopen and CANlink3.0 (developed by Inovance) communication, full closed-loop control, electronic cam, gantry synchronization, etc</p>	<p>Features</p> <p>Self-adaptive adjustment of current-loop parameters of third-party motors, excellent responsiveness, full closed-loop control, gain switchover, interruption fixed length, home return, in-built 16-position setting, in-built 16-speed setting, start-on-fly protection, high startup torque, overload protection, virtual I/O, Modbus communication, customizable CANopen and CANlink3.0 (developed by Inovance) communication, electronic cam, gantry synchronization, etc</p>	<p>Features</p> <p>Excellent responsiveness (1.2 kHz speed loop band width), 4 Mpps differential position pulse input, 4 Mpps differential position feedback output, 20 bit encoder, online/off-line inertia identification, rigid table setting, manual/automatic notch filter setting, gain switchover, friction/torque compensation, speed/torque feedforward, interruption fixed length, home return, in-built 16-position setting, in-built 16-speed setting, start-on-fly protection, high startup torque, overload protection, over-current protection, virtual I/O, Modbus communication, customizable CANopen and CANlink3.0 (developed by Inovance) communication, full closed-loop control, electronic cam, gantry synchronization, etc</p>

Performance Characteristics of IS620P servo Drive

IS620P Servo System



High performance

- Response frequency 1.2 kHz
- 20 bit incremental encoder: 1.04 million pulses per revolution
- Input/Output pulses: 4 Mpps
- Analog reference resolution: 16 bit (1/65536) (customized function)
- Low cogging torque
- Overload capacity up to 3 times

Intelligent

- Load inertia identification
- Automatic identification of motor parameters
- Convenient gain adjustment
- Automatic/Manual notch filter
- Automatic/Manual damping filter

Full specifications

- Full range of servo drives from 100 W to 7.5 kW; small/medium-inertia servo motors for options

Safe

- Optional safe torque off (STO) function
- Motor IP level IP65/67, satisfying water-proof and dust-proof requirements
- CE certified

Practical

- Disturbance torque compensate gain & filter time
- PDF control coefficient (H08-24)
- Various communication modes
- Tailored motors for path tracking control
- Downsized servo drives and motors
- Friction/Torque compensate
- Braking energy treatment
- Torque limit switchover
- Gain switchover
- I/O signal distribution

Rich application functions

- Dual-PG full closed-loop control
- Interrupted position control
- Gain switchover
- Electronic cam control
- Gantry synchronization
- Multi-position control

High Performance

- Leading performance in the industry, fully qualified for path tracking control applications, such as metal engraving and milling machine, processing center, CNC machine tool, grinder, electric spark, welding & cutting, wire cutting, etc.
- Qualified for applications that require fast positioning, such as die bonder, chip mounter, spectral machine, punching machine feeder, wire-stripping machine, warp knitting machine

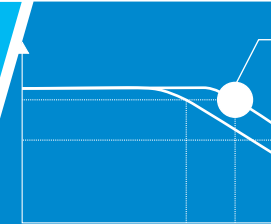

Response frequency 1.2 kHz

Applications: LED industry, lithium industry, manipulator, machine tool

- High response control based on torque feedforward can reduce response delay. Optimal adjusting time of position can reach 1 ms.

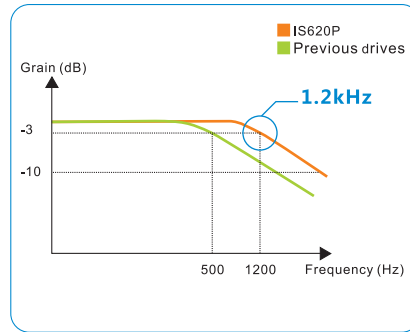

20 bit incremental encoder: 1.04 pulses per revolution

Applications: machine tool, electronic manufacturing equipment, wood carving machine, packaging equipment, detection equipment, glass machinery

- Vibration during stop decreases as the actions are performed smoothly. Positioning precision reaches up to $(\pm 1/1048576) \times 360^\circ$. Besides, the motor runs more smoothly.

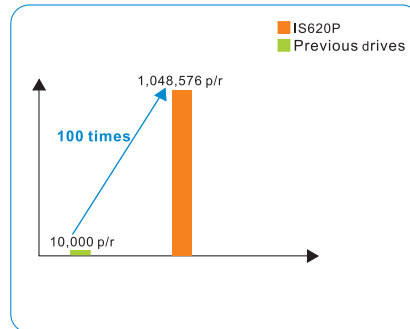

Input/Output pulses: 4 Mpps

Applications: machine tool, manipulator, robot

- Both reference input and feedback output frequencies can reach up to 4 Mpps. Full closed-loop control operation can also be performed at high resolution.

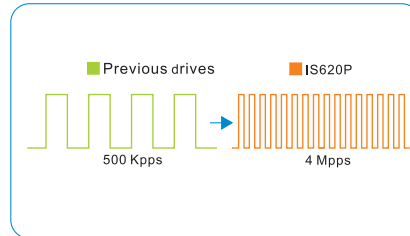

Analog reference resolution: 16 bit (1/65536)

Applications: engraving and milling machine, glass machinery, electronic manufacturing equipment

- IS620P series servo drive is configured with two analog channels AI1 and AI2 to satisfy both general and high precision analog reference requirement. Resolution of AI1 is 12 bit; resolution of AI2 can be selected as 12 bit or 16 bit via software switch.

Note: Analog reference with 16 bit high precision resolution is a customized function.

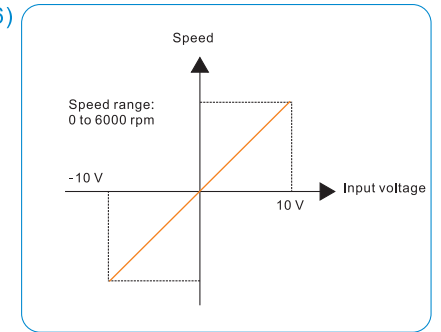

Low cogging torque

Applications: grinder, welding & cutting machine, wire cutting machine, electric spark equipment

- The optimal combination of motor's poles and slots can significantly reduce fluctuation of torque during power-on. Besides, the positioning torque can be decreased, which ensures more stable and smooth operation.

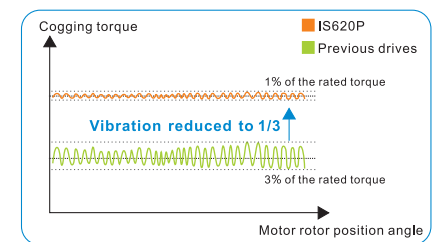

Overload capacity up to 3 times

Applications: LED equipment, manipulator, cable equipment

- Overload capacity of the ISMH1/H2/H4 series servo motors can reach up to 3 times; that of the ISMH3 series servo motor 2.5 times.

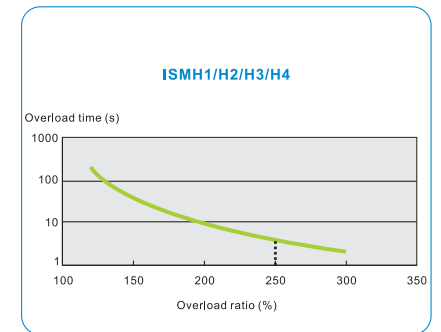

Intelligent

- Commissioning is simplified. Excellent performance can be realized by simply adjusting the rigidity level, providing that online inertia identification and automatic notch filter functions are enabled.
- Oscilloscope with continuous sampling and DI/DO monitoring can be conducted on the background software, which facilitates commissioning and fault location.

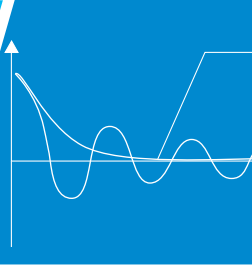

Automatic identification of motor parameters

- The IS620P can identify motor parameters automatically, bringing convenience of use.

Load inertia identification

- There are on-line and off-line inertia identification modes. Setting values of most parameters can reach their optimal status after automatic identification. This can shorten system adjusting time to a large scale.



Convenient gain adjustment

- Speed loop and position loop gains can be automatically adjusted by setting the rigidity level. This could reduce difficulties of commissioning for different industries.

Automatic/Manual notch filter

- The vibration frequency can be automatically detected and notch filter can be automatically set. This will significantly reduce noise and vibration generated due to devices' mechanical resonance, thus realizing fast response actions.

- The IS620P series servo drive is configured with 4 notch filters, setting frequency of which ranges from 50 to 4000 Hz.

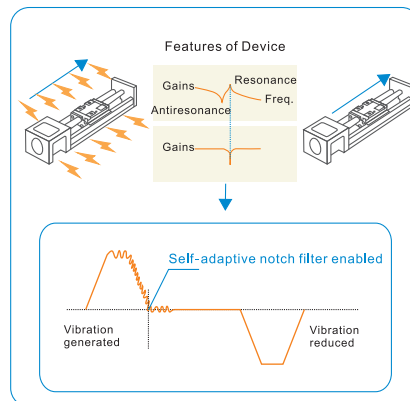

Automatic/Manual damping filter

- By inputting filter commands, the damping filter can help eliminate the inherent vibration frequency and thus largely reduce swinging of shaft during stop. Applicable frequency ranges from 1 to 100 Hz.

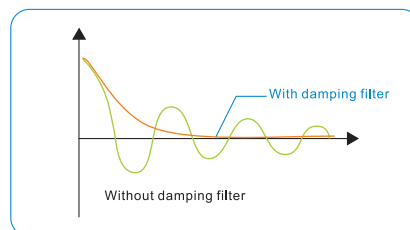

Full Specifications

- Able to satisfy 90% market requirements, Medium inertia servo motors are specially suitable for path tracking control applications, such as manipulators and engraving and milling

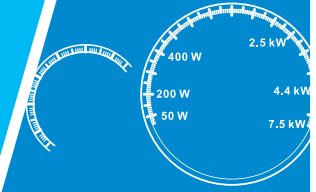

Full range of servo drives from 100 W to 7.5 kW; small/medium-inertia servo motors for options

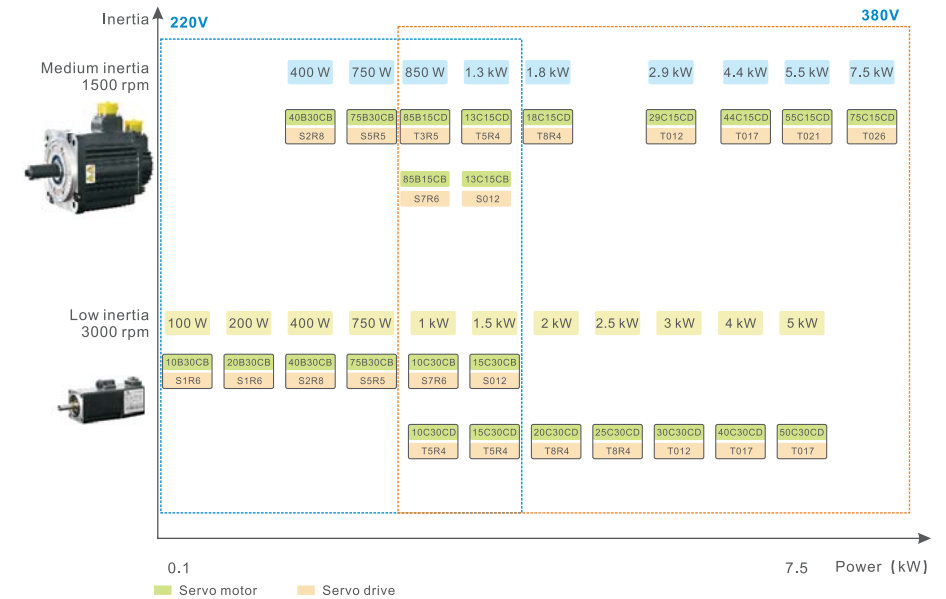

Safe

- Compliant to international safety standards, Inovance servo motors are designed with high IP protection level, making them safe and reliable.



Optional safe torque off (STO) function

- The STO function is a safety function. With this function, drive signals of power transistor are forcibly blocked by safety input signals to cut off motor current, and the motor output torque is then closed.

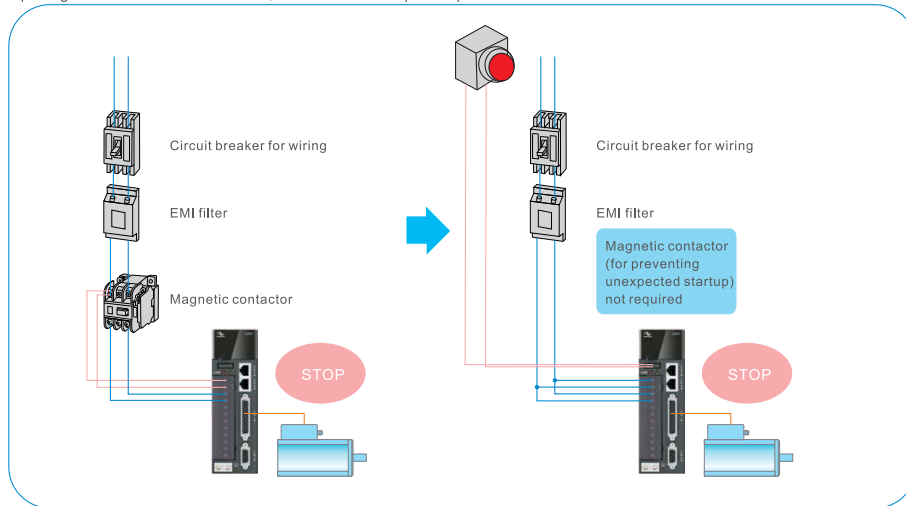

Motor IP level IP65/67, satisfying water-proof and dust-proof requirements

- Motors are designed with standard oil seal. IP level reaches IP67 (except for the shaft end).



CE compliance

- CE certified

Practical

- Practical and easy to use, with various functions



Disturbance torque compensation gain (H09-30) & filter time (H09-31)

- Compensation to the torque reference is conducted after detecting the acceleration of the mechanical system and estimating the disturbance torque attached on the system. This is effective when there is external disturbance. Besides, tracking of torque reference can be enhanced. This function also works on an vertical axis.

Effect of using torque disturbance observer on the vertical axis



■ Speed reference ■ Speed feedback
 Note: Diagram on the left is captured without using the torque disturbance observer; Diagram on the right is captured based on setting H09-30 to 100% and H09-31 to default 0.5 ms.

PDFF control coefficient (H08-24)

- The PDFF coefficient is set to 100% (PI control) by default. If it is set to a value other than 100%, external disturbance resistance control is performed. This can be used to increase the capability of resisting external forces and improve speed response waveforms.

Improvement of speed rising and positioning by PDFF coefficient



■ H08-24=100%: Speed rises slowly; Positioning time: 162 ms
 ■ H08-24=80%: Speed tracking is good; Positioning time: 89 ms

Various communication modes

- Support Modbus, CANlink, CANopen and EtherCAT (CANlink, CANopen and EtherCAT customized functions).

Low/medium-power medium-inertia motors specially designed for path tracking control applications

- Guarantee smooth running and precise positioning.

Downsized servo drives and motors

- Length of motors is shortened by 1/5; size and weight of servo drives are decreased by 1/3.

Braking energy treatment

- When a relatively large inertia load stops, the braking energy released from the servo motor to the servo drive can be consumed by braking resistors.

Gain switchover

- Two groups of gains can be switched over based on different conditions. This will shorten the positioning time and reduce vibration.

Friction/Torque compensation

- Friction torque compensation functions to improve the capability of response by reducing mechanical friction. This will decrease difficulties of programming for applications such as arc surface processing, Z axis operation and ball screw mechanism.

Torque limit switchover

- Torque limit switchover can be performed via I/O. This function can be used for simple pressure and tension control applications.

I/O signal distribution

- Nine DIs and five DOs can be allocated at random via parameter setting. The background software provides a dedicated operating interface, which makes it much easier.

Rich Application Functions

Dual-PG full closed-loop control

Function description:

The encoder installed on the velocity measurement roller feeds back the signal of materials' actual position. The servo drive then conducts closed-loop position control via this signal to ensure that the materials are delivered accurately and smoothly to the preset position. This can effectively reduce slipping materials and the conveyor, and properly adjust gaps between transmission actions.

The dual-PG full closed-loop control function is realized by the algorithm inside the servo drive. The smoothness of speed and position control during material transmission can be adjusted by the filter embedded in the drive. Besides, runaway protection functions when the difference between positions of the internal and external loops is large. This ensures smooth and reliable transmission of materials.

Application examples:

Steel plate cutting
Pipe bending machine
Wire-stripping machine

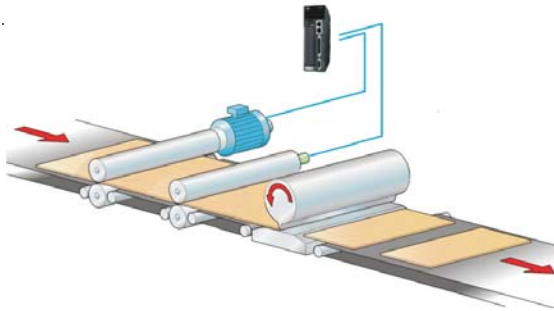

Interrupted position control

Function description:

The servo drive runs in the position control mode, and the interruption fixed length function is enabled. After an external DI interruption signal is input, the motor immediately continues to run to the fixed length at its existing speed. This function is at top priority. When it is enabled, corresponding operation actions instantly, thus bring short time delay. During the period of executing this function, the servo drive does not respond to other position commands, which prevents influence of other commands on the fixed length function.

Application examples:

Material layout mechanism
Longitudinal line cutter
Bearing tube cutting

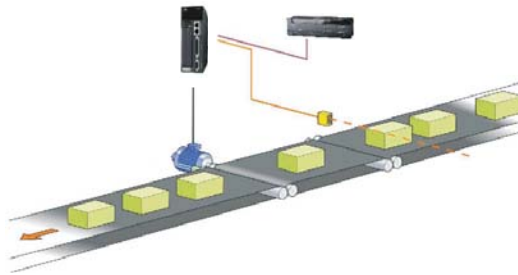

Gain switchover

Function description:

Switchover between two groups of gain parameters is realized judging by optional various conditions (external DI, torque reference, speed reference, speed reference change rate, speed reference high/low-speed thresholds, position deviation, position reference, etc.). Different gain parameters are used before and after the load or transmission mechanism changes. This ensures stable operation and good performance of the system under different working conditions.

System stability during gain switchover can be guaranteed by properly setting the gain switchover delay, level and hysteresis.

Application examples:

Manipulator
Woods rotary cutter

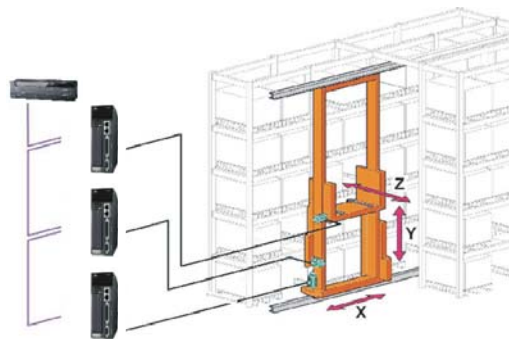

Electronic cam control

Function description:

The encoder installed on the velocity measurement roller feeds back the signal of materials' actual speed and position. The servo drive uses these signals for the master axis, and plans a position curve for the slave axis (servo motor). The servo motor then runs based on this curve. This function simulates mechanical cam in an electronic way, in order to reduce mechanical input and easily realize change of cam curves. Thus, there is no need to maintain and change mechanical cams.

Rotary cutting, flying cutting and flying saw functions can be easily realized.

Application examples:

Printing machinery
Flying cutting of panels

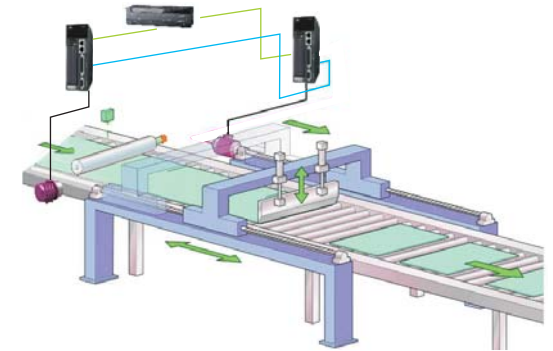

Gantry synchronization

Function description:

The host sends pulse reference to two servo drives simultaneously. Encoders on the two servo motors feed back position pulses. The servo drives interact and cross-couple these pulse signals to adjust speeds of the motors in real time, so that the two axes are synchronized. Dual-axis drive control can be used in applications where there are large gantry structures, to reduce mechanical coupling.

The virtual synchronization controllers inside the servo drives reports alarm when the position deviation exceeds the preset limit. The entire system then stops running.

Application examples:

Large planing machine
Welding and cutting equipment
Glass processing

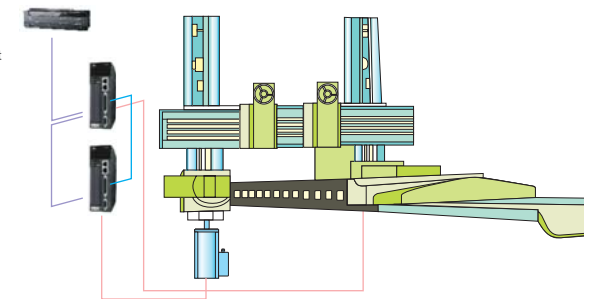

Multi-position control

Function description:

Up to 16-position control can be realized through different combinations of input terminals, by selecting different in-built position reference. (Various groups of position signals can be set through function codes of the servo drive manually or via host communication.) To use this function, servo motor installed with multi-ring absolute encoder is required and the home return operation needs to be performed.

Multi-position control function helps simply design of the host. During the period of executing multi-position control, position reach signals are output when each section is completed.



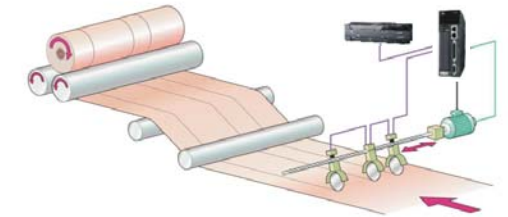

Application examples:



Longitudinal line cutter
Multi-station transfer mechanism
Servo tool rest



Reference	1	2	3	4	5	6	n
Home	1	2	3	4	5	6	n
Position	1	2	3	4	5	6	n

Servo Drive System Overview

		Single-phase 220V			Three-phase 220V				
Servo Drive									
	SIZE A						SIZE C		
	IS620PS1R6I	IS620PS2R8I	IS620PS5R5I			IS620PS5R5I	IS620PS7R6I	IS620PS012I	
Servo Motor									
	10B30CB 20B30CB	40B30CB	75B30CB			75B30CB	85B15CB 10C30CB	13C15CB 15C30CB	

		Three-phase 380V						
Servo Drive								
	SIZE C				SIZE E (※)			
	IS620PT3R5I	IS620PT5R4I	IS620PT8R4I	IS620PT012I	IS620PT017I	IS620PT021I	IS620PT026I	
Servo Motor								
	85B15CD	13C15CD 10C30CD 15C30CD	18C15CD 20C30CD (※) 25C30CD (※)	29C15CD 30C30CD (※)	40C30CD (※) 44C15CD (※) 50C30CD (※)	55C15CD (※)	75C15CD (※)	

Note: Models marked with "※" are in development.

Servo Motor Overview

Designation Rules

① ISM H1-75B 30C B-U2 3 1 Z

① Product series: ISM servo motor	④ Rated speed (rpm): A: x1 B: x10 C: x100 D: x1000 E: x10000 Example: 15B indicates 150 rpm; 30C indicates 3000 rpm.	⑦ Shaft connection mode: 1: Protruding shaft 3: Solid shaft with key and thread
② Feature: H1: Low inertia, small capacity H2: Low inertia, medium capacity H3: Medium inertia, medium capacity H4: Medium inertia, small capacity	⑤ Voltage level: B: 200 V D: 400 V	⑧ Brake, gear box & oil seal: 0: None 1: Oil seal 2: Brake 4: Oil seal + brake
③ Rated power (W): A: x 1 B: x 10 C: x 100 D: x 1000 E: x 10000 Example: 75B indicates 750 W; 15C indicates 1500 W.	⑥ Encoder type: U2: 20 bit bus-type encoder	⑨ Series: Y: Y series Z: Z series

Motor Specifications

Model	Rated Output* (kW)	Rated Torque* (N·m)	Max. Instant Torque* (N·m)	Rated Current* (A)	Max. Instant Current* (A)	Rated Speed* (min ⁻¹)	Max. Speed* (min ⁻¹)	Torque Constant (N·m/A)	Rotor Rotation Inertia (x10 ⁻⁴ kg·m ²)	Volt. (V)		
ISMH1 (Vn = 3000 rpm, Vmax = 6000 rpm)												
ISMH1-10B30CB-U2□□Z	0.1	0.318	0.954	1.50	4.41	3000	5000	0.213	0.046 (0.048)	200		
ISMH1-20B30CB-U2□□Z	0.2	0.637	1.91	1.60	5.80				6000		0.45 (0.163)	
ISMH1-40B30CB-U2□1Z	0.4	1.27	3.82	2.80	10.10		0.51 0.25					
ISMH1-75B30CB-U2□1Z	0.75	2.39	7.16	4.60	15.10		0.57 1.3					
ISMH2 (Vn = 3000 rpm, Vmax = 6000/5000 rpm)												
ISMH2-10C30CB-U2□□Y	1.0	3.18	9.54	7.50	23.00	3000	6000	0.43	1.87 (3.12)	200		
ISMH2-15C30CB-U2□□Y	1.5	4.90	14.7	10.8	32.00				5000		2.46 (3.71)	
ISMH2-10C30CD-U2□□Y	1.0	3.18	9.54	3.65	11.00		6000				0.87 (3.12)	
ISMH2-15C30CD-U2□□Y	1.5	4.90	14.7	4.48	14.00				5000		1.09 (2.46)	
ISMH2-20C30CD-U2□1Y	2.0	6.36	19.1	5.89	20.00		5000				1.08 3.06	
ISMH2-25C30CD-U2□1Y	2.5	7.96	23.9	7.56	25.00				5000		1.05 3.65	
ISMH2-30C30CD-U2□1Y	3.0	9.8	29.4	10.00	30.00		5000				0.98 7.72	
ISMH2-40C30CD-U2□1Y	4.0	12.6	37.8	13.60	40.80				5000		0.93 12.1	
ISMH2-50C30CD-U2□1Y	5.0	15.8	47.6	16.00	48.00	5000	1.07 15.4					
ISMH3 (Vn = 1500 rpm, Vmax = 3000 rpm)												
ISMH3-85B15CB-U2□□Y	0.85	5.39	13.5	6.60	16.50	1500	3000	0.6	13 (15.5)	200		
ISMH3-13C15CB-U2□□Y	1.3	8.34	20.85	10.00	25.00				5000		0.66 (21.8)	
ISMH3-85B15CD-U2□□Y	0.85	5.39	13.5	3.30	8.25						3000	1.2 (15.5)
ISMH3-13C15CD-U2□□Y	1.3	8.34	20.85	5.00	12.50				3000			1.32 (21.8)
ISMH3-18C15CD-U2□□Y	1.8	11.5	28.75	6.60	16.50						3000	1.37 (28)
ISMH3-29C15CD-U2□□Z	2.9	18.6	45.1	11.90	28.00				3000			1.70 (57.2)
ISMH3-44C15CD-U2□□Z	4.4	28.4	71.1	16.50	40.50		3000			1.93 (90.8)		
ISMH3-55C15CD-U2□□Z	5.5	35.0	87.6	20.80	52.00				3000	1.80 (109.5)		
ISMH3-75C15CD-U2□□Z	7.5	48.0	119	25.70	65.00		3000			1.92 (143.1)		
ISMH4 (Vn = 3000 rpm, Vmax = 6000 rpm)												
ISMH4-40B30CB-U2□□Z	0.4	1.27	3.82	2.80	10.10		3000		6000	0.51	0.653 (0.667)	200
ISMH4-75B30CB-U2□□Z	0.75	2.39	7.16	4.60	15.10						0.57 (2.033)	

Notes: ① Motors configured with oil seal shall be used by de-rating 10% of rated power.
② Values inside () are for motors configured with brake.

Servo Motor Overview

Mounting Dimensions of Servo Motor

ISMH1 Series

100 W (Vn = 3000 rpm, Vmax = 5000 rpm)

Connector	Power Side (incl. Power Brake Side)	Encoder Side
Plastic housing	MOLEX-50361672	AMP172169-9
Terminal	MOLEX-39000059	AMP1473226-1

Motor Model	LL (mm)	LG (mm)	TP (mm)	Weight (kg)
ISMH1-10B30CB-U2□□Z	104.5 (137.6)	5	M3 x 6	0.59 (0.77)

200 W, 400 W (Vn=3000 rpm, Vmax = 6000 rpm)

Connector	Power Side (incl. Power Brake Side)	Encoder Side
Plastic housing	MOLEX-50361672	AMP172169-9
Terminal	MOLEX-39000059	AMP1473226-1

Motor Model	LL (mm)	LG (mm)	TP (mm)	Weight (kg)
ISMH1-20B30CB-U2□□Z	98 (136)	7.6	M5 x 8	1.1 (1.4)
ISMH1-40B30CB-U2□1Z	118			1.6

750 W (Vn = 3000 rpm, Vmax = 6000 rpm)

Connector	Power Side (incl. Power Brake Side)	Encoder Side
Plastic housing	MOLEX-50361672	AMP172169-9
Terminal	MOLEX-39000059	AMP1473226-1

Motor Model	LL (mm)	LG (mm)	TP (mm)	Weight (kg)
ISMH1-75B30CB-U2□1Z	135.5	7.8	M6 x 10	2.7

Note: Values inside () are for those motors configured with brake.

Mounting Dimensions of Servo Motor

ISMH2 (Vn = 3000 rpm, Vmax = 6000/5000 rpm) Series

1.0 kW, 1.5 kW, 2.0 kW, 2.5 kW

Connector	Power Side (incl. Power Brake Side)	Encoder Side
Aviation plug	MIL-DTL-5015 series 3102E20-18P	MIL-DTL-5015 series 3102E20-29P

Motor Model	LL (mm)	LG (mm)	TP (mm)	Ka1 (mm)	Ka2 (mm)	Kb1 (mm)	Kb2 (mm)	Weight (kg)
ISMH2-10C30CB(D)-U2□□Y	164 (216)	10	M8 x 16	96	74	94.5 (101)	143.5 (192.5)	5.11 (6.41)
ISMH2-15C30CB(D)-U2□□Y	189 (241)					119.5 (128)	168.5 (219.5)	6.22 (7.52)
ISMH2-20C30CD-U2□1Y	214					144.5	193.5	7.39
ISMH2-25C30CD-U2□1Y	239					169.5	218.5	8.55

3.0 kW, 4.0 kW, 5.0 kW

Connector	Power Side	Encoder Side
Aviation plug	MIL-DTL-5015 series 3102E20-18P	MIL-DTL-5015 series 3102E20-29P

Motor Model	LL (mm)	LG (mm)	TP (mm)	Ka1 (mm)	Ka2 (mm)	Kb1 (mm)	Kb2 (mm)	Weight (kg)
ISMH2-30C30CD-U2□1Y	209.5	14	M8 x 20	111	74	136	188.5	10.73
ISMH2-40C30CD-U2□1Y	252					178.5	231	15.43
ISMH2-50C30CD-U2□1Y	294.5					221	273.5	16.2

Note: Values inside () are for those motors configured with brake.

Servo Motor Overview

Mounting Dimensions of Servo Motor

ISMH3 (Vn = 1500 rpm, Vmax = 3000 rpm) Series

850 W, 1.3 kW, 1.8 kW

Connector	Power Side	Power Brake Side	Encoder Side	Diagram					
Aviation plug	MIL-DTL-5015 series 3102E20-18P	MIL-DTL-5015 series 3102E10SL-4P	MIL-DTL-5015 series 3102E20-29P						
Motor Model	LL (mm)	LG (mm)	TP (mm)	KA1 (mm)	KA2 (mm)	KB1 (mm)	KB2 (mm)	Weight (kg)	
ISMH3-85B15CB(D)-U2□□Y	168.5 (227.5)	14	M6 x 20	111	74	95 (80)	147.5 (191.5)	8.23 (10.73)	
ISMH3-13C15CB(D)-U2□□Y	194.5 (253.5)					121 (106)	173.5 (217.5)	10.57 (13.0)	
ISMH3-18C15CD-U2□□Y	220.5 (279.5)					147 (132)	199.5 (243.5)	12.7 (15.2)	

2.9 kW, 4.4 kW, 5.5 kW, 7.5 kW

Connector	Power Side (incl. Power Brake Side)	Encoder Side	Diagram										
Aviation plug	MIL-DTL-5015 series 3102E20-22P	MIL-DTL-5015 series 3102E20-29P											
Motor Model	LL (mm)	LR (mm)	LW (mm)	S (mm)	RH (mm)	WK (mm)	W (mm)	TP (mm)	KA1 (mm)	KA2 (mm)	KB1 (mm)	KB2 (mm)	Weight (kg)
ISMH3-29C15CD-U2□□Z	197 (273)	79	65	35	30	10 [°] _{±0.08}	10 [°] _{±0.02}	M12 x 25	138	74	136 (186)	177 (305)	20.9 (32)
ISMH3-44C15CD-U2□□Z	230 (307)										169 (241)	210 (360)	29.4 (40)
ISMH3-55C15CD-U2□□Z	274 (350)	113	96	42	37	12 [°] _{±0.03}	12 [°] _{±0.027}	M16 x 32	138	74	213	254	34.5 (42.5)
ISMH3-75C15CD-U2□□Z	330 (407)										269	310	43.2 (62.5)

Note: Values inside () are for those motors configured with brake.

Mounting Dimensions of Servo Motor

ISMH4 (Vn = 3000 rpm, Vmax = 6000 rpm) Series

400 W

Connector	Power Side (incl. Power Brake Side)	Encoder Side	Diagram				
Plastic housing	MOLEX-50361672	AMP172169-9					
Terminal	MOLEX-39000059	AMP1473226-1					
Motor Model	LL (mm)	LG (mm)	TP (mm)	Weight (kg)			
ISMH4-40B30CB-U2□□Z	125 (163)	7.6	M5 x 8	1.7 (2.0)			

750 W

Connector	Power Side (incl. Power Brake Side)	Encoder Side	Diagram				
Plastic housing	MOLEX-50361672	AMP172169-9					
Terminal	MOLEX-39000059	AMP1473226-1					
Motor Model	LL (mm)	LG (mm)	TP (mm)	Weight (kg)			
ISMH4-75B30CB-U2□□Z	146.5 (183.5)	7.8	M6 x 10	2.9 (3.3)			

Note: Values inside () are for those motors configured with brake.

Servo Motor Overview

Torque/Speed Characteristics of Servo Motor

ISMH1 (low inertia, small capacity)

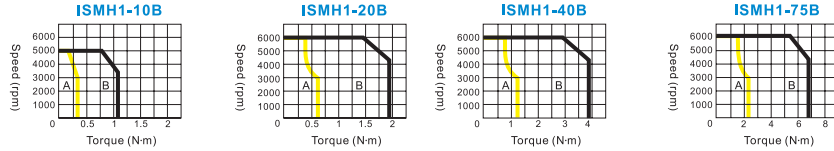

ISMH2 (low inertia, medium capacity)

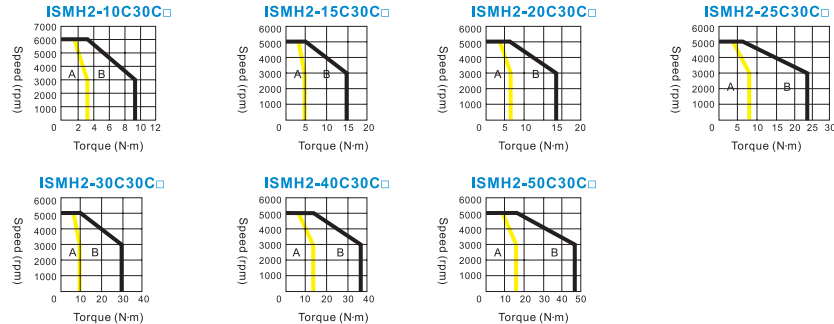

ISMH3 (medium inertia, medium capacity)

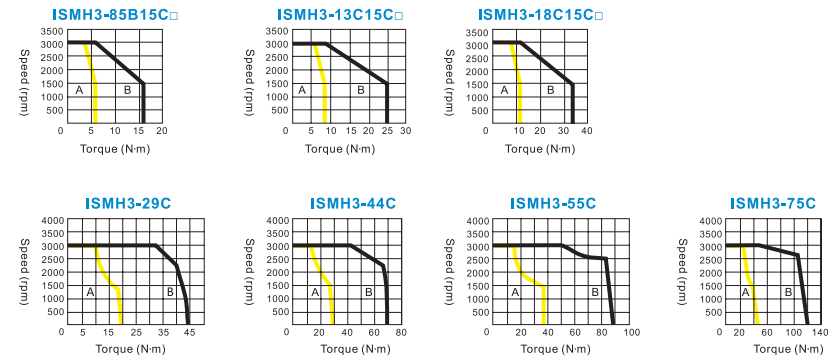

ISMH4 (medium inertia, small capacity)

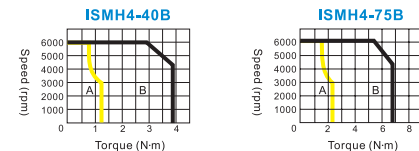

Note: A (continuous duty zone), B (intermittent duty zone).

Overload Characteristics of Servo Motor

ISMH1/H2/H3/H4

Load Ratio	RUN time (s)
120	230
130	80
140	40
150	30
160	20
170	17
180	15
190	12
200	10
210	8.5
220	7
230	6
240	5.5
250	5
300	3

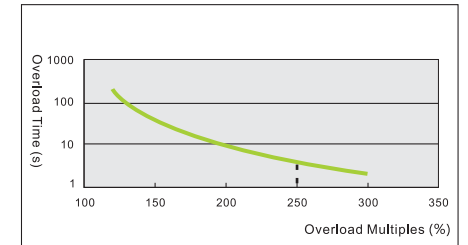

Note:
H1/H2/H4 series: up to 3 times;
H3 series: up to 2.5 times

Allowable Radial/Axial Load of Servo Motor

Motor Model	Allowable Radial Load (N)	Allowable Axial Load (N)
ISMH1-10B30CB-U2□□Z	78	54
ISMH1-20B30CB-U2□□Z	245	74
ISMH1-40B30CB-U2□1Z	245	74
ISMH1-75B30CB-U2□1Z	392	147
ISMH2-10C30C□-U2□□Y	686	196
ISMH2-15C30C□-U2□□Y	686	196
ISMH2-20C30CD-U2□1Y	686	196
ISMH2-25C30CD-U2□1Y	686	196
ISMH2-30C30CD-U2□1Y	980	392
ISMH2-40C30CD-U2□1Y	1176	392
ISMH2-50C30CD-U2□1Y	1176	392
ISMH3-85B15C□-U2□□Y	490	98
ISMH3-13C15C□-U2□□Y	686	343
ISMH3-18C15CD-U2□□Y	980	392
ISMH3-29C15CD-U2□□Z	1470	490
ISMH3-44C15CD-U2□□Z	1470	490
ISMH3-55C15CD-U2□□Z	1764	588
ISMH3-75C15CD-U2□□Z	1764	588
ISMH4-40B30CB-U2□□Z	245	74
ISMH4-75B30CB-U2□□Z	392	147

Electrical Specifications of Holding Brake

Motor Model	Holding Torque (Nm)	Supply Voltage (V) (±10%)	Rated Resistance (Ohm) (±7%)	Supply Current (A)	Braking Time (ms)	Pickup Time (ms)	
ISMH1-10B	0.32	24	96	0.23 to 0.27	10	30	
ISMH1-20B	1.3		82.3	0.25 to 0.34	20	50	
ISMH1-40B			50.1	0.40 to 0.57	25	60	
ISMH1-75B	2.39		8	25	0.81 to 1.14	30	90
ISMH2-10C							
ISMH2-15C							
ISMH2-20C							
ISMH2-25C							
ISMH2-30C							
ISMH2-30C	16		21.3	0.95 to 1.33	60	120	
ISMH2-40C							
ISMH2-50C	16		21.3	0.95 to 1.33	60	120	
ISMH3-85B							
ISMH3-13C							
ISMH3-18C							
ISMH3-29C	48	13.7	1.47 to 2.07	100	230		
ISMH3-44C							
ISMH3-55C							
ISMH3-75C							
ISMH4-40B	1.3	82.3	0.25 to 0.34	20	50		
ISMH4-75B	2.39	50.1	0.40 to 0.57	25	60		

Notes:

- The holding brake cannot be used for braking.
- The release time and action time of the holding brake vary with the discharge circuit. Take into consideration of the actual action time when using the brake.
- User needs to prepare 24 VDC power supply.

IS620P Series Servo Drive Overview

Designation Rules

IS620 P S 5R5 I

① ② ③ ④ ⑤

① Product series: IS620 servo drive	④ Rated output current: 1R6: 1.6A 2R8: 2.8A 5R5: 5.5A 7R6: 7.6A 8R4: 8.4A 012: 12A 017: 17A 021: 21A 026: 26A	⑤ Installation method: I: Substrate installation (standard)
② Product type: P: pulse type		
③ Voltage level: S: 220 V T: 380 V		

Servo Drive Specifications

Single-phase 220 V

SIZE	SIZE-A		
IS620P model	S1R6	S2R8	S5R5
Continuous output current (A)	1.6	2.8	5.5
Max. output current (A)	5.8	9.3	16.9
Power supply of main circuit	Single-phase 200-240 VAC, -15% to +10%, 50/60 Hz		
Power supply of control circuit	Single-phase 200-240 VAC, -15% to +10%, 50/60 Hz		
Braking treatment	External braking resistor	In-built	

Three-phase 220 V

SIZE-A	SIZE-C	
S5R5	S7R6	S012
5.5	7.6	11.6
16.9	17	28
Three-phase 200-240 VAC, -15% to +10%, 50/60 Hz		
Single-phase 200-240 VAC, -15% to +10%, 50/60 Hz		
In-built braking resistor		

Three-phase 380 V

SIZE	SIZE-C				SIZE-E		
IS620P model	T3R5	T5R4	T8R4	T012	T017	T021	T026
Continuous output current (A)	3.5	5.4	8.4	11.9	16.5	20.8	25.7
Max. output current (A)	8.5	14	20	28	42	55	65
Power supply of main circuit	Three-phase 380-440 VAC, -15% to +10%, 50/60 Hz						
Power supply of control circuit	Single-phase 380-440 VAC, -15% to +10%, 50/60 Hz						
Braking treatment	In-built braking resistor						

Note: Model SSR5 drive (220 V) can be connected to both single and three phase power supply. User can select either one based on actual power supply.

Mounting Dimensions of IS620P Servo Drive

SIZE	L (mm)	H (mm)	D (mm)	L1 (mm)	H1 (mm)	D1 (mm)	Screw Hole	Tightening Torque (Nm)
SIZE A	50	160	173	40	150	75	2-M4	0.6 to 1.2
SIZE C	90	160	183	80	150	75	2-M4	0.6 to 1.2
SIZE E	100	250	230	90	240	75	2-M4	0.6 to 1.2

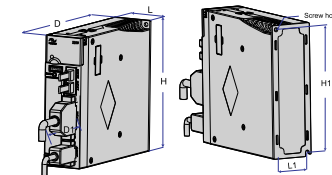

Performance Specifications

Item		Specifications	
Basic specifications	Control mode	220/380 V: single-phase or three-phase full wave rectification	
		IGBT PWM control, sine wave current drive	
	Feedback	Serial-type incremental: 20 bit	
	Usage conditions	Use/Storage temperature (note 1)	0 to +45°C (de-rated if ambient temperature exceeds 45°C)/-40 to +70 °C
		Use/Storage humidity	< 90% RH (no condensation)
		Anti-vibration/shock strength	4,9/19,6 m/s ²
IP level		Ip10	
Pollution level		Level 2	
Altitude	< 1000 m		
Performance	Rate of change (ROC) of speed (note 2)	ROC of load	0 to 100% load: < 0.5% (at rated rotational speed)
		ROC of voltage	Rated voltage ±10%: 0.5% (at rated rotational speed)
		ROC of temp.	25±25 °C: < 0.5% (at rated rotational speed)
	Speed control range	1:5000 (Lower limit: threshold value at which the motor still rotates with rated torque load.)	
	Frequency characteristic	1 kHz	
	Torque control precision (repeatability)	±2%	
	Soft start time setting	0 to 60s (acceleration and deceleration can be set separately)	
Speed/Torque control mode	Speed reference input	Reference voltage (note 3)	±10 VDC Common: 12 bit; Max.: 16 bit (16-bit AI terminal is a customized function)
			Input voltage: Max. ±12 V (forward rotation when reference is positive)
		Input impedance	Around 9 kΩ
	Torque reference input	Reference voltage	±10 VDC Common: 12 bit; Max.: 16 bit (16-bit AI terminal is a customized function)
			Input voltage: Max. ±12 V (forward rotation when reference is positive)
		Input impedance	Around 9 kΩ
		Circuit time constant	Around 47 μs
	Multi-speed reference	Speed selection	Use combination signals of DI1 (CMD1), DI2 (CMD2), DI7 (CMD3) and DI8 (CMD4) to realize selection of 0 to 15 speeds. (Other terminals can be used for this function.)
	Performance	Feed-forward compensation	0 to 100% (resolution set to 1%)
		Positioning completion width	0 to 65535 reference units (setting resolution: 1 reference unit)
		Input signals	Reference pulse
Input form	Differential drive Open-collector		
Input pulse frequency	Differential drive: Max. 4 Mpps Open-collector: Max. 200 Kpps		

Performance Specifications

Item		Specifications		
	Control signal	Clear signal (input form of this signal is the same as that of reference pulse)		
	In-built OC power supply (Note 4)	+24 V (in-built 2.4 kΩ)		
	Multi-position reference	Speed selection	Use combination signals of DI1 (CMD1), DI2 (CMD2), DI7 (CMD3) and DI8 (CMD4) to realize selection of 0 to 15 positions. (Other terminals can be used for this function.)	
I/O signals	Position output	Output form	Phase A, phase B, phase C: differential drive output	
		Frequency dividing ratio	Random frequency division	
	Digital input signals	(Signal allocation can be changed.)	DI x 9	Servo enabled, alarm reset, gain switchover, RUN command switchover, zero clamp function enabled, pulse input forbidden, forward drive forbidden, reverse drive forbidden, external forward torque limit, external reverse torque limit, forward JOG, reverse JOG, position step reference
			DO x 5	Servo drive ready, motor rotation output, zero speed signal, speed reached, position reached, positioning almost completed, torque limit, rotational speed limit, brake output, alarm output, fault output, 3-digit fault code output
	Digital output signals	(Signal allocation can be changed.)		
In-built functions	Overshoot prevention	Deceleration stops when P-OT and N-OT functions work.		
	Electronic gear ratio	0.1 ≤ B/A ≤ 419430.4		
	Protection	Over-current, over-voltage, under-voltage, overload, main circuit detection abnormality, heatsink overheat, power phase loss, over-speed, encoder abnormality, CPU abnormality, parameter abnormality, etc		
	LED display	Main power CHARGE: 5-digit LED display		
	Analog monitoring function	In-built analog terminal for monitoring of speed/torque reference signals		
Communication functions	Device connection	RS232, RS485, CAN communication		
		COMM protocol	Modbus, CANlink, CANopen (CANlink & CANopen are customized functions)	
	1:N COMM	When communication is RS485, N max = 247		
	Shaft add. setting	Set based on user parameters.		
Others	Function	Status display, user parameter setting, monitoring display, alarm tracking display, JOG operation and auto-tuning, mapping of speed/torque reference signals		
		Gain adjustment, alarm record, JOG operation		

Notes

Note 1: Install the servo drive within this temperature range. If the servo drive is to be placed in an electrical cabinet, temperature inside the cabinet shall not exceed this range.
 Note 2: ROC of speed is defined as below:

$$\text{ROC of speed} = \frac{\text{Speed at empty load} - \text{Speed at full load}}{\text{Rated speed}} \times 100\%$$

Actually, voltage and temperature changes will cause deviation to the amplifier, which leads to change of resistance. This change will be manifested by change of speed. This change of speed is manifested by a ratio of the rated speed, which contains changes caused by both changes of voltage and temperature.

Note 3: Forward rotation indicates that the motor rotates clockwise, viewing from the reverse load side.
 Note 4: In-built OC power supply is not electrically isolated from the control circuit of the servo drive.

IS620P Servo Drive Overview

Connection between IS620P Servo Drive and Peripheral Devices

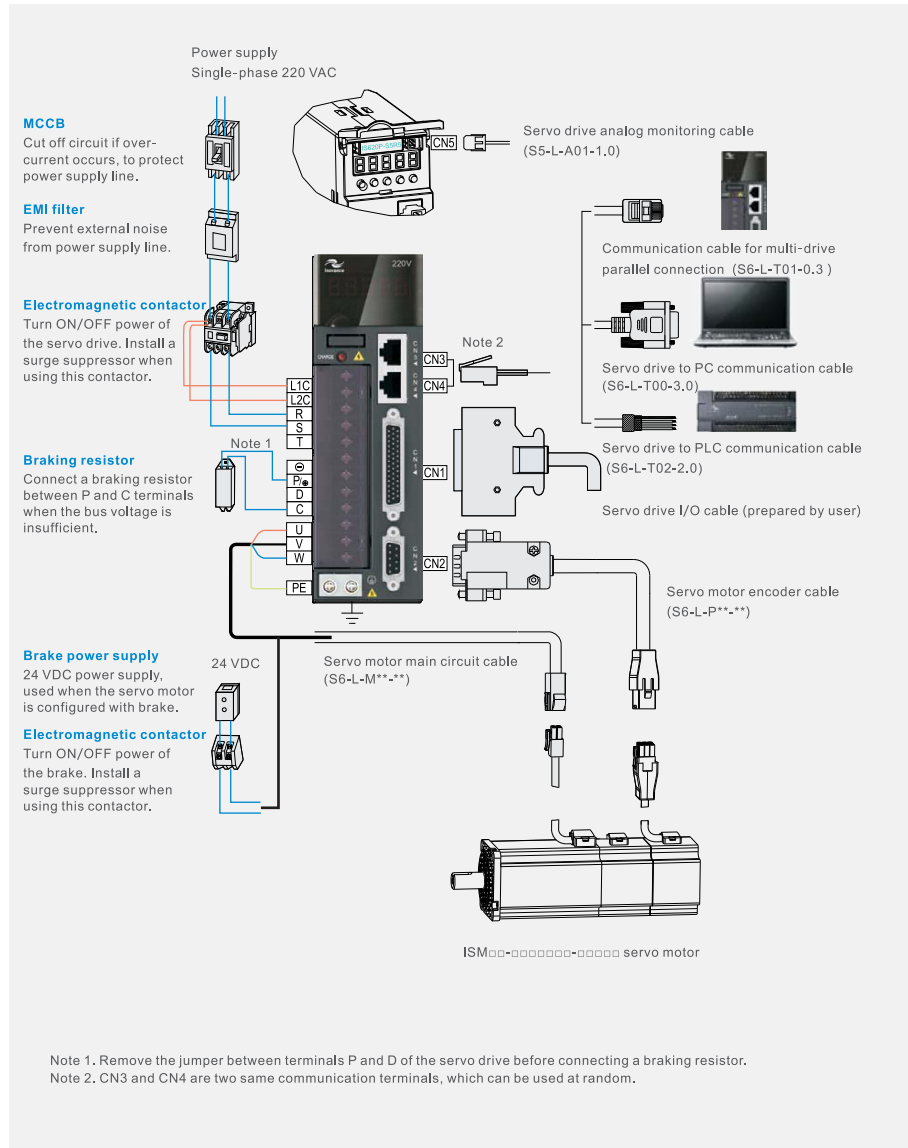

IS620P Servo Drive Terminal Pin Layout

Main Circuit Terminal Description

Terminal Symbol	Terminal Name	Terminal Function	
R, S, T	Main circuit power input terminals	IS620P: S1R6, S2R8, S5R5	Main circuit single-phase 220 VAC power input. Only R and S terminals are used.
		IS620PS: 5R5, S7R6, S012	Main circuit three-phase 220 V power input.
		IS620P: T3R5, T5R4, T8R4 T012, T017, T021, T026	Main circuit three-phase 380 V power input.
L1C, L2C	Control power input terminals	Control circuit power input: Refer to the rated voltage on the product nameplate.	
P/⊙, D, C	External braking resistor terminals	IS620P: S1R6, S2R8	Connect an external braking resistor between P/⊙ and C terminals if the braking capacity is insufficient. You need to purchase the braking resistor separately.
		IS620P: S5R5, S7R6, S012, T3R5, T5R4, T8R4, T012, T017, T021, T026	P/⊙ and D are shorted by default. Remove the jumper between P/⊙ and C and connect an external braking resistor between P/⊙ and C if the braking capacity is insufficient. You need to purchase the braking resistor separately.
P/⊙, ⊙	Common DC bus terminal	Used for DC bus connection when multiple servo drives are connected in parallel.	
U, V, W	Servo motor connection terminals	Connect to the U, V and W terminals of the servo motor.	
PE	Grounding terminal	Two grounding terminals are respectively connected to the power supply grounding terminal and the servo motor grounding terminal. The entire system must be grounded.	

Control Signal Terminal Description

CN1: control signal terminal

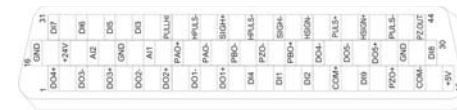

Signal	Function	Pin No.	Function Description
DI1	P-OT	9	Forward drive forbiden
DI2	N-OT	10	Reverse drive forbiden
DI3	INHIBIT	34	Pulse input forbiden
DI4	ALM-RST	8	Alarm reset (edge valid)
DI5	S-ON	33	Servo enabled
DI6	ZCLAMP	32	Zero clamp function
DI7	GAIN-SEL	31	Gain switchover
DI8	Home Switch	30	Home switch
DI9	(Reserved)	12	
Common	+24V	17	Internal 24 V power supply; Range: 20 to 28 V; Max. output current: 200 mA
	COM-	14	
	COM+	11	Power supply input (12 to 24 V)
DO1+	S-RDY+	7	ON when the servo drive is ready and S-ON signal can be received.
DO1-	S-RDY-	6	
DO2+	COIN+	5	Position reached
DO2-	COIN-	4	
DO3+	ZERO+	3	Zero speed
DO3-	ZERO-	2	
DO4+	ALM+	1	ON when a fault occurs.
DO4-	ALM-	26	
DO5+	Home Attain+	28	ON when home return is completed.
DO5-	Home Attain-	27	

Function	Pin No.	Function Description	
Position reference	PULS+	41	Reference pulse input mode: 1. Direction + pulse 2. Phase A + B quadrature pulse 3. CW/CCW pulse
	PULS-	43	
	SIGN+	37	
	SIGN-	39	
	HPULS+	38	High-speed reference pulse input
	HPULS-	36	
HSIGN+	42	High-speed position reference	
HSIGN-	40		
PULLHI	35	External power input terminal of reference pulse	
GND	29	Ground	

Function	Pin No.	Function Description	
Analog	AI2	18	Common analog input signals: Resolution: 12 bit; Input voltage: Max. ±12 V
	AI1	20	
	GND	19	Analog input signal ground

Cable Specifications

Physical Appearance of Cables for Servo Motor and Servo Drive

Cable Name	Cable Model	Cable Length (mm)	Cable Appearance
Servo motor main circuit cable	S6-L-M00-3.0	3000	
	S6-L-M00-5.0	5000	
	S6-L-M00-10.0	10000	
	S6-L-M11-3.0	3000	
	S6-L-M11-5.0	5000	
	S6-L-M11-10.0	10000	
	S6-L-M12-3.0	3000	
	S6-L-M12-5.0	5000	
	S6-L-M12-10.0	10000	
	S6-L-M22-3.0	3000	
S6-L-M22-5.0	5000		
S6-L-M22-10.0	10000		
Servo motor encoder cable	S6-L-P00-3.0	3000	
	S6-L-P00-5.0	5000	
	S6-L-P00-10.0	10000	
	S6-L-P01-3.0	3000	
S6-L-P01-5.0	5000		
S6-L-P01-10.0	10000		
Servo drive to PC communication cable	S6-L-T00-3.0	3000	
Communication cable for multi-drive parallel connection	S6-L-T01-0.3	300	
Servo drive to PLC communication cable	S6-L-T02-2.0	2000	
Resistor plug for servo drive communication terminal	S6-L-T03-0.0	0	

Physical Appearance of Analog Output Cable

Cable Name	Cable Model	Cable Length (mm)	Cable Appearance
Servo drive analog output cable with loose wire at one end	S5-L-A01-1.0	1000	

Cable Connectors

Connectors of Power Cables on Servo Motor Side

6-PIN connector

Black 6-pin connector:
Plastic housing: MOLEX-50361736;
Terminal: MOLEX-39000061

Pin No.	Signal
1	U
2	V
4	W
5	PE
3	Brake (regardless of positive or negative)
6	Brake (regardless of positive or negative)

10SL-4P aviation plug

(MIL-DTL-5015 series 3108E10SL-4P) aviation plug

Pin No.	Signal
A	Brake (regardless of positive or negative)
B	

CN1 cable connector

DB44 PIN connector

Black 44-pin connector:
Plastic housing: DB25P (TELE-DATA COM)
Core: HDB44P (TELE-DATA COM)

Pin No.	Signal	Pin No.	Signal
9	DI1	7	DO1+
10	DI2	6	DO1-
34	DI3	5	DO2+
8	DI4	4	DO2-
33	DI5	3	DO3+
32	DI6	2	DO3-
31	DI7	1	DO4+
30	DI8	26	DO4-
12	DI9	28	DO5+
17	+24V	27	DO5-
11	COM+	25	PBO+
13	PZO+	29	GND
14	COM-	35	PULLHI
15	+5	36	HPULS-
16	GND	37	SIGH+
18	AI2	38	HPULS+
19	GND	39	SIGH-
20	AI1	40	HSIGN-
21	PAO+	41	PULS+
22	PAO-	42	HSIGN+
23	PBO-	43	PULS-
24	PZO-	44	PZ-OUT

20-18 aviation plug

(MIL-DTL-5015 series 3108E20-18S) aviation plug

New Structure		Old Structure	
Pin No.	Signal	Pin No.	Signal
B	U	B	U
I	V	I	V
F	W	F	W
G	PE	G	PE
C	Brake (regardless of positive or negative)		
E			

20-22 aviation plug

(MIL-DTL-5015 series 3108E20-22S) aviation plug

Y Series		Z Series	
Pin No.	Signal	Pin No.	Signal
A	U	A	U
C	V	C	V
E	W	E	W
F	PE	F	PE
		B	Brake (regardless of positive or negative)
		D	

Cable Connectors

Connectors of encoder cables at servo motor side

9-PIN connector

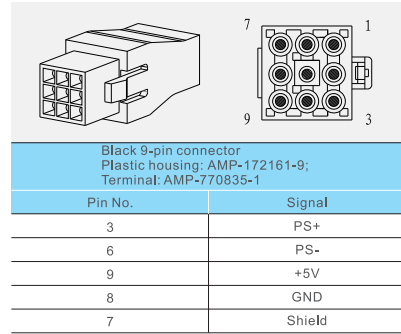

20-29 aviation plug

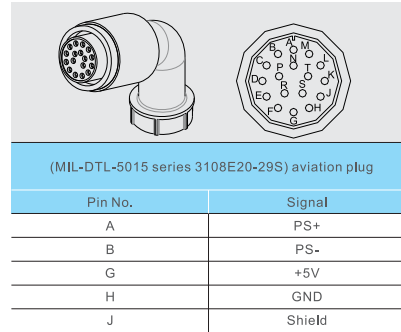

Connectors of encoder cables at servo drive side

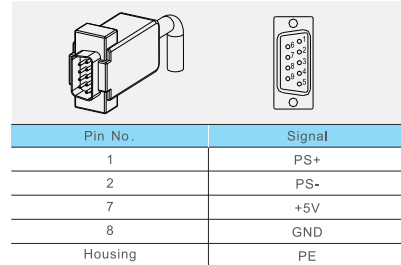

Precautions on cable selection

To determine the length of the encoder cable, consider voltage drop caused by the cableresistance and signal attenuation caused by the capacitors. It is recommended to use twisted-pair cable of size AWG26 or above (as per UL2464 standard) and with a length within 10 m. The following table lists the recommended cable sizes.

Cable Size	Cross Area	Ω/km	Allowed Cable Length
AWG 26	0.1282	143	10.0
AWG 25	0.1520	79.6	16.0
AWG 24	0.2051	89.4	18.0
AWG 23	0.2588	68.5	20.9
AWG 22	0.3247	54.3	26.4

Communication cable for multi-drive parallel connection

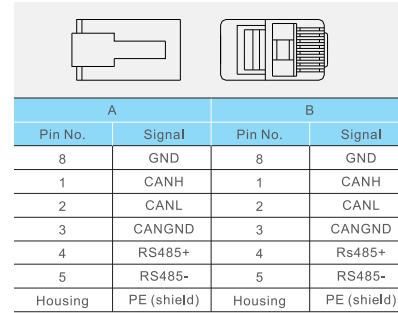

Servo drive to PC communication cable

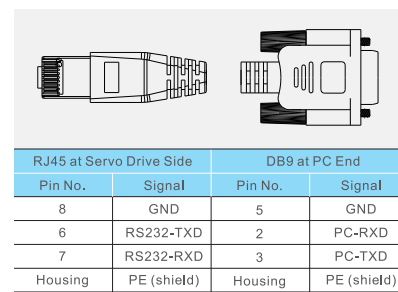

Servo drive to PLC communication cable

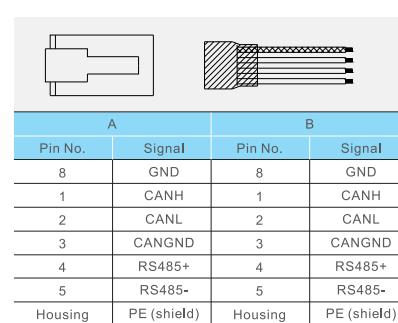

Wiring

The IS620P servo drive supports three control modes: speed control, position control and torque control. The following figure shows the standard wiring of these three control modes.

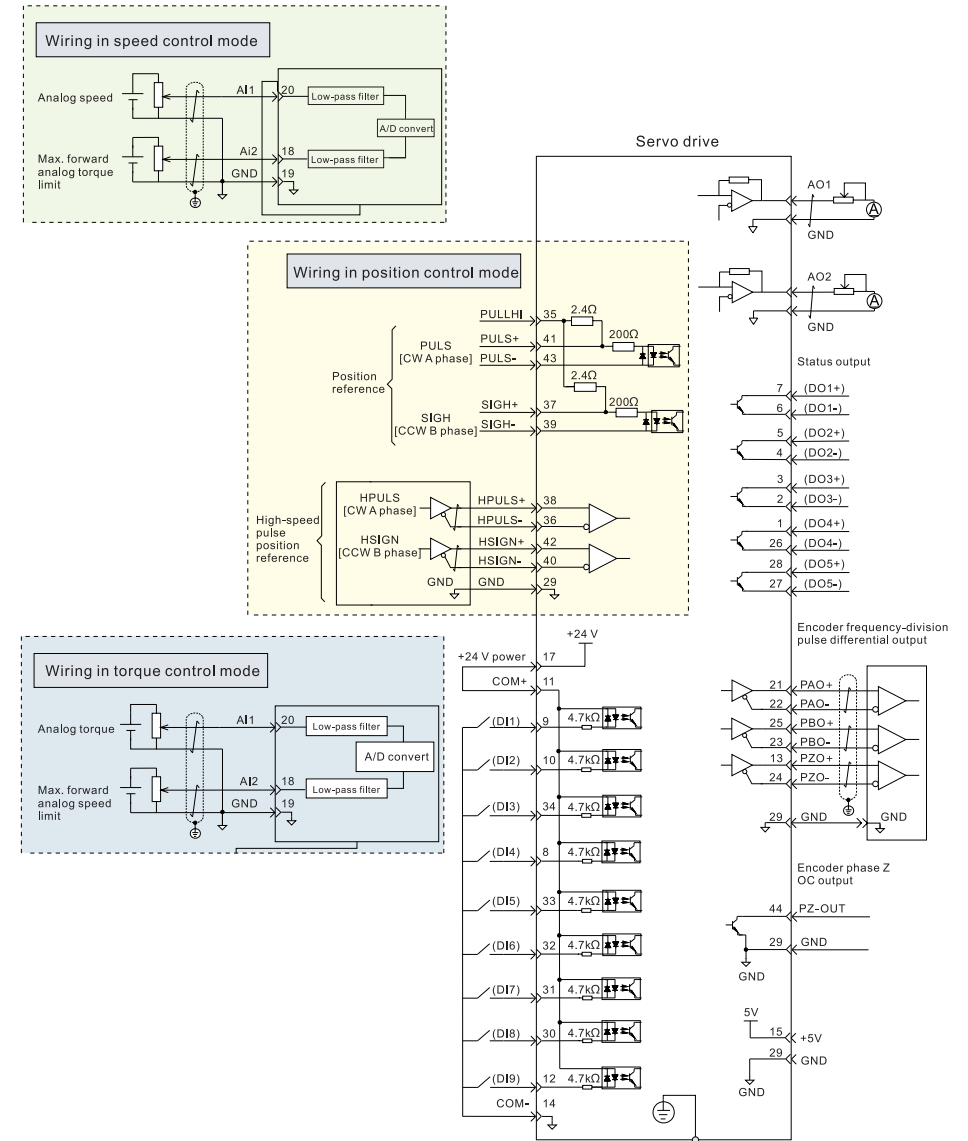

Servo Drive and Servo Motor Configuration

220 V

Rated Speed (rpm)	Max. Speed (rpm)	Capacity (W)	Servo Motor Model (ISM□□-□□□□□□-*****)	Motor Frame Size	Servo Drive Model (IS620P□□□□□)		Servo Drive Size	Servo Drive SN (H01-02)	
					Single-phase 220 VAC	3-phase 220 VAC			
3000	5000	100	H1 (low inertia, small capacity)	10B30CB	40	S1R6	A	00002	
		200		20B30CB	60	S1R6	A	00002	
	400	40B30CB		60	S2R8	A	00003		
	750	75B30CB		80	S5R5		A	00005	
	6000	1000	H2 (low inertia, medium capacity)	10C30CB	100		S7R6	C	00006
1500		15C30CB		100		S012	C	00007	
1500	3000	850	H3 (medium inertia, medium capacity)	85B15CB	130		S7R6	C	00006
		1300		13C15CB	130		S012	C	00007
3000	6000	400	H4 (medium inertia, small capacity)	40B30CB	60	S2R8	A	00003	
		750		75B30CB	60	S5R5		A	00005

380 V

Rated Speed (rpm)	Max. Speed (rpm)	Capacity (W)	Servo Motor Model (ISM□□-□□□□□□-*****)	Motor Frame Size	Servo Drive Model (IS620P□□□□□)		Servo Drive Size	Servo Drive SN (H01-02)
					3-phase 380 VAC			
3000	6000	1000	H2 (low inertia, medium capacity)	10C30CD	100	T5R4	C	10002
		1500		15C30CD	100	T5R4	C	10002
		2000		20C30CD (※)	100	T8R4	C	10003
		2500		25C30CD (※)	100	T8R4	C	10003
		3000		30C30CD (※)	130	T012	C	10004
		4000		40C30CD (※)	130	T017	E	10005
	5000	50C30CD (※)		130	T017	E	10005	
1500	3000	850	H3 (low inertia, medium capacity)	85B15CD	130	T3R5	C	10001
		1300		13C15CD	130	T5R4	C	10002
		1800		18C15CD	130	T8R4	C	10003
		2900		29C15CD	180	T012	C	10004
		4400		44C15CD (※)	180	T017	E	10005
		5500		55C15CD (※)	180	T021	E	10006
	7500	75C15CD (※)	180	T026	E	10007		

Note: Models marked with "※" are in development.

Adapted Cables

Servo Motor	Servo Motor Main Circuit Cable			Servo Motor Encoder Cable			Connector Kit		
	L = 3.0 m	L = 5.0 m	L = 10.0 m	L = 3.0 m	L = 5.0 m	L = 10.0 m	Standard Motor	Motor with Brake	
ISMH1 ISMH4	S6-L-M00-3.0	S6-L-M00-5.0	S6-L-M00-10.0	S6-L-P00-3.0	S6-L-P00-5.0	S6-L-P00-10.0	S6-C1	CN1 terminal	-
								CN2 terminal	
								6-pin connector	
								9-pin connector	
ISMH2	S6-L-M11-3.0	S6-L-M11-5.0	S6-L-M11-10.0	S6-L-P01-3.0	S6-L-P01-5.0	S6-L-P01-10.0	S6-C2 (elbow)	CN1 terminal	-
								CN2 terminal	
								20-18 aviation plug (elbow)	
								20-29 aviation plug (elbow)	
ISMH3 (1.8 kW and below)	S6-L-M11-3.0	S6-L-M11-5.0	S6-L-M11-10.0	S6-L-P01-3.0	S6-L-P01-5.0	S6-L-P01-10.0	S6-C2 (elbow)	CN1 terminal	S5-C11 (with 10SL-4P aviation plug)
								CN2 terminal	
								20-18 aviation plug (elbow)	
								20-29 aviation plug (elbow)	
ISMH3 (2.9 kW)	S6-L-M12-3.0	S6-L-M12-5.0	S6-L-M12-10.0	S6-L-P01-3.0	S6-L-P01-5.0	S6-L-P01-10.0	S6-C3 (elbow)	CN1 terminal	-
								CN2 terminal	
ISMH3 (2.9 kW and above)	S6-L-M22-3.0	S6-L-M22-5.0	S6-L-M22-10.0	S6-L-P01-3.0	S6-L-P01-5.0	S6-L-P01-10.0	S6-C3 (elbow)	20-22 aviation plug (elbow)	-
								20-29 aviation plug (elbow)	

Note: Servo motor encoder cable includes CN1 plug.

Braking Resistor Specifications

Servo Drive Model	In-built Braking Resistor		Allowed Min. Resistance (Ω)	Max. Braking Energy Absorbed by Capacitor (J)	
	Resistance (Ω)	Capacity (W)			
Single-phase 220 V	IS620PS1R6I	-	-	50	5
	IS620PS2R8I	-	-	45	12
Single/3-phase 220 V	IS620PS5R5I	50	40	40	16
Three-phase 220 V	IS620PS7R6I	25	80	20	22
	IS620PS012I				15
Three-phase 380 V	IS620PT3R5I	100	80	80	3
	IS620PT5R4I	100	80	60	5
	IS620PT8R4I	50	80	45	8
	IS620PT012I				11
	IS620PT017I				15
	IS620PT021I	50	100	45	19
	IS620PT026I				23