



IS 300

Series Servo Drive
User Manual

Shenzhen Inovance Technology Co.,Ltd.

efesotomasyon.com

V1.0

Data code:19010120

Preface

The IS300 series servo drive is specially designed for the permanent magnet synchronous motor (PMSM). It provides wide coverage of capacity (rated current 2.1–725 A, rated power 400 W–400 kW).

In addition to standard servo drive functions, IS300 can also implement the control of pumps. It is a cost effective servo drive in the middle to high power range of the existing market.

This manual is a guideline for the selection, installation, parameter setting, on-site commissioning and troubleshooting of the IS300 servo drive.

Before using the servo drive, please read this manual carefully so that you fully comprehend the features of the product. Please ensure that the manual is kept safely before forwarding to the end user.

Upon Unpacking, Please Ensure That:

1. The nameplate model and ratings of the servo drive match your order. The box contains the product, the certificate of conformity, the manual and warranty.
2. The product is not damaged. If you find any omission or damage, please contact Inovance or our agent immediately.

First-time Use

The person who uses this product for the first time must read the manual carefully. If they have any doubt concerning some functions or performance, please contact our technical support personnel for advice, thereby ensuring the correct use of our product.

With our commitment to constant improvement of the servo drive, our company may change the information without further notice.



The IS300 series servo drive complies with the following international standards:

- IEC/EN 61800-5-1: 2003, Adjustable speed electrical power drive systems - Safety requirements
- IEC/EN 61800-3: 2004, Adjustable speed electrical power drive systems – Part 3: EMC requirements and specific test methods

Some products have passed the CE certification.

Contents

Preface	1
Chapter 1 Product Information	6
1.1 IS300 Servo Drive Designation Rules	6
1.2 IS300 Models and Technical Data	6
1.3 Selection of IS300 Brake Parts	9
1.4 Selection of IS300 Peripheral Electrical Parts	12
1.5 Physical Dimensions and Mounting Dimensions	15
Chapter 2 Wiring	24
2.1 Wiring Method	24
2.2 Description of Main Circuit Terminals	24
2.3 Description of Control Circuit Terminals	24
2.4 Description of Jumpers of IS300	26
2.5 Description of Terminals of PG Card of IS300	27
2.6 Wiring of External Braking Unit	27
Chapter 3 Commissioning Procedure	30
3.1 Servo Pump Commissioning Flow Chart	30
3.2 Motor Trial RUN	30
3.3 Servo Pump Application Trail Run	31
Chapter 4 Operation and Display	36
4.1 Operation Panel	36
4.2 How to Query and Modify Function Codes	38
4.3 QUICK Operation	39
4.4 Querying Status Parameters	40
4.5 Password Setting	41
4.6 Motor Tuning	41
Chapter 5 Troubleshooting	44
5.1 Faults and Solutions	44
5.2 Common Faults and Solutions	55
Chapter 6 ISMG Servo Motor (Voltage Class: 400V)	58
6.1 ISMG Servo Motor Designation Rules	58

6.2 ISMG Servo Motor Specification Parameters	59
6.3 ISMG Servo Motor Appearance and Mounting Dimensions	63
6.4 Description of Supporting Board of ISMG Servo Motor Base	66
6.5 Wiring of ISMG Servo Motor	67
Appendix	70
Appendix 1 Function Code Table	70
Appendix 2 Servo Motor Code Table	94
Appendix 3 Configuration Examples of Servo Pump System	95





Product Information

Chapter 1 Product Information

1.1 IS300 Servo Drive Designation Rules

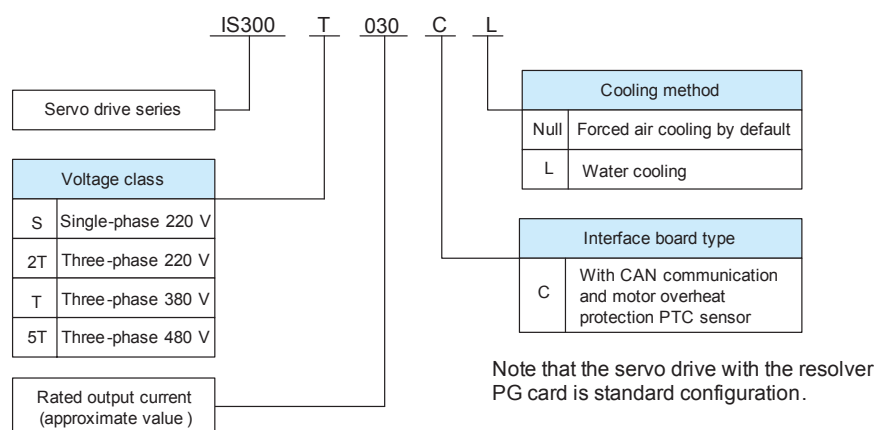

1.2 IS300 Models and Technical Data

Model	Power Capacity (kVA)	Input Current (A)	Output Current (A)	Adapted Motor (S1)	
				kW	HP
Single-phase 220 V, 50/60 Hz					
IS300S002-C	1	5.4	2.3	0.4	0.5
IS300S003-C	1.5	8.2	4	0.75	1
IS300S004-C	3	14	7	1.5	2
IS300S005-C	4	23	9.6	2.2	3
Three-phase 220 V, 50/60 Hz					
IS300-2T002-C	1.5	3.4	2.1	0.4	0.5
IS300-2T003-C	3	5	3.8	0.75	1
IS300-2T004-C	4	5.8	5.1	1.5	2
IS300-2T005-C	5.9	10.5	9	2.2	3
IS300-2T010-C	8.9	14.6	13	3.7	5
IS300-2T020-C	17	26	25	5.5	7.5
IS300-2T030-C	21	35	32	7.5	10
IS300-2T040-C	30	46.5	45	11	15

Model	Power Capacity (kVA)	Input Current (A)	Output Current (A)	Adapted Motor (S1)	
				kW	HP
IS300-2T050-C	40	62	60	15	20
IS300-2T070-C	57	76	75	18.5	25
IS300-2T080-C	69	92	91	22	30
IS300-2T100-C	85	113	112	30	40
IS300-2T140-C	114	157	150	37	50
IS300-2T170-C	134	180	176	45	60
IS300-2T210-C	160	214	210	55	75
IS300-2T300-C	231	307	304	75	100
IS300-2T140-C-L	114	157	150	37	50
IS300-2T170-C-L	134	180	176	45	60
IS300-2T210-C-L	160	214	210	55	75
IS300-2T300-C-L	231	307	304	75	100
Three-phase 380 V, 50/60 Hz					
IS300T002-C	1.5	3.4	2.1	0.75	1
IS300T003-C	3	5	3.8	1.5	2
IS300T004-C	4	5.8	5.1	2.2	3
IS300T005-C	5.9	10.5	9	3.7	5
IS300T010-C	8.9	14.6	13	5.5	7.5
IS300T015-C	11	20.5	17	7.5	10
IS300T020-C	17	26	25	11	15
IS300T030-C	21	35	32	15	20
IS300T035-C	24	38.5	37	18.5	25
IS300T040-C	30	46.5	45	22	30
IS300T050-C	40	62	60	30	40
IS300T070-C	57	76	75	37	50
IS300T080-C	69	92	91	45	60
IS300T100-C	85	113	112	55	75
IS300T140-C	114	157	150	75	100
IS300T170-C	134	180	176	90	125
IS300T210-C	160	214	210	110	150
IS300T250-C	192	256	253	132	200
IS300T300-C	231	307	304	160	250
IS300T370-C	250	385	377	200	300

Model	Power Capacity (kVA)	Input Current (A)	Output Current (A)	Adapted Motor (S1)	
				kW	HP
IS300T420-C	280	430	426	220	300
IS300T460-C	355	468	465	250	400
IS300T520-C	396	525	520	280	370
IS300T580-C	445	590	585	315	500
IS300T650-C	500	665	650	355	420
IS300T720-C	565	785	725	400	530
IS300T140-C-L	114	157	150	75	100
IS300T170-C-L	134	180	176	90	125
IS300T210-C-L	160	214	210	110	150
IS300T250-C-L	192	256	253	132	200
IS300T300-C-L	231	307	304	160	250
Three-phase 480 V, 50/60 Hz					
IS300-5T002-C	1.5	3.4	2.1	0.75	1
IS300-5T003-C	3	5	3.8	1.5	2
IS300-5T004-C	4	5.8	5.1	2.2	3
IS300-5T005-C	5.9	10.5	9	3.7	5
IS300-5T010-C	8.9	14.6	13	5.5	7.5
IS300-5T015-C	11	20.5	17	7.5	10
IS300-5T020-C	17	26	25	11	15
IS300-5T030-C	21	35	32	15	20
IS300-5T035-C	24	38.5	37	18.5	25
IS300-5T040-C	30	46.5	45	22	30
IS300-5T050-C	40	62	60	30	40
IS300-5T070-C	57	76	75	37	50
IS300-5T080-C	69	92	91	45	60
IS300-5T100-C	85	113	112	55	70
IS300-5T140-C	114	157	150	75	100
IS300-5T170-C	134	180	176	90	125
IS300-5T210-C	160	214	210	110	150
IS300-5T250-C	192	256	253	132	175
IS300-5T300-C	231	307	304	160	210
IS300-5T370-C	250	385	377	200	260
IS300-5T420-C	280	430	426	220	300

Model	Power Capacity (kVA)	Input Current (A)	Output Current (A)	Adapted Motor (S1)	
				kW	HP
IS300-5T460-C	355	468	465	250	350
IS300-5T520-C	396	525	520	280	370
IS300-5T580-C	445	590	585	315	420
IS300-5T650-C	500	665	650	355	470
IS300-5T720-C	565	785	725	400	530
IS300-5T140-C-L	114	157	150	75	100
IS300-5T170-C-L	134	180	176	90	125
IS300-5T210-C-L	160	214	210	110	150
IS300-5T250-C-L	192	256	253	132	175
IS300-5T300-C-L	231	307	304	160	210

Note

The models in grey are customized servo drives (water cooling).

1.3 Selection of IS300 Brake Parts

Model	(Braking Resistor) Recommended Power	(Braking Resistor) Recommended Resistance	Braking Unit	Remark
Single-phase 220 V				
IS300S002-C	80 W	$\geq 200 \Omega$	Built-in	No special description
IS300S003-C	80 W	$\geq 150 \Omega$		
IS300S004-C	100 W	$\geq 100 \Omega$		
IS300S005-C	100 W	$\geq 70 \Omega$		
Three-phase 220 V				
IS300-2T002-C	150 W	$\geq 150 \Omega$	Built-in	No special description
IS300-2T003-C	150 W	$\geq 110 \Omega$		
IS300-2T004-C	250 W	$\geq 100 \Omega$		
IS300-2T005-C	300 W	$\geq 65 \Omega$		
IS300-2T010-C	400 W	$\geq 45 \Omega$		
IS300-2T020-C	800 W	$\geq 22 \Omega$		
IS300-2T030-C	1000 W	$\geq 16 \Omega$		
IS300-2T040-C	1500 W	$\geq 11 \Omega$		
IS300-2T050-C	2500 W	$\geq 8 \Omega$		
IS300-2T070-C	3.7 kW	$\geq 4 \Omega$	External	MDBU-70-A

Model	(Braking Resistor) Recommended Power	(Braking Resistor) Recommended Resistance	Braking Unit	Remark
IS300-2T080-C	4.5 kW	≥4 Ω	External	MDBU-70-A
IS300-2T100-C	5.5 kW	≥4 Ω	External	MDBU-70-A
IS300-2T140-C	7.5 kW	≥4 Ω	External	MDBU-70-A
IS300-2T170-C	4.5 kW x2	≥4 Ω x2	External	MDBU-70-A x2
IS300-2T210-C	5.5 kW x2	≥4 Ω x2	External	MDBU-70-A x2
IS300-2T300-C	16 kW	≥1.2 Ω	External	MDBU-200-A
IS300-2T140-C-L	7.5 kW	≥4 Ω	External	MDBU-70-A
IS300-2T170-C-L	4.5 kW x2	≥4 Ω x2	External	MDBU-70-A x2
IS300-2T210-C-L	5.5 kW x2	≥4 Ω x2	External	MDBU-70-A x2
IS300-2T300-C-L	16 kW	≥1.2 Ω	External	MDBU-200-A
Three-phase 380 V				
IS300T002-C	150 W	≥300 Ω	Built-in	No special description
IS300T003-C	150 W	≥220 Ω		
IS300T004-C	250 W	≥200 Ω		
IS300T005-C	300 W	≥130 Ω		
IS300T010-C	400 W	≥90 Ω		
IS300T015-C	500 W	≥65 Ω		
IS300T020-C	800 W	≥43 Ω		
IS300T030-C	1000 W	≥32 Ω		
IS300T035-C	1300 W	≥25 Ω		
IS300T040-C	1500 W	≥22 Ω		
IS300T050-C	2500 W	≥16 Ω		
IS300T070-C	3.7 kW	≥8 Ω	External	MDBU-70-B
IS300T080-C	4.5 kW	≥8 Ω	External	MDBU-70-B
IS300T100-C	5.5 kW	≥8 Ω	External	MDBU-70-B
IS300T140-C	7.5 kW	≥8 Ω	External	MDBU-70-B
IS300T170-C	4.5 kW x2	≥8 Ω x2	External	MDBU-70-B x2
IS300T210-C	5.5 kW x2	≥8 Ω x2	External	MDBU-70-B x2
IS300T250-C	6.5 kW x2	≥8 Ω x2	External	MDBU-70-B x2
IS300T300-C	16 kW	≥2.5 Ω	External	MDBU-200-B
IS300T370-C	20 kW	≥2.5 Ω	External	MDBU-200-B
IS300T420-C	22 kW	≥2.5 Ω	External	MDBU-200-B
IS300T460-C	12.5 kW x2	≥2.5 Ω x2	External	MDBU-200-B x2
IS300T520-C	14 kW x2	≥2.5 Ω x2	External	MDBU-200-B x2
IS300T580-C	16 kW x2	≥2.5 Ω x2	External	MDBU-200-B x2
IS300T650-C	17 kW x2	≥2.5 Ω x2	External	MDBU-200-B x2

Model	(Braking Resistor) Recommended Power	(Braking Resistor) Recommended Resistance	Braking Unit	Remark
IS300T720-C	14 kW x3	$\geq 2.5 \Omega$ x3	External	MDBU-200-B x3
IS300T140-C-L	7.5 kW	$\geq 8 \Omega$	External	MDBU-70-B
IS300T170-C-L	4.5 kW x2	$\geq 8 \Omega$ x2	External	MDBU-70-B x2
IS300T210-C-L	5.5 kW x2	$\geq 8 \Omega$ x2	External	MDBU-70-B x2
IS300T250-C-L	6.5 kW x2	$\geq 8 \Omega$ x2	External	MDBU-70-B x2
IS300T300-C-L	16 kW	$\geq 2.5 \Omega$	External	MDBU-200-B
Three-phase 480 V				
IS300-5T002-C	150 W	$\geq 300 \Omega$	Built-in	No special description
IS300-5T003-C	150 W	$\geq 220 \Omega$		
IS300-5T004-C	250 W	$\geq 200 \Omega$		
IS300-5T005-C	300 W	$\geq 130 \Omega$		
IS300-5T010-C	400 W	$\geq 90 \Omega$		
IS300-5T015-C	500 W	$\geq 65 \Omega$		
IS300-5T020-C	800 W	$\geq 43 \Omega$		
IS300-5T030-C	1000 W	$\geq 32 \Omega$		
IS300-5T035-C	1300 W	$\geq 25 \Omega$		
IS300-5T040-C	1500 W	$\geq 22 \Omega$		
IS300-5T050-C	2500 W	$\geq 16 \Omega$		
IS300-5T070-C	3.7 kW	$\geq 16.0 \Omega$	External	MDBU-70-D
IS300-5T080-C	4.5 kW	$\geq 16 \Omega$	External	MDBU-70-D
IS300-5T100-C	5.5 kW	$\geq 8 \Omega$	External	MDBU-70-D
IS300-5T140-C	7.5 kW	$\geq 8 \Omega$	External	MDBU-70-D
IS300-5T170-C	4.5 kW x2	$\geq 8 \Omega$ x2	External	MDBU-70-D x2
IS300-5T210-C	5.5 kW x2	$\geq 8 \Omega$ x2	External	MDBU-70-D x2
IS300-5T250-C	6.5 kW x2	$\geq 8 \Omega$ x2	External	MDBU-70-D x2
IS300-5T300-C	16 kW	$\geq 2.5 \Omega$	External	MDBU-200-D
IS300-5T370-C	20 kW	$\geq 2.5 \Omega$	External	MDBU-200-D
IS300-5T420-C	22 kW	$\geq 2.5 \Omega$	External	MDBU-200-D
IS300-5T460-C	12.5 kW x2	$\geq 2.5 \Omega$ x2	External	MDBU-200-D x2
IS300-5T520-C	14 kW x2	$\geq 2.5 \Omega$ x2	External	MDBU-200-D x2
IS300-5T580-C	16 kW x2	$\geq 2.5 \Omega$ x2	External	MDBU-200-D x2
IS300-5T650-C	17 kW x2	$\geq 2.5 \Omega$ x2	External	MDBU-200-D x2
IS300-5T720-C	14 kW x3	$\geq 2.5 \Omega$ x3	External	MDBU-200-D x3
IS300-5T140-C-L	7.5 kW	$\geq 8 \Omega$	External	MDBU-70-D
IS300-5T170-C-L	4.5 kW x2	$\geq 8 \Omega$ x2	External	MDBU-70-D x2
IS300-5T210-C-L	5.5 kW x2	$\geq 8 \Omega$ x2	External	MDBU-70-D x2

Model	(Braking Resistor) Recommended Power	(Braking Resistor) Recommended Resistance	Braking Unit	Remark
IS300-5T250-C-L	6.5 kW x2	$\geq 8 \Omega$ x2	External	MDBU-70-D x2
IS300-5T300-C-L	16 kW	$\geq 2.5 \Omega$	External	MDBU-200-D

Note

- "x2" indicates that two braking units with respective braking resistor are connected in parallel. "x3" has the same indication.
- The models in grey are customized servo drives (water cooling).

1.4 Selection of IS300 Peripheral Electrical Parts

Model	MCCB (A)	Recommended Contactor (A)	Recommended Main Circuit Cable at Input Side (mm ²)	Recommended Main Circuit Cable at Output Side (mm ²)	Recommended Control Circuit Cable (mm ²)
Single-phase 220 V					
IS300S002-C	16	10	2.5	2.5	1.0
IS300S003-C	16	10	2.5	2.5	1.0
IS300S004-C	20	16	4.0	2.5	1.0
IS300S005-C	32	20	6.0	4.0	1.0
Three-phase 220 V					
IS300-2T002-C	10	10	2.5	2.5	1.0
IS300-2T003-C	16	10	2.5	2.5	1.0
IS300-2T004-C	16	10	2.5	2.5	1.0
IS300-2T005-C	25	16	4.0	4.0	1.0
IS300-2T010-C	32	25	4.0	4.0	1.0
IS300-2T020-C	63	40	4.0	4.0	1.0
IS300-2T030-C	63	40	6.0	6.0	1.0
IS300-2T040-C	100	63	10	10	1.5
IS300-2T050-C	125	100	16	10	1.5
IS300-2T070-C	160	100	16	16	1.5
IS300-2T080-C	200	125	25	25	1.5
IS300-2T100-C	200	125	35	25	1.5
IS300-2T140-C	250	160	50	35	1.5
IS300-2T170-C	250	160	70	35	1.5
IS300-2T210-C	350	350	120	120	1.5
IS300-2T300-C	500	400	185	185	1.5
IS300-2T140-C-L	250	160	50	35	1.5
IS300-2T170-C-L	250	160	70	35	1.5

Model	MCCB (A)	Recommended Contactor (A)	Recommended Main Circuit Cable at Input Side (mm ²)	Recommended Main Circuit Cable at Output Side (mm ²)	Recommended Control Circuit Cable (mm ²)
IS300-2T210-C-L	350	350	120	120	1.5
IS300-2T300-C-L	500	400	185	185	1.5
Three-phase 380 V					
IS300T002-C	10	10	2.5	2.5	1.0
IS300T003-C	16	10	2.5	2.5	1.0
IS300T004-C	16	10	2.5	2.5	1.0
IS300T005-C	25	16	4.0	4.0	1.0
IS300T010-C	32	25	4.0	4.0	1.0
IS300T015-C	40	32	4.0	4.0	1.0
IS300T020-C	63	40	4.0	4.0	1.0
IS300T030-C	63	40	6.0	6.0	1.0
IS300T035-C	100	63	6	6	1.5
IS300T040-C	100	63	10	10	1.5
IS300T050-C	125	100	16	10	1.5
IS300T070-C	160	100	16	16	1.5
IS300T080-C	200	125	25	25	1.5
IS300T100-C	200	125	35	25	1.5
IS300T140-C	250	160	50	35	1.5
IS300T170-C	250	160	70	35	1.5
IS300T210-C	350	350	120	120	1.5
IS300T250-C	400	400	150	150	1.5
IS300T300-C	500	400	185	185	1.5
IS300T370-C	600	600	150 x2	150 x2	1.5
IS300T420-C	600	600	150 x2	150 x2	1.5
IS300T460-C	800	600	185 x2	185 x2	1.5
IS300T520-C	800	800	185 x2	185 x2	1.5
IS300T580-C	800	800	150 x3	150 x3	1.5
IS300T650-C	800	800	150 x4	150 x4	1.5
IS300T720-C	1000	1000	150 x4	150 x4	1.5
IS300T140-C-L	250	160	50	35	1.5
IS300T170-C-L	250	160	70	35	1.5
IS300T210-C-L	350	350	120	120	1.5
IS300T250-C-L	400	400	150	150	1.5
IS300T300-C-L	500	400	185	185	1.5
Three-phase 480 V					
IS300-5T002-C	10	10	2.5	2.5	1.0

Model	MCCB (A)	Recommended Contactor (A)	Recommended Main Circuit Cable at Input Side (mm ²)	Recommended Main Circuit Cable at Output Side (mm ²)	Recommended Control Circuit Cable (mm ²)
IS300-5T003-C	16	10	2.5	2.5	1.0
IS300-5T004-C	16	10	2.5	2.5	1.0
IS300-5T005-C	25	16	4.0	4.0	1.0
IS300-5T010-C	32	25	4.0	4.0	1.0
IS300-5T015-C	40	32	4.0	4.0	1.0
IS300-5T020-C	63	40	4.0	4.0	1.0
IS300-5T030-C	63	40	6.0	6.0	1.0
IS300-5T035-C	100	63	6	6	1.5
IS300-5T040-C	100	63	10	10	1.5
IS300-5T050-C	125	100	16	10	1.5
IS300-5T070-C	160	100	16	16	1.5
IS300-5T080-C	200	125	25	25	1.5
IS300-5T100-C	200	125	35	25	1.5
IS300-5T140-C	250	160	50	35	1.5
IS300-5T170-C	250	160	70	35	1.5
IS300-5T210-C	350	350	120	120	1.5
IS300-5T250-C	400	400	150	150	1.5
IS300-5T300-C	500	400	185	185	1.5
IS300-5T370-C	600	600	150 x2	150 x2	1.5
IS300-5T420-C	600	600	150 x2	150 x2	1.5
IS300-5T460-C	800	600	185 x2	185 x2	1.5
IS300-5T520-C	800	800	185 x2	185 x2	1.5
IS300-5T580-C	800	800	150 x3	150 x3	1.5
IS300-5T650-C	800	800	150 x4	150 x4	1.5
IS300-5T720-C	1000	1000	150 x4	150 x4	1.5
IS300-5T140-C-L	250	160	50	35	1.5
IS300-5T170-C-L	250	160	70	35	1.5
IS300-5T210-C-L	350	350	120	120	1.5
IS300-5T250-C-L	400	400	150	150	1.5
IS300-5T300-C-L	500	400	185	185	1.5

Note

The models in grey are customized servo drives (water cooling).

1.5 Physical Dimensions and Mounting Dimensions

1.5.1 IS300 (Forced Air Cooling)

■ IS300(*)002-C-IS300(*)030-C Physical Dimensions & Mounting Dimensions

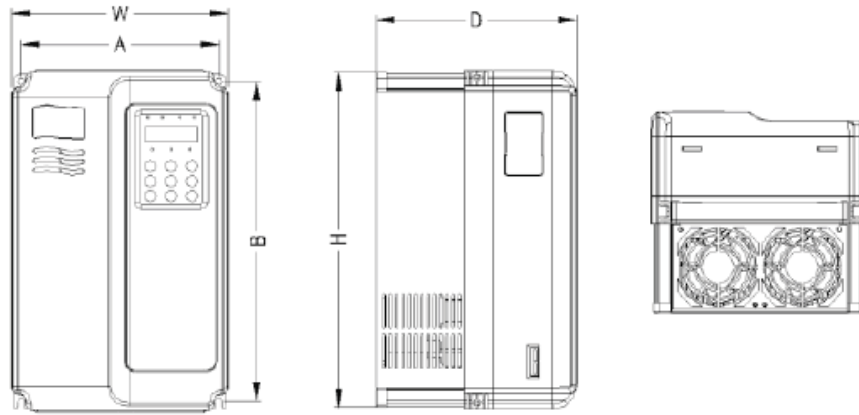

■ IS300(*)035-C-IS300(*)720-C Physical Dimensions & Mounting Dimensions

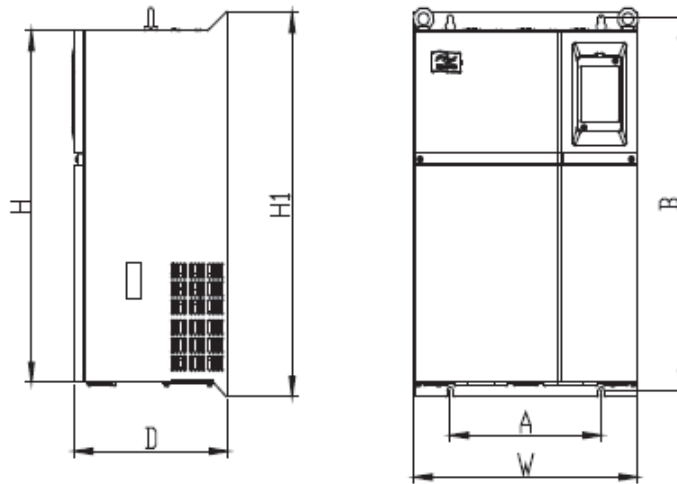

■ Table of IS300 Physical Dimensions and Mounting Dimensions

Model	Mounting Hole (mm)		Physical Dimensions (mm)				Mounting Hole Diameter (mm)	Weight (kg)
	A	B	H	H1	W	D		
Single-phase 220 V								
IS300S002-C	113	172	186	/	125	164	Ø5.0	1.1
IS300S003-C								
IS300S004-C								
IS300S005-C								
Three-phase 220 V								
IS300-2T002-C	113	172	186	/	125	164	Ø5.0	1.1
IS300-2T003-C								
IS300-2T004-C								
IS300-2T005-C	148	236	248	/	160	183	Ø5.0	2.5
IS300-2T010-C								
IS300-2T020-C	190	305	322	/	208	192	Ø6	6.5
IS300-2T030-C								
IS300-2T040-C	235	447	432	463	285	228	Ø6.5	20
IS300-2T050-C								
IS300-2T070-C	260	580	549	600	385	265	Ø10	32
IS300-2T080-C								
IS300-2T100-C								
IS300-2T140-C	343	678	660	700	473	307	Ø10	47
IS300-2T170-C								
IS300-2T210-C	449	903	880	930	579	380	Ø10	90
IS300-2T300-C								
Three-phase 380 V								
IS300T002-C	113	172	186	/	125	164	Ø5.0	1.1
IS300T003-C								
IS300T004-C								
IS300T005-C	148	236	248	/	160	183	Ø5.0	2.5
IS300T010-C								
IS300T015-C	190	305	322	/	208	192	Ø6	6.5
IS300T020-C								
IS300T030-C								

Model	Mounting Hole (mm)		Physical Dimensions (mm)				Mounting Hole Diameter (mm)	Weight (kg)
	A	B	H	H1	W	D		
IS300T035-C	235	447	432	463	285	228	Ø6.5	20
IS300T040-C								
IS300T050-C								
IS300T070-C	260	580	549	600	385	265	Ø10	32
IS300T080-C								
IS300T100-C								
IS300T140-C	343	678	660	700	473	307	Ø10	47
IS300T170-C								
IS300T210-C	449	903	880	930	579	380	Ø10	90
IS300T250-C								
IS300T300-C								
IS300T370-C	420	1030	983	1060	650	377	Ø12	130
IS300T420-C								
IS300T460-C								
IS300T520-C								
IS300T580-C	520	1300	1203	1358	800	400	Ø16	200
IS300T650-C								
IS300T720-C								
Three-phase 480 V								
IS300-5T002-C	113	172	186	/	125	164	Ø5.0	1.1
IS300-5T003-C								
IS300-5T004-C								
IS300-5T005-C	148	236	248	/	160	183	Ø5.0	2.5
IS300-5T010-C								
IS300-5T015-C	190	305	322	/	208	192	Ø6	6.5
IS300-5T020-C								
IS300-5T030-C								
IS300-5T035-C	235	447	432	463	285	228	Ø6.5	20
IS300-5T040-C								
IS300-5T050-C								
IS300-5T070-C	260	580	549	600	385	265	Ø10	32
IS300-5T080-C								
IS300-5T100-C								

Model	Mounting Hole (mm)		Physical Dimensions (mm)				Mounting Hole Diameter (mm)	Weight (kg)
	A	B	H	H1	W	D		
IS300-5T140-C	343	678	660	700	473	307	Ø10	47
IS300-5T170-C								
IS300-5T210-C	449	903	880	930	579	380	Ø10	90
IS300-5T250-C								
IS300-5T300-C								
IS300-5T370-C	420	1030	983	1060	650	377	Ø12	130
IS300-5T420-C								
IS300-5T460-C								
IS300-5T520-C								
IS300-5T580-C	520	1300	1203	1358	800	400	Ø16	200
IS300-5T650-C								
IS300-5T720-C								

1.5.2 IS300 (Water Cooling)

■ Physical Dimensions & Mounting Dimensions of IS300(*)140-C-L and IS300(*)170-C-L

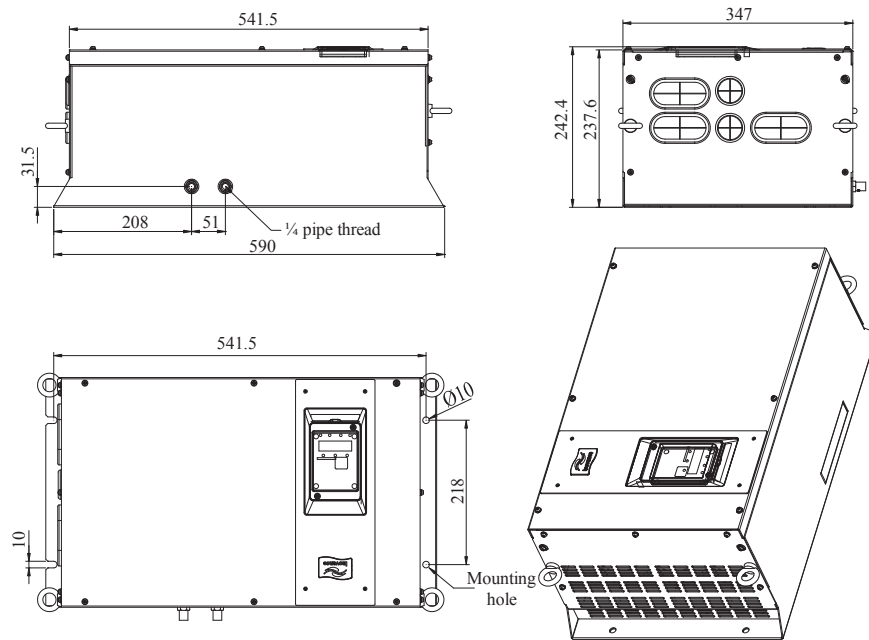

■ Physical Dimensions & Mounting Dimensions of IS300T210(*)-C-L, IS300T250(*)-C-L and IS300T300(*)-C-L

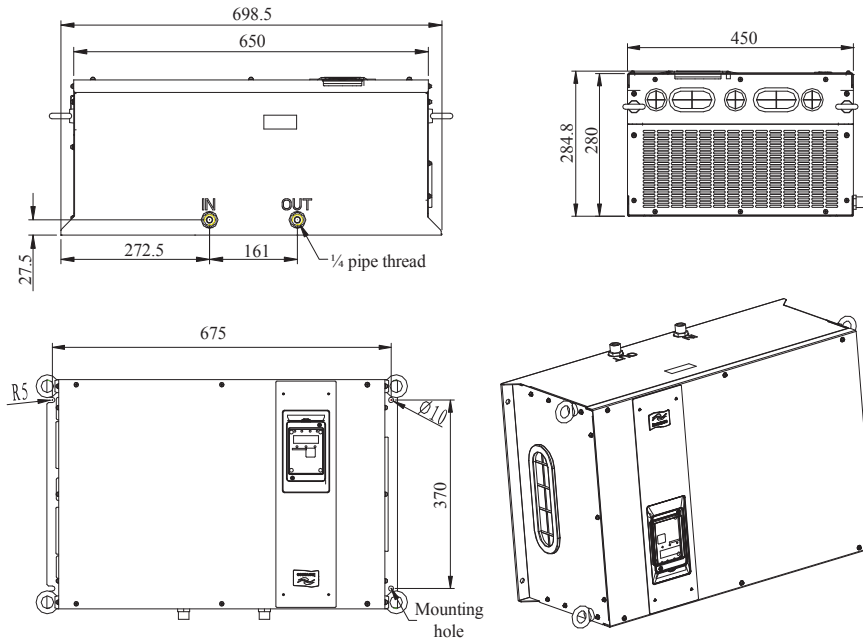

1.5.3 Mounting Hole Dimensions of Operation Panel

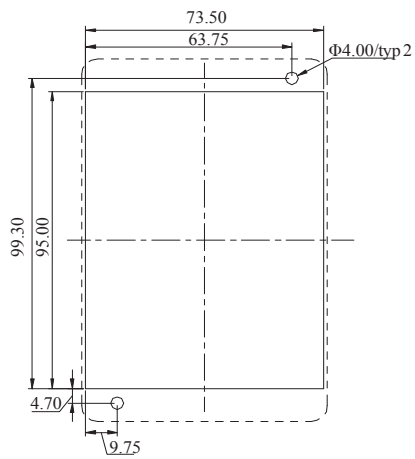

1.5.4 Dimensions of External DC Reactor

The IS300 servo drives below IS300 (*)140-C-* have built-in DC reactor.

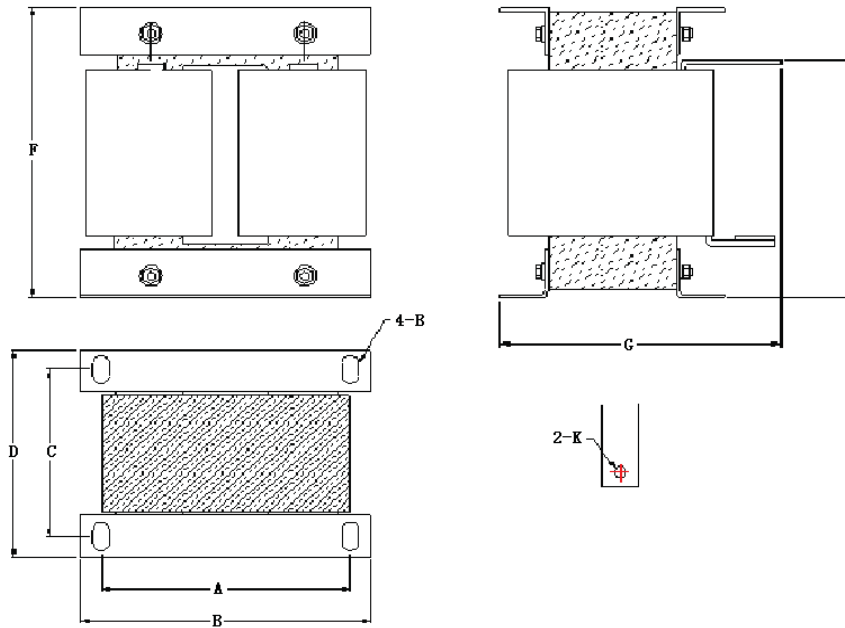

■ Adapted DC Reactor and Mounting Dimension

Adapted Servo Drive Model	A	B	C	D	E	F	G	Mounting Hole	Copper Medal Connecting Hole Diameter	Reactor Model
IS300-2T140-C, IS300-2T170-C	160	190	125	161	192	255	195	10*15	Ø12	DCL-0200
IS300T140-C, IS300T170-C										
IS300-5T140-C, IS300-5T170-C										
IS300-2T210-C	160	190	125	161	192	255	195	10*15	Ø12	DCL-0250
IS300T210-C										
IS300-5T210-C										

Adapted Servo Drive Model	A	B	C	D	E	F	G	Mounting Hole	Copper Medal Connecting Hole Diameter	Reactor Model
IS300-2T300-C	160	190	125	161	192	255	195	10*15	Ø12	DCL-0360
IS300T250-C, IS300T300-C										
IS300-5T250-C, IS300-5T300-C										
IS300T370-C, IS300T420-C	190	230	93	128	250	325	200	13*18	Ø15	DCL-0600
IS300-5T370-C, IS300-5T420-C										
IS300T460-C, IS300T520-C	190	230	93	128	250	325	200	13*18	Ø15	DCL-0700
IS300-5T460-C, IS300-5T520-C										
IS300T580-C, IS300T650-C, IS300T720-C	224	250	135	165	260	330	235	12*20	Ø14	DCL-1000
IS300-5T580-C, IS300-5T650-C, IS300-5T720-C										

■ How to Install External DC Reactor

The IS300 servo drives of IS300(*)140-C-* and above are configured with external DC reactor as standard. The DC reactor is packed in separate wooden box for delivery.

When installing the DC reactor, please remove the short circuit cooper bar between the main circuit connection terminal P and (+). Then connect the DC reactor between terminals P and (+) with no polarity requirement. The copper bar will not be used any longer once the installation is complete.

1.5.5 Dimensions of External Braking Unit

The IS300 servo drives below IS300(*)070-C-*have internal braking unit.

■ Physical Dimensions and Mounting Dimensions of MDBU-70-X

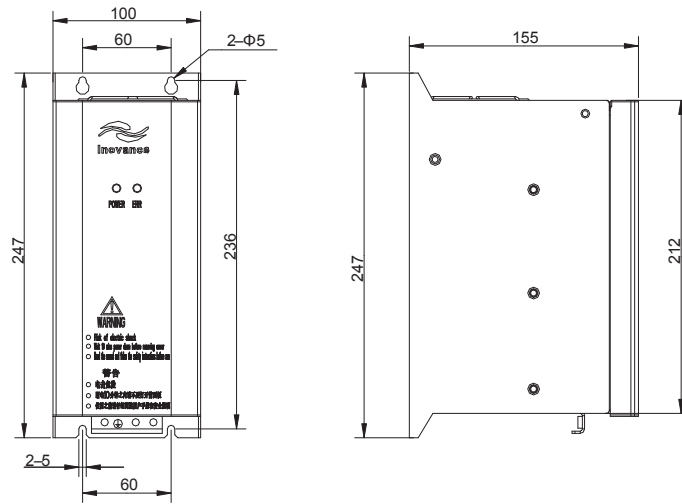

■ Physical Dimensions and Mounting Dimensions of MDBU-200-X

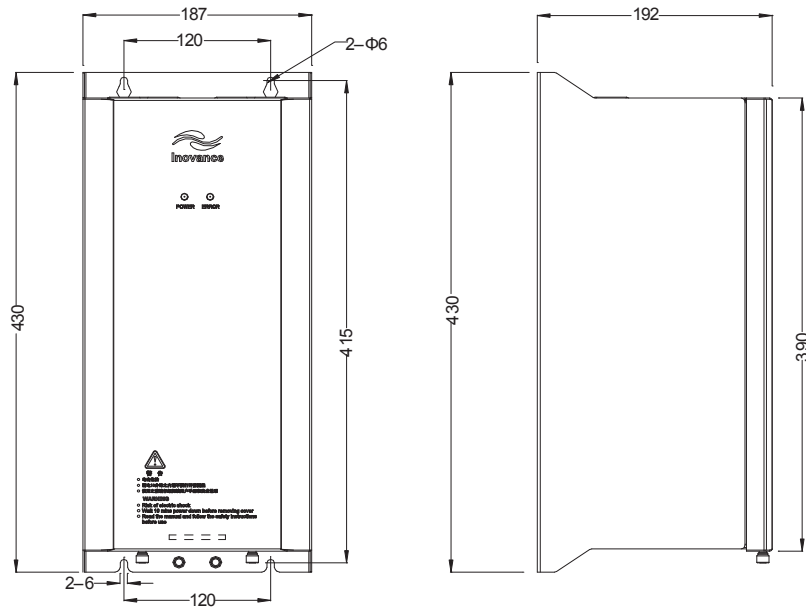



Wiring

Chapter 2 Wiring

2.1 Wiring Method

For the wiring method of the IS300, see the inserted figure at the end of this chapter.

2.2 Description of Main Circuit Terminals

















Terminals	Name	Description
R, S, T	Single-phase power supply input terminals	Connecting points of the three-phase AC power supply
(+), (-)	Positive and negative terminals of DC bus	Input points of common DC bus Connecting points of the external braking unit of IS300(*)070-C-* and above.
(+), PB	Connecting terminals of braking resistor	Connecting points of the braking resistor of IS300(*)050-C and below
P, (+)	Connecting terminals of braking resistor	Connecting points of the external reactor of IS300(*)140-C-* and above
U, V, W	Servo drive output terminals	Connecting to the three-phase motor
	Grounding terminal	Grounding

2.3 Description of Control Circuit Terminals

Type	Terminal	Name	Description
Power Supply	+10 V-GND	+10 V power supply	Provide $10 \pm 10\%$ V power to external unit. Generally, it provides power supply to external potentiometer with resistance range of 1-5 k Ω . Maximum output current: 10 mA
	+13 V-GND	Pressure sensor power supply	Provide $13 \pm 10\%$ V power to external unit. Generally, it provides power supply to pressure sensor. Maximum output current: 10 mA
	+24 V-COM	+24 V power supply	Provide +24 V power supply to external unit. Generally, it provides power supply to DI/DO terminals. 24 $\pm 10\%$ V, no-load empty voltage not exceeding 30 V Maximum output current: 200 mA It is isolated from GND internally.
	OP	External power supply input terminal	It is isolated from COM and 24 V internally. It is connected to +24 V via jumper by delivery. When applying external signal to drive DI1-DI5, OP needs to be connected to external power supply and be disconnected from +24 V (decided by J7 jumper).
Analog input	AI1-GND	Analog input 1 (Pressure setting by default)	Input range: ± 10 V, 12-bit resolution, correction accuracy 0.5% Resistance input: 100 k Ω
	AI2-GND	Analog input 2 (Flow setting by default)	Input range: ± 10 V, 12-bit resolution, correction accuracy 0.5% Resistance input: 100 k Ω
	AI3-GND	Analog input 3 (pressure sensor signal input by default)	Input range: ± 10 V or 0–20 mA determined by J5 jumper, 12-bit resolution, correction accuracy 0.5% Resistance input: 100 k Ω (voltage input), 500 Ω (current input)
Digital Input	DI1-DI5-COM	Digital input 1	Isolation drain-to-source input programming terminal, input frequency <100 Hz Resistance input: 3.3 k Ω Voltage range for level input: 9–30 V
	PTCP-PTCN	Motor overheat protection input	Motor overheat protection PTC sensor Supporting PTC130, PTC150, etc.
Communication	CANH/ CANL/ CGND	CAN COM terminal	Maximum COM speed: 1 Mbps Whether to connect to terminal resistor is determined by J8 jumper
	485B/485A	485 COM terminal	Reserved, isolated This function is not available by default Maximum COM speed: 230 Kbps Whether to connect to terminal resistor is determined by J9 jumper

Type	Terminal	Name	Description
Analog output	AO1-GND	Analog output 1	Voltage or current output is decided by J4 jumper. Output voltage range: 0–10 V/0–20 mA 12-bit resolution, correction accuracy 1%, maximum-load resistance value $\leq 500 \Omega$
	AO2-GND	Analog output 2	Voltage or current output is decided by J6 jumper. Output voltage range: 0–10 V/0–20 mA 12-bit resolution, correction accuracy 1%, maximum-load resistance value $\leq 500 \Omega$
Relay output	T/A1-T/B1	NC terminal	Contact driving capacity: 250 Vac, 3 A, $\text{COS } \phi = 0.4$; 30 Vdc, 1 A
	T/A1-T/A 3-T/C1-T/C3	NO terminal	
Auxiliary interface	CNR1	Operation panel interface	Connecting to operation panel or copy unit

2.4 Description of Jumpers of IS300

Jumper	Jumper Position	Description	Jumper Position	Description
J2		GND terminal connecting to earth capacitance (adopted when the servo drive is well tied to ground.)		GND terminal not connecting to earth capacitance (adopted when the servo drive is poorly tied to ground.)
J3		COM terminal connecting to earth capacitance (adopted when the servo drive is well tied to ground.)		COM terminal not connecting to earth capacitance (adopted when the servo drive is poorly tied to ground.)
J4		AO1 output voltage (0–10 VDC)		AO1 output current (0–20 mA)
J5		AI3 input voltage (-10–10 VDC)		AI3 input current (0–20 mA)
J6		AO2 output voltage (0–10 VDC)		AO2 output current (0–20 mA)
J7		Internal power driving DI1–DI5		External power driving DI1–DI5
J8		CAN COM connecting to terminal resistor (adopted by terminal for multi-drive communication)		CAN COM not connecting to terminal resistor (adopted by middle machine for multi-drive communication)
J9		485 COM connecting to terminal resistor (adopted by terminal for multi-drive communication)		485 COM not connecting to terminal resistor (adopted by middle machine for multi-drive communication)

Note

Jumper position indicates the position that could be seen when you face the terminal.

2.5 Description of Terminals of PG Card of IS300

SN	Name	Description
1	EXC	Excitation signal
2	/EXC	
3	SIN	SIN feedback signal
4	SINLO	
5	COS	COS feedback signal
9	COSLO	
6	--	--
7		
8		

■ Definition of IS300 Supporting Signal Lines (for Reference)

Definition	EXC-	EXC+	SIN+	SIN-	COS+	COS-
Supporting encoder cable color	Red	Blue	White	Brown	Yellow	Green
Corresponding IS300 PG card pin	1	2	3	4	5	9

2.6 Wiring of External Braking Unit

2.6.1 Wiring of One External Braking Unit

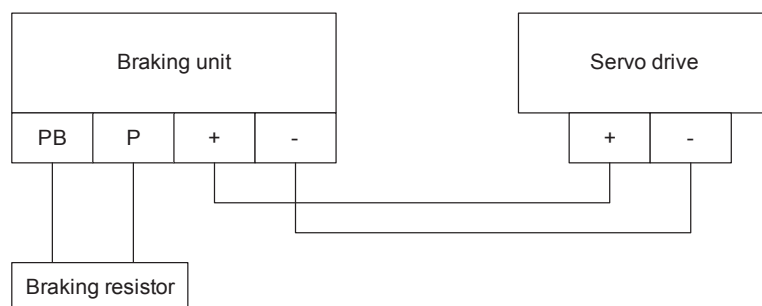

2.6.2 Wiring of Multiple External Braking Units in Parallel

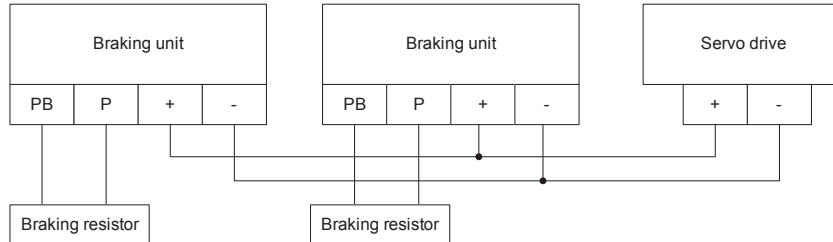
**Note**

- The braking resistors can only be connected to their respective braking unit. Parallel connection at the output side of the braking units is prohibited. Otherwise, damage to the braking units may result.
- Use twisted cable to connect the servo drive and the braking unit. The cable shall be no longer than 3 m.



Commissioning Procedure

Chapter 3 Commissioning Procedure

3.1 Servo Pump Commissioning Flow Chart

Note

- For details on commissioning, refer to the following contents.
 - The injection molding machine can also be started without the * steps.
-
-

3.2 Motor Trial RUN

To perform motor trial RUN, do as follows:

1. Set motor parameters in group F1 (F1-00 to F1-05, F1-15).
2. Set the number of pole-pairs of the resolver.
3. Set the servo drive to non-oil pressure control mode (A3-00=0).
4. Set the servo drive to operation panel control mode (F0-02=0). In this case, the LOCAL/ REMOT indicator on the panel is off.
5. Perform motor tuning (automatic identification) (F1-16).

Note

Motor tuning must be performed in the condition that the servo drive is in the operation panel control mode (F0-02=0).

- F1-16=0: No operation

It doesn't conduct the motor parameters tuning.

- F1-16=1: Static tuning

Adopt when the motor's counter EMF is known. Run the motor at the low speed without opening the overflow valve during tuning.

- F1-16=2: Dynamic tuning

Adopt it when the motor's counter EMF is unknown. Run the motor at the high speed with opening the overflow valve during tuning. With-load tuning will affect the motor tuning accuracy and the system control result.

If you can set F1 (F1-00 to F1-05, F1-15) and A1-04 (the number of pole-pairs of the resolver) correctly, just set F1-16 to 1 (static tuning).

If you can only set F1 (F1-00 to F1-05) and A1-04 is unknown to determine F1-15 (counter EMF), you must set F1-16 to 1 (dynamic tuning).

The value of F1-16 will restore to 0 automatically after tuning is complete.

If the servo drive reports Err43 during tuning, it indicates that the encoder feedback signal is wrong. Please check the encoder signal wiring and installation accuracy.

6. For trial RUN, set running frequency (F0-08) and run the motor using the operation panel. Meanwhile, detect whether the output current is normal and whether the motor is running stably.
 - Determine that the running direction of the drive is correct. If it is incorrect, reverse any two phases of UVW, re-perform motor tuning and then trial run the motor.
 - If there is abnormal running, please check the motor parameters in F1 and the setting of A1-04 setup. Then re-perform the motor tuning and trial run the motor.
 - If the motor vibrates or runs with a low frequency noise, please decrease the speed loop (F2-00, F2-01, F2-03, F2-04) and current loop (F2-13, F2-14, F2-15, F2-16) appropriately.
 - If the motor rotational speed is not steady, please increase the speed loop (F2-00, F2-01, F2-03, F2-04) and the current loop (F2-13, F2-14, F2-15, F2-16) appropriately.

Note

Slow response of the speed loop and current loop will affect the pressure stability directly. If allowed, please increase the speed loop and current loop values.

3.3 Servo Pump Application Trail Run

3.3.1 AI Null Drift Auto Correction (A3-20)

Make sure that the drive runs at zero speed before AI null drift auto-correction.

Set AI null drift auto correction (A3-20) to 1, the drive will perform an AI null drift auto correction.

Write the detected null drift values of the three analog channels into F4-18 (AI1 min. input), F4-23 (AI2 minimum. input) and F4-28 (AI3 min. input). You can query the detected values in U1-07, U1-08, and U1-09.

3.3.2 Oil Pressure Control Mode Selection (A3-00)

1. A3-00=0: Non-Oil pressure control mode
2. A3-00=1: Drive oil pressure control mode 1.

Oil pressure command and flow command is given via CAN communication, AI3 provides oil pressure feedback command, and the drive conducts oil pressure control.

3. A3-00=2: Drive oil pressure control mode 2.

AI1 provides oil pressure command, AI2 provides flow command, AI3 provides oil pressure feedback command, and the drive conducts oil pressure control.

4. A3-00=3: Oil pressure control mode (special use)
The servo pump control parameters in group A3 are invalid.
5. A3-00=4: Reserved.

3.3.3 Automatic Setting of Parameters in Oil Pressure Control

When the non-oil pressure mode switches to the oil pressure mode (A3-00≠"0"), the related parameters will be set automatically set. See the following table for details.

Function Code	Name	Setting
F0-01	Control mode	1: Vector control (VC)
F0-02	Command source selection	1: Terminal input (LED indicator on)
F0-03	Main frequency source X selection	If A3-00=2, set F0-03 to 3 (AI2). If A3-00=1 or 3, set F0-03=9 (via communication).
F0-07	Frequency source selection	0: Main frequency source X
F0-17	Acceleration time 1	0.0s
F0-18	Deceleration time 1	0.0s
F1-00	Motor type selection	2: PMSM
F4-00	DI1 function selection	1: Forward RUN (FWD, pump enabled)
F4-01	DI2 function selection	48: Servo pump PID selection terminal 1
F4-02	DI3 function selection	49: Servo pump PID selection terminal 2
F4-03	DI4 function selection	9: Fault reset (RESET)
F4-04	DI5 function selection	50: CAN COM enabled
F5-01	Control board relay (T/A1-T/B1-T/C1) output selection	2: Fault output
F5-02	Control board relay (T/A2-T/C2) output selection	23: Double-discharge plunger pump sloping switchover (NO)
F5-03	Control board relay (T/A3-T/C3) output selection	24: Output NC in pressure control

These parameters are retentive at power failure in the oil pressure control mode. They will restore to the automatically set value once the servo drive is re-powered on. Once the system is switched over from oil pressure control to non-oil pressure control, the parameters will restore to the value that was set before system switch-over to the oil pressure control.

3.3.4 Setting of flow and Oil Pressure Commands

- A3-01: Max. rotational speed
Set the maximum motor rotational speed, which corresponds to the 100% flow command.
- A3-02: System oil pressure.
Set the system maximum pressure.
- A3-03: Max. oil pressure.
Set the pressure span of the pressure transducer (corresponding to the output pressure

transducer of 0–10 VDC.

3.3.5 Setting of Pressure Relief (A3-08)

A3-08 indicates the motor's maximum reversed rotational speed at pressure relief. It is a percentage to the maximum rotational speed (A3-01). The smaller the value, the slower the pressure relief will be. The greater the value, the faster the pressure relief will be. But this may cause pump reversal noise.

3.3.6 Min. Flow and Min. Pressure (A3-09, A3-10)

Because the pump has internal leakage, the hydraulic oil in the oil circuit oil tanks will reflow to the oil tank when the system gives no flow and pressure command. As a result, air enters the oil circuit, causing system running noise and instability. Thus, you need to set the min. flow (A3-09, a percentage of maximum rotational speed) and min. pressure (A3-10).

3.3.7 System Response (Oil Pressure PID Control)

The drive provides four groups of PID parameters. You can select a proper group according to combination of input terminals DI2 and DI3, shown as below:

DI3	DI2	PID Group
0	0	1st group of PID parameters: A3-05, A3-06, A3-07
0	1	2nd group of PID parameters: A3-11, A3-12, A3-13
1	0	3rd group of PID parameters: A3-14, A3-15, A3-16
1	1	4th group of PID parameters: A3-17, A3-18, A3-19

For a faster system response, increase the proportional gain K_p , reduce the integral gain K_i and lengthen the differential time K_d . Be aware that a fast system response will lead to system oscillation, overshoot and instability.

Conversely, decreasing the proportional gain K_p , increasing the integral gain K_i and shortening the differential time K_d the slower the response will be. This will lead to a reduction in efficiency and unstable product quality.



Operation and Display

Chapter 4 Operation and Display

4.1 Operation Panel

You can modify the servo drive's parameters, monitor the servo drive's working status and run/stop the servo drive via the operation panel shown as below:



4.1.1 Description of Indicators

- **RUN**
OFF indicates that the servo drive is in the stop status, and ON indicates that the servo drive is in the running status.
- **LOCAL/REMOT:**
It indicates whether the servo drive is operated via operation panel, terminals or communication.

○LOCAL/REMOT: OFF	Operation panel
●LOCAL/REMOT: ON	Terminals
◐LOCAL/REMOT: flashing	Communication

- FWD/REV:
OFF indicates forward rotation, and ON indicates reverse rotation.
- TUNE/TC:
ON indicates the torque control mode, OFF indicates the speed control mode and flashing indicates the tuning status.
- $\overset{\text{Hz}}{\circ}$ — RPM — $\overset{\text{A}}{\circ}$ —%— $\overset{\text{V}}{\circ}$ Unit Indicators(● Indicates ON, ○ Indicates OFF)
 - $\overset{\text{Hz}}{\bullet}$ — RPM — $\overset{\text{A}}{\circ}$ —%— $\overset{\text{V}}{\circ}$ Hz: unit of frequency
 - $\overset{\text{Hz}}{\circ}$ — RPM — $\overset{\text{A}}{\bullet}$ —%— $\overset{\text{V}}{\circ}$ A: unit of current
 - $\overset{\text{Hz}}{\circ}$ — RPM — $\overset{\text{A}}{\circ}$ —%— $\overset{\text{V}}{\bullet}$ V: unit of voltage
 - $\overset{\text{Hz}}{\bullet}$ — RPM — $\overset{\text{A}}{\bullet}$ —%— $\overset{\text{V}}{\circ}$ RPM: unit of rotational speed
 - $\overset{\text{Hz}}{\circ}$ — RPM — $\overset{\text{A}}{\bullet}$ —%— $\overset{\text{V}}{\bullet}$ % : percentage

4.1.2 Digital Display

The 5-digit LED display is able to display the set frequency, output frequency, monitoring data and error codes.

4.1.3 Description of Keys on the Operation Panel

Key	Name	Function
PRG	Programming key	Enter or exit level I menu.
ENTER	Confirm key	Enter the menu interfaces level by level, and confirm the parameter setting.
△	Increase key	Increase data or function code.
▽	Decrease key	Decrease data or function code.
▷	Shift key	Select the displayed parameters in turn on the stop display interface and running display interface, and select the modification digit of parameters when modifying parameters.
RUN	Run key	Press this key to start the servo drive in the operation panel control mode.

STOP/ RES	Stop/Reset key	Press this key to stop the running in the running status and reset the operation in the fault status. This function is limited by function code F7-02.
QUICK	Shortcut key	Enter or exit level I menu of the shortcut menu. For details, see description of QUICK operation.
MF.K	Multi-function key	F7-01=0, it has no function. F7-01=1, it is the key for switch over between local operation and remote operation F7-01=2, it is the key for forward/reverse rotation switchover. F7-01=3, it is the key for forward JOG. For details, see description of F7-01.

4.2 How to Query and Modify Function Codes

IS300's operation panel adopts three-level menu, convenient for quick querying and modification of parameters.

The three-level menu consists of function code group number (Level I), function code (Level II), and function code value (level III), shown as below:

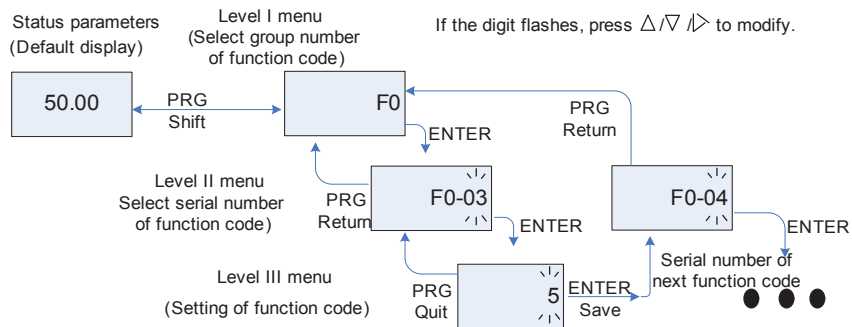

You can return to Level II from Level III by pressing PRG or ENTER:

- After you press ENTER, the system saves parameter setting first, and then goes back to Level II and shifts to the next function code.
- After you press PRG, the system does not save parameter setting, but directly returns to Level II and keeps staying at the current function code.

Here is an example of changing the value of F3-02 from 10.00 Hz to 15.00 Hz:

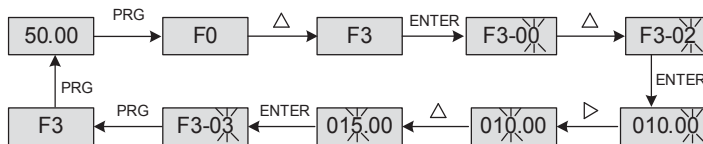

In Level III menu, if the parameter has no flashing bit, it means that the parameter cannot be modified. This may be because:

- Such function code is readable parameter, like inverter type, actually detected parameter and running record parameter.
- Such function code cannot be modified in the running status and can only be changed after the inverter stops.

4.3 QUICK Operation

The QUICK key on the operation panel enables you to query the parameters in the shortcut menu. The setup of the shortcut menu is aimed to facilitate the user to query and modify the commonly used parameters quickly.

The parameter is displayed as "uA3-01" in the shortcut menu, indicating parameter A3-01. Modification of parameter in the shortcut menu has the same effect as the modification in common status.

Up to 16 parameters can be saved in the shortcut menu. If there have been 16 parameters, "FULL" will be displayed for new adding. If "NULL" is displayed, it indicates that the shortcut menu is null. The operation of the shortcut menu is restricted by F7-03. If F7-03 is set to 0, you can increase/decrease parameters in the shortcut menu. If it is set to 1, you cannot perform increment/decrement operation.

A total of 16 parameters are stored in the shortcut menu after initialization, shown as below:

uA3-01	Max. rotational sped	uA3-09	Bottom flow
uA3-02	System oil pressure	uA3-10	Bottom pressure
uA3-03	Max. oil pressure	uA3-11	AI null shift atuto correction
uA3-04	Oil pressure command rise time	uA3-12	Speed loop proportional gain 1
uA3-05	Oil pressure control Kp1	uA3-13	Speed loop integral time 1
uA3-06	Oil pressure control Ti1	uA3-14	Speed loop proportional gain 2
uA3-07	Oil pressure control Td1	uA3-15	Speed loop integral time 2
uA3	Max. reverse rotational sped	uA3-16	A13 input filter time

4.3.1 Saving Parameters to Shortcut Menu



Press the QUICK key in the Level II menu of PRG. The display flashes to prompt whether to save the parameter to the shortcut menu. Then if you press ENTER, the display stops flashing and the saving is complete. If you press PRG, the display stops flashing and the saving is cancelled.

4.3.2 Modifying Parameters in Shortcut Menu

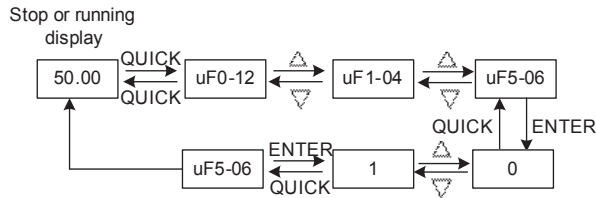

On the stop or running display interface, press QUICK to enter the shortcut menu. Then you can select the parameter via the UP/DOWN key. Then press ENTER to enter the Level III menu. Here the parameter modification is the same as that in common Level III menu. To return to Level II menu, press QUICK. The modification will not be saved.

4.3.3 Deleting Parameters from Shortcut Menu

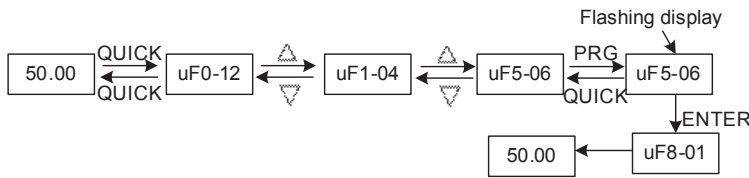

In the shortcut menu, press PRG. The display flashes to prompt whether to delete the parameter. Then if you press ENTER, the display stops flashing and the deletion is complete. If you press QUICK, the display stops flashing and the deletion is cancelled. If the last shortcut parameter is deleted, "Null" will be displayed then.

4.4 Querying Status Parameters

In the stop or running status, parameters in multiple statuses can be displayed. You can select whether to display the parameter according to selection of the binary bits of F7-04 (running parameters) and F7-05 (stop parameters).

In the running status, five running status parameters are always displayed, namely, running frequency, set frequency, bus voltage, output voltage and output current. Whether the other 16 parameters are displayed is determined by the setting of F7-04. The 16 parameters include DI input status, DO output status, AI1 voltage, AI2 voltage, AI3 voltage (current) and 4 reserved parameters. Press the key to switchover the display of the parameters in sequence.

In the stop status, a total of 16 stop status parameters can be selected, namely, set frequency, bus voltage, DI input status, DO output status, AI1 voltage, AI2 voltage, AI3 voltage (current) and 5 reserved parameters. Whether to display the 16 parameters is determined by the setting of F7-05. Press the key to switchover the display of the parameters in sequence.

When the servo drive is re-powered on after power failure, the displayed parameters are the parameters selected before the power failure by default.

4.5 Password Setting

The servo drive provides user password protection function. When FP-00 is set to non-zero value, the value is the user password. The password protection becomes valid after exiting the parameter editing status. When pressing PRG key again, "-----" will be displayed, and common menu cannot be entered until user password is input correctly.

To cancel the password protection function, enter with password and set FP-00 to 0. The user password protection on the parameters in the short-cut menu is determined by the status of F7-03 but is invalid for parameter value.

■ Super Password

If you forget the password set in FP-00, please do as follows:

1. Press PRG to display "-----".
2. Press key "SHIFT". The cleartext will be displayed.
3. Record the cleartext and send it to the factory for decryption. If encryption fails within 6 hours or the system is re-powered on during 6 hours, obtain the cleartext again.

4.6 Motor Tuning

If vector control is selected, the motor nameplate parameters must be entered correctly. The vector control mode is dependent on the motor parameters. To implement better control performance, correct motor parameters must be obtained.

To perform motor tuning, do as follows:

1. Set the command source (F0-02) to 0 (operation panel).
2. Input the following parameters based on the actually selected motor.
 - F1-01: Rated motor power
 - F1-02: Rated motor voltage
 - F1-03: Rated motor current
 - F1-04: Rated motor frequency
 - F1-05: Rated motor rotational speed
3. If the counter EMF of the motor is unknown, please disconnect the motor from the load and set F1-16 to 2 (dynamic tuning). Then press the key RUN on the operation panel. The servo drive will automatically calculate the value of the following motor parameters:
 - F1-11: D-shaft inductance
 - F1-12: Q-shaft inductance
 - F1-13: Stator resistance
 - F1-14: Unit
 - F1-15: Counter electromotive force
 - A1-02: Encoder installation angle

The dynamic motor tuning is complete.

4. If the counter EMF of the motor is known, please set F1-15 based on the actual value. Do not disconnect the motor from the load and set F1-16 to 1 (static tuning). Then press the key RUN on the operation panel. The servo drive will automatically calculate the value of the following motor parameters:

F1-11: D-shaft inductance

F1-12: Q-shaft inductance

F1-13: Stator resistance

F1-14: Unit

A1-02: Encoder installation angle

The static motor tuning is complete.

The motor's counter EMF can be calculated based on the basic motor parameter, including rated counter EMF coefficient V1000 rpm (V/1000 rpm) and rated rotational speed v (rpm). The formula is $V_{emf} = V1000 * v / 1000$.



Troubleshooting

Chapter 5 Troubleshooting

5.1 Faults and Solutions

IS300 has alarm information and protective function. When a fault occurs, the protective function will act and the servo drive will stop output. Then the fault relay contact of the drive will act and the error code will be displayed on the operation panel.

Before consulting the service department, the user should read the instructions in this chapter to find the cause of the fault and its corresponding solution. If you still cannot solve the problem, please feel free to contact the agent or our company.

- Err01 (Reserved)
- Err02 (Over-current During Acceleration)

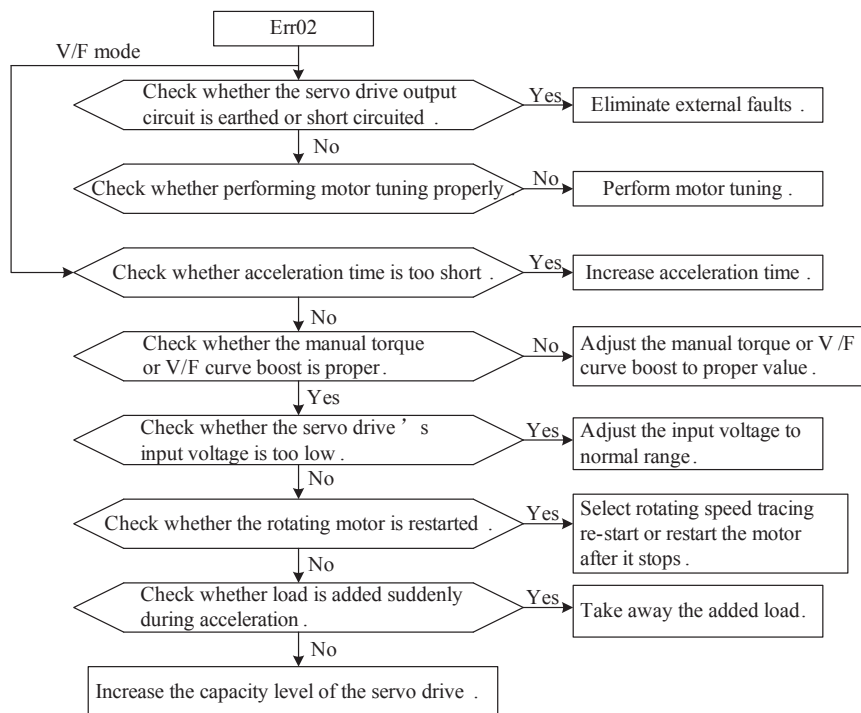

■ Err03 (Over-current During Deceleration)

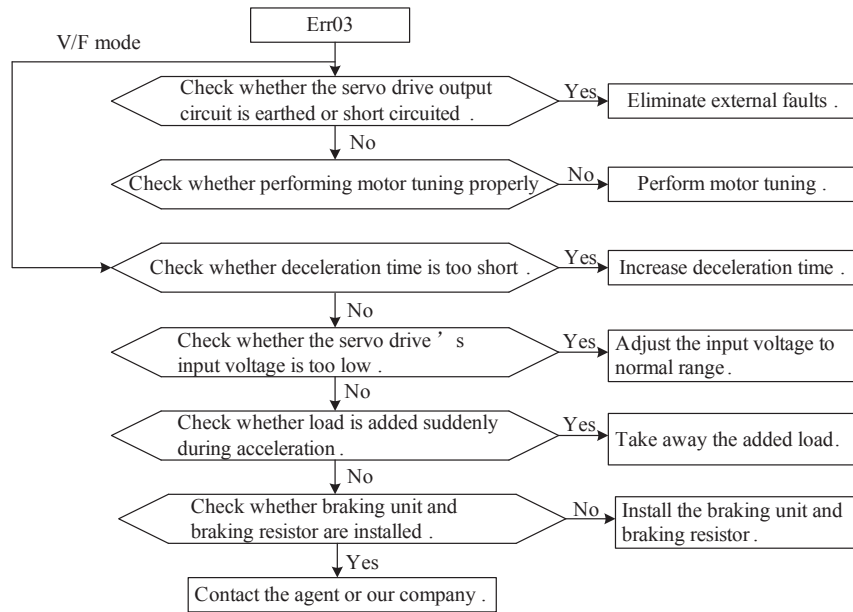

■ Err04 (Over-current at Constant Speed)

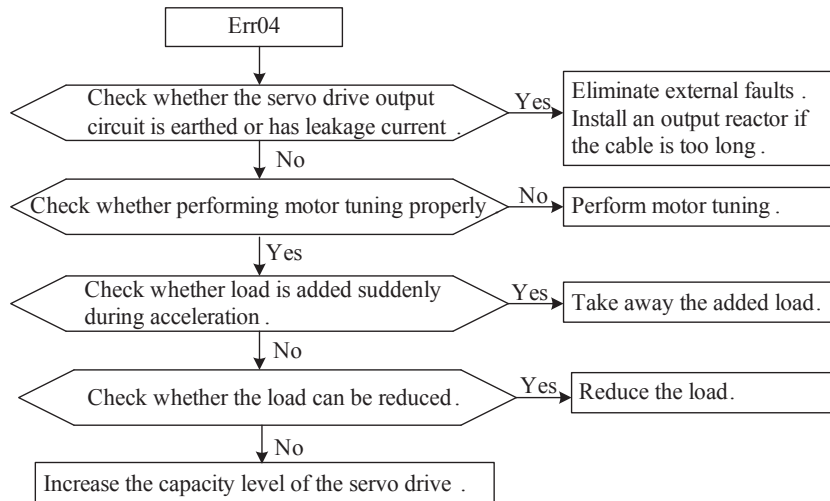

■ Err05 (Over-voltage During Acceleration)

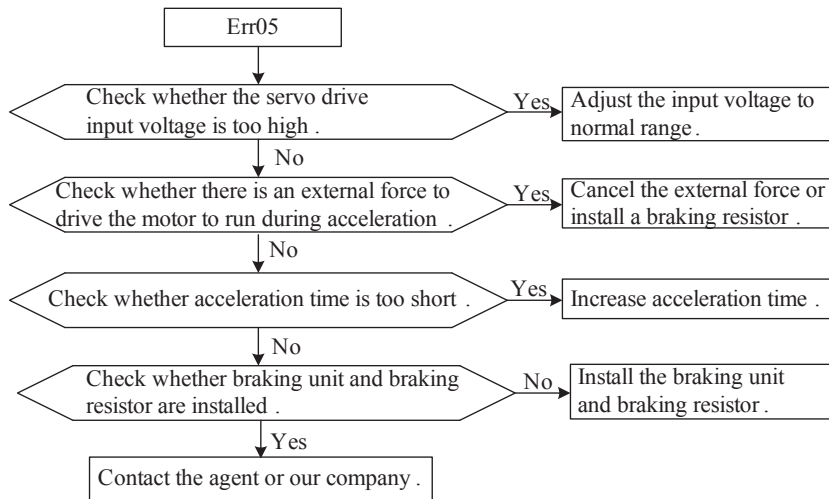

■ Err06 (Over-voltage During Deceleration)

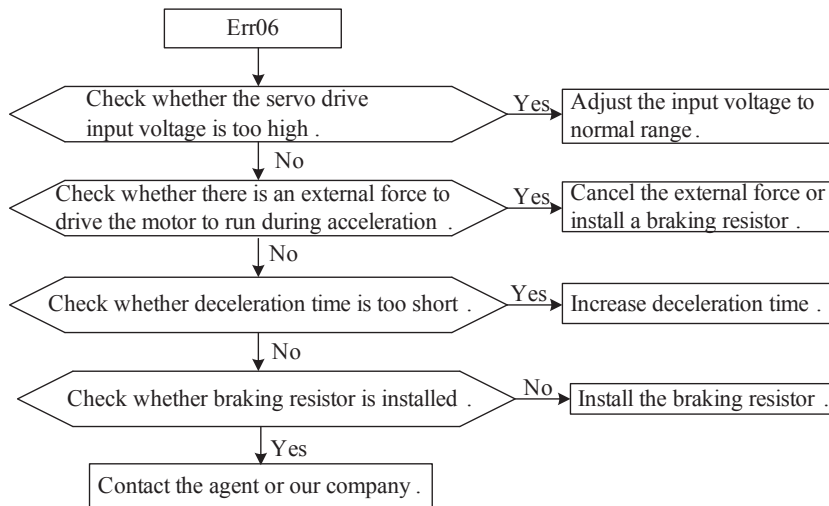

■ Err07 (Over-voltage at Constant Speed)

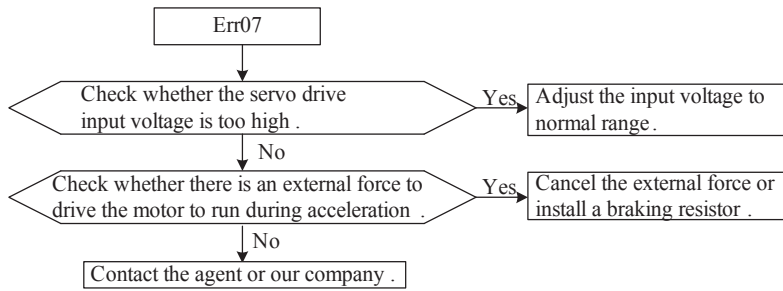

■ Err08 (Reserved)

■ Err09 (Undervoltage)

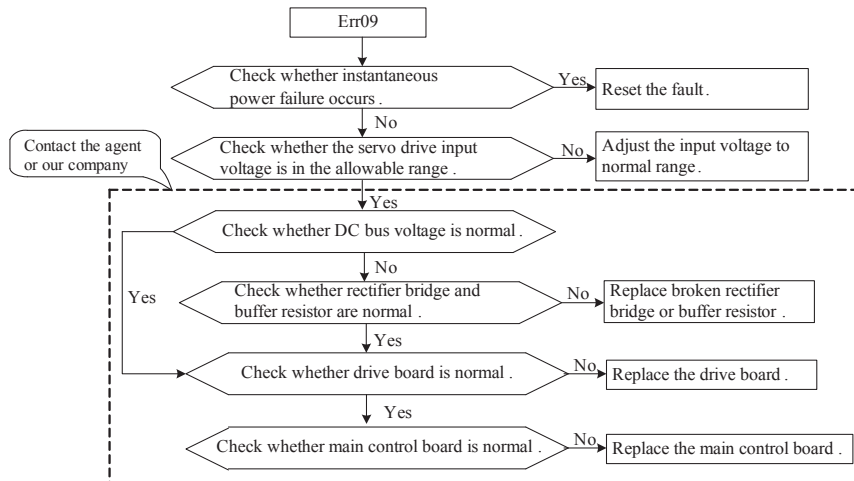

■ Err10/Err11 (Servo Drive/Motor Overload)

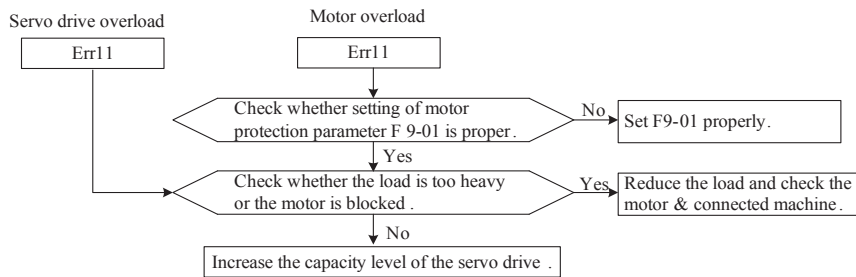

■ Err12 (Phase Loss at Input Side)

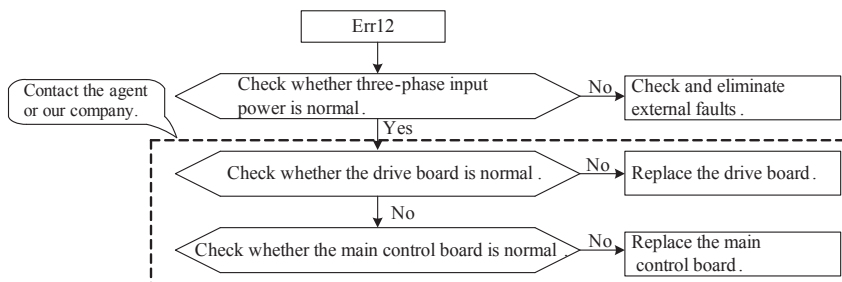

■ Err13 (Phase Loss at Output Side)

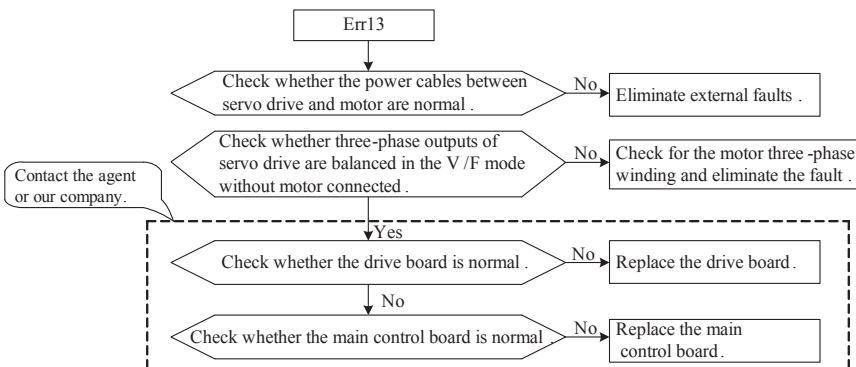

■ Err14 (Module Overheat)

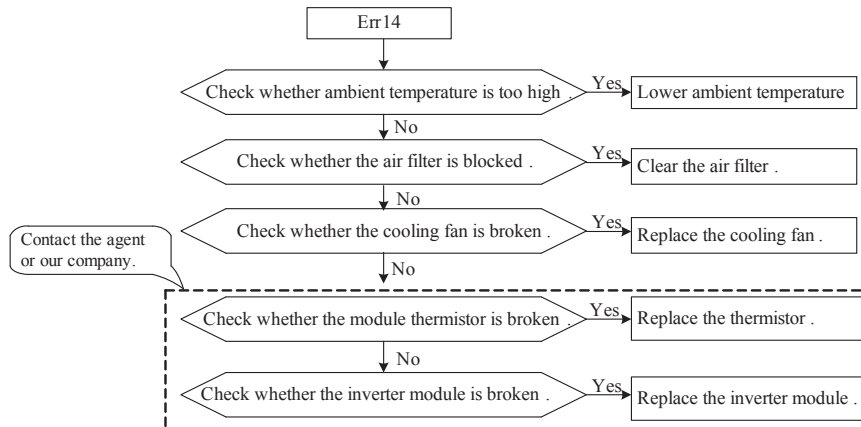

■ Err15 (External Machine Fault)

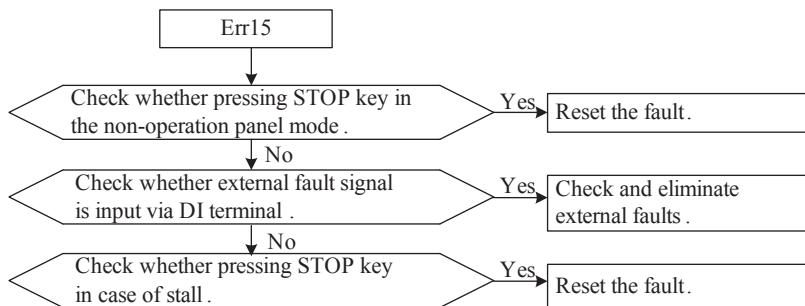

■ Err16 (Communication Fault)

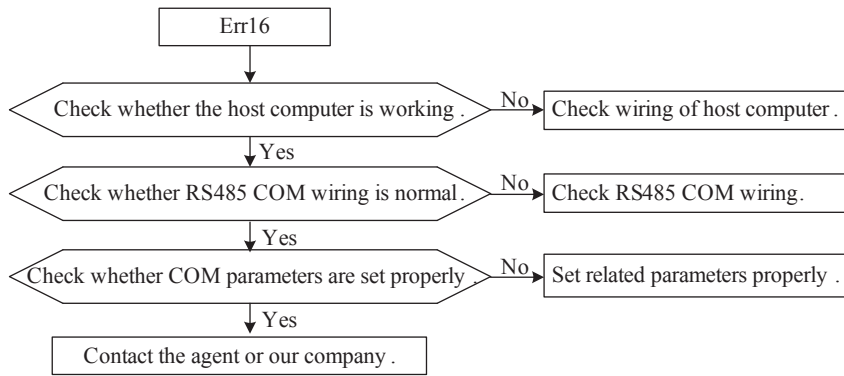

■ Err17 (Contactor Fault)

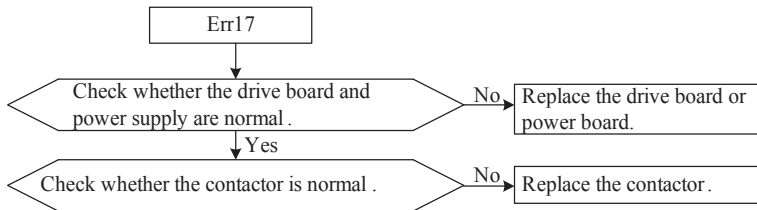

■ Err18 (Current Detection Fault)

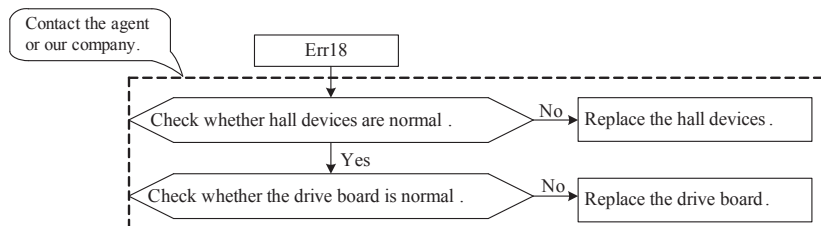

■ Err19 (Motor Tuning Fault)

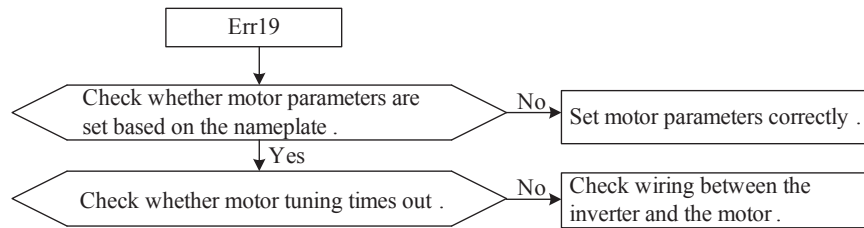

■ Err20 (Encoder Fault)

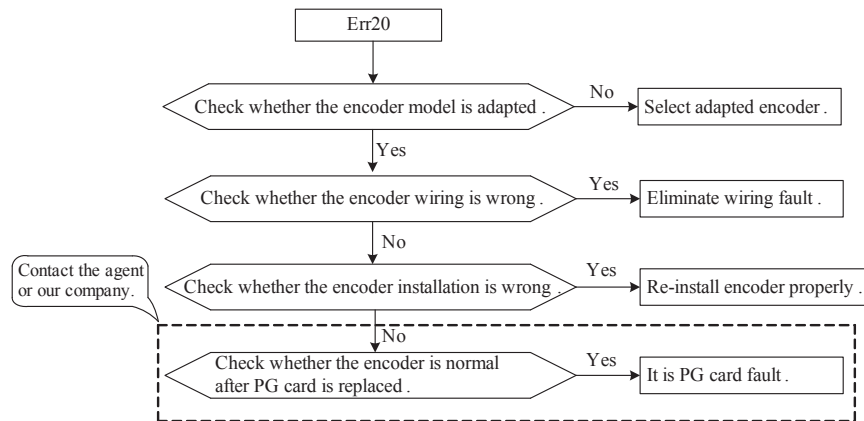

■ Err21 (Data Overflow)

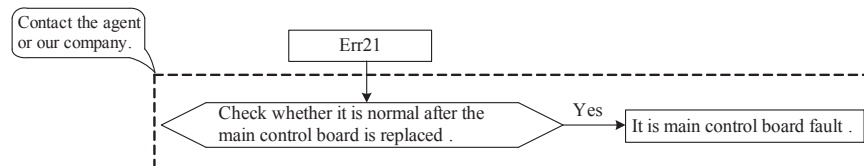

■ Err22 (Reserved)

■ Err23 (Short Circuit to Ground)

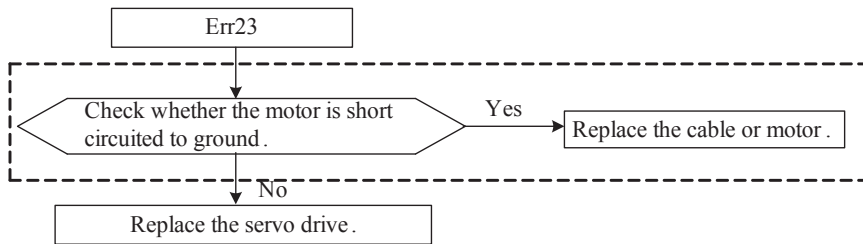

■ Err24-Err41 (Reserved)

■ Err42 (CAN COM Interruption)

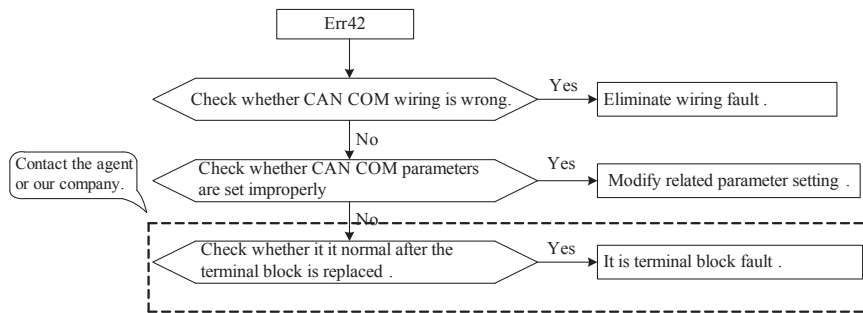

■ Err43 (Encoder Fault during Motor Tuning)

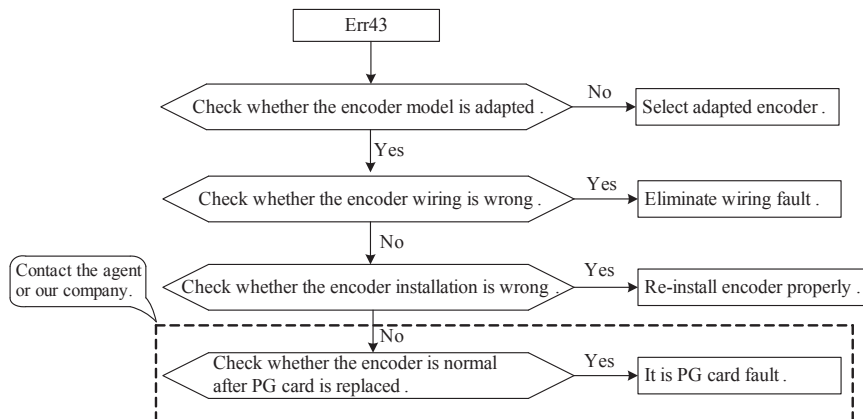

■ Err44 (Too Big Speed Deviation)

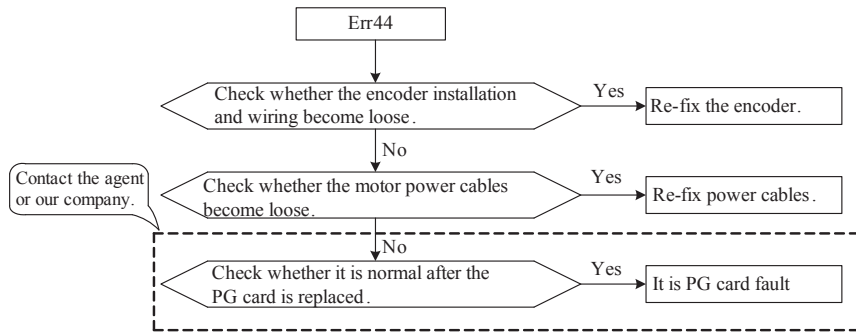

■ Err45 (Motor Overheat)

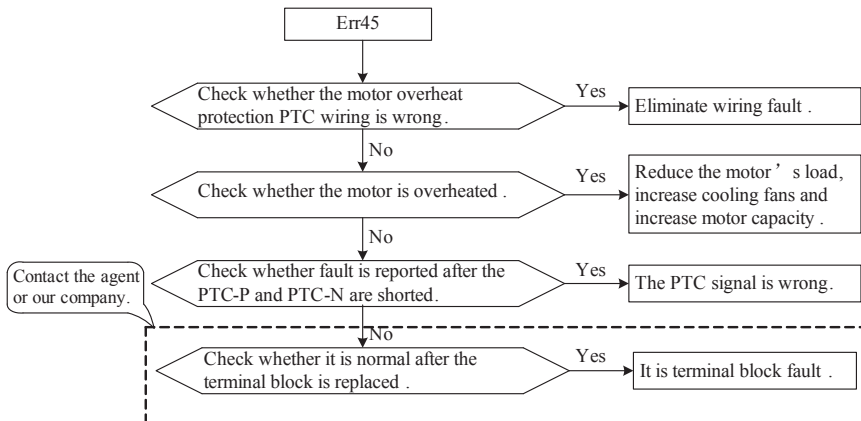

■ Err46 (Oil Pressure Transducer Fault)

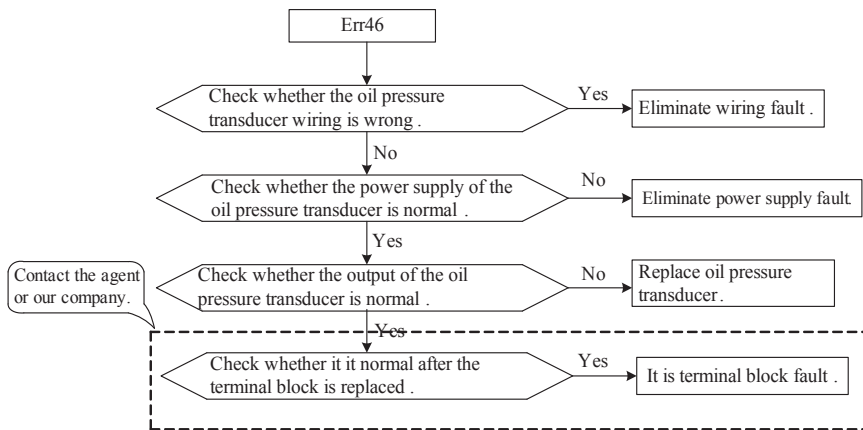

■ Err49 (Resolver Signal Fault)

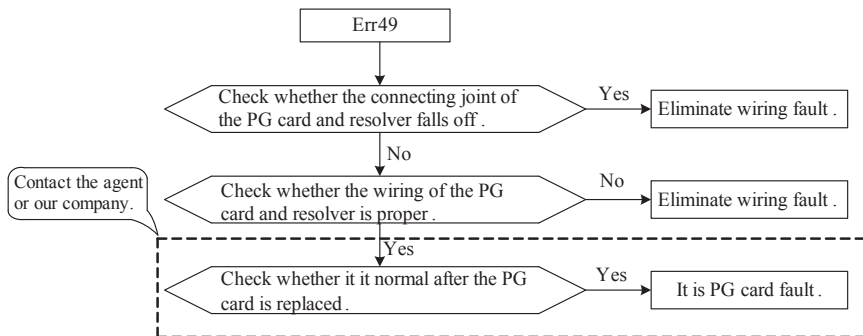

■ Err58 (Parameter Restoration Error)

Note

- Err47, Err48 and Err52 are the faults that occur when multiple pumps are connected in parallel. In single pump control mode, please cut off the input of DI5.
- If multi-pump parallel control shall be adopted, contact Inovance for the "multi-pump control solution" and refer to the description.

5.2 Common Faults and Solutions

The following faults may occur during the use of the servo drive. Refer to the following table for simple fault analysis.

SN	Fault	Possible Causes	Solutions
1	No display upon power-on	There is no power supply to the servo drive. The 8-core cable connecting the drive board and control board is in poor contact. The servo drive's internal parts are broken.	Check the power input. Re-connect the 8-core cable. Contact the agent or our company.
2	"HC" is displayed upon power-on.	The 4-core cable connecting the drive board and the control board is in poor contact. Other parts of the servo drive are broken.	Re-connect the 4-core cable. Contact the agent or our company.
3	"Err23" is displayed upon power-on.	The motor or the motor output cable is short circuited to the ground. The servo drive is damaged.	Measure the insulation of the motor and the output cable with megger. Contact the agent or our company.
4	The servo drive display is normal upon power-on. But it displays "HC" after running and stops immediately.	Cooling fan is broken or does not rotate.	Replace the cooling fan.
5	Err14 (module overheat) is reported frequently.	The setting of carrier frequency is too high. Cooling fan is broken, or the air filter is clogged. The internal parts (thermal coupler or others) of the servo drive are damaged.	Lower the carrier frequency (F0-15). Replace the cooling fan and clean the air filter. Contact the agent or our company.
6	The motor does not rotate after the servo drive runs	The motor is broken or clogged. The parameters are set improperly (motor parameters in group F1).	Replace the motor or clear mechanical faults. Check and re-set motor parameters.
7	DI terminal disabled	The parameter is set wrongly. The jumper across OP and +24V becomes loose. Control board is faulty.	Check and reset the group F4 parameters. Re-connect the cables. Contact our company.
8	In closed-loop vector control, the motor speed is always low.	The encoder is broken or the encoder wiring is wrong. The servo drive's internal parts are broken.	Replace the encoder and ensure the cabling is proper. Contact the agent or our company.

SN	Fault	Possible Causes	Solutions
9	Inverter reports over-current and over-voltage error frequently.	Setting of motor parameters is incorrect. Acceleration/Deceleration time is incorrect. Load fluctuates.	Re-set motor parameters or perform motor tuning. Set proper acceleration/ deceleration time. Contact the agent or our company.
10	Err17 is reported upon power-on or running.	The soft startup contactor has not closed.	Check whether: <ul style="list-style-type: none"> • The contactor cable is loose. • The contactor is faulty • The contactor 24 V power supply is faulty. Contact the agent or our company.



**ISMG Servo Motor
(Voltage Class: 400V)**

Chapter 6 ISMG Servo Motor (Voltage Class: 400V)

6.1 ISMG Servo Motor Designation Rules

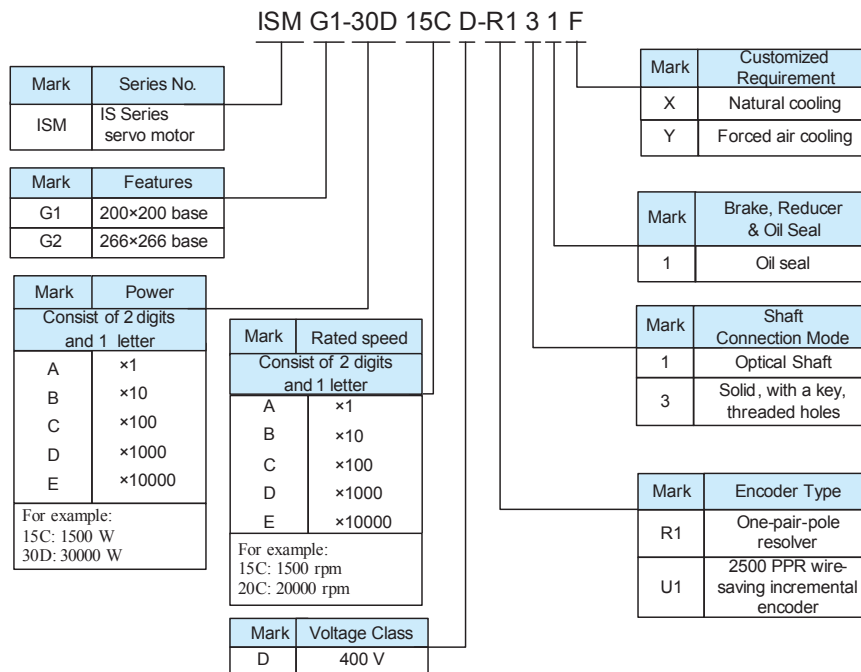

■ Motor Duty Types

Motor duty types indicate the loads the motor drives, with a sequence of identical operations, involving starts, stops braking, speed control and reversals, with intermittent idle running and de-energized periods.

- S1: Continuous running duty

The operation of a motor at a rated load may take an unspecified time period to reach thermal equilibrium.

- S4: Intermittent periodic duty with start

This is a sequence of identical duty cycles, each consisting of a start period, an operation at constant load period, followed by a stationary and de-energized period. This cycle has a great impact on temperature rise.

6.2 ISMG Servo Motor Specification Parameters

6.2.1 ISMG1 Servo Motor (200×200 Base/Forced Air Cooling)

Model (1)	Rated Torque (Nm)		Rated Rotational speed (rpm)	Counter EMF (V)	Rated Voltage		Rated Current		Rated Power	
	S1 (2)	S4 (2)			S1 (2)	S4 (2)	S1 (2)	S4 (2)	S1 (2)	S4 (2)
ISMG1-95C15CD-R131F	55	60	1500	305	335	340	18	19	8.5	9.5
ISMG1-11D17CD-R131F			1700	296	334	338	22	23	10.0	11.0
ISMG1-12D20CD-R131F			2000	291	327	331	24	26	11.5	12.6
ISMG1-14D15CD-R131F	75	90	1500	291	325	332	25	30	13.0	14.1
ISMG1-16D17CD-R131F			1700	296	328	333	29	34	14.5	16.0
ISMG1-18D20CD-R131F			2000	310	335	340	31	36	17.0	18.8
ISMG1-22D15CD-R131F	115	135	1500	305	342	348	36	41	19.0	22.0
ISMG1-24D17CD-R131F			1700	296	332	338	43	50	21.5	24.0
ISMG1-28D20CD-R131F			2000	291	322	328	47	54	25.5	28.3
ISMG1-30D15CD-R131F	150	195	1500	291	324	333	48	61	25.0	30.6
ISMG1-41D20CD-R131F			2000	310	334	343	60	76	33.0	41.0

Note: (1) Motor models of forced air cooling method are defined by duty type S4.

(2) S1: duty type S1; (S4): duty type S4.

Model (1)	Torque Constant (Nm/A)	Counter EMF Constant (V/rpm)	Max. Torque (Nm)	Max. Rotational speed (rpm)	Rotor Inertia ($\text{kgm}^2 \cdot 10^{-3}$)	Number of Poles
ISMG1-95C15CD-R131F	3.24	0.203	160	2000	7.5	8
ISMG1-11D17CD-R131F	2.68	0.174	160	2210	7.5	8
ISMG1-12D20CD-R131F	2.39	0.146	160	2500	7.5	8
ISMG1-14D15CD-R131F	3.01	0.194	230	2000	9.0	8
ISMG1-16D17CD-R131F	2.75	0.174	230	2210	9.0	8
ISMG1-18D20CD-R131F	2.55	0.155	230	2500	9.0	8
ISMG1-22D15CD-R131F	3.31	0.203	340	2000	12.0	8
ISMG1-24D17CD-R131F	2.76	0.174	340	2210	12.0	8
ISMG1-28D20CD-R131F	2.53	0.146	340	2500	12.0	8
ISMG1-30D15CD-R131F	3.20	0.194	450	2000	15.0	8
ISMG1-41D20CD-R131F	2.58	0.155	450	2500	15.0	8

Note: (1) Motor models of forced air cooling method are defined by duty type S4.

(2) S1: duty type S1; (S4): duty type S4.

IMPORTANT

Models in grey are commonly used models of servo pump .

6.2.2 ISMG2 Servo Motor (266×266 Base/Forced Air Cooling)

Model (1)	Rated Torque (Nm)		Rated Rotational speed (rpm)	Counter EMF (V)	Rated Voltage		Rated Current		Rated Power	
	S1 (2)	S4 (2)			S1 (2)	S4 (2)	S1 (2)	S4 (2)	S1 (2)	S4 (2)
ISMG2-20D15CD-R131F	116	130	1500	291	346	353	41	45	18.2	20.4
ISMG2-23D17CD-R131F			1700	296	351	358	45	50	20.6	23.1
ISMG2-27D20CD-R131F			2000	310	365	372	51	57	24.3	27.2
ISMG2-31D15CD-R131F	75	90	1500	305	358	364	56	65	26.7	31.4
ISMG2-36D17CD-R131F			1700	296	349	355	65	76	30.3	35.6
ISMG2-42D20CD-R131F			2000	291	344	350	78	92	35.6	41.9
ISMG2-42D15CD-R131F	230	270	1500	291	341	348	79	92	36.1	42.4
ISMG2-48D17CD-R131F			1700	296	346	353	88	102	40.9	48.1
ISMG2-57D20CD-R131F			2000	310	360	367	99	115	48.2	56.5
ISMG2-60D15CD-R131F	340	385	1500	305	353	360	110	125	53.4	60.5
ISMG2-68D17CD-R131F			1700	296	344	351	129	145	60.5	68.5
ISMG2-80D20CD-R131F			2000	291	339	346	154	174	71.2	80.6
ISMG2-80D15CD-R131F	440	510	1500	291	334	341	149	173	69.1	80.1
ISMG2-91D17CD-R131F			1700	329	372	379	149	173	78.3	90.8
ISMG2-11E20CD-R131F			2000	310	353	360	187	216	92.1	106.8

Note: (1) Motor models of forced air cooling method are defined by duty type S4.
(2) S1: duty type S1; (S4): duty type S4.

Model (1)	Torque Constant (Nm/A)	Counter EMF Constant (V/rpm)	Max. Torque (Nm)	Max. Rotational speed (rpm)	Rotor Inertia ($\text{kgm}^2 \cdot 10^{-3}$)	Number of Poles
ISMG2-20D15CD-R131F	2.981	0.194	325	1800	22.1	8
ISMG2-23D17CD-R131F	2.683	0.174	325	2040	22.1	8
ISMG2-27D20CD-R131F	2.385	0.155	325	2400	22.1	8
ISMG2-31D15CD-R131F	3.130	0.203	488	1800	29.6	8
ISMG2-36D17CD-R131F	2.683	0.174	488	2040	29.6	8
ISMG2-42D20CD-R131F	2.236	0.145	488	2400	29.6	8
ISMG2-42D15CD-R131F	2.981	0.194	650	1800	36.8	8
ISMG2-48D17CD-R131F	2.683	0.174	650	2040	36.8	8
ISMG2-57D20CD-R131F	2.385	0.155	650	2400	36.8	8

ISMG2-60D15CD-R131F	3.130	0.203	975	1800	50.0	8
ISMG2-68D17CD-R131F	2.683	0.174	975	2040	50.0	8
ISMG2-80D20CD-R131F	2.236	0.145	975	2400	50.0	8
ISMG2-80D15CD-R131F	2.981	0.194	1300	1800	64.0	8
ISMG2-91D17CD-R131F	2.981	0.194	1300	2040	64.0	8
ISMG2-11E20CD-R131F	2.385	0.155	1300	2400	64.0	8

Note: (1) Motor models of forced air cooling method are defined by duty type S4.

(2) S1: duty type S1; (S4): duty type S4.

IMPORTANT

Models in grey are commonly used models of servo pump .

6.2.3 ISMG1 Servo Motor (200×200 Base/Natural Cooling)

Model (1)	Rated Torque (Nm)		Rated Rotational speed (rpm)	Counter EMF (V)	Rated Voltage		Rated Current		Rated Power	
	S1 (2)	S4 (2)			S1 (2)	S4 (2)	S1 (2)	S4 (2)	S1 (2)	S4 (2)
ISMG1-55C15CD-R131X	35	43	1500	305	325	330	11	14	5.5	7.0
ISMG1-62C17CD-R131X			1700	296	318	325	13	17	6.2	8.0
ISMG1-75C20CD-R131X			2000	291	313	320	15	19	7.5	9.5
ISMG1-75C15CD-R131X	48	60	1500	291	312	320	16	21	7.5	9.7
ISMG1-85C17CD-R131X			1700	296	315	322	18	23	8.5	11.0
ISMG1-11D20CD-R131X			2000	310	325	330	20	25	11.0	13.0
ISMG1-11D15CD-R131X	70	85	1500	305	325	332	21	27	11.0	13.7
ISMG1-12D17CD-R131X			1700	296	316	322	26	32	12.0	15.5
ISMG1-15D20CD-R131X			2000	291	308	315	28	34	15.0	18.0
ISMG1-13D15CD-R131X	89	110	1500	291	309	315	28	35	13.0	18.0
ISMG1-18D20CD-R131X			2000	310	323	328	35	43	18.5	23.5

Note: (1) Motor models of forced air cooling method are defined by duty type S4.

(2) S1: duty type S1; (S4): duty type S4.

Model (1)	Torque Constant (Nm/A)	Counter EMF Constant (V/rpm)	Max. Torque (Nm)	Max. Rotational speed (rpm)	Rotor Inertia (kgm ² 10 ⁻³)	Number of Poles
ISMG1-55C15CD-R131X	3.24	0.203	160	2000	7.5	8
ISMG1-62C17CD-R131X	2.68	0.174	160	2210	7.5	8
ISMG1-75C20CD-R131X	2.39	0.146	160	2500	7.5	8
ISMG1-75C15CD-R131X	3.01	0.194	230	2000	9.0	8
ISMG1-85C17CD-R131X	2.75	0.174	230	2210	9.0	8
ISMG1-11D20CD-R131X	2.55	0.155	230	2500	9.0	8
ISMG1-11D15CD-R131X	3.31	0.203	340	2000	12.0	8
ISMG1-12D17CD-R131X	2.76	0.174	340	2210	12.0	8
ISMG1-15D20CD-R131X	2.53	0.145	340	2500	12.0	8
ISMG1-13D15CD-R131X	3.20	0.194	450	2000	15.0	8
ISMG1-18D20CD-R131X	2.58	0.155	450	2500	15.0	8

Note: (1) Motor models of forced air cooling method are defined by duty type S4.
(2) S1: duty type S1; (S4): duty type S4.

6.2.4 ISMG2 Servo Motor (266×266 Base/Natural Cooling)

Model (1)	Rated Torque (Nm)		Rated Rotational speed (rpm)	Counter EMF (V)	Rated Voltage		Rated Current		Rated Power	
	S1 (2)	S4 (2)			S1 (2)	S4 (2)	S1 (2)	S4 (2)	S1 (2)	S4 (2)
ISMG2-13D15CD-R131F	80	95	1500	291	321	326	29	34	12.6	14.9
ISMG2-14D17CD-R131F			1700	296	326	331	32	37	14.2	16.9
ISMG2-17D20CD-R131F			2000	310	340	345	36	42	16.8	19.9
ISMG2-18D15CD-R131F	115	140	1500	305	332	338	38	46	18.1	22.0
ISMG2-21D17CD-R131F			1700	296	323	329	45	54	20.5	24.9
ISMG2-24D20CD-R131F			2000	291	318	324	54	65	24.1	29.3
ISMG2-24D15CD-R131F	155	185	1500	291	316	321	54	64	24.3	29.1
ISMG2-28D17CD-R131F			1700	296	321	326	60	71	27.6	32.9
ISMG2-33D20CD-R131F			2000	310	335	340	67	80	32.5	38.7
ISMG2-35D15CD-R131F	220	260	1500	305	328	333	72	85	34.6	40.8
ISMG2-39D17CD-R131F			1700	296	319	324	84	99	39.2	46.3
ISMG2-46D20CD-R131F			2000	291	314	319	101	119	46.1	54.5
ISMG2-43D15CD-R131F	275	330	1500	291	309	314	94	112	43.2	51.8
ISMG2-49D17CD-R131F			1700	329	347	352	94	112	49.0	58.7
ISMG2-58D20CD-R131F			2000	310	328	333	117	140	57.6	69.1

Note: (1) Motor models of forced air cooling method are defined by duty type S4.
(2) S1: duty type S1; (S4): duty type S4.

Model (1)	Torque Constant (Nm/A)	Counter EMF Constant (V/rpm)	Max. Torque (Nm)	Max. Rotational speed (rpm)	Rotor Inertia (kgm ² 10 ⁻³)	Number of Poles
ISMG2-13D15CD-R131F	2.981	0.194	325	1800	22.1	8
ISMG2-14D17CD-R131F	2.683	0.174	325	2040	22.1	8
ISMG2-17D20CD-R131F	2.385	0.155	325	2400	22.1	8
ISMG2-18D15CD-R131F	3.130	0.203	488	1800	29.6	8
ISMG2-21D17CD-R131F	2.683	0.174	488	2040	29.6	8
ISMG2-24D20CD-R131F	2.236	0.145	488	2400	29.6	8
ISMG2-24D15CD-R131F	2.981	0.194	650	1800	36.8	8
ISMG2-28D17CD-R131F	2.683	0.174	650	2040	36.8	8
ISMG2-33D20CD-R131F	2.385	0.155	650	2400	36.8	8
ISMG2-35D15CD-R131F	3.130	0.203	975	1800	50.0	8
ISMG2-39D17CD-R131F	2.683	0.174	975	2040	50.0	8
ISMG2-46D20CD-R131F	2.236	0.145	975	2400	50.0	8
ISMG2-43D15CD-R131F	2.981	0.194	1300	1800	64.0	8
ISMG2-49D17CD-R131F	2.981	0.194	1300	2040	64.0	8
ISMG2-58D20CD-R131F	2.385	0.155	1300	2400	64.0	8

Note: (1) Motor models of forced air cooling method are defined by duty type S4.
 (2) S1: duty type S1; (S4): duty type S4.

6.3 ISMG Servo Motor Appearance and Mounting Dimensions

6.3.1 ISMG1 Servo Motor (200×200 Base/Forced Air Cooling)

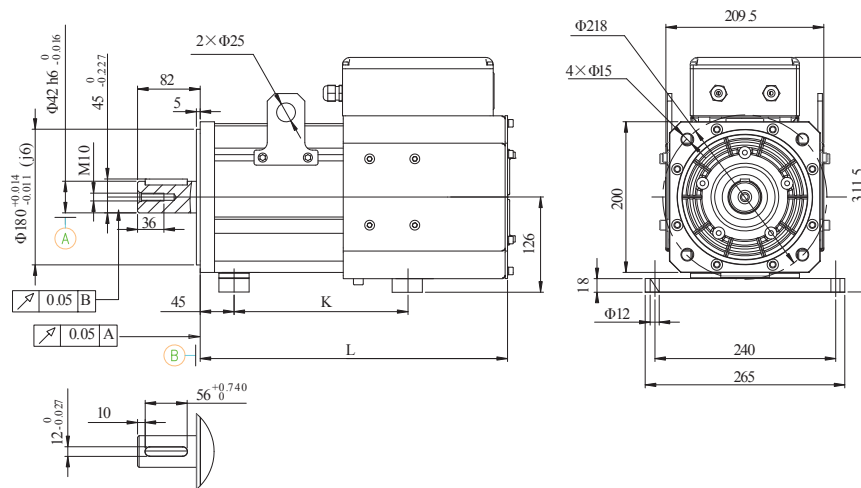

Item / Model	L	K
ISMG1-95C15CD-R131F ISMG1-11D17CD-R131F ISMG1-12D20CD-R131F	360	190
ISMG1-14D15CD-R131F ISMG1-16D17CD-R131F ISMG1-18D20CD-R131F	395	230
ISMG1-22D15CD-R131F ISMG1-24D17CD-R131F ISMG1-28D20CD-R131F	471	305
ISMG1-30D15CD-R131F ISMG1-41D20CD-R131F	550	380

6.3.2 ISMG2 Servo Motor (266×266 Base/Forced Air Cooling)

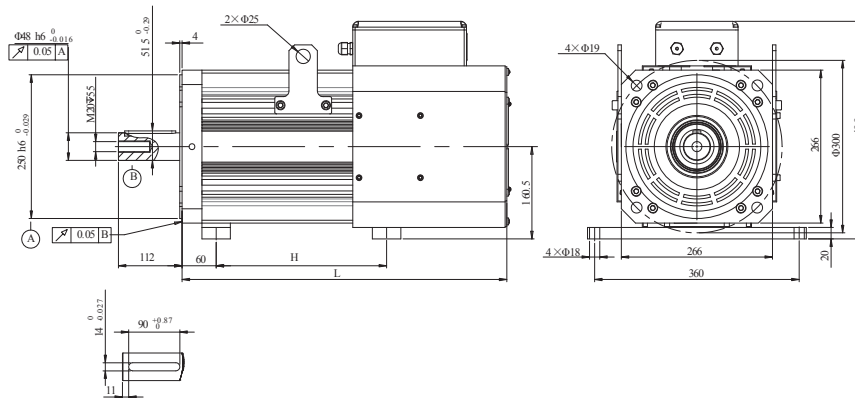

Item / Model	L	K
ISMG2-20D15CD-R131F ISMG2-23D17CD-R131F ISMG2-27D20CD-R131F	475	200
ISMG2-31D15CD-R131F ISMG2-36D17CD-R131F ISMG2-42D20CD-R131F	525	250
ISMG2-42D15CD-R131F ISMG2-48D17CD-R131F ISMG2-57D20CD-R131F	575	300

6.3.4 ISMG2 Servo Motor (266×266 Base/Natural Cooling)

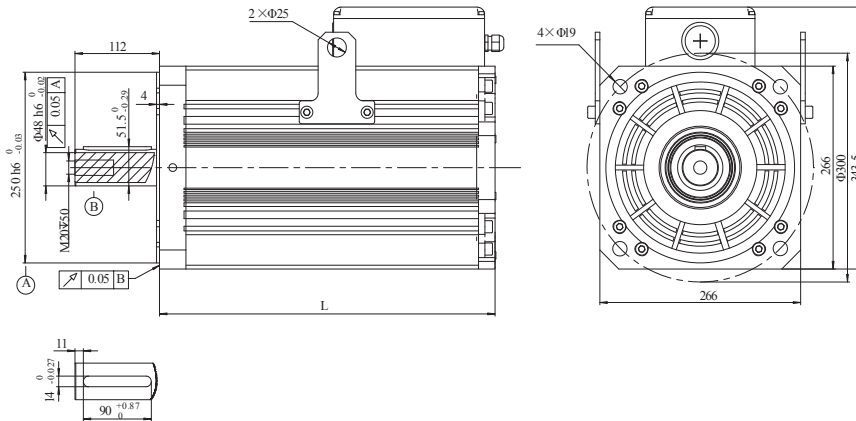

Item	Model	L	K
ISMG2-13D15CD-R131X ISMG2-14D17CD-R131X ISMG2-17D20CD-R131X		345	200
SMG2-18D15CD-R131X ISMG2-21D17CD-R131X ISMG2-24D20CD-R131X		395	250
ISMG2-24D15CD-R131X ISMG2-28D17CD-R131X ISMG2-33D20CD-R131X		445	300
ISMG2-35D15CD-R131X ISMG2-39D17CD-R131X ISMG2-46D20CD-R131X		550	400
ISMG2-43D15CD-R131X ISMG2-49D17CD-R131X ISMG2-58D20CD-R131X		650	500

6.4 Description of Supporting Board of ISMG Servo Motor Base

Model	Description
ISM1-B01	Used for ISMG1 servo motor (natural cooling)
ISM1-B02	Used for ISMG1 servo motor (cooling fan)
ISM2-B01	Used for ISMG2 servo motor (natural cooling)
ISM2-B02	Used for ISMG2 servo motor (cooling fan)

6.5 Wiring of ISMG Servo Motor

6.5.1 Terminals of PCB Board

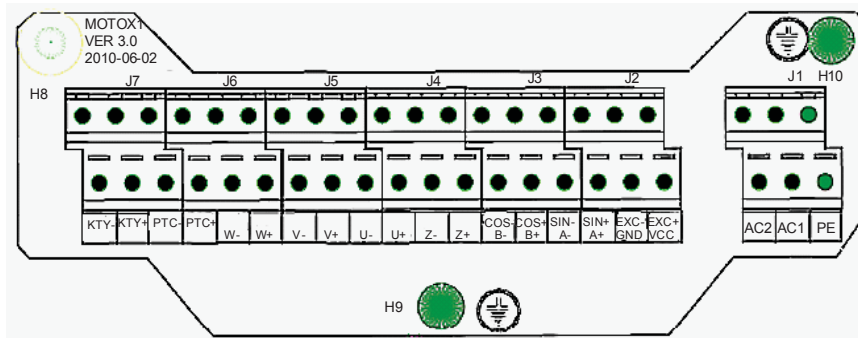

The signal types of the terminals are defined on the PCB board. AC1 and AC2 are power supply (single-phase 220 V) to the cooling fan. AC1 and AC2 should be wired strictly following the signs.

The matched signal lines of the IS300 servo drive are defined as below:

Signal Definition	EXC-	EXC+	SIN+	SIN-	COS+	COS-
Adapted Encoder Cable Color	Red	Blue	White	Brown	Yellow	Green
Corresponding IS300 PG Card Pin	1	2	3	4	5	9

6.5.2 Definition of Power Terminals Matched with PCB Board

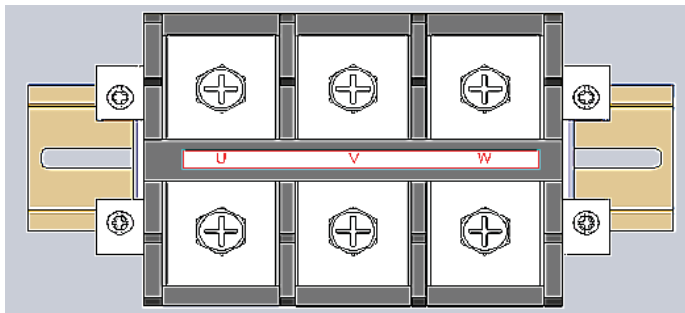

Note

- When wiring the main circuit, the phase sequence shall conform to the signs.
- Please connect PE terminal to the fixed screw in the connection box.



Appendix

Appendix

Appendix 1 Function Code Table

Function Code	Name	Setting Range	Min. Unit	Default	Property
Group U0: Querying Servo Drive Parameters					
U0-00	Running frequency	0.00 Hz–max. frequency (F0-10)	-	-	●
U0-01	Set frequency	0.00 Hz–max. frequency (F0-10)	-	-	●
U0-02	Bus voltage	0–830 V	-	-	●
U0-03	Output voltage	0 V–rated motor voltage (F1-02)	-	-	●
U0-04	Output current	0.01–655.35 A	-	-	●
U0-05	Output power	0.4–1000.0 kW	-	-	●
U0-06	Output torque	0.0%–torque upper limit (F2-10)	-	-	●
U0-07	Local DI/DO status		-	-	●
U0-08	Extended DI/DO status		-	-	●
U0-09	AI1 voltage (after corrected)	-10.00–10.000 V	-	-	●
U0-10	AI2 voltage (after corrected)	-10.00–10.000 V	-	-	●
U0-11	AI3 voltage (after corrected)	-10.00–10.000 V	-	-	●
U0-12 to U0-29	Reserved	-	-	-	●
U0-30	AI1 voltage (before corrected)	-10.00–10.000 V	-	-	●
U0-31	AI2 voltage (before corrected)	-10.00–10.000 V	-	-	●
U0-32	AI3 voltage (before corrected)	-10.00–10.000 V	-	-	●
U0-33	Reserved	-	-	-	●
U0-34	AO1 output voltage	0.000–10.000 V	-	-	●
U0-35	AO2 output voltage	0.000–10.000 V	-	-	●
Group U1: Querying Servo Pump Parameters					

Function Code	Name	Setting Range	Min. Unit	Default	Property
U1-00	Real-time angle	0.0° –359.9°	-	-	●
U1-01	Reference oil pressure	0.0 kg–system oil pressure (A3-02)	-	-	●
U1-02	Feedback oil pressure	0.0 kg–max. oil pressure (A3-03)	-	-	●
U1-03	Motor rotational speed	-9999–30000rpm	-	-	●
U1-04	AI1 voltage	-10.00–10.000 V	-	-	●
U1-05	AI2 voltage	-10.00–10.000 V	-	-	●
U1-06	AI3 voltage	-10.00–10.000 V	-	-	●
U1-07	AI1 null shift	-10.00–10.000 V	-	-	●
U1-08	AI2 null shift	-10.00–10.000 V	-	-	●
U1-09	AI3 null shift	-10.00–10.000 V	-	-	●
U1-10	Reference flow	0.00 Hz–max. frequency (F0-10)	-	-	●
U1-11	Resolver signal interference degree	0–1000	-	-	●
U1-12	Reserved	-	-	-	●
U1-13	CAN COM interference status	0–128	-	-	●
U1-14	Number of CAN sendings	0–65535	-	-	●
U1-15	Number of CAN receivings	0–65535	-	-	●
Group A0: Weak Magnetism and SVC Control Group					
A0-00	Weak magnetism control mode	0: Direct calculation 1: Automatic adjustment	1	0	★
A0-01	Weak magnetism current coefficient	80%–200%	1	100%	★
A0-02	Weak magnetism current upper limit	0–120	1	100	★
A0-03	Weak magnetism Integral multiples	200–1000	1	400	★
A0-04	Weak magnetism coefficient	0–100	1	4	★
A0-05	Output phase loss PWM detection time	0–63000	1	0	★
Group A1: PG Card Parameters					

Function Code	Name	Setting Range	Min. Unit	Default	Property
A1-00 to A1-01	Reserved	-	-	-	★
A1-02	Encoder installation angle	0.0° -359.9°	0.1°	0.0°	☆
A1-03	Select the reverse direction of feedback speed	0-1	1	0	★
A1-04	Number of pair poles of resolver	1-50	1	1	★
A1-05	Resolver signal fault detection time	0.000: Detection invalid 0.001s-60.000s	0.001s	0.000	☆
Group A2: CAN COM parameters					
A2-00	Baud rate selection	0: 20k 1: 50k 2: 125k 3: 250k 4: 500k 5: 1M	1	5	☆
A2-01	CAN COM address	1-255	1	1	☆
A2-02	CAN COM continuous time	0.0S: Invalid 0.1-600.0s	0.1s	0.3s	☆
A2-03	CAN multi-pump mode	0: Broadcast mode 1: Multi-master mode	1	0	☆
A2-04	CAN slave address 1	0-65535	1	0	☆
A2-05	CAN slave address 2	0-65535	1	0	☆
A2-06	CAN slave address 3	0-65535	1	0	☆
A2-07	CAN slave address 4	0-65535	1	0	☆
Group A3: Pump Control Parameters					
A3-00	Oil pressure control mode	0: Non-oil pressure control mode 1: Driver oil pressure control mode 1 (via CAN COM) 2: Driver oil pressure control mode 2 (via AI) 3: CAN oil pressure mode (For special use) 4: Reserved	0	0	★

Function Code	Name	Setting Range	Min. Unit	Default	Property
A3-01	Max. rotational sped	Rotational sped corresponding to lower limit of max. frequency–30000 rpm	1 rpm	2000 rpm	★
A3-02	System oil pressure	0.0 kg/cm ² –Max. oil pressure (A3-03)	0.0 kg/cm ²	175.0 kg/cm ²	☆
A3-03	Max. oil pressure	System oil pressure (A3-02) –500.0 kg/cm ²	0.0 kg/cm ²	250.0 kg/cm ²	☆
A3-04	Oil pressure command risetime	0–2000 ms	1ms	20ms	☆
A3-05	Oil pressure control Kp1	0.0–800.0	0.1	210.0	☆
A3-06	Oil pressure control Ti1	0.001–10.000s	0.001s	0.100s	☆
A3-07	Oil pressure control Td1	0.000–1.000s	0.001s	0.000s	☆
A3-08	Max. reversed rotational sped	0.0%–100.0%	0.1%	20.0%	☆
A3-09	Min. flow	0.0%–50.0%	0.1%	0.5%	☆
A3-10	Min. flow	0.0–50.0 kg/cm ²	0.1 kg/cm ²	0.5 kg/cm ²	☆
A3-11	Oil pressure control Kp2	0.0–800.0	0.1	210.0	☆
A3-12	Oil pressure control Ti2	0.001–10.000s	0.001s	0.100s	☆
A3-13	Oil pressure control Td2	0.000–1.000s	0.001s	0.000s	☆
A3-14	Oil pressure control Kp3	0.0–800.0	0.1	210.0	☆
A3-15	Oil pressure control Ti3	0.001–10.000s	0.001s	0.100s	☆
A3-16	Oil pressure control Td3	0.000–1.000s	0.001s	0.000s	☆
A3-17	Oil pressure control Kp4	0.0–800.0	0.1	210.0	☆
A3-18	Oil pressure control Ti4	0.001–10.000s	0.001s	0.100s	☆
A3-19	Oil pressure control Td4	0.000–1.000s	0.001s	0.000s	☆
A3-20	AI null shift auto correction	0: Disabled 1: Enabled	0	0	☆
A3-21	Fault detection time of oil pressure transducer	0.000s: Detection invalid 0.001–60.000s	0.001s	0.500s	☆

Function Code	Name	Setting Range	Min. Unit	Default	Property
A3-22	Setting of max. output speed in pressure control	0.0%–100.0%	0.1%	10.0%	☆
A3-23	Setting of min. output speed in pressure control	0.0%–100.0%	0.1%	60.0%	☆
A3-24	Output delay time in pressure control	0.000–10.000s	0.001s	0.100s	☆
A3-25	Reference oil pressure S filter time	0.000–10.000s	0.001s	0.030s	☆
A3-26 to A3-31	Reserved	-	-	-	☆
A3-32	Min. slave input	0.0%–A3-34	0.1%	0.0%	☆
A3-33	Min. slave input frequency	-100.0%–100.0%	0.1%	0.0%	☆
A3-34	Medium slave input	A3-32–A3-36	0.1%	0.0%	☆
A3-35	Medium slave input frequency	-100.0%–100.0%	0.1%	0.0%	☆
A3-36	Max. slave input	A3-34–100.0%	0.1%	100.0%	☆
A3-37	Max. slave input frequency	-100.0%–100.0%	0.1%	100.0%	☆
Group A4					
A4-00	Rotational speed filter time	0–5.000s	0.001s	0.005s	
A4-01	Current filter time	0–5.000s	0.001s	0.010s	
A4-02	Reserved	-	-	-	-
A4-03	Overshoot restraining factor 1	20–500	1	100	
A4-04	Overshoot restraining factor 2	20–500	1	100	
Group F0: Basic Functions					
F0-00	Model display	1: G type (heavy load) 2: Reserved	1	Model dependent	●
F0-01	Control mode	0: Reserved 1: Speed sensor vector control (VC) 2: V/F control	1	1	★

Function Code	Name	Setting Range	Min. Unit	Default	Property
F0-02	Command source selection	0: Operation panel (LED indicator off) 1: Terminal input (LED indicator on) 2: Via serial port (LED indicator blinking)	1	0	☆
F0-03	Main frequency source X selection	0: Digital setting (preset frequency F0-08, you can make modification via UP/DOWN, non-retentive at power failure) 1: Digital setting (preset frequency F0-08, you can make modification via UP/DOWN, retentive at power failure) 2: AI1 3: AI2 4: AI3 5: Reserved 6: Multi-speed 7: Reserved 8: Reserved 9: Via communication	1	1	★
F0-04	Auxiliary frequency source Y selection	0: Digital setting (preset frequency F0-08, you can make modification via UP/DOWN, non-retentive at power failure) 1: Digital setting (preset frequency F0-08, you can make modification via UP/DOWN, retentive at power failure) 2: AI1 3: AI2 4: AI3 5: Reserved 6: Multi-speed 7: Reserved 8: Reserved 9: Via communication	1	0	★
F0-05	Auxiliary frequency Y relative value selection	0: Relative to maximum frequency 1: Relative to main frequency X	1	0	☆
F0-06	Auxiliary frequency Y range	0%–100%	1%	100%	☆

Function Code	Name	Setting Range	Min. Unit	Default	Property
F0-07	Frequency source selection	0: Main frequency source X 1: X and Y operation 2: Switchover between X and Y 3: Switchover between X and "X and Y operation" 4: Switchover between Y and "X and Y operation"	1	0	☆
F0-08	Preset frequency	0.00-maximum frequency (F0-10)	0.01 Hz	50.00 Hz	☆
F0-09	Rotating direction	0: Directions are the same. 1: Directions are reverse.	1	0	☆
F0-10	Maximum frequency	50.00–600.00 Hz	1	200.00 Hz	★
F0-11	Source of upper limit of output frequency	0: Set by F0-12 1: AI1 2: AI2 3: AI3 4: Reserved 5: Via communication	1	0	★
F0-12	Upper limit of output frequency	Frequency lower limit (F0-14) to maximum frequency (F0-10)	0.01 Hz	200.00 Hz	☆
F0-13	Upper limit offset	0.00Hz to maximum frequency (F0-10)	0.01 Hz	0.00 Hz	☆
F0-14	Lower limit of output frequency	0.00Hz to upper limit of output frequency (F0-12)	0.01 Hz	0.00 Hz	☆
F0-15	Carrier frequency	0.5–16.0 kHz	0.1 kHz	Model dependent	☆
F0-16	Carrier frequency adjustment selection	0: Fixed PWM, carrier frequency temperature adjustment invalid 1: Random PWM, carrier frequency temperature adjustment invalid 2: Fixed PWM, carrier frequency temperature adjustment valid 3: Random PWM, carrier frequency temperature adjustment valid	1	2	☆
F0-17	Acceleration time 1	0.0–6500.0s	0.1s	20.0s	☆
F0-18	Deceleration time 1	0.0–6500.0s	0.1s	20.0s	☆
Group F1: Motor Parameters					

Function Code	Name	Setting Range	Min. Unit	Default	Property
F1-00	Motor type selection	0: Common asynchronous motor 1: Variable frequency asynchronous motor 2: PMSM	1	2	★
F1-01	Rated power	0.4–1000.0kW	0.1 kW	Model dependent	★
F1-02	Rated voltage	0–440 V	1 V	Model dependent	★
F1-03	Rated current	0.01–655.35 A	0.01 A	Model dependent	★
F1-04	Rated frequency	0.00–max. frequency	0.01 Hz	Model dependent	★
F1-05	Rated rotational speed	0–30000 rpm	1 rpm	Model dependent	★
F1-06 to F1-10	Reserved	-	-	-	☆
F1-11	Shaft D inductance	0–65535	1	Model dependent	★
F1-12	Shaft Q inductance	0–65535	1	Model dependent	★
F1-13	Stator resistance	0–65535	1	Model dependent	★
F1-14	Unit	00–12	01	Model dependent	★
F1-15	Counter EMF	0–65535 V	1	Model dependent	★
F1-16	Tuning selection	0: No operation 1: Static tuning (low speed) 2: Dynamic tuning (hi-speed) 3: Tuning method 3	1	0	★
Group F2: Vector Control Parameters					
F2-00	Speed loop proportional gain1	0–100	1	60	☆
F2-01	Speed loop integration time 1	0.01–10.00s	0.01s	0.30s	☆
F2-02	Switchover frequency 1	0.00–F2-05	0.01 Hz	5.00 Hz	☆
F2-03	Speed loop proportional gain 2	0–100	1	60	☆
F2-04	Speed loop integration time 2	0.01–10.00s	0.01s	0.30s	☆

Function Code	Name	Setting Range	Min. Unit	Default	Property
F2-05	Switchover frequency 2	F2-02–max. frequency	0.01 Hz	10.00 Hz	☆
F2-06	Slip compensation coefficient	50%–200%	1%	100%	☆
F2-07	Time constant of speed loop filter	0.000–0.100s	0.001s	0.000s	☆
F2-08	Torque control	0: Invalid 1: Valid	1	0	☆
F2-09	Torque upper limit source	0: F2-10 1: AI1 2: AI2 3: AI3 4: Reserved 5: Via communication Analog input corresponding to F2-10.	1	0	☆
F2-10	Torque upper limit	0.0%–250.0%	0.1%	200.0%	☆
F2-11	Encoder PPR	1–65535	1	1024	★
F2-12	Reserved	-	-	-	★
F2-13	D shaft current loop Kp	0–65535	1	50	★
F2-14	D shaft current loop Ki	0–65535	1	50	★
F2-15	Q shaft current loop Kp	0–65535	1	50	★
F2-16	Q shaft current loop Ki	0–65535	1	50	★
F2-17	SoftPwm selection	0: Invalid 1: Valid	1	0	☆
Group F3: V/F Control Parameters					
F3-00	V/F curve setting	0: Linear V/F 1: Multi-point V/F 2: Square V/F	1	0	★
F3-01	Torque boost	0.0: Automatic 0.1%–30.0%	0.1%	1.0%	☆
F3-02	Cutoff frequency of torque boost	0.00 Hz–max. frequency	0.01 Hz	50.00 Hz	★
F3-03	V/F frequency 1	0.00 Hz–rated motor frequency	0.01 Hz	0.00 Hz	★
F3-04	V/F voltage 1	0.0%–100.0%	0.1%	0.0%	★
F3-05	V/F frequency 2	0.00–rated motor frequency	0.01 Hz	0.00 Hz	★

Function Code	Name	Setting Range	Min. Unit	Default	Property
F3-06	V/F voltage 2	0.0%–100.0%	0.1%	0.0%	★
F3-07	V/F frequency 3	0.00 Hz–rated motor frequency	0.01 Hz	0.00 Hz	★
F3-08	V/F voltage 3	0.0%–100.0%	0.1%	0.0%	★
F3-09	V/F slip compensation gain	0.0%–200.0%	0.1%	0.0%	☆
F3-10	AVR selection	0: Invalid 1: Valid in the whole process 2: Invalid only during deceleration	1	2	☆
F3-11	V/F oscillation suppression gain	0–100	1	Model dependent	☆
Group F4: Input Terminals					
F4-00	DI1 function selection	0: No function 1: Forward RUN (FWD, pump enabled) 2: Reverse RUN (REV) 3: Three-wire control 4: Forward JOG (FJOG) 5: Reverse JOG (RJOG) 6: Terminal UP 7: Terminal DOWN 8: Coast to stop 9: Fault reset (RESET) 10: RUN pause 11: External fault NO input 12: Multi-speed terminal 1 13: Multi-speed terminal 2 14: Multi-speed terminal 3 15: Multi-speed terminal 4 16: Acceleration/Deceleration time selection terminal 1 17: Acceleration/Deceleration time selection terminal 2	1	1	★
F4-01	DI2 function selection		1	0	★
F4-02	DI3 function selection		1	9	★
F4-03	DI4 function selection		1	0	★

Function Code	Name	Setting Range	Min. Unit	Default	Property
F4-04	DI5 function selection	18: Frequency source switchover 19: UP and DOWN setting clear (terminal, operation panel) 20: RUN command switching terminal 21: Acceleration/Deceleration prohibited	1	0	★
F4-05 to F4-14	Reserved	22-31: Reserved 32: DC braking command 33: External fault normally closed input 34: Frequency setting enabled If it is not set, it is valid by default. When modifying frequency, it controls the modification effective moment. 35: Reserved 36: External STOP terminal In operation panel control, it is used to stop the drive, equivalent to the STOP key on the operation panel. 37: Control command switchover terminal 2 It is used to perform switchover between terminal control and COM control. 38: Reserved 39: Switchover between main frequency source X and preset frequency 40: Switchover between auxiliary frequency source Y and preset frequency; 41-47: Reserved 48: Servo pump PID selection terminal 1 49: Servo pump PID selection terminal 2 50: CAN COM enabled	Reserved	Reserved	★
F4-15	DI filter time	1-10	1	4	☆
F4-16	Terminal command mode	0: Two-line 1 1: Two-line 2 2: Three-line 1 3: Three-line 2	1	0	★

Function Code	Name	Setting Range	Min. Unit	Default	Property
F4-17	Terminal UP/ DOWN rate	0.01–100.00 Hz/s	0.01 Hz/s	1.00 Hz/s	☆
F4-18	AI1 minimum input	-11.00–11.00 V	0.01 V	0.02 V	☆
F4-19	AI1 minimum input frequency	-100.0%–100.0%	0.1%	0.0%	☆
F4-20	AI1 maximum input	-11.00–11.00 V	0.01 V	10.00 V	☆
F4-21	AI1 maximum input frequency	-100.0%–100.0%	0.1%	100.0%	☆
F4-22	AI1 filter time	0.000–10.000s	0.001s	0.010s	☆
F4-23	AI2 minimum input	-11.00–11.00 V	0.01 V	0.02 V	
F4-24	AI2 minimum input frequency	-100.0%–100.0%	0.1%	0.0%	☆
F4-25	AI2 maximum input	-11.00–11.00 V	0.01 V	10.00 V	☆
F4-26	AI2 maximum input frequency	-100.0%–100.0%	0.1%	100.0%	☆
F4-27	AI2 filter time	0.000–10.000s	0.001s	0.005s	☆
F4-28	AI3 minimum input	-11.00–11.00 V	0.01 V	0.02 V	☆
F4-29	AI3 minimum input frequency	-100.0%–100.0%	0.1%	0.0%	☆
F4-30	AI3 maximum input	-11.00–11.00 V	0.01 V	10.00 V	☆
F4-31	AI3 maximum input frequency	-100.0%–100.0%	0.1%	100.0%	☆
F4-32	AI3 filter time	0.000–10.000s	0.001s	0.000s	☆
F4-33 to F4-42	Reserved	Reserved	Reserved	Reserved	☆
F4-43	AI1 sampling voltage 1	-9.999–9.999 V	0.001 V	2.000 V	☆
F4-44	AI1 corrected voltage 1	-9.999–9.999 V	0.001 V	2.000 V	☆
F4-45	AI1 sampling voltage 2	-9.999–9.999 V	0.001 V	8.000 V	☆
F4-46	AI1 corrected voltage 2	-9.999–9.999 V	0.001 V	8.000 V	☆
F4-47	AI2 sampling voltage 1	-9.999–9.999 V	0.001 V	2.000 V	☆
F4-48	AI2 corrected voltage 1	-9.999–9.999 V	0.001 V	2.000 V	☆

Function Code	Name	Setting Range	Min. Unit	Default	Property
F4-49	AI2 sampling voltage 2	-9.999~9.999 V	0.001 V	8.000 V	☆
F4-50	AI2 corrected voltage 2	-9.999~9.999 V	0.001 V	8.000 V	☆
F4-51	AI3 sampling voltage 1	-9.999~9.999 V	0.001 V	2.000 V	☆
F4-52	AI3 corrected voltage 1	-9.999~9.999 V	0.001 V	2.000 V	☆
F4-53	AI3 sampling voltage 2	-9.999~9.999 V	0.001 V	8.000 V	☆
F4-54	AI3 corrected voltage 2	-9.999~9.999 V	0.001 V	8.000 V	☆
F4-55 to F4-58	Reserved	-	-		☆
Group F5: Output Terminals					
F5-00	Reserved	Reserved	Reserved	Reserved	☆
F5-01	Control board relay (T/A1-T/B1-T/C1) output selection	0: No output 1: Servo drive running 2: Fault output	1	2	☆
F5-02	Control board relay (T/A2-T/C2) output selection	3: Frequency-level detection FDT output 4: Frequency reaching 5: Running at zero speed	1	1	☆
F5-03	Control board relay (T/A3-T/C3) output selection	6: Motor overload warning 7: Servo drive overload warning 8-11: Reserved 12: Running time reaching 13: Frequency restricted 14: Torque restricted 15: Ready to RUN 16: AI1>AI2 17: Frequency upper limit reaching 18: Frequency lower limit reaching 19: Under-voltage status output 20: Communication setting 21-22: Reserved 23: Double-discharge plunger pump sloping switchover (NO) 24: Output NC in pressure control 25: Slave pump alarms	1	0	☆

Function Code	Name	Setting Range	Min. Unit	Default	Property
F5-04 to F5-09	Reserved	-	-	-	☆
F5-10	AO1 output selection	0: Running frequency 1: Set frequency 2: Output current 3: Output torque 4: Output power 5: Output voltage 6: Reserved 7: AI1 8: AI2 9: AI3 10: Feedback frequency	1	10	☆
F5-11	AO2 output selection	11: Feedback pressure 12-16: Reserved		11	☆
F5-12, F5-13	Reserved	-	-	-	☆
F5-14	AO1 offset coefficient	-100.0%~100.0%	0.1%	0.0%	☆
F5-15	AO1 gain	-10.00~10.00	0.01	1.00	☆
F5-16	AO2 offset coefficient	-100.0%~100.0%	0.1%	0.0%	☆
F5-17	AO2 gain	-10.00~10.00	0.01	1.00	☆
F5-18 to F5-22	Reserved	-	-	-	☆
Group F6: Start/Stop Control Parameters					
F6-00	Startup mode	0: Direct start 1: Rotation speed tracking restart	1	0	☆
F6-01	Rotation speed tracking mode	0: From stop frequency 1: From zero speed 2: From maximum frequency	1	0	☆
F6-02	Rotation speed tracking speed	1~100	1	20	☆
F6-03	Startup frequency	0.00~10.00 Hz	0.01 Hz	0.00 Hz	★
F6-04	Startup frequency holding time	0.0s~36.0s	0.1s	0.0s	★
F6-05	Startup braking current	0%~100%	1%	0%	★
F6-06	Startup braking time	0.0s~36.0s	0.1s	0.0s	★

Function Code	Name	Setting Range	Min. Unit	Default	Property
F6-07	Acceleration/ Deceleration mode	0: Linear acceleration/ deceleration 1: S-curve acceleration/ deceleration	1	0	★
F6-08	Time proportion of S-curve start segment	0.0%–40.0%	0.1%	30.0%	★
F6-09	Time proportion of S-curve end segment	0.0%–40.0%	0.1%	30.0%	★
F6-10	Stop mode	0: Decelerate to stop 1: Coast to stop	1	0	☆
F6-11	DC braking starting frequency at stop	0.00 Hz–maximum frequency	0.01 Hz	0.00 Hz	☆
F6-12	DC braking waiting time at stop	0.0–36.0s	0.1s	0.0s	☆
F6-13	DC braking current at stop	0%–100%	1%	0%	☆
F6-14	DC braking time at stop	0.0–36.0s	0.1s	0.0s	☆
F6-15	Brake use ratio	0%–100%	1%	100%	☆
Group F7: Operation Panel and Display Parameters					
F7-00	LCD language selection	0: Chinese 1: English	1	0	☆
F7-01	MF.K Key function selection	0: MF.K key invalid 1: Switchover between operation panel and remote command channel (terminal or communication) 2: Switchover between forward rotation and reverse rotation 3: Forward JOG 4: Reverse JOG	1	0	★
F7-02	STOP/RESET key function	0: Valid only in operation panel control 1: Stop function of the STOP key valid in terminal control 2: Reset function of the STOP key valid in terminal control 3: Both stop and reset functions of the STOP key valid in terminal control	1	2	☆

Function Code	Name	Setting Range	Min. Unit	Default	Property
F7-03	QUICK parameter locking	0: Invalid 1: Valid	1	1	☆
F7-04	LED displaying running parameters	0–65535	1	624	☆
F7-05	LED displaying stop parameters	1–65535	1	1139	☆
F7-06	Load speed display coefficient	0.0001–6.5000	0.0001	1.0000	☆
F7-07	Heat sink temperature 1	0.0°C–100°C	1°C	-	●
F7-08	Heat sink temperature 2	0.0°C–100°C	1°C	-	●
F7-09	Accumulative running time	0–65535 h	1	-	●
F7-10	Software version No.1	-	-	-	●
F7-11	Software version No.2	-	-	-	●
Group F8: Auxiliary Functions					
F8-00	JOG running frequency	0.00 Hz–max. frequency	0.01 Hz	2.00 Hz	☆
F8-01	JOG acceleration time	0.0s–6500.0s	0.1s	20.0s	☆
F8-02	JOG deceleration time	0.0s–6500.0s	0.1s	20.0s	☆
F8-03	Acceleration time 2	0.0s–6500.0s	0.1s	20.0s	☆
F8-04	Deceleration time 2	0.0s–6500.0s	0.1s	20.0s	☆
F8-05	Acceleration time 3	0.0s–6500.0s	0.1s	20.0s	☆
F8-06	Deceleration time 3	0.0s–6500.0s	0.1s	20.0s	☆
F8-07	Acceleration time 4	0.0s–6500.0s	0.1s	20.0s	☆
F8-08	Deceleration time 4	0.0s–6500.0s	0.1s	20.0s	☆
F8-09	Jump frequency 1	0.00 Hz–max. frequency	0.01 Hz	0.00 Hz	☆
F8-10	Jump frequency 2	0.00 Hz–max. frequency	0.01 Hz	0.00 Hz	☆
F8-11	Frequency jump amplitude	0.00 Hz–max. frequency	0.01 Hz	0.00 Hz	☆
F8-12	FWD/REV dead-zone time	0.0s–3000.0s	0.1s	0.0s	☆
F8-13	REV control	0: Enabled 1: Disabled	1	0	☆

Function Code	Name	Setting Range	Min. Unit	Default	Property
F8-14	Action selection when set frequency below frequency lower limit	0: Run at frequency lower limit 1: Stop 2: Run at zero speed	1	0	☆
F8-15	Droop control	0.00–10.00 Hz	0.01 Hz	0.00 Hz	☆
F8-16	Overmodulation	0: Disabled 1: Enabled	1	0	☆
F8-17	Set accumulative running time	0–65000 h	1 h	65000 h	☆
F8-18	Startup protection selection	0: Not protected 1: Protected	1	0	☆
F8-19	Frequency detection value (FDT)	0.00 Hz–max. frequency	0.01 Hz	50.00 Hz	☆
F8-20	Frequency detection hysteresis (FDT hysteresis)	0.0%–100.0% (FDT level)	0.1%	5.0%	☆
F8-21	Frequency reaching detection amplitude	0.00–100% (max. frequency)	0.1%	0.0%	☆
F8-22	Detection of short-circuit to earth protection upon power-on	0: Disabled 1: Enabled	1	1	☆
F8-23	Action selection when the running time is reached	0: Continue to run 1: Stop	1	0	☆
Group F9: Fault and Protection					
F9-00	Motor overload protection selection	0: Disabled 1: Enabled	1	1	☆
F9-01	Motor overload protection gain	0.20–10.00	0.01	1.00	☆
F9-02	Motor overload alarm coefficient	50%–100%	1%	80%	☆
F9-03	Over-voltage stall gain	0 (no stall overvoltage) –100	1	0	☆
F9-04	Over-voltage stall protective voltage	120%–150%	1%	130%	☆
F9-05	Over-current stall gain	0–100	1	20	☆

Function Code	Name	Setting Range	Min. Unit	Default	Property
F9-06	Over-current stall protective current	100%–200%	1%	150%	☆
F9-07	Power dip ride through	0: Disabled 1: Enabled	1	0	☆
F9-08	Frequency drop rate at power dip ride through	0.00 Hz/s–max. frequency/s	0.01 Hz/s	10.00 Hz/s	☆
F9-09	Fault auto reset times	0-3	1	0	☆
F9-10	Fault relay action selection during fault auto reset	0: Not act 1: Act	1	0	☆
F9-11	Fault auto reset time interval	0.1s–100.0s	0.1s	1.0s	☆
F9-12	Input phase loss protection selection	0: Disabled 1: Enabled	1	1	☆
F9-13	Output phase missing protection selection	0: Disabled 1: Enabled	1	1	☆
F9-14	Speed protection deviation	0.50–50.00 Hz	0.01 Hz	10.00 Hz	☆
F9-15	Speed deviation protection time	0.0s (protection disabled) 0.1s–20.0s	0.1	10.0s	☆
F9-16	Motor temp. protection selection	0: Disabled 1: Enabled	1	0	☆
F9-17	Motor temp. protection mode	0: DI signal input 1: AI input 2-3: Reserved	1	0	☆

Function Code	Name	Setting Range	Min. Unit	Default	Property
F9-18	1st fault type	0: No fault 1: Reserved 2: Acceleration over-current (Err02) 3: Deceleration over-current (Err03) 4: Constant over-current (Err04) 5: Acceleration over-voltage (Err05) 6: Deceleration over-voltage (Err06) 7: Constant over-voltage (Err07) 8: Reserved 9: Under-voltage (Err09) 10: Servo drive overloaded (Err10) 11: Motor overloaded (Err11) 12: Input phase loss (Err12)	-	-	●
F9-19	2nd fault type	13: Output phase loss (Err13) 14: Heatsink overheat (Err14) 15: External fault (Err15) 16: COM fault (Err16) 17: Contactor fault (Err17) 18: Current detection fault (Err18) 19: Motor tuning fault (Err19) 20: Encoder/PG card fault (Err20) 21: Data overflow (Err21)	-	-	●
F9-20	Latest fault type	22: Reserved 23: Short circuit to ground (Err23) 24-41: Reserved 42: CAN COM fault (Err42) 43: Encoder fault (Err43) 44: Speed deviation protection fault (Err44) 45: Motor temp. fault (Err45) 46: Oil pressure sensor fault (Err46) 47-48: Multi-pump parallel run fault (Err47, Err48)	-	-	●
Group FA: Reserved					

Function Code	Name	Setting Range	Min. Unit	Default	Property
Group FB: Reserved					
Group FC: Multi-point AI Correction Parameters					
FC-00	Multi-point AI enabled bit	0–3	1	0	☆
FC-01	Multi-point AI1 min. input	-11.00–11.00 V	0.01 V	0.02 V	☆
FC-02	Multi-point AI1 min. input frequency	-100.0%–100.0%	0.1%	0.0%	☆
FC-03	Multi-point AI1 inflexion point 1 input	-11.00–11.00 V	0.01 V	1.00 V	☆
FC-04	Multi-point AI1 inflexion point 1 input frequency	-100.0%–100.0%	0.1%	10.0%	☆
FC-05	Multi-point AI1 inflexion point 2 input	-11.00–11.00 V	0.01 V	2.00 V	☆
FC-06	Multi-point AI1 inflexion point 2 input frequency	-100.0%–100.0%	0.1%	20.0%	☆
FC-07	Multi-point AI1 inflexion point 3 input	-11.00–11.00 V	0.01 V	3.00 V	☆
FC-08	Multi-point AI1 inflexion point 3 input frequency	-100.0%–100.0%	0.1%	30.0%	☆
FC-09	Multi-point AI1 inflexion point 4 input	-11.00–11.00 V	0.01 V	4.00 V	☆
FC-10	Multi-point AI1 inflexion point 4 input frequency	-100.0%–100.0%	0.1%	40.0%	☆
FC-11	Multi-point AI1 inflexion point 5 input	-11.00–11.00 V	0.01 V	5.00 V	☆
FC-12	Multi-point AI1 inflexion point 5 input frequency	-100.0%–100.0%	0.1%	50.0%	☆
FC-13	Multi-point AI1 inflexion point 6 input	-11.00–11.00 V	0.01 V	6.00 V	☆
FC-14	Multi-point AI1 inflexion point 6 input frequency	-100.0%–100.0%	0.1%	60.0%	☆

Function Code	Name	Setting Range	Min. Unit	Default	Property
FC-15	Multi-point AI1 inflexion point 7 input	-11.00~11.00 V	0.01 V	7.00 V	☆
FC-16	Multi-point AI1 inflexion point 7 input frequency	-100.0%~100.0%	0.1%	70.0%	☆
FC-17	Multi-point AI1 inflexion point 8 input	-11.00~11.00 V	0.01 V	8.00 V	☆
FC-18	Multi-point AI1 inflexion point 8 input frequency	-100.0%~100.0%	0.1%	80.0%	☆
FC-19	Multi-point AI1 inflexion point 9 input	-11.00~11.00 V	0.01 V	9.00 V	☆
FC-20	Multi-point AI1 inflexion point 9 input frequency	-100.0%~100.0%	0.1%	90.0%	☆
FC-21	Multi-point AI1 inflexion point 10 input	-11.00~11.00 V	0.01 V	10.00 V	☆
FC-22	Multi-point AI1 inflexion point 10 input frequency	-100.0%~100.0%	0.1%	100.0%	☆
FC-23	Multi-point AI1 inflexion point 11 input	-11.00~11.00 V	0.01 V	10.00 V	☆
FC-24	Multi-point AI1 inflexion point 11 input frequency	-100.0%~100.0%	0.1%	100.0%	☆
FC-25	Multi-point AI1 inflexion point 12 input	-11.00~11.00 V	0.01 V	10.00 V	☆
FC-26	Multi-point AI1 inflexion point 12 input frequency	-100.0%~100.0%	0.1%	100.0%	☆
FC-27	Multi-point AI1 inflexion point 13 input	-11.00~11.00 V	0.01 V	10.00 V	☆
FC-28	Multi-point AI1 inflexion point 13 input frequency	-100.0%~100.0%	0.1%	100.0%	☆
FC-29	Multi-point AI1 inflexion point 14 input	-11.00~11.00 V	0.01 V	10.00 V	☆

Function Code	Name	Setting Range	Min. Unit	Default	Property
FC-30	Multi-point AI1 inflexion point 14 input frequency	-100.0%~100.0%	0.1%	100.0%	☆
FC-31	Multi-point AI1 inflexion point 15 input	-11.00~11.00 V	0.01 V	10.00 V	☆
FC-32	Multi-point AI1 inflexion point 15 input frequency	-100.0%~100.0%	0.1%	100.0%	☆
FC-33	Multi-point AI1 inflexion point 16 input	-11.00~11.00 V	0.01 V	10.00 V	☆
FC-34	Multi-point AI1 inflexion point 16 input frequency	-100.0%~100.0%	0.1%	100.0%	☆
FC-35	Multi-point AI1 inflexion point 17 input	-11.00~11.00 V	0.01 V	10.00 V	☆
FC-36	Multi-point AI1 inflexion point 17 input frequency	-100.0%~100.0%	0.1%	100.0%	☆
FC-37	Multi-point AI1 max. input	-11.00~11.00 V	0.01 V	10.00 V	☆
FC-38	Multi-point AI1 max. input frequency	-100.0%~100.0%	0.1%	100.0%	☆
FC-39	Multi-point AI2 min. input	-11.00~11.00 V	0.01 V	0.02 V	☆
FC-40	Multi-point AI2 min. input frequency	-100.0%~100.0%	0.1%	0.0%	☆
FC-41	Multi-point AI2 inflexion point 1 input	-11.00~11.00 V	0.01 V	1.00 V	☆
FC-42	Multi-point AI2 inflexion point 1 input frequency	-100.0%~100.0%	0.1%	10.0%	☆
FC-43	Multi-point AI2 inflexion point 2 input	-11.00~11.00 V	0.01 V	2.00 V	☆
FC-44	Multi-point AI2 inflexion point 2 input frequency	-100.0%~100.0%	0.1%	20.0%	☆
FC-45	Multi-point AI2 inflexion point 3 input	-11.00~11.00 V	0.01 V	3.00 V	☆

Function Code	Name	Setting Range	Min. Unit	Default	Property
FC-46	Multi-point AI2 inflexion point 3 input frequency	-100.0%~100.0%	0.1%	30.0%	☆
FC-47	Multi-point AI2 inflexion point 4 input	-11.00~11.00 V	0.01 V	4.00 V	☆
FC-48	Multi-point AI2 inflexion point 4 input frequency	-100.0~100.0%	0.1%	40.0%	☆
FC-49	Multi-point AI2 inflexion point 5 input	-11.00~11.00 V	0.01 V	5.00 V	☆
FC-50	Multi-point AI2 inflexion point 5 input frequency	-100.0%~100.0%	0.1%	50.0%	☆
FC-51	Multi-point AI2 inflexion point 6 input	-11.00~11.00 V	0.01 V	6.00 V	☆
FC-52	Multi-point AI2 inflexion point 6 input frequency	-100.0%~100.0%	0.1%	60.0%	☆
FC-53	Multi-point AI2 inflexion point 7 input	-11.00~11.00 V	0.01 V	7.00 V	☆

Function Code	Name	Setting Range	Min. Unit	Default	Property
FC-54	Multi-point AI2 inflexion point 7 input frequency	-100.0–100.0%	0.1%	70.0%	☆
FC-55	Multi-point AI2 inflexion point 8 input	-11.00–11.00 V	0.01 V	8.00 V	☆
FC-56	Multi-point AI2 inflexion point 8 input frequency	-100.0%–100.0%	0.1%	80.0%	☆
FC-57	Multi-point AI2 inflexion point 9 input	-11.00–11.00 V	0.01 V	9.00 V	☆
FC-58	Multi-point AI2 inflexion point 9 input frequency	-100.0%–100.0%	0.1%	90.0%	☆
FC-59	Multi-point AI2 inflexion point 10 input	-11.00–11.00 V	0.01 V	10.00 V	☆
FC-60	Multi-point AI2 inflexion point 10 input frequency	-100.0%–100.0%	0.1%	100.0%	☆
Group FD Serial Port Communication Parameters					
FD-00	Baud rate	0: 300 bps 1: 600 bps 2: 1200 bps 3: 2400 bps 4: 4800 bps 5: 9600 bps 6: 19200 bps 7: 38400 bps	1	5	☆
FD-01	Data format				☆
FD-02	Local address				☆
FD-03	Response delay				☆
FD-04	Time-out time				☆
FD-05	Communication Protocol	0: Standard Modbus protocol 1: Background oscilometer protocol	1	1	☆

Note

The LED display of reserved parameters is "-".

Appendix 2 Servo Motor Code Table

Servo Motor Model	Motor Code (FP-02)	Servo Motor Model	Motor Code (FP-02)
ISMG1-95C15CD-R131F	00615	ISMG1-55C15CD-R131X	00315
ISMG1-11D17CD-R131F	00617	ISMG1-62C17CD-R131X	00317
ISMG1-12D20CD-R131F	00620	ISMG1-75C20CD-R131X	00320
ISMG1-14D15CD-R131F	00915	ISMG1-75C15CD-R131X	00415
ISMG1-16D17CD-R131F	00917	ISMG1-85C17CD-R131X	00417
ISMG1-18D20CD-R131F	00920	ISMG1-11D20CD-R131X	00420
ISMG1-22D15CD-R131F	01315	ISMG1-11D15CD-R131X	00715
ISMG1-24D17CD-R131F	01317	ISMG1-12D17CD-R131X	00717
ISMG1-28D20CD-R131F	01320	ISMG1-15D20CD-R131X	00720
ISMG1-30D15CD-R131F	01915	ISMG1-13D15CD-R131X	00815
ISMG1-41D20CD-R131F	01920	ISMG1-18D20CD-R131X	00820
ISMG2-20D15CD-R131F	A1315	ISMG2-13D15CD-R131X	A0815
ISMG2-23D17CD-R131F	A1317	ISMG2-14D17CD-R131X	A0817
ISMG2-27D20CD-R131F	A1320	ISMG2-17D20CD-R131X	A0820
ISMG2-31D15CD-R131F	A2015	ISMG2-18D15CD-R131X	A1115
ISMG2-36D17CD-R131F	A2017	ISMG2-21D17CD-R131X	A1117
ISMG2-42D20CD-R131F	A2020	ISMG2-24D20CD-R131X	A1120
ISMG2-42D15CD-R131F	A2715	ISMG2-24D15CD-R131X	A1515
ISMG2-48D17CD-R131F	A2717	ISMG2-28D17CD-R131X	A1517
ISMG2-57D20CD-R131F	A2720	ISMG2-33D20CD-R131X	A1520
ISMG2-60D15CD-R131F	A3815	ISMG2-35D15CD-R131X	A2215
ISMG2-68D17CD-R131F	A3817	ISMG2-39D17CD-R131X	A2217
ISMG2-80D20CD-R131F	A3820	ISMG2-46D20CD-R131X	A2220
ISMG2-80D15CD-R131F	A5115	ISMG2-43D15CD-R131X	A2815
ISMG2-91D17CD-R131F	A5117	ISMG2-49D17CD-R131X	A2817
ISMG2-11E20CD-R131F	A5120	ISMG2-58D20CD-R131X	A2820

Appendix 3 Configuration Examples of Servo Pump System

Flow (L/min)	Pressure (kgf/cm ²)	Max. Rotational speed (rpm)	Pump Discharge (ml/min)	Servo Motor Model	Servo Drive Model
62	140	2200	28	ISMG1-12D20CD-R131F	IS300T020-C
69		2200	31.5	ISMG1-12D20CD-R131F	IS300T030-C
84		2100	40	ISMG1-16D17CD-R131F	IS300T030-C
100		2000	50	ISMG1-16D17CD-R131F	IS300T040-C
126		2000	63	ISMG1-24D17CD-R131F	IS300T050-C
144		1800	80	ISMG1-30D15CD-R131F	IS300T050-C
180		1800	100	ISMG1-30D15CD-R131F	IS300T070-C
225		1800	125	ISMG2-42D15CD-R131F	IS300T080-C
270		1800	150	ISMG2-42D15CD-R131F	IS300T080-C
315		1800	175	ISMG2-60D15CD-R131F	IS300T100-C
360		1800	200	ISMG2-60D15CD-R131F	IS300T140-C/ IS300T140-C-L
450		1800	250	ISMG2-80D15CD-R131F	IS300T140-C/ IS300T140-C-L
504		1800	280	ISMG2-80D15CD-R131F	IS300T170-C/ IS300T170-C-L
62		160	2200	28	ISMG1-12D20CD-R131F
69	2200		31.5	ISMG1-18D20CD-R131F	IS300T030-C
84	2100		40	ISMG1-16D17CD-R131F	IS300T035-C
100	2000		50	ISMG1-24D17CD-R131F	IS300T040-C
126	2000		63	ISMG1-24D17CD-R131F	IS300T050-C
144	1800		80	ISMG1-30D15CD-R131F	IS300T050-C
180	1800		100	ISMG2-42D15CD-R131F	IS300T070-C
225	1800		125	ISMG2-60D15CD-R131F	IS300T080-C
270	1800		150	ISMG2-60D15CD-R131F	IS300T100-C
315	1800		175	ISMG2-60D15CD-R131F	IS300T140-C/ IS300T140-C-L
360	1800		200	ISMG2-80D15CD-R131F	IS300T140-C/ IS300T140-C-L
450	1800		250	ISMG2-80D15CD-R131F	IS300T170-C/ IS300T170-C-L

Flow (L/min)	Pressure (kgf/cm ²)	Max. Rotational sped (rpm)	Pump Discharge (ml/min)	Servo Motor Model	Servo Drive Model
62	175	2200	28	ISMG1-12D20CD-R131F	IS300T030-C
69		2200	31.5	ISMG1-18D20CD-R131F	IS300T035-C
84		2100	40	ISMG1-16D17CD-R131F	IS300T040-C
100		2000	50	ISMG1-24D17CD-R131F	IS300T050-C
126		2000	63	ISMG1-24D17CD-R131F	IS300T050-C
144		1800	80	ISMG1-30D15CD-R131F	IS300T070-C
180		1800	100	ISMG2-42D15CD-R131F	IS300T080-C
225		1800	125	ISMG2-60D15CD-R131F	IS300T100-C
270		1800	150	ISMG2-60D15CD-R131F	IS300T100-C
315		1800	175	ISMG2-80D15CD-R131F	IS300T140-C/ IS300T140-C-L
360		1800	200	ISMG2-80D15CD-R131F	IS300T140-C/ IS300T140-C-L

Note

- The IS300 servo drives of IS300T070-C, IS300T140-C-L and above need to configure external braking unit. For details, see section 1.3.
 - The table in Appendix 3 shows just configuration examples. For any requirement on adjustment due to different product positioning, contact our marketing personnel.
-
-

 **Warranty Agreement**

The warranty period of the product is 18 months (refer to the barcode on the equipment body). During the warranty period, if the product fails or is damaged under the condition of normal use by following the instruction, Our Company will be responsible for free maintenance.

Within the warranty period, maintenance will be charged for the damages caused by the following reasons:

- a. The damage caused by improper use or repair/modification without prior permission;
- b. The damage caused by fire, flood, abnormal voltage, other disasters and second disaster;
- c. The hardware damage caused by dropping or transportation upon the procurement.
- d. The damage caused by the improper operation;
- e. The damage or failure caused by the trouble out of the equipment (e.g. external device)

If there is any failure or damage to the product, please correctly fill out the Product Warranty Card in detail.

The maintenance fee is charged according to the newly adjusted Maintenance Price List by our company.

In general, the warranty card will not be re-issued. Please keep the card and present it to the maintenance personnel when asking for maintenance.

If there is any problem during the service, please contact the agent of our company or our company directly.

This agreement shall be interpreted by Shenzhen Inovance Technology Co., Ltd.

Shenzhen Inovance Technology Co., Ltd.

Service Department

Address: Block E, Hongwei Industry Park, Liuxian Road, Baocheng No. 70 Zone, Bao'an District, Shenzhen

Service Hotline: 400-777-1260

P.C.: 518101

Website: www.inovance.cn



Product Warranty Card

Customer information	Add. of unit:	
	Name of unit: P.C.:	Contact person:
		Tel.:
Product information	Product model:	
	Body barcode (Attach here):	
	Name of agent:	
Failure information	(Maintenance time and content):	
	Maintenance personnel:	



Shenzhen Inovance Technology Co.,LTD.

Address: Building E, Hongwei Industry Park, Liuxian Road, Baocheng No. 70 Zone,
Bao'an District, Shenzhen 508101 P.R.China

Tel : (0755)2979 9595

Fax : (0755)2961 9897

Technical support : 400-777-1260

<http://www.inovance.cn>

efesotomasyon.com