

Foreword

IS300 series servo drive is a servo drive which is specially designed for drive permanent magnet synchronous servo motor (PMSM). IS300 series servo drive has a wide capacity range (the rated current is 5A to 300A) .It's able to provide not only servo pump control, but also the general functional requirements. And it is a high-power servo drive which is value-for-money in the present market.

This manual is a guide to the operations of IS300 series servo drive.

This manual provides the user with related precautions and instructions for the prototyping, installation, parameter setup, and on-site trial run, and routine repair and maintenance of servo drive. In order to use this series of drive correctly, please read this manual carefully prior to operation and keep it properly for future using. The supporting equipment customers shall distribute this manual together with the equipment to the final users.

Unpacking and inspection:

Please confirm carefully when unpacking the box:

- 1) If the model and drive rated values on the nameplate are the same as your order. The box contains the equipment, certificate of conformity, user manual and warranty card.
- 2) If the product is damaged during the transportation. If there is any omission or damage, please contact our company or the supplier immediately.

First time use:

The users who use this product for the first time shall read this manual carefully. For any doubt on certain functions and performances, please contact the technical support personnel of our company for help so as to use this product properly.

With commitment to the constant improvement of the servo drive, our company may change the information provided without additional notice.



IS300 series servo drive complies with the following international standards, and some products have passed the CE certification.

IEC/EN61800-5-1:2003 "Safety Regulations on Commissionable Electric Drive System" and IEC/EN 61800-3:2004 Commissionable Electric Drive System: The third Part: Electromagnetic Compatibility Standard and Specific Testing Method for the Product.

Contents

FOREWORD	- 1 -
CHAPTER 1 PRODUCT INFORMATION.....	- 5 -
1.1 IS300 Servo Drive Designation Rules.....	- 5 -
1.2 IS300 Servo Drive Series	- 6 -
1.3 IS300 Servo Drive Brake Components Prototyping Table	- 7 -
1.4 IS300 Servo Drive External Electrical Parts Table.....	- 8 -
1.5 Physical Appearance and Dimensions of Mounting Hole	- 9 -
CHAPTER 2 WIRING	- 12 -
2.1 Connection Mode.....	- 12 -
2.2 Main Circuit Terminals and Connections.....	- 13 -
2.3 Control Terminals and Connections.....	- 14 -
2.4 IS300 Servo Drive Jumper Function Description	- 17 -
2.5 Function Instructions of Servo Drive PG Card Terminals	- 18 -
CHAPTER 3 SERVO PUMP TRIAL RUN STEPS AND PROTOTYPING OF SERVO PUMP OPTIONAL PARTS.....	- 20 -
3.1 Servo Pump Trial run Process	- 20 -
3.2 Motor Trail Run	- 20 -
3.3 Servo Pump Application Trail Run	- 22 -
CHAPTER 4 FAILURE DIAGNOSIS AND SOLUTION.....	- 27 -
4.1 Failure Diagnosis and Solution	- 27 -
4.2 COMMON FAULT AND RESOLUTION.....	- 40 -
CHAPTER 5 ISMG SERVO DRIVE USING INSTRUCTION	- 44 -
5.1 ISMG SERVO DRIVE NAMING RULES.....	- 44 -
5.2 ISMG SERVO MOTOR PERFORMANCE PARAMETER.....	- 45 -
5.3 ISMG SERVO MOTOR PHYSICAL DIMENSION DIAGRAM	- 47 -
5.4 INSTRUCTIONS OF SUPPORTING BOARD OF ISMG SERVO MOTOR BASE INSTALLATION.....	- 49 -
5.5 ISMG SERVO MOTOR WIRING INSTRUCTIONS.....	- 49 -
APPENDIX 1: COMMON PARAMETERS TABLE	- 51 -
APPENDIX 2 SERVO MOTOR CODE TABLE	- 63 -



Product Information

Chapter 1 Product Information

1.1 IS300 Servo Drive Designation Rules

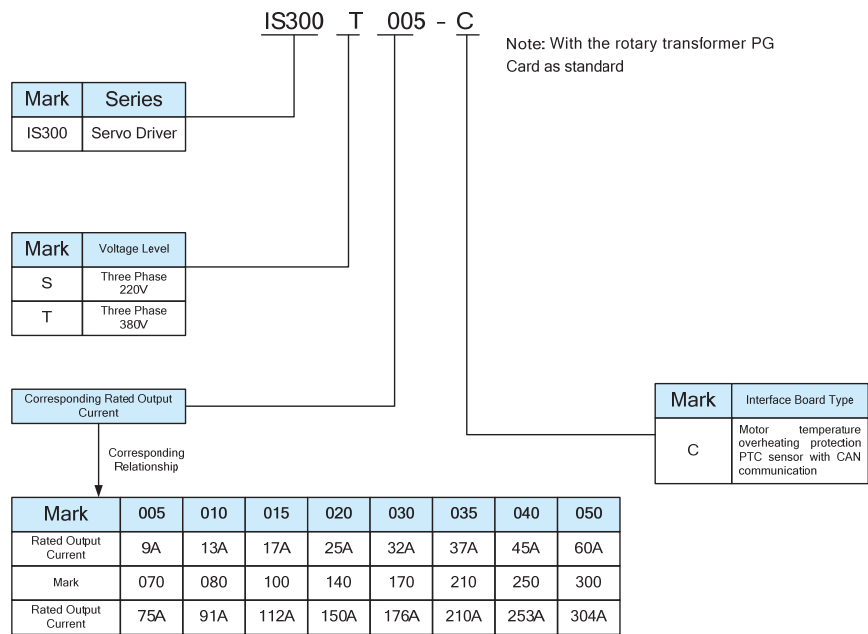

1.2 IS300 Servo Drive Series

Servo drive model	Input voltage	Power supply capacity (kVA)	Input current (A)	Output current (A)	System pressure of adaptable injection moulding Machine (kgf)	Maximum flow rate of adaptable injection moulding machine (L/min)
IS300T005	Three -phase 380V Range:- 15% to 20%	5.9	10.5	9.0	175	20
IS300T010		8.9	14.6	13.0		30
IS300T015		11.0	20.5	17.0		40
IS300T020		17.0	26.0	25.0		60
IS300T030		21.0	35.0	32.0		75
IS300T035		24.0	38.5	37.0		85
IS300T040		30.0	46.5	45.0		105
IS300T050		40.0	62.0	60.0		140
IS300T070		57.0	76.0	75.0		180
IS300T080		69.0	92.0	91.0		210
IS300T100		85.0	113.0	112.0		260
IS300T140		114.0	157.0	150.0		360
IS300T170		134.0	180.0	176.0		420
IS300T210		160.0	214.0	210.0		500
IS300T250		192.0	256.0	253.0		600
IS300T300		231.0	307.0	304.0		720

1.3 IS300 Servo Drive Brake Components Prototyping Table

Servo drive model	Recommended power of brake resistor	Recommended resistance value of brake resistor	Braking unit	Remarks
IS300T005	300W	$\geq 130\Omega$	Built-in as standard	No special specification
IS300T010	400W	$\geq 90\Omega$		
IS300T015	500W	$\geq 65\Omega$		
IS300T020	800W	$\geq 43\Omega$		
IS300T030	1000W	$\geq 32\Omega$		
IS300T035	1300W	$\geq 25\Omega$		
IS300T040	1500W	$\geq 22\Omega$		
IS300T050	2500W	$\geq 16\Omega$		
IS300T070	3.7 kW	$\geq 16\Omega$	Externally connected	MDBU-35-B
IS300T080	4.5 kW	$\geq 16\Omega$	Externally connected	MDBU-35-B
IS300T100	5.5 kW	$\geq 8\Omega$	Externally connected	MDBU-70-B
IS300T140	7.5 kW	$\geq 8\Omega$	Externally connected	MDBU-70-B
IS300T170	4.5 kWx2	$\geq 8\Omega \times 2$	Externally connected	MDBU-70-Bx2
IS300T210	5.5 kWx2	$\geq 8\Omega \times 2$	Externally connected	MDBU-70-Bx2
IS300T250	6.5 kWx2	$\geq 8\Omega \times 2$	Externally connected	MDBU-70-Bx2
IS300T300	16kW	$\geq 2.5\Omega$	Externally connected	MDBU-210-B

Note: x2 refers to two Braking units paralleled with their respective brake resistor; the meaning of x3 is the same with x2.

1.4 IS300 Servo Drive External Electrical Parts Table

Servo drive model	Circuit breaker (MCCB)	Recommended contactor	Recommended input filter A	Recommended conducting Wire of main circuit at the input side	Recommended conducting wire of main circuit at the output side	Recommended conducting wire of control circuit
	A	A	A	mm ²	mm ²	mm ²
IS300T005	25	16	25	4	4	1.5
IS300T010	32	25	35	4	4	1.5
IS300T015	40	32	35	4	4	1.5
IS300T020	63	40	50	4	4	1.5
IS300T030	63	40	50	6	6	1.5
IS300T035	100	63	80	6	6	1.5
IS300T040	100	63	80	10	10	1.5
IS300T050	125	100	100	16	10	1.5
IS300T070	160	100	120	16	16	1.5
IS300T080	200	125	150	25	25	1.5
IS300T100	200	125	150	35	25	1.5
IS300T140	250	160	200	50	35	1.5
IS300T170	250	160	200	70	35	1.5
IS300T210	350	350	250	120	120	1.5
IS300T250	400	400	300	150	150	1.5
IS300T300	500	400	400	185	185	1.5

1.5 Physical Appearance and Dimensions of Mounting Hole

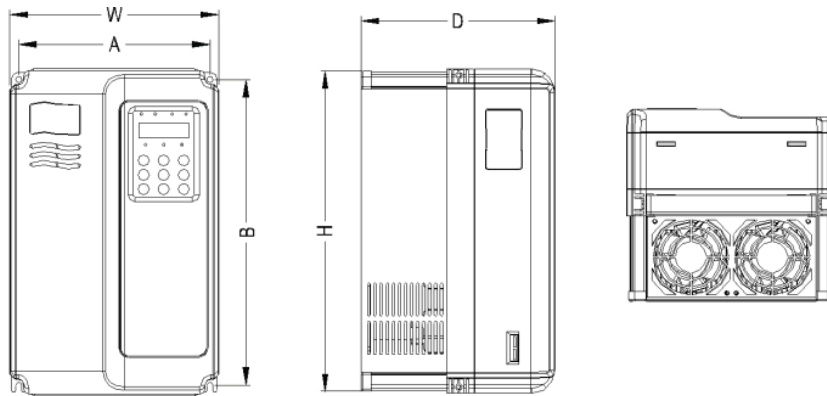

Schematic Diagram for Physical Dimensions and Mounting Hole Dimensions of IS300T005~IS300T030

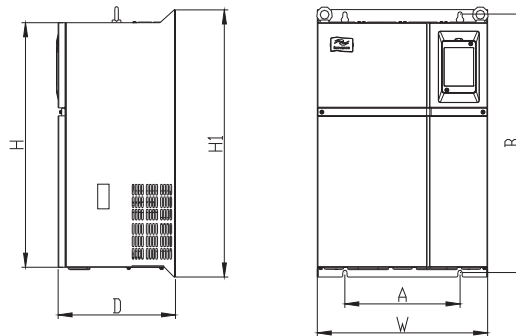

Schematic Diagram for Physical Dimensions and Mounting Hole Dimensions of IS300T005~IS300T030

Model	Mounting hole		Physical dimensions				Diameter of mounting hole	Weight (kg)
	A	B	H	H1	W	D		
IS300T005	148	236	248	/	160	183	φ5	2.5
IS300T010								
IS300T015	190	305	322	/	208	192	φ6	6.5
IS300T020								
IS300T030								
IS300T035	235	447	432	463	285	228	Φ8	20
IS300T040								
IS300T050								
IS300T070	260	580	549	600	385	265	φ10	32
IS300T080								
IS300T100								
IS300T140	343	678	660	700	473	307	φ10	47
IS300T170								
IS300T210	449	905	880	930	579	375	φ10	90
IS300T250								
IS300T300								



Wiring

2.2 Main Circuit Terminals and Connections

Terminals	Name	Description
R、S、T R、S and T	Input terminal of three-phase power supply	AC single-phase 220V power connection point
(+)、(-)(+) and (-)	Negative and positive terminals of DC bus	Shared DC bus input point (connection point of external braking unit of above IS300T070 (included))
(+)、PB(+) and PB	Connecting terminal of brake resistor	Connection point of brake resistor of below IS300T050(included)
P、(+P and (+)	Connection terminal of external reactor	Connection point of external reactor above IS300T140(included)
U、V、W U、V and W	Output terminal of servo drive	Connect the three-phase motor
	Earth terminal	Earth terminal

















2.3 Control Terminals and Connections

Type	Terminal	Terminal name	Function description
power supply	+10V-GND	10V power supply	Provide 10V±10% power supply for external-units, and the maximum output current is 10mA. It is generally used as the operating power supply for the external potentiometer. The potentiometer resistance range is 1 kΩ to 5kΩ.
	+13V-GND	Pressure sensor power supply	Provide 13V±10% power supply for external units. The maximum output current is 10mA. It is generally used as the operating power supply for pressure sensor.
	+24V-COM	+24V power supply	Provide +24V power supply for external units. It is generally used as the operating power supply for digital input/output terminals. 24V±10%, no-load virtual voltage can not exceed 30V. The maximum output current is 200mA. It is internally insulated with GND.
	OP	External power input terminal	COM and 24V is internally insulated .Connect to 24V by default upon delivery. When external signal is used to drive DI1toDI5, OP needs to connect to the external power supply and disconnect from the +24V power terminal.(It is determined by the J7 jumper on the control board.)
Analog Input	AI1-GND	Analog input terminal 1 (default pressure setting)	1、 Input Voltage range: ±10V The resolution is 12 bit. The correction precision is 0.5%. 2、 Input resistance: 100kΩ.

Type	Terminal	Terminal name	Function description
	AI2-GND	Analog input terminal 2 (default flow setting)	1、 The resolution is 12 bit, the correction precision is 0.5 %. 2、 Input resistance: 100kΩ。
	AI3-GND	Analog input terminal 3 (default pressure sensor signal input)	1. Input range: ±10V/0 to 20mA, which is determined by J5 jumper on the control board. There is 12-bit resolution; the correction precision is 0.5 %. 2. Input impedance: It is 100kΩ at the time of voltage input and 500Ω at the time of current input.
Digital Input	DI1~ DI5-COM	Digital input 1	1、 Insulate drain-to-source input programmable terminals, input frequency is less than 100 Hz; 2、 Input resistance: 3.3kΩ 3、 Voltage range for level input: 9Vto 30V.
	PTCP-PTC N	Motor overheating protection input	Motor overheating protection PTC sensor, support PTC130、PTC150 etc.
Communication Terminal	CANH/ CANL/ CGND	CAN Communication terminal	The highest communication speed is 1Mbps.Whether to connect terminal resistance is determined by the J8 jumper on the control board.
	485B/ 485A	485 Communication terminal	Retain the terminal without the function by default, the highest communication speed is 230Kbps with isolation. Whether to connect terminal resistance is determined by the J9 jumper on the control board.

Type	Terminal	Terminal name	Function description
Analog Output	AO1-GND	Analog output 1	The voltage or current output is determined by the J4 jumper on the control board. Output range: 0V to 10V and 0mA to 20mA. There is 12-bit resolution. The correction precision is 1 %. The maximum load resistance value is not less than 500Ω.
	AO2-GND	Analog output 2	The voltage or current output is determined by the J6 jumper on the control board. Output range: 0V to 10V and 0mA to 20mA. There is 12-bit resolution. The correction precision is 1 %. The maximum load resistance value is not less than 500Ω.
Relay output	T/A1-T/B1	Normally closed terminal	Contact driving capacity: AC250V, 3A, COSφ=0.4。 DC 30V, 1A。
	T/A1~T/A3 3-T/C1~T/C3	Normally open terminal	
Auxiliary interface	CNR1	External keyboard interface	External keyboard and parameter copy unit interface

2.4 IS300 Servo Drive Jumper Function Description

Jumper number	Jumper position	Function description	Jumper position	Function description
J2		GND terminal connect-to-ground capacitance(Adopt when the drive connect-to-ground)		GND terminal connect-to-ground capacitance(Adopt when the drive connect-to-ground)
J3		GND terminal connect-to-ground capacitance(Adopt when the drive connect-to-ground)		GND terminal connect-to-ground capacitance(Adopt when the drive connect-to-ground)
J4		AO1 output in the form of voltage (DC0 to 10V)		AO1 output in the form of voltage (0 to 20mA)
J5		AI3 input in the form of voltage (DC-10 to +10V)		AI3 input in the form of voltage (0 to 20mA)
J6		AO2 output in the form of voltage (DC0 to 10V)		AO2 output in the form of current
J7		Internal power supply drives the input terminal DI1 to DI5		External power supply drives the input terminal DI1 ~ DI5
J8		CAN communication connect to terminal resistors, the terminal equipment adopt when multi-machine communications,.		CAN communication does not connect to terminal resistors, the middle equipment adopt when multi-machine communications.
J9		485 communication connect to the terminal resistors, the terminal equipment adopt when multi-machine communications,.		485 communication does not connect to the terminal resistors, the middle equipment adopt when multi-machine communications,.

Note: Jumper position indicates the position of connection terminals observation

2.5 Function Instructions of Servo Drive PG Card Terminals

Item	Name	Description
1	EXC	Excitation Signal
2	/EXC	
3	SIN	SIN Feedback Signal
4	SINLO	
5	COS	COS Feedback Signal
9	COSLO	
6	PTC-P	Motor overheating protection PTC sensor, support PTC130,PTC150 ,etc.
7	PTC-N	
8	--	--

Note: Description of Specialized signal Lines for IS300 Servo Drive (for reference)

Signal Definition	EXC-	EXC+	SIN+	SIN-	COS+	COS-	PTC+	PTC-
Color of Encoder Cable Line Specialized for IS300 Servo Drive	Red	Blue	Pink	Grey	Yellow	Green	White	Brown
Corresponding "MD38PG4" PG Card Pin	1	2	3	4	5	9	6	7

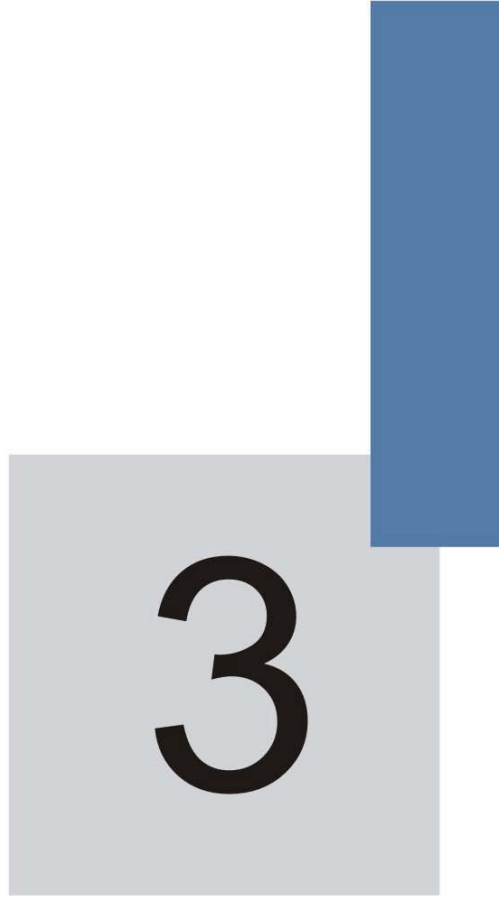

Mechanical and Electric Installation

Chapter 3 Servo Pump Trial Run Steps and Prototyping of Servo Pump Optional Parts

3.1 Servo Pump Trial run Process

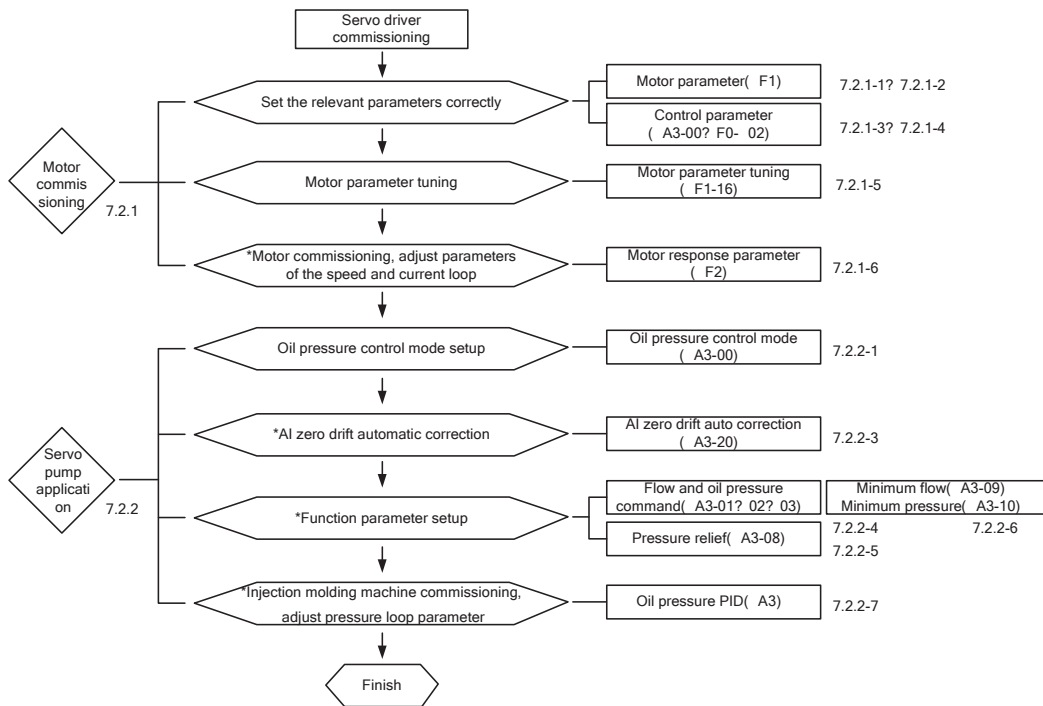

Note: (1) Detailed instructions please refer to the following corresponding contents.
 (2) Do not conduct the commissioning steps with *, it can also start the injection molding machine action.

3.2 Motor Trail Run

- 3.2.1 Set motor parameters of group F1 (F1-00 to F1-05, F1-15)
- 3.2.2 Set pole-pairs number of the rotary encoder
- 3.2.3 Set the drive to non-oil pressure control mode: A3-00 =“0”
- 3.2.4 Set the drive to operation panel control mode, at this time the light of LOCAL/REMOT is off.
- 3.2.5 Motor parameter tuning(automatic identification) (F1-16)

- a) F1-16="0": No operation. It doesn't conduct the motor parameters tuning.
- b) F1-16="1": Static tuning. Adopt when the motor back EMF is known. Run the motor at the low speed without opening the overflow valve during tuning.
- c) F1-16="2": Dynamic tuning. Adopt it when the motor back EMF is unknown. Run the motor at the high speed with opening the overflow valve during tuning. Carrier tuning will affect the precision of the motor parameters tuned, affecting the system control effectiveness.
 - a) If correctly set F1 group motor parameters (F1-00 to F1-05, F1-15) and the rotary encoder number of pole-pairs (A1-04), just only conduct F1-16="1" (static tuning).
 - b) If it is only able to correctly set F1 group motor parameters (F1-00 to F1-05), rotary encoder number of pole-pairs (A1-04) was unable to determine the F1-15 (back EMF), you must conduct F1-16="2" (dynamic tuning).

The numerical value of parameter F1-16 will restore to zero automatically after tuning.

If the drive alarm Err43 in the tuning process, it indicates that the encoder feedback signal is wrong, please check the encoder signal wiring and installation precision.

3.2.6 When at trial run, set running frequency (F0-08), run by using the operation panel, while detecting whether the output current is normal, whether the motor is running quietly, and the way of using the operator. Please refer to the operation and display of Chapter 4.

- a) Look into whether the running direction of the drive is correct, if it is correct, please swap motor wiring arbitrary two-phase UVW and recheck motor parameters tuning. Then trial run.
- b) If there is abnormal running, please check the motor parameters (F1 groups) and rotary encoder number of pole-pairs (A1-04) setup, and then restart the motor parameters tuning, then trial run.
- c) Motor has oscillation when running or sends a low voice, please weaken the speed loop (F2-00, F2-01, F2-03, F2-04) and current loop (F2-13, F2-14, F2-15, F2-16) appropriately (reduce the value of F2-00, F2-03, F2-13, F2-14, F2-15, F2-16, increase the value of F2-01, F2-04).
- d) Motor running speed is not steady, please enhance speed loop (F2-00, F2-01, F2-03, F2-04) and current loop (F2-13, F2-14, F2-15, F2-16) appropriately. (Increase the value of F2-00, F2-03,

F2-13、F2-14、F2-15、F2-16.Reduce the value of F2-01、F2-04)

NOTE: The slow response of the speed and current loop will affect the pressure stability directly, if the condition allows, please set the stronger speed loop and current loop response.

3.3 Servo Pump Application Trail Run

3.3.1 AI zero drift auto-correction (A3-20):

Note: Make sure that the drive runs at zero speed before AI zero drift auto-correction

F00-08= "0", start "RUN" signal. Please make sure F00-02= "0"

Set AI zero drift auto correction parameter A3-20 to 1, the drive will conduct an AI zero drift auto correct operation:

Write the detection value zero drift of three analog channel into the parameters, they are F4-18 (AI1 is the minimum input), F4-23 (AI2 is the minimum input), F4-28 (AI3 is the minimum input). The detection value of zero drift can be found at U1-07, U1-08, and U1-09.

3.3.2 Oil pressure control mode selection (A3-00) :

a)A3-00="0": Non- Oil pressure control mode

b)A3-00="1": Drive oil pressure control mode 1.CAN provides oil pressure command and flow command, AI3 analog Channel provides oil pressure feedback command, the drive conducts oil pressure control.

c)A3-00="2": Drive oil pressure control mode2. AI1 provide oil pressure command, AI2 analog channel provide flow command, AI3 analog Channel provides oil pressure feedback command, and the drive conducts oil pressure control.

d)A3-00="3": Oil pressure control mode (special use), the control parameters of group A3 servo pump control group are inactive.

e) A3-00="4": Reserved.

3.3.3 Auto-setup of the parameters in the oil pressure control mode

When the non-oil pressure mode switches to the oil pressure mode (A3-00≠"0") , the relevant parameters will be automatically set. See the following table for details.

Function Code	Function Code Description	Setup
F0-01	Control mode	1(Vector control mode)
F0-02	Command source	1(Terminal command source)

Function Code	Function Code Description	Setup
F0-03	Frequency source	If A3-00="2", F0-03="3 "(A I2 is frequency source).If A3-00 = "1" or "3", F0-03="9"(Communication setup is frequency source)
F0-07	Frequency source selection	0 (Non-auxiliary frequency source)
F0-17	Speed-up time	0.0s
F0-18	Speed-down time	0.0s
F1-00	Motor type selection	2 (Synchronous motor)
F4-00	DI1 terminal function selection	11 (Running enabled)
F4-01	DI2 terminal function selection	48 (Oil pressure control PID select terminal 1)
F4-02	DI3 input function selection	49(Oil pressure control PID select terminal 2)
F4-03	DI4 input function selection	9 (Fault reset)
F4-04	DI5 input function selection	50(CAN communication enabled)
F5-01	DO1 output function selection	2 (Fault output)
F5-02	DO2 output function selection	23(Double-displacement plunger pump swash plate switch (NO)
F5-03	DO3 output function selection	24 (Pressure control status output NC)

It may be power-failure recorded (the drive restore to be the setup value automatically while power-on again) when modify the above parameters in the oil pressure control mode, When the oil pressure mode switches to the non-oil pressure mode, the above parameters will be restored to switch to the numerical value which is before oil pressure control mode.

3.3.4 Command setup of flow and oil pressure (A3-01、A3-02、A3-03) :

- a)A3-01: Maximum rotation speed. Set the motor running maximum

rotation speed which is the motor rotation speed corresponds to flow command one hundred percent.

b)A3-02: System oil pressure. Set system maximum pressure.

c) A3-03: Maximum oil pressure. Set the pressure scale of pressure sensor.

3.3.5 Pressure relief setup (A3-08):

A3-08: It is the maximum reverse rotation speed when pressure relief, which corresponds to the percentage setup of maximum rotation speed. It is used to set the maximum reverse rotation speed. The greater setup value is, the faster pressure relief will be, but excessive noise cause pump reversal. The smaller setting value is, the slower pressure relief will be.

3.3.6 Minimum Flow and Minimum Pressure (A3-09、A3-10):

Due to oil pump exists internal leakage, the system is not given flow and pressure command, the hydraulic oil in oil circuit oil tanks will reflow to the oil tank, then it will cause the air enters the oil circuit, resulting in a system running noise and unstable. So you need to set a certain minimum Flow (A3-09, corresponding the percentage of maximum rotation speed setup) and minimum pressure (A3-10).

3.3.7 System response (Oil pressure PID control)

The drive provides four groups PID, according to the input terminals of the DI2 and DI3 combination selection, the corresponding selection is as follows.

Table 7-2 PID Combination Selection

DI3	DI2	Group PID
0	0	The first group PID: A3-05,A3-06,A3-07
0	1	The second group PID: A3-11,A3-12,A3-13
1	0	The third group PID: A3-14,A3-15,A3-16
1	1	The fourth group PID: A3-17,A3-18,A3-19

The greater proportional gain K_p is, the smaller integration time K_i will be, and the larger derivative time K_d is, the faster response will be. Response too quickly can easily lead to overshoot and cause system instability and running oscillation.

In contrast, the smaller proportional gain K_p is, the greater integration time K_i will be, and the smaller derivative time K_d is, the lower response will be. Response too slowly can easily lead to inefficient and products unstable.



Failure Diagnosis and Solution

Chapter 4 Failure Diagnosis and Solution

4.1 Failure Diagnosis and Solution

IS300 Servo Driver has 23 pieces of warning information and protection function. In case of abnormal fault, the protection function will be invoked, the driver will stop output, and the faulty relay contact of the driver will start, and the fault code will be displayed on the display panel of the driver. Before consulting the service department, the user can perform self-check according to the prompts of this chapter, analyze the fault cause and find out the solution. If the fault is caused by the reasons as described in the dotted frame, please consult the agents of driver or our company directly.

Err01 (Reserved)

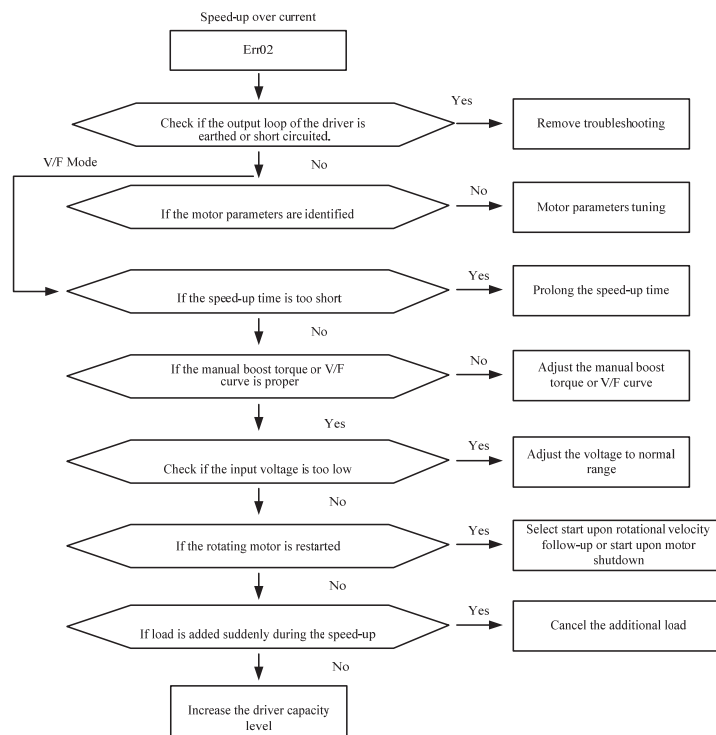

Speed-up over current (Err02)

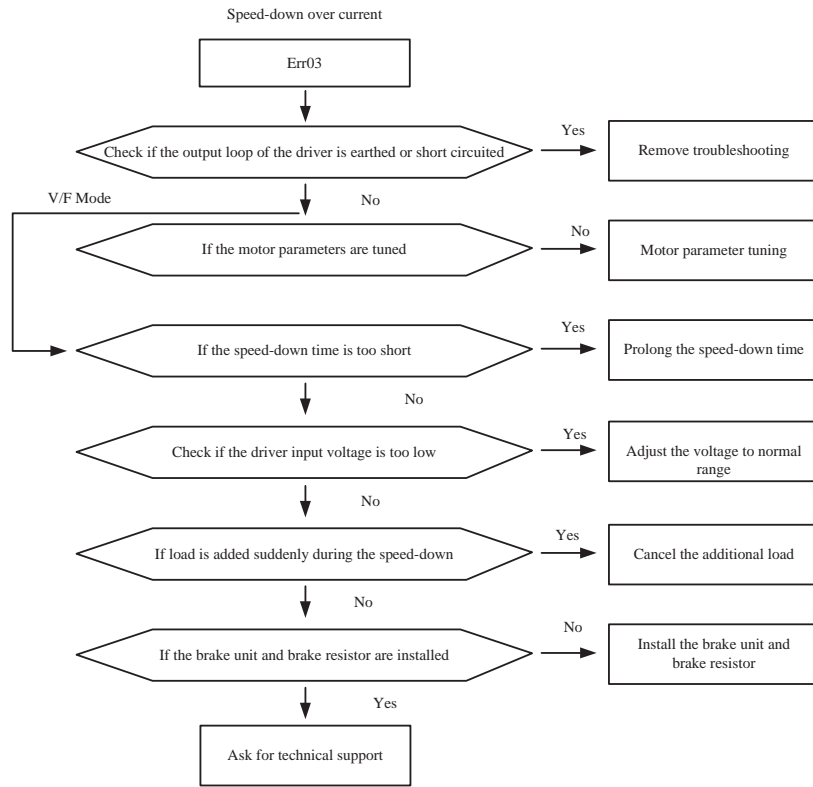

Speed-down over current (Err03)

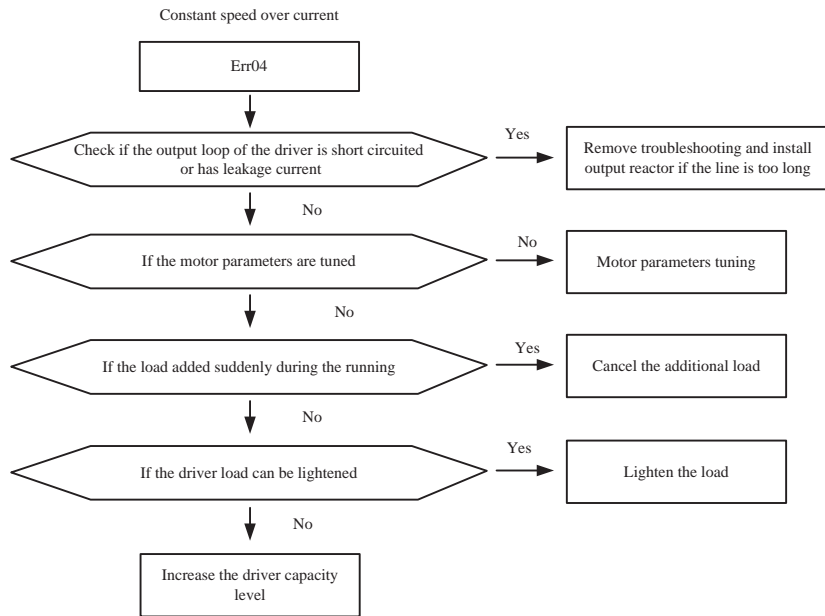

Constant speed over current (Err04)

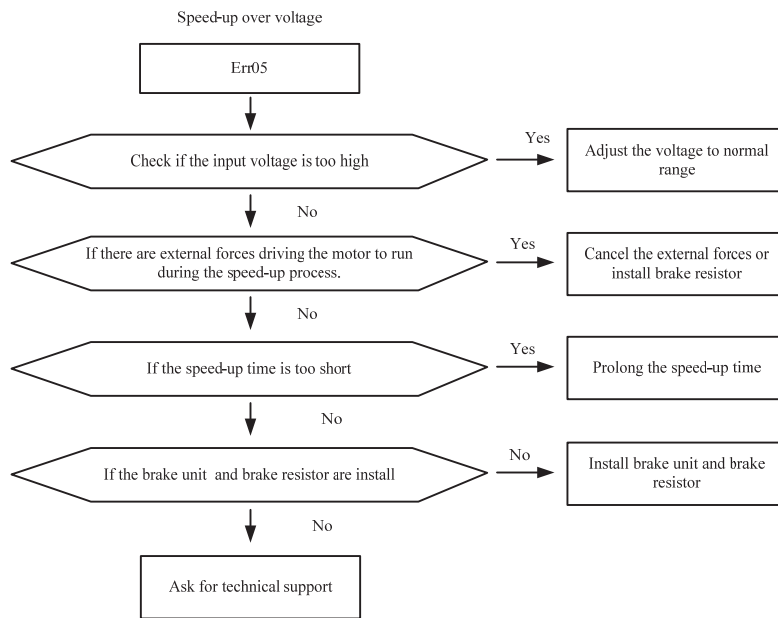

Speed-up over voltage (Err05)

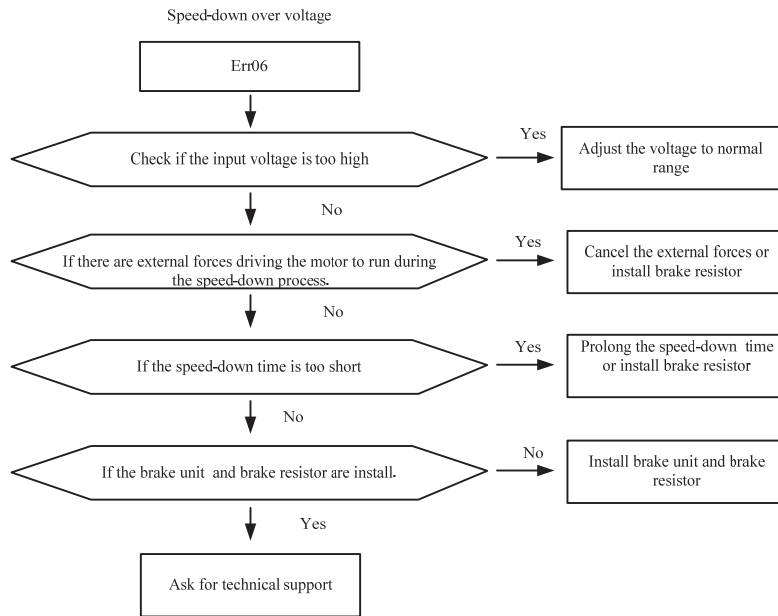

Speed-down over voltage (Err06)

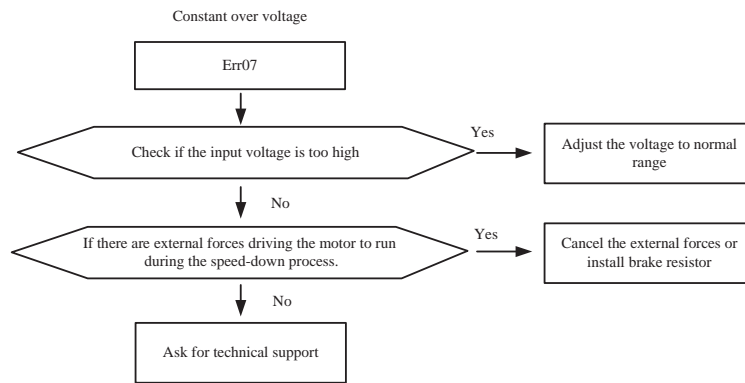

Constant Speed over voltage (Err07)

Err08 (Reserved)

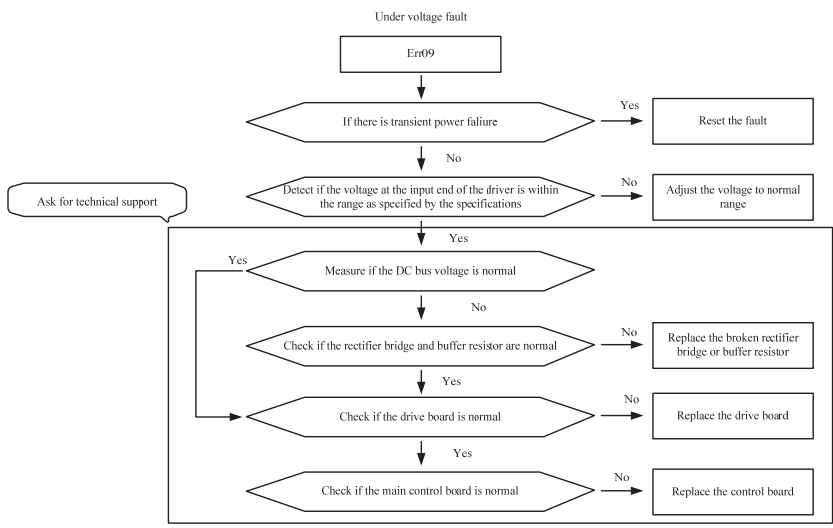

Under Voltage Fault (Err09)

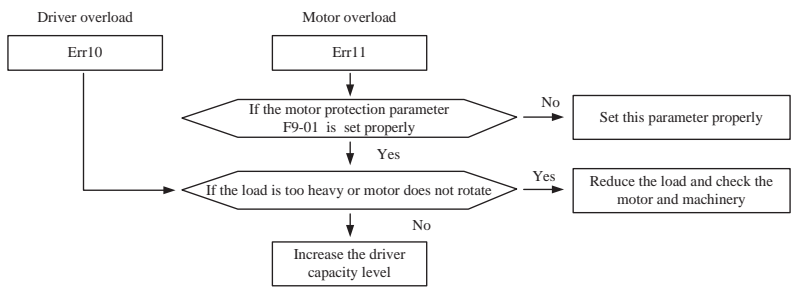

Servo Driver/Motor Overload (Err10/Err11)

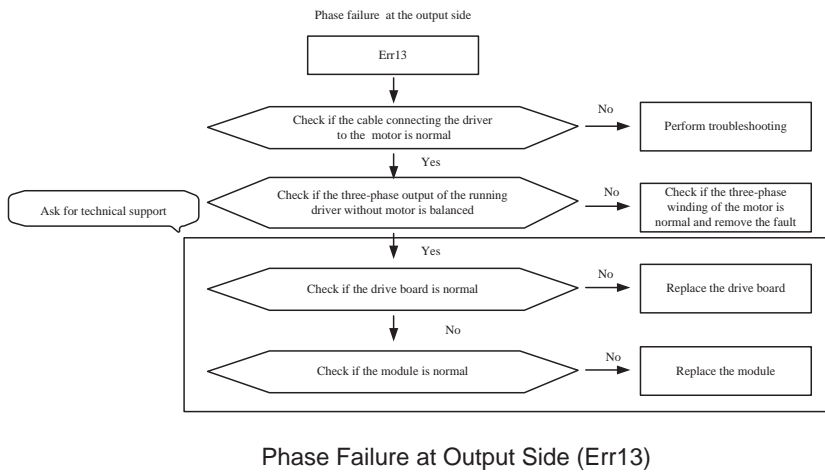
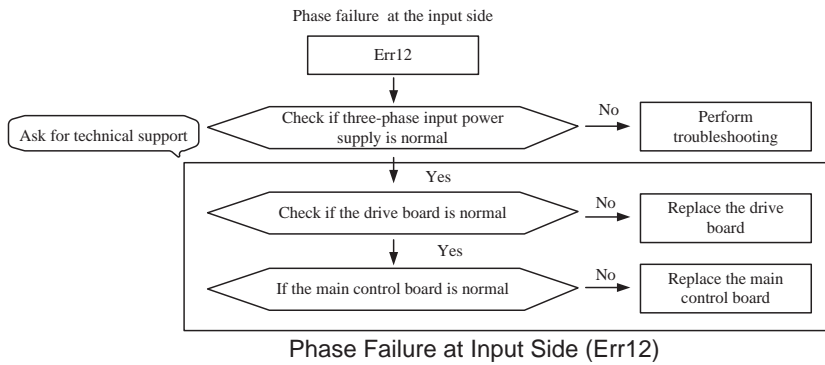

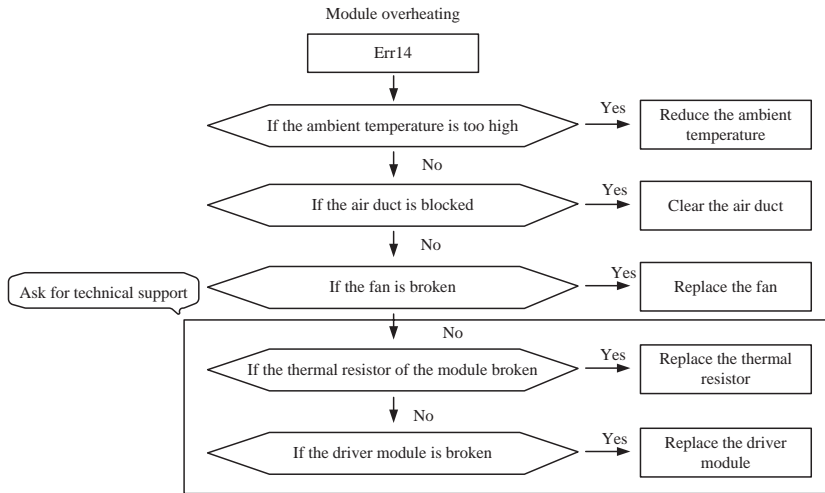

Module Overheating (Err14)

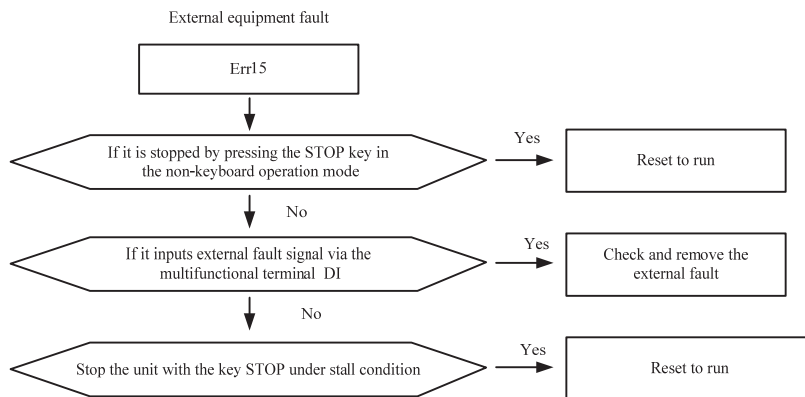

External Equipment Fault (Err15)

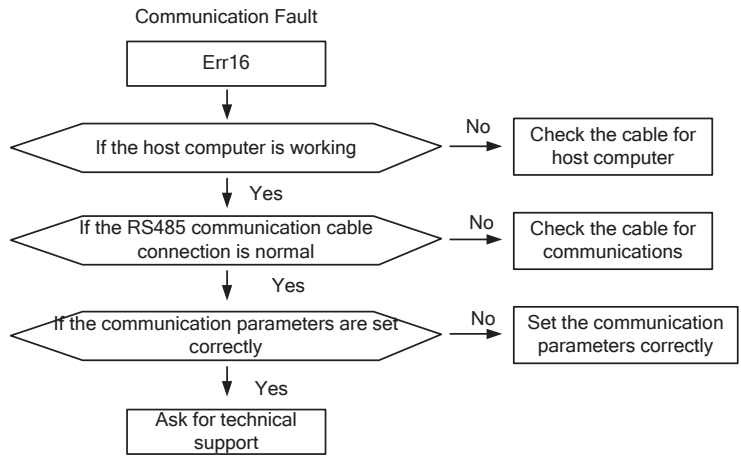

Communication Fault (Err16)

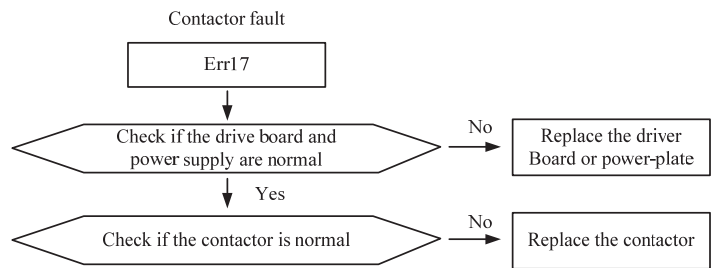

Contacteur Fault (Err17)

Current Detection Fault (Err18)

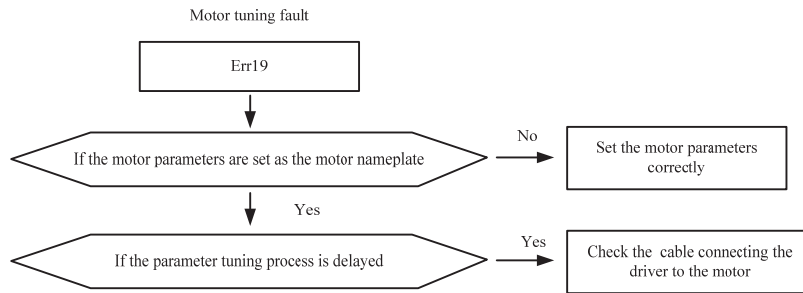

Motor Tuning Fault (Err19)

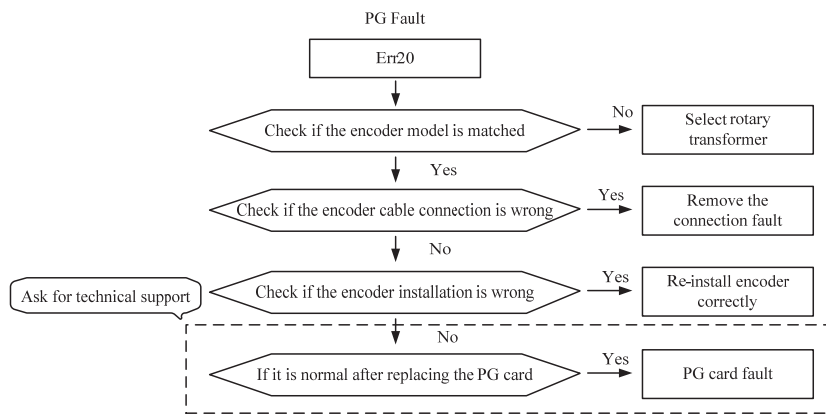

PG Fault (Err20)

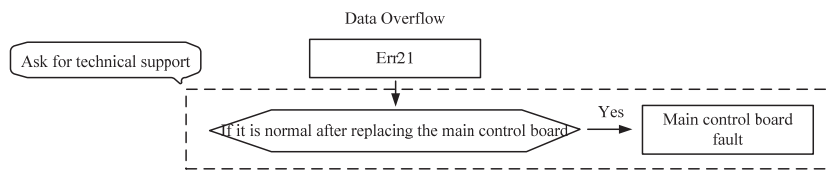

Data Overflow (Err21)

Err22 (Reserved)

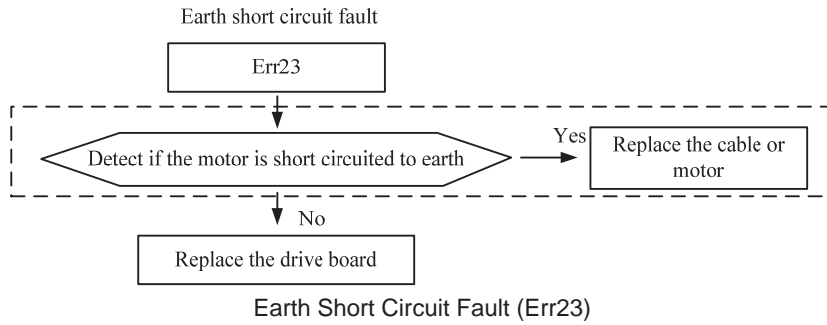

Err24 to Err41 (Reserved)

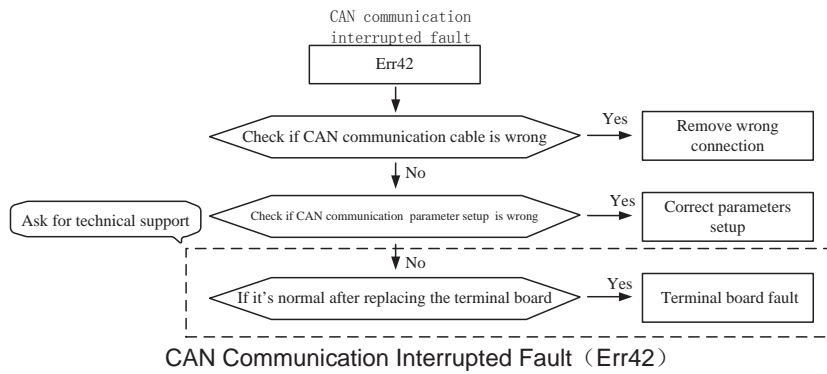

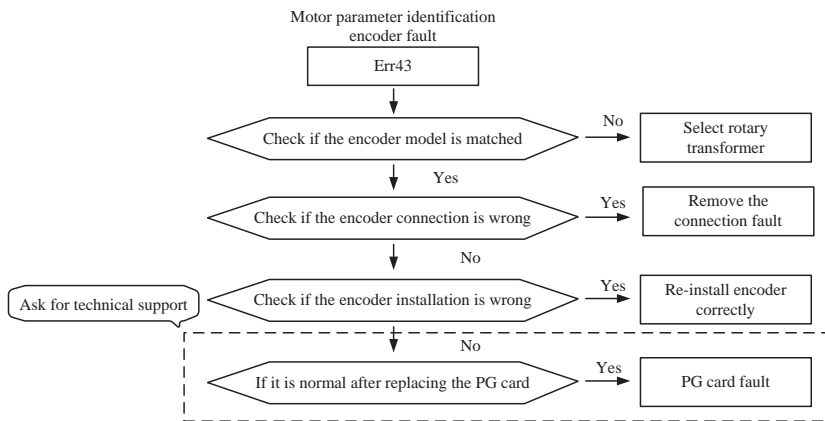

Motor Parameter Identify Encoder Fault (Err43)

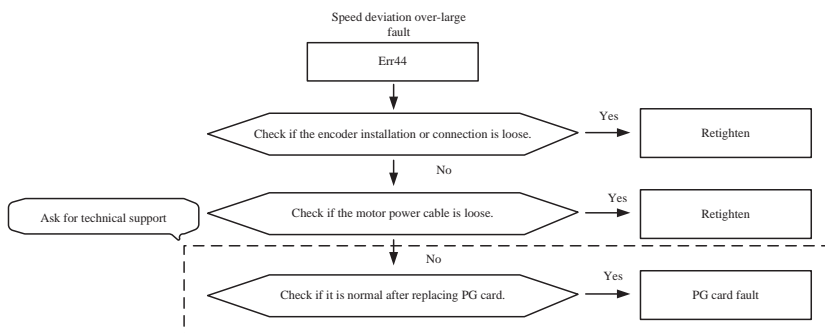

Speed Deviation Fault (Err44)

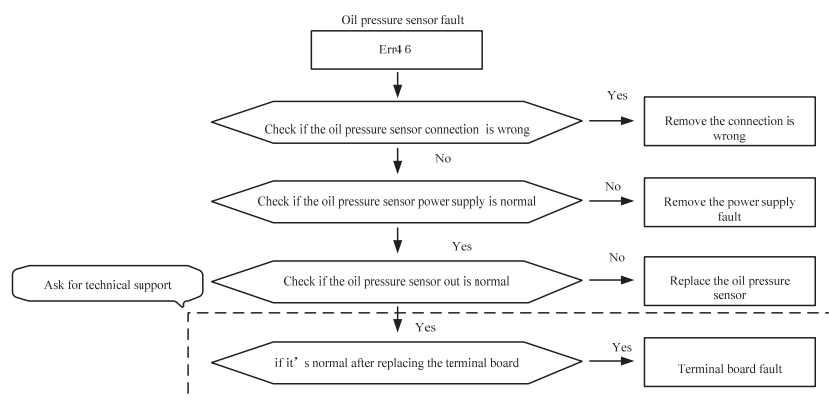
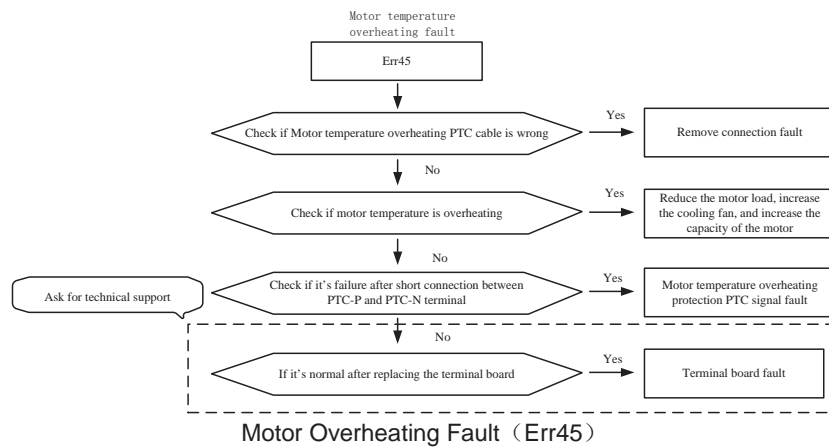

Note: Err47 and Err48 are the relevant failure contents for the multi-pump in parallel flow. If adopt the single pump control, please cut off DI5 input terminals. And if adopt pumps in parallel flow control, please refer to the multiple pump control solution.

4.2 Common Fault and Resolution

During the servo driver using process, the following faults may occur. Please conduct simple fault analysis by referring to the methods below:

No.	Fault Phenomenon	Possible Cause	Solution
1	No display upon power-on	<ol style="list-style-type: none"> 1. The driver has no input power supply. 2. 8-core bus connecting with the drive board and control board is in poor contact. 3. The internal parts of the driver are damaged. 	<ol style="list-style-type: none"> 1. Check the input power supply. 2. Plug/unplug the 8-core bus once again. 3. Consult the manufacturer.
2	HC is displayed upon power-on	<ol style="list-style-type: none"> 1. 4-core bus connecting with the drive board and control board is in poor contact. 2. Other parts of the driver are damaged. 	<ol style="list-style-type: none"> 1. Plug/unplug the 4-core bus once again. 2. Consult the manufacturer.
3	"Err23" alarm is displayed upon power-on.	<ol style="list-style-type: none"> 1. The motor or the output line is short circuited to the earth. 2. The driver is damaged. 	<ol style="list-style-type: none"> 1. Measure the insulation of the motor and output line with magneto-ohmmeter. 2. Consult the manufacturer.

No.	Fault Phenomenon	Possible Cause	Solution
4	The driver displays normally upon power-on, but "HC" is displayed upon running and stops immediately.	3. The fan is either damaged or blocked.	Replace the fan
5	Err14 (module overheating) fault is frequently reported.	<ol style="list-style-type: none"> 1. The carrier frequency is set too high. 2. The fan is damaged or the air duct is blocked. 3. The internal parts (thermal coupler or others) of the driver are damaged. 	<ol style="list-style-type: none"> 1. Reduce the carrier frequency (F0-15). 2. Replace the fan and clear the air duct. 3. Consult the manufacturer.
6	The motor does not rotate upon driver running.	<ol style="list-style-type: none"> 1. The motor is either damaged or blocked. 2. The parameters are set improperly (mainly Group F1 motor parameters). 	<ol style="list-style-type: none"> 1. Replace the motor or remove the mechanical fault. 2. Check and reset Group F1 parameters.
7	DI terminal inactive	1. The parameter is set wrongly.	1. Check and reset Group F4 related parameters.

No.	Fault Phenomenon	Possible Cause	Solution
		2. The short circuit copper bar between OP and +24V is loosen. 3. Control board fault.	2. Reconnect the cables. 3. Consult the manufacturer.
8	In the close loop vector control mode, the motor speed is always low.	1. The PG is damaged or cable connection is wrong. 2. The internal parts of the driver are damaged.	1. Replace the encoder and reconfirm the cable connection. 2. Consult the manufacturer.
9	The driver frequently reports over current fault and over voltage fault.	1. The motor parameters are set wrongly. 2. Speed-up and speed-down time is improper. 3. Load fluctuates.	1. Reset Group F1 parameters or perform motor tuning. 2. Set proper speed-up/speed-down time. 3. Consult the manufacturer.
10	Err17 alarm is reported upon power-on.	1. The soft start contactor is not switched on.	1. Check if the contactor cables are loosened; 2. Check if the contactor has fault; 3. Check if the 24V power supply of the contactor has fault; 4. Consult the manufacturer.



ISMG Servo Drive Using Instruction

Chapter 5 ISMG Servo Drive Using Instruction

5.1 ISMG Servo Drive Naming Rules

ISM G1-12D 20C D-R1 3 1 F

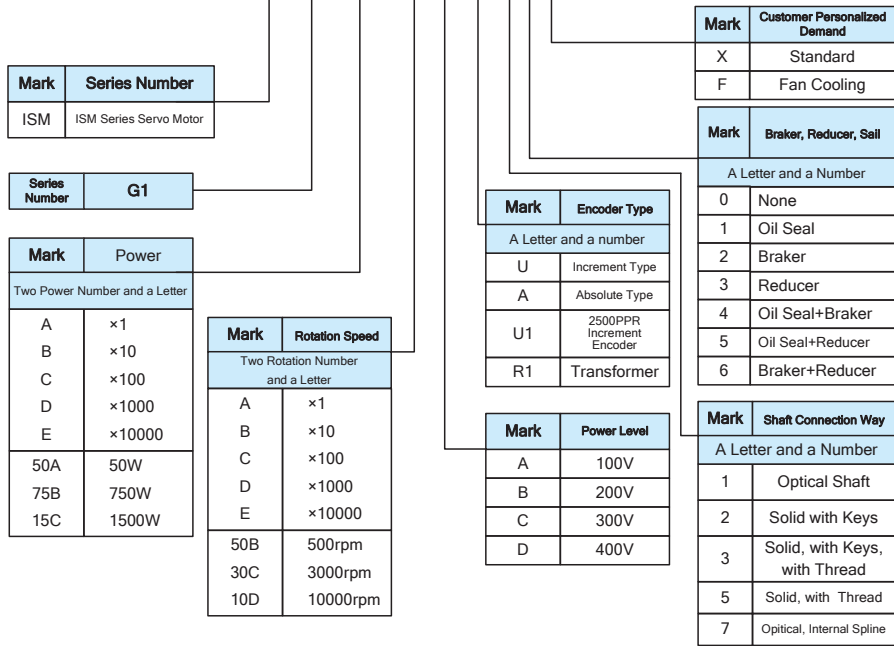

5.2 ISMG Servo Motor Performance Parameter

5.2.1 Forced Air Cooling Motor (ISMG*-*****-R1*1F)

Model	Rated Torque (Nm)	Speed (rpm)	Back-EMF (V)	Rated Voltage (V)	Rated Current (A)	Rated Power (kW)	Max. Torque (Nm)	Max. Speed (rpm)	Rotor Inertia (kgm ² ·10 ⁻³)	No. of Poles
ISMG1-63C10CD-R 131F	60	1000	305	345	13	6.3	152	1350	7.5	8
ISMG1-95C15CD-R 131F		1500	305	340	19	9.5	152	2000	7.5	8
ISMG1-11D17CD-R 131F		1700	296	333	23	11	152	2210	7.5	8
ISMG1-12D20CD-R 131F		2000	291	328	26	12.6	152	2500	7.5	8
ISMG1-95C10CD-R 131F	90	1000	310	355	18	9.5	250	1350	9	8
ISMG1-14D15CD-R 131F		1500	291	342	30	14.1	250	2000	9	8
ISMG1-16D17CD-R 131F		1700	296	340	34	16	250	2210	9	8
ISMG1-18D20CD-R 131F		2000	310	350	36	18.8	250	2500	9	8
ISMG1-14D10CD-R 131F	135	1000	291	345	29	14.1	358	1350	12	8
ISMG1-22D15CD-R 131F		1500	305	355	41	22	358	2000	12	8
ISMG1-24D17CD-R 131F		1700	296	343	50	24	358	2210	12	8
ISMG1-28D20CD-R 131F		2000	291	332	54	28.3	358	2500	12	8
ISMG1-20D10CD-R 131F	195	1000	310	350	40	20.5	485	1350	15	8
ISMG1-30D15CD-R 131F		1500	291	348	61	30.6	585	2000	15	8
ISMG1-41D20CD-R 131F		2000	310	358	76	41	585	2500	15	8

5.2.2 Natural Cooling Motor(ISMG*-*****-R1*1X)

Model	Rated Torque (Nm)	Speed (rpm)	Back-EMF (V)	Rated Voltage (V)	Rated Current (A)	Rated Power (kW)	Max. Torque (Nm)	Max. Speed (rpm)	Rotor Inertia (kgm ² 10 ⁻³)	No. of Poles
ISMG1-37C10CD-R 131X	35	1000	305	328	8	3.7	152	1350	7.5	8
ISMG1-55C15CD-R 131X		1500	305	325	11	5.5	152	2000	7.5	8
ISMG1-62C17CD-R 131X		1700	296	318	13	6.2	152	2210	7.5	8
ISMG1-75C20CD-R 131X		2000	291	313	15	7.5	152	2500	7.5	8
ISMG1-50C10CD-R 131X	48	1000	310	327	10	5	250	1350	9	8
ISMG1-75C15CD-R 131X		1500	291	312	16	7.5	250	2000	9	8
ISMG1-85C17CD-R 131X		1700	296	315	18	8.5	250	2210	9	8
ISMG1-11D20CD-R 131X		2000	310	325	20	11	250	2500	9	8
ISMG1-75C10CD-R 131X	70	1000	291	310	15	7.5	358	1350	12	8
ISMG1-11D15CD-R 131X		1500	305	325	21	11	358	2000	12	8
ISMG1-12D17CD-R 131X		1700	296	316	26	12	358	2210	12	8
ISMG1-15D20CD-R 131X		2000	291	308	28	15	358	2500	12	8
ISMG1-92C10CD-R 131X	89	1000	310	329	18	9.2	485	1350	15	8
ISMG1-13D15CD-R 131X		1500	291	309	28	13	585	2000	15	8
ISMG1-18D20CD-R 131X		2000	310	323	35	18.5	585	2500	15	8

5.3 ISMG Servo Motor Physical Dimension Diagram

5.3.1 Forced Air Cooling and Extended Shaft Motor (ISMG*-*****-R131F)

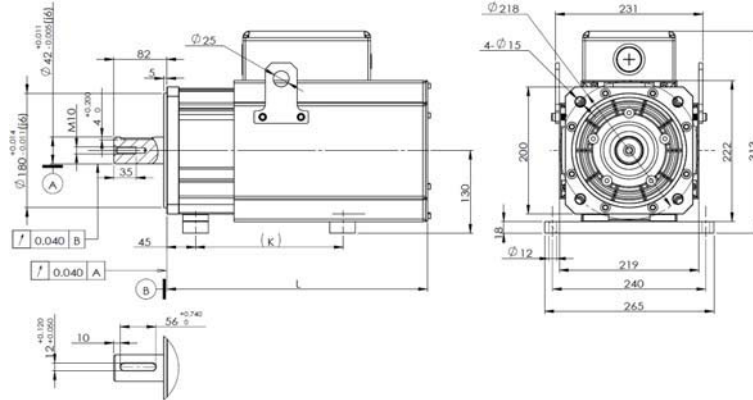

	ISMG1-63C10CD-R13 1F	ISMG1-95C10CD-R13 1F	ISMG1-14D10CD-R13 1F	ISMG1-20D10CD-R13 1F
	ISMG1-95C15CD-R13 1F	ISMG1-14D15CD-R13 1F	ISMG1-22D15CD-R13 1F	ISMG1-30D15CD-R13 1F
	ISMG1-11D17CD-R13 1F	ISMG1-16D17CD-R13 1F	ISMG1-24D17CD-R13 1F	ISMG1-41D20CD-R13 1F
	ISMG1-12D20CD-R13 1F	ISMG1-18D20CD-R13 1F	ISMG1-28D20CD-R13 1F	
L	360	395	471	550
K	190	230	305	380

5.3.2 Forced Air Cooling and Concave Shaft Motor (ISMG*-*****-R171F)

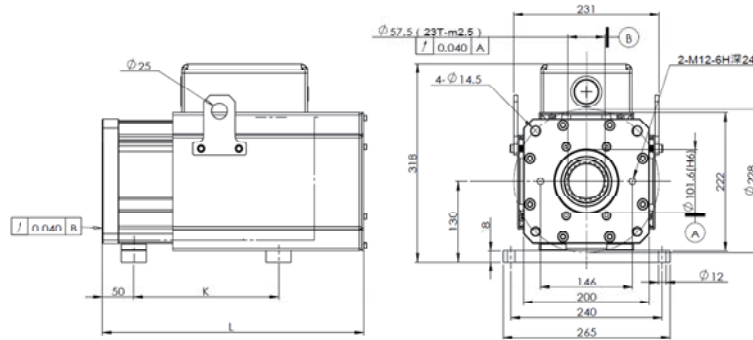

	ISMG1-63C10CD-R17 1F ISMG1-95C15CD-R17 1F ISMG1-11D17CD-R17 1F ISMG1-12D20CD-R17 1F	ISMG1-95C10CD-R17 1F ISMG1-14D15CD-R17 1F ISMG1-16D17CD-R17 1F ISMG1-18D20CD-R17 1F	ISMG1-14D10CD-R17 1F ISMG1-22D15CD-R17 1F ISMG1-24D17CD-R17 1F ISMG1-28D20CD-R17 1F	ISMG1-20D10CD-R17 1F ISMG1-30D15CD-R17 1F ISMG1-41D20CD-R17 1F
L	369	404	480	559
K	190	230	305	380

5.3.3 Forced Air Cooling and Extended Shaft Motor (ISMG*-*****-R131X)

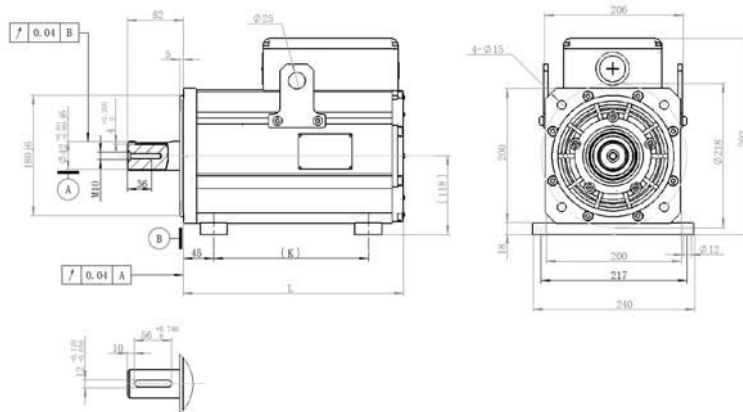

	ISMG1-37C10CD-R13 1X ISMG1-55C15CD-R13 1X ISMG1-62C17CD-R13 1X ISMG1-75C20CD-R13 1X	ISMG1-50C10CD-R13 1X ISMG1-75C15CD-R13 1X ISMG1-85C17CD-R13 1X ISMG1-11D20CD-R13 1X	ISMG1-75C10CD-R13 1X ISMG1-11D15CD-R13 1X ISMG1-12D17CD-R13 1X ISMG1-15D20CD-R13 1X	ISMG1-92C10CD-R13 1X ISMG1-13D15CD-R13 1X ISMG1-18D20CD-R13 1X
L	295	330	406	485
K	190	230	305	380

5.3.4 Natural Cooling and Concave Shaft Motor (ISMG*-*****-R171X)

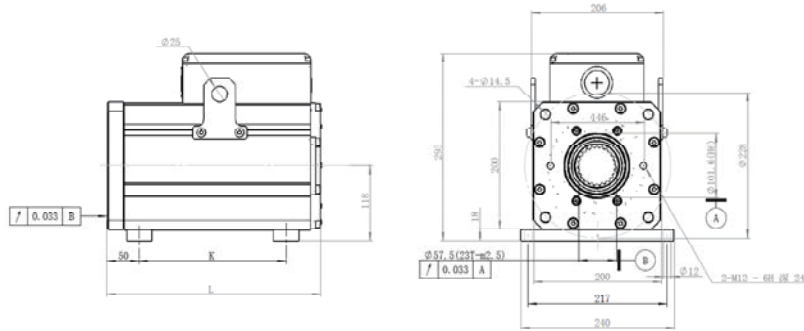

	ISMG1-37C10CD-R171X ISMG1-55C15CD-R171X ISMG1-62C17CD-R171X ISMG1-75C20CD-R171X	ISMG1-50C10CD-R171X ISMG1-75C15CD-R171X ISMG1-85C17CD-R171X ISMG1-11D20CD-R171X	ISMG1-75C10CD-R171X ISMG1-11D15CD-R171X ISMG1-12D17CD-R171X ISMG1-15D20CD-R171X	ISMG1-92C10CD-R171X ISMG1-13D15CD-R171X ISMG1-18D20CD-R171X
L	299	334	410	489
K	190	230	305	380

5.4 Instructions of Supporting Board of ISMG Servo Motor Base Installation

Model	Physical Dimensions	Instructions
ISMG1-B01	240x40x18	Installation Board-used for ISMG1 Natural Cooling Motor
ISMG1-B02	265x40x18	Installation Board-used for ISMG1 Fan Cooling Motor

5.5 ISMG Servo Motor Wiring Instructions

5.5.1 Signal Terminal Instructions 1 (With PCB Board)

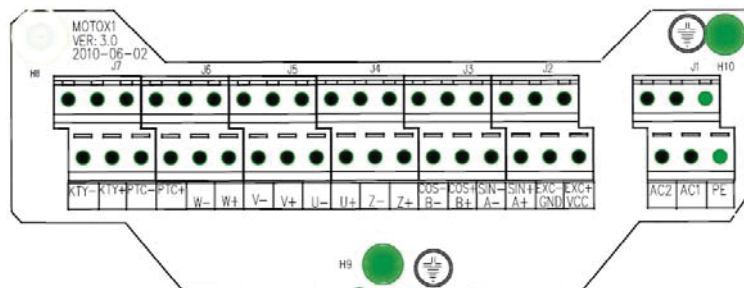

Note: 1) Every signal types are defined on PCB board. AC1 and AC2 are main power for cooling fan motor. AC1 and AC2 should be wired strictly following the signs.

2) Definition of Matched Signal Line of IS300 Servo Drive (For Reference)

Signal Definition	EXC -	EXC +	SIN +	SIN -	COS +	COS-	PTC +	PTC-
Drive Affiliated Encoder Cable Line	Red	Blue	Pink	Grey	Yellow	Green	White	Brown
Corresponding IS300 PG Card Pin	1	2	3	4	5	9	6	7

5.5.2 Definition of power terminals matched with PCB terminal board

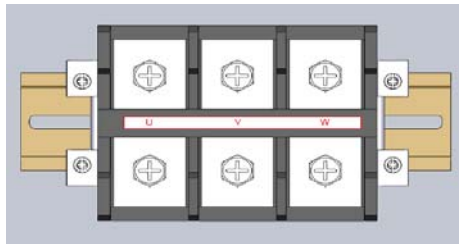

Note: 1) When wiring main power, phase sequence should accord with signs on the terminal

2) Please connect PE connection terminal to the fixed screw with the symbol  in the wiring box.

Appendix 1: Common Parameters Table

Function code	Name	LED display	Setup range	Minimum unit	Factory default value	Modification description
Group U0 Driver Parameter Viewing Group						
U0-00	Running frequency	Running frequency	0.00Hz to maximum frequency (F0-10)	—	—	•
U0-01	Setup frequency	Setup frequency	0.00Hz to maximum frequency (F0-10)	—	—	•
U0-02	Bus voltage	Bus voltage	0V to 830V	—	—	•
U0-03	Output voltage	Output voltage	0V to motor rated voltage (F1-02)	—	—	•
U0-04	Output current	Output current	0.01A to 655.35A	—	—	•
U0-05	Output power	Output power	0.4kW to 1000.0kW	—	—	•
U0-06	Output Torque	Output Torque	0.0% to Torque upper limit (F2-10)	—	—	•
U0-07	Local DI/DO status	Local DI/DO status				•
U0-08	Expansion DI / DO status	Expansion DI / DO status				•
U0-09	AI1 voltage(after corrected)	AI1 voltage(after corrected)	-10.00V to 10.000V	—	—	•

Function code	Name	LED display	Setup range	Minimum unit	Factory default value	Modification description
U0-10	AI2 voltage(after corrected)	AI2 voltage(after corrected)	-10.00V to 10.000V	—	—	•
U0-11	AI3 voltage(after corrected)	AI3 voltage(after corrected)	-10.00V to 10.000V	—	—	•
U0-12to U0-29	Reserved	—	—	—	—	•
U0-30	AI1 voltage(before corrected)	AI1 voltage(before corrected)	-10.00V to10.000V	—	—	•
U0-31	AI2voltage (before corrected)	AI2 voltage(before corrected)	-10.00V to10.000V	—	—	•
U0-32	AI3 voltage(before corrected)	AI3 voltage(before corrected)	-10.00Vto10.000V	—	—	•
Group A0 Weak Magnetism and SVC Control Group						
A0-00	Weak magnetism control mode	Weak magnetism control mode	0:Direct calculation 1:Automatic adjustment	1	0	★
A0-01	Weak magnetism current coefficient	Weak magnetism current coefficient	80% to 200%	1	100%	★

Function code	Name	LED display	Setup range	Minimum unit	Factory default value	Modification description
A0-02	Weak magnetism current upper limit	Weak magnetism current upper limit	0 to120	1	100	★
A0-03	Weak magnetism_Integral multiples	Weak magnetism_Integral multiples	200 to1000	1	400	★
A0-04	Weak magnetism coefficient	Weak magnetism coefficient	0 to100	1	4	★
A0-05	Output phase failure PWM detection time	Output phase failure PWM detection time	0 to 63000	1	0	★
Group A1 Group PG Card						
A1-00to A1-01	Reserved	-	-	-	-	★
A1-02	Encoder installation angle	Encoder installation angle	0.0° to 359.9°	0.1°	0.0°	☆
A1-03	Select the reverse direction feedback speed	Select the reverse direction feedback speed	0 to1	1	0	★

Function code	Name	LED display	Setup range	Minimum unit	Factory default value	Modification description
A1-04	Pole-pairs number of rotary transformer	Pole-pairs number of rotary transformer	1 to 50	1	1	★
Group A2 CAN Communication Group						
A2-00	Baud rate selection	Baud rate selection	0: 20k 1: 50k 2: 125k 3: 250k 4: 500k 5: 1M	1	5	☆
A2-01	CAN communication address	CAN communication address	1 to 255	1	1	☆
A2-02	CAN communication continuous time	CAN communication continuous time	0.0s (inactive) 0.1s to 5.0s	0.1s	0.3s	☆
Group A3 Servo Oil Pump Control Group						
A3-00	Oil pressure control mode	Oil pressure control mode	0:Non-oil pressure control mode 1:Driver oil pressure control mode 1(CAN setup) 2:Driver oil pressure control mode2(Analog channel setup) 3:CAN oil pressure mode(For special use) 4:Reserved	0	0	★

Function code	Name	LED display	Setup range	Minimum unit	Factory default value	Modification description
A3-01	Maximum rotation speed	Maximum rotation speed	Maximum frequency lower limit corresponding to rotation speed ~ 30000rpm	1rpm	2000 rpm	★
A3-02	System oil pressure	System oil pressure	0.0kg/cm ² to maximum oil pressure(A3-03)	0.0kg/cm ²	175.0kg/cm ²	☆
A3-03	Maximum oil pressure	Maximum oil pressure	System oil pressure(A3-02) to 500.0kg/cm ²	0.0kg/cm ²	250.0kg/cm ²	☆
A3-04	Oil pressure command risetime	Oil pressure command risetime	0ms to 2000ms	1ms	20ms	☆
A3-05	Oil pressure control Kp1	Oil pressure control Kp1	0.0 to 800.0	0.1	210.0	☆
A3-06	Oil pressure control Ti1	Oil pressure control Ti1	0.001s to 10.000s	0.001 s	0.100s	☆
A3-07	Oil pressure control Td1	Oil pressure control Td1	0.000s to 1.000s	0.001 s	0.000s	☆
A3-08	Maximum reverse rotation speed	Maximum reverse rotation speed	0.0% to 100.0%	0.1%	20.0%	☆

Function code	Name	LED display	Setup range	Minimum unit	Factory default value	Modification description
A3-09	Minimum flow	Minimum flow	0.0% to 50.0%	0.1%	0.5%	☆
A3-10	Minimum pressure	Minimum pressure	0.0 kg/cm ² to 50.0 kg/cm ²	0.1kg/cm ²	0.5kg/cm ²	☆
A3-11	Oil pressure control Kp2	Oil pressure control Kp2	0.0 to 800.0	0.1	210.0	☆
A3-12	Oil pressure control Ti2	Oil pressure control Ti2	0.001s to 10.000s	0.001 s	0.100s	☆
A3-13	Oil pressure control Td2	Oil pressure control Td2	0.000s to 1.000s	0.001 s	0.000s	☆
A3-14	Oil pressure control Kp3	Oil pressure control Kp3	0.0 to 800.0	0.1	210.0	☆
A3-15	Oil pressure control Ti3	Oil pressure control Ti3	0.001s to 10.000s	0.001 s	0.100s	☆
A3-16	Oil pressure control Td3	Oil pressure control Td3	0.000s to 1.000s	0.001 s	0.000s	☆
A3-17	Oil pressure control Kp4	Oil pressure control Kp4	0.0 to 800.0	0.1	210.0	☆

Function code	Name	LED display	Setup range	Minimum unit	Factory default value	Modification description
A3-18	Oil pressure control Ti4	Oil pressure control Ti4	0.001s to 10.000s	0.001 s	0.100s	☆
A3-19	Oil pressure control Td4	Oil pressure control Td4	0.000s to 1.000s	0.001 s	0.000s	☆
A3-20	AI zero drift auto correction	AI zero drift auto correction	0: Disabled 1: Enabled	0	0	☆
A3-21	Fault detection time of oil pressure sensor	Fault detection time of oil pressure sensor	0.000s : Detection inactive 0.001s to 60.000s	0.001 s	0.500s	☆
A3-22	Pressure control status output maximum speed setup	Pressure control status output maximum speed setup	0.0% to100.0%	0.1%	20.0%	☆
A3-23	Pressure control status output minimum oil pressure setup	Pressure control status output minimum oil pressure setup	0.0%to100.0%	0.1%	65.0%	☆

Function code	Name	LED display	Setup range	Minimum unit	Factory default value	Modification description
A3-24	Pressure control status output minimum delay time	Pressure control status output minimum delay time	0.000s to 10.000s	0.001 s	0.100s	☆
A3-25	Command pressure S filter time	Command pressure S filter time	0.000s to 10.000s	0.001 s	0.030s	☆
A3-26 ~ A3-31	(Maintain)	-	-	-	-	-
A3-32	Slave min. input	Slave min. input	0.0%~ A3-34	0.1%	0.0%	☆
A3-33	Slave min. input correspondence	Slave min. input correspondence	-100.0% ~100.0%	0.1%	0.0%	☆
A3-34	Slave mid-point input	Slave mid-point input	A3-32~ A3-36	0.1%	0.0%	☆
A3-35	Slave mid-point input correspondence	Slave mid-point input correspondence	-100.0% ~100.0%	0.1%	0.0%	☆
A3-36	Slave max. input	Slave max. input	A3-34 ~ 100%	0.1%	100.0%	☆

Function code	Name	LED display	Setup range	Minimum unit	Factory default value	Modification description
A3-37	Slave max. input correspondence	Slave max. input correspondence	-100.0% ~100.0%	0.1%	100.0%	☆
Group F0 Basic Function Group						
F0-02	Command source selection	Command source selection	0: Operation panel running command channel (LED OFF) 1: Terminal command channel (LED ON)	1	0	☆
Group F1 Motor Parameters						
F1-00	Motor type selection	Motor type selection	0: Common asynchronous motor 1: Variable frequency asynchronous motor 2: Permanent magnetic synchronous motor	1	2	★
F1-01	Rated power	Rated power	0.4kW to 1000.0kW	0.1kW	Model dependent	★
F1-02	Rated voltage	Rated voltage	0V to 440V	1V	Model dependent	★
F1-03	Rated current	Rated current	0.01A to 655.35A	0.01A	Model dependent	★
F1-04	Rated frequency	Rated frequency	0.00 to maximum frequency	0.01Hz	Model dependent	★

Function code	Name	LED display	Setup range	Minimum unit	Factory default value	Modification description
F1-05	Rated rotation speed	Rated rotation speed	0rpm to 30000rpm	1rpm	Model dependent	★
F1-15	Back EMF	Back EMF	0 to 65535V	1	Model dependent	★
F1-16	Tuning selection	Tuning selection	0: No operation 1: Static tuning(low speed) 2: Dynamic tuning (high speed)	1	0	★
GroupF2 Control Parameters						
F2-00	Speed loop proportional gain 1	Speed loop P1	0 to100	1	60	☆
F2-01	Speed loop integration time 1	Speed loop I1	0.01s to10.00s	0.01s	0.30s	☆
F2-03	Speed loop proportional gain 2	Speed loop P2	0 to100	1	60	☆
F2-04	Speed loop integration time 2	Speed loop I2	0.01s to10.00s	0.01s	0.30s	☆
F2-10	Torque upper limit	Torque upper limit	0.0% to 250.0%	0.1%	200.0%	☆

Function code	Name	LED display	Setup range	Minimum unit	Factory default value	Modification description
F2-13	D-axis current loop Kp	D-axis current loop Kp	0 to 65535	1	50	☆
F2-14	D-axis current loop Ki	D-axis current loop Ki	0 to 65535	1	50	☆
F2-15	Q-axis current loop Kp	Q-axis current loop Kp	0 to 65535	1	50	☆
F2-16	Q-axis current loop Ki	Q-axis current loop Ki	0 to 65535	1	50	☆
Group F4 Input Terminal						
F4-32	A13 input filtering time	A13 filtering time	0.00s to 10.00s	0.01s	0.00s	☆
Group F7 Keyboard and Display						
F7-10	Software version No.1	Software version No.1	-	-	-	●
F7-11	Software version No.2	Software version No.2	-	-	-	●
Group FP User Password						
FP-00	User password 1	Authorization for all functions code except FP-05	0 to 65535	1	0	☆

Function code	Name	LED display	Setup range	Minimum unit	Factory default value	Modification description
FP-01	Parameter initialization	Parameter initialization	0:No operation 1:Restore the factory default setup value 2: Clear the fault record 3:Restore the setup function code value of FP-05 saved.	1	0	★
FP-02	Motor specification solidification	Motor specification	0 to 65535	1	0	★
FP-03	Injection molding machine specification solidification	Injection molding machine specifications	0 to 65535	1	0	★
FP-04	User password 2	Authorization for FP-05 function code	0 to 65535	1	0	★
FP-05	Function code setup values in real time saved	Save the currently set values for all the function code	0: No operation 1: Save the currently set values for all the function code	1	0	★

Appendix 2 Servo Motor Code Table

Model Type		Motor Specification (FP-02)
ISMG1-63C10CD-R131F	ISMG1-63C10CD-R171F	00610
ISMG1-95C15CD-R131F	ISMG1-95C15CD-R171F	00615
ISMG1-11D17CD-R131F	ISMG1-11D17CD-R171F	00617
ISMG1-12D20CD-R131F	ISMG1-12D20CD-R171F	00620
ISMG1-95C10CD-R131F	ISMG1-95C10CD-R171F	00910
ISMG1-14D15CD-R131F	ISMG1-14D15CD-R171F	00915
ISMG1-16D17CD-R131F	ISMG1-16D17CD-R171F	00917
ISMG1-18D20CD-R131F	ISMG1-18D20CD-R171F	00920
ISMG1-14D10CD-R131F	ISMG1-14D10CD-R171F	01310
ISMG1-22D15CD-R131F	ISMG1-22D15CD-R171F	01315
ISMG1-24D17CD-R131F	ISMG1-24D17CD-R171F	01317
ISMG1-28D20CD-R131F	ISMG1-28D20CD-R171F	01320
ISMG1-20D10CD-R131F	ISMG1-20D10CD-R171F	01910
ISMG1-30D15CD-R131F	ISMG1-30D15CD-R171F	01915
ISMG1-41D20CD-R131F	ISMG1-41D20CD-R171F	01920
ISMG1-37C10CD-R131X	ISMG1-37C10CD-R171X	00310
ISMG1-55C15CD-R131X	ISMG1-55C15CD-R171X	00315
ISMG1-62C17CD-R131X	ISMG1-62C17CD-R171X	00317
ISMG1-75C20CD-R131X	ISMG1-75C20CD-R171X	00320
ISMG1-50C10CD-R131X	ISMG1-50C10CD-R171X	00410
ISMG1-75C15CD-R131X	ISMG1-75C15CD-R171X	00415
ISMG1-85C17CD-R131X	ISMG1-85C17CD-R171X	00417
ISMG1-11D20CD-R131X	ISMG1-11D20CD-R171X	00420
ISMG1-75C10CD-R131X	ISMG1-75C10CD-R171X	00710
ISMG1-11D15CD-R131X	ISMG1-11D15CD-R171X	00715
ISMG1-12D17CD-R131X	ISMG1-12D17CD-R171X	00717
ISMG1-15D20CD-R131X	ISMG1-15D20CD-R171X	00720
ISMG1-92C10CD-R131X	ISMG1-92C10CD-R171X	00810
ISMG1-13D15CD-R131X	ISMG1-13D15CD-R171X	00815
ISMG1-18D20CD-R131X	ISMG1-18D20CD-R171X	00820



Warranty Agreement

1. The warranty period of the product is 18 months (refer to the barcode on the equipment body). During the warranty period, if the product fails or is damaged under the condition of normal use by following the instruction, Our Company will be responsible for free maintenance.
2. Within the warranty period, maintenance will be charged for the damages caused by the following reasons:
 - a. The damage caused by improper use or repair/modification without prior permission;
 - b. The damage caused by fire, flood, abnormal voltage, other disasters and second disaster;
 - c. The hardware damage caused by dropping or transportation upon the procurement.
 - d. The damage caused by the improper operation;
 - e. The damage or failure caused by the trouble out of the equipment (e.g. external device)
3. If there is any failure or damage to the product, please correctly fill out the Product Warranty Card in detail.
4. The maintenance fee is charged according to the newly adjusted Maintenance Price List by our company.
5. In general, the warranty card will not be re-issued. Please keep the card and present it to the maintenance personnel when asking for maintenance.
6. If there is any problem during the service, please contact the agent of our company or our company directly.
7. This agreement shall be interpreted by Shenzhen Inovance Technology Co., Ltd.

Shenzhen Inovance Technology Co., Ltd.

Service Center

Address: Block E, Hongwei Industry Park, Liuxian Road, Baocheng No. 70 Zone, Bao'an District, Shenzhen

Tel: 400-777-1260

P.C.: 518101

Website: www.inovance.cn



Product Warranty Card

Customer information	Add. of unit:	
	Name of unit:	Contact person:
	P.C.:	Tel.:
Product information	Product model:	
	Body barcode (Attach here):	
	Name of agent:	
Failure information	(Maintenance time and content):	
	Maintenance personnel:	