

Preface

Thank you for purchasing NICE900 Door machine controller.

This instruction manual describes how to properly use NICE900 Door machine controller. Please read the instruction manual carefully before using (Before installation, operation, maintenance and inspection). Besides, please use the product after understanding the safety precautions.

Precautions

- **The drawings presented in this instructions are sometimes shown without covers or protective guards. Always replace the equipment's cover or protective guard as specified first, and then operate the products in accordance with the instructions.**
- **The drawings presented in the instructions are typical examples and may not match the product you received.**
- **These instructions are subject to change due to product improvement, specification modification, specification modification.**
- **If you want to order the manual due to loss or damage, please contact our company agents in each region or our company customer service center directly.**
- **If there is still any problem during using the product, please contact our company customer service center directly.**
- **Our Service Hotline: 400-777-1260.**

Contents

Preface	1
Chapter 1 Safety and Precautions	6
1.1 Safety Items.....	6
1.2 Attention Items.....	9
Chapter 2 Product information	12
2.1 Name designation & nameplate.....	12
2.2 Technical specification.....	13
2.3 Product appearance and install hole dimension	14
2.4 Daily maintenance	14
2.5 option units – brake unit model	16
Chapter 3 Electric installation.....	18
3.1 Installing environment	18
3.2 Electric installation	18
3.3 Wiring terminal introduction	18
3.4 Other interfaces	20
Chapter 4 Door machine controller & Trial run.....	22
4.1 Operation & display	22
4.2 The basic operation of controller	23
Chapter 5 Function parameter table.....	26
5.1 function parameter table	26
5.2 function table.....	26
Chapter 6 Function parameter specification	44
6.1 F0 Basic function parameter	44
6.2 F1- motor parameter	46
6.3 F2 Performance control parameter	48
6.4 F3 – open-door run parameter	51
6.5 F4- Door closing run curve	54
6.6 F5-Door auxiliary parameter	57

6.7 F6-Distance control parameter	60
6.8 F7-Demonstrating function parameter	63
6.9 F8-Auxiliary parameter	64
6.10 F9-I/O function parameter.....	66
6.11 FA-Display & Error parameter	68
6.12 FP-user parameter.....	73
Chapter 7 Application and adjustment	76
7.1 Door machine controller adjustment	76
7.2 Typical application	79
Chapter 8 Fault Diagnosis and Countermeasures.....	84
Chapter 9 ISMD1-5B0180A-I120XP PMSM specification	88
9.1 Motor parameter and size	88
9.2 encoder parameter	89
9.3 Motor torque calculation and motor selection instruction	89





Safety and Precautions

Chapter 1 Safety and Precautions

Safety definition:

There are two kinds of safety items in this manual:

 Danger

Failure to follow the instructions will result in death or serious injury.

 Note

Failure to follow these instructions can result in medium hurt or equipment damage.

Please read this manual carefully and operate strictly according to the safety tips while installing, debugging, maintaining the system. MONARCH company is free of charge to any damage or loss caused by any operations that not performed according to the requirements.

1.1 Safety Items

1.1.1 Before Installation

 Danger

- Do not install in the condition of water seepage in the control system, components scarcity or damage while opening the case!
- Do not install while the packing list is not in the accordance with the products!

 Note

- Please uplift and drop gently in the portage otherwise the equipment will be damaged!
- Do not touch the elements of the controller with your hands, otherwise the static electricity hurt may be caused!

1.1.2 During Installation

 Danger

- Please mount the controller on incombustible surface like metal, and keep away from flammable substances! Otherwise it may cause fire!
- Do not twist the fixing bolts of the components, especially the bolts with red marks!

**Note**

- Do not let wiring terminal or screw enter the controller, otherwise the controller will be damaged!
- Install the controller where there's less shaking and no direct sunshine.

1.1.3 Wiring**Danger**

- Only the qualified electrical engineer can perform the wiring, otherwise there will be danger of electric shock.
- A circuit breaker must be installed between the power supply and the controller; otherwise there will be danger of fire.
- Please connect the controller to the ground according to the requirements, otherwise it will be dangerous

**Danger**

- Do not connect the input current with the controller's output terminals (U, V, W). Please note the marks and do not connect the wrong wires otherwise the controller may be damaged!
- Ensure the wiring meet the EMC requirements and the local safety standard. The wire size shall be determined according to the manual, otherwise accidents may occur!
- Encode connection must use Shielded line, shielding layer must be one side connected to earth reliably!
- Communication wires must use STP with the lay of 20mm~30mm, shielding layer must be connected to earth!

1.1.4 Before Power-on**Note**

- Please confirm the mains voltage level is consistent with that of the controller ;the input (L1,L2) and output (U,V,W) wirings are correct; and check if there is any short circuit in peripheral circuit and if the wiring is fixed and fasten; otherwise the controller may be damaged!
- Please do the motor parameter tuning before first running. Otherwise there will be danger of reveling over-speed.
- No part of controller needs further withstand voltage testing since it has been done in the factory; Otherwise accidents will occur!

**Danger**

- Mount the cover plate properly before power-on the controller; otherwise there will be danger of electric shock!
- All the external parts wirings must be connected according to the instruction of this manual, otherwise accidents may occur!

1.1.5 After Power-on**Danger**

- Do not open the cover of the controller after power-on, otherwise there will be danger of electric shock!
- Do not touch the controller terminals; otherwise there will be danger of electric shock.

**Danger**

- If parameter identification is required, please pay attention that the rotating motor may injure people, otherwise accident may occur!
- Do not change the factory settings; otherwise the equipment may be damaged!

1.1.6 Running



Danger

- Do not touch the fan and the discharging resistor to check the temperature, otherwise burning will occur!
- Only the qualified technician can check the signal while it's running. Otherwise there will be danger of personal injury or equipment damage!



Note

- Do not let objects fall in a running controller; otherwise the controller may be damaged!
- Do not start and stop the controller by on/off of the contactor, otherwise the controller may be dangerous.

1.1.7 Maintenance



Danger

- Please do not repair or maintain the controllers with power on, otherwise there will be danger of electric shock!
- Only qualified electrical engineer can repair or maintain the controller, otherwise there will be danger of human injury or damaging the equipment.
- Reset the parameters after changing the controller; all the insets must be unplugged while the power is switch-off!

1.2 Attention Items

1.2.1 Motor insulation check

When the motor is used for the first time, or reused after storing for a long time, or in a regular checkup, the user must check the insulation of the motor to prevent the poor insulation of the windings of motor from damaging the controller. The motor connection must be divided from the controller during the insulation check. It is recommended to use a 500V Mega-Ohm-Meter to check and the insulation resistance shall not be less than 5MΩ.

1.2.2 Motor Heat and Noise

Since the output voltage of the controller is in PWM wave with some harmonic wave, the temperature may raise, the noise and vibration may increase compared with the controller running at main frequency.

1.2.3 Pressure-sensitive Device or Capacitor at the Output Side of the Controller

Because the controller outputs PWM wave, the capacitor used for improving power factor and pressure-sensitive resistor used for lightning-proof shouldn't be installed at the output side of the controller. Otherwise the controller may have transient over-current and may be damaged.

1.2.4 Usage out of the Range of Rated Voltage

The NICE1000 controller shall not be used out of the specified range of operation voltage. Otherwise the internal components of the controller may be damaged. If needed, please use corresponding voltage regulation device to change the voltage.

1.2.5 Lightning Strike Protection

There are lightning protection devices inside the controller, but the user should install other lightning protection device at the front end of the controller if lightning strike occurs frequently.

1.2.6 Altitude and De-rating

When the altitude is higher than 1000m, the cooling effect of consult is deteriorated because of the rarefaction of air, then it is a necessity to derate the use of controller and please contact our company for detailed technical support in this circumstance.

1.2.7 Cautions for Scrap of controller

The electrolytic capacitors in the main circuits and PCB may explode when they are burned and poisonous gas may be generated when the plastic parts are burned. Please dispose the controller as industrial rubbish.

1.2.8 About Applicable Motor

- 1) The controller is applicable to squirrel-cage Asynchronous motor and AC permanent-magnet Synchronous motor. Please be sure to select the applicable controller according to the Data plate of the motor.
- 2) The controller has already been configured with default parameters which is applicable to squirrel-cage Asynchronous motor. To perform the motor parameter identification according to the actual conditions will promote the operation effect. Synchronous motor must carry out parameter tuning.
- 3) The output part of controller should not be short. Otherwise the controller may alarm or be damaged. Therefore, before Power-on, we must execute short-circuit-test for new elevator. Please make sure that the controller be cut from the testing parts when the testing is undergoing.



Product information

Chapter 2 Product information

2.1 Name designation & nameplate

2.1.1 Name designation

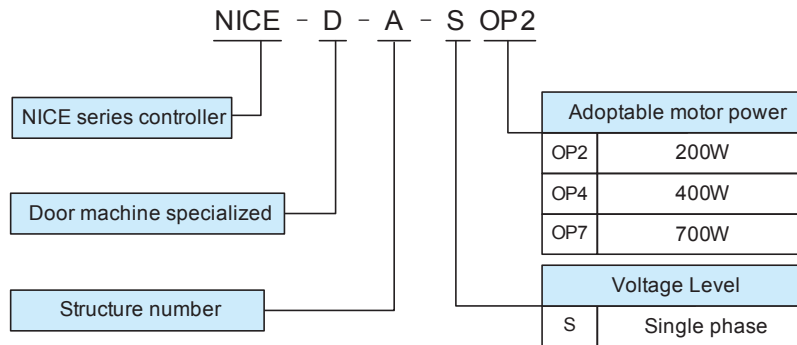

Model	Input voltage	Power capacity (kVA)	Input current (A)	Output current (A)	Adoptable motor (W)
NICE-D-A-S0P2	1 phase 187~264V	0.5	2.7	1.3	200
NICE-D-A-S0P4		1.0	5.4	2.3	400
NICE-D-A-S0P7		1.5	8.2	4.0	750

2.1.2 Nameplate

MODEL	NICE-D-A-S0P2
POWER	200W
INPUT	1PH AC220V 2.7A 50Hz/60Hz
OUTPUT	3PH AC0V~220V 1.3A 0Hz~99Hz
S/N	_____

2.2 Technical specification

Table 2-1

Item	Sub-item	Technical specification
Performance control	Max. output freq.	99.00Hz
	Speed range	1:50 (magnetic flux vector control), 1:1000 (close-loop vector control)
	Speed precision	±0.5% (magnetic flux vector control), ±0.05% (close-loop vector control)
	Starting torque	0Hz 180% (close-loop vector control) 1Hz 150% (magnetic flux vector control)
	Freq. resolution ratio	0.01Hz
	Current resolution ratio	0.01A
	Carrier wave freq.	2K~16K
Main functions	Asynchronous motor : static/dynamic motor tuning Sync motor: non-load, loaded motor tuning and coder zero position	
	Sync motor: general AB2 coder, open-circuit collector output or push-pull output	
	Magnetic flux vector control mode: auto torque hoist, manual torque hoist, over-excitation.	
	Distance control, support direct stop.	
	Door width auto-tuning is available.	
	Auto demonstrating function is available	
	Obstacle auto- identification function is available	
Protection	Overload protection, rated current 150% 1 minute protection, 180% 1 s protection.	
Environmental requirements	Suitable environment	Inside of a room no direct sunlight, no dust, no corrosive gases, no combustible gases, oil dust, no reek, salt etc.
	altitude	Normally lower than 1000m. Please de-rate the use if higher than 1000m.
	Ambient temperature	-10℃~+40℃ (de-rate in 40℃~50℃,)
	humidity	< 95%RH, no bead
	Vibration	< 5.9m/s ² (0.6g)
	Storage temperature	-20℃~+60℃
	Cooling method	0.2kW self-cooling, 0.4kW and 0.75kW air-cooling
	Protection level	IP21
	Store place	Stored in dry and clean place.
	Conveyance	Can be transported by car, train, plane, ship in a standard packing box.
	Convey vibration	When sin vibration is 9- 200 Hz, 15m/s ² (1.5g)

2.3 Product appearance and install hole dimension.

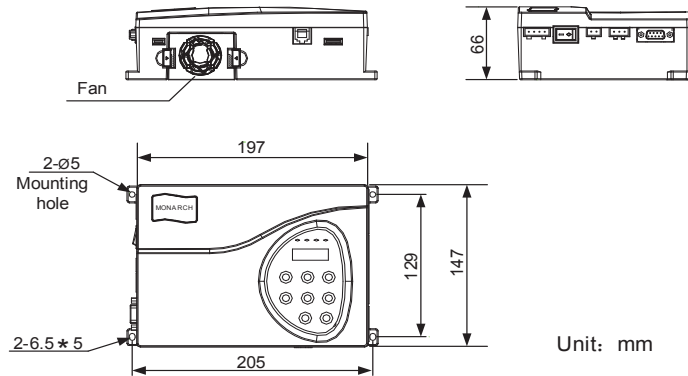

Fig 2-3 Product appearance

2.4 Daily maintenance

2.4.1 Daily maintenance

Since the influence of ambient temperature, humidity, dust, and vibration, the components in controller may become aging and wearing, which will give rise to the occurrence of potential faults and reduce the life of controller. Therefore, it is quite necessary to do the work of daily maintenance of controller.



Danger

The filter capacitor still has high voltage after the power supply to the controller is switched off, so do not maintain or repair the controller until the bus voltage measured after 10 minutes with the multi-meter. The voltage must be lower than 36V.

- 4) Daily checking items:
 - a) Check if there is any abnormal noise during the running of motor;
 - b) Check if there is any vibration of motor ;
 - c) Check if the installation environment of controller changes ;
 - d) Check if the cooling fan of controller works normally ;
 - e) Check if the controller is over heated.
- 5) Daily Cleaning:
 - a) Keep the controller in a clean status;
 - b) Clean the dust from the controller and prevent the dust especially the metal powder

from entering the controller;

- c) Clean the oil dirt in the cooling fan of the controller.

2.4.2 Periodical Checking

Periodically check the places that are hardly checked during the running.

1) Periodical Checking Items

- a) Check the ventilation channels and clean them periodically;
- b) Check if the screws are loose;
- c) Check if the controller is rusted;
- d) Check if the input / output terminals has scratch marks;
- e) Check the insulating in main circuit.

Note: Insulation test (use 500V Mega-Ohm-Meter) should be done separately after disconnecting the input power cables from the controller; or else, the controller will be damaged. Do not use the Mega-Ohm-Meter to test the insulation of control circuits. Dielectric strength test had been done at factory. Therefore, user need not do this test again.

2) Replacement of Wearing Parts

The wearing parts of controller mainly include the cooling fan and filtering electrolytic capacitor. Their lifetime is closely related to the operating environment and maintenance.

General lifetime as follows:

Component	Lifetime
Fan	2 ~ 3 years
Electrolytic capacitor	4 ~ 5 years

Uses could determine when to replace them according to their work time.

3) Cooling fan

Possible damage causes: shaft bearing attrition and blade aging.

Criteria: no crack on fan blade, no abnormal vibration noise at start.

4) Filtering electrolytic capacitor

Possible damage causes: high ambient temperature, big pulsating current due to frequent load fluctuation, electrolyte aging.

Criteria: no liquid leak, no protrusion of safety valve, electrostatic capacitance measurement, and insulation resistance measurement.

2.4.3 Controller Storage

The following points must be noticed in controller storage:

- 5) It is recommended to store the controller in its original packing box.
- 6) Long-term storage will cause deterioration of electrolytic capacitor. Therefore, controllers not in service for a long time must be powered for at least once within 2 years for testing purpose, at least for 5 hours ; in the test , the input voltage must be boosted gradually with voltage regulator to the rated value.

2.5 option units – brake unit model

Controller model	Recommended power	Recommended resistance
NICE-D-A-S0P2	80W	$\geq 250\Omega$
NICE-D-A-SOP4	80W	$\geq 200\Omega$
NICE-D-A-SOP7	80W	$\geq 150\Omega$



Electric installation

Chapter 3 Electric installation

This chapter will give the introduction of setting, specification, wiring of different I/O terminals.

3.1 Installing environment

- 1) Temperature: The ambient temperature will bring great affect to the life of controller. The allowable extent is $-10^{\circ}\text{C}\sim+50^{\circ}\text{C}$.
- 2) Mount the controller on incombustible surface (such as metal) with enough space to spread heat. And use screw to mount it vertically on the bracket.
- 3) Avoid places with direct sunshine or dampness.
- 4) Avoid place with corrosive, flammable, explosive gas
- 5) Avoid places with oil dirt, dust or metal powder.

3.2 Electric installation

3.2.1 Model Selection of Peripheral Electrical Components

Controller Model	Circuit Breaker (A)	Contactor (A)	Conducting Wire of Main Circuit (mm)
NICE-D-A-S0P2	10	10	2.5
NICE-D-A-S0P4	16	10	2.5
NICE-D-A-S0P7	16	10	2.5

3.2.2 Periphery electric unit instruction

Unit name	position	Function details
Air breaker switch	The most front-end of controller drive power input	Cut off the power and provide short protection. This switch is essential.
AC input reactor	System input side	1) Improve input power factor; 2) Eliminate high-frequency harmonics in input side; protect the rectifier bridge. 3) Eliminate current unbalance due to input phase unbalance;
AC output reactor	Between output side of controller and motor, and near controller	Add AC output reactor if the distance between vector driver and motor is bigger than 100m .

3.3 Wiring terminal introduction

3.3.1 Control loop terminal layout shown below:

	PGA	PGB	PGZ	COM	DI1	DI2	DI3	DI4	COM	DI5	DI6	DI7	DI8	COM	+24V
MP24	MCOM	CAN+	CAN-	485+	485-	CZA1	GND								
TA1	TC1	TB1	TA2	TC2	TB2	TA3	TC3	TB3	\						

3.3.2 Drive loop terminal layout shown below:

	\	L1	L2			
P	PB					
U	V	W				

3.3.3 Control loop terminal description

Sort	Terminal label	Terminal function description	Technical specification
Communication (under research)	485+	MODBUS differential signal positive end	standard MODBUS communication interface STP recommended
	485-	MODBUS differential signal negative end	
	CAN+	CAN bus differential signal positive end	CAN bus communication interface STP recommended
	CAN-	CAN bus differential signal negative end	
Digit input	DI1~DI8	Digit signal input	1) Optocoupler isolation input. Low level valid 2) Input voltage range:DC9V~30V 3) Input impedance:3.3K
Inside 24V power	+24V	Outside connect 24V	1) Power supply of no-contact switch or coder disc 2) Max. output current 200mA
	COM	24V power common end	Isolated from inner GND
Encoder input	PGA	Encoder A phase	support collector open-loop output or push-pull output
	PGB	Encoder B phase	
	PGZ	Encoder Z signal	

Sort	Terminal label	Terminal function description	Technical specification
Analog input	CZA1	Weighing analog input	Input voltage range DC0V~10V
	GND		
External 24V power	MP24	External 24 v power supply	External power supply for communication and analog use
	MCOM	External power common end	
Relay output & shield grounded	TA1/TB1/TC1 TA2/TB2/TC2 TA3/TB3/TC3	Relay output	1) TA-TB:N.C;TA-TC:N.O.,Contact capability:250VAC/3A DC30V/1A 2) Contacts and control loop insulate voltage level:2.5kVAC

3.3.4 drive loop terminal description

Mark	Name	description
L1.L2	Single phase power input terminal	AC single phase 220Vinput terminal
P.PB	brake resistance connect terminal	brake resistance connection terminal of the controller
U.V.W	controller output drive terminal	Connect 3-phases motor
	GND terminal	GND terminal

3.4 Other interfaces

- 1) DB 9: Connect the inside car command board

Inside car command board is the accessory product of NICE series elevator controller; this function is under research now.

- 2) RJ 45: parameter copy and software maintaining

This function is still under research.



Door machine controller & Trial run

Chapter 4 Door machine controller & Trial run

4.1 Operation & display

Users can modify the function parameter, monitor the working state and control the operation panel running by the operation panel.

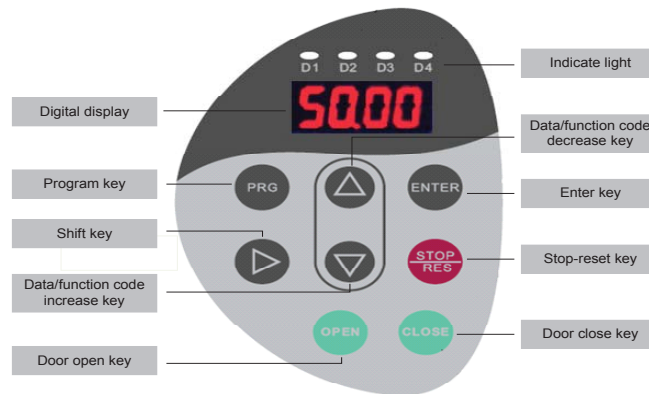

Fig 4-1 Operation panel display

Key	Name	Function
PRG	Program keys	The enter /out of 1st level menu ,quick parameter delete
ENTER	Enter key	Enter the menu by level ,parameter setting affirm
STOP/RES	Stop/reset	Running state :used for stop running Error alarm state: used for resetting.
▶	Shift	stop/run state: Cyclical selection of LED display parameter. (the modifying bit can be selected)
▲	Incremental key	The increase of data and parameter code
▼	Decrease key	Decrease of data and parameter code
OPEN	Open key	Open the door in panel operation mode.
CLOSE	Close key	Close the door in the panel operation mode.

4.2 The basic operation of controller.

4.2.1 Operation flow of 3-level menu.

NICE900 adopts 3-level menu to conduct the parameter setting. It's convenient to query and modify function code and parameter.

3-level menu include: function parameter group (first level) → function code (second level) → function code setting (third level). You can refer to operation flow chart Fig4-2.

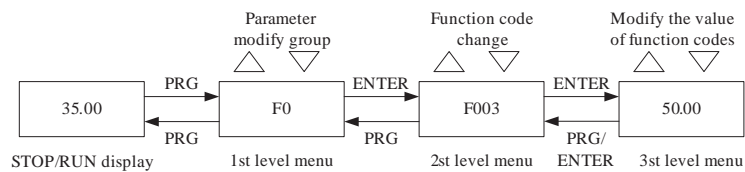

Fig 4-2 operation flow chart of 3level menu

Note: when in 3rd menu, system can be backed to 2nd menu by pressing “PRG” or “ENTER”. The difference between them: it goes back to 2th menu with parameter saved when pressing “ENTER”, then jump to next function code automatically; while it back to the 2nd menu with the parameter unsaved and it will stay in the current function code.

Example: change F0-04 from 00.00Hz to 15.00Hz (boldfaced words means flash bit)

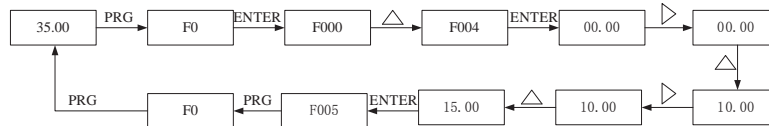

Fig 4-3 parameter editing operation process

In 3-level menu, if the parameter has no flash bit, it means the function code cannot be changed and the possible reasons are:

- 1) This function code is un-revisable, such as the actual examine parameter and running record parameter..
- 2) This function code cannot be changed in operating state and can only be changed when the controller is stopped.

4.2.2 Error information reading

When error occurs, the error code will be displayed on panel. It is convenient to find reason of error and get rid of the error as soon as possible.

NICE2000 controller can save the previous 4 error codes and record the last error frequency, current, bus voltage, digit input terminal state and digit output terminal state. The relative sketch map is listed below:

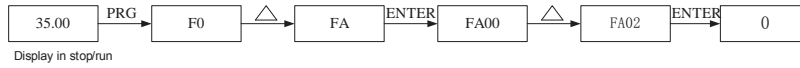

Fig 4-4 error information reading

4.2.3 Examine the run/stop display information

If the controller is in run/stop state and no error occurs, the run/stop display parameter can be examined by the setting of FA00/FA01 and shift key.

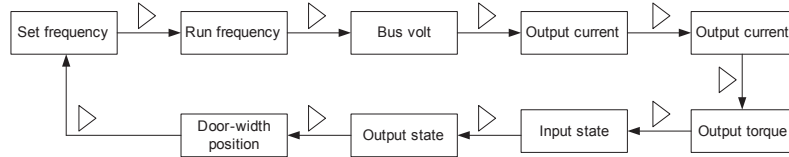

Fig 4-5 Run parameter display

4.2.4 Password setting

In order to protect the parameter more effectively, NICE900 provides the password protection.

The figure below shows how to set the password to 12345.

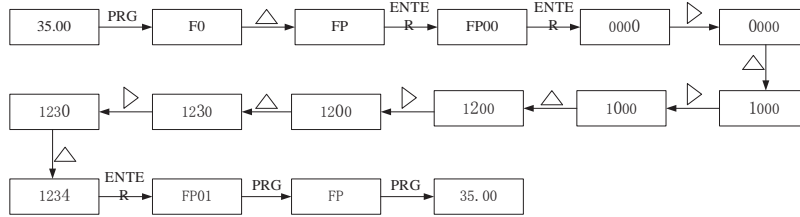

Fig 4-6 process of password setting

After setting the function password (parameter FP.00 is not zero), if the user presses “PRG”, the controller will enter into password validate state first and display“-----”. User can only enter the menu after inputting the user password. For factory setting parameters editing, the user still need to input the factory password. (Warning: do not change the factory setting parameter; if the parameter values are wrong, the controller will work abnormally, even be damaged.)

When the password protection is unlocked, user can change the password freely, and the last input will be the user password.

If the user wants to cancel the password protection function, enter after inputting the password and setting FP.00 as 0; if FP.00 is not zero, the parameter is password protected.



Function parameter table

Chapter 5 Function parameter table

5.1 function parameter table

Function parameters are classified into 13 groups. Each group has several function codes. The function code uses 3-level menu with the format "F X-XX", which means "No. XX function code in group X". For example, F 3-02 means the No.2 function code in group F3.

In order to make functional code setting convenient, the function group number corresponds to first level menu, the function code number corresponds to second level menu, and function code parameters correspond to third level menu.

The contents of function codes:

Column 1"function code", means the serial number for function parameter group and parameter;

Column 2"name", means the complete name of the function parameter;

Column 3"setting range", means the parameter setting range;

Column 4"minimum unit", means the minimum unit of the parameter setting;

Column 5"factory setting", means the original default;

Column 6"operation", means the modification attributes of the parameters (whether to enable the modification and the modification requirements).

Instructions are listed below:

☆: the parameter can be modified while the controller is running or stopping;

★: the parameter can not be modified while the controller is running;

●: the parameter cannot be modified for it is actually measured and recorded.

"Factory Default" means the numeric value after the function code parameter is refreshed when recovering the default parameter, but the actually measured value or recorded value will not be refreshed.

The controller provides password protection of function code to protect the parameters effectively (detailed in Chapter 4).

5.2 function table

Press PRG buttons and then UP/DOWN button, all of the displays are first level menu, which are group of function. Details as follows:

5.2.1 Grouped into menus

F0- Basic function parameter

F1- Motor parameter

F2- Performance control parameter

F3- Open door run parameter

F4- Close door run parameter

F5- Open/Close door auxiliary parameter

F6- Distance control parameter

F7- Demonstrating function parameter

F8- Auxiliary parameter

F9- I/O terminal function parameter

FA- Display & Error parameter

FF- Factory parameter

FP- User parameter

5.2.2 Function specification

Notice: The default parameter of some sync motor may different from the table listed below, please so details in the end of chapter 5.

Function code	Name	Setting range	Min.unit	default	Change properties
F0- basic function parameter					
F000	Control mode	0:Magnetic flux vector control 1:close-loop vector control	1	0	★
F001	Open/close door mode selection	0:speed control 1:distance control	1	0	★
F002	Command source selection	0:operation panel control mode 1:door machine terminal control mode 2:door machine manual adjusting mode 3:door machine auto demonstrating mode	1	0	★
F003	Max. freq	20.00Hz~99.00Hz	0.01Hz	50.00Hz	★
F004	Panel setting freq.	0.00Hz~F003	0.01Hz	5.00Hz	☆
F005	Operation direction setting	0:same as set direction 1:opposite to set direction	1	0	★
F006	Slow walking speed setting	0.00~20.00Hz	0.01Hz	4.00Hz	★
F007	Carrier wave freq. setting	2.0kHz~16.0kHz	0.1kHz	8.0kHz	★

Function code	Name	Setting range	Min.unit	default	Change properties
F1- motor parameter					
F100	Motor type selection	0:asynchronous motor 1:sync motor	1	0	★
F101	Motor rated power	0~750W	1W	Model determined	★
F102	Motor rated voltage	0~250V	1V	Model determined	★
F103	Motor rated current	0.10A~99.00A	0.01A		★
F104	Motor rated freq.	1.00Hz~99.00Hz	0.01Hz	Model determined	★
F105	Motor rated rotation speed	1~9999rpm	1rpm	Model determined	★
F106	Stator phase resistance	00.00~99.99Ω	0.01	Model determined	★
F107	Asynchronous motor rotor phase resistance	00.00~99.99Ω	0.01	Model determined	★
F108	Asynchronous motor leakage inductance	0~99.99mH	0.01mH	Model determined	★
F109	Asynchronous motor mutual inductance	0~999.9mH	0.1mH	Model determined	★
F110	Asynchronous motor non-load excitation current	0.00~99.99A	0.01A	Model determined	★
F111	Sync motor D-axis inductance	0~999.9mH	0.1mH	Model determined	★
F112	Sync motor Q-axis inductance	0~999.9mH	0.1mH	Model determined	★
F113	Sync motor inverse-EMF coefficient	0~250	1	Model determined	★
F114	sync motor coder zero position	0~359.9	0.1	Model determined	★
F115	Actual angle of sync motor	0~359.9	0.1	Model determined	●
F116	Motor auto-tuning	0~5	1	0	★

Function code	Name	Setting range	Min.unit	default	Change properties
F2- performance control parameter					
F200	Speed loop proportional gain 1	0~100	1	30	☆
F201	Speed loop integration time 1	0.01~10.00s	0.01s	0.50s	☆
F202	Switching freq.1	0.00~F205	0.01Hz	5.00Hz	☆
F203	Speed loop proportional gain 2	0~100	1	20	☆
F204	Speed loop integration time 2	0.01~10.00s	0.01s	1.00s	☆
F205	Switching freq.2	F202~F003	0.01Hz	10.00Hz	☆
F206	Current loop proportional gain	10~500	1	60	☆
F207	Current loop integral gain	10~500	1	30	☆
F208	Slip compensation coefficient	50%~200%	1%	100%	☆
F209	Torque hoist	0~30.0%	0.1%	1.0%	☆
F210	Over-excitation gain	0~200	1	64	☆
F211	Sync machine initial position interference mode	0~2	1	1	★
F212	Speed feedback filtering level	0~20	1	0	☆
F213	Pulse encoder pulse setting	1~9999	1	2048	★
F214	Pulse encoder direction selection	0:forward 1:reversal	1	0	★
F215	Pulse encoder direction selection	0:forward 1:reversal	1	0	★
F3- open-door run parameter					
F300	Open door startup low speed setting	0.00~F303	0.01Hz	6.00Hz	☆

Function code	Name	Setting range	Min.unit	default	Change properties
F301	Open door startup acceleration time	0.1~999.9s	0.1s	1.0s	☆
F302	Speed control open door startup low speed run time	0.1~999.9s	0.1s	1.0s	☆
F303	Open door freq. setting	0.00Hz~F003	0.01Hz	25.00Hz	☆
F304	Open door acceleration time	0.1~999.9s	0.1s	2.0s	☆
F305	Open door end low speed setting	0.00~F303	0.01Hz	3.00Hz	☆
F306	Open door deceleration time	0.1~999.9s	0.1s	2.0s	☆
F307	Open door locked-rotor to torque holding switch point setting	0.0%~150.0% motor rated torque	0.1%	50.0%	★
F308	Open door arrival torque holding	0.0%~F307	0.1%	50.0%	★
F309	Door-open blocked torque	0.0%~150.0% rated torque	0.1%	80.0%	☆
F310	Door-open startup torque	0.0%~150.0% rated torque	0.1%	0.0%	★
F311	Door-open blocked judging time	0~9999ms	1ms	0ms	☆
F4-close-door run parameter					
F400	Close-door startup low speed setting	0.00Hz~F403	0.01Hz	4.00Hz	☆
F401	Door-closing start acceleration time	0.1~999.9s	0.1s	1.0s	☆
F402	Speed control door-closing start low-speed run time	0.1~999.9s	0.1s	1.0s	☆
F403	Door-closing high-speed setting	0.00Hz~F104	0.01Hz	12.00Hz	☆
F404	Door-closing acceleration time	0.1~999.9s	0.1s	2.0s	☆

Function code	Name	Setting range	Min.unit	default	Change properties
F405	Door-closing end low-speed setting	0.00Hz~F403	0.01Hz	2.00Hz	☆
F406	Door-closing deceleration time	0.1~999.9s	0.1s	1.5s	☆
F407	Door-closing low-speed setting	0.00Hz~F403	0.01Hz	1.00Hz	☆
F408	Door-closing low-speed run time	1~9999ms	1ms	300ms	☆
F409	Skate withdraw speed setting	0.00Hz~F403	0.01Hz	2.00Hz	☆
F410	Skate withdraw run time	1~9999ms	1ms	500ms	☆
F411	Door-closing torque switching-point setting	0.0%~150.0% rated torque	0.1%	50.0%	☆
F412	Close door arrival torque holding	0.0%~F411	0.1%	30.0%	☆
F413	Door-closing blocked torque	0.0~150.0%	0.1	100.0	★
F414	closed blocked working mode	0~1 0:stop when blocked in door-closing 1:re-start when blocked in door-closing	1	1	★
F415	Door-closing blocked judging time	0~9999ms	1ms	500ms	☆
F416	Fire emergency closing high speed setting	5.00Hz~F104	0.01Hz	10.00Hz	☆
F417	Door-close hi-speed setting	F418~F104	0.01Hz	12.00Hz	☆
F419	Door-close blocked low-speed setting	0.00Hz~F104	0.01Hz	2.00Hz	☆
F419	High-speed blocked torque setting	0.0%~150.0%	0.1%	100.0%	☆
F420	Low-speed blocked torque setting	0.0%~150.0%	0.1%	100.0%	☆

Function code	Name	Setting range	Min.unit	default	Change properties
F5-open/close door auxiliary parameter					
F500	Abnormal deceleration time	0.1~5.0s	0.1	0.3s	☆
F501	Door open time limit	0~999.9s	0.1s	0.0s	☆
F502	Door closing time limit	0~999.9s	0.1s	0.0s	☆
F503	Slow speed run time limit	0~999.9s	0.1s	0.0s	☆
F504	External open command delay time	0~999.9s	0.1s	0.0s	☆
F505	External close command delay time	0~999.9s	0.1s	0.0s	☆
F506	Door-open curve selection	0~1 0:straight line acceleration/ deceleration 1:S curve acceleration/ deceleration	1	1	★
F507	Open-door acceleration S curve initial time	10.0%~50.0% (acceleration/ deceleration time) (initial stage+ascend stage≤90%)	0.1%	20.0%	★
F508	Open-door acceleration S curve hoist time	10.0%~80.0% (acceleration/ deceleration time) (initial stage+ascend stage≤90.0%)	0.1%	60.0%	★
F509	Open-door deceleration S curve initial stage time	10.0%~50.0% (acceleration/ deceleration time) (initial stage+ascend stage≤90%)	0.1%	20.0%	★
F510	Open-door deceleration S curve descend stage time	10.0%~80.0% (acceleration/ deceleration time) (initial stage+descend stage≤90%)	0.1%	60.0%	★
F511	Close door curve selection	0~1 0:straight line 1:S curve acceleration/ deceleration	1	1	★

Function code	Name	Setting range	Min.unit	default	Change properties
F512	Close door acceleration S curve initial stage time	10.0%~50.0% (acceleration/ deceleration time) initial stage+ascend stage 90%	0.1%	20.0%	★
F513	close door acceleration S curve ascend stage time	10.0%~80.0% (acceleration/ deceleration time) initial stage+ascend stage 90%	0.1%	60.0%	★
F514	close door deceleration S curve initial stage time	10.0%~50.0% (acceleration/ deceleration time) initial stage+descend stage 90%	0.1%	20.0%	★
F515	close door deceleration S curve descend stage time	10.0%~80.0% (acceleration/ deceleration time) initial stage+descend stage 90%	0.1%	60.0%	★
F516	Speed bias setting	0~80%	1%	50%	☆
F517	Judging time when the speed bias is huge	0~5000ms	1ms	400ms	☆
F518	Door-closing constant speed delay time	0~9999ms	1ms	200ms	★
F6-distance control parameter					
F600	Door width auto-tuning function selection	0~1 0:invalid 1:door width measuring,, valid only in manual adjusting mode	1	0	★
F601	Door width auto-tuning speed	0~20.00Hz	0.01Hz	3.00Hz	★
F602	Door width pulse amount low bit	0~9999	1	0	★
F603	Door width pulse amount high bit	0~9999	1	0	★
F604	Distance control open startup low speed run	0~30.0% door width	0.0%	15.0%	☆

Function code	Name	Setting range	Min.unit	default	Change properties
F605	Distance control open-door deceleration point setting	60.0%~90.0% (door width)	0.1%	70.0%	☆
F606	distance control open-door limit point setting	80.0%~99.0% (door-width)	0.1%	96.0%	☆
F607	Distance control close-door startup low speed run distance	0.0%~30.0% (width)	0.1%	10.0%	☆
F608	Distance control close-door deceleration point setting	60.0%~90.0% (width)	0.1%	70.0%	☆
F609	Distance control close-door limit point setting	80.0%~99.0% (width)	0.1%	96.0%	☆
F611	Low-bit of door-open limit switch	0~9999	0	0	★
F612	Low-bit of door-open limit switch	0~9999	0	0	★
F613	Swotch position of the door-closing	0~9999	0	0	★
F614	Door-width auto-tuning and initialation run torque setting	0.0~150.0%	0.1%	80.0%	★
F615	Pulse low-bit of the door-open deceleration point	0~9999	0	0	★
F616	Pulse high-bit of the door-open deceleration point	0~9999	0	0	★
F617	Pulse low-bit of the door-closing deceleration point	0~9999	0	0	★
F618	Pulse high-bit of the door-closing deceleration point	0~9999	0	0	★

Function code	Name	Setting range	Min.unit	default	Change properties
F619	Door-width setting when door-open limit	0~99.9%	0.1%	0	☆
F620	Door-width setting when door-closing limit	0~99.9%	0.1%	0	☆
F7-Demonstrating function parameter					
F700	Demonstrate open arrival holding time	1.0~999.9s	0.1s	2.0s	☆
F701	Demonstrate close arrival holding time	1.0~999.9s	0.1s	2.0s	☆
F702	Demonstrate close/open times record.	0~9999	1	0	★
F703	Demonstrate open/close specify run times	0~9999	1	0	★
F8-auxiliary parameter					
F800	Software version number	0.00~99.00	0.01	1.00	●
F801	Module temperature	0~100℃	1℃	0	●
F802	Error auto reset times	0~100 0 no auto reset function (gap is 2s),circulation is 1 hour	1	0	★
F803	Brake utilization ratio	0~100%	1	100	☆
F804	Accumulative working time	0~9999 hours	1	0	★
F805	reserved (minute)	0	1	0	★
F806	Accumulative run time	0~9999 hours	1	0	★
F807	Reserved (minute)	0	1	0	★
F808	Accumulative run time setting	0~9999 hours	1	0	★
F809	Accumulative run time setting	0~9999 hours	1	0	★

Function code	Name	Setting range	Min.unit	default	Change properties
F810	Error function selection	0~9999	1	0	☆
F811	Error function select	0~9999	1	0	★
F812	Drive function select	0~9999	1	0	★
F814	Overload factor	0~10.00	0.01	1.00	☆
F816	Door-operator amount	1~2	1	1	★
F9-I/O function parameter					
F900	terminal filtering time	0~100ms	1ms	20ms	☆

Function code	Name	Setting range	Min.unit	default	Change properties
F901	Switch input terminal DI1	0 no function can be re-selected 1 open command	1	0	★
F902	Switch input terminal DI2	2 close command 3 external RESET input 4 open forbidden	1	0	★
F903	Switch input terminal DI3	terminal input 5 torque holding forbid terminal input	1	0	★
F904	Switch input terminal DI4	6 low speed open/close enable input 7 fire input	1	0	★
F905	Switch input terminal DI5	8~9 reserved 10 light curtain N.O input 11 touch-pad signal	1	0	★
F906	Switch input terminal DI6	N.O input 12 open limit signal N.O. input	1	0	★
F907	Switch input terminal DI7	13 close limit signal N.O. input 14 open-door deceleration point N.O input	1	0	★
F908	Switch input terminal DI8	15 close-door deceleration point N.O input 16 door lock signal N.O input 17~109 reserved 110 light curtain N.C input 111 touch pad signal N.C input 112 open limit signal N.C input 113 close limit signal N.C input 114 open-door deceleration point N.C input 115 close-door deceleration N.C input 116 door lock signal N.C input	1	0	★

Function code	Name	Setting range	Min.unit	default	Change properties
F909	Programmable relay output TA1/TB1/TC1	0 no function 1 open arrival signal output 0 2 close arrival signal	1	4	★
F910	Programmable relay output TA2/TB2/TC2	output 0 3 open arrival signal output 1 4 close arrival signal	1	0	★
F911	Programmable relay output TA3/TB3/TC3	output 1 5 error relay signal output1 6 reserved 7 open arrival signal output 2 8 close arrival signal output 2 9 door lock signal output 10 re-open door signal output 11 blocked signal output	1	3	★
FA-display & error parameter					
FA00	LED run display parameter selection	Adopt binary code =1 select BIT0 freq. setting Hz BIT1 run freq. Hz BIT2 Dc bus voltage V BIT3 output voltage V BIT4 output current A BIT5 output torque % BIT6 switch input terminal state BIT7 switch output terminal state BIT8 door width pulse percentage Remark: every monitor amount that selected by FA00 can be displayed during operation and switched by SHIFT key. 1~511	1	319	☆

Function code	Name	Setting range	Min.unit	default	Change properties
FA01	LED machine-stop display parameter selection	0 open-door setting freq. Hz 1 close-door setting freq. Hz 2 DC bus voltage V 3 switch input terminal state 4 switch output terminal state 4 door width pulse percentage Remark: every monitor amount that selected by FA01 can be displayed during operation and switched by SHIFT key. 1~63	1	39	☆

Function code	Name	Setting range	Min.unit	default	Change properties
FA02	First error type	0 no abnormal record clear	1	0	●
FA03	First error reminding	abnormal record 1 reserved	1	0	●
FA04	Second error type	2 acceleration running over-current Er02	1	0	●
FA05	Second error reminding	3 deceleration running over-current Er03	1	0	●
FA06	Third error type	4 constant speed running over-current Er04	1	0	●
FA07	Third error reminding	5 acceleration running over-voltage Er05	1	0	●
FA08	4th error type	6 deceleration running over-voltage Er06	1	0	●
FA09	4th error reminding	7 constant speed running over-voltage Er07	1	0	●
FA10	Last error type	8~9 reserved 10 controller overload Er10	1	0	●
FA11	5th error reminding	11~12 reserved 13 output phase-failure Er13 14 radiator overheated Er14 15 reserved 16 EEPROM read-write errorsEr16 17 reserved 18 current check circuit error Er18 19 tuning overtime error Er19 20 speed feedback error Er20 21 initial position check error Er21 22~24 reserved 25 over-speed error Er25 26 parameter setting error reminding Er26 27 door width auto-tuning error Er27 28 open overtime Er28 29 close overtime Er29 30 low speed open/close overtime error Er30	1	0	●

Function code	Name	Setting range	Min.unit	default	Change properties
FA12	Last error bus voltage	0~999.9V	0.1V	0.0V	●
FA13	Last error output current	0.00~99.99A	0.01A	0.00A	●
FA14	Last error run freq.	0.00Hz~99.00Hz	0.01Hz	0.00Hz	●
FA15	Last error output torque	0.0~180.0%	0.1%	0.0%	●
FA16	Last error input terminal state	0~1023 0:OFF 1:ON DI8/DI7/DI6/DI5/DI4/DI3/DI2/ DI1	1	0	●
FA17	Last error output terminal state	0~15 0:OFF 1:ON T1/T2/T3	1	0	●
FA18	Terminal state query	*	*	*	●
FA19	Function input state query	*	*	*	●
FA20	Function output state query	*	*	*	●
FA21	Display switch control	0~9999	1	0	☆
FA22	Display 1	0~9999	1	0	●
FA23	Display 2	0~9999	1	0	●
FA24	Analog voltage display	0.00~10.10V	0.01V	0.00V	●
FF-factory parameter (reserved)					
FF-00	reserved	0	1	0	●
FP- user parameter					
FP-00	User password	0~9999 (0 means no password)	1	0	☆
FP-01	Parameter update	0:non 1:to restore the factory parameter 2:delete memory information	1	0	★

Remark : The different parameter are listed below:

Function code	Name	Setting range	Min. unit	default	Change properties
F0- basic parameter					
F000	Control mode	0:magnetic flux vector control 1:close-loop vector control	1	1	★
F001	Open/close mode selection	0:speed control mode 1:distance control mode	1	1	★
F003	Max. freq.	20.00Hz~99.00Hz	0.01Hz	24.00Hz	★
F3-open-door run parameter					
F300	open-door startup low speed setting	0.00~F303	0.01Hz	5.00Hz	☆
F303	open door freq. setting	0.00~F003	0.01Hz	15.00Hz	☆
F4-close-door run parameter					
F400	Door-close startup low speed setting	0.00~F403	0.01Hz	4.00Hz	☆
F403	Door-close freq. setting	0.00~F003	0.01Hz	12.00Hz	☆



Function parameter specification

Chapter 6 Function parameter specification

6.1 F0 Basic function parameter

F000	Control mode	default	0	Min. unit	1
	Setting range	0~1			

0: optimizing V/F control

It is suitable for the general application case, in which the motor do not need to be connected to the rotating coder. The control effect will be a little bit worse than vector control. The magnetic flux vector control can never be applied to the case of permanent magnetism sync motor drive.

1: close-loop vector control

Feedback the motor speed signal by the encoder, the controller will run with vector mode. The encoder and motor must be connected with the same axis and the encoder wire amount must be correctly set.

F001	Close/open mode selection	Default	0	Min. unit	1
	Setting range	0~1			

0:Speed control mode

This mode need to install 4 switches on the door, and slowdown by the deceleration point, disposal the arrival by the limit switch signal.

1: Distance control mode

In this mode, the door width pulse auto-tuning must be correct. By setting the open/close curve parameter to slowdown or reach arrival (if the limit signal has been set at the F9 input terminal function selection part, then it will dispose the arrival by the limit signal.)

F002	Command source selection	Default	0	Min. unit	1
	Setting range	0~3			

0: Operation panel control mode

Control running /stop by the operation panel, co-rotation by pressing the OPEN key, inversion by pressing the CLOSE key, and stop by pressing the STOP/RESET keys. In this mode, the controller will not operate door-machine special logic flow.

1: Door-machine terminal control mode

The controller manages the door open/close by the system signal. The operation logic is listed below:

Open command	Close command	Operation state
0	0	Stop
0	1	Close

Open command	Close command	Operation state
1	0	Open
1	1	Open

Table 6-1The logic table

2: Door machine manual adjusting mode

Control running /stop by the operation panel, door open by pressing the OPEN key, door closed by pressing the CLOSE key, and stop by pressing the STOP/RESET keys

3: Door machine auto-demonstrating mode

This mode is applied to door-machine demonstrating or factory trial run which need no control system's participation. The mode can be set after adjusting the door machine running curve. The demonstrating of open/close can be repeat by pressing OPEN or CLOSE key. The time gap can be modified by F7 parameters, the machine stop by pressing STOP/RESET key.

Remark:

- 1) Door width auto-tuning only valid in the door machine manual adjusting mode.
- 2) Motor tuning only valid in the panel control mode.

F003	Max. freq.	Default	50.00Hz	Min. unit	0.01Hz
	Setting range	20.00~99.00Hz			

Used to set the controller Max. freq.

F004	Panel run freq.	Default	0.00Hz	Min. unit	0.01Hz
	Setting range	0.00~max. freq. (F002)			

Speed setting mode adopts the running target freq. in the panel control mode.

F005	Run direction setting	Default	0	Min. unit	1
	Setting range	0~1			

By changing this function code, the tractor running direction can be altered without the change of wiring.

P.S.: parameter initialization will make the motor run direction w back to the original state .user must cautious about this parameter.

F006	Slow walking speed setting	Default	4.00Hz	Min. unit	0.01Hz
	setting range	0~1			

Door-open mode selection (F001) is the first run freq. of the distance control and door walking speed when the slow open/close signal enable is valid.

F007	Carrier wave freq.	Default	8.0kHz	Min. unit	0.1kHz
	Setting range	2.0~16.0kHz			

This function adjusts inverter carrier wave freq. to reduce the motor noise, the current leakage and inverter interference.

When the carrier frequency is low, the output current higher-harmonic component increases, the consumption and temperature rise of the motor increase as well.

When the carrier frequency is high, the motor consumption declines and the motor temperature rise reduces, but the consumption, temperature rise and interference of the system increase.

Carrier wave freq.	low ~ high
Motor noise	big ~ small
Output current wave	Bad ~ good
Motor temperature rise	high ~ low
Inverter temperature rise	low ~ high
Leakage current	Small ~ big
External radiation interference	Small ~ big

Table 6-2 Relevant parameter of carrier wave freq.

6.2 F1- motor parameter

Function code	Name	Default	Min. unit	Setting range
F100	Motor type selection	0	1	0~2
F101	Rated power	Models to determine	1W	0~750W
F102	Rated voltage	220V	1V	0~250V
F103	Rated current	Models to determine	0.01A	0.10~9.90A
F104	Rated freq.	50.00Hz	0.01Hz	1.00~99.00Hz
F105	Rated rotation rate	1460rpm	1rpm	0~9999rpm

Please set the parameter according to the motor nameplate

Function code	Name	Default	Min. unit	Setting range
F106	Stator resistance	Models to determine	0.01Ω	0.00~99.99Ω
F107	Rotor resistance	Models to determine	0.01Ω	0.00~99.99Ω
F108	Leakage inductance	Models to determine	0.01mH	0.0~99.99mH

Function code	Name	Default	Min. unit	Setting range
F109	Mutual inductance	Models to determine	0.1mH	0~999.9mH
F110	Non-load current	Models to determine	0.01A	0.01~99.99A
F111	D-axis inductance	Models to determine	0.1mH	0.0~999.9mH
F112	Q-axis inductance	Models to determine	0.1mH	0.0~999.9mH
F113	Opposing electromotive force	Models to determine	1V	0~250V
F114	Encoder zero position	Models to determine	0.1	0.0~359.9
F115	Actual angle of sync motor	Models to determine	0.1	0.0~359.9

F106~ F110 will update automatically after the motor auto-tuning.

About asynchronous machine; the NICE 900 controller can obtain the above parameters through the complete tuning or static tuning. If the spot tuning can not be done, users can manually input it (refers to the same nameplate parameter). The system will resume the standard motor parameter of F106-F110, every time after modification of rated power F101.

Applied to permanent-magnet sync motor: The system can obtain parameter of F106, F111, F112, F113, F114. The corresponding parameter will not be updated after the modification of rated power F101.

F116	Motor tuning		Default	0	Min. unit	1
	Setting range	0~5 (asynchronous :1.2.5 sync :3.4.5)				

The motor tuning must in the panel control mode (F002 = 0). Before the tuning ,motor rated parameter (F100 – F105) and encoder wiring parameter F6-00.

0: Non

1: Asynchronous motor static tuning

Applied when the complete tuning can not be down to tune the stator resistance, rotor resistance and leakage inductance parameter (non-load current and mutual inductance should be calculated)

2: Asynchronous machine complete tuning

in order to assure the controller dynamic control performance, please select the complete tuning. The motor must be in non-load state in complete tuning.

After select complete tuning , controller do the static tuning first, then the motor will accelerate to the 80% of the rated freq with the default time 2s. then hold on for a period , then decelerate to zero with the rated slowdown time 2s. to over the complete tuning process.

3: permanent magnet sync motor non-load tuning.

Including: encoder zero compensation angle (F114), stator resistance (F106), dq –axis inductance (F110.F111) e.g. The motor must in non-load state to assure the control performance.

4: permanent magnet sync motor loaded tuning

Including: encoder zero compensation angle (F114), stator resistance (F106), dq –axis inductance (F110.F111) e.g.. please manage to use non-load tuning to assure the accuracy

5: Inertia tuning (under research)

Tuning operation:

Pressing ENTER key after setting F116, then the “TUNE” displayed and flash, pressing “CLOSE” or “OPEN” to start parameter tuning ,the “TUNE” will stop flash. The tuning can also be stopped by pressing STOP key.

The F116 will resume to 0 when the tuning is over.

Remark: please do the motor tuning before the 1st run of the permanent magnet sync motor, pay attentions to the blocked-rotor to assure the success of the tuning.

Please refer to chapter 7 for the use of permanent magnet sync motor.

6.3 F2 Performance control parameter

F200	Speed-loop proportional gain 1	Default	30	Min. unit	1
	Setting range	0~100			
F201	Speed-loop integral time 1	Default	0.50s	Min. unit	0.01s
	Setting range	0.01~10.00s			
F202	Switch freq. 1	Default	5.00Hz	Min. unit	0.01Hz
	Setting range	0.00~F205 (switch freq. 2)			
F203	Speed-loop proportional gain 2	Default	20	Min. unit	1
	Setting range	0~100			
F204	Speed-loop integral time 2	Default	1.00s	Min. unit	0.01s
	Setting range	0.01~10.00s			
F205	Switch freq. 2	Default	30	Min. unit	1
	Setting range	F202 (switch freq. 1) ~F003 (max. freq)			

F200 and F201 are PI adjusting parameter when the running freq. is smaller than switch freq.; F203 and F204 are PI adjusting parameter when the running freq. is bigger than switch freq. The PI adjusting parameter between switch freq. 1 and 2 is the weighted average of

F200, F201 and F203, F204. See the fig below for details.

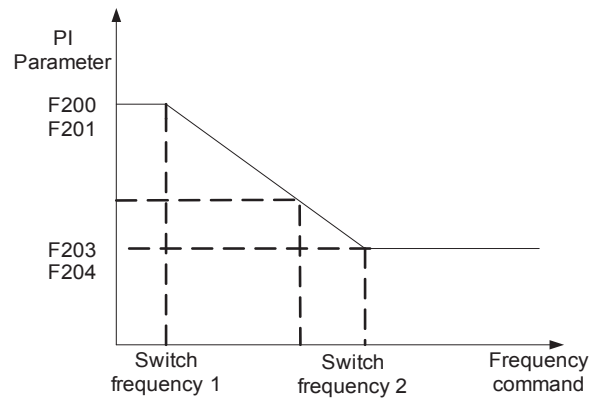

Fig 6-1 PI parameter

The vector control speed dynamic response characteristic can be adjusted by the means of adjusting proportional coefficient and integral time of speed adjustor. Increase of proportional gain and decrease of integral time both can quicken speed-loop dynamic response. The over-increase of proportional gain or over-small of integral time may cause surge of system.

Recommended adjusting method:

fine tune the default parameter if it is not suitable for the application: increase the proportional gain to avoid system surge then decrease the integral time to insure the quick response of system.

If both the switch freq. 1 and 2 are zero, only the F203 and F204 are valid.

Remark: The inappropriate setting of PI parameter may cause overshoot of speed, even over-voltage error.

F206	Current-loop proportional gain	Default	60	Min. unit	1
	Setting range	10~500			
F207	Current-loop integral gain	Default	30	Min. unit	1
	Setting range	10~500			

F206 F207 are current-loop adjusting parameter in the vector control arithmetic, generally need no adjusting. Please refer to the speed-loop adjustor if adjusting is needed.

F208	slip compensation coefficient	Default	100%	Min. unit	1%
	Setting range	50~200%			

This parameter influence the dynamic performance and load current of motor and it only be used when there is speed sensor vector control. Generally, it need no adjusting.

F209	Torque magnification	Default	1.0%	Min. unit	0.1%
	Setting range	0.0~30.0%			

In order to compensate the V/F control low frequency torque characteristic, some lifting compensation of the inverter output current are added.

If torque hoist is set too large, it may cause over-heated motor and over-current. Normally, do not set torque lifting over 8%

To adjust this parameter effectively can avoid over-current at startup of motor. As to the situation of over-load, it is recommended to increase this parameter; vice versa.

When the torque hoist is set to 0, controller become automatic torque rising

F210	over-excitation gain	Default	64	Min. unit	1
	Setting range	0~200			

The function of over-excitation gain is to restrain the bus voltage rising in the process of inverter deceleration. The bigger the over-excitation is the strong restrain effect will be.

- 1) Set as zero in small inertia condition, and set it bigger when inertia becomes bigger.
- 2) Remember to set it as zero in the case of brake resistance.

F211	Initial position inference method	Default	1	Min. unit	1
	Setting range	0~2			

1:Magnetic pole initial position inference method of permanent magnet sync motor which adopts pulse mode

2:Magnetic pole initial position inference method of permanent magnet sync motor which adopts other mode (under research)

F212	Feedback speed filtering level	Default	0	Min. unit	1
	Setting range	0~20			

This parameter set the encoder feedback speed filtering level. Generally, it needs no adjusting.

In the case of serious interference or very little encoder lines, if adopt close-loop vector control mode, the feedback speed filtering level should be added to insure the smooth run of motor.

Remark: in the case of small load, too big parameter setting may cause serious motor overshoot or surge.

F213	Encoder pulse setting	Default	2048	Min. unit	1
	Setting range	1~9999			

If the NICE 900 controller need to close-loop vector run, the encoder parameter must be correctly set. In the door machine distance control mode, the encoder parameters are also need to be correctly set to insure the good effect of distance control.

F314	Encoder direction selection	Default	0	Min. unit	1
	Setting range	0~1			

This parameter will back to zero when restore factory setting, please cautious about this function.

6.4 F3 – open-door run parameter.

In the speed-control mode, door machine signal contacts (travel switch) install position show below:

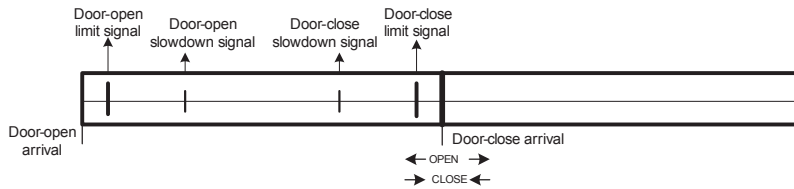

Fig 6-2 speed control switch install sketch

Correctly set the parameter in F3 group which related to speed control, precisely set slowdown signal switch and limit signal switch, open-door run speed curve can be detailed as fig 6-3.

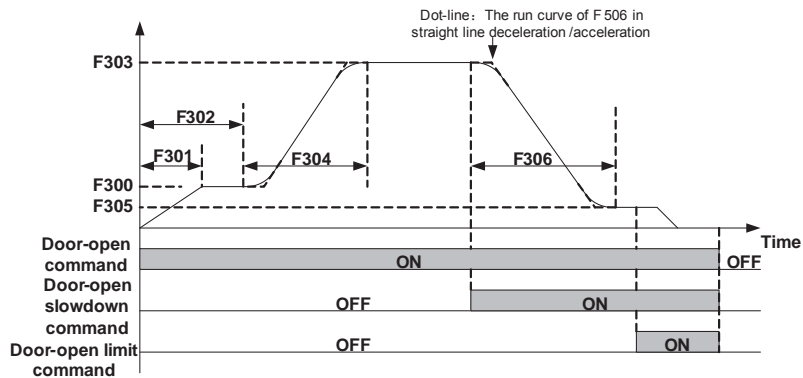

Fig 6-3 Speed control open-door curve sketch

Speed control door opening process:

- 1) When the door opening command is valid, door machine accelerate to F300 creeping speed then run at constant speed in the door open low speed stage.
- 2) Time from door open starting, when the time reaches low speed run time (F302), then door machine switch to high speed (F303), and speedup at F304 time, then constant run in the high speed stage.
- 3) When the door open signal is valid, door machine set F305 as target speed, slowdown

with F306 time, when the deceleration is over then run at constant speed in the door open finish low speed stage.

- 4) When the door open limit signal is valid, door machine continue to creeping at door open finish low speed, after locked-rotor, entering door opening torque holding state, holding torque as F308,a complete door open process is over.
- 5) When the open command is invalid, open torque holding is over.
- 6) Dotted line display: running curve When the door opening curve selection (F506) is straight line acceleration/slowdown.

Correctly set parameter in F3 group which related to distance control, set relevant pulses, the door opening speed curve can be detailed as fig 6-4.

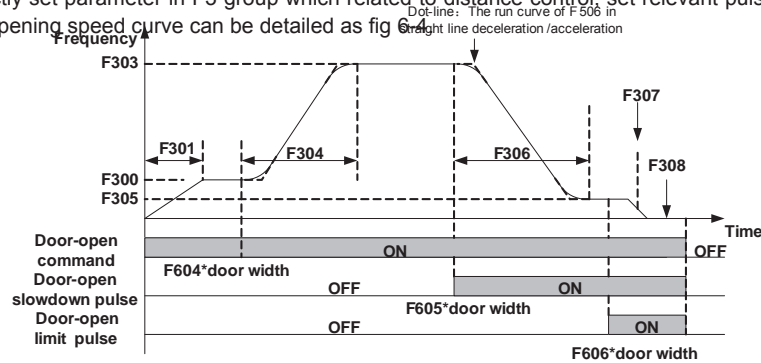

Fig 6-4 Distance control open-door curve sketch

Distance control door opening process:

- 1) When the door opening command is valid, door machine accelerate to F300 creeping speed then run at constant speed in the door open low speed stage.
- 2) When the door-opening distance reaches F604*door width,then door machine switch to high speed (F303), and speedup at F304 time, then constant run in the high speed stage.
- 3) When the door-opening distance reaches F605*door width,door machine set F305 as target speed, slowdown with F306 time, when the deceleration is over then run at constant speed in the door open finish low speed stage.
- 4) When door opening distance pulse reaches (door width-F606),door machine continue to creeping at door open finish low speed, after locked-rotor, entering door opening torque holding state, holding torque as F308,a complete door open process is over.
- 5) When the open command is invalid, open torque holding is over.
- 6) Dotted line display: running curve when the door opening curve selection (F506) is straight line acceleration/slowdown.

F307	Open door locked-rotor to torque holding switch point setting	Default	50.0%	Min.unit	0.1%
	Setting range	0.0~150.0%			

This group of parameters are valid only on the distance control mode, when door-open run to the set door-open limit position, if the output torque bigger than the F307, then the door-width pulse will be reset as 100%, and into the torque holding state; if the output torque not exceeds the F307 after locked-rotor, then decrease the F307 slightly to make sure that the door-width pulse can be reset.

F308	Open door arrival torque holding	Default	50.0%	Min.unit	0.1%
	Setting range	0.0~150.0%			

This parameter is used to set the holding torque after the door-open limit.

F309	Door-open blocked torque	Default	80.0%	Min.unit	0.1%
	Setting range	0.0~150.0%			

Set the door-open blocked torque, the up limit of door-open torque is 110%of the blocked torque.

F310	Door-open startup torque	Default	0.0%	Min.unit	0.1%
	Setting range	0.0%~F309			

This parameter is used to set the start torque when door-open start to make sure the effect of door-machine start. The torque is the product of this function code and the motor rated torque.

F311	Door-open blocked judging time	Default	0ms	Min.unit	1ms
	Setting range	0~9999ms			

This is the filtering time when door-open blocked, no detection for door-open blocking when this parameter is set as 0.

6.5 F4- Door closing run curve

Correctly set the parameter in F4 group which related to speed control, precisely set slowdown signal switch and limit signal switch, open-door run speed curve can be detailed as fig6-5.

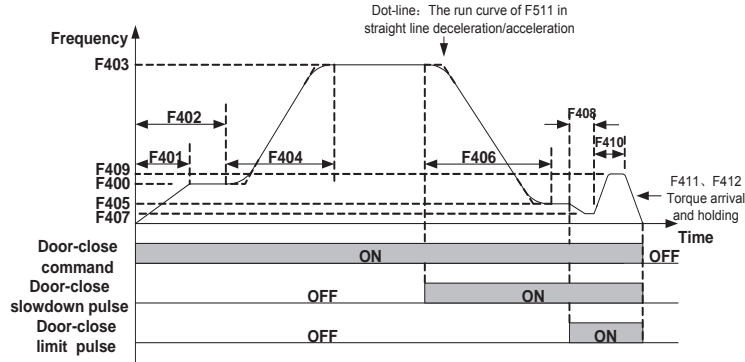

Speed control door closing process:

- 1) When the door closing command is valid, door machine accelerate to F401 speed then run at constant speed in the door closing low speed stage.
- 2) Time from door closing starting, when the time reaches low speed run time (F402), then door machine switch to high speed (F403), and speedup at F404 time, then constant run in the high speed stage.
- 3) When the door closing signal is valid, door machine set F405 as target speed, slowdown with F406 time, when the deceleration is over then run at constant speed in the door closing finish low speed stage.
- 4) When the door closing limit signal is valid, door machine continue to creeping at door open finish low speed, after locked-rotor, entering door closing torque holding state, holding torque as F408, a complete door closing process is over.
- 5) When the closing command is invalid, open torque holding is over.
- 6) Dotted line display: running curve When the door closing curve selection (F511) is straight line acceleration/slowdown.

Correctly set parameter in F4 group which related to distance control, set relevant pulses, the door opening speed curve can be detailed as fig 6-6.

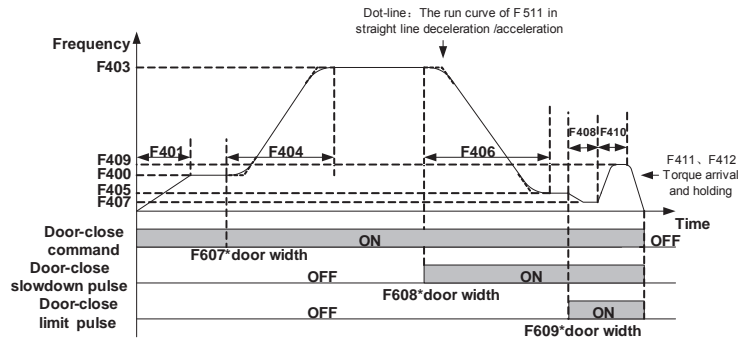

Distance control door closing process:

- 1) When the door closing command is valid, door machine accelerate to F400 creeping speed then run at constant speed in the door closing low speed stage.
- 2) When the door-closing distance reaches F607*door width, then door machine switch to high speed (F403), and speedup at F404 time, then constant run in the high speed stage.
- 3) When the door-opening distance reaches F608*door width, door machine set F405 as target speed, slowdown with F406 time, when the deceleration is over then run at constant speed in the door closing finish low speed stage.
- 4) When door opening distance pulse reaches F609, door machine continue to creeping at door closing finish low speed, after locked-rotor, entering door opening torque holding state, holding torque as F408, a complete door open process is over.
- 5) When the closing command is invalid, open torque holding is over.
- 6) Dotted line display: running curve when the door closing curve selection (F511) is straight line acceleration/slowdown.

F409	Skate withdraw speed setting	Default	2.0 hz	Min. unit	0.01 hz
	Setting range	0.00~F403			

This is the running speed when the door-machine skate withdraw during door-closing

F410	Skate withdraw run time	Default	500MS	Min. unit	1MS
	Setting range	0~9999MS			

The door-machine will run again, when the skate-withdraw time exceeds the F410.

F411	Door-closing limit torque switching point setting	Default	50.0%	Min. unit	0.1%
	Setting range	0.0-150.0%			

This function only valid on the distance control mode, when the door-close skate withdraw run finished, if the controller output torque exceeds the F411, door-width reset to 0% and enter the door-close limit torque holding state.

F412	Door-closing torque switching-point setting	Default	10.00Hz	Min. unit	0.01Hz
	Setting range	5.00~30.00Hz			

F414	Close door arrival torque holding	Default	1	Min. unit	1
	Setting range	0-1			

0: stop when door-closing blocked, close when the open command given after or within 10s; respond to the closing call when the run command off

1: re-open when door-closing blocked, no response to the outside door orders during re-opening.

A: light-curtain/touch plate signal valid during door-closing running

B: the output torque exceeds the block torque during door-closing running

When the fire emergency input function is valid, door closing high speed running.

F415	Door-close blocked judging time	Default	500ms	Min. unit	1ms
	Setting range	0~9999ms			

This is the filtering time when door-close blocked, no judgement for the door-close when set this parameter as 0.

F416	Fire emergency closing high speed setting	Default	10.00Hz	Min. unit	0.01Hz
	Setting range	5.00~F104			

This is the run speed of door-machine closing when the fire-emergency input function is valid.

F417	Door-close blocked hi-speed setting	Default	12.00Hz	Min. unit	0.01Hz
	Setting range	F418~F104			
F418	Door-close blocked low-speed setting	Default	2.00Hz	Min. unit	0.01Hz
	Setting range	0.00Hz~F104			
F419	High-speed blocked torque setting	Default	100.0%	Min. unit	0.1%
	Setting range	0.00~150.0%			
F420	Low-speed blocked torque setting	Default	100.0%	Min. unit	0.1%
	Setting range	0.00~150.0%			

These 4 parameters are used to judge the door-close blocked solutions:

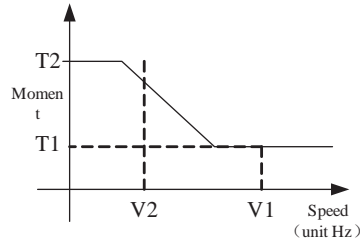

- 7) V1 stands for the F417, V2 stands for F418, T1 stands for the F419, T2 stands for F420, make sure $F417 \geq F418, F419 \leq F420$. When the frequency exceeds V1 on door-closing run, then the torque percentage of blocking judging is T1; when the frequency exceeds V2 on door-closing run, then the torque percentage of blocking judging is T2. When the run frequency is between V2 and V1, then the percentage is shown as the slant part as the diagram.

6.6 F5-Door auxiliary parameter

F500	Abnormal deceleration time	Default	0.3s	Min. unit	0.1s
	Setting range	0.1~5.0s			

When the door closing was blocked, slowdown from current closing speed to zero, the parameter should be set as small as possible in the condition of no over-current when slowdown.

F501	Door open time limit	Default	0s	Min. unit	1s
	Setting range	0~9999s			

The max. door opening time, users can set this parameter bases on the actual condition. The set value should not be smaller than the totality of all the door opening time (door opening run curve parameter group), otherwise parameter setting error (Er26) will occurs. Correctly set this parameter can realize the door machine abnormal protection. If the door opening limit lose effect, and running time exceeds the setting range will give rise to door opening error protection (Er28). Set as zero, this function is invalid.

F502	Door closing time limit	Default	0s	Min. unit	1s
	Setting range	0~9999s			

The max. door closing time, users can set this parameter bases on the actual condition. The set value should not be smaller than the totality of all the door closing time (door closing run curve parameter group), otherwise parameter setting error (Er26) will occurs. Correctly set this parameter can realize the door machine abnormal protection. If the door closing limit lose effect, and running time exceeds the setting range will give rise to door closing error protection (Er29). Set as zero, this function is invalid.

F503	low speed run time limit	Default	0s	Min. unit	1s
	Setting range	0~9999s			

The max. low speed run time when the low speed run signal is valid, users can set this parameter bases on the actual condition. The set value should not be smaller than the totality of all the door open/ closing time (door open/closing curve parameter group), otherwise parameter setting error (Er26) will occurs. Correctly set this parameter can realize the door machine low speed run abnormal protection. If the door open/ closing limit lose effect, and running time exceeds the setting range will give rise to low speed door open/closing error protection (Er30). Set as zero, this function is invalid.

F504	External door opening command delayed time	Default	0s	Min. unit	1s
	Setting range	0~9999s			

Within the door open arrival holding time, when the run command of door open terminal is invalid, the holding time should not be smaller than the function parameter, the controller stop. Before door open arrival, if the open command was cancelled, the controller will immediately stop, and the time-delay function will be invalid.

F505	External door closing command delayed time	Factory default	0s	Min. unit	1s
	Setting range	0~9999s			

Within the door closing arriving holding time, when the run command of door closing terminal is invalid, the holding time should not be smaller than the function parameter, the controller stop. Before door closing arrival, if the closing command was cancelled, the controller will immediately stop, and the time-delay function will be invalid. This function code used to set the torque holding time of door-open limit.

F506	Door-open curve	Default	1	Min. unit	1
	Setting range	0~1			

This parameter used to set the door-machine run curve when door-open run

0:straight line acceleration/deceleration;

1:S curve acceleration;

F511	Door-close curve select	Default	1	Min. unit	1
	Setting range	0~1			

This parameter used to set the door-machine run curve when door-close run

0:straight line acceleration/deceleration;

1:S curve acceleration;

F507	Open-door acceleration S curve initial time	Default	20.0%	Min. unit	0.1%
	Setting range	10.0%~50.0% (acceleration/deceleration time) (initial stage+ascend stage≤90%)			

F508	Open-door acceleration S curve hoist time	Default	60.0%	Min. unit	0.1%
	Setting range	10.0%~80.0% (acceleration/deceleration time) (initial stage+ascend stage≤90%)			
F509	Open-door deceleration S curve initial stage time	Default	20.0%	Min. unit	0.1%
	Setting range	10.0%~50.0% (acceleration/deceleration time) (initial stage+ascend stage≤90%)			
F510	Open-door deceleration S curve descend stage time	Default	60.0%	Min. unit	0.1%
	Setting range	10.0%~80.0% (acceleration/deceleration time) (initial stage+ascend stage≤90%)			
F512	Close door acceleration S curve initial stage time	Default	20.0%	Min. unit	0.1%
	Setting range	10.0%~50.0% (acceleration/deceleration time) (initial stage+ascend stage≤90%)			
F513	close door acceleration S curve ascend stage time	Default	60.0%	Min. unit	0.1%
	Setting range	10.0%~80.0% (acceleration/deceleration time) (initial stage+ascend stage≤90%)			
F514	close door deceleration S curve initial stage time	Default	20.0%	Min. unit	0.1%
	Setting range	10.0%~50.0% (acceleration/deceleration time) (initial stage+ascend stage≤90%)			
F515	close door deceleration S curve descend stage time	Default	60.0%	Min. unit	0.1%
	Setting range	10.0%~80.0% (acceleration/deceleration time) (initial stage+ascend stage≤90%)			

T1 is the F507 parameter, and the slope of output frequency within this period is gradually increasing (the percentage speed variation, same below), T2 is the time defined by the F508, the slope within this period is gradually change to low-speed frequency. The slope of output frequency is fixed within the time of T1 and T2.

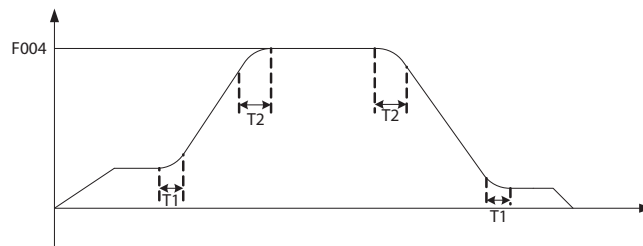

Figure 6-7 Speed-up/down Curve

F516	Speed bias setting	Default	50%	Min. unit	0%
	Setting range	0%~80%			
F517	speed bias judging time	Default	400ms	Min. unit	1ms
	Setting range	0~5000ms			

The speed bias detection is only valid on the close-loop vector control mode. Detect whether the bias is oversize according to the F516, Err 32 will occurs if the bias accumulate time exceeds F517.

No detection when the F516 set as 0.

F518	Door-close constant speed delay	Default	200ms	Min. unit	1ms
	Setting range	0~9999ms			

When the door-closing enter the high-speed state, close the door after the constant speed delay of F518.

6.7 F6-Distance control parameter

F600	Door width auto-tuning function selection	Default	0	Min. unit	1
	Setting range	0~1			

When this function parameter change from 0 to 1, pressing OPEN or CLOSE key to start door width auto-tuning, run with the logic of CLOSE-> OPEN-> CLOSE, when door opening arrival locked-rotor occurs, store door width, the door width auto-tuning is only valid in door machine manual adjusting mode , please refers to CHAPTER 7 for details.

F601	Door width auto-tuning speed	Factory default	4.00Hz	Min. unit	0.01Hz
	Setting range	0~F002 (Max. freq.)			

F602	Door- width pulse low bit	Default	0	Min. unit	1
	Setting range	0~9999			
F603	Door-width pulse high bit	Default	0	Min. unit	1
	Setting range	0~9999			

Door width measure method:door width=F603×10000+F602. Door width pulse number which obtained by auto-tuning can be modified by keyboard.

F604	Distance control open startup low speed run distance	Default	10.05	Min. unit	0.1%
	Setting range	0.0-30.0%			

In the process of distance control door-opening, record the real time walking pulses. The door machine shift from the door-opening start low speed (F300)to the high speed (F303)when the pulse is not smaller than the door width * F604.

F605	Distance control door-opening slowdown point setting	Default	70.00%	Min. unit	0..1%
	Setting range	60.00%-90.00%			

In the process of distance control door-opening, record the real time walking pulses. The door machine shift from the door-opening start high speed (F303) to the low speed (F305) when the pulse is not smaller than the door width * F605.

F606	Distance control door-opening limit point setting	Default	96.0%	Min. unit	0.1%
	Setting range	80.00%-99.00%			

In the process of distance control door-opening, record the real time walking pulses. Operates the door-opening arrival relative process when the pulse is not smaller than the door width * F606

F607	Distance control close startup low speed run distance	Default	10.0%	Min. unit	0.1%
	Setting range	0.0-30.0%			

In the process of distance control door-opening, record the real time walking pulses. The door machine shift from the door-closing start low speed (F300) to the high speed (F303) when the pulse is not bigger than the door width * (100%-F607)

F608	Distance control door-close slowdown point setting	Default	70.0%	Min. unit	0.1%
	Setting range	60.00%-99.0%			

In the process of distance control door-opening, record the real time walking pulses. The door machine shift from the door-closing start high speed (F303) to the low speed (F305) when the pulse is not bigger then the door width * (100%-F608)

F609	Distance control door-closing limit point setting	Default	96.0%	Min. unit	0.1%
	Setting range	80.0%-99.0%			

In the process of distance control door-opening, record the real time walking pulses. Operates the door-closing arrival relative process when the pulse is not bigger than the door width* (100%-F609)

F611	Low-bit of door-open limit switch	Default	0	Min. unit	1
	Setting range	0~9999			
F612	High-bit of door-open limit switch	Default	0	Min. unit	1
	Setting range	0~9999			
F613	Swotch position of the door-closing	Default	0	Min. unit	1
	Setting range	0~9999			

During normal run, when the door-open limit is valid, the door position is $F612 * 10000 + F611$; while the door-close limit is valid, the door position is F613.

F614	Door-width auto-tuning and initial run torque setting	Default	80.0%	Min. unit	0.1%
	Setting range	0.0~150.0%			

This parameter valid only on the distance control mode, used to set the door-width auto-tuning and torque judgment level of 1st power on.

F615	Pulse low-bit of the door-open deceleration point	Default	0	Min. unit	1
	Setting range	0~9999			
F616	Pulse high-bit of the door-open deceleration point	Default	0	Min. unit	1
	Setting range	0~9999			
F617	Pulse low-bit of the door-closing deceleration point	Default	0	Min. unit	1
	Setting range	0~9999			
F618	Pulse high-bit of the door-closing deceleration point	Default	0	Min. unit	1
	Setting range	0~9999			

Door-open deceleration point is $F616*10000+F615$; while the door-close deceleration point is $F618*10000+F617$;

F619	Door-width setting when door-open limit	Default	0.0	Min. unit	0.1
	Setting range	0.0~99.9%			

This parameter is valid on the distance control mode.

When the door-width position exceeds F619 to output door-open limit signal, then the door-width will not be reset as 100% even if the output torque exceeds the door-open limit switch point torque, only when it exceeds F606, and also the output torque exceeds door-open limit switch point torque, the door-width will reset as 100%.

When the F619 is 0, judge whether to output door-open limit signal based on the F606.

F620	Door-width setting when door-closing limit	Default	0.0	Min. unit	0.1
	Setting range	0.0~99.9%			

This parameter is valid on the distance control mode. ;

When the door-width position exceeds F620 to output door-close limit signal and skate withdraw. Then the door-width will not be reset as 0% even if the output torque exceeds the door-close limit switch point torque. The door-width will be reset as 0% only when the door position exceeds F609 and also the output torque exceeds the door-close limit torque too.

When the F620 is 0, judge whether to output door-open limit signal based on the F609.

6.8 F7-Demonstrating function parameter

F700	Demonstrate door opening arrival holding time	Factory default	2.0s	Min. unit	0.1s
	Setting range	0.5~999.9s			

Demonstrate door opening arrival holding time means in the demonstrating mode, the time gap between opening arrival stop and opposite door closing, set it according to actual condition.

F701	Demonstrate door closing arrival holding time	Factory default	2.0s	Min. unit	0.1s
	Setting range	0.5~999.9s			

Demonstrate door closing arrival holding time means in the demonstrating mode, the time gap between closing arrival stop and forward direction door opening, set it according to actual condition.

F702	Demonstrate door operation times record	Factory default	0	Min. unit	1
	Setting range	0~9999			

Record parameter for demonstrate run times, auto saved when power removal, the value of this parameter will be added after re-powered. Add 1 each times after door opening, and closing. The demonstrating mode is an auto cycle run process, pressing OPEN or CLOSE key to start demonstration run, after starting, the machine close the door with low speed, and operate the door-opening run after closing limit, timing from opening arrival, operate auto door-closing run when the time reaches F700's setting value. When the closing time reaches F701's setting value, the machine open the door again, vice versa. Until pressing the STOP/RESET key to stop the machine. The demonstration run can be distance control or speed control. The demonstration mode can be applied to demonstrating and aging test.

F703	Demonstrate door operation times setting	Default	0	Min. unit	1
	Setting range	0~9999			

It used for setting demonstrating operation times, when the actual demonstrating operation door times are more than this function parameter, demonstrating operation automatically over.

6.9 F8-Auxiliary parameter

F800	Software version	Default	1.00	Min. unit	0.01
	Setting range	0.00~99.99			

Display the current software version of controller, for factory maintenance.

F801	Module temperutute	Default	0°C	Min. unit	1°C
	Setting range	0~100°C			

Update the bottom module temperature of controller at anytime.

F802	The number of automatic error reset	Default	0	Min. unit	1
	Setting range	0~100			

When the error occurs during running, controller stops and reset automatically to continue the running. No auto reset function (only manual reset) when set error reset times as 0. If no error during 1 hour or manual resetting occurs, the machine will reset the finished reset times as zero.

Remark: errors that can not be reset automatically:Er19- motor tuning error Er28-parameter setting error indicator, Er 27- door width auto tuning error.

F803	Brake utilization ratio	Default	100%	Min. unit	1%
	Setting range	0~100%			

It is valid to inverter of inside brake unit, can adjust the braking effect of brake unit.

F804	accumulative working time	Default	0	Min. unit	1
	Setting range	0~9999			

Controller accumulative power applied working time (hour). The max. Value is 9999 hours, re-accumulate when over 9999 hours.

F806	Accumulative running time	Default	0	Min. unit	1
	Setting range	0~9999			

Controller accumulates power applied working time (hour). The max. value is 9999 hours, re-accumulate when over 9999 hours.

F810	Auxiliary function select	Default	12	Min. unit	1
	Setting range	0~9999			

BIT	Function	Default
BIT0	1:triggering door command 0:no-triggering command	0
BIT1	1:no reset pulse when the initial run torque arrive 0:pulse reset when torque arrive	0
BIT2	1:learn the limit switch position when door-width auto-learning, and reset the pulse signal when the limit switch valid 0:No;	1
BIT3	Flux vector.distance control mode: 1:Judge the door-width aito-learning, initial run with the toruqe and judge the blocking.; 0: judge as auto-learning finish, initial run limit or door-close blocked if no pulse within 2 s.;	1
BIT4	1:door-close proor 0:door-open prior	0

BIT5	Terminal control mode: 1:the controller still wirking when pressing STOP 0: the controller pause and display STP when pressing STOP, back to normal when pressing again.	0
BIT6	Blocking mode 1:judge the blocking torque based on F413.; 0:seperately detect for high/low speed;	0
BIT7	DEMO run: 1:Enter demo when power on automatically; 0:manually start demo when power on;	0
BIT8	Current removal: 0:current removal when command removal; 1:stop run when command removal;	0

F812	Drive function select	Default	0	Min. unit	1
	Setting range	0~9999			

BIT0:0:7 stage modulation(reduce noise);1:Auto change of 7 stage/5 stage during running;

F814	Overload factor	Default	1.00	Min. unit	0.01
	Setting range	0~10.00			

It is used for the motor overload protection

F816	Door-machine amount	Default	1	Min. unit	1
	Setting range	1~2			

When select the communication protection, please set the front door F816 as 1, back door F818 as 2.

6.10 F9-I/O function parameter

F900	Filtering time	Default	20ms	Min. unit	1ms
	Setting range	0~100ms			

Setting the sensitivity of input terminal, if the digital input terminal is likely to be interfered, please set this parameter bigger to avoid interfere,but the sensitivity will be reduced.

F901	digital quantity input terminal	Default	0	Min. unit	1
F908	Setting range	0~116(no repeat selection)			

0: Non;

1: Door opening command, door opening command signal;

2: Door closing command, door closing signal;

3: External RESET input, external error reset terminal signal;

4: Door opening forbidden terminal input, controller give no response to external door-opening command;

5: Torque holding forbid terminal input, during the door opening/closing arrival torque holding, holding the torque as zero when the signal is valid.;

6: Low speed door enable input, the system run with low speed freq. (F006) when the signal is valid.;

7: Fire emergency input, close the door with fire emergency high speed freq. (F 419) when the signal is valid.;

8~109:reserved

10/110:Light beam curtain signal N.O/N.C. input, during door closing process, if the signal terminal is valid, the door-closing blocked protection will be operated. No response to door-closing will be given during re-opening process, if the door closing limit position was reached, the protect signal will ne invalid.

11/111:Touch plate signal N.O/N.C. input, during door closing process, if the signal terminal is valid, the door-closing blocked protection will be operated. No response to door-closing will be given during re-opening process, if the door closing limit position was reached, the protect signal will ne invalid.

12/112: Door opening limit signal N.O/N.C. input.

13/113:Door opening limit signal N.O/N.C. input.

14/114 Door opening slowdown signal N.O/N.C. input. In the speed control door opening process, when the signal is valid, switch to low speed running.

15/115:Door closing slowdown signal N.O/N.C. input. In the speed control door closing process, when the signal is valid, switch to low speed running.

16/116:Door lock signal N.O/N.C input, receiving the relevant information of door lock.

F909	relay output selection TA1/TB1/TC1	Default	4	Min. unit	1
	setting range	0~11			
F910	Relay output selection TA2/TB2/TC2	Default	0	Min. unit	1
	Setting range	0~11			
F911	relay output selection TA3/TB3/TC3	Default	3	Min. unit	1
	setting range	0~11			

0:non;

1: Door opening arrival signal output 0, in the opening process, when the controller receive door opening limit signal or the pulses reaches the set value, then output door opening arrival signal 0.

2:Door closing arrival signal output 0, in the closing process, when the controller receive door closing limit signal or the pulses reaches the set value, then output door closing arrival signal 0.

3:Door opening arrival signal output 1, in the opening process, when the controller receive door opening limit signal or the pulses reaches the set value, and locked-rotor torque reaches

F316 set value, then output door opening arrival signal 1.

4: Door closing arrival signal output 1, in the closing process, when the controller receive door closing limit signal or the pulses reaches the set value, and the ratio of locked-rotor torque and rated torque reaches F417 set value, then output door closing arrival signal 1.

5:error signal output 1 (Er26 is just reminding information, not error) .

6:reserved.

7:Door opening arrival signal output 2, in the opening process, when the controller receive door opening limit signal or the pulses reaches the set value, door lock signal is invalid and the ratio of locked-rotor torque and rated torque reaches F316 set value, then output door opening arrival signal 2.

8:Door closing arrival signal output 2, in the closing process, when the controller receive door closing limit signal or the pulses reaches the set value, and the ratio of locked-rotor torque and rated torque reaches F417 set value, then output door closing arrival signal 2.

9:Door lock signal output, the synchronously I/O door lock signal.

10:Re-opening signal output, output re-opening state signal.

11:Blocked signal output, in the closing process, when blocked then output signal.

6.11 FA-Display & Error parameter

FA00	LED run parameter display selection	Default	319	Min. unit	1
	Setting range	1~511			

This group controls 9 state parameter display, every parameter was controlled by a binary code, "1" means display the parameter, "2" means do not display the parameter. In the control system run state, change the parameter display state by the SHIFT key.

FA01	LED off parameter display selection	Default	39	Min. unit	1
	Setting range	1~63			

This group controls 6 state parameter display, every parameter was controlled by a binary code, "1" means display the parameter, "2" means do not display the parameter. In the control system run state, change the parameter display state by the SHIFT key.

FA02	1st error category	Default	0	Min. unit	1
	Setting range	0~30			
FA03	1st error remark	Default	0	Min. unit	1
	Setting range	0~9			
FA04	2nd error category	Default	0	Min. unit	1
	Setting range	0~30			
FA05	2nd error remark	Default	0	Min. unit	1
	Setting range	0~9			
FA06	3rd error category	Default	0	Min. unit	1
	Setting range	0~30			
FA07	3rd error remark	Default	0	Min. unit	1
	Setting range	0~9			
FA08	4th error category	Default	0	Min. unit	1
	Setting range	0~30			
FA09	4th error remark	Default	0	Min. unit	1
	Setting range	0~9			
FA10	5th error category	Default	0	Min. unit	1
	Setting range	0~30			
FA11	5th error remark	Default	0	Min. unit	1
	Setting range	0~9			
FA12	Bus voltage in the latest error	Default	0V	Min. unit	0.1V
	Setting range	0~999.9V			
FA13	Output current in the latest error	Default	0.00A	Min. unit	0.01A
	Setting range	0~99.99A			
FA14	Run freq. in the latest error	Default	0.00Hz	Min. unit	0.01Hz
	Setting range	0~99.00Hz			

FA15	Output torque in the latest error	Default	0.0%	Min. unit	0.1%
	Setting range	0.0~180.0% (the percentage between output torque and rated torque)			
FA16	Input terminal state in the latest error	Default	0	Min. unit	1
	Setting range	0~1023			
FA17	Output terminal state in the latest error	Default	0	Min. unit	1
	Setting range	0~15			

This group of parameter record the controller last 5 errors and the latest error details, please refer to chapter 8 for details.

Remark: Er26 is just the reminding information of parameter setting error, do not saved in error record.

FA18	Terminal state query	Default	*	Min. unit	*
	Setting range	*			

This parameter is corresponding to the input/ output display of terminal side. When the input/ output function is valid, the corresponding LED segment is lighting. From left to right, there is LED1, LED2, LED3, LED4.

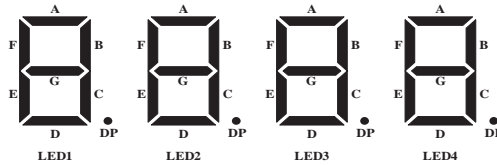

LED segment meaning as the following:

LED1 segments	"light" meaning	LED2~LED3 segments	"light" meaning	LED4 segment	"light" meaning
A	D11 input valid	Reserved	Reserved	A	A1.C1 connected
B	D12 input valid			B	A2.C2 connected
C	D13 input valid			C	A3.C3 connected
D	D14 input valid			D	Reserved
E	D15 input valid			E	
F	D16 input valid			F	
G	D17 input valid			G	
DP	D18 input valid			DP	

FA19	Fuction input state query		Default	*	Min. unit	*
	Setting range	*				

This parameter is corresponding to the input display of function part. When the input function is valid, the corresponding LED segment is lighting. From left to right, there is LED1, LED2, LED3, LED4.

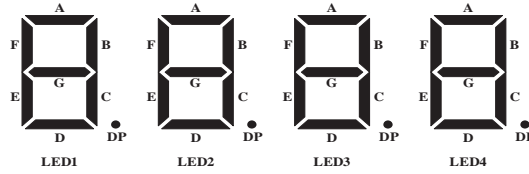

LED segments meaning as the following:

LED1 segments	"light" meaning	LED2 segments	"light" meaning	LED3~LED4 segments	"light" meaning
A	Door opening command is valid	A	Reserved	Reserved	Reserved
B	Door closing command is valid	B	Light beam curtain signal is valid		
C	External reset is valid	C	Touch plate signal is valid		
D	Door opening forbidden is valid	D	Door opening limit signal is valid		
E	Torque holding forbidden input is valid	E	Door closing limit signal is valid		
F	Low speed opening input is valid	F	Door opening slowdown signal is valid		
G	Fire emergency input is valid	G	Door closing slowdown signal is valid		
DP	Reserved	DP	Door lock signal is valid		

FA20	Function output state query		Default	*	Min. unit	*
	Setting range	*				

This parameter is corresponding to the output display of function part. When the output function is valid, the corresponding LED segment is lighting. From left to right, there is LED1, LED2, LED3, LED4.

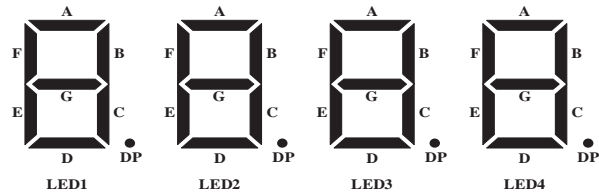

LED segments meaning :

LED1 segments	"light" meaning	LED2 segment	"light" meaning	LED3~LED4 segment	"light" meaning
A	Door opening arrival signal output 0	A	Door lock signal output	Reserved	Reserved
B	Door closing arrival signal output 0	B	Door re-opening signal output		
C	Door opening arrival signal output 1	C	blocked signal output		
D	Door closing arrival signal output 1	D	Reserved		
E	Error signal output 1	E			
F	Reserved	F			
G	door opening arrival signal output 2	G			
DP	Door closing arrival signal output 2	DP			

FA21	Display switch control		Default	0	Min. unit	1
	Setting range	0~9999				

This parameter is applied to set the actual display of FA 22 and FA23, adopts for spot error identification and adjusting.:

Set value	FA22 display	FA23 display
1	Average speed within 1s (Hz)	speed fluctuate average within 1s (Hz)
2	max. speed within 1s (Hz)	Min. speed within 1s (Hz)
3	Slip freq. (Hz)	Actual feedback freq. (Hz)
4	Excitation current component (A)	Torque current compenent (A)
Others	Receicing encoder pulses within 1s (high bit)	Receiving encoder pulse within 1s (low bit)

FA22	Display 1		Default	0	Min. unit	1
	Setting range	0~9999				
FA23	Display 2		Default	0	Min. unit	1
	Setting range	0~9999				

FA24	analog voltage display	Default	0.00V	Min. unit	0.01V
	Setting range	0.00~10.10V			

Display the current part analog sampling voltage

6.12 FP-user parameter

FP00	User password	Default	0	Min. unit	1
	setting range	0~9999			

Set it as any number except zero so that the password protection function is valid.

00000: eliminate the former user's password value and make password protect function invalid.

When user password is set and become effective,

Please fix your password. If mis-setting or forget, please contact with factory.

FP01	Parameter update	Default	0	Min. unit	1
	Setting range	0~2			

0:non;

1:restore factory setting;

2:clean error record and time.;



Application and adjustment

Chapter 7 Application and adjustment

This chapter introduces in details the basic procedures of system design and function parameter setting method when NICE900 controller is used to form door machine application system. The following is the respective application of speed control and distance control.

7.1 Door machine controller adjustment

7.1.1 Adjustment flow

To make door machine controller adjustment convenient, this chapter lists common setting order of the parameters of the controller. When external circuit and mechanical installation are ready, basic adjustment of door machine controller can be completed. Adjustment flow refers to Fig7-1:

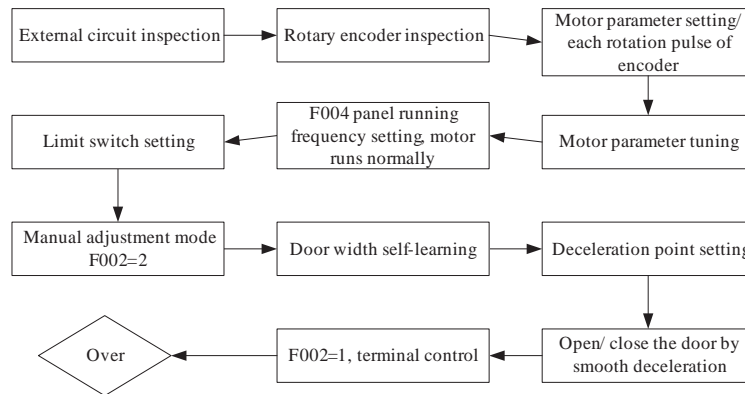

Fig 7-1 Basic adjustment flow of Door machine

7.1.2 Wiring inspection

Before power-on external wiring should be inspected to ensure the security of parts and people.

- 1) Wire correctly according to the drawing provided by manufacturer;
- 2) Every switch works normally, action is reliable;
- 3) Inspect inter phase resistance of the main circuit, check if there's short to ground;
- 4) Make sure mechanical installation is OK, it will not bring equipment damage or personal injury;

7.1.3 Encoder inspection

Pulse signal given out by encoder is the guarantee for the system to realize precise control, it must be checked before adjustment.

- 1) The encoder should be mounted steady, and grounded well.

- 2) Signal wire of the encoder and heavy current circuit should be placed in different slots to avoid interference.
- 3) It's better to introduce the wire of encoder to controller directly. If the wire is not long enough, the added part should be shielded wire, and it's better to connect it with original wire by welding with soldering iron.
- 4) Sheilded layer of encoder should be grounded at the side of the controller.

7.1.4 Grounding inspection

Check if the resistance between the following terminals and grounding terminal PE is boundless, inspect at once if it's not big enough.

- 1) L.N and PE;
- 2) U.V.W and PE;
- 3) Encoder 24V.PGA.PGB.PGZ.COM and PE;

7.1.5 Application of synchronous motor

Before the first use of permanent-magnet motor, magnetic pole position must be identified, otherwise, it cannot be normally used. When motor wiring, encoder or encoder wiring is changed, encoder position must be identified again. As a result, it must be ensured that the wiring of magnetic position identification and that of motor normal running are completely the same. In the process of identification motor may rotate, so please check it's safe before tuning. Tuning flow refers to Fig 7-2:

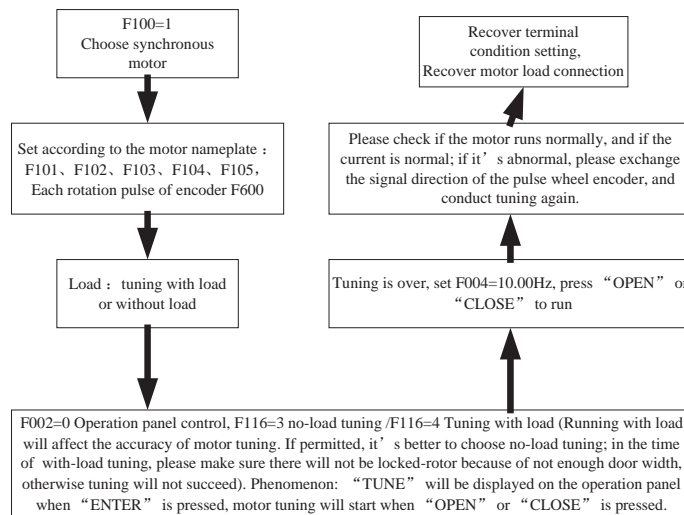

Fig 7- Tuning flow of sync motor

Before identification F1 Group motor nameplate parameters should be input correctly, including rated power, rated voltage, rated frequency, rated speed, rated current, and pulse of the encoder (F600) should be set correctly (F600). And then set F116 to 3 or 4, press "ENTER", inverter will display "TUNE". The controller start to identify the parameters when "OPEN" or "CLOSE" is pressed. During the process of identification the inverter will display "TUNE" all the time, the identification finishes when "TUNE" disappears.

The result of identification is the mount position angle of the encoder, it will be put in F114, and it can be checked and changed, but after position identification it cannot be changed again, or the controller may fail to work normally.

If Er19 appears in the process of encoder position identification, please check if the wiring is right.the inverter is under with-sensor vector control mode (make sure control mode F000 is set to 1).

7.1.6 Door width self-learning

In the process of door width self-learning, action direction of the door can changed automatically, so it should be done in the condition that personal safety is ensured.

It must be made sure that there's no obstacle in the way of door action before door width evaluation. If there's obstacle, it should be judged as arrival, in this condition door width cannot be evaluated correctly. Time order of door width evaluation refers to Fig7-3:

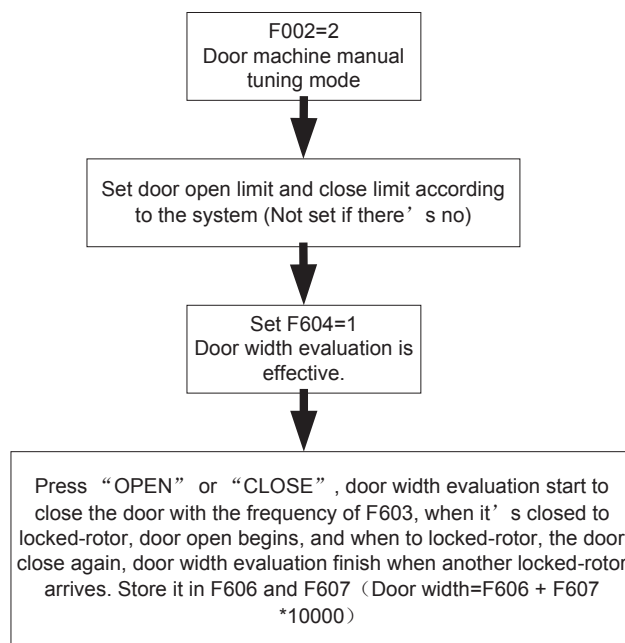

7.1.6 est run

After encoder position identification, please do test run before the elevator is loaded. It is suggested that test run applies inverter panel control mode.

The following two points should be paid attention to in test run:

- 1) Whether the motor running direction is in accordance with the actual situation (door open, door close). If not, the wiring of controller output side to motor should be adjusted, and encoder position identification should be done once again.
- 2) Whether forward and reverse running of the motor are stable, without noise. As there's no load, the current in controller is very small.

When the above two points are made sure, door machine controller has recorded accurate position of the motor and the encoder in F114 (Users can take them down for later use), at this time normal control of the motor can be conducted. As asynchronous motor and synchronous motor are different, users can reduce the gain of F2 Group speed loop PI Properly.

7.2 Typical application

7.2.1 Speed control mode

The speed control slowdown through the deceleration point. The limit signal will realize the arrival judgment and treatment. System wiring of speed control refers to Fig 7-1:

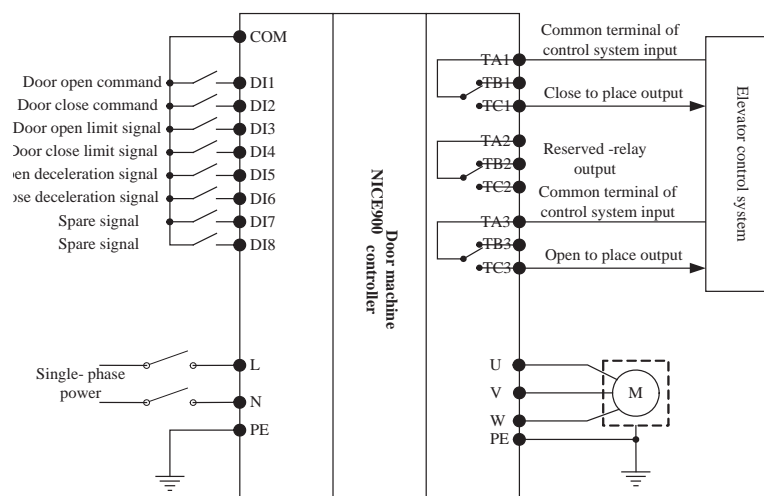

Fig 7-3 Wiring of typical application of speed control system

Effective curve of door open command in the process door close refers to Fig 7-2:

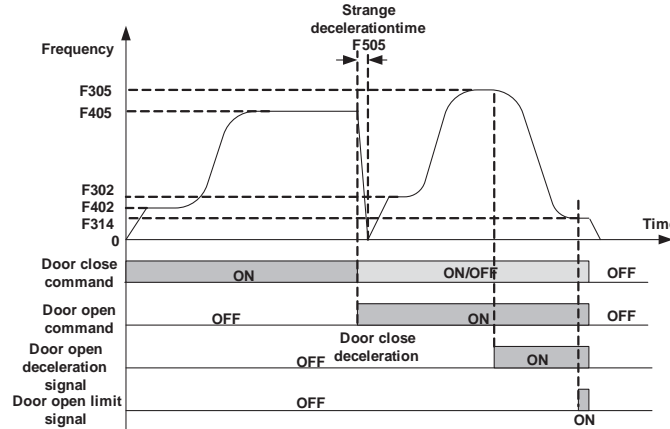

Fig 7-2 Effective curve of door open command in the process door close

In the process of door close, the elevator decelerates to stall when it is blocked, deceleration time is F505 (strange deceleration time). When reopening the door, the elevator starts up and runs at a low speed during low-speed running time (F303) and then runs at a high speed. After door open deceleration signal is effective, it starts to run at a low speed until door open to place, outputting door open to place signal.

7.2.2 Distance control mode

1) Wiring of Pulse + limit switch mode

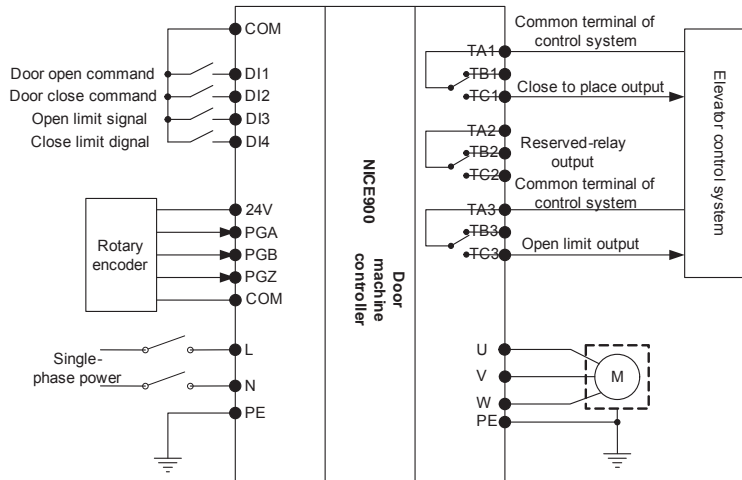

Fig 7-3 Distance control mode (Pulse+limit switch) wiring

2) Full pulse mode

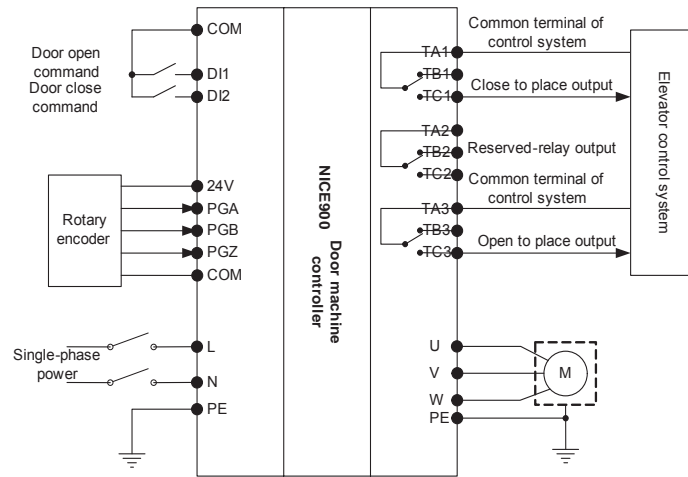

Fig 7-4 istance control mode(Full pulse) wiring

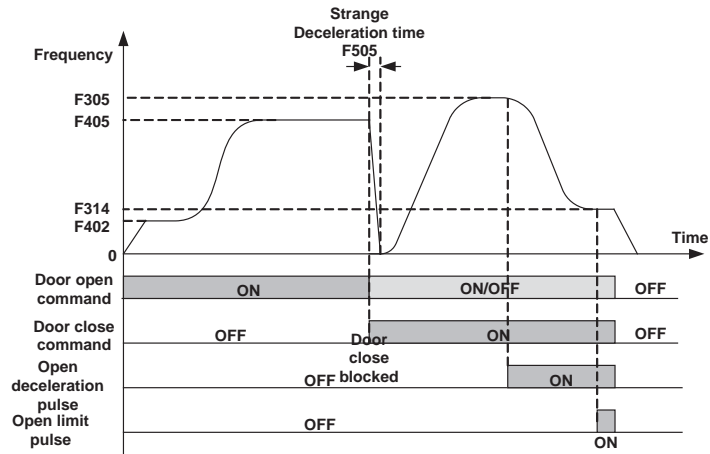

Fig 7-5



Fault Diagnosis and Countermeasures

Chapter 8 Fault Diagnosis and Countermeasures

Door machine controller has almost 30 pieces of alarm information and protection functions. The controller monitors all kinds of input signals, running conditions, external feedback and so on. As soon as there's abnormality appears, corresponding protection function will act and display error code at the same time.

If door machine controller displays fault alarm information, it can be handled according to different fault type. At this time, users can analyse the fault, identify the cause and find remedies taking the content of this chapter as a reference.

Fault display	Description	Possible causes	Remedy
Er02	Accelerated over-current	1.Main circuit output is grounded or short wired; 2.If the motor has done parameter tuning; 3.Load is too heavy;	1.Obviate exterior problems such as connection; 2.Tune motor parameters; 3,Lighten suddenly added load;
Er03	Deceleration over-current	1.Main circuit output is grounded or short wired; 2.If the motor has done parameter tuning; 3.Load is too heavy; 4. Deceleration curve is too steep;	1.Obviate exterior problems such as connection; 2.Tune motor parameters; 3,Lighten suddenly added load; 4.Adjust curve parameters;
Er04	Constant speed over-current	1.Main circuit output is grounded or short wired; 2.If the motor has done parameter tuning; 3.Load is too heavy; 4.Rotary encoder interference is too strong;	1.Obviate exterior problems such as connection; 2.Tune motor parameters; 3,Lighten suddenly added load; 4.Select proper rotary encoder, and adopt shielded cable;
Er05	Acceleration over-voltage	1.Input voltage is too high; 2 Brake resistance is too large, 3. Acceleration curve is too steep;	1.Adjust input voltage; 2. Select proper brake resistance; 3.Adjust curve parameter;
Er06	Deceleration Over-voltage	1.Input voltage is too high; 2.Brake resistance is too large; 3.Deceleration curve is too steep;	1.Adjust input voltage; 2.Select proper brake resistance; 3.Adjust curve parameter;
Er07	Constant speed over-voltage	1.Input voltage is too high; 2.Brake resistance is too large, or brake unit is abnormal;	1.Adjust input voltage; 2.Select proper brake resistance;
Er10	System overload	1. no blocking in the elevator door guild rail. 2.Load is too heavy;	1 Check the track to the elevator door 2 reduce the load;
Er13	Output phase-failure	1.The connections of main circuit output become loose; 2.Motor is broken;	1. Inspect connection; 2.Obviate motor fault;

Fault display	Description	Possible causes	Remedy
Er14	Module over-heated	1.Environmental temperature is too high; 2.The fan is broken; 3.The wind channel is blocked;	1.Reduce the environmental temperature; 2.Clear the wind channel; 3.Change the fan;
Er16	EEPROM Fault	EEPROM read-write is abnormal	Please contact with agent or factory;
Er18	Current inspection fault	Drive control panel is abnormal;	Please contact with agent or factory;
Er19	Motor tuning overtime	1.Motor parameter setting is incorrect; 2.Parameter tuning is overtime; 3.Rotary encoder of synchronous motor is abnormal;	1.Input the right motor parameter; 2.Detect motor lead wire; 3.Detect the wiring of rotary encoder, make surpulse of each rotation is set right;
Er20	Rotary encoder fault	1. If the model of rotary encoder matches; 2. Wiring of rotary encoder is not right;	1. Choose ABZ-phase rotary encoder of open collector type.; 2. Obviate wiring problem;
Er21	Initial position detection fault		
Er25	Over-speed fault	1.The speed of fast running during door open and close is bigger than 20% of the setting speed for 50ms.	1.Detect the wiring of encoder.
Er26	Parameter setting warning	1. Door open time (F500) is less than the total door open time; 2.Door close time (F501) is less than total door close time; 3.Command source (F002) is not in manual adjustment mode during door width self-learning, or door open and close mode selection (F001) is not in distance control mode; 4.when driving sync motor control mode (F000) choose magnetic flux vector control mode;	1.Set door open time limit bigger to ensure F500 is bigger than the sum of all the door open time parameters; 2.Set door open time bigger to ensure F500 is bigger than the sum of all the door open time parameters; 3.Command source (F002) is in manual adjustment mode or door open and close (F001) choose distance control mode at the time of door width self-learning; 4.When controlling synchronous motor (F100), control mode should be (F000) vector control;
Er27	Door width self-learning fault	1.Door width got in self-learning should be less than 50; 2.Before self-learning, the running should be in distance control mode;	1.Inspect the wiring of the encoder and relative parameters; 2.Inspect the mechanical system of door machine; 3.Conduct door width pulse self-learning before distance control running;

Fault display	Description	Possible causes	Remedy
Er28	Door open overtime	1.Motor running direction is opposite with that set in door open; 2.Signal fault or wrong setting door open limit; 3.Pulse encoder is disconnected;	1.Exchange phases of motor wiring or set F004=1; 2.Inspect door open limit signal; 3.Inspect the wiring of encoder;
Er29	Door close overtime	1.Motor running direction is opposite with that set in door open; 2.Signal fault or wrong setting door close limit; 3.Pulse encoder is disconnected;	1.Exchange phases of motor wiring or set F004=1; 2.Inspect door close limit signal; 3.Inspect the wiring of encoder;
Er30	Low-speed door open and close overtime	1.Signal fault or wrong setting door open limit; 2.Pulse encoder is disconnected;	1.Inspect door close limit signal; 2.Inspect the wiring of encoder;



ISMD1-5B0180A-I120XP PMSM specification

Chapter 9 ISMD1-5B0180A-I120XP PMSM specification

9.1 Motor parameter and size

9.1.1 Motor parameter

ISMD1-5B0180A-I120X PMSM			
Rated current:	0.49A	Rated torque :	2.7Nm
Rated voltage :	100V	Rated frequency :	24.00Hz
Rated rotary:	180r/min	Rated power:	50W
DC line resistance (20°C):	72±3.6 Ω	Linar inductance (20°C):	240±20% mH
Linar counter emf constant:	9.55±1 V/rad/s	Pole:	8
Working system:	S4	Ambient:	0°C~40°C
Shield level:	B	IP level:	IP44

9.1.2 specification and size

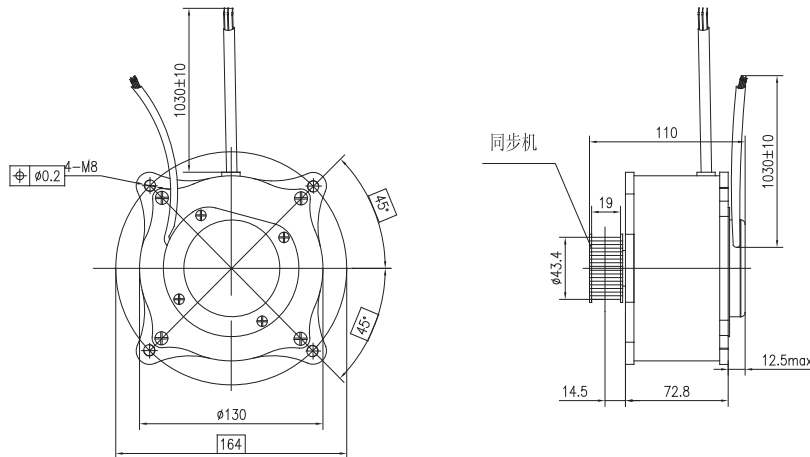

9.1.3 Power line of the motor

blue	Yellow	Brown
U	V	W

9.2 encoder parameter

ISMD1-5B0180A-I120X PMSM default with the encoder when manufactured, the details and wiring of the encoder are as the following:

Encoder	
Line:	1000
Input voltage:	100mA, range: DC 24V±10%
Responding frequency:	0~100kHz
Terminal type:	72Ω±3.6 Ω
Lead parameter:	9.55±1 V/rad/s
Working temperature:	0℃~70℃
Storage heat:	-40℃~80℃
Humidity:	90%

Encoder wiring:

Red	Black	Green	Orange	White
VCC	GND	A	B	Z

The output pulse of the encoder:

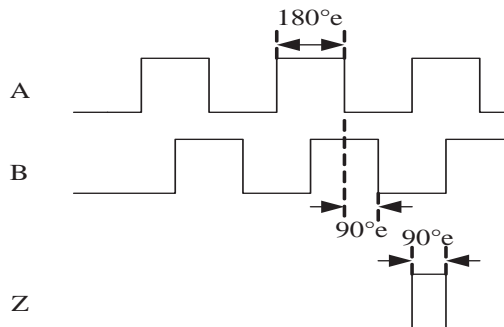

9.3 Motor torque calculation and motor selection instruction.

According to the torque balance formula:

$$T = F \times R$$

T is the torque, unit is NM

F is the force than needed to open/close the elevator door, unit is N

R is the diameter of the synchronous wheel, unit is M

Take ISMD1-5B0180A-I20X as instance, the rated load capacity for the motor is:

$$F = T / R$$

$$= 2.7 / 0.02$$

$$= 135 \text{ N}$$

Motor configuration basis:

- 1) Calculate the force that needed to open/close the door according to the actual load, take the max. Value
- 2) Measure the diameter of the synchronous wheel
- 3) Calculate the motor torque according the formula.

