

Preface

Thank you for purchasing the NICE900 series door machine controller.



This manual describes how to properly use the NICE900 series controller, covering installation, operation, maintenance and inspection of the equipment. Read and understand the instructions and safety precautions in the manual before the use.

Notes

- The drawings in the manual are sometimes shown without cover or protective guard. Remember to install the cover or protective guard as specified first, and then perform operations in accordance with the instructions.
- The drawings in the manual are shown for description only and may not match the product that you have purchased.
- The instructions are subject to change due to product upgrade, specification modification, as well as the efforts to increase the accuracy and convenience of the manual the manual.
- Contact the regional agent or customer service center of Inovance if the manual delivered is lost or damaged.
- Contact the customer service center of Inovance if you have problems during the use.
- Service Hotline: 400-777-1260.

Chapter 1 Safety Information and Precautions

In this manual, the notices are graded based on the degree of danger:

-  indicates that severe personal injury or even death may result due to improper operation.
-  indicates that personal injury or equipment damage may result due to improper operation.

Please read this chapter carefully so that you have a thorough understanding. Installation, commissioning or maintenance of the controller must be performed in conjunction with this chapter. Inovance will assume no liability or responsibility for any injury or loss caused by improper operation.

1.1 Safety Information

1.1.1 Before Installation



- Do not install the equipment if you find the controller damaged upon unpacking.
- Do not install the equipment if the packing list does not conform to the product you received.

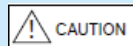

- Handle the equipment with care during transportation. Otherwise, the equipment may be damaged.
- Do not touch the components with your hands. Otherwise, static electricity damage may result.

1.1.2 During Installation



- Mount the controller on incombustible surface such as metal. Keep it far away from flammable materials. Otherwise, a fire may result.
- Do not loosen the fixed screws of the components, especially the screws with red marks.

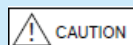

- Do not drop wire end or screw into the controller. Otherwise, the controller may be damaged.
- Install the controller in places free of vibration and direct sunlight.

1.1.3 Wiring



- Wiring must be performed only by authorized personnel under instructions described in this manual. Otherwise, unexpected accident may result.
- The power supply and the controller must be separated by a circuit breaker. Otherwise, a fire may result.
- Ground the controller properly by standard. Otherwise, electric shock may result.



- Do not connect power supply to the U, V, and W output terminals of the controller. Wrong wiring damages the controller.
- Ensure that wiring meets the EMC requirements and local safety standard. Use wire sizes recommended in the manual. Otherwise, accidents may result.
- Use the shielded wire for the encoder and ensure that one end of the shielding layer is grounded securely.
- Use shielded twisted pair (STP) cable with twist pitch of 20mm to 30 mm as for communication, and ground the shielding layer.

1.1.4 Before Power-On



- Check that the following requirements are met:
 - The voltage class of the power supply is consistent with the rated voltage class of the controller.
 - The input terminals (L1, L2) and output terminals (UVW) are correctly connected.
 - No short circuit exists in the peripheral circuit.
 - The wiring is secured.If any of the requirements is not met, the controller may be damaged.
- In the applications where the permanent magnet synchronous motor (PMSM) is controlled, ensure that motor tuning is performed before running for the first time. Otherwise, motor runaway may result.
- Do not perform the voltage resistance test on any part of the controller because such test has

been done in the factory. Otherwise, accidents may result.



- Cover the controller properly before power-on. Otherwise, electric shock may result.
- All peripheral parts must be connected correctly under the instruction described in this manual. Otherwise, accidents may result.

1.1.5 After Power-On



- Do not open the cover plate of the controller after power-on. Otherwise, electric shock may result.
- Do not touch any input or output terminal of the controller with hands. Otherwise, electric shock may result.



- If motor tuning is required, avoid personal injury during motor rotation.
- Do not change the factory parameters. Otherwise, the equipment may be damaged.

1.1.6 During Running

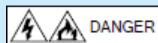

- Do not touch the fan or the discharging resistor to check the temperature. Otherwise, you may get burnt.
- Signal detection must be performed only by qualified personnel during operation. Otherwise, personal injury or equipment damage may result.

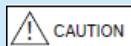

- Avoid objects falling into the controller when it runs. Otherwise, the controller may be damaged.
- Do not start/stop the controller by turning on or off the contactor. Otherwise, the controller may be damaged.

1.1.7 During Maintenance



- Do not repair or maintain the controller at power-on. Otherwise, electric shock may result.
- Repair or maintenance of the controller must be performed only by authorized personnel. Otherwise, personal injury or equipment damage may result.
- Reset the parameters when the controller is replaced. All the pluggable parts must be inserted or plugged after power-off.

1.2 Precautions

■ Motor Insulation Test

Perform insulation test when the motor is used for the first time, or when it is reused after storing for a long time, or in a regular checkup, aiming to prevent the poor insulation of motor windings from damaging the controller. The motor must be disconnected from the controller during the insulation test. A 500 V Mega-Ohm meter is recommended so that the insulation resistance is not less than 5 MΩ.

■ Motor Heat and Noise

The output voltage of the controller is PWM wave with certain harmonic wave, and therefore, the motor temperature, noise and vibration will slightly rise compared with the condition of being operated by a power frequency drive.

■ Voltage-Sensitive Device or Capacitor at Output Side of the Controller

The capacitor for improving power factor or voltage-sensitive resistor for lightning protection must not be installed at the controller's output side because the controller outputs PWM wave. Otherwise, the controller may suffer transient over-current or even be damaged.

■ Usage When External Voltage Is out of Rated Voltage Range

If external voltage is out of the allowable voltage range specified by the manual, the controller components may be damaged. If required, use corresponding voltage step-up or step-down device.

■ Lightning Strike Protection

A lightning strike protection device is installed inside the controller. The user needs to add a lightning protection device to the front end of the controller in places with frequent lightning strikes.

■ Altitude and De-rating

In places where the altitude is above 1000 m and the cooling effect gets worse due to rare air, it is necessary to de-rate the controller. Contact Inovance for detailed technical support.

■ Disposal

The electrolytic capacitors in the main circuit and PCB board may explode when they are burnt. Poisonous gas is generated when the plastic parts are burnt. Treat them as ordinary industrial waste.

■ About Adaptable Motor

1. The controller is adapted to squirrel-cage asynchronous motor and AC PMSM. Select the proper controller according to the motor nameplate.
2. To reach better control result, perform motor tuning based on actual conditions. For a PMSM, motor tuning is mandatory.

The controller alarms or even be damaged when short-circuit of the cable or inside the motor occurs. Therefore, perform insulation short-circuit test at the initial installation or during routine maintenance. During the test, make sure that the controller is disconnected from the testing parts.

Chapter 2 Product Information

2.1 Designation Rules and Nameplate

2.1.1 Designation Rules

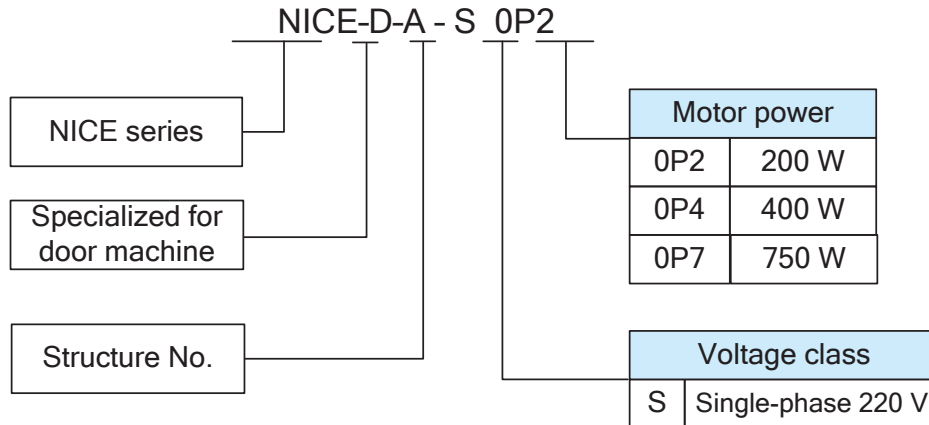

Model	Input Voltage	Power Capacity (kVA)	Input Current (A)	Output Current (A)	Adaptable Motor (W)
NICE-D-A-S0P2	Single-phase 200 V -15% to 20%	4.0	5.8	5.1	2.2
NICE-D-A-S0P4		5.9	10.5	9.0	3.7
NICE-D-A-S0P7		8.9	16.0	15.0	5.5

2.1.2 Nameplate

MODEL	NICE-D-A-S0P2
POWER	200W
INPUT	1PH AC220V 2.7A 50Hz/60Hz
OUTPUT	3PH AC0V-220V 1.3A 0Hz-99Hz
S/N	

2.2 Technical Specifications

Item		Specifications
Performance control	Maximum output frequency	99.00 Hz
	Speed range	1:50 (SVC), 1: 1000 (FVC)
	Speed stability	±0.5% (SVC), ±0.05% (FVC),

Item		Specifications
	Startup torque	1 Hz/150% (SVC), 0 Hz/180% (FVC)
	Frequency resolution	0.01 Hz
	Current resolution	0.01 A
	Carrier frequency	2 kHz–16 kHz
Main functions	For AC asynchronous motor, both static tuning and dynamic tuning are supported. For AC PMSM, no-load tuning, with-load tuning and encoder zero-point position are supported.	
	For feedback vector control (FVC) on the AC PMSM using a common ABZ encoder, open-collector output or push-pull output is supported.	
	Functions such as automatic torque boost, manual torque boost and over-excitation are supported in the sensorless vector control (SVC).	
	The direct stop function (under development) is supported in distance control.	
	Door width tuning is supported	
	Automatic demonstration is supported.	
	Automatic identification upon hindering is supported.	
Protection functions	The over-load protection (150% of rated current for 1 minute, 180% of rated current for 1 second) is supported.	
	The protections on over-voltage, under-voltage, over-current output phase loss and inter-phase short-circuit are supported.	
Environment	Installation location	Indoors and free from direct sunlight, dust, corrosive gas, combustible gas, oil mist, vapor, drip and salt
	Altitude	Lower than 1000m Derate the controller if the altitude is above 1000m.
	Ambient temperature	-10°C to +40°C Derate the controller if ambient temperature is from 45°C to 50°C.
	Humidity	Less than 95%RH, without condensing
	Vibration	<5.9m/s ² (0.6g)
	Storage temperature	-20°C to +60°C
	Cooling method	Natural cooling for the controller of 0.2 kW Forced air cooling for the controller of 0.4 kW and 0.75 kW
	Ingress protection	IP20
	Storage location	Indoors, clean and dry
	Transportation	Packed in standard box and transported by coach, train, aircraft and ship.
	Vibration during transportation	15m/s ² (1.5g) when SIN vibration is 9 Hz to 200 Hz

2.3 Physical Appearance and Mounting Hole Dimensions

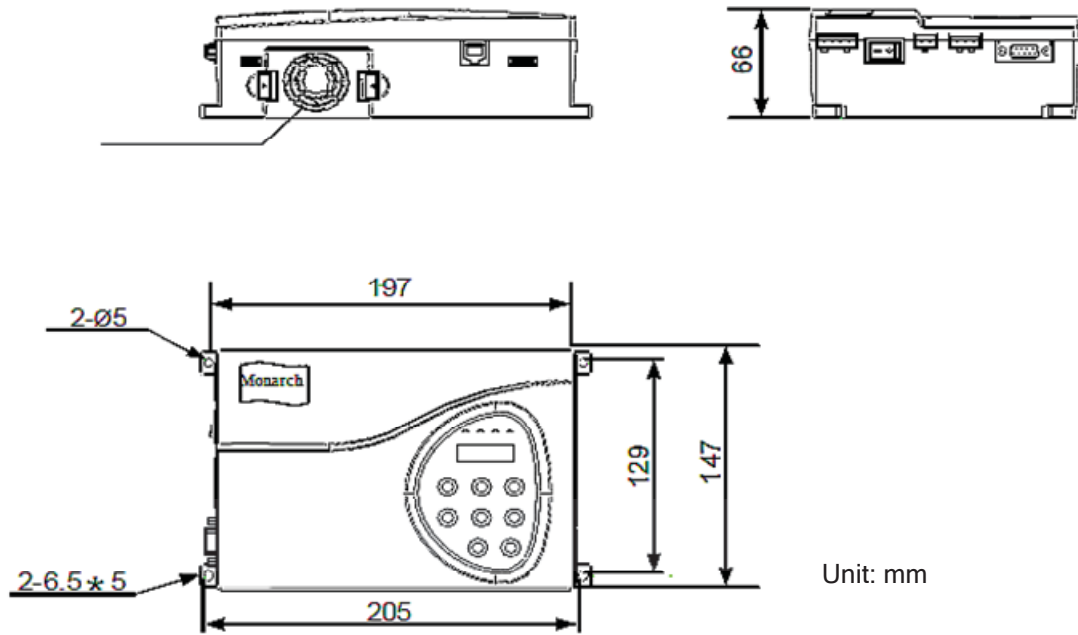

2.4 Routine Repair and Maintenance of the Controller

2.4.1 Routine Maintenance

The influence of the ambient temperature, humidity, dust and vibration cause aging of the devices in the controller, which may cause potential fault of the controller or reduce the service life of the controller. Therefore, it is necessary to carry out routine and periodic maintenance.

Note

The filter capacitor still has residual voltage after the power supply is cut off. Thus, do not repair or maintain the controller immediately. Wait at least 10 minutes and then ensure that the bus voltage measured by multimeter is not higher than 36 V.

Routine maintenance involves:

- Whether the motor sounds abnormally during running.
- Whether the motor has vibration during running.
- Whether the installation environment of the controller changes.
- Whether the controller's cooling fan works normally.
- Whether the controller overheats.

Routine cleaning involves:

- The controller is kept clean all the time.
- The dust on the surface of the controller must be effectively removed, to prevent the dust, especially metal dust, from entering the controller.

- The oil stain on the inverter's cooling fan must be effectively removed.

2.4.2 Periodic Inspection

Please perform periodic inspection on places where the inspection is difficult during running of the controller. Periodic inspection involves:

- Check and clean the air duct.
- Check whether the screws become loose.
- Check whether the controller is corroded.
- Check whether the wiring terminals have arc signs.
- Perform main circuit insulation test.

Note

Before measuring the insulating resistance with megameter (500VDC megameter recommended), disconnect the main circuit from the controller. Do not use the insulating resistance meter to test the insulation of the control circuit. High voltage test is unnecessary because it has been completed before delivery.

2.4.3 Replacement of Wearing Parts

The wearing parts of the controller are the cooling fan and filter electrolytic capacitor. Their service life is related to the operating environment and maintenance status. Generally, the service life is shown as follows:

Part	Service Life	Possible Damage Cause	Judging Criteria
Fan	2 to 3 years	<ul style="list-style-type: none"> ● Bearing worn ● Blade aging 	<ul style="list-style-type: none"> ● Whether there is crack on the blade ● Whether there is abnormal vibration noise upon startup
Electrolytic capacitor	4 to 5 years	<ul style="list-style-type: none"> ● Input power supply in poor quality, ● High ambient temperature ● Frequent load jumping ● Electrolytic aging 	<ul style="list-style-type: none"> ● Whether there is liquid leakage. ● Whether the safe valve has projected. ● Measure the static capacitance. ● Measure the insulating resistance.

2.4.4 Storage of the Controller

For storage of the controller, pay attention to the following two aspects:

1. Pack the controller with the original packing box provided by Inovance.
2. Long-term storage will degrade the electrolytic capacitor. Thus, the controller must be

powered up once every 2 years, each time lasting at least 5 hours. The input voltage must be increased slowly to the rated value with the regulator.

2.5 Optional Parts (Selection of Braking Resistor)

You need to select the braking resistor in high-inertia applications such as cold storage door. Braking resistor is unnecessary in the elevator door control applications.

Controller Model	Recommended Power	Recommended Resistance
NICE-D-A-S0P2	80 W	$\geq 250 \Omega$
NICE-D-A-S0P4	80 W	$\geq 250 \Omega$
NICE-D-A-S0P7	80 W	$\geq 150 \Omega$

Chapter 3 Electrical Installation

This chapter introduces the position, specification and wiring method of input/output (I/O) terminals.

3.1 Installation Environment

Item	Requirement
Ambient temperature	-10°C to 50°C
Heat dissipation	Mount the controller on the surface of incombustible objects with sufficient room for heat dissipation. Install the controller on the base with screws vertically.
Mounting location	Free from direct sunlight, high humidity and condensation
	Free from corrosive, explosive and flammable gas
	Free from oil dirt, dust and metal powder

3.2 Electrical Installation

3.2.1 Selection of Peripheral Electrical Devices

Controller Model	MCCB (A)	Contactors (A)	Main Circuit Conducting Cable (mm)
NICE-D-A-S0P2	10	10	2.5
NICE-D-A-S0P4	16	10	2.5
NICE-D-A-S0P7	16	10	2.5

3.2.2 Description of Peripheral Electrical Devices

Electrical Device	Mounting Location	Function Description
MCCB	Connecting to the controller's power supply	It is used to cut off the controller's power supply and provide short circuit protection.
AC input reactor	Input side of the system	<ol style="list-style-type: none"> 1. Improve the power factor of the input side. 2. Eliminate the higher harmonics of the input side effectively, 3. Protect the rectifier bridge effectively. 4. Eliminate the input current unbalance caused by inter-phase unbalance.
AC output reactor	Between the controller output side and the motor, close to the controller	If the controller is more than 100 m far away from the motor, install the AC output reactor.

3.3 Description of Terminals

3.3.1 Terminal Arrangement of the Control Circuit

+24V	PGA	PGB	PGZ	COM	DI1	DI2	DI3	DI4	COM	DI5	DI6	DI7	DI8	COM	+24V
------	-----	-----	-----	-----	-----	-----	-----	-----	-----	-----	-----	-----	-----	-----	------

MP24	MCOM	CAN+	CAN-	485+	485-	CZA1	GND
------	------	------	------	------	------	------	-----

TA1	TC1	TB1	TA2	TC2	TB2	TA3	TC3	TB3	
-----	-----	-----	-----	-----	-----	-----	-----	-----	---

3.3.2 Terminal Arrangement of Main Circuit

	\	L1	L2
---	---	----	----

P	PB
---	----

U	V	W
---	---	---

3.3.3 Description of Control Circuit Terminals

Type	Terminal	Name	Function Description
Communication	485+	Positive end of Modbus differential signal	Standard Modbus communication interface The shielded twisted pair cable is suggested.
	485-	Negative end of the Modbus differential signal	
	CAN+	Positive end of CAN bus differential signal	CAN bus communication interface The shielded twisted pair cable is suggested.
	CAN-	Negative end of CAN bus differential signal	
Digital input (DI)	DI1-DI8	DI terminals	<ol style="list-style-type: none"> Optical coupling isolation input, low level valid Input voltage range: 0VDC-30VDC Input impedance: 3.3k
Internal 24 V power	+24V	Externally connecting to the 24 V power supply	<ol style="list-style-type: none"> It is used as power supply for contactless switch or encoder. Max. output current: 200 mA
	COM	24 V power supply common terminal	It is isolated from the GND terminal internally.
Encoder input	PGA	Encoder phase A	Open-collector output or push-pull output
	PGB	Encoder phase B	
	PGZ	Encoder signal Z	
Analog input (AI)	CZA1	Weighing AI	Input voltage range: DC 0 V–10 V
	GND		

Type	Terminal	Name	Function Description
External 24V power	MP24	External 24 V power supply	External power supply for communication and analog
	MCOM	External power supply common terminal	
Relay output & shielded grounding	TA1/TB1/TC1 TA2/TB2/TC2 TA3/TB3/TC3	Relay output	<ol style="list-style-type: none"> TA-TB: normally closed (NC), TA-TC: normally open (NO); contact capacity: 250 VAC/3 A and 30 VDC/1 A Contact and control circuit insulation voltage class: 2.5 kVAC

3.3.4 Description of Main Circuit Terminals

Terminal	Name	Description
L1, L2	Single-phase power supply input terminals	Used for input of single-phase AC 220 V power supply.
P, PB	Connecting terminals of braking resistor	Connected to a braking resistor.
U, V, W	Controller output terminals	Connected to a three-phase motor.
	Grounding terminal	Used for grounding.

3.4 Other Interfaces

The interface RJ45 for parameter copy and software maintenance is provided.

The user can easily configure parameters for controllers in batches by means of this interface using specialized parameter copy operation panel.

Chapter 4 Operation and Trial Running

4.1 Operation Panel

You can modify the parameters, monitor the working status and run or stop the controller by operating the operation panel shown as below:

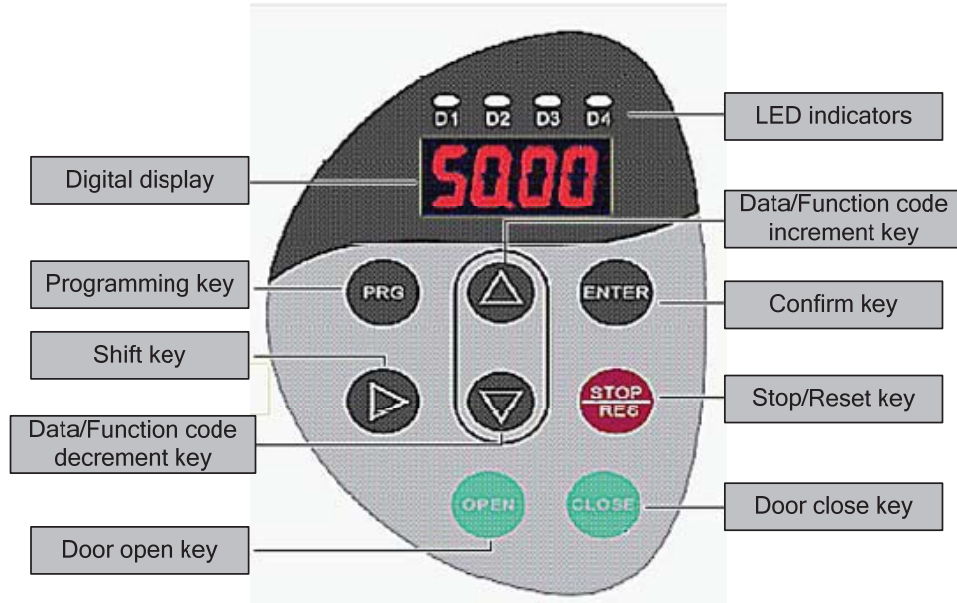

4.1.1 Description of LED Indicators

For details, refer to Chapter 7 Application and Commissioning.

Indicator	Meaning of LED Indicator ON at Stop		Meaning of LED Indicator ON During Running
	Speed Control	Distance Control	
D1	DI1 signal valid	DI1 signal valid	External door close command
D2	DI2 signal valid	Phase A and B signal correct	During door close
D3	DI3 signal valid	Phase Z signal valid	During door open
D4	DI4 signal valid	DI4 signal valid	External door open command

4.1.2 Description of Keys on the Operation Panel

Key	Name	Function
PRG	Programming key	Enter or exit Level I menu.
ENTER	Confirm key	Enter the menu interfaces level by level, and confirm the parameter setting.
STOP/RES	Stop/Reset key	Press this key to stop the running in the running state and reset the operation in the fault state.

▷	Shift key	Select the displayed parameters in turn in the stop or running state, and can select the digit to be modified when modifying parameters.
△	Increment key	Increase data or function code.
▽	Decrement key	Decrease data or function code.
OPEN	Door open key	Open the door in the operation panel operation mode.
CLOSE	Door close key	Close the door in the operation panel operation mode.

3.3 Basic Operations of the Controller

4.2.1 Operation Procedure of the Three-Level Menu

The operation panel of the NICE900 adopts three-level menu, convenient for quick querying and modification of parameters.

The three-level menu consists of function code group (Level I), function code (Level II), and function code setting value (level III), shown as below:

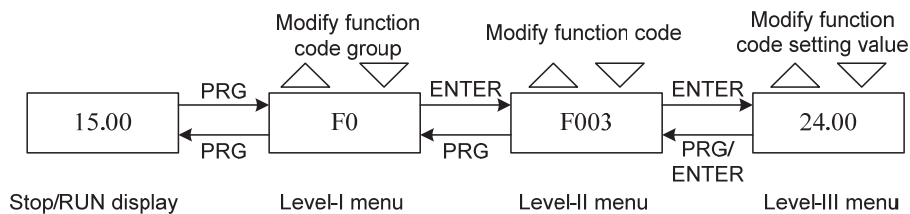

You can return to Level II from Level III by pressing PRG or ENTER.

- After you press ENTER, the system saves parameter setting first, and then goes back to Level II and shifts to the next function code.
- After you press PRG, the system does not save parameter setting, but directly returns to Level II and keeps staying at the current function code.

Here is an example of changing the value of F0-04 to 15.00 Hz:

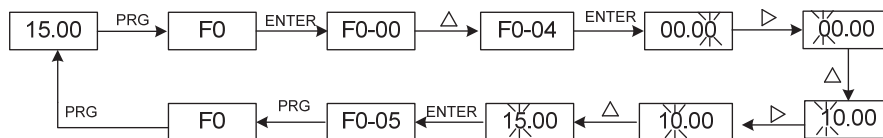

In Level III menu, if the parameter has no blinking digit, it means that the parameter cannot be modified. This may be because:

- Such function code is only readable, such as actually detected parameter and running record parameter.
- Such function code cannot be modified in the running state and can only be changed at stop.

4.2.2 Reading Fault Information

When a fault occurs on the controller, the error code of the fault is displayed on the operation panel. This helps you to find the cause of the fault and rectify the fault quickly.

The controller saves the error codes of the latest four faults. The frequency, current, bus voltage and DI/DO status at the latest fault are recorded.

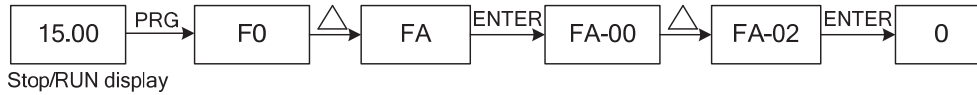

4.2.3 Viewing Information Displayed at Running or Stop

In the stop/running state without fault, you can query the parameters displayed at running or stop by means of the setting of FA-00/FA-01 and shift key ▷, shown as below:

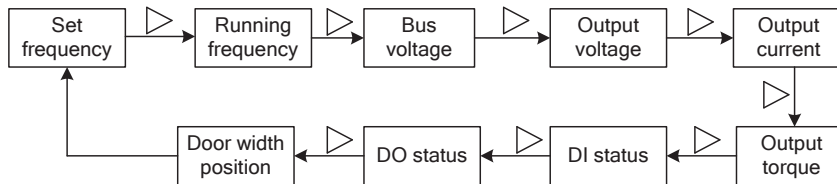

4.2.4 Setting the Password

To protect the parameters more effectively, the NICE900 provides user password protection function.

Here is an example of changing the password to 1234, shown as below:

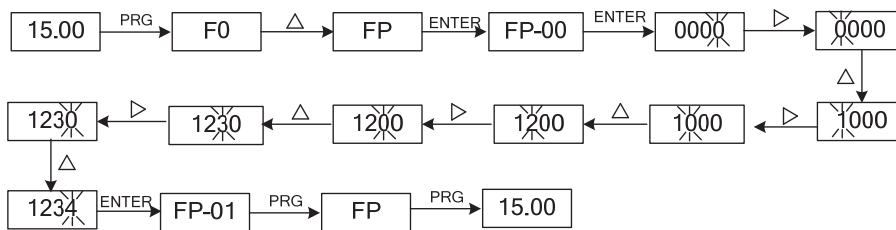

After you set the user password (FP-00 is set to a non-zero value), when you press the PRG key to enter the function code editing state, the system displays "-----" for password authentication. You can enter the editing state only after entering the correct user password.

For factory parameters, you can modify these parameters only after entering the correct factory password. Do not modify the setting of factory parameters, because improper setting causes system instability or abnormality.

In the password protection unlocked status, you can modify the user password at any time. The system takes the value that you enter for the last time as the user password. To cancel the password protection function, enter the password and set FP-00 to 0. If FP-00

is a non-zero value at power-on, the parameters are protected with password.

Chapter 5 Function Code Table

5.1 Description of Function Codes

The NICE900 series door machine controller has a total of 13 groups of function codes, namely, F0 to F9, FA, FF and FP. FX-YZ in this manual indicates the function code whose function code group is "X" and whose function code is "YZ". For example, F3-02 indicates function code "2" in group F3.

To facilitate the setting of the function codes, the operation panel adopts three-level menu. The function code group corresponds to Level-I menu, function code corresponds to Level-II menu, and the setting value corresponds to Level-III menu.

The symbols in the function code table are described as follows:

"☆": The parameter can be modified when the NICE900 is in either stop or running state.

"★": The parameter cannot be modified when the NICE900 is in the running state.

"●": The parameter is the actually measured value and cannot be modified.

"*": The parameter is factory parameter and can be set only by the manufacturer.

The controller performs automatic check on the modification property of the parameters to avoid misoperations.

"Default Value" indicates the value after parameter update when you restore factory settings, but the actually detected parameter values or recorded values are not updated.

To protect the parameters more effectively, the NICE900 provides the password protection.

5.2 Function Code Table

After pressing the PRG key and then the UP/DOWN key, the Level-I menu is displayed, corresponding to the following function code groups:

Group F0: Basic Parameters	Group F7: Distance Control Parameters
Group F1: Motor Parameters	Group F8: Auxiliary Parameters
Group F2: Performance Control Parameters	Group F9: Auxiliary Parameters
Group F3: Door Open Running Curve Parameters	Group FA: Display and Fault Parameters
Group F4: Door Close Running Curve Parameters	Group FF: Factory Parameters (Reserved)

Group F5: Door Open/Close Auxiliary Parameters Group FP: Display and Fault Parameters

Group F6: Distance Control Parameters

Note

The default value of some parameters is different from the default in the following table when the controller controls PMSM.

Function Code	Parameter Name	Setting Range	Min. Unit	Default	Property
Group F0: Basic Parameters					
F0-00	Control mode	0, 1	1	1	★
F0-01	Door open/close mode selection	0, 1	1	1	★
F0-02	Command source selection	0, 1, 2, 3	1	0	★
F0-04	Running frequency in operation panel control mode	0.00 to F1-04	0.01 Hz	5.00 Hz	☆
F0-05	Input point quick setting	0–2	1	1	★
F0-06	Speed at low-speed running	0.00 to F1-04	0.01 Hz	5.00 Hz	☆
F0-07	Carrier frequency	2.0–16.0 kHz	0.1 kHz	8.0 kHz	☆
Group F1: Motor Parameters					
F1-00	Motor type selection	0–2	0.1 kHz	8.0 kHz	★
F1-01	Rated power	0–750 W	1	1	★
F1-02	Rated voltage	0–250 V	1 W	Model dependent	★
F1-03	Rated current	0.001–9.900 A	1 V	100 V	★
F1-04	Rated frequency	1.00–99.00 Hz	0.001 A	Model dependent	★
F1-05	Rated rotating speed	0–9999 RPM	0.01 Hz	24.00 Hz	★
F1-06	Stator phase resistance of PMSM	0.00–99.99 Ω	0.01 Ω	Model dependent	★
F1-07	Rotor phase resistance of asynchronous motor	0.00–99.99 Ω	0.01 Ω	Model dependent	★
F1-08	Leakage inductance of asynchronous motor	0.0–99.99 mH	0.01 mH	Model dependent	★
F1-09	Mutual inductance of	0–999.9 mH	0.1 mH	Model	★

Function Code	Parameter Name	Setting Range	Min. Unit	Default	Property
	asynchronous motor			dependent	
F1-10	No-load excitation current of asynchronous motor	0.001–9.900 A	0.001 A	Model dependent	★
F1-11	D-shaft inductance of PMSM	0.0–999.9 mH	0.1 mH	Model dependent	★
F1-12	Q-shaft inductance of PMSM	0.0–999.9 mH	0.1 mH	Model dependent	★
F1-13	Counter EMF of PMSM	0–250 V	1 V	Model dependent	★
F1-14	Encoder zero-point position of PMSM	0.0–359.9°	0.1°	Model dependent	★
F1-15	Real-time angle of PMSM	0.0–359.9°	0.1°	Model dependent	•
F1-16	Motor tuning	0–5 (asynchronous motor: 1,2, 5; PMSM: 3, 4, 5)	1	0	★
Group F2: Performance Control Parameters					
F2-00	Speed loop proportional gain 1	0–100	1	15	☆
F2-01	Speed loop integral time 1	0.01–10.00s	0.01s	1.00s	☆
F2-02	Switchover frequency 1	0.00 to F2-05	0.01 Hz	5.00 Hz	☆
F2-03	Speed loop proportional gain 2	0–100	1	15	☆
F2-04	Speed loop integral time 2	0.01–10.00s	0.01s	1.00s	☆
F2-05	Switchover frequency 2	F2-02 to F1-04	1	30	☆
F2-06	Current loop proportional gain	10–500	1	120	☆
F2-07	Current loop integral gain	10–500	1	50	☆
F2-08	Slip compensation coefficient	50%–200%	1%	100%	☆
F2-09	Inertia compensation	0–9999	1	0	★
F2-10	Torque boost	0.0%–30.0%	0.1%	8.0%	☆
F2-11	Over-excitation gain	0–200	1	64	☆
F2-12	Initial position inference method	0–2	1	1	★
F2-13	Feedback speed filter level	0–20	1	0	☆
F2-14	PPR of the encoder	1–9999	1	2048	★

Function Code	Parameter Name	Setting Range	Min. Unit	Default	Property
F2-14	Encoder direction selection	0, 1	1	1	★
Group F3: Door Open Running Curve Parameters					
F3-00	Door open startup low speed	0.00 Hz to F3-03	0.01 Hz	5.00 Hz	☆
F3-01	Door open startup acceleration time	0.1–999.9s	0.1s	1.0s	☆
F3-02	Door open startup low speed running time in speed control	0.1–999.9s	0.1s	1.0s	☆
F3-03	Door open high speed	0.00 Hz to F1-04	0.01 Hz	15.00 Hz	☆
F3-04	Door open acceleration time	0.1-999.9s	0.1s	2.0s	☆
F3-05	Door open ending low speed	0.00Hz to F3-03	0.01 Hz	3.00Hz	☆
F3-06	Door open deceleration time	0.1–999.9s	0.1s	1.5s	☆
F3-07	Door open limit torque switchover point	0.0%–150.0%	0.1%	50.0%	☆
F3-08	Door open limit holding torque	0.0%–150.0%	0.1%	50.0%	☆
F3-09	Door open hindered torque	0.0%–150.0%	0.1%	80.0%	☆
F3-10	Door open startup torque	0.0% to F3-09	0.1%	0.0%	★
F3-11	Door open hindered judging time	0–9999 ms	1 ms	0ms	☆
F3-12	Door open limit low speed	0.00-F303	0.01 Hz	3Hz	☆
Group F4: Door Close Running Curve Parameters					
F4-00	Door close startup low speed setting	0.00 Hz to F4-03	0.01 Hz	4.00 Hz	☆
F4-01	Door close startup acceleration time	0.1–999.9s	0.1s	1.0s	☆
F4-02	Door close startup low speed running time in speed control	0.1–999.9s	0.1s	1.0s	☆
F4-03	Door close high speed setting	0.00 Hz to F1-04	0.01 Hz	12.00 Hz	☆
F4-04	Door close acceleration time	0.1–999.9s	0.1s	2.0s	☆
F4-05	Door close ending low speed setting	0.00 Hz to F4-03	0.01 Hz	2.00 Hz	☆
F4-06	Door close deceleration time	0.1–999.9s	0.1s	1.5s	☆
F4-07	Door close limit low speed setting	0.0 to F4-03	0.01 Hz	1.00 Hz	☆

Function Code	Parameter Name	Setting Range	Min. Unit	Default	Property
F4-08	Door close limit low speed running time	0-9999 ms	1 ms	300 ms	☆
F4-09	Door vane retraction speed setting	0.00 to F4-03	0.01 Hz	2.00 Hz	☆
F4-10	Door vane retraction running time	0-9999 ms	1 ms	500 ms	☆
F4-11	Door close limit torque switchover point setting	0.0%-150.0%	0.1%	50.0%	☆
F4-12	Door close limit holding torque	0.0%-150.0%	0.1%	30.0%	☆
F4-13	Door close hindered torque	0.0%-150.0%	0.1	100.0%	★
F4-14	Door close hindered working method	0, 1	1	1	★
F4-15	Door close hindered judging time	0-9999 ms	1 ms	500 ms	☆
F4-16	Door close high speed setting at fire emergency	5.00 to F1-04	0.01 Hz	10.00 Hz	☆
F4-17	Door close hindered high speed setting	F4-18 to F1-04	0.01 Hz	12.00 Hz	☆
F4-18	Door close hindered low speed setting	0.00 Hz to F1-04	0.01 Hz	2.00 Hz	☆
F4-19	High-speed torque setting	0.00%-150.0%	0.1%	100.0%	☆
F4-20	Low-speed torque setting	0.00%-150.0%	0.1%	100.0%	☆
Group F5: Door Open/Close Auxiliary Parameters					
F5-00	Abnormality deceleration time	0.1-5.0s	0.1	0.3s	☆
F5-01	Door open time limit	0-9999s	1s	30.0s	☆
F5-02	Door close time limit	0-9999s	1s	0s	☆
F5-03	Low-speed running time limit	0-9999s	1s	0s	☆
F5-04	Delay of external door open command	0-9999s	1s	60s	☆
F5-05	Delay of external door close command	0-9999s	1s	60s	☆
F5-06	Door open curve selection	0, 1	1	1	★
F5-07	Start segment time of the door open acceleration S curve	10.0%-50.0% (acceleration/deceleration time, start segment + rising	0.1%	20.0%	★

Function Code	Parameter Name	Setting Range	Min. Unit	Default	Property
		segment \leq 90%)			
F5-08	Rising segment time of the door open acceleration S curve	10.0%–80.0% (acceleration/deceleration time, start segment + rising segment \leq 90%)	0.1%	60.0%	★
F5-09	Start segment time of the door open deceleration S curve	10.0%–50.0% (acceleration/deceleration time, start segment + falling segment \leq 90%)	0.1%	20.0%	★
F5-10	Falling segment time of the door open deceleration S curve	10.0%–80.0% (acceleration/deceleration time, start segment + falling segment \leq 90%)	0.1%	60.0%	★
F5-11	Door close curve selection	0, 1	1	1	★
F5-12	Start segment time of the door close acceleration S curve	10.0%–50.0% (acceleration/deceleration time, start segment + rising segment \leq 90%)	0.1%	20.0%	★
F5-13	Rising segment time of the door close acceleration S curve	10.0%–80.0% (acceleration/deceleration time, start segment + rising segment \leq 90%)	0.1%	60.0%	★
F5-14	Start segment time of the door close deceleration S curve	10.0%–50.0% (acceleration/deceleration time, start segment + falling segment \leq 90%)	0.1%	20.0%	★
F5-15	Falling segment time of the door close deceleration S curve	10.0%–80.0% (acceleration/deceleration time, start segment + falling segment \leq 90%)	0.1%	60.0%	★
F5-16	Speed deviation setting	0%–80%	0%	50%	☆
F5-17	Time for determining speed deviation too large	0–5000 ms	1 ms	400 ms	☆
F5-18	Door close steady speed delay	0–9999 ms	1 ms	400 ms	★
Group F6: Distance Control Parameters					
F6-00	Door width tuning function selection	0, 1	1	0	★
F6-01	Door width tuning speed	0 to F0-02 (max. frequency)	0.01 Hz	3.00 Hz	☆

Function Code	Parameter Name	Setting Range	Min. Unit	Default	Property
F6-02	Low bit of door width pulse	0-9999	1	0	★
F6-03	High bit of door width pulse	0-9999	1	0	★
F6-04	Low-speed running distance of door open start in distance control	0.0%-30.0%	0.1%	10.0%	☆
F6-05	Door open deceleration point in distance control	60.0%-90.0%	0.1%	70.0%	☆
F6-06	Door open limit point in distance control	80.0%-99.0%	0.1%	96.0%	☆
F6-07	Low-speed running distance of door close start in distance control	0.0%-30.0%	0.1%	10.0%	☆
F6-08	Door close deceleration point in distance control	60.0%-90.0%	0.1%	70.0%	☆
F6-09	Door close limit point in distance control	80.0%-99.0%	0.1%	96.0%	☆
F6-10	Output torque display	0.0-1-80.0%	0.1%	0.0%	☆
F6-11	Low bit of the door open limit switch's position	0-9999	1	0	★
F6-12	High bit of the door open limit switch's position	0-9999	1	0	★
F6-13	Position of the door close limit switch	0-9999	1	0	★
F6-14	Torque setting for door width tuning or initial running	0.0%-150.0%	0.1%	80.0%	★
F6-15	Low bit of the pulse of door open deceleration point	0-9999	1	0	★
F6-16	High bit of the pulse of door open deceleration point	0-9999	1	0	★
F6-17	Low bit of the pulse of door close deceleration point	0-9999	1	0	★
F6-18	High bit of the pulse of door close deceleration point	0-9999	1	0	★
F6-19	Pulse at door open limit output	0.0%-99.99%	0.1%	0.0%	☆
F6-20	Pulse at door close limit output	0.0%-99.99%	0.1%	0.0%	☆
F6-21	Door position feedback pulse	0.0%-99.99%	0.1%	33.0%	☆

Function Code	Parameter Name	Setting Range	Min. Unit	Default	Property
Group F7: Distance Control Parameters					
F7-00	Door open limit holding time in demonstration mode	0.5–999.9s	0.1s	2.0s	★
F7-01	Door close limit holding time in demonstration mode	0.5–999.9s	0.1s	2.0s	★
F7-02	Times record of door open and close in demonstration mode	0–9999	1	0	☆
F7-03	Times setting of door open and close in demonstration mode	0–9999	1	0	☆
Group F8: Auxiliary Parameters					
F8-00	Software version	0.00–99.99	0.01	1.00	•
F8-01	Module temperature	0–100°C	0°C	0°C	•
F8-02	Automatic fault reset times	0–100	1	0	★
F8-03	Brake use ratio	0–100%	1%	100%	☆
F8-04	Accumulative operation time	0–9999h	1	0	★
F8-05	Reserved (working time: minutes)	0	1	0	★
F8-06	Accumulative running time	0–9999h	1	0	★
F8-07	Reserved (working time: minutes)	0	1	0	★
F8-08	Accumulative working time setting	0–9999h	1	0	★
F8-09	Accumulative operation time setting	0–9999h	1	0	★
F8-10	Auxiliary function selection	0–9999	1	12	★
F8-11	Fault function selection	0–9999	1	0	
F8-12	Drive function selection	0–9999	1	0	★
F8-14	Overload coefficient	0–10.00	0.01	2.00	☆
F8-16	Number of door machines	1, 2	1	1	★
Group F9: Auxiliary Parameters					
F9-00	Terminal filter time	0–100 ms	1 ms	20 ms	☆
F9-01	DI1 function selection	0: No function	1	0	★

Function Code	Parameter Name	Setting Range	Min. Unit	Default	Property
F9-02	DI2 function selection	1: Door open command sent by the system	1	0	★
F9-03	DI3 function selection	2: Door close command sent by the system	1	0	★
F9-04	DI4 function selection	3: External reset terminal signal	1	1	★
F9-05	DI5 function selection	4: Forbid terminal input during door open	1	2	★
F9-06	DI6 function selection	5: Forbid terminal input during torque holding	1	10	★
F9-07	DI7 function selection	6: Low-speed door close command			
F9-08	DI8 function selection	7: Fire-emergency input 8 to 109: Reserved 10/110: NO/NC input of light curtain signal 11/111: NO/NC input of safety edge signal 12/112: NO/NC input of door open limit signal 13/113: NO/NC input of door close limit signal 14/114: NO/NC input of door open deceleration signal 15/115: NO/NC input of door close deceleration signal 16/116: NO/NC input of door lock signal	1	6	★
F9-09	Relay output selection (TA1/TB1/TC1)	0: No function 1: Door open limit signal output 0	1	2	★
F9-10	Relay output selection (TA2/TB2/TC2)	2: Door close limit signal output 0	1	5	★
F9-11	Relay output selection (TA3/TB3/TC3)	3: Door open limit signal output 1 4: Door close limit signal output 1 5: Fault signal output 1 (Er26 is only a prompt)	1	1	★

Function Code	Parameter Name	Setting Range	Min. Unit	Default	Property
		rather than a fault.) 6: Reserved 7: Door open limit signal output 2 8: Door close limit signal output 2 9: Door lock signal output 10: Door re-open signal output 11: Hindering signal output 12: Door position feedback output			
Group FA: Display and Fault Parameters					
FA-00	Selection of running parameters displayed on LED	1-511	1	319	☆
FA-01	Selection of stop parameters displayed on LED	1-63	1	39	☆
FA-02	1st fault type	0-30	1	0	•
FA-03	1st fault prompt	0-9	1	0	•
FA-04	2nd fault type	0-30	1	0	•
FA-05	2nd fault prompt	0-9	1	0	•
FA-06	3rd fault type	0-30	1	0	•
FA-07	3rd fault prompt	0-9	1	0	•
FA-08	4th fault type	0-30	1	0	•
FA-09	4th fault prompt	0-9	1	0	•
FA-10	5th fault type	0-30	1	0	•
FA-11	5th fault prompt	0-9	1	0	•
FA-12	Bus voltage at occurrence of the latest fault	0-999.9 V	0.1 V	0 V	•
FA-13	Output current at occurrence of the latest fault	0-99.99 A	0.01 A	0.00 A	•
FA-14	Running frequency at occurrence of the latest fault	0-99.00 Hz	0.01 Hz	0.00 Hz	•
FA-15	Output torque at occurrence of the latest fault	0.0-180.0% (percentage of output torque to rated torque)	0.1%	0.0%	•

Function Code	Parameter Name	Setting Range	Min. Unit	Default	Property
FA-16	Input terminal status at occurrence of the latest fault	0–1023	1	0	●
FA-17	Output terminal status at occurrence of the latest fault	0–15	1	0	●
FA-18	Terminal status query	*	*	*	●
FA-19	Function input status query	*	*	*	●
FA-20	Function output status query	*	*	*	●
FA-21	Display control by switch	0–9999	1	0	☆
FA-22	Display 1	0–9999	1	0	●
FA-23	Display 2	0–9999	1	0	●
FA-24	Analog voltage display	0.00–10.1 V	0.01 V	0.00 V	●
FA-25	Low bit of current door position	0–9999	1	0	●
FA-26	High bit of current door position	0–9999	1	0	●
FA-27	Running status display	0–9999	1	0	●
FA-28	Door direction judgment	*	*	*	●
Group FF: Factory Parameters (Reserved)					
FF-00	Reserved	0	1	0	●
Group FP: Display and Fault Parameters					
FP-00	User password	0–9999	1	0	☆
FP-01	Parameter update	0–2	1	0	★
FP-02	Password for viewing parameters	0–9999	1	0	★

Chapter 6 Description of Function Codes

Group F0: Basic Parameters

Function Code	Parameter Name	Setting Range	Default	Min. Unit
F0-00	Control mode	0, 1	1	1

- 0: sensorless vector control (SVC)

It applies to common applications. The motor does not need an encoder. The control effect is less accurate compared with FVC. Do not adopt SVC in the applications where permanent magnet synchronous motor (PMSM) is used.

- 1: feedback vector control (FVC)

The motor is in coaxial connection with an encoder, and the encoder feeds back the motor's rotating speed signal. The pulses per revolution (PPR) of the encoder must be set properly.

Function Code	Parameter Name	Setting Range	Default	Min. Unit
F0-01	Door open/close mode selection	0, 1	1	1

- 0: Speed control

In the speed control mode, four travel switches need to be installed on the door. They are door open deceleration switch, door open limit switch, door close deceleration switch and door close limit switch.

The controller instructs deceleration from the deceleration point and judges the limit signal.

- 1: Distance control

In the distance control mode, door width pulses must be obtained through tuning. After relevant door open/close curve parameters are set, the controller instructs deceleration and judges the limit signal.

If DI is allocated with door open/close limit signal in group F9, the controller judges the limit signal.

Function Code	Parameter Name	Setting Range	Default	Min. Unit
F0-02	Command source selection	0, 1, 2, 3	0	1

- 0: Operation panel control mode

Run or stop the controller by operating the operation panel. When OPEN is pressed, the controller instructs forward rotation. When CLOSE is pressed, the controller instructs reverse rotation. When STOP/REG is pressed, the controller instructs stop.

In such control mode, the controller runs as a general controller and does not execute

the special door machine logics.

- 1: Door machine terminal control mode

The door open/close is controlled by the combination of DI statuses.

Door Open Command	Door Close Command	Running State
0	0	Stop
0	1	Door close
1	0	Door open
1	1	Door open

- 2: Door machine manual commissioning mode

Run or stop the controller by operating the operation panel. When OPEN is pressed, the controller instructs door open. When CLOSE is pressed, the controller instructs door close. When STOP/REG is pressed, the controller instructs stop.

- 3: Door machine automatic demonstration mode

It applies to the demonstration of door machine and factory trial running without the use of the controller. This mode can be set after you finish commissioning of the door machine running curve via the operation panel.

The door open/close demonstration can be repeated by pressing OPEN or CLOSE. The time interval and times of door open/close demonstration can be set in group F7. When STOP/REG is pressed, the controller instructs stop.

Note

- Door width tuning is valid only in the door machine manual commissioning mode (F0-02 = 2).
- Motor tuning is valid only in the operation panel control mode (F0-02 = 0).

Function Code	Parameter Name	Setting Range	Default	Min. Unit
F0-04	Running frequency in operation panel control mode	0.00 to F1-04	5.00 Hz	0.01 Hz

It is used to set the running frequency when the speed is input via operation panel.

Function Code	Parameter Name	Setting Range	Default	Min. Unit
F0-05	Input point quick setting	0-2	0	1

It is used to quickly set the signal feature of the limit switches and deceleration switches in the speed control (F0-01=0). When F0-05 is set to a non-zero value, the types of the corresponding input points are as follows:

F0-05=1	F0-05=2
F9-01=13 (door close limit NO input)	F9-01=113 (door close limit NC input)
F9-02=15 (door close acceleration NO input)	F9-02=115 (door close acceleration NC input)
F9-03=14 (door open deceleration NO input)	F9-01=113 (door open deceleration NC input)

F9-04=12 (door open limit NO input)	F9-01=113 (door open limit NC input)
-------------------------------------	--------------------------------------

Function Code	Parameter Name	Setting Range	Default	Min. Unit
F0-06	Speed at low-speed running	0.00 to F1-04	5.00 Hz	0.01 Hz

It is used to set the speed when the inspection input is valid or when the controller runs for the first time after power-on on condition that the distance control mode is used or the low-speed door close input is valid.

Function Code	Parameter Name	Setting Range	Default	Min. Unit
F0-07	Carrier frequency	2.0–16.0 kHz	8.0 kHz	0.1 kHz

It is used to adjust the controller's carrier frequency, aiming to reduce motor noise, avoid the resonance of the mechanical system, and reduce the leakage current to the earth and the interference generated by the controller.

When the carrier frequency is low, the current high harmonic output increases, the power loss of the motor increases, and the motor temperature rise also increases.

When the carrier frequency is high, the power loss of the motor declines, and the motor temperature rise also declines. However, the controller has an increase in power loss, temperature rise and interference.

Adjusting the carrier frequency will exert influences on the following aspects:

Carrier frequency	Low.....High
Motor noise	Large.....Small
Output current waveform	Bad.....Good
Motor temperature rise	High.....Low
Inverter temperature rise	Low.....High
Leakage current	Small.....Large
External radiation interference	Small.....Large

Group F1: Motor Parameters

Function Code	Parameter Name	Setting Range	Default	Min. Unit
F1-00	Motor type selection	0–2	1	1
F1-01	Rated power	0–750 W	Model dependent	1 W
F1-02	Rated voltage	0–250 V	100 V	1 V
F1-03	Rated current	0.001–9.900 A	Model dependent	0.001 A
F1-04	Rated frequency	1.00–99.00 Hz	24.00 Hz	0.01 Hz
F1-05	Rated rotating speed	0–9999 RPM	180 RPM	1 RPM

Set the parameters according to the motor nameplate. To ensure the desired vector control performance, you need to perform motor tuning. The tuning accuracy depends on correct setting of motor nameplate parameters.

Function	Parameter Name	Setting Range	Default	Min. Unit
----------	----------------	---------------	---------	-----------

Code				
F1-06	Stator phase resistance of PMSM	0.00–99.99 Ω	Model dependent	0.01 Ω
F1-07	Rotor phase resistance of asynchronous motor	0.00–99.99 Ω	Model dependent	0.01 Ω
F1-08	Leakage inductance of asynchronous motor	0.0–99.99 mH	Model dependent	0.01 mH
F1-09	Mutual inductance of asynchronous motor	0–999.9 mH	Model dependent	0.1 mH
F1-10	No-load excitation current of asynchronous motor	0.001–9.900 A	Model dependent	0.001 A
F1-11	D-shaft inductance of PMSM	0.0–999.9 mH	Model dependent	0.1 mH
F1-12	Q-shaft inductance of PMSM	0.0–999.9 mH	Model dependent	0.1 mH
F1-13	Counter EMF of PMSM	0–250 V	Model dependent	1 V
F1-14	Encoder zero-point position of PMSM	0.0–359.9°	Model dependent	0.1°
F1-15	Real-time angle of PMSM	0.0–359.9°	Model dependent	0.1°

To ensure the desired control performance, select an adaptable motor. If the motor power has great difference from the standard adaptable motor, the control performance may degrade.

Once the motor tuning is complete normally, the values of F1-06 to F1-14 are updated automatically. After asynchronous motor tuning and PMSM tuning are complete, the corresponding parameters are updated.

For an asynchronous motor, the NICE900 obtains the corresponding parameters through complete tuning or static tuning. If it is impossible to tune the motor onsite, manually input the value of these parameters according to the nameplate of the same type of motor. Each time the rated power (F1-01) is changed, the controller automatically resumes F1-06 to F1-10 to the default values.

For a PMSM, the NICE900 can obtain F1-06, F1-11, F1-12, F1-13 and F1-14 through complete tuning. After the rated power (F1-01) is changed, the corresponding parameters will not update.

Function Code	Parameter Name	Setting Range	Default	Min. Unit
F1-16	Motor tuning	0–5 (asynchronous motor: 1,2, 5; PMSM: 3, 4, 5)	0	1

Note

- Motor tuning can only be performed in the operation panel control mode (F0-02 = 0). Before motor tuning, set motor ratings (F1-00 to F1-05) and PPR of the encoder F2-14 correctly.
- In the case that PMSM is applied, if the motor/encoder is replaced or the installation of the encoder is changed before first-time running, motor tuning must be performed.
- PMSM running is prohibited before motor tuning succeeds. Otherwise, runaway may result. Avoid

locked-rotor during tuning. Otherwise, motor tuning fails.

- 0: No tuning

Tuning is prohibited.

- 1: Static tuning for asynchronous motor

It applies to the applications where complete tuning cannot be performed because the asynchronous motor must be connected with the load. The stator resistance, rotor resistance and leakage inductance are obtained from tuning. The no-load current and mutual inductance can be calculated.

- 2: Complete tuning for asynchronous motor

To ensure the controller's dynamic control performance, perform complete tuning, which requires the motor to be disconnected from the load.

The controller performs static tuning first and then accelerates to 80% of the motor rated frequency within the system default acceleration time of 2s. The controller keeps the frequency for a certain period and then decelerates to 0 within the 2s deceleration time.

- 3: No-load tuning for PMSM

The following parameters are obtained by tuning: "Encoder zero-point position of PMSM" (F1-14), "Stator phase resistance of PMSM" (F1-06), "D-shaft inductance of PMSM" (F1-11) and "Q-shaft inductance of PMSM" (F1-12).

For no-load tuning, the PMSM must be disconnected from the load. If not, "Encoder zero-point position of PMSM" (F1-14) is not accurate, which affects the motor's control performance.

The controller instructs slow door open/close according to the door open/close tuning command and instructs reverse running after a distance. Finally, the controller calculates the corresponding parameters and completes no-load tuning.

If Er20 fault occurs during tuning, the encoder input direction may be incorrect. Exchange the phases A and B of the encoder or the motor wiring and perform motor tuning again.

- 4: With-load tuning for PMSM

The following parameters are obtained by tuning: "Encoder zero-point position of PMSM" (F1-14), "Stator phase resistance of PMSM" (F1-06), "D-shaft inductance of PMSM" (F1-11) and "Q-shaft inductance of PMSM" (F1-12).

Compared with no-load tuning for PMSM, "Encoder zero-point position of PMSM" (F1-14) obtained here is less accurate. Therefore, perform no-load tuning for PMSM if possible.

If the door is in the close state, press OPEN to start tuning. If the door is in the completely open state, press CLOSE to start tuning. Perform the door open/close slowly at the target speed (25% of the rated motor power). Then the controller instructs reverse running. After three times of tuning, the controller obtains the values of relevant parameters. The with-load tuning ends.

After you press OPEN or CLOSE, if the door machine opens or closes the door and suffers locked-rotor, motor wiring or encoder wiring is abnormal. Correct the wiring and perform motor tuning.

After F1-16 is set correctly, press ENTER. Then "TUNE" is displayed and blinks. Press the OPEN or CLOSE key to start tuning. During tuning, press the STOP key to stop tuning. Once the tuning ends, F1-16 resumes to 0 automatically.

For more details on tuning, refer to Chapter 7 Application and Commissioning.

Group F2: Performance Control Parameters

Function Code	Parameter Name	Setting Range	Default	Min. Unit
F2-00	Speed loop proportional gain 1	0–100	15	1
F2-01	Speed loop integral time 1	0.01–10.00s	1.00s	0.01s
F2-02	Switchover frequency 1	0.00 to F2-05	5.00 Hz	0.01 Hz
F2-03	Speed loop proportional gain 2	0–100	15	1
F2-04	Speed loop integral time 2	0.01–10.00s	1.00s	0.01s
F2-05	Switchover frequency 2	F2-02 to F1-04	30	1

- If the running frequency is equal to or higher than F2-02 (switchover frequency 1), the speed loop PI parameters are F2-00 and F2-01.
- If the running frequency is equal to or higher than F2-05 (switchover frequency 2), the speed loop PI parameters are F2-03 and F2-04.
- If the running frequency is between F2-02 and F2-05, the speed loop PI parameters are the weighted average of F2-00, F2-01, F2-03 and F2-04, shown as below:

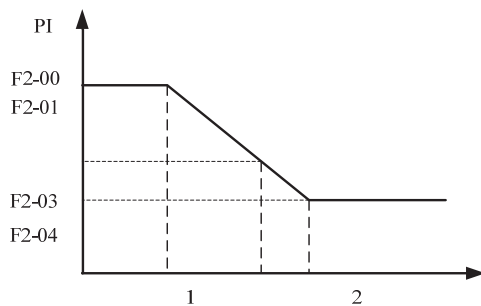

The speed dynamic response characteristics in vector control can be adjusted by setting the proportional gain and integral time of the speed regulator.

Increasing the proportional gain or reducing the integral time can accelerate the dynamic response of the speed loop. However, if the proportional gain is too large or the integral time is too small, it will cause the oscillation of the system.

■ Recommended Adjustment Method

If the factory settings cannot meet the requirement, fine tuning is suggested. Increase the proportional gain first so as to ensure no oscillation of the system, and then reduce the integral time to ensure that the system has quick responsiveness and small overshoot.

If both switchover frequency 1 (F1-02) and switchover frequency 2 (F1-05) are 0, only F2-03 and F2-04 are valid.

Note

Improper PI parameter setting may cause too large speed overshoot. Over-voltage fault may occur when the overshoot drops.

Function Code	Parameter Name	Setting Range	Default	Min. Unit
F2-06	Current loop proportional gain	10–500	120	1
F2-07	Current loop integral gain	10–500	50	1

F2-06 and F2-07 are current loop adjusting parameters in vector control. Generally, the customer does not need to adjust these two parameters because the desired control result can be result with their default value. The adjustment of the two parameters is the same as that of PI parameters.

Function Code	Parameter Name	Setting Range	Default	Min. Unit
F2-08	Slip compensation coefficient	50%–200%	100%	1%

It is used only in FVC mode. It affects the dynamic performance and load current of the motor and requires no adjustment generally.

Function Code	Parameter Name	Setting Range	Default	Min. Unit
F2-09	Inertia compensation	0–9999	0	1

It increases the system dynamic performance in FVC mode. The inertia compensation=system inertia multiplied by acceleration. Generally, the customer does not need to adjust the parameter. Just increase it properly in the applications where the door machine is too heavy.

Function Code	Parameter Name	Setting Range	Default	Min. Unit
F2-10	Torque boost	0.0%–30.0%	8.0%	0.1%

To compensate the low frequency torque characteristics of SVC, you can boost the output voltage of the controller at low frequency. If the torque boost is set to a too large value, the motor may overheat, and the controller may suffer over-current easily.

Effectively adjusting this parameter will avoid over-current at startup. For the relatively large load, it is recommended to increase this parameter. If it is set to 0.0, the controller will adopt auto torque boost.

Function Code	Parameter Name	Setting Range	Default	Min. Unit
F2-11	Over-excitation gain	0–200	64	1

The over-excitation gain can restrain the rise of bus voltage so as to avoid occurrence of over-voltage fault during the process of deceleration. Bigger the over-excitation gain is, better restraining result will be obtained.

Set the over-excitation gain to 0 in the applications where the inertia is small or where there is braking resistor. In the applications where the inertia is large, properly increase the over-excitation gain.

Function Code	Parameter Name	Setting Range	Default	Min. Unit
F2-12	Initial position inference method	0–2	1	1

- 1: Adopting pulses for inference
- 2: Adopting other inference method (under development)

Function Code	Parameter Name	Setting Range	Default	Min. Unit
F2-13	Feedback speed filter level	0–20	0	1

It is used to set the filter level of the encoder's feedback speed and requires no adjustment generally. In the applications where the interference is serious or the PPR of the encoder is less, if FVC is adopted, increase this parameter properly to as to stabilize the motor running.

Note

In the application where the motor is of small power or the load inertia is small, if the parameter is set to a too large value, serious motor overshoot or motor oscillation may result.

Function Code	Parameter Name	Setting Range	Default	Min. Unit
F2-14	PPR of the encoder	1–9999	2048	1

In the FVC mode, the PPR of the encoder must be set properly.

Function Code	Parameter Name	Setting Range	Default	Min. Unit
F2-14	Encoder direction selection	0, 1	1	1

When restoring factory parameters, it will resume to 0. Be cautious of using the function.

Group F3: Door Open Running Curve Parameters

Function Code	Parameter Name	Setting Range	Default	Min. Unit
F3-00	Door open startup low speed	0.00 Hz to F3-03	5.00 Hz	0.01 Hz
F3-01	Door open startup acceleration time	0.1–999.9s	1.0s	0.1s
F3-02	Door open startup low speed running time in speed control	0.1–999.9s	1.0s	0.1s
F3-03	Door open high speed	0.00 Hz to F1-04	15.00 Hz	0.01 Hz
F3-04	Door open acceleration time	0.1–999.9s	2.0s	0.1s
F3-05	Door open ending low speed	0.00Hz to F3-03	3.00Hz	0.01 Hz
F3-06	Door open deceleration time	0.1–999.9s	1.5s	0.1s

The travel switches of the door machine in the speed control are installed as below:

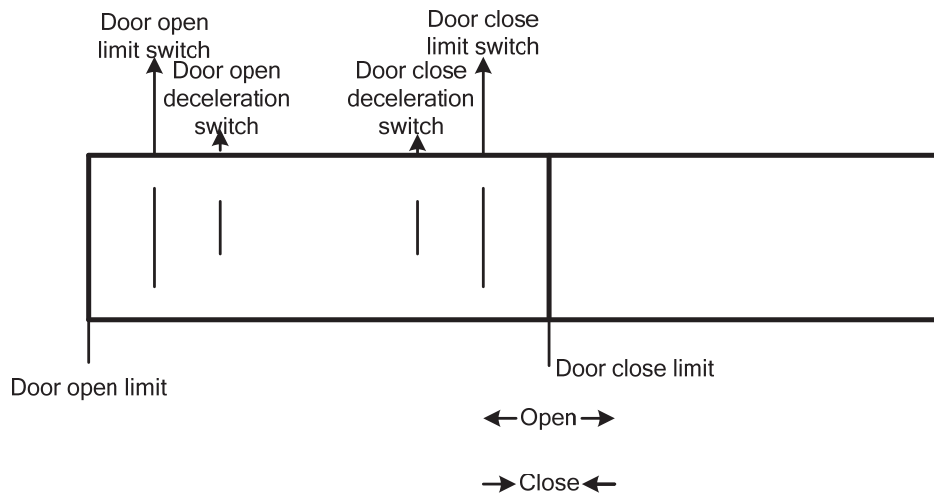

Set the parameters in group F3 related to speed control correctly. Set the deceleration switches and limit switches properly. The door open running curve in speed control is shown as below:

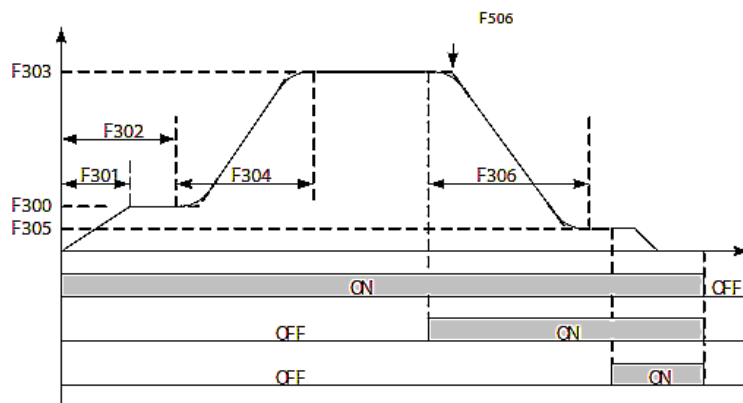

The door open process in speed control is as follows:

1. Once the door open command becomes valid, the door machine accelerates to the speed set in F3-00 after the acceleration time set in F3-01.
2. After the low-speed door open running time reaches the value set in F3-02, the door machine accelerates to the value set in F3-03. The acceleration time is the value set in F3-04.
3. Once the door open deceleration signal becomes valid, the door machine decelerates to the speed set in F3-05 to creep. The deceleration time is F3-06.
4. Once the door open limit signal becomes valid, the door machine decelerates to the speed set in F3-12 and enters door open holding status. The door open holding torque is the value set in F3-08.
5. If torque is required to keep up, increase F5-04.

- The dotted line part in the figure indicates the running curve when the Door open curve selection is set to Linear acceleration/deceleration (F5-06=1).

Set the parameters in group F6 related to distance control correctly. The door open running curve in distance control is shown as below:

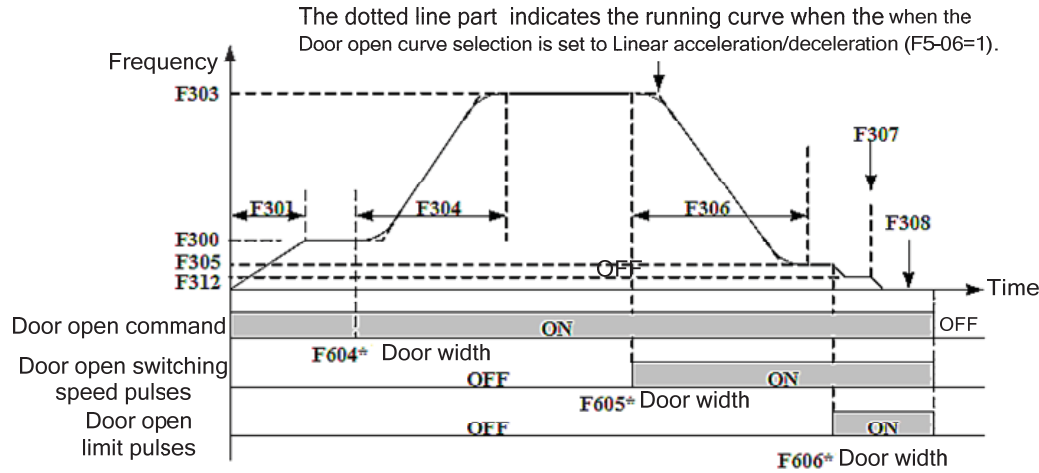

The door open process in distance control is as follows:

- Once the door open command becomes valid, the door machine accelerates to the speed set in F3-00 after the acceleration time set in F3-01.
- When the door open position reaches the F6-04*door width, the door machine accelerates to the value set in F3-03. The acceleration time is the value set in F3-04.
- When the door open position reaches the F6-05*door width, the door machine decelerates to creep. The creep speed is the value set in F3-05 and the deceleration time is the value set in F3-06.
- When the door open position reaches the F6-06*door width, the door machine enters the door open torque holding status at the speed set in F3-12. The holding torque is determined by F3-08. This moment the door position is reset to 100%.
- Once the command is cancelled, the torque holding ends. If torque holding needs to continue, increase the delay time set in F5-04.
- The dotted line part in the figure indicates the running curve when the when the Door open curve selection is set to Linear acceleration/deceleration (F5-06=1).

Function Code	Parameter Name	Setting Range	Default	Min. Unit
F3-07	Door open limit torque switchover point	0.0%–150.0%	50.0%	0.1%

It is only valid in distance control. After the set door open limit position is reached, if the output torque is greater than F3-07, the door width pulses are reset to 100% and the system enters door open limit torque holding status.

If the output torque is not greater than F3-07 after locked-rotor occurs, decrease F3-07

slightly (F3-07 smaller than the output torque) so as to ensure that the door width pulses can be reset.

Function Code	Parameter Name	Setting Range	Default	Min. Unit
F3-08	Door open limit holding torque	0.0%–150.0%	50.0%	0.1%

It is used to set the holding torque after the door open limit position is reached.

Function Code	Parameter Name	Setting Range	Default	Min. Unit
F3-09	Door open hindered torque	0.0%–150.0%	80.0%	0.1%

It is used to set the door open hindered torque during the process of door open. The upper limit of door open torque equals door open hindered torque plus 10.0%.

Function Code	Parameter Name	Setting Range	Default	Min. Unit
F3-10	Door open startup torque	0.0% to F3-09	0.0%	0.1%

It is used to set the torque at startup of door open so as to ensure the good startup result of the door machine. The startup torque equals F3-10 multiplied by rated motor torque.

Function Code	Parameter Name	Setting Range	Default	Min. Unit
F3-11	Door open hindered judging time	0–9999 ms	0 ms	1 ms

It is used to set the filter time when the door open is hindered. If it is set to 0, the door open hindered is not detected.

Function Code	Parameter Name	Setting Range	Default	Min. Unit
F3-12	Door open limit low speed	0.00 Hz to F3-03	3 Hz	0.01 Hz

It is used to set the target frequency at which the door machine runs when the door open limit signal is received or the pulses reach the door open limit requirement during the door open process so as to improve the efficiency of door re-open.

Group F4: Door Close Running Curve Parameters

Function Code	Parameter Name	Setting Range	Default	Min. Unit
F4-00	Door close startup low speed setting	0.00 Hz to F4-03	4.00 Hz	0.01 Hz
F4-01	Door close startup acceleration time	0.1–999.9s	1.0s	0.1s
F4-02	Door close startup low speed running time in speed control	0.1–999.9s	1.0s	0.1s
F4-03	Door close high speed setting	0.00 Hz to F1-04	12.00 Hz	0.01 Hz
F4-04	Door close acceleration time	0.1–999.9s	2.0s	0.1s
F4-05	Door close ending low speed setting	0.00 Hz to F4-03	2.00 Hz	0.01 Hz
F4-06	Door close deceleration time	0.1–999.9s	1.5s	0.1s

Set the parameters in group F4 related to speed control correctly. Set the deceleration switches and limit switches properly. The door close running curve in speed control is shown as below:

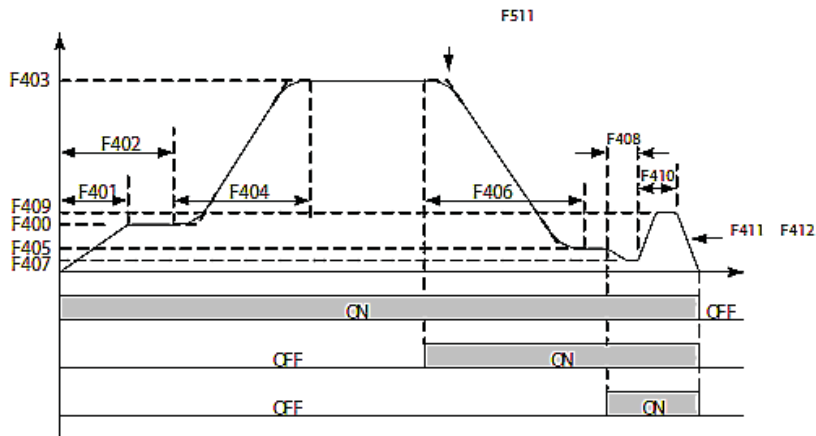

The door close process in speed control is as follows:

1. Once the door close command becomes valid, the door machine accelerates to the speed set in F4-00 after the acceleration time set in F4-01.
2. After the low-speed door close running time reaches the value set in F4-02, the door machine accelerates to the value set in F4-03. The acceleration time is the value set in F4-04.
3. Once the door close deceleration signal becomes valid, the door machine decelerates to the speed set in F4-05 to creep. The deceleration time is F4-06.
4. Once the door close limit signal becomes valid, the door machine enters the door close holding status. The door close holding torque is F4-12.
5. If torque is required to keep up, increase F5-05.
6. The dotted line part in the figure indicates the door close running curve when the when the Door open curve selection is set to Linear acceleration/deceleration (F5-06=1).

Note

For synchronous door vane, set F4-09 and F4-07 to the same value.

The door close running curve in distance control is shown as below:

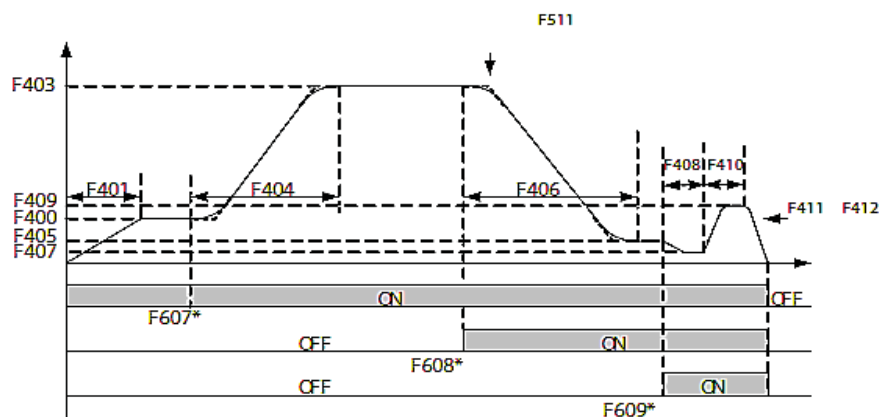

The door close process in distance control is as follows:

1. Once the door close command becomes valid, the door machine accelerates to the speed set in F4-00 after the acceleration time set in F4-01.
2. When the door close position reaches the F6-07*door width, the door machine accelerates to the value set in F4-03. The acceleration time is the value set in F4-04.
3. When the door close position reaches the F6-08*door width, the door machine decelerates to the speed set in F4-05. The deceleration time is the value set in F4-06.
4. When the door open position reaches the F6-09*door width, the door machine decelerates again to the speed set in F4-07. It is suggested F6-09 \geq 96.0%. If there are pulses lost during the process of door close, decrease F6-09. Perform door vane retraction via F6-20.
5. After the door vane retraction is complete and the rotor is locked, the door machine enters the torque holding stage. This moment the holding speed is F4-07 and the holding torque is F4-12. The door width is reset to 0.
6. Once the door close command becomes invalid, the torque holding ends. If torque holding needs to continue, decrease the delay time in F5-05.
7. Once the command is cancelled, the torque holding ends. If torque holding is required to continue, increase the delay time set in F5-04.
8. The dotted line part in the figure indicates the door running curve when the when the Door open curve selection is set to Linear acceleration/deceleration (F5-06=1).

Note

For synchronous door vane, set F4-09 and F4-07 to the same value.

Function Code	Parameter Name	Setting Range	Default	Min. Unit
F4-07	Door close limit low speed setting	0.0 to F4-03	1.00 Hz	0.01 Hz

It is used to set the target frequency at which the door machine runs when the controller receives the door close limit signal or the pulses reach the door close limit requirement during the process of door close.

Function Code	Parameter Name	Setting Range	Default	Min. Unit
F4-08	Door close limit low speed running time	0-9999 ms	300 ms	1 ms

The door machine runs at the low speed set in F4-07 after receiving the door close limit signal. When the running time equals or is longer than F4-08, the door machine enters the door vane retraction stage.

Function Code	Parameter Name	Setting Range	Default	Min. Unit
F4-09	Door vane retraction speed setting	0.00 to F4-03	2.00 Hz	0.01 Hz

It is used to set the running speed at the stage of door vane retraction during the process of door close.

Function Code	Parameter Name	Setting Range	Default	Min. Unit
F4-10	Door vane retraction running time	0-9999 ms	500 ms	1 ms

If the door vane retraction running time equals or is longer than F4-10, the door machine decelerates again.

Function Code	Parameter Name	Setting Range	Default	Min. Unit
F4-11	Door close limit torque switchover point setting	0.0%–150.0%	50.0%	0.1%

It is only valid in distance control. After the door vane is retracted, if the controller's output torque is greater than F4-11, the door width is reset to 0. Then the door machine enters the door close limit torque holding stage.

Function Code	Parameter Name	Setting Range	Default	Min. Unit
F4-12	Door close limit holding torque	0.0%–150.0%	30.0%	0.1%

It is used to set the door close holding torque after the door close limit is reached.

Function Code	Parameter Name	Setting Range	Default	Min. Unit
F4-14	Door close hindered working method	0, 1	1	1

- 0: Immediate stop upon door close hindered

If there is any door close command after or within 10s, door close is executed. If the running command is cancelled, door close is executed immediately.

- 1: Door re-open upon door close hindered

The controller does not respond to the external door open/close commands during the door re-open.

The door close hindered situation has the following two causes:

- The light curtain/safety edge signal is valid during the process of door close.
- The output torque is greater than the door close hindered torque during the process of door close.

Function Code	Parameter Name	Setting Range	Default	Min. Unit
F4-15	Door close hindered judging time	0–9999 ms	500 ms	1 ms

It is used to set the filter time when the door close is hindered. If it is set to 0, the door close hindered is not detected.

Function Code	Parameter Name	Setting Range	Default	Min. Unit
F4-16	Door close high speed setting at fire emergency	5.00 to F1-04	10.00Hz	0.01Hz

It is used to set the high-speed running speed at door close when the fire emergency input function is valid.

Function	Parameter Name	Setting Range	Default	Min. Unit
----------	----------------	---------------	---------	-----------

Code				
F4-17	Door close hindered high speed setting	F4-18 to F1-04	12.00 Hz	0.01 Hz
F4-18	Door close hindered low speed setting	0.00 Hz to F1-04	2.00 Hz	0.01 Hz
F4-19	High-speed torque setting	0.00%–150.0%	100.0%	0.1%
F4-20	Low-speed torque setting	0.00%–150.0%	100.0%	0.1%

These four parameters are used to judge how to handle door close hindered.

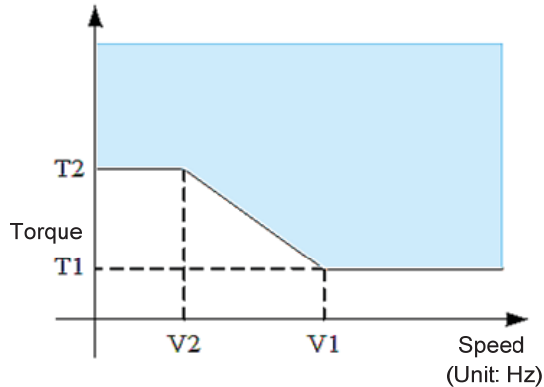

In the figure, V1 is F4-17, V2 is F4-18, T1 is F4-19 and T2 is F4-20. You have to set $F4-17 \geq F4-18$ and $F4-19 \leq F4-20$.

- If the door close running frequency is greater than V1, the door close hindered judging torque is T1.
- If the door close running frequency is smaller than V2, the door close hindered judging torque is T2.

If the door close running frequency is greater than V2 but smaller than V1, the door close hindered judging torque is defined by the oblique line in the figure.

Group F5 Door Open/Close Auxiliary Parameters

Function Code	Parameter Name	Setting Range	Default	Min. Unit
F5-00	Abnormality deceleration time	0.1–5.0s	0.3s	0.1s

It is used to set the time that it takes the system to decelerate from the door close speed to 0 when door close is hindered. Set this parameter to the minimum value as possible when ensuring that over-current does not occur during acceleration.

Function Code	Parameter Name	Setting Range	Default	Min. Unit
F5-01	Door open time limit	0–9999s	30.0s	1s

It is used to limit the door open time. If the controller does not receive the door open limit signal (pulse loss occurs in distance control mode) within the time, the controller performs door open overtime protection (Er28).

This parameter is invalid when it is set to 0.

Function Code	Parameter Name	Setting Range	Default	Min. Unit
F5-02	Door close time limit	0–9999s	0s	1s

It is used to limit the door close time. If the controller does not receive the door close limit signal within the time, the controller determines that door close is hindered, and performs door re-open or zero speed holding based on the setting of F4-14.

This parameter is invalid when it is set to 0.

Function Code	Parameter Name	Setting Range	Default	Min. Unit
F5-03	Low-speed running time limit	0-9999s	0s	1s

It is used to set the maximum running time of low-speed door open and close when the low-speed running signal is enabled. Set this parameter based on the actual situation. The value must be equal to or greater than the sum of the door open and door close time setting (parameter group of door open and close running curve); otherwise, Er26 is reported, indicating that the parameter setting is incorrect. The correct setting implements protection of the door machine in low-speed running state in the case of abnormalities.

The normal running time does not exceed the setting of this parameter. When the door open limit switch and door close limit switch fail, and an abnormality occurs (for example, the controller cannot determine whether door open/close reaches the limit switch), the running time exceeds the setting. In this case, Er30 is reported, indicating a door open/close operation error in low-speed running.

This parameter is invalid when it is set to 0.

Function Code	Parameter Name	Setting Range	Default	Min. Unit
F5-04	Delay of external door open command	0-9999s	60s	1s

It is used to set the torque holding time upon door open limit, that is, the holding time of the door open running state after the door open limit signal is valid but the door open command from the terminal becomes invalid.

If the actual holding time exceeds the value of this parameter, the controller stops. If the door open command is cancelled when door open limit is not reached, the controller stops immediately. At this moment, the delay function is invalid.

When it is set to 9999s, the delay of external door open command remains valid.

Function Code	Parameter Name	Setting Range	Default	Min. Unit
F5-05	Delay of external door close command	0-9999s	60s	1s

It is used to set the torque holding time upon door close limit, that is, the holding time of the door close running state after the door close limit signal is valid but the door close command from the terminal becomes invalid.

If the actual holding time exceeds the value of this parameter, the controller stops. If the door close command is cancelled when door close limit is not reached, the controller stops immediately. At this moment, the delay function is invalid.

When it is set to 9999s, the delay of external door close command remains valid.

Function Code	Parameter Name	Setting Range	Default	Min. Unit
F5-06	Door open curve selection	0, 1	1	1

It is used to set the running curve of the door machine during door open.

- 0: Linear acceleration/deceleration
- 1: S curve acceleration/deceleration

Function Code	Parameter Name	Setting Range	Default	Min. Unit
F5-11	Door close curve selection	0, 1	1	1

It is used to set the running curve of the door machine during door close.

- 0: Linear acceleration/deceleration
- 1: S curve acceleration/deceleration

Function Code	Parameter Name	Setting Range	Default	Min. Unit
F5-07	Start segment time of the door open acceleration S curve	10.0%–50.0% (acceleration/deceleration time, start segment + rising segment \leq 90%)	20.0%	0.1%
F5-08	Rising segment time of the door open acceleration S curve	10.0%–80.0% (acceleration/deceleration time, start segment + rising segment \leq 90%)	60.0%	0.1%
F5-09	Start segment time of the door open deceleration S curve	10.0%–50.0% (acceleration/deceleration time, start segment + falling segment \leq 90%)	20.0%	0.1%
F5-10	Falling segment time of the door open deceleration S curve	10.0%–80.0% (acceleration/deceleration time, start segment + falling segment \leq 90%)	60.0%	0.1%
F5-12	Start segment time of the door close acceleration S curve	10.0%–50.0% (acceleration/deceleration time, start segment + rising segment \leq 90%)	20.0%	0.1%
F5-13	Rising segment time of the door close acceleration S curve	10.0%–80.0% (acceleration/deceleration time, start segment + rising segment \leq 90%)	60.0%	0.1%
F5-14	Start segment time of the door close deceleration S curve	10.0%–50.0% (acceleration/deceleration time, start segment + falling segment \leq 90%)	20.0%	0.1%
F5-15	Falling segment time of the door close deceleration S curve	10.0%–80.0% (acceleration/deceleration time, start segment + falling segment \leq 90%)	60.0%	0.1%

These eight parameters are used to define the S curve features of each segment speed during running of the controller.

Each curve that combines the acceleration segment and deceleration segment is symmetric. Take acceleration of S curve 1 in the following figure as an example.

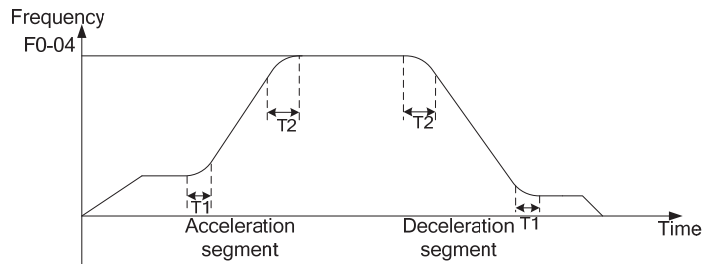

T1 stands for F5-07, during which the slope of the output frequency change (that is, speed change rate) increases gradually. T2 stands for F5-08, during which the slope of the output frequency change reduces gradually to low-speed frequency. Between T1 and T2, the slope of the output frequency change keeps unchanged.

Function Code	Parameter Name	Setting Range	Default	Min. Unit
F5-16	Speed deviation setting	0%–80%	50%	0%
F5-17	Time for determining speed deviation too large	0–5000 ms	400 ms	1 ms

The speed deviation detection function of the NICE900 is effective only in the FVC mode. The controller determines whether the deviation between the current running frequency and the set frequency is too large based on the value of F5-16. If the deviation remains too large for more than the time set in F5-17, the controller reports Er32 and performs protection for too large speed deviation.

When F5-16 is set to 0, the controller does not detect speed deviation.

Function Code	Parameter Name	Setting Range	Default	Min. Unit
F5-18	Door close steady speed delay	0–9999 ms	400 ms	1 ms

It is used to set the steady speed delay at door close. The controller determines whether door close is hindered only after the steady speed delay in F5-18.

Group F6: Distance Control Parameters

Function Code	Parameter Name	Setting Range	Default	Min. Unit
F6-00	Door width tuning function selection	0, 1	0	1

It is used to enable or disable the door width tuning function.

- 1: Enable door width tuning function
- 0: Disable door width tuning function

When F0-02 is set to 2 and F6-00 is set to 1, the door width tuning function is enabled. After you press the door open key or door close key, door width tuning is started. The door machine runs with the close-open-close logic. Upon door open limit and locked-rotor, the door width is stored. For details on the operation, see Chapter 7.

Function Code	Parameter Name	Setting Range	Default	Min. Unit
F6-01	Door width tuning speed	0 to F0-02 (max. frequency)	3.00 Hz	0.01 Hz

It is used to set the running frequency when the door machine performs door width tuning.

Function Code	Parameter Name	Setting Range	Default	Min. Unit
F6-02	Low bit of door width pulse	0–9999	0	1
F6-03	High bit of door width pulse	0–9999	0	1

The door width is calculated using the formula: Door width = F6-03 x 10000 + F6-02. The obtained door width pulses can be modified on the operation panel.

Function Code	Parameter Name	Setting Range	Default	Min. Unit
F6-04	Low-speed running distance of door open start in distance control	0.0%–30.0%	10.0%	0.1%

It records the number of pulses in real time during door open in distance control. When the number of pulses is equal to or greater than the value of door width multiplied by F6-04, the door machine switches over from door open startup low speed (F3-00) to door open high speed (F3-03)

Function Code	Parameter Name	Setting Range	Default	Min. Unit
F6-05	Door open deceleration point in distance control	60.0%–90.0%	70.0%	0.1%

It records the number of pulses in real time during door open in distance control. When the number of pulses is equal to or greater than the value of door width multiplied by F6-05, the door machine switches over from door open startup low speed (F3-03) to door open ending low speed (F3-05).

Function Code	Parameter Name	Setting Range	Default	Min. Unit
F6-06	Door open limit point in distance control	80.0%–99.0%	96.0%	0.1%

It records the number of pulses in real time during door open in distance control. When the number of pulses is equal to or greater than the value of door width multiplied by F6-06, the door machine performs related processing of door open limit.

Function Code	Parameter Name	Setting Range	Default	Min. Unit
F6-07	Low-speed running distance of door close start in distance control	0.0%–30.0%	10.0%	0.1%

It records the number of pulses in real time during door close in distance control. When the number of pulses is equal to or less than value of door width multiplied by (100% - F6-07), the door machine switches over from door open startup low speed (F3-00) to door open high speed (F3-03).

Function Code	Parameter Name	Setting Range	Default	Min. Unit
F6-08	Door close deceleration point in distance control	60.0%–90.0%	70.0%	0.1%

It records the number of pulses in real time during door close in distance control. When the number of pulses is equal to or less than the value of door width multiplied by (100% - F6-08), the door machine switches over from door open startup low speed (F3-03) to door open ending low speed (F3-05).

Function Code	Parameter Name	Setting Range	Default	Min. Unit
F6-09	Door close limit point in distance control	80.0%–99.0%	96.0%	0.1%

It records the number of pulses in real time during door close in distance control. When the number of pulses is equal to or less than the value of door width multiplied by (100% - F6-09), the door machine performs related processing of door close limit.

Function Code	Parameter Name	Setting Range	Default	Min. Unit
F6-10	Output torque display	0.0%–180.0%	0.0%	0.1%

It facilitates the torque setting for door width tuning or initial running (F6-14) at door width tuning for asynchronous motor. After the door width tuning is complete and the rotor is locked, ensure that F6-14 is slightly smaller than F6-10.

Function Code	Parameter Name	Setting Range	Default	Min. Unit
F6-11	Low bit of the door open limit switch's position	0–9999	0	1
F6-12	High bit of the door open limit switch's position	0–9999	0	1
F6-13	Position of the door close limit switch	0–9999	0	1

The three parameters are used to record the positions of the limit switches obtained during door width tuning. During normal running, when the door open limit switch is valid, the door position is restored to: $F6-12 \times 10000 + F6-11$. When the door close limit switch is valid, the door position is restored to the setting of F6-13.

Function Code	Parameter Name	Setting Range	Default	Min. Unit
F6-14	Torque setting for door width tuning or initial running	0.0%–150.0%	80.0%	0.1%

It is used to set the torque upper limit during door width tuning and first power-on running. This parameter is valid only in distance control. For details, see Chapter 7.

Function Code	Parameter Name	Setting Range	Default	Min. Unit
F6-15	Low bit of the pulse of door open deceleration point	0–9999	0	1
F6-16	High bit of the pulse of door open deceleration point	0–9999	0	1
F6-17	Low bit of the pulse of door close deceleration point	0–9999	0	1
F6-18	High bit of the pulse of door close deceleration point	0–9999	0	1

The four parameters are used to set the positions of the deceleration points.

The deceleration point is set based on the number of pulses rather than a percentage of the door width.

Position of the door open deceleration point = $F6-16 \times 10000 + F6-15$

Position of the door close deceleration point = F6-18 x 10000 + F6-17

Function Code	Parameter Name	Setting Range	Default	Min. Unit
F6-19	Pulse at door open limit output	0.0%–99.99%	0.0%	0.1%

It is valid only in distance control.

When the door width position is larger than F6-19, the door open limit signal is output. At this moment, even if the output torque is larger than F3-07, the door position is not restored to 100%. The door position is restored to 100% only when the door position is larger than F6-06 and the output torque is larger than F3-07.

When F6-19 is set to 0, the controller determines whether to output the door open limit signal based on the value of F6-06.

Function Code	Parameter Name	Setting Range	Default	Min. Unit
F6-20	Pulse at door close limit output	0.0%–99.99%	0.0%	0.1%

It is valid only in distance control.

When the door position is larger than F6-20, the door close limit signal is output, and the door vane is retracted. At this moment, even if the output torque is larger than F4-11, the door position is not restored to 100%. The door position is restored to 100% only when the door position is larger than F6-09 and the output torque is larger than F4-11.

When F6-20 is set to 0, the controller determines whether to output the door close limit signal based on the value of F6-09.

Function Code	Parameter Name	Setting Range	Default	Min. Unit
F6-21	Door position feedback pulse	0.0%–99.99%	33.0%	0.1%

It is valid only in distance control. When the door position is larger than F6-21, the door position feedback signal is output. It is used with F9-12 (door position feedback signal output).

Group F7: Demonstration Function Parameters

Function Code	Parameter Name	Setting Range	Default	Min. Unit
F7-00	Door open limit holding time in demonstration mode	0.5–999.9s	2.0s	0.1s

It is used to set the time from torque holding upon door open limit to reverse door close in demonstration mode. Set this parameter based on actual demonstration requirements.

Function Code	Parameter Name	Setting Range	Default	Min. Unit
F7-01	Door close limit holding time in demonstration mode	0.5–999.9s	2.0s	0.1s

It is used to set the time from torque holding upon door close limit to forward door open in demonstration mode. Set this parameter based on actual demonstration requirements.

Function Code	Parameter Name	Setting Range	Default	Min. Unit
F7-02	Times record of door open and	0–9999	0	1

	close in demonstration mode			
--	-----------------------------	--	--	--

It is used to record the times of door open and close. The parameter value is stored automatically at power failure. Upon door running limit after power-on again, the value is calculated by adding 1 for each door open/close to the original value.

The demonstration mode is an automatically cyclic running process. After you press the door open/close key, demonstration running is started. Then the door machine closes the door at a low speed, and performs door open running based on the running curve upon door close limit. The door machine starts timing upon door open limit, and automatically performs reverse door close running after the time reaches the value set in F7-00. The door machine starts timing upon door close limit, and performs reverse door open after the time reaches the value set in F7-01.

This process is repeated until you press the STOP/RES key to stop the controller. Then the demonstration process ends. Demonstration running can be performed in speed control or distance control mode. It applies to demonstration and aging test.

Function Code	Parameter Name	Setting Range	Default	Min. Unit
F7-03	Times setting of door open and close in demonstration mode	0-9999	0	1

It is used to set the times of door open and close in demonstration mode. When the times of actual door open and close in demonstration mode is equal to or greater than F7-03, demonstration running ends automatically. When F7-03 is set to 0, this function is invalid, and demonstration running does not end automatically.

Group F8: Auxiliary Parameters

Function Code	Parameter Name	Setting Range	Default	Min. Unit
F8-00	Software version	0.00-99.99	1.00	0.01

It is used to indicate the current software version of the controller to facilitate maintenance by the vendor.

Function Code	Parameter Name	Setting Range	Default	Min. Unit
F8-01	Module temperature	0-100°C	0°C	1°C

It is used to record the temperature of the lower module in the controller.

Function Code	Parameter Name	Setting Range	Default	Min. Unit
F8-02	Automatic fault reset times	0-100	0	1

The controller stops running after a fault occurs, and automatically resets and continues running after a 2s reset interval. When it is set to 0, the automatic reset function is not disabled, and you can only perform manual reset. If no fault occurs or manual reset is performed within an hour, the controller automatically clears the reset times.

Note

The controller does not automatically reset in the case of faults Er19 (motor tuning fault), Er 26 (prompt of incorrect parameter setting), and Er 27 (door width tuning fault).

Function Code	Parameter Name	Setting Range	Default	Min. Unit
F8-03	Brake use ratio	0–100%	100%	1%

It is valid for the controller with a built-in braking unit and used to adjust the braking effect of the brake unit.

Function Code	Parameter Name	Setting Range	Default	Min. Unit
F8-04	Accumulative operation time	0–9999	0	1

It is used to record the actual accumulative power-on operation time (hour) of the controller. After the value exceeds the maximum value 9999 hours, the controller starts a new round of counting.

Function Code	Parameter Name	Setting Range	Default	Min. Unit
F8-06	Accumulative running time	0–9999	0	1

It is used to record the accumulative running time (hour). After the value exceeds the maximum value 9999 hours, the controller starts a new round of counting.

Function Code	Parameter Name	Setting Range	Default	Min. Unit
F8-10	Auxiliary function selection	0–9999	0	1

It is used to select the required function.

Bit	Function	Default
BIT0	1: Trigger door open/close command 0: Non-trigger door open/close command	1
BIT1	1: Not reset pulses upon reaching the initial running torque 0: Reset pulses upon reaching the initial running torque	1
BIT2	1: Learn positions of limit switches during door width tuning. Reset the pulse signal when limit switches are valid 0: Not learn positions of limit switches	0
BIT3	In the SVC mode (F0-00 = 0) with distance control (F0-01= 1): 1: Determine whether door width tuning or initial running is successful and whether door close is hindered based on the torque 0: Determine that door width tuning or initial running is successful or that door close is hindered if there is no pulse signal within certain time (2s)	0
BIT4	1: Door close preferred 0: Door open preferred	0
BIT5	In door machine terminal control mode (F0-02 =1): 1: The controller runs properly when you press STOP during running. 0: The controller suspends and displays STP when you press STOP during running, and restores normal running when you press STOP again.	0
BIT6	Hindering mode: 1: Detect hindering torque based on F4-13 0: Detect hindering separately for high speed running and low speed	0

	running	
BIT7	Demonstration running: 1: Start demonstration running automatically upon power-on 0: Start demonstration running manually upon power-on	0
BIT8	Current cancelling: 0: Cancel current when the command is cancelled 1: Stop immediately when the command is cancelled	0

Function Code	Parameter Name	Setting Range	Default	Min. Unit
F8-11	Fault function selection	0–9999	12	1

It is used to change the value to satisfy the desired functions.

Bit	Function	Default
BIT1	1: Enable magnetic pole position auto detection function 0: Disable magnetic pole position auto detection function	0

Because there is signal Z interference in some applications, the deviation appears when the door machine judges the magnetic pole position.

The magnetic pole position identification will be performed automatically at next startup, resulting in a choked sound at startup of door open/close. You can disable the magnetic pole position auto detection function through this parameter.

Function Code	Parameter Name	Setting Range	Default	Min. Unit
F8-12	Drive function selection	0–9999	0	1

The setting of BIT0 is as follows:

- 0: Overall 7-segment modulation (reduce the noise)
- 1: 7-segment/5-segment automatic switchover during running

Function Code	Parameter Name	Setting Range	Default	Min. Unit
F8-14	Overload coefficient	0–10.00	1.00	0.01

It is used to perform overload protection on the motor.

Function Code	Parameter Name	Setting Range	Default	Min. Unit
F8-16	Number of door machines	1, 2	1	1

When the communication protection function is enabled, set it to 1 for the front door and to 2 for the back door.

Group F9: Input and Output Function Parameters

Function Code	Parameter Name	Setting Range	Default	Min. Unit
F9-00	Terminal filter time	0–100 ms	20 ms	1 ms

It is used to set the terminal sensitivity. If misoperation may occur due to interference to the DIs, increase the value of this parameter to increase the anti-interference capability. This, however, reduces sensitivity of the DIs.

Function Code	Parameter Name	Setting Range	Default	Min. Unit
F9-01 to F9-08	DI function selection	0–116 (cannot be selected repeatedly)	See Chapter 5	1

- 0: No function
- 1: Door open command sent by the system
- 2: Door close command sent by the system
- 3: External reset terminal signal
- 4: Forbid terminal input during door open
When this signal is valid, the controller does not respond to external door open commands.
- 5: Forbid terminal input during torque holding
During torque holding upon door open/close limit, this signal is valid and zero torque holding is performed.
- 6: Low-speed door close command
When this signal is valid, the controller closes the door at a low-speed frequency (F0-06).
- 7: Fire-emergency input
When this signal is valid, the system closes the door in the fire-emergency high speed (F4-19).
- 8 to 109: Reserved
- 10/110: NO/NC input of light curtain signal
If this signal is valid during door close, protection upon door close hindering is performed. When the door is re-opened, the system does not respond to the door close command. If the door reaches the door close limit position, this signal is invalid.
- 11/111: NO/NC input of safety edge signal
If this signal is valid during door close, protection upon door close hindering is performed. When the door is re-opened, the system does not respond to the door close command. If the door reaches the door close limit position, this signal is invalid.
- 12/112: NO/NC input of door open limit signal
When this signal is valid, the controller performs door open limit processing.
- 13/113: NO/NC input of door close limit signal
When this signal is valid, the controller performs door close limit processing.
- 14/114: NO/NC input of door open deceleration signal
During door open in speed control, the system switches to low-speed running of the end segment after this signal becomes valid.
- 15/115: NO/NC input of door close deceleration signal

During door close in speed control, the system switches to low-speed running of the end segment after this signal becomes valid.

- 16/116: NO/NC input of door lock signal

The controller receives information related to door lock.

Function Code	Parameter Name	Setting Range	Default	Min. Unit
F9-09	Relay output selection (TA1/TB1/TC1)	0–12	2	1
F9-10	Relay output selection (TA2/TB2/TC2)	0–12	5	1
F9-11	Relay output selection (TA3/TB3/TC3)	0–12	1	1

- 0: No function

- 1: Door open limit signal output 0

During door open, the controller outputs this signal after the controller receives the door open limit signal or the counting pulses reach the value at door open limit.

- 2: Door close limit signal output 0

During door close, the controller outputs this signal after the controller receives the door close limit signal or the counting pulses reach the value at door close limit.

- 3: Door open limit signal output 1

During door open, the controller outputs this signal after the controller receives the door open limit signal or the counting pulses reach the value at door open limit, and the locked- rotor torque reaches the value set in F3-07.

- 4: Door close limit signal output 1

During door close, the controller outputs this signal after the controller receives the door close limit signal or the counting pulses reach the value at door close limit, and the ratio of the locked-rotor torque to the rated torque reaches the value set in F4-11.

- 5: Fault signal output 1 (Er26 is only a prompt rather than a fault.)

- 6: Reserved

- 7: Door open limit signal output 2

During door open, the controller outputs this signal after the controller receives the door open limit signal or the counting pulses reach the value at door open limit, the door lock signal becomes invalid, and the ratio of the locked-rotor torque to the rated torque reaches the value set in F3-07.

- 8: Door close limit signal output 2

During door close, the controller outputs this signal after the controller receives the door close limit signal or the counting pulses reach the value at door close limit, the door lock signal becomes invalid, and the ratio of the locked-rotor torque to the rated torque reaches the value set in F4-11.

- 9: Door lock signal output

It is simultaneous with the door lock signal input.

- 10: Door re-open signal output

- 11: Hindering signal output

This signal is output when door close is hindered.

- 12: Door position feedback output

When the door width position is greater than F6-21, the door position feedback signal is output.

Group FA: Display and Fault Parameters

Function Code	Parameter Name	Setting Range	Default	Min. Unit
FA-00	Selection of running parameters displayed on LED	1–511	319	1

It is used to control the display of nine status parameters. Whether a parameter is displayed is controlled by a binary bit. "1" indicates display, and "0" indicates not display. You can switch over the parameter display via the shift key in the running state of the control system.

Function Code	Parameter Name	Setting Range	Default	Min. Unit
FA-01	Selection of stop parameters displayed on LED	1–63	39	1

It is used to control the display of six status parameters. Whether a parameter is displayed is controlled by a binary bit. "1" indicates display, and "0" indicates not display. You can switch over the parameter display via the shift key in the stop state of the control system

Function Code	Parameter Name	Setting Range	Default	Min. Unit
FA-02	1st fault type	0–30	0	1
FA-03	1st fault prompt	0–9	0	1
FA-04	2nd fault type	0–30	0	1
FA-05	2nd fault prompt	0–9	0	1
FA-06	3rd fault type	0–30	0	1
FA-07	3rd fault prompt	0–9	0	1
FA-08	4th fault type	0–30	0	1
FA-09	4th fault prompt	0–9	0	1
FA-10	5th fault type	0–30	0	1
FA-11	5th fault prompt	0–9	0	1
FA-12	Bus voltage at occurrence of the latest fault	0–999.9 V	0 V	0.1 V
FA-13	Output current at occurrence of the latest fault	0–99.99 A	0.00 A	0.01 A
FA-14	Running frequency at occurrence of the latest fault	0–99.00 Hz	0.00 Hz	0.01 Hz
FA-15	Output torque at occurrence of the latest fault	0.0–180.0% (percentage of output torque to rated torque)	0.0%	0.1%

FA-16	Input terminal status at occurrence of the latest fault	0–1023	0	1
FA-17	Output terminal status at occurrence of the latest fault	0–15	0	1

These parameters record the latest five faults and detailed information about the latest fault. For details, see Chapter 8. Note that Er26 is only a message prompting that the parameter setting is incorrect, and is not stored in the fault record.

Function Code	Parameter Name	Setting Range	Default	Min. Unit
FA-18	Terminal status query	*	*	*

It is used to indicate the input and output display of the corresponding terminal. When the terminal is input valid or output valid, a certain segment of the corresponding nixie tube is on. The nixie tubes from left to right are LED1, LED2, LED3, and LED4.

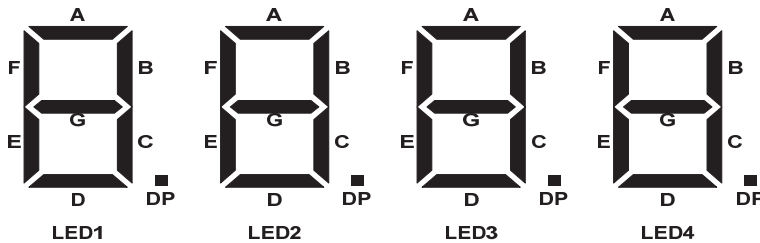

The meaning of each nixie tube segment is defined as follows:

Segment (LED1)	Meaning of ON	LED2	LED3	Segment (LED4)	Meaning of ON
A	DI1 input valid	Door open running procedure (for viewing and commissioning)	Door close running procedure (for viewing and commissioning)	A	TA1 and TC1 ON
B	DI2 input valid			B	TA2 and TC2 ON
C	DI3 input valid			C	TA3 and TC3 ON
D	DI4 input valid			D	Reserved
E	DI5 input valid			E	
F	DI6 input valid			F	
G	DI7 input valid			G	
DP	DI8 input valid			DP	Blink, indicating that RS485 communication is normal

Function Code	Parameter Name	Setting Range	Default	Min. Unit
FA-19	Function input status query	*	*	*

It is used to indicate input display of the corresponding function. When the function is input valid, a certain segment of the corresponding nixie tube is on. The nixie tubes from left to right are LED1, LED2, LED3, and LED4.

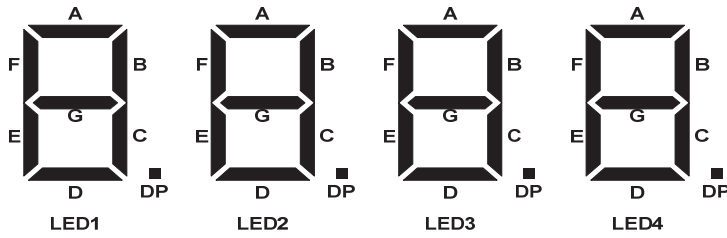

The meaning of each nixie tube segment is defined as follows:

Segment (LED1)	Meaning of ON	Segment (LED2)	Meaning of ON	Segment (LED3 & LED4)	Meaning of ON
A	Door open command valid	A	Reserved	Reserved	Reserved
B	Door close command valid	B	Light curtain signal valid		
C	External reset valid	C	Safety edge signal valid		
D	Input forbidden valid at door open	D	Door open limit signal valid		
E	Input forbidden valid at torque holding	E	Door close limit signal valid		
F	Input valid at low-speed door open	F	Door open deceleration signal valid		
G	Fire-emergency input valid	G	Door close deceleration signal valid		
DP	Reserved	DP	Door lock signal valid		

Function Code	Parameter Name	Setting Range	Default	Min. Unit
FA-20	Function output status query	*	*	*

It is used to indicate whether output display of the corresponding function. When the function is output valid, a certain segment of the corresponding nixie tube is on. The nixie tubes from left to right are LED1, LED2, LED3, and LED4.

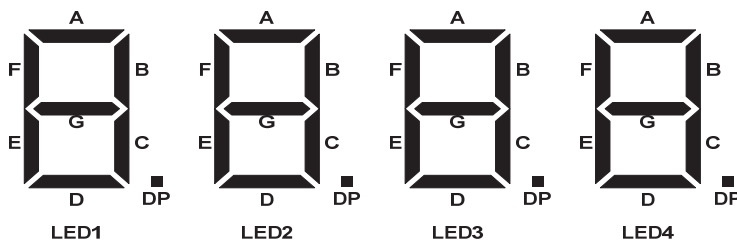

The meaning of each nixie tube segment is defined as follows:

Segment	Meaning of ON	Segment	Meaning of ON	Segment	Meaning
---------	---------------	---------	---------------	---------	---------

(LED1)		(LED2)		(LED3 & LED4)	of ON
A	Door open limit signal output 0	A	Door lock signal output	Reserved	Reserved
B	Door close limit signal output 0	B	Door re-open signal output		
C	Door open limit signal output 1	C	Hindering signal output		
D	Door close limit signal output 1	D	Reserved		
E	Fault signal output 1	E			
F	Reserved	F			
G	Door open limit signal output 2	G			
DP	Door close limit signal output 2	DP			

Function Code	Parameter Name	Setting Range	Default	Min. Unit
FA-21	Display control by switch	0–9999	0	1

Function Code	Parameter Name	Setting Range	Default	Min. Unit
FA-22	Display 1	0–9999	0	1
FA-23	Display 2	0–9999	0	1

It is used to set the actually displayed content of FA-22 and FA-23 for fault identification and commissioning onsite. The meanings of values are as follows:

Value	Displayed Content of FA-22	Displayed Content of FA-23		
1	Average speed within 1s (Hz)	Average value of speed fluctuation within 1s (Hz)		
2	Maximum speed within 1s (Hz)	Minimum speed within 1s (Hz)		
3	Slip frequency (Hz)	Actual feedback frequency (Hz)		
4	Excitation current component (A)	Torque current component (A)		
Other	Number of pulses received from the encoder within 1s (high bit)	Number of pulses received from the encoder within 1s (low bit)		
Function Code	Parameter Name	Setting Range	Default	Min. Unit
FA-24	Analog voltage display	0.00–10.1 V	0.00 V	0.01 V

It is used to display the sampled analog voltage in real time.

Function Code	Parameter Name	Setting Range	Default	Min. Unit
FA-25	Low bit of current door position	0–9999	0	1
FA-26	High bit of current door position	0–9999	0	1

The two parameters record the current door position.

Current door position = FA-26 x 10000 + FA-25

Function Code	Parameter Name	Setting Range	Default	Min. Unit
FA-27	Running status display	0–9999	0	1

It is used to query the status of the door machine, such as door open, door close, or running.

Function Code	Parameter Name	Setting Range	Default	Min. Unit
FA-28	Door direction judgment	*	*	*

It is used to detect the signal wiring of the encoder AB phase.

- If "OPEN" is displayed when you manually pull the door to the open direction, it indicates that the AB phase signal wiring is correct. Otherwise, the AB phase signal is abnormal.
- If "CLOSE" is displayed when you manually pull the door to the close direction, it indicates that the AB phase signal wiring is correct. Otherwise, the AB phase signal is abnormal.

Group FP: User Parameters

Function Code	Parameter Name	Setting Range	Default	Min. Unit
FP-00	User password	0–9999	0	1

The password protection function is enabled when you set this parameter to any non-zero number.

0000: When you set the parameter to this value, the original password is cleared, and the password protection function is disabled.

After a password is set and takes effect, enter the correct password when you want to set parameters. If the entered password is incorrect, you cannot query or modify parameters. Remember the password that you set. If you forget the password, contact the vendor.

Function Code	Parameter Name	Setting Range	Default	Min. Unit
FP-01	Parameter update	0–2	0	1

- 0: No function
- 1: Restore the default setting.
- 2: Clear fault records and time.

Function Code	Parameter Name	Setting Range	Default	Min. Unit
FP-02	Password for viewing parameters	0–9999	0	1

After it is set to a non-zero number, you can query and modify only certain function codes. After this parameter is set, "0000" is displayed when you enter the parameter setting state. You are allowed to modify this parameter and view parameters of all function codes only after entering the correct password.

0000: Clear the original password. All function codes can be viewed.

Chapter 7 Application and Commissioning

This chapter describes the basic procedure and setting of parameters when you use the NICE900 series controller to build the door machine application system. The applications in the speed control and distance control are introduced here.

7.1 Commissioning of the Door Machine Controller

7.1.1 Commissioning Flow Chart

After the peripheral circuit is available and mechanical installation is complete, you can follow the instructions described in this section to complete basic commissioning of the door machine controller. The commissioning flow chart is shown as below:

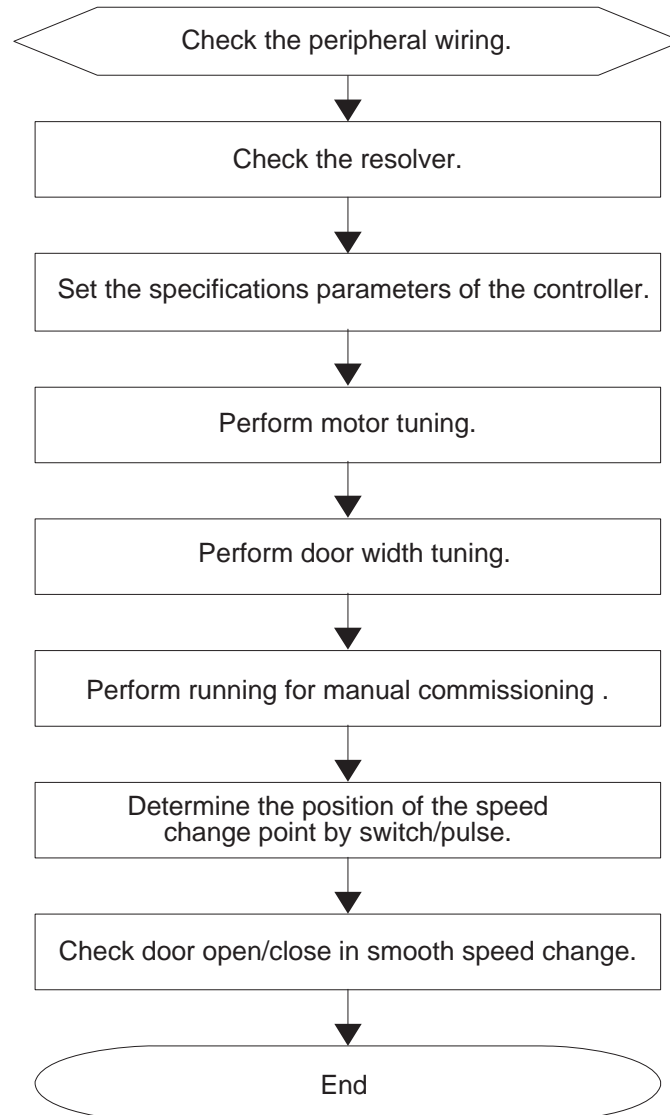

7.1.2 Checking the Peripheral Wiring

Before powering on the system, check peripheral wiring to guarantee component and personal safety.

1. Check that the wiring is correct according to the factory drawing.
2. Check that all switches act normally and reliably.
3. Check the interphase resistance of the main circuit and ensure that no ground short-circuit exists.
4. Check that the mechanical installation is complete to prevent equipment damage or personal injury.

7.1.3 Checking the Encoder

Pulse signals fed back by the encoder are critical to precise control of the system. You need to check the following items carefully before commissioning.

1. The encoder is stably installed with reliable wiring.
2. The encoder's signal lines and high-voltage circuit are arranged in different troughs to prevent interference.
3. It is better that the encoder is directly connected to the controller. If the cable is not long enough and cable extension is required, the extended part must also be shielded and welded to the original cable of the encoder using the soldering iron.
4. The shielding layer of the encoder is reliably grounded on the end connected to the controller.

7.1.4 Checking the Grounding

Check whether the following resistance is infinite. If the resistance is not large enough, check immediately.

1. Resistance between the L1/L2 terminal and the PE terminal
2. Resistance between the U/V/W terminal and the PE terminal
3. Resistance between the 24V/PGA/PGB/PGZ/COM terminal and the PE terminal

7.1.5 Checking the Signal Wiring

Check the signal wiring based on the indicator status.

Indicator	Meaning of Indicator ON in Stop State		Meaning of Indicator ON in Running State
	Speed Control	Distance Control (with Limit Switch)	
D1	DI1 signal valid	DI1 signal valid	External door close command
D2	DI2 signal valid	AB phase signal correct	Door close running
D3	DI3 signal valid	Z phase signal	Door open running
D4	DI4 signal valid	DI4 signal valid	External door open command

■ In Speed Control

Note

It is recommended that DI1 be connected to the door close limit switch, DI2 to the door close deceleration switch, DI3 to the door open deceleration switch, and DI4 to the door open limit switch.

You can check whether the signal wiring is correct based on the indicator status listed in the preceding table when pulling the door manually.

■ **In Distance Control**

Note

When there are limit switches, it is recommended that DI1 be connected to the door close limit switch and DI4 to the door open limit switch.

If the D2 indicator is on when you pull the door to the open direction, it indicates that the AB phase signal is normal. Otherwise, the AB phase signal is abnormal. In this case, exchange the AB phase signal lines. If the D2 indicator is steady off when you pull the door to the close direction, it indicates that the AB phase signal is normal.

During the process of manually pulling the door, the D3 indicator blinks once if a Z phase signal is received. If the D3 indicator is steady off, it indicates that the Z phase signal is abnormal.

■ **In Running State**

If the D1 indicator is on, it indicates that the external door close command is valid. If the D2 indicator is on, it indicates that the door machine is running for door close.

If the D3 indicator is on, it indicates that the external door open command is valid. If the D4 indicator is on, it indicates that the door machine is running for door open.

7.1.6 Application of the AC PMSM

The magnetic pole position of the AC permanent magnetic synchronous motor (PMSM) must be tuned before the first use. Otherwise, the motor cannot work properly. If the motor wiring, encoder, or encoder wiring is changed, re-tune the magnetic pole position.

Ensure that the motor wiring during tuning of the magnetic pole position is the same as the motor wiring during normal running. Guarantee safety because the motor is running during the motor tuning. The motor tuning flow chart is shown as below:

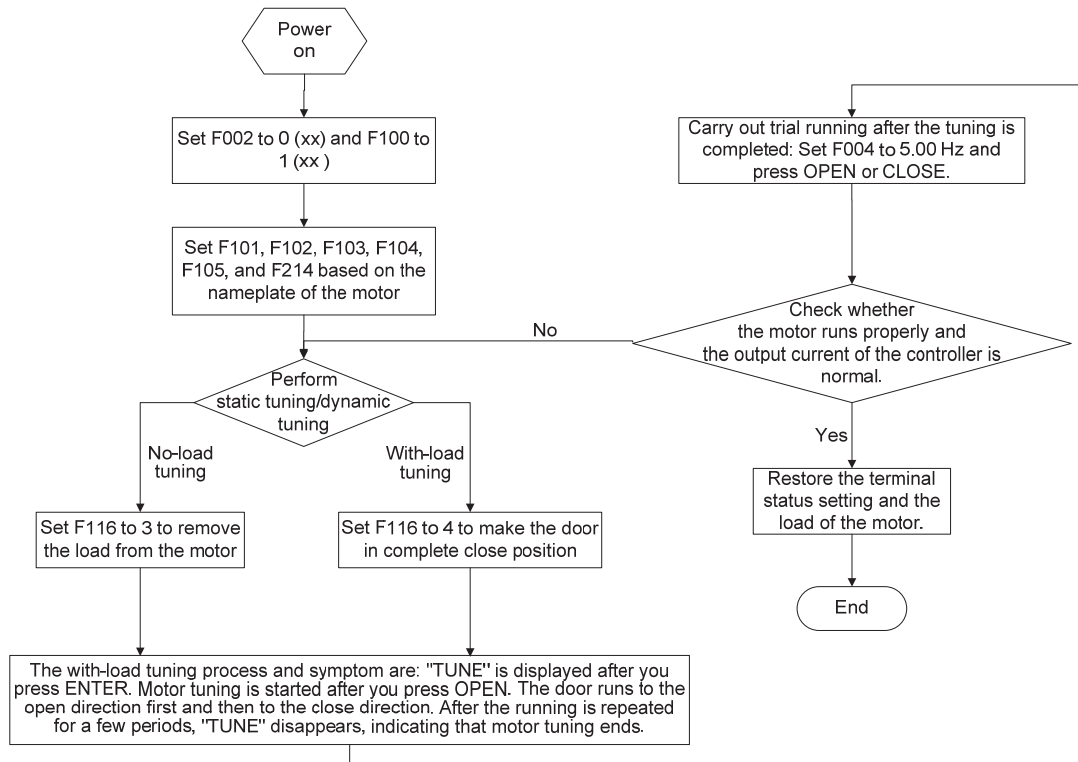

Note

Ensure that the encoder signals are normal before tuning. If the door runs to the close direction and locked-rotor occurs after tuning is started, it indicates that the running direction of the motor is abnormal. In this case, exchange the motor or encoder wiring.

Before starting tuning, correctly enter the motor parameters in Group F1 according to the nameplate, including rated power, rated voltage, rated frequency, rated speed, and rated current, and correctly set the PPR of the encoder (F2-14). Then, set F1-16 to 3 (No-load tuning for PMSM) or 4 (With-load tuning for PMSM) and press ENTER, and "TUNE" is displayed on the controller. After you press OPEN, the controller starts to perform parameter tuning. "TUNE" is displayed on the controller during the whole tuning process. When "TUNE" disappears, tuning ends.

During no-load tuning, the motor executes the forward rotation tuning command or reverse rotation tuning command, and runs toward the opposite direction after a certain time period. After several cycles, all parameters are calculated and un-load tuning is completed.

If Er20 occurs during no-load tuning, exchange any two phases of U, V, and W and perform tuning again.

During with-load tuning, enable the door to stay in complete closed state, and press OPEN to perform door open at 25% of the rated rotation speed; after the door runs for a certain distance, perform door close. After the door open and close operation is repeated for three times, all parameters are calculated and with-load tuning is completed.

If the motor does not run or the running direction is different from the door open/close

command during with-load tuning, it indicates that the motor wiring is incorrect. In this case, exchange any two phases of the motor and perform tuning again.

The encoder zero-point position of PMSM (F1-14) can be queried and modified. After position tuning, this parameter cannot be modified; otherwise, the controller cannot run properly. The value of this parameter obtained under with-load tuning has lower precision than that obtained under un-load tuning. If possible, perform un-load tuning.

If Er19 occurs during encoder position tuning, check whether the wiring of the encoder is correct.

7.1.7 Door Width Tuning

Ensure that the AB phase signal wiring of the encoder is correct before door width tuning for an asynchronous motor in distance control. The door changes the running direction automatically during door width tuning. Therefore, guarantee personal safety before performing the operation. Otherwise, personal injury may result.

Before performing door width tuning, ensure that there is no obstacle in the running direction of the door. If the door is hindered by an obstacle, the system determines that the door reaches the limit position, and the obtained door width is incorrect. The following figure shows the time sequence for door width tuning.

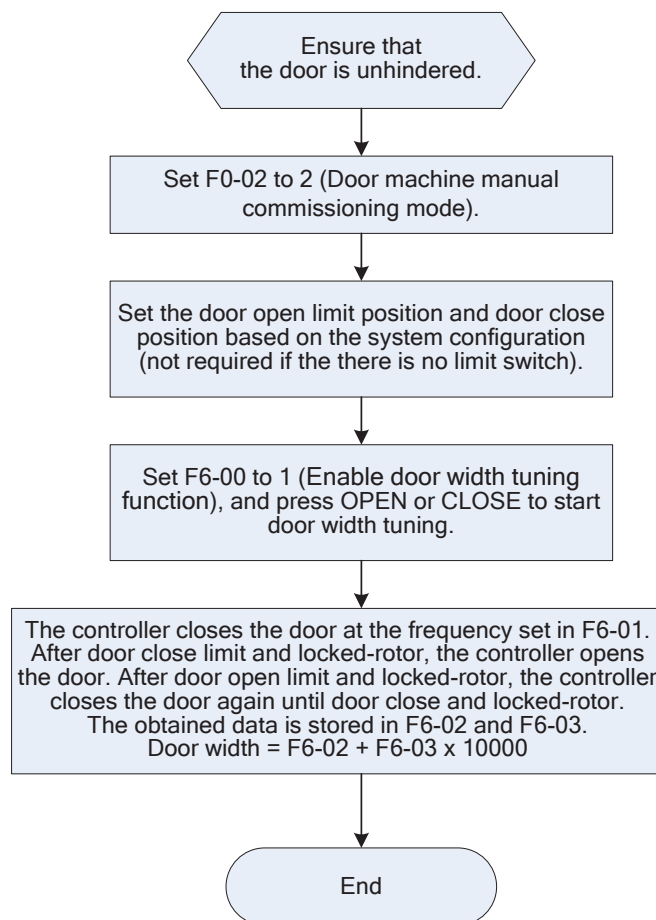

7.1.8 Trial Running

After the encoder position is identified and before you restore the load, perform trial running. It is recommended that you perform trial running in operation panel control.

Pay attention to the following points during trial running:

- 1) Check whether the running direction of the motor is consistent with the actual situation (door open or close state). If not, change the wiring from the door machine controller to the motor, and perform encoder position tuning again.
- 2) Check that the motor rotates smoothly without noise either in the forward direction or reverse direction. The motor has no load, and therefore the current of the controller is very small.

If the preceding two conditions are met, the controller records the positions of the motor and the encoder correctly in F1-14 (you can record the values for future use). Then, normal control on the motor can be performed. Considering the features of the PMSM and asynchronous motor, you can reduce the speed loop proportional gain 1 (F2-00) appropriately.

7.2 Typical Applications

7.2.1 In Speed Control

In speed control, deceleration is implemented by using the deceleration points and limit signals to judge door open/close limit. The Wiring of the typical system application in speed control is shown as below:

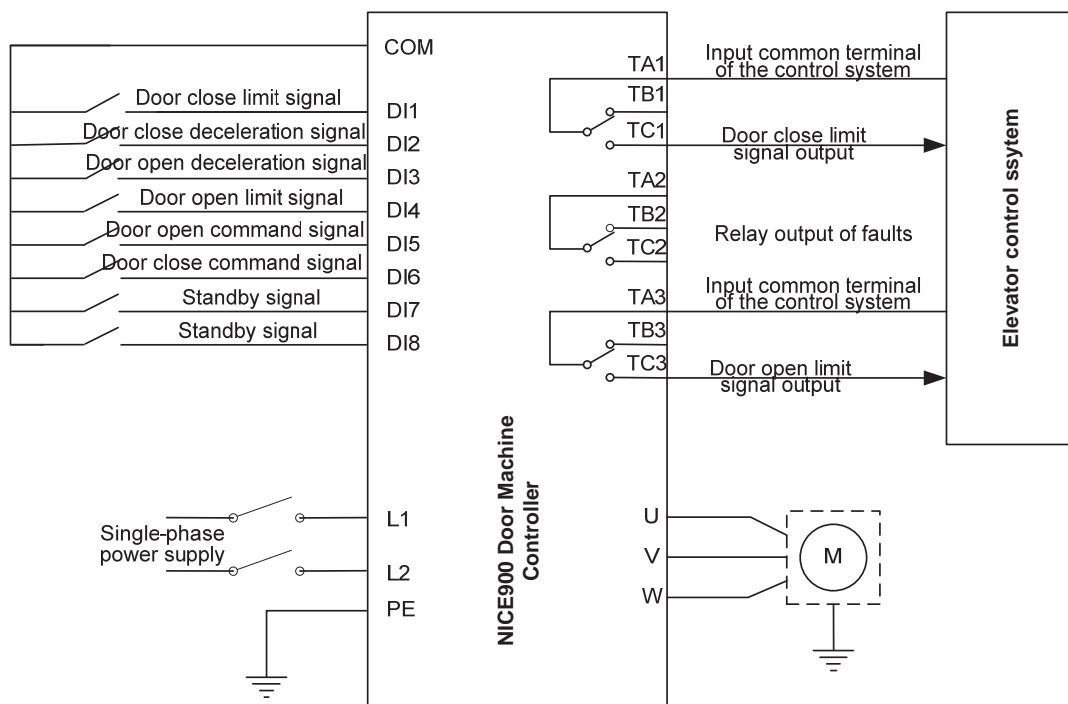

The running curve when the door open command is valid during door close in speed control is shown as below:

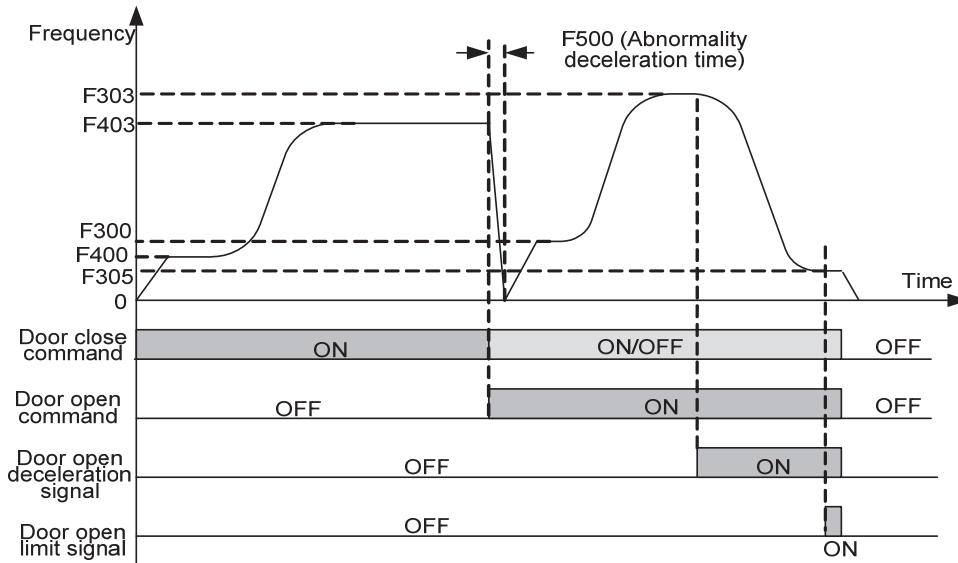

If the door is hindered during close, the controller decelerates to stop with "Abnormality deceleration time" set in F5-00. When the door is re-opened, the controller starts at a low-speed for door open, and runs at a high speed after the door open startup low speed running time in speed control set in F3-02. After the door open deceleration signal becomes valid, the controller runs in a low speed until door open limit and outputs the door open limit signal.

7.2.2 Distance Control Mode

■ Wiring of the Application with Pulse + Limit Switch

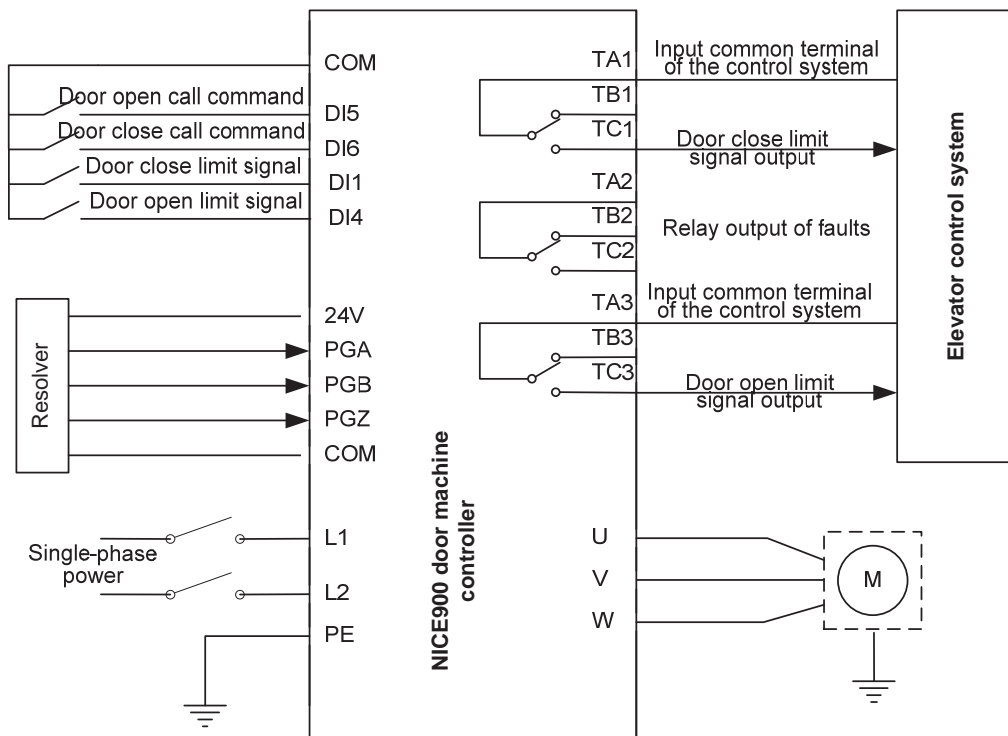

Note

In this mode, if the limit switches are valid, the output is the door open/close limit signal output 0 rather than the pulse.

■ **B. Wiring of the Application with Full Pulse**

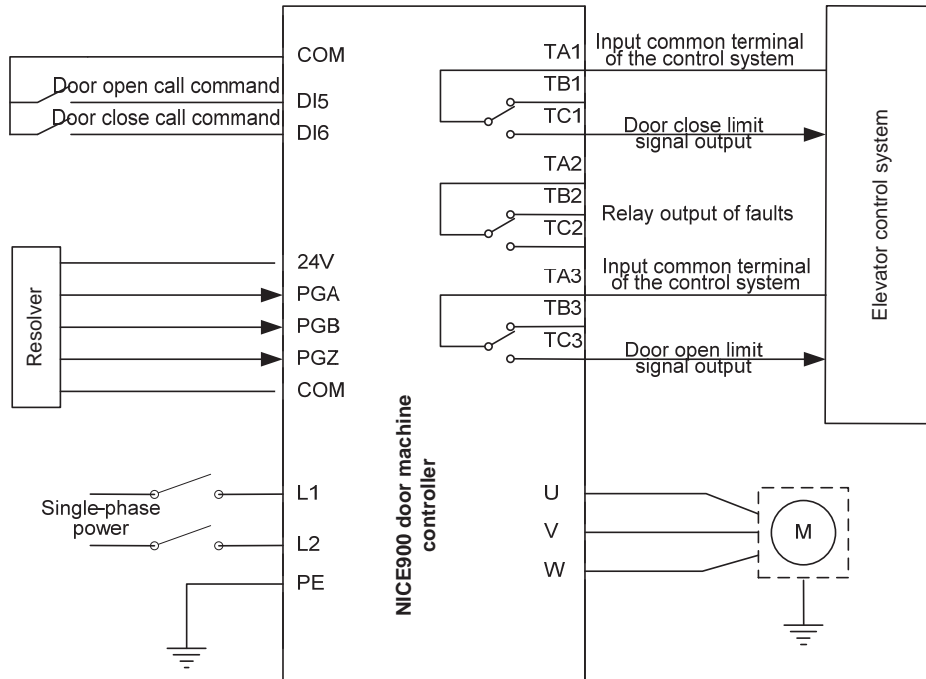

■ **C. Running Curve of Door Close Hindered**

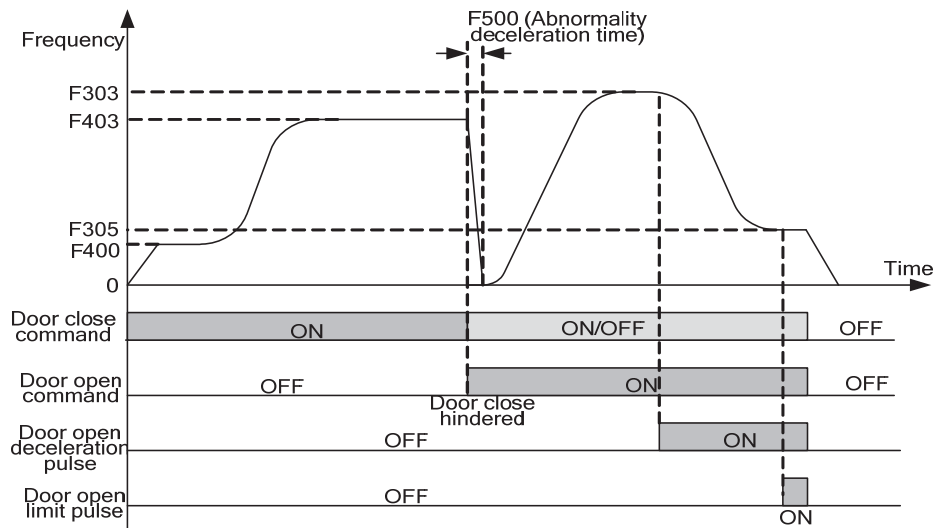

Chapter 8 Faults and Protective Functions

The controller provides almost 32 pieces of alarm information or protection functions. It monitors all types of input signals, running conditions and external feedback. If any abnormality occurs, the controller implements corresponding protection function and displays the error code.

If a fault occurs, the controller performs corresponding processing based on the error code. You can analyze the fault based on the information provided in the following table, find out the causes, and rectify the fault.

Error Code	Description	Cause	Troubleshooting	Remarks
Er02	Over-current during acceleration	<ol style="list-style-type: none"> 1. The main circuit is grounded or short-circuited on the output side. 2. An error occurs during motor tuning. 3. The load is too heavy. 	<ol style="list-style-type: none"> 1. Eliminate external problems such as wiring error. 2. Perform motor tuning again. 3. Reduce the burst load. 	
Er03	Over-current during deceleration	<ol style="list-style-type: none"> 1. The main circuit is grounded or short-circuited on the output side. 2. An error occurs during motor tuning. 3. The load is too heavy. 4. The deceleration curve is too steep. 	<ol style="list-style-type: none"> 1. Eliminate external problems such as wiring error. 2. Perform motor tuning. 3. Reduce the burst load. 4. Modify the parameters of the curve. 	
Er04	Over-current at constant speed	<ol style="list-style-type: none"> 1. The main circuit is grounded or short-circuited on the output side. 2. An error occurs during motor tuning. 3. The load is too heavy. 4. The resolver has strong interference. 	<ol style="list-style-type: none"> 1. Eliminate external problems such as wiring error. 2. Perform motor tuning. 3. Reduce the burst load. 4. Choose a proper resolver and uses a shielded resolver wire. 	
Er05	Over-voltage during acceleration	<ol style="list-style-type: none"> 1. The input voltage is too high. 2. The brake resistance is too large. 3. The acceleration curve is too steep. 	<ol style="list-style-type: none"> 1. Reduce the input voltage. 2. Choose a proper brake resistor. 3. Modify the parameters of the curve. 	
Er06	Over-voltage	<ol style="list-style-type: none"> 1. The input voltage is too 	<ol style="list-style-type: none"> 1. Reduce the input 	

Error Code	Description	Cause	Troubleshooting	Remarks
	during deceleration	high. 2. The brake resistance is too large. 3. The deceleration curve is too steep.	voltage. 2. Choose a proper brake resistor. 3. Modify the parameters of the curve.	
Er07	Overvoltage at constant speed	1. The input voltage is too high. 2. The brake resistance is too large.	1. Reduce the input voltage. 2. Choose a proper brake resistor.	
Er09	Under-voltage protection	1. The input power supply fails instantaneously 2. The input voltage is too low. 3. The control board is abnormal.	1. Eliminate external power supply problems. 2. Contact the agent or the vendor.	The controller resets automatically after the voltage becomes normal.
Er10	System overloaded	1. The guide rail of the elevator door is blocked by stuff. 2. The load is too heavy.	1. Check the guide rail of the elevator door. 2. Reduce the load.	
Er11	Motor overloaded	1. The guide rail of the elevator door is blocked by stuff. 2. The motor parameters are incorrect. 3. The load is too heavy.	1. Check the guide rail of the elevator door. 2. Check the motor parameters. 2. Reduce the load. 3. Increase the value of F8-14 (Overload coefficient) or F1-03 (Rated current).	
Er13	Phase loss at output side	1. The wiring of the main circuit is loose on the output side. 2. The motor is damaged.	1. Check the wiring. 2. Rectify faults of the motor.	The controller decelerates and stops.
Er14	Module overheat	1. The ambient temperature is too high. 2. The fan is damaged. 3. The air ventilation channel is blocked.	1. Reduce the ambient temperature. 2. Clear the air ventilation channel. 3. Replace the fan.	The controller decelerates and stops, and automatically resets after the temperature becomes

Error Code	Description	Cause	Troubleshooting	Remarks
				normal.
Er16	EEPROM fault	An EEPROM reading or writing abnormality occurs.	Contact the agent or vendor.	
Er18	Current detection fault	The control board is abnormal.	Contact the agent or vendor.	
Er19	Motor tuning overtime	<ol style="list-style-type: none"> The motor parameters are incorrectly set. The resolver for the PMSM is abnormal. 	<ol style="list-style-type: none"> Enter the motor parameters correctly. Check the lead wire of the motor. Check wiring of the resolver and ensure the PPR is set correctly. 	
Er20	Resolver fault	<ol style="list-style-type: none"> The resolver model is incorrect. The wiring of the resolver is incorrect. 	<ol style="list-style-type: none"> Use an ABZ phase resolver of open collector. Eliminate wiring problems. 	
Er21	Initial position detection fault	The motor parameters are incorrectly set.	Enter the motor parameters correctly.	
Er25	Overspeed fault	1. The door open/close high speed keeps 20% larger than the setting speed for 50 ms.	1. Check wiring of the resolver.	
Er26	Parameter setting incorrect	<ol style="list-style-type: none"> During door width tuning, F0-02 (Command source selection) is not set to 2 (Door machine manual commissioning mode), or F0-01 (Door open/close mode selection) is not set to 1 (Distance control). F0-00 (Control mode) is set to 0 (SVC). F0-00 is set to 0 (SVC) when the controller drives a PMSM. 	<ol style="list-style-type: none"> Set F0-02 to 2 or F0-01 to 1 during door width tuning. When F1-00 (Motor type selection) is set to 1 (PMSM), set F0-00 (Control mode) to 1 (FVC). 	It is only a prompt, and not recorded as a fault.
Er27	Bandwidth tuning fault	<ol style="list-style-type: none"> The door width obtained through door width tuning is smaller than 20 pulses. Distance control running is performed before door width tuning. 	<ol style="list-style-type: none"> Check wiring of the resolver and related parameters. Check the mechanical system of the door machine. Perform door width tuning before starting 	

Error Code	Description	Cause	Troubleshooting	Remarks
			distance control running.	
Er28	Door open overtime	1. The door open limit signal is abnormal or incorrectly set. 3. The wire to the pulse encoder is broken.	1. Check the door open limit signal. 2. Check wiring of the encoder.	The controller can reset automatically.
Er29	Door close overtime	1. The running direction of the motor is opposite to the door open direction. 2. The door close limit signal is abnormal or incorrectly set. 3. The wire to the pulse encoder is broken.	1. Change the wiring phase sequence of the motor or set F0-04 to 1. 2. Check the door close limit signal. 3. Check wiring of the encoder.	The controller can reset automatically.
Er30	Low-speed door close overtime	1. The door open/close limit signal is abnormal or incorrectly set. 2. The wire of the pulse encoder is broken.	1. Check the door close limit signal. 2. Check wiring of the encoder.	The controller can reset automatically.
Er31	Door open hindered protection	1. The guide rail of the elevator door is blocked by stuff. 2. The door open hindering parameters are incorrectly set.	1. Clear the stuff in the guide rail. 2. Set the upper limit of door open torque to a proper value. 3. Set F3-11 (Door open hindered judging time) to a proper value.	The controller can reset automatically.
Er32	Speed deviation protection	1. Acceleration or deceleration is too abrupt. 2. The tuned motor angle is incorrect, causing the elevator runaway.	1. Increase the acceleration or deceleration time. 2. Perform angle tuning again. 3. Change the value of F5-16 and F5-17.	

Chapter 9 Specifications of the ISMD1-5B0180A-I20X PMSM

9.1 Motor Parameters and Specifications

9.1.1 Motor Parameters

ISMD1-5B0180A-I20X PMSM			
Rated current:	0.49 A	Rated torque:	2.7 Nm
Rated voltage:	100 V	Rated frequency:	24.00 Hz
Rated speed:	180 r/min	Rated power:	50 W
Resistance of DC wire (20°C)	72±3.6 Ω	Wire inductance (20°C):	240±20% mH
Wire back EMF potential constant:	9.55±1 V/rad/s	Pairs of poles	8
Working mode:	S4	Usage environment	0–40°C
Insulation level	B	Ingress level:	IP44

9.1.2 Specifications

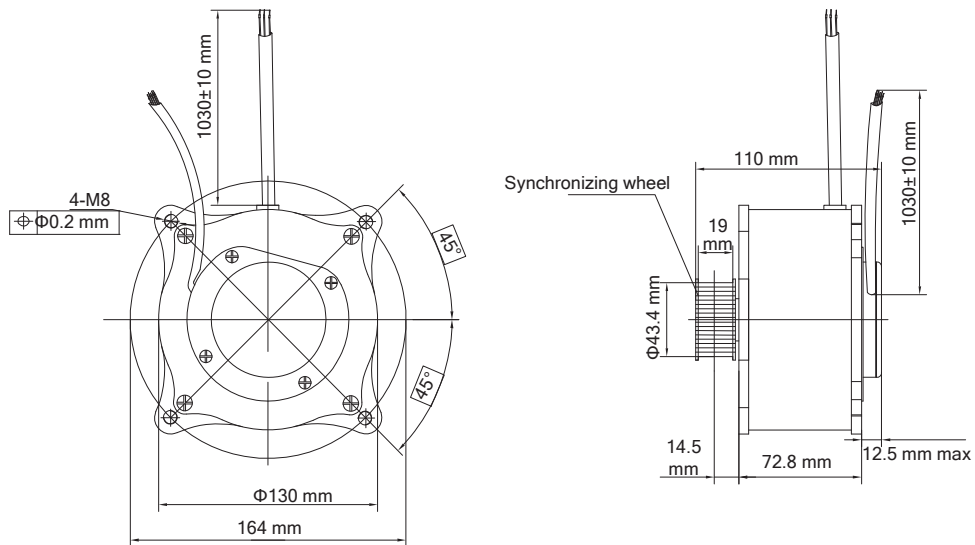

9.1.3 Definitions of the Power Wires

Blue	Yellow	Brown
U	V	W

9.2 Encoder Parameters

An encoder is installed for the ISMD1-5B0180A-I20X PMSM at factory delivery. Information and wiring of the encoder is provided in the following tables.

Encoder	
PPR:	1000
Input voltage:	Below 100 mA, range: DC 24 V±10%
Response frequency:	0–100 kHz
Terminal type:	72±3.6 Ω
Lead wire parameter:	9.55±1 V/rad/s
Operating temperature:	0°C to 70°C
Storage temperature:	-40°C to +80°C
Relative humidity	90%

Red	Black	Green	Yellow	White
VCC	GND	A	B	Z

The following figure shows the output pulse of the encoder.

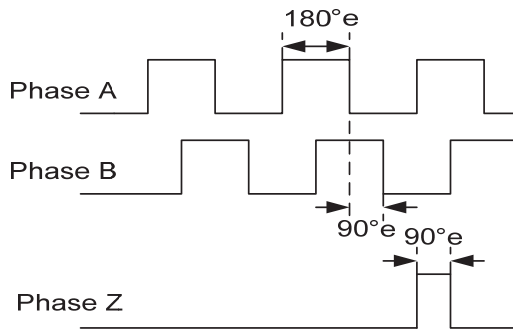

9.3 Guide to Motor Torque Calculation and Model Selection

Based on the torque balancing principle:

$$T = F \times R$$

Where, T is the motor torque, in the unit of Nm, F is the force required for opening and closing the elevator door, in the unit of N, and R is the radius of the synchronizing wheel, in a unit of m.

Take the ISMD1-5B0180A-I20X PMSM as an example. The rated load of the motor is:

$$\begin{aligned}
 F &= T/R \\
 &= 2.7/0.02 \\
 &= 135 \text{ N}
 \end{aligned}$$

The motor configuration basis is as follows:

1. Measure the force required for opening and closing the door based on the actual load and obtain the maximum value.
2. Measure the radius of the synchronizing wheel of the elevator door.
3. Calculate the motor torque based on the preceding formula.

NOTE:

Function code	Setting value	Function code	Setting value	Function code	Setting value	Function code	Setting value
F -	_____	F -	_____	F -	_____	F -	_____
F -	_____	F -	_____	F -	_____	F -	_____
F -	_____	F -	_____	F -	_____	F -	_____
F -		F -		F -		F -	
F -		F -		F -		F -	

Date Month Year

Location:

Dear users, thank you to use the products of Suzhou Monarch Control Technology Corp., Ltd. We are sincerely waiting for your valuable advice:

Monarch Control Technology Corp., Ltd. extends our sincere thanks to you.