

Contents

CHAPTER 1 SAFETY INFORMATION AND ATTENTION ITEMS	- 2 -
1.1 SAFETY ITEMS	- 2 -
1.2 ATTENTION ITEMS	- 5 -
CHAPTER 2 PRODUCT INFORMATION	- 10 -
2.1 NAME DESIGNATION RULES AND NAMEPLATE	- 10 -
2.2 MAIN PARAMETERS OF NICE3000 INTEGRITY CONTROLLER.....	- 11 -
2.3 TECHNICAL SPECIFICATION	- 12 -
2.4 PRODUCT APPEARANCE	- 14 -
2.5 DAILY MAINTENANCE OF CONTROLLER	- 15 -
CHAPTER 3 INSTALLATION AND WIRING	20
3.1 SYSTEM CONFIGURE INTRODUCTION	20
3.2 MECHANICAL INSTALLATION	20
3.3 ELECTRIC INSTALLATION AND WIRING	21
CHAPTER 4 INSTRUCTION OF ADJUSTING TOOLS.....	36
4.1 SORT OF ADJUSTING TOOLS FOR NICE 3000	36
4.2 OPERATION PANEL INSTRUCTION	36
4.3 FUNCTION AND USE INSTRUCTION OF SMALL KEYBOARD	- 42 -
CHAPTER 5 FUNCTION PARAMETERS TABLES	- 48 -
5.1 FUNCTION PARAMETERS INDICATION.....	- 48 -
5.2 FUNCTION PARAMETERS TABLES.....	- 49 -
CHAPTER 6 FUNCTION PARAMETER DESCRIPTION.....	- 78 -
6.1 F0 GROUP BASIC FUNCTION GROUP	- 78 -
6.2 F1 GROUP MOTOR PARAMETERS	- 80 -
6.3 F2 GROUP VECTOR CONTROL PARAMETERS.....	- 88 -
6.4 F3 GROUP RUNNING CONTROL PARAMETERS	- 91 -
6.5 F4 GROUP POSITION PARAMETERS	- 96 -
6.6 F5 GROUP TERMINAL FUNCTION PARAMETERS.....	- 97 -
6.7 F6 GROUP LIFT BASIC PARAMETERS	- 112 -
6.8 F7 GROUP TESTING FUNCTION PARAMETERS.....	- 116 -
6.9 F8 GROUP REINFORCE FUNCTION PARAMETERS	- 118 -

6.10 F9 GROUP	TIME PARAMETERS	- 121 -
6.11 FA GROUP	KEYBOARD SETTING PARAMETERS.....	- 122 -
6.12 FB GROUP	DOOR FUNCTION PARAMETERS.....	- 128 -
6.13 FC GROUP	PROTECTION FUNCTION PARAMETERS	- 131 -
6.14 FD GROUP	COMMUNICATION PARAMETERS.....	- 134 -
6.15 FE GROUP	LIFT FUNCTION SETTING PARAMETERS	- 135 -
6.16 FE GROUP	FACTORY PARAMETERS (RESERVED).....	- 144 -
6.17 FP GROUP	USER PARAMETERS	- 144 -
CHAPTER 7	SYSTEM TYPICAL APPLICATION AND ADJUSTMENT.....	147
7.1	LIFT ADJUSTMENT.....	147
7.2	PRODUCTION USE	160
7.3	NICE3000 INTEGRATED CONTROLLER WITHOUT WEIGHING APPLICATION NOTES.....	162
7.4	POWER FAILURE EMERGENCY RUNNING PROGRAM INSTRUCTION	163
7.5	PARALLEL PROGRAM INSTRUCTION.....	168
7.6	INSTRUCTION OF GROUP CONTROL PROGRAM	173
7.7	INSTRUCTION OF OVERLOAD AND FULL LOAD	174
7.8	INSTRUCTION OF PLURAL EXTERNAL CALL IN THE SAME FLOOR.....	176
CHAPTER 8	FAULT DIAGNOSIS AND COUNTERMEASURES	179
8.1	FAULT MODE EXPLANATION	179
8.2	FAULT INFORMATION AND COUNTERMEASURES	180
CHAPTER 9	INSTRUCTION OF ACCESSORY PRODUCTS	197
9.1	USING INTRODUCTION OF CTB	197
9.2	USING INTRODUCTION OF CCB	201
9.3	DIRECTION FOR USE OF HCB	207
9.4	WEIGHING TRANSDUCER (LDB)	213
9.6	OTHER OPTIONAL COMPONENTS	217

Preface

Thank you for using elevator integrated controller!

NICE 3000, the elevator integrated controller, is under the research and development of and produced by Suzhou Monarch Control Technology Co. Ltd. It's the new vector-based intelligent elevator integrated controller combining the elevator control with motor driver. NICE 3000 control system mainly consists of NICE 3000 elevator integrated controller, MCTC-CTB-A, MCTC-HCB-A, MCTC-GCB-A, and MCTC-IE-A.

Main features are as follows:

✓ **More advanced**

NICE 3000 including computer technology, Automatic control technology, Network communication technology, and Motor vector drive technology, is the Intelligent Control System with the advanced international level.

👍 Direct stopping technology with the principle of distance control; N curves generate automatically.

👍 The group control with less than 8 elevators is based on fuzzy control theory.

👍 Multi-CPU's redundantly control and integrate the advanced Canbus, Modbus, GSM communication technology.

👍 It provides with abundant time-sharing control function with accurate real-time clock built-in, thus it's convenient for the buildings to fulfill the intellectualized management.

👍 Flexible power failure rescue plans with either 48DC or 220VAC power input.

👍 It supports automatic identification operation between short floors.

✓ **Easier to use**

👍 It is compact combining with the control and driver system, facilitating the design of small elevator machine rooms and no machine rooms.

👍 The function parameters are designed easily, aiming to facilitate the adjustment to the large extent.

👍 The considerate design of small keyboards makes it easier to check up, maintain, and debug the elevator.

👍 It can weigh automatically according to the weight it bears.

👍 It supports many adjusting measures: computer monitoring software, PDA monitoring, and operation panel.

✓ **Safer and more reliable**

👍 Multi-security is assured closely following the GB7588-2003 standards.

👍 Fault-tolerant design of hardware and software; many types of fault treatment; maximize to eliminate accidents () to run safely.

👍 EU MP Laboratory provides professional testing to give all-round confrontation against electromagnetic interference.

👍 All-round confrontation against fluctuations in power grids, dust, high temperature and lightening.

✓ **More comfortable**

👍 Dedicated weighing compensating device offers near perfect compensation start.

👍 High capability of vector control makes the motor performance well which brings the feeling of comfort.

✓ **More economical**

👍 The integration makes the system easier to operate and cost less by reducing the outside wiring in a large amount. It improves the elevator's security and stability.

👍 Canbus and Modbus communication's perfect combination reduces the amount of cables in maximum.

👍 Flexible and adequate module value-added accessories

👍 Series of built-in DC Reactor and Brake Unit

👍 Three wires can make the interconnect, and there's no need of extra group boards.

Instruction of Elevator Integrated Control Function, NICE 3000

Serial Number	Function	Remark	Serial Number	Function	Remark
Standard functions					
1	Maintenance Operation		41	Current aslant remove	
2	Direct stopping		42	User setting inspection	
3	The best curve generated automatically		43	Peak service	
4	Self-rescue leveling running		44	Real-time clock management	
5	Attendant operation		45	time-sharing services	
6	Fire back to the base floor		46	Security floor at night	
7	Firemen Operation		47	Attendant diverting	
8	Testing running		48	Deputy operation panel operation	
9	Independent running		49	Car arrival chime	
10	emergency rescue running		50	Outside approaching lamp	Configure MCTC-H CB-B
11	re-leveling when the door is open	Configure MCTC-SCB -A	51	Outside arrival chime	Configure MCTC-H CB-B
12	Automatic back to the base floor		52	Double outside -call in the same floor	
13	Parallel Operation		53	forced deceleration monitoring function	
14	Group control adjustment operation	Configure MCTC-GCB -A	54	Call conglutination judgment	
15	Lift parameter identification with no load	(Permanent Magnet Synchronou s Machine is rotary	55	Weighing signal compensation	

Serial Number	Function	Remark	Serial Number	Function	Remark
		coder angle recognition			
16	Shaft parameters self-tuning		56	Leveling fine-tuning	
17	Staircase lock function		57	Next landing	
18	Full load by pass		58	Failure record	
19	lighting 、 fan energy-saving function		59	Short-circuit test against the earth	
20	Service floor set		60	Overload Protection	
21	Car location automatically correct		61	Door light curtain protection	
22	Cancel the wrong direction		62	Non-open outside door zone	
23	Reverse cancelling		63	Protection of reverse travel	
24	Floor service set for front door and back door		64	anti-slip protection	
25	Advanced open	Configure MCTC-SCB -A	65	Contact inspection protection of contactor	
26	Repetition of door closing		66	Motor over-current protection	
27	Open the door outside this hall		67	Power source over-voltage protection	
28	Closing button for door-closing in advance		68	Motor overload protection	
29	Choice of open and close the door control protection		69	Encoder fault protection	
30	Category setting for		70	Shaft auto-tuning	

Serial Number	Function	Remark	Serial Number	Function	Remark
	the time of keeping door open			failure judging	
31	Keep open function		71	Drive module overheat protection	
32	Outside-call display by bit		72	Door switch fault protection	
33	Rolling show the direction of running	Configure MCTC-HCB -H	73	protection of door-lock disconnect when running	
34	Dot matrix display lift status	Configure MCTC-HCB -H	74	limit switch protection	
35	Show jumping floor	Configure MCTC-HCB -H	75	Over-speed protection	
36	Anti- nuisance function	Configure car weighing equipment	76	leveling switch fault protection	
37	Full selective		77	CPU fault protection	
38	Up selective		78	Output contactor abnormal detection	
39	Down selective		79	Door lock jump protection	
40	Separate wait				
Optional function					
1	IC card user management		7	toggle group control lift Service floor	
2	Quarter monitoring	Configure MCTC-BMB -A	8	nudging	
3	Motor temperature protection		9	VIP floor Service	
4	voice announcement		10	Handicapped operation box operate	
5	Earthquake function		11	Back door operation	

Serial Number	Function	Remark	Serial Number	Function	Remark
				panel operate	
6	front and back door independent control				

Attention:

- 1) The standard function is product's standard configured function, the optional function is the specially provide software service.
- 2) Our company does not charge additional for the software part in the optional function.

Function Explanation

Standard Function			
Serial number	Function name	Function introduction	Remark
1	Maintenance Operation	Elevator access to the overhaul state, the system automatically canceled and the operation of automatic doors. By the upper (lower) line will enable the elevator button to overhaul the speed of movement of the point (down) operation. Release the button to stop the lift immediately	Standard Settings
2	Direct stopping	To the principle of distance, Automatically generate the smooth curves from start to of parking, no crawling, directly stop in the flat layer.	Standard Settings
3	The best curve generated automatically	Systems automatically computing the most suitable for the principle of human-machine function curve according to the distance needed to run, and is not subjected to restrictions on short floor and the number of constraints	Standard Settings
4	Self-rescue leveling	When the elevator is in a state of non-maintenance, and did not stop at the leveling. If it meets the safety requirements to run .the lift will automatically run slowly to the nearest floor area, and then open the	Standard Settings

Standard Function			
		door	
5	Attendant operation	Through the toggle switch in operation panel can choose the driver operation, the driver can choose the direction and other functions (such as straight running function) The elevator close the door under the condition of the driver sustained press the close button.	Standard Settings
6	Fire back to the base station	Receive the fire signal, the elevator will not respond to any calls and inside command .the elevator run the fastest way to the fire station and then open the door and stop	Standard Settings
7	Firemen Operation	In the operation of fire mode, the door does not automatically open or close. Only press the button can make the door action. The lift only response to one command in car once. Only when the elevator open the door stopped at the base station , reset the fire switch and fireman switch, the lift can run normally	Function Selection
8	Testing running	Test run including new lifts fatigue test run, ban the door action ,ban respond to outside-call , shielding of end station limit switch, shielding of overloading signal,etc	Function Selection
9	Independent running	Elevator does not response to outside –call and close the door automatically (when the elevator in parallel control and group control, In order to supply special services for specific persons to carry VIP persons or goods. Press the independent running button then the elevator out of group control, independent running)	Function Selection
10	emergency rescue running	For the elevator motor which Human force upgrading the car with rated load lager than 400N Set emergency electrical running switch and operation to replace manually upgrading.	Function Selection
11	re-leveling when	The lift stop at the floor station, a large	Configure

Standard Function			
	the door is open	number of persons or goods entering and leaving, The leveling fluctuated because of the elastic deformation of elevator Wire Rope and the rubber. System allows run automatically at the speed of re-leveling to leveling station in the state of the door opened	MCTC-SCB -A
12	Automatic back to the base floor	when beyond the setting time and there is no inside-call and outside-call ,elevators automatically return to the base station and wait for passengers	Standard Settings
13	Parallel Operation	Two elevators through Serial communication (can bus) for data transmission. coordinate outside-call and improve operational efficiency	Function Selection
14	Group control adjustment operation	Multiple elevators through Serial communication (can bus) for data transmission. Calculate the most efficient and effective operation mode in response to outside calls.	Configure MCTC-GC B-A
15	Motor parameter auto-tuning with no load	For induction motors control system can automatically recognize the motor resistance, inductance, control parameters, no-load current to accurately control the motor. As for the permanent magnet synchronous motor, control system can identify the angle of rotary encoder	Permanent magnet synchronous motor for identify the rotary encoder angle
16	Shaft parameters of self-tuning	Before the first run, system must self-learn the well parameters. Including the story on each floor, forced deceleration switch, limit switch position.	Standard Settings
17	Staircase lock function	In automatically run state, after the elevator locked, the system eliminates all calls registered and then return to elevator-locked base station then open the door. After that the elevator stops running, closing the light and fan in car. When the lock switch has been	Standard Settings

Standard Function			
		reset the elevator re-entered to normal service state.	
18	Full load by pass	Under the condition of run automatically without the driver, when the car with full load (generally is 80 % rated load) the elevator does not respond to outside-calls in passing floor. However, this time outside-calls can still be registered; it will be serviced next run-time (single control), or by other elevator services (group control)	Standard Settings
19	lighting 、 fan energy-saving function	When beyond the setting time and there is no inside-call and outside call the elevator will automatically turn off the light and fan in car	Standard Settings
20	Floor service set	System can be flexible choose to shut down or activate one or more elevators service floors and stop floors for its own needs	Function Selection
21	Car location automatically correct	when the elevator run to the end station ,the system automatically inspection and rectification of the location information based on the first level forced deceleration switch .At the same time, assisted by a special rate of forced deceleration	Standard Settings
22	Cancel the wrong direction	Passengers can press the command button continuously twice in the control box to cancel the last error registration instructions.	Standard Settings
23	Reverse cancelling	When the elevator run to the end floor or the direction changed, system cancel all calls registered of the reverse directions.	Standard Settings
24	Floor service set for front door and back door	System can select service floors respectively through the front door and back door for its own needs	Function Selection
25	Advanced open	Under the automatic operation state , the speed during stopping is less than 0.1m/s and the gate signals effective, system shorted door-lock signal through door-close contactor and then open the door ahead of time to make the elevator efficiency	Configure MCTC-SCB -A
26	Repetition of door	After the elevator continuing close the door	Standard

Standard Function			
	closing	for a certain time, If the door-lock has not been closed, the elevator opens the door automatically, and then repeats the close the door.	Settings
27	Open the door outside this hall	under the condition that there is no other command or outside-call ,if the car stop at a floor, press the call button this floor, the door automatically open	Standard Settings
28	Closing button for door-closing in advance	when Elevator in the automatic operation mode and the door is open, it can through the close button to close the door ahead of time to make the elevator efficiency	Standard Settings
29	Choice of open and close the door control protection	System can flexible set whether continuous output commands after open the door in place, closed in place in accordance with the type of door	Function Selection
30	Category setting for the time of keeping door open	System can automatically identify different time to keep the open of calls to open the door, instructions to open the door, the door to protect open, delay to open the door to open the door in accordance with the setting time	Standard Settings
31	Keep open function	By press the keeping the door open button ,the elevator delay closing to meet the need of carrying goods	Standard Settings
32	Hall call display by bit	System allows the display of each floor using the 0-9, as well as any letters of permutation and combination of characters for use of the special conditions.	Standard Settings
33	Rolling show the direction of running	During the elevator running, the display outside shows the direction of running	Configure MCTC-HC B-H
34	Dot matrix display lift status	through the dot matrix it shows the direction of the elevator, the floor elevator stops, elevator status(such as failure, overhaul) etc.	Configure MCTC-HC B-H
35	Show jumping floor	flexible defining the outside display panel display ,show non-continuous data for its own needs	Configure MCTC-HC B-H

Standard Function			
36	Anti-nuisance function	System identifies the number of passengers in car and Automatically determines the number of passengers inside and comparison with the instructions registered in car. If an excessive number of calls registered, then the system considers it is anti-nuisance status and cancels all the calls in car. You need to re-register correct calls	Configure Car weighing equipment
37	Full selective	when the elevator running in automatic or driver state will be responded to inside-call signal meanwhile responded to outside-call button signals, any service floor can call the elevator by register the up and down signal	Standard Settings
38	Up selective	when the elevator running in automatic or driver state will be responded to inside-call signal meanwhile responded to outside-call button signals, any service floor can call the elevator by register the up signal	Function Selection
39	Down selective	when the elevator running in automatic or driver state will be responded to inside-call signal meanwhile responded to outside-call button signals, any service floor can call the elevator by register the down signal	Function Selection
40	separate wait	only the system with parallel or group control can select this function, when elevators in parallel or group control in the same floor, parallel or group control will began to spread the elevators, make the elevator run to the free floor	Function Selection
41	Current aslant remove	when use permanent magnet synchronous motor, after the elevator decelerating and stopping, the maintain current of the motor removed by the slope way to abnormal noise of the motor during the process	Function Selection
42	User Preferences inspect	Users can find the system parameters which is different from the factory parameters by this function	Function Selection
43	Peak service	Parallel peak is in the peak time set, if the	Function

Standard Function			
		inside-call from this peak floor more than 3, then system in peak service. the inside-call effective all the time, the elevator is free it will be go to this floor	Selection
44	Real-time clock management	System have real-time clock chip to guarantee the clock work normal in 2-years	Function Selection
45	time-sharing services	Flexible setting the time-sharing service time period and the corresponding time-sharing service floors.	Function Selection
46	Guard floor at night	Protect floor of elevator, when 22 o'clock to 6 o'clock the Protect floor is valid, the elevator will be running to the Protect floor every time when the elevator running, stop at the protect floor to open the door and then run to the purpose floor to improve security	Function Selection
47	Drivers reversing	Drivers choose the direction of the elevator through a special button	Standard Settings
48	Deputy operation panel operation	manipulation matching box can be selected if the system have the main control box, the manipulation matching box also equipped with a command button and the door button switch and the function is the same as the main control box	Standard Settings
49	Car arrival chime	After the elevator arrival at the destination floor in accordance with the requirements of passengers, the car roof board sent the signal.	Standard Settings
50	Outside approaching chime	After the elevator reach the floor, through MCTC-HCB-B sent outside lights arrival forecasting	Configure MCTC-HC B-B
51	Outside arrival chime	After the elevator reach the floor, through MCTC-HCB-B sent outside clock arrival forecasting	Configure MCTC-HC B-B
52	Double hall call in the same floor	Double outside-call can be set when opposite door in the same floor	Function Selection
53	Forced deceleration	System in automatic operation mode correcting the location of the elevator car	Standard Settings

Standard Function			
	monitoring function	according to the forced deceleration switch position , as well as the action switches to monitor the situation	
54	Call conglutination judgment	System can identify the conglutination situation of the hall call button, automatically remove the call of the adhesion to avoid the elevator can not be closed to run caused by the outside-call button adhesion	Function Selection
55	Weighing signal compensation	in high-end applications System can use weighing signal to compensate the start of the elevator	Function Selection
56	Leveling fine-tuning	system can be fine-tune the accuracy of leveling by adjust the f4-00 parameter	Standard Settings
57	Next landing	If the elevator continued to open the door more than the time of open the door, the open limit has not yet been act, the elevator would be turned into the closing door state, and after the door closed, automatically run the next registered floor	Standard Settings
58	Failure record	System recorded 11 failures, including failure resulting from information such as time and floors.	Standard Settings
59	Short-circuit test against the earth	When first supply power, the system test output U, V, W to determine whether the existence of short-circuit fault.	Standard Settings
60	Overload Protection	When the lift when the load over the rated load; elevator alarm, stop the run. .	Standard Settings
61	Light curtain protection	When something block in the middle of the door during the door is closing, the light curtain protection action then the elevator turn to open the door. But the light curtain protection does not work in the fire operation.	Standard Settings
62	Non-open outside door zone	Prohibit open the door automatically when system not in gate-area	Standard Settings
63	Protection	System identify the direction of rotary	Standard

Standard Function			
	against reversal travel	encoder feedback signals, determining the actual direction of the motor in operation, once the signal reversed the system will be alarm	Settings
64	Anti-slip protection	When the elevator not running in overhaul state, if the elevator continuous running beyond the F9-02 set time (maximum 45 seconds) and the leveling switch not act. system will regard this as detect the rope slip fault, so stop the car all running	Standard Settings
65	Trigger point detection protection of trigger	if system detect the contactor on abnormal state when the elevator in running or stopping state, the system will automatically protect	Standard Settings
66	Motor over-current protection	When detecting the motor current value is greater than the maximum allowable, the system automatic protection	Standard Settings
67	Power source over-voltage protection	When Detecting the power supply voltage is greater than the maximum allowable value, the system automatic protection	Standard Settings
68	Motor overload protection	When detecting the motor is overload ,the system automatic protection	Standard Settings
69	Encoder fault protection	System only use a high-speed encoder for closed loop vector control, if the encoder failure, the system stop automatically to avoid the runaway failure which caused by the encoder failure not available.	Standard Settings
70	shaft auto-tuning failure judgment	Without right well data, the elevator will not be able to running. so we set the self-learning fault diagnostic if the well self-learning does not properly completed	Standard Settings
71	Drive module overheating protection	When detecting the drive module overheating, the system automatic protection	Standard Settings
72	Door switch fault protection	When detecting the elevator not yet close the door effective after the elevator open and	Standard Settings

Standard Function			
		close the door beyond the number set, system stop close and open the door switch and output the fault.	
73	Protection of door-lock disconnect when running	when the door-lock disconnected during the elevator is running, the system automatic protection	Standard Settings
74	Limit switch protection	If the Up (down) limit switch action, the elevator ban on run to up(down),but to run to the opposite direction	Standard Settings
75	Over-speed protection	Assurance the speed of car in the range of security speed to ensure the passengers and cargo security.	Standard Settings
76	leveling switch fault protection	When the elevator in the automatic running mode, it identify leveling signal loss and adhesion status.	Standard Settings
77	CPU fault protection	System has three CPUs to judge state each other, if there is abnormal, the system block all output.	Standard Settings
78	Output contactor abnormal detection	By detecting the output current situation to determine whether the output contactor is abnormal before the brake open.	Standard Settings
79	Protection against false door locking	Elevator in the automatic running mode identify whether the door-lock is anomalies every time open the door in place	Standard Settings
Optional function			
Serial number	Function name	Function introduction	Remark
1	IC card user management	Passengers must be licensed before they can reach the authorized floor	
2	Quarter monitoring	Through communication lines, control systems connect to the terminals installed in the control room to display the elevator location, direction, fault status and so on.	Configure MCTC-BMB-A
3	Motor temperature	when System detects motor temperature overheating, suspend the elevator running	

Standard Function			
	protection		
4	voice announcement	when the elevator running ,it will automatically broadcast to the direction of running and the floor next reaching and other information passengers	
5	Earthquake function	If the earthquake happens, earthquake detection devices act. the device has a contact signal input to the NICE system, the system will control the elevator stop at the nearest floor and then open the door stop running	
6	front and back door independent control	the front and back door (front and back doors operation panel, the front and back doors call box exist) independent control operation: If the back door call-box (or back-door directions) call registered this floor before leveling, open the back door when the elevator stop; If the front door call-box (or front-door directions) call registered this floor before leveling, open the front door when the elevator stop. If registered both side, open two doors. In this floor, similarly, open the back door when press the button on back door call-box, open the front door when press the button on front door call-box.	
7	switch group control lift Service floor	freely set up service floor Based on time parameters	
8	nudging	When nudging function effective, if there are no close signal in continuing 60 seconds because light curtain act or other reason. the elevator will nudging and sent the nudging signal	
9	VIP floor Service	when need VIP service, click the VIP switch and the elevator will carry out a VIP service operation: cancel all the call and registered command ,the elevator straight	

Standard Function			
		run to VIP floor and open the door. The elevator can't close the door automatically and can't register outside-call but can registered inside-call. service who escort the VIP register the purpose floor command, sustaining press the close button to make the door closed ,the elevator straight to the destination floor, open the door and then the elevator turn to normal	
10	Handicapped operation box operate	when the elevator wait in leveling position, if call from handicapped operation panel registered in this floor, then the time which the elevator keep the door open extend; similarly, if the door open after press the open button on handicapped operation panel, the time is also extend	



Safety information and attention items

Chapter 1 Safety information and attention items

Safety definition:

There are two kinds of safety items in this manual:



Failure to follow these instructions will result in death or serious injury



Failure to follow these instructions will result in moderate hurt or equipment damage

Please read this manual carefully and operate strictly according to the safety items while installing, debugging, maintaining the system. Our company is free of charge to any damage or dandification caused by the operation not performed according to the requirements.

1.1 Safety Items

1.1.1 before Installation



- Do not install in the condition of water seepage in the control system, components scarcity or damage while opening the case!
- Do not install while the packing list is not according with the practicality!



- Please uplift and drop gently in the portage or the equipment will be damaged!
- Do not use any controller that is damaged or not complete. There's danger of getting hurt!
- Do not touch the elements of the controller with your hands, or the static electricity damage may be caused!

1.1.2 during Installation



- Please mount the controller on incombustible surface like metal, and keep away from flammable substances! Otherwise it may cause fire!
- Do not twist the fixing bolts of the components, especially the bolts with red marks!

 **Note**

- Do not let wiring terminal or screw enter the controller, otherwise the controller will be damaged!
- Install the controller where there's less shaking and less sunshine.

1.1.3 Wiring

 **Danger**

- Only the qualified electrical engineer can perform the wiring, otherwise there will be danger of electric shock.
- A circuit breaker must be installed between the mains and the controller; otherwise there will be danger of fire.
- Wiring can only be done after the mains input are cut off; otherwise there will be danger of electric shock.
- Please connect the controller to the ground according to the standard, otherwise there will be dangerous

 **Danger**

- Do not connect the input terminals with the output terminals (U, V, W). Please note the marks and do not connect the wrong wires otherwise the controller may be damaged!
- Ensure the wiring meet the EMC requirements and the local safety standard. The wire size shall be determined according to the manual, otherwise accidents may occur!
- Brake resistor must not be connected between the DC bus terminals (+) and (-), otherwise fire may occur!
- Encode connection must use Shielded line, shielding layer must be one side connected to earth reliably!
- Communication wires must use STP with the length of the lay between 20mm and 30mm, shielding layer must be connected to earth!

1.1.4 before Power-on

 **Note**

- Please confirm the mains voltage level is consistent with that of the controller ;the input (R,S,T) and output (U,V,W) wirings are correct; and check if there is any short circuit in peripheral circuit and if the wiring is fixed and fast; otherwise the controller may be damaged!

- Ensure the synchronous motor has done the dynamic auto-tuning and try to run the motor before restoring wire ropes.
- No parts of controller must be through the overpressure testing since it has been done in the factory; Otherwise accidents will occur!



- Mount the cover plate properly before power-on the controller; otherwise there will be danger of electric shock!
- All the external equipment wirings must be connected according to the instruction of this manual, or accidents may occur!

1.1.5 after Power-on



- Do not open the cover of the controller after power-on; otherwise there will be danger of electric shock!
- Do not touch the controller and its circuit with wet hand; otherwise there will be danger of electric shock.
- Do not touch the controller terminals; otherwise there will be danger of electric shock.
- At power-on, the controller will perform the security check of the external heavy-current circuit. At this time do not touch U, V, W terminals of controller or the wirings terminals of the motor; otherwise there will be danger of electric shock!



- If parameter identification is required, please pay attention that the rotating motor may injure people, otherwise accident may occur!
- Do not change the factory settings; otherwise the current may be damaged!

1.1.6 Running



- Do not touch the fan and the discharging resistor to check the temperature, otherwise burning will occur!
- Only the qualified technician can check the signal while it's running. Otherwise there will be danger of personal injury or equipment damage!

Note

- Do not let objects fall into a running controller; otherwise the controller may be damaged!
- Do not start and stop the controller by on/off of the contactor, otherwise the controller may be damaged.

1.1.7 Maintenance**Danger**

- Please do not repair or maintain the controllers with power on, otherwise there will be danger of electric shock!
- Ensure the repair and maintenance of the controller is operated in the condition that the controller voltage is below AC36V, two minutes after the power is switch-off. Otherwise the residual Charge in the capacitor will injure people.
- Only qualified electrical engineer can repair or maintain the controller, otherwise there will be danger of human injury or damaging the equipment.
- Reset the parameters after changing the controller; all the insets must be unplugged while the power is switch-off!

1.2 Attention Items**1.2.1 Motor insulation check**

When the motor is used for the first time, or reused after storing for a long time, or in a regular checkup, the user must check the insulation of the motor to prevent the poor insulation of the windings of motor from damaging the controller. The motor connection must be divided from the controller during the insulation check. It is recommended to use a 500V Mega-Ohm-Meter to check and the insulation resistance shall not be less than 5M Ω .

1.2.2 Thermal Protection of Motor

If the rated capacity of the motor selected is not matching that of the controller, especially when the rated power of the controller is bigger than that of the motor, make sure to adjust the parameters for motor protection inside the controller or to install a thermal relay to the motor to guarantee the protection to the motor.

1.2.3 Motor Heat and Noise

Since the output voltage of the controller is in PWM wave with some harmonic wave, the temperature may raise, the noise and vibration may increase compared with the controller running at main frequency.

1.2.4 Pressure-sensitive Device or Capacitor at the Output Side of the Controller

Because the controller outputs PWM wave, the capacitor used for improving power factor and pressure-sensitive resistor used for lightening-proof shouldn't be installed at the output side of the controller. Otherwise the controller may have transient over-current and may be damaged.

1.2.5 Switches Used at the Input and Output terminal of the Controller

If the contactor is required to be installed between the controller input terminal and the power supply, it is prohibited to start or stop the controller with the contactor. If the switches like contactors are connected between the output terminal and the motor, make sure to start and stop the controller when the controller has no outputting, otherwise the modules in the controller may be damaged.

1.2.6 Usage out of the Range of Rated Voltage

The NICE3000 controller shall not be used out of the specified range of operation voltage. Otherwise the internal components of the controller may be damaged. If needed, please use corresponding voltage regulation device to change the voltage.

1.2.7 Lightning Strike Protection

There are lightning protection devices inside the controller, but the user should install other lightning protection device at the front end of the controller if lightning strike occurs frequently.

1.2.8 Altitude and De-rating

When the altitude is higher than 1000m, the cooling effect of consult is deteriorated because of the rarefaction of air, then it is a necessity to de-rate the use of controller and please contact our company for detailed technical support in this circumstance.

1.2.9 Cautions for Scrap of controller

The electrolytic capacitors in the main circuits and PCB may explode when they are burned and poisonous gas may be generated when the plastic parts are burned. Please dispose the controller as industrial rubbish.

1.2.10 About Applicable Motor

- 1) The controller is applicable to squirrel-cage Asynchronous motor and AC permanent-magnet Synchronous motor. Please be sure to select the applicable controller according to the Data plate of the motor.
- 2) The controller has already been configured with default parameters which is applicable to squirrel-cage Asynchronous motor. To perform the motor parameter identification according to the actual conditions will promote the operation effect. Synchronous motor must carry out parameter tuning.
- 3) The output part of controller should not be short. Otherwise the controller may alarm or be damaged. Therefore, before Power-on, we must execute short-circuit-test for new elevator. Please make sure that the controller be cut from the testing parts when the testing is undergoing..



Product information

Chapter 2 Product information

2.1 Name Designation Rules and Nameplate

2.1.1 Applies to Asynchronous/ Synchronous integrated motor:

Name designation rules:

NICE - L - A - 40 11



Controller model	A	B	
Applicable to traction motor model	Asynchronous motor	Synchronous motor	
Applicable to encoder motor model	Push-pull, open-circuit collector output incremental encoder	UVW	SIN/COS
Applicable to PG card	No need of PG card	MCTC-PG-B MCTC-PG-D	MCTC-PG-C MCTC-PG-E

NICE-L-A-40XX is used in asynchronous traction motor control, and is applicable to push-pull output and open-circuit output incremental encoder. The main control panel has push-pull encoder itself, so it doesn't need PG switch card. NICE-L-B-40XX is used in synchronous traction motor control, and is suitable for UVW encoder and SIN/COS encoder.

Note: NICE-L-B-40XX is the replacer of NICE-L-IP-40XX and NICE-L-IP-40XX-SC, and has upgraded on the basis of them.

2.1.2 Asynchronous/ Synchronous integrated controller nameplate:

Asynchronous motor nameplate:

MODLE	NICE-L-A-4015
POWER	15kW
INPUT	3PH AC380V 35A 50Hz/60Hz
OUTPUT	3PH AC380V 32A 0~90Hz
S/N	
Suzhou MONARCH Control Technology Co.,Ltd.	

Synchronous motor nameplate:

MODLE	NICE-L-IP-4015
POWER	15kW
INPUT	3PH AC380V 35A 50Hz/60Hz
OUTPUT	3PH AC380V 32A 0~90Hz
S/N	
Suzhou MONARCH Control Technology Co.,Ltd.	

2.2 main parameters of NICE3000 integrity controller

Model	Input Voltage	Power Capacity(KVA)	Input Current (A)	Output Current(A)	Motor(KW)
NICE-L-A/B-2002	single phase 220V range: -15%~ 20%	4	13.2	5.5	1.1
NICE-L-A/B-2003		5.9	17	9.0	1.5
220-NICE-L-A/B-4007		17	29	10.3	5.5
220-NICE-L-A/B-4011		21	36	15.5	7.5
220-NICE-L-A/B-4015		24	41	19	11
220-NICE-L-A/B-4018		30	49.5	22.5	15
220-NICE-L-A/B-4022		40	62	27.7	15
220-NICE-L-A/B-4030		57	77	34.6	22
NICE-L-A/B-2002	three phase 220V range: -15%~ 20%	4	13.2	9.6	3.7
NICE-L-A/B-2003		5.9	17	15.6	5.5
220-NICE-L-A/B-4007		17	29	18	11
220-NICE-L-A/B-4011		21	36	27	15
220-NICE-L-A/B-4015		24	41	33	22
220-NICE-L-A/B-4018		30	49.5	39	22

Model	Input Voltage	Power Capacity(KVA)	Input Current (A)	Output Current(A)	Motor(KW)
220-NICE-L-A/B-4022	three phase 380V range: -15%~ 20%	40	62	48	22
220-NICE-L-A/B-4030		57	77	60	22
NICE-L-A/B-4002		4	6.5	5.1	2.2
NICE-L-A/B-4003		5.9	10.5	9	3.7
NICE-L-A/B-4005		8.9	14.8	13	5.5
NICE-L-A/B-4007		11	20.5	18	7.5
NICE-L-A/B-4011		17	29	27	11
NICE-L-A/B-4015		21	36	33	15
NICE-L-A/B-4018		24	41	39	18.5
NICE-L-A/B-4022		30	49.5	48	22
NICE-L-A/B-4030		40	62	60	30
NICE-L-A/B-4037		57	77	75	37
NICE-L-A/B-4045		69	93	91	45

2.3 Technical Specification

Item		Specification	
Specification	Maximum frequency	90HZ	
	Carrier frequency	0.5k~16k (HZ); Carrier frequency can be adjusted automatically according to the load characteristic.	
	Control mode	Split-ring vector control (SVC)/ Closed loop vector control (VC)	
	Start torque	Type G: 0.5Hz / 180% (SVC), 0Hz/200% (VC)	
	Speed control range	1 : 100 (SVC)	1 : 1000 (VC)
	Speed accuracy	±0.5%(SVC)	±0.05%(SVC)
	Torque control accuracy	±5%(VC)	
	Overload capability	150% rated current for 60 seconds; 200% rated current for 1 second.	
	Motor tuning	No-load tuning, load tuning	
	Distance control	Immediacy stop	
	Acceleration/deceleration curve	N curves can generate automatically.	
Re-leveling	Level re-adjusts after the car load changes		

Item		Specification
	Forced deceleration	New and reliable compulsive deceleration function helps to identify the deceleration shelf automatically.
	Shaft auto-tuning	32-bit data, record the shaft position accurately.
	Leveling adjustment	Flexible and easy leveling adjustment function
	Starting torque compensation	Humanized weighing self-learning
	Real time clock	Based on accurate real time clock, it can accomplish time-sharing service, pinnacle service, automatic password, etc.
	Testing function	Convenient ways to realize many functions for elevator adjusting.
	Failure protect	Provide 53 kinds of protection such as electrify short circuit survey、in-out lack phase protect、over current protect、prevent encoder and so on. A complete elevator fault-dealing system
	Intellectualized management	Fulfill the function of distance monitoring, user management, and group adjustment.
	Apply power then peripheral equipment safety auto-examination	Apply power and do peripheral equipment detection like grounding、short circuit etc.
	State monitoring	According each feedback signal to judge elevator work state, ensure the elevator work effectively.
Input/output characteristic	Digital input	24 Digital input terminal, specification: 24V, 5mA
	Analog data input	A1 input terminal voltage range:-10V~10V
	Communication terminal	Canbus (car top) \ Modbus (hall call)
	Output terminal	6 relay output terminal, adjustable function
	Encoder interface	Standard adoptable to incremental push-pull output and open-loop collector output. coder . Applicable to different encoder via PG card.
Display and keypad	operation panel	5-bit LED display, show parameters of running speed, bus voltage, etc.
	small keyboard	3-bit LED display, displaying the information of main board MCB and receiving the simple order input
	State monitor	Monitor lift state parameters, including car top

Item		Specification
Application environment		control board and hall call control board.
	Elevation	Lower than 1000m
	Ambient temperature	-10℃~ +40℃ (ambient temperature is within 40℃~ 50℃ , and duration is required)
	Humidity	Less than 95% RH, without condensation
	Vibration	Less than 5.9m/s ² (0.6g)
	Storage temperature	-20℃ ~ +60℃

2.4 Product Appearance

NICE3000 controller has three sizes of models: size-C, size-D and size-E, details are as the following:

Model		A (mm)	B (mm)	H (mm)	W (mm)	D (mm)	Aperture (mm)	Gross weight (kg)
Size-C	NICE-L-A/B-2002	140	344	355	220	150	6.5	10
	NICE-L-A/B-2003							
	NICE-L-A/B-4002							
	NICE-L-A/B-4003							
	NICE-L-A/B-4005							
Size-D	NICE-L-A/B-4007	150	334.5	347.5	223	167.5	6.5	12
	NICE-L-A/B-4011							
	NICE-L-A/B-4015							
Size-E	NICE-L-A/B-4018	235	541.5	554.5	289.6	223	6.5	14.5
	NICE-L-A/B-4022							
	NICE-L-A/B-4030							

Note: products with other power rank, such as higher than 37kw, due to little usage, we don't list here. If you need them, please contact our company.

Controller has two types of size: Size D and Size E.

Size D (Chart a) includes NICE-L-A/IP-4007; NICE-L-A/IP-4011; NICE-L-A/IP-4015;

Size E (Chart b) includes NICE-L-A/IP-4018; NICE-L-A/IP-4022; NICE-L-A/IP-4030; NICE-L-A/IP-4037; NICE-L-A/IP-4045.

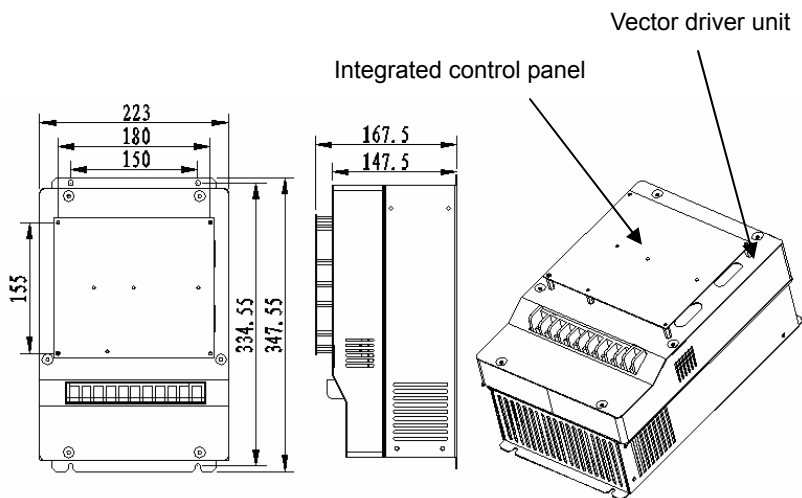

(a) Size D

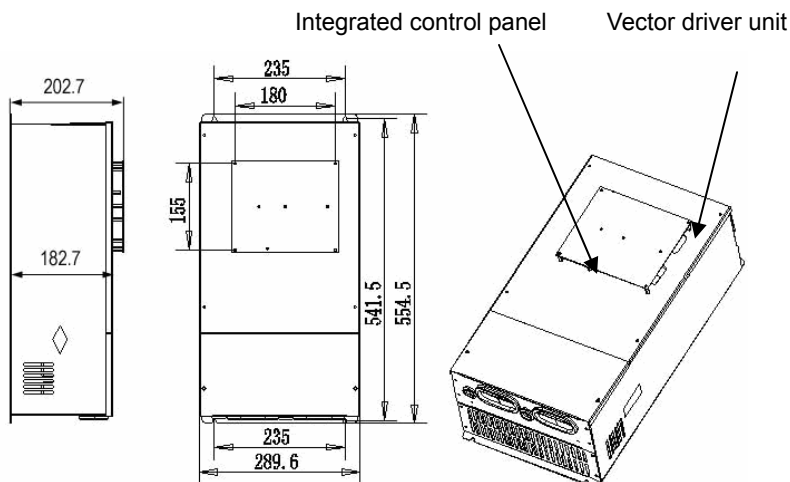

(b) Size E

2.5 Daily Maintenance of Controller

Since the influence of ambient temperature, humidity, dust, and vibration, the components in controller may become aging and wearing, which will

give rise to the occurrence of potential faults and reduce the life of controller. Therefore, it is quite necessary to do the work of daily maintenance of controller.



The filter capacitor still has high voltage after the power supply to the controller is switched off, so do not maintain or repair the controller until the bus voltage measured after 2 or 3 minutes with the multi-meter. The voltage must be lower than 36V.

2.5.1 Daily Maintenance

- 1) Daily checking items:
 - a) Check if there is any abnormal noise during the running of motor;
 - b) Check if there is any vibration of motor ;
 - c) Check if the installation environment of controller changes ;
 - d) Check if the cooling fan of controller works normally ;
 - e) Check if the controller is over heated.
- 2) Daily Cleaning:
 - a) Keep the controller in a clean status;
 - b) Clean the dust from the controller and prevent the dust especially the metal powder from entering the controller;
 - c) Clean the oil dirt in the cooling fan of the controller.

2.5.2 Periodical Checking

Periodically check the places that are hardly checked during the running.

- 1) Periodical Checking Items
 - a) Check the ventilation channels and clean them periodically;
 - b) Check if the screws are loose;
 - c) Check if the controller is rusted;
 - d) Check if the input / output terminals has scratch marks;
 - e) Check the insulating in main circuit.

Note: Insulation test (use 500V Mega-Ohm-Meter) should be done separately after disconnecting the input power cables from the controller; or else, the controller will be damaged. Do not use the Mega-Ohm-Meter to test the insulation of control circuits. Dielectric strength test had been done at factory. Therefore, user need not do this test again.

2) Replacement of aging Parts

The wearing parts of controller mainly include the cooling fan and filtering electrolytic capacitor. Their lifetime is closely related to the operating environment and maintenance.

General lifetime as follows:

Component	Lifetime
Fan	2 ~ 3 years
Electrolytic capacitor	4 ~ 5 years

Users could determine when to replace them according to their working time.

1) Cooling fan

Possible damage causes: shaft bearing attrition and blade aging.

Criteria: no crack on fan blade, no abnormal vibration noise at start.

2) Filtering electrolytic capacitor

Possible damage causes: high ambient temperature, big pulsating current due to frequent load fluctuation, electrolyte aging.

Criteria: no liquid leak, no protrusion of safety valve, electrostatic capacitance measurement, and insulation resistance measurement.

2.5.3 Controller Storage

The following points must be noticed in controller storage:

- 1) It is recommended to store the controller in its original packing box.
- 2) Long-term storage will cause deterioration of electrolytic capacitor. Therefore, controllers not in service for a long time must be powered for at least once within 2 years for testing purpose, at least for 5

hours ; in the test , the input voltage must be boosted gradually with voltage regulator to the rated value.



Installation and wiring

Chapter 3 Installation and wiring

3.1 System Configure Introduction

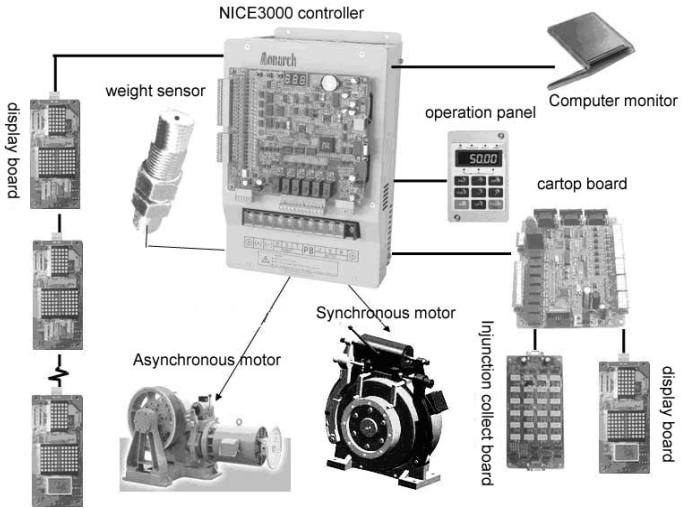

Chart 3-1 System Configure Diagram

3.2 Mechanical Installation

NICE 3000 controller installation size requirements:

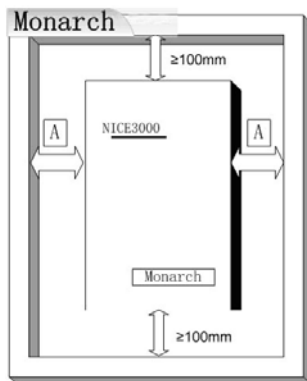

Chart 3-2 controller installation size requirements

The unit in the chart is mm.

A shall be bigger than 50mm for the controller of 22kW or above.

3.3 Electric Installation and Wiring

3.3.1 Using of External Device

Device	Position	Function
Air switch	Front-end of input circuit	Cut off the power and provide short protection.
safe contactor	between air switch and controller	Switch on/off the controller; controlled by safe circuit.
AC input reactor	Controller input side	improving input power factor; eliminate high frequency humorous wave in input side; eliminate current unbalance due to input phase unbalance;
DC reactor	standard internal	improving input power factor; eliminate high frequency humorous wave in input side; eliminate current unbalance due to input phase unbalance;
AC output	Between controller	If the distance between the vector driver and the

Device	Position	Function
reactor	and motor, and near controller	motor is longer than 100m, it is recommended to install the AC output reactor.

Selecting of External Device

Type	Vacancy (MCCB) (A)	Contactor (A)	Input side main circuit lead (mm ²)	Output side main circuit lead (mm ²)	Control circuit lead (mm ²)	Grounding (mm ²)
NICE-L-A/B-2002	20	16	4	4	1	4
NICE-L-A/B-2003	32	25	6	4	1	4
NICE-L-A/B-4002	16	10	4	4	1	4
NICE-L-A/B-4003	25	16	4	4	1	4
NICE-L-A/B-4005	32	25	4	4	1	4
NICE-L-A/B-4007	40	32	6	6	1	4
NICE-L-A/B-4011	63	40	6	6	1	4
NICE-L-A/B-4015	63	40	6	6	1	4
NICE-L-A/B-4018	100	63	10	10	1	4
NICE-L-A/B-4022	100	63	10	10	1	4
NICE-L-A/B-4030	125	100	16	16	1	4
NICE-L-A/B-4037	160	100	16	16	1	4
NICE-L-A/B-4045	200	125	25	25	1	4

DBR

The following types of NICE 3000 integrated controller have been equipped with brake unit inside with power no more than 30KW. User just needs to externally connect brake resistance. For those types above 30KW, it needs brake unit and brake resistance.

Type	Configure of brake resistance	Brake unit
MCTC- DBR-4001	300W ,200Ω	Standard equipment
MCTC- DBR-4002	600W ,220Ω	
MCTC- DBR-4003	1100W ,130Ω	
MCTC- DBR-4005	1600W ,90Ω	
MCTC- DBR-4007	2500W ,65Ω	
MCTC- DBR-4011	3500W ,43Ω	
MCTC- DBR-4015	4500W ,32Ω	
MCTC- DBR-4018	5500W ,25Ω	
MCTC- DBR-4022	6500W ,22Ω	
MCTC- DBR-4030	9000W ,16Ω	
MCTC- DBR-4037	11000W ,13Ω	External equipment
MCTC- DBR-4045	13500W ,10Ω	
MCTC- DBR-4055	16500W ,9Ω	

3.3.2 Electric wiring

Electric wiring include three parts: controller main circuit, main control board wiring and encoder wiring.

- 1) Main circuit connection and terminal function
 - a) main circuit:

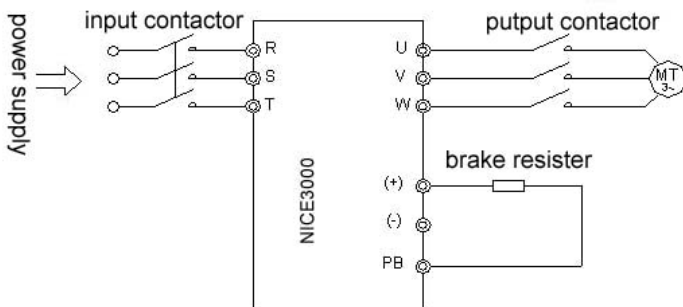

Chart 3-3 Main Circuit Wiring

b) terminal function:

Terminal	Name	Instruction
R、S、T	3-phase power input terminal	Connect 3-phase AC380V
(+)、(-)	Positive and negative terminals of DC bus	Shared DC bus input, for controller above 37kW, they are for brake unit
P(+)、PB	Terminals for brake resistor	For controller below 30kW(include 30kW) they are for brake unit
U、V、W	controller output terminal	Connect 3-phase motor
PE	Terminal for grounding	Grounding terminal

Note:

- ☆ Select the recommended resistor according to selection form of brake resistance's type.
- ☆ Controller output circuit grounding or short circuit is absolutely not permitted.
- ☆ Controller output cables of U, V and W should be in metal pipe with grounding, and divided or vertical with control circuit cables.

☆ If the cables between the motor and the controller are too long, electrical resonance may occur due to the distributed capacitance, which may result in damaging the motor insulation or big leakage current that will make the controller go into protective status.

☆ Grounding terminal must be connected to earth reliably, the grounding cable should be thick and short, the recommended grounding cable should be special yellow-green cable above 4 mm² with several copper cores. And the grounding resistance shall be less than 4Ω. Do not share the PE and neutral line of the main supply.

2) MCTC-MCB-A main control board wiring instruction

a) MCTC-MCB-A main control panel installation location:

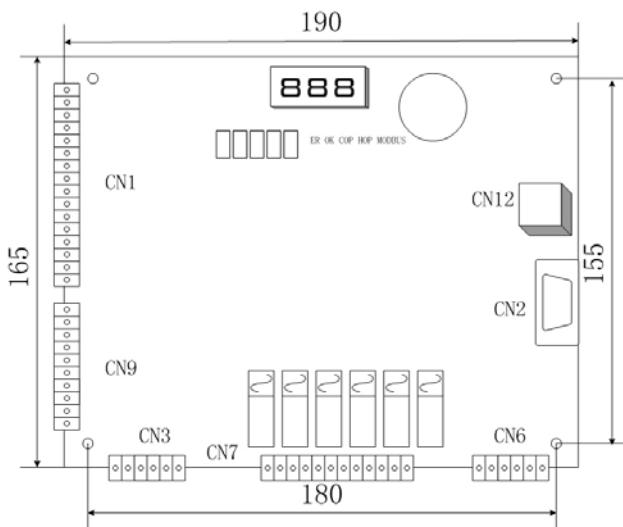

Chart 3-4 MCTC-MCB-A Main Control Panel Dimension

b) indicator light instruction of MCB:

Terminal	Name	Instruction
ER	Error indicator	when error, ER indicator lighten (red)
OK	OK indicator	when no error, OK indicator lighten (green)
COP	CTB communication indicator	when communication well between MCB and CTB, COP indicator lighten (green)
HOP	Hall call indicator	when communication well between MCB and HCB, HOP indicator lighten (green)
X1~X24	Input signal indicator	when external input, indicator lighten (green)
Y1~Y6	Output signal indicator	when signal output, indicator lighten (green)

c) terminal list:

C N 1	X1	C N 9	X17	C N 3	24V	C N 7	Y1
	X2		X18		COM		M1
	X3		X19		MOD		Y2
	X4		X20		+		M2
	X5		X21		MOD-		Y3
	X6		X22	CAN+	M3		
	X7		X23	CAN-	Y4		
	X8		X24		M4		
	X9		M	C N 6	15V	Y5	
	X10	AI	PGM		M5		
	X11		PGA		Y6		
	X12		PGB		M6		
	X13		PGM				
	X14		PE				
	X15						
	X16						

Chart 3-5 MCTC-MCB-A Terminal Definition

d) Plug CN1 and CN9 instruction:

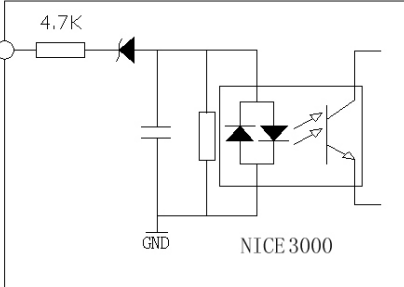
Terminal	Name	Instruction
X1~X24	digital signal input function selection	1. photocoupler isolation input 2. input resistance : 4.7K Ω 3. input voltage range: 10~30V 4. input current limit :5mA 
Ai	simulate input terminal	terminal for simulation input,-10~10V,for weighing device
M	DC 0V power	

e) Plug CN3 instruction:

Terminal	Name	Instruction
24V	External DC24V input	Provide MCTC-MCB-A with DC24V, for input, output circuit and communication circuit
COM		
MOD+	Modbus communication terminal	Display control board Seriall communication signal feedback. STP recommended.
MOD-	Modbus communication terminal	

Terminal	Name	Instruction
CAN+	CAN bus communication terminal	Used for CAN communication between MCTC-MCB-A and MCTC-CTB-A. STP recommended.
CAN-	CAN bus communication terminal	

f) Plug CN7 instruction:

Terminal	Name	Instruction
Y1~M1 Y2~M2 Y3~M3 Y4~M4 Y5~M5 Y6~M6	relay output function selection	The relay normal open contact outputs 5A, 250VAC, and corresponding function code is decided by F5-26 ~F5-31.

g) Plug CN6 encoder interface terminal instruction:

Terminal	Name	Instruction
15V	DC15V output	Provide DC15V for encoder, suit for incremental push-pull output or incremental plough collector output.
PGM		
PGA	coding pulse input A phase	Incremental coding pulse signal inputting, frequency dividing signal input A phase and B phase in IP motor, Type MCTC-PG-B. The system will show the fault of encoder if A phase and B phase are wrongly connected.
PGB	coding pulse input B phase	

Terminal	Name	Instruction
PGM	DC15 0V terminal	MCTC-PG-B grounding terminal
PE	Grounding terminal	Encoder wire shield layer

And CN12 is interface for operation panel, CN2 is interface for computer monitor.

h) jumper J5、J6 instruction (Except for VER A, VER B, VER C)

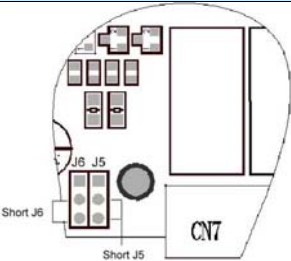
Terminal	Name	Instruction
JP5	CAN communication matching resistance jumper	 <p>Short J5, inner calling communication circuit will be connected with internal resistance. Short J6, outer calling communication circuit will be connected with internal resistance.</p>
J6	Outer calling matching resistance jumper	

3) MCTC-MCB-B main control board electric wiring instruction

MCTC-MCB-B has all the function of MCTC-MCB-A and changes on the hardware's structure. Meanwhile it adds one slot J12 with 28 holes to match the use of PG card PG-D and PG-E. The specific instruction will be introduced in PG-D and PG-E.

a) Main control board installation size:

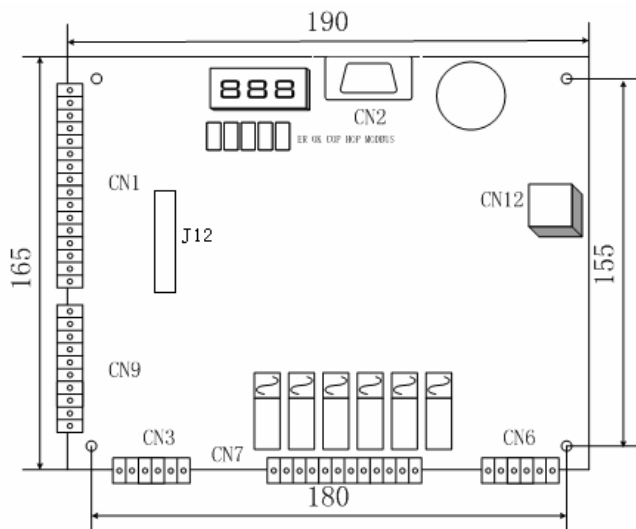

Chart 3-6 Main control board installation size of MCTC-MCB-B

- b) The main control board's indicator, terminal interface, and use of MCTC-MCB-B is the same with that of MCTC-MCB-A and can refer to the instruction book of MCTC-MCB-A.

MCTC-MCB-B is the advanced product of MCTC-MCB-A and will replace it.

4) Encoder wiring

- a) Following items should be noticed in encoder wiring:

- PG wire should be laid separately and keep distance from control circuit and driver circuit and forbidden to parallel with them.
- PG wire should be shield wire, and shield layer should connect to PE near controller. (In order to avoid being disturbed, only one terminal connects to ground.)

- PG wire should be pulled on pipe separately, and metal crust should be connected to ground credibility.

b) Encoder connection as follows:

Encoder connection of increment push-pull output and plough collector output.

MCTC-MCB-A/B self-equipped with push-pull encoder trans-connection circuit.

Its connection is as follows:

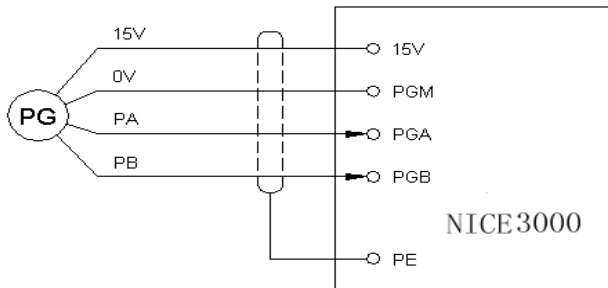

Chart 3-7 connection of increment push-pull output and plough collector output encoder

c) Type U, V, W encoder wiring

For type UVW encoder, the controller of the main control board with the type MCTC-MCB-A needs to equip with PG connection card MCTC-PG-B; the controller of the main control board with the type MCTC-MCB-B needs to equip with PG connection card MCTC-PG-B and needs to equip with MCTC-PG-D through the slot J12 on the main control board.

- Terminal instruction of MCTC-PG-B card

There are 15 user connection terminals and 16 pin interfaces with two lines, referring to chart3-8. VCC and GND supply the encoder with work power; A+, A-, B+, B-, U+, U-, V+, V-, W+, W- are encoder's signal inputting terminal;

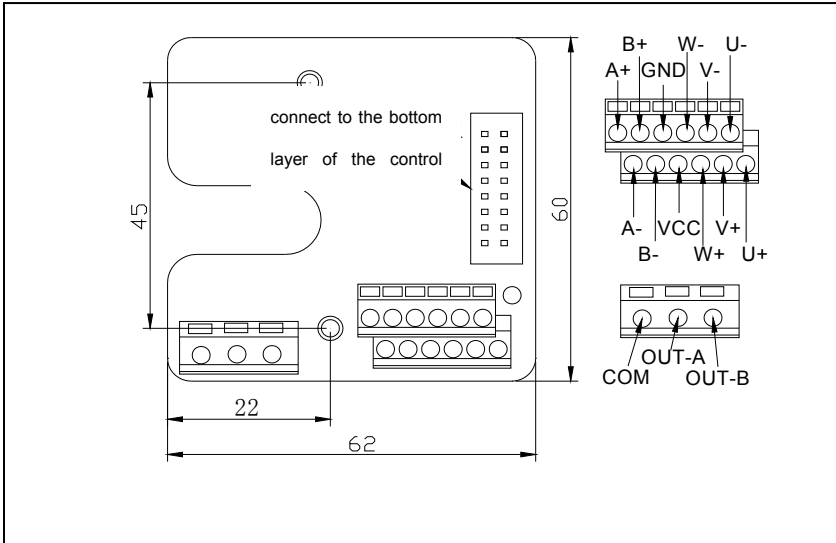

COM, OUT-A, OUT-B are frequency division signal outputting terminals; 16 pin interfaces connect to the bottom drive board of the controller.

Chart 3-8 MCTC-PG-B sketch

- MCTC-PG-B technique data

	Function	Responding speed	Output impedance	Output current	Frequency division range
VCC, GND	Encoder power supply	---	About 300Ω	300mA	---
A+, B+, A-, B-, U+, V+, W+, U-, V-, W-	Encoder signal input	0~80 kHz	---	---	---
OUT-A, OUT-B, COM	Frequency division output	0~80 kHz	About 300Ω	100mA	1

- The wiring of MCTC-PG-B and UVW encoder is shown as follows:

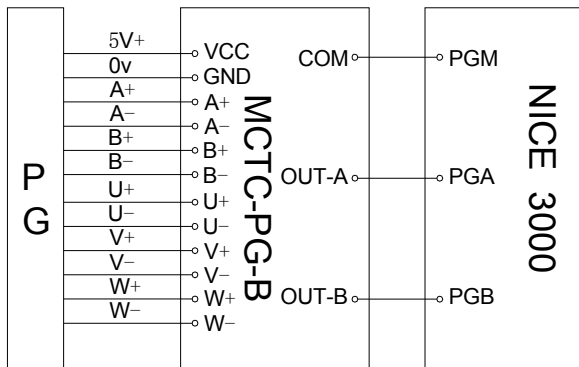

Chart 3-9 MCTC-PG-B wiring

- MCTC-PG-E appearance and installation

MCTC-PG-E is installed on the main control board through J1 (Two lines of 28 plugs), and connected with SIN/COS encoder through CN1 interface. The appearance and installation size are in the following chart3-13:

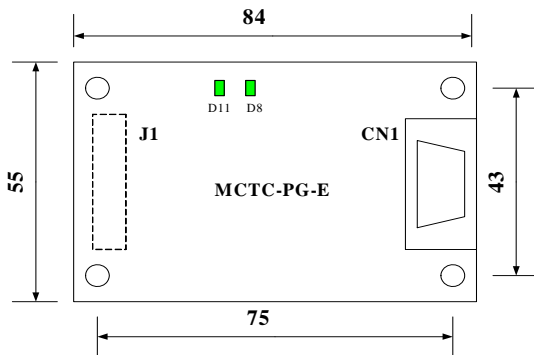
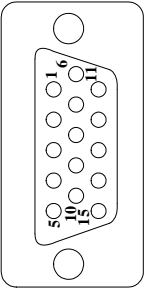

Chart 3-13 MCTC-PG-E appearance and size

- MCTC-PG-E wiring instruction

The CN1 terminal of MCTC-PG-E is connected with SIN/COS encoder with Type D 15 pins (DB15) connector. The meaning of each pin of the connector is as follows:

Type of PG trans-connection card	The meaning of DB15's each pin		Suitable encoder
MCTC-PG-E		1: B- 2: NC 3: Z+ 4: Z- 5: A+ 6: A- 7: COM 8: B+ 9: VCC 10: C+ 11: C- 12: D+ 13: D- 14: NC 15: NC	SIN/COS encoder

- Instruction of MCTC-PG-E indicator:

Type of PG trans-connection card	Number	Function description
MCTC-PG-E	D8	B+/B-Differential signal indicator, flash while running
	D11	A+/A-Differential signal indicator, flash while running



4

Instruction of debugging tools

Chapter 4 Instruction of adjusting tools

4.1 Sort of adjusting tools for NICE 3000

Adjusting tools of NICE3000 include four kinds: operation control and information display panel (operation panel for short), small keyboard on MCB, upper monitor motoring software of NICE 3000, and PDA monitoring software. This chapter will give the instruction focusing on Operation Panel and Small Keyboard in common use.

4.2 Operation Panel Instruction

Through operation panel, user can modify the parameter, monitor the working state, and control running (start and stop) when operation panel is working.

4.2.1 The Appearance and Function Section of Operation Panel

The appearance as Chart 4-1:

- 1) Instruction of function indicator lights:

RUN LED on indicates the controller is working.

LOCAL/REMOT Reserved.

FWD/REV Indicator of up and down. LED on indicates the elevator goes down; LED off, up.

TUNE/TC Indicator of tuning. LED on, tuning.

- 2) Digital display area:

5-bit LED display, show the parameters of move speed, bus voltage, etc.

- 3) Units indicator instruction:



Chart4.1 operation panel

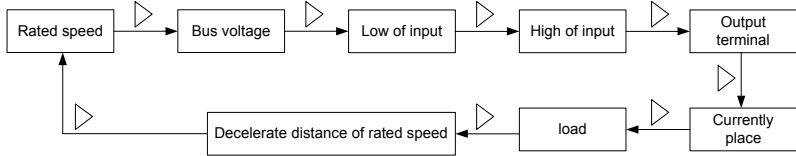

Chart 4-4 Example of Parameter Changing in Stopping State

In stopping and running status, the LED can display several status parameters, Whether to display the status parameters is dependent on the bit setting of FA-01 (running parameter) and FA-02 (stopping parameter). Through key **>>**, user can shift the display in sequence and display the stopping or running status parameters circularly.

In stopping state, there are 12 status parameters for NICE3000, user can shift to display the parameters circularly by key **>>**. The parameters are: rated speed, bus voltage, low bit of input terminal, high bit of input terminal, output terminal, currently floor, currently place, car load, decelerate distance of rated speed, car top input state, car top output state and system state. Users can select the desired parameters through the bit of FA-02.

In running state, there are 16 state parameters for NICE3000. Users can shift to display the parameters circularly by key **>>**. The parameters are: running speed, rated speed, bus voltage, output voltage, output current, output frequency, low bit of input terminal, high bit of input terminal, output terminal, currently floor, currently place, car load, input of CTB-A, output of CTB-A, system state, and advance torque current. Users can select the desired parameters through the bit of FA-01.

3) Error information reading

When error occurs in the controller, the error information will be displayed on the panel. It is convenient to find reasons for the error and get rid of the error as soon as possible.

The controller can save the last 11 error codes. Users can read the first error code in the following way:

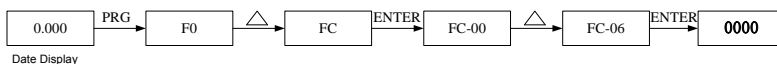

Chart 4-5 way of error information reading

4.2.3 Operation Instruction of Quick Menu

Quick menu of NICE3000 is created for the purpose of making it convenient for users to check and modify the frequently used parameters. The parameter display mode in quick menu is “uF3.02”, which means changing the parameter in quick menu is the same with that in common programming status.

Up to 16 parameters can be saved in quick menu. If 16 parameters are stored and more are wanted, the “FULL” will be displayed; if entering the menu and the “NULL” is displayed, which means no parameter is stored in the quick menu.

There are 16 parameters stored in advance in NICE 3000:

F0-03:	Maximum running speed	F5-36:	Input way of weighing
F0-04:	Rated speed	F6-00:	Top floor
F0-05:	Rated load	F6-02:	Parking floor
F1-12:	Encoder pulse number per rotation	F8-01:	Advance torque selection
F3-00:	Start-up speed	F8-02:	Advance torque offset
F3-01:	Time keeping	F8-03:	Drive gain
F3-10:	Re-leveling speed	F8-04:	Brake gain
F4-00:	Leveling adjusting	FC-22:	Latest error type

Users can modify it according to needs.

- 1) Add parameters in the quick menu:

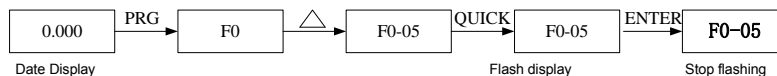

Chart 4-6 Add parameters in the quick menu

In the 2nd level menu, press QUICK to enter the quick menu. The flashing indicates whether to save the parameter into the quick menu. When it stops

flashing, the operation is completed; Press PRG to cancel, then it stops flashing, and the operation is cancelled.

2) Parameters out and modifying in the quick menu

Select out and modify parameters F0-03, F3-10, F5-36, F8-11 from the quick menu.

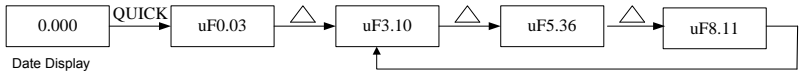

Chart 4-7 Change the parameter in the quick menu

In stopping or running display interface, press QUICK to enter quick menu, and press UP/DOWN to select different parameters, then press ENTER to enter the next level menu. The changing method is the same with that in the third level menu. Press QUICK to back to last screen and the changed parameter will not be saved.

3) Delete the parameter in the quick menu:

If there are parameters as F0-03, F3-10, F5-36, and F8-11 in the quick menu, and you want to delete F5-36, please operate as follows:

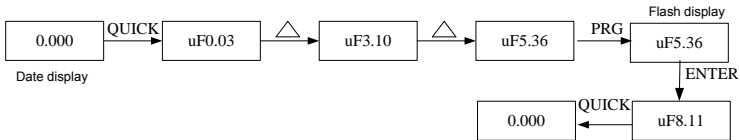

Chart 4-8 Delete the parameter in the quick menu

Press PRG in the quick menu, the displayed parameter flashes, and prompt the user whether to delete the parameter in the menu. Pressing ENTER will delete the parameter in the menu and the displayed parameter stops flashing, while pressing QUICK will cancel the deleting operation and the displayed parameter stops flashing, and the operation is completed. If the last parameter is deleted, and "NULL" will be displayed, that means no parameter is stored in the menu.

4.2.4 Password Setting

In order to protect the parameter more effectively, the controller provides the password protection.

The figures below show how to change the password to 12345 (bold shows flashing bit):

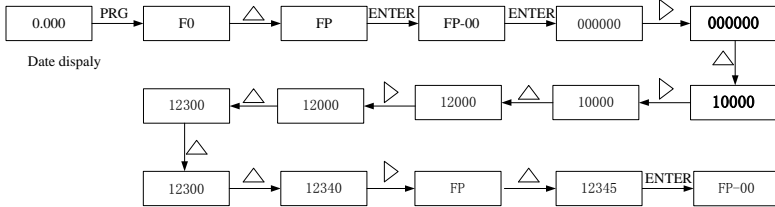

Chart 4-9 Password setting procedure

When the user has set the password (the password parameter of FP-00 shouldn't be ZERO), the password protection function is valid once the user presses PRG, and the controller shall display“-----”. The user can only enter the menu after inputting the user password. Otherwise, the user cannot enter. For factory setting parameters editing, the user still need to input the factory password. (Warning: do not change the factory setting parameter; if the parameter values are wrong, the controller will work abnormally, even be damaged.)

When the password protection is unlocked, user can change the password freely, and the last input number will be the user password.

If the user wants to cancel the password protection function, enter after inputting the password and set FP-00 as 0; when the power is on, the parameter will be protected by the password if FP-00 isn't set ZERO.

4.3 Function and Use Instruction of Small Keyboard

Small keyboard is consisted of three numeral lamp and three keys, and it takes charge of displaying the information of main board MCB and receiving the simple order inputted. The menu is divided into function F0~F8.

4.3.1 Appearance of Small Keyboard

Appearance is as follows:

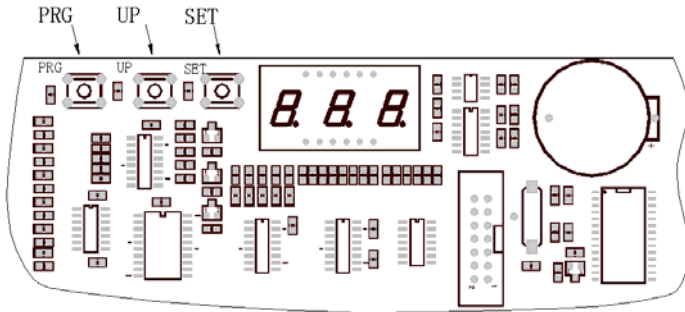

Chart 4-10

4.3.2 Function Instruction of Small Keyboard

3 keys are defined as PRG、UP、SET, and marked beside.

- 1) PRG: In any state, press PRG, the function code will be displayed and it can be changed by pressing UP;
- 2) UP: In function group menu, pressing UP can change function code circularly, as 0, 1, 2, 3, 4, 5, 6, 7, 0... There are 8 function codes defined in MCB controller at present. Additional, in special function group, UP also could be used for inputting the order;
- 3) SET: In function group, press SET and it will enter this menu. In special function group, after inputting simple order and pressing SET, it will save and enter F0 automatically.

In the adjusting state, press PRG first, then select the function group code with UP. It displays as 0,1,2,3,4,5,6,7,0,1,2...then press SET to enter the state. If you press three buttons at the same time or either two of them, the operation is not valid.

4.3.3 Function Code of Small Keyboard

Code	Date menu content
F 0	Floor and run direction information
F 1	Input of floor running order
F2	Error reset
F 3	Time display
F 4	Contract number

F 5	Run times display
F 6	reserved (forbid user setting, dangerous!)
F 7	Floor self-tuning order input
F8	Testing function

4.3.4 Function Instruction of Each Menu

F0 (Floor and run direction information): F0 date menu will be display as default after electrify. The first bit of numeral lamp is used for direction; the second and the third bit are used for displaying current floor. When stopping, first lamp doesn't display, and when travel up or down, the first display direction up or down. If error (no error formerly), the numeral lamp automatically switches to display the error code. If error automatically disappears, F0 date menu will be display.

F1 (Input of floor running order): After entering F1 date menu through PRG, UP, SET, the numeral lamp display the lowest floor (the same as F6-01), and you can select floor (lowest to top) by UP, then press SET to save the data. The lift will travel to the aimed floor. The numeral lamp will switch to display F0 date menu after arriving the destination.

F2 (Error reset): After entering F2 date menu through PRG, UP, SET, the numeral lamp display "0". The parameter can be changed through UP, with the range from 0~1. And '1' denotes order of error reset, then press SET to save. The numeral lamp will switch to display F0 date menu.

F3 (Time display): After entering F3 date menu through PRG, UP, SET, the numeral lamps display time circularly. For example: 2005-03-01-08-30.

F4 (Contract number): After entering F3 date menu through PRG, UP, SET, the numeral lamps display the user's contract number.

F5 (Run times display): After entering F3 date menu through PRG, UP, SET, the numeral lamps display run times circularly. For example: "100000", display 999999 times at most..

F6: reserved. (forbid user setting, dangerous!)

F7 (Floor self-tuning order input): After entering F7 date menu through PRG, UP, SET, the numeral lamp display '0'. The parameter can be changed through UP, with the range from 0~1. And '1' denotes order of self-tuning of floor, and then press SET to save. The controller begins

self-tuning. At the same time, the numeral lamp switches to display F0 date menu. After self-tuning of floor, F7 backs to 0 automatically.

F8 (Testing function): After entering F7 date menu through PRG, UP, SET, the numeral lamp display '00'. The range of F8 is from 00~04. Instructions as follows:

00—none;

01—forbid calling outside;

02—forbid opening door

03—allow overload

04—short limit switches

Press SET to affirm after changing the parameter and the numeral flashing 'E88' to show that the lift is in testing state. Press PRG to quit and F8 backs to '0' automatically.

In addition, when small keyboard on main control panel enters F8 group and in test function mode, SET equals to close door button.



Function parameters table

Chapter 5 Function parameters tables

5.1 Function parameters Indication

1. Its function parameters are classified into 17 groups. Each function group

has several function codes. The function code adopts the 3rd level menu in the form of F X-XX. In the manual it means No. XX function code in group X. For example, "F 8-08" means No.8 function code in group F8.

In order to make it convenient for function code setting, when conducting operation via operation panel, the function group number corresponds to the first level menu, the function code number corresponds to the second level menu, and function code parameters correspond to the third level menu.

2. Contents in the function tables:

In column 1, "Function code" means the code for the function parameter group and the parameter; "Name" in column 2 means the complete name of the function parameter; "Setting range" in column 3 means the valid parameter setting range, displaying on the LED indicator of operation panel; "Min. Unit" in column 4 means the minimum unit of the parameter setting; "Default" in column 5 means the original default; "Modification" in column 6 means the modification attributes of the parameters (i.e. whether to enable the modification and the modification requirements) :

'☆': the parameter can be modified while the NICE3000 is running or stopping;

'★': the parameter can not be modified while the NICE3000 is running;

'●': it is actually measured recorded parameter, which cannot be modified;

(The system has already set the modification attributes of the parameters to prevent the user from making wrong modification to the parameter.)

3. "Default" means the numeric value after the function code parameter is

refreshed when recovering the default parameter; but the actual measured value or recorded value will not be refreshed.

4. The controller provides function code with password protection to protect the

parameters more effectively (Detailed in Sector 4.2.4 of Chapter 4).

5.2 Function Parameters Tables

5.2.1 Groups of Function Parameters

Press UP/DOWN button after pressing “PRG”, all the first level menu displayed are the groups of function. Details as follows:

- | | |
|-----------------------------------|--------------------------------------|
| F0——Basic parameters | F9——Time parameters |
| F1——Motor parameters | FA——Keyboard setting parameters |
| F2——Vector control parameters | FB——Door function parameters |
| F3——Running control parameters | FC——Protect function parameters |
| F4——Floor parameters | FD——communication parameters |
| F5——Terminal function parameters | FE——Lift function setting parameters |
| F6——Lift basic parameters | FF——Factory parameters |
| F7——Testing function parameters | FP——User parameters |
| F8——Reinforce function parameters | |

5.2.2 Parameters tables

Function Code	Name	Setting Range	Min. Unit	Default	Modification
F0 Basic Parameters					
F0-00	Control modes	0: Speed sensorless vector control(SVC) 1: Vector control(VC) with speed sensor	1	1	★

Function Code	Name	Setting Range	Min. Unit	Default	Modification
F0-01	Command source selection	0: Operating panel command channel 1: Distance control	1	1	★
F0-02	Operating panel speed	0.050~F0-04	0.001m/s	0.050m/s	☆
F0-03	Elevator Max. running speed	0.250~F0-04	0.001m/s	1.600m/s	★
F0-04	Elevator rated speed	0.250~4.000m/s	0.001m/s	1.600m/s	★
F0-05	Lift rated load	300~9999 kg	1 kg	1000 kg	★
F0-06	Max. frequency	20.00Hz~99.00Hz	0.01Hz	50.00Hz	★
F0-07	Carrier frequency	0.5~16.0kHz	0.1kHz	6kHz	☆
F1 Motor Parameters					
F1-00	Encoder type selection	0: SIN/COS increment (ERN 1387) 1: UVW increment	1	1	★
F1-01	Rated power	1.1~75.0kW	0.1kW	Depending on the model	★
F1-02	Rated voltage	0~440V	1V	380V	★
F1-03	Rated current	0.00~655.00A	0.01A	Depending on the model	★
F1-04	Rated frequency	0.00~99.00Hz	0.01Hz	50.00Hz	★
F1-05	Rated rotation speed	0~3000rpm	1 rpm	1460 rpm	★
F1-06	Stator resistance (Asynchronous motor) Encoder original angle(Synchronous motor)	0.000~30.000Ω 0~359.9°	0.001Ω 0. 1°	Depending on the model	☆
F1-07	Rotor resistance Power-removal angle (sync)	0.000~30.000Ω 0-359.9	0.001Ω 0.1	Depending on the model	☆

Function Code	Name	Setting Range	Min. Unit	Default	Modification
F1-08	Leakage inductance (Asynchronous motor) Wire connection (Synchronous motor)	0.00~300.00mH 0~15	0.01mH 0.01	Depending on the model	☆
F1-09	Mutual inductance ADC sampling delay function(sync)	0.1~3000.0mH 0.00-40.00	0.1mH 0.00	Depending on the model	☆
F1-10	No-load current Encoder test selection(sync motor)	0.01~300.00A 0~31	0.01A 01	Depending on the model	☆
F1-11	Self-tuning selection	0: No operation 1: motor tuning with load 2: motor tuning without load 3: shaft self-tuning	1	0	★
F1-12	Encoder pulse number per rotation	0~10000	1	1024	★
F1-13	Encode failure monitoring times	0.0~10.0s Less than 1s, monitoring function not valid	0.1s	2.1s	★
F2 Vector Control Parameters					
F2-00	Proportional gain 1 of speed loop	0~100	1	40	☆
F2-01	Integration time 1 of speed loop	0.01~10.00s	0.01S	0.60S	☆
F2-02	Switching frequency 1	0.00~F2-05	0.01Hz	2.00Hz	☆
F2-03	Proportional gain 2 of speed	0~100	1	35	☆

Function Code	Name	Setting Range	Min. Unit	Default	Modification
	loop				
F2-04	Integration time 2 of speed loop	0.01~10.00s	0.01s	0.80s	☆
F2-05	Switching frequency 2	F2-02~F0-06	0.01Hz	5.00Hz	☆
F2-06	Proportional gain of current loop	10~500	1	60	☆
F2-07	Integral gain of current loop	10~500	1	30	☆
F2-08	Upper limit of torque	0.0~200.0%	0.1%	150.0%	☆
F2-10	Lift Running direction	0:same direction 1:reverse running direction, reverse position impulse direction 2:same running direction, reverse impulse direction 3:reverse running direction, same impulse direction	1	0	☆
F3 Running Control Parameters					
F3-00	Start speed	0.000~0.030m/s	0.001m/s	0.010m/s	★
F3-01	Time keeping	0.000~0.500s	0.001s	0.150s	★
F3-02	Acceleration	0.200~2.000m/s ²	0.001m/s ²	0.600m/s ²	★
F3-03	Inflexion speedup time 1	0.300~4.000s	0.001s	2.500s	★
F3-04	Inflexion speedup time 2	0.300~4.000s	0.001s	2.500s	★
F3-05	Deceleration	0.200~2.000m/s ²	0.001m/s ²	0.600m/s ²	★
F3-06	Inflexion slow-down time 1	0.300~4.000s	0.001s	2.500s	★
F3-07	Inflexion slow-down time 2	0.300~4.000s	0.001s	2.500s	★
F3-08	Special	0.500~2.000m/s ²	0.001m/s ²	0.900m/s ²	★

Function Code	Name	Setting Range	Min. Unit	Default	Modification
	deceleration				
F3-09	Pre-distance of stop	0~90.0mm	0.1mm	0.0mm	★
F3-10	Re-leveling speed	0.000~0.080 m/s	0.001 m/s	0.040m/s	★
F3-11	Speed of slow running	0.100~0.630 m/s	0.001 m/s	0.250m/s	★
F3-12	Switching position of the NO.1 up force reducer	0.00~300.00m	0.01m	0.00m	★
F3-13	Switching position of the NO.1 down force reducer	0.00~300.00m	0.01m	0.00m	★
F3-14	Switching position of the NO.2 up force reducer	0.00~300.00m	0.01m	0.00m	★
F3-15	Switching position of the NO.2 down force reducer	0.00~300.00m	0.01m	0.00m	★
F3-16	Switching position of the NO.3 up force reducer	0.00~300.00m	0.01m	0.00m	★
F3-17	Switching position of the NO.3 down force reducer	0.00~300.00m	0.01m	0.00m	★
F3-18	Output time of starting zero speed	0.000~1.000s	0.001s	0.200s	★
F3-19	Time-lag of curve running	0.000~1.000s	0.001s	0.200s	★

Function Code	Name	Setting Range	Min. Unit	Default	Modification
F3-20	Time-lag of end running	0.000~1.000s	0.001s	0.300s	★
F4 Floor Position Parameters					
F4-00	Leveling adjusting	0~60mm	1mm	30mm	★
F4-01	Current floor	F6-01~F6-00	1	1	★
F4-02	High bit of current floor	0~65535	1	1	●
F4-03	Low bit of current floor	0~65535	1	34464	●
F4-04	High bit of leveling plate	0~65535	1	0	★
F4-05	Low bit of leveling plate	0~65535	1	0	★
F4-06	High bit of floor high 1	0~65535	1	0	★
F4-07	Low bit of floor high 1	0~65535	1	0	★
F4-08	High bit of floor high 2	0~65535	1	0	★
F4-09	Low bit of floor high 2	0~65535	1	0	★
F4-10	High bit of floor high 3	0~65535	1	0	★
F4-11	Low bit of floor high 3	0~65535	1	0	★
F4-12	High bit of floor high 4	0~65535	1	0	★
F4-13	Low bit of floor high 4	0~65535	1	0	★
F4-14	High bit of floor high 5	0~65535	1	0	★
F4-15	Low bit of floor high 5	0~65535	1	0	★
F4-16	High bit of floor high 6	0~65535	1	0	★

Function Code	Name	Setting Range	Min. Unit	Default	Modification
F4-17	Low bit of floor high 6	0~65535	1	0	★
F4-18	High bit of floor high 7	0~65535	1	0	★
F4-19	Low bit of floor high 7	0~65535	1	0	★
F4-20	High bit of floor high 8	0~65535	1	0	★
F4-21	Low bit of floor high 8	0~65535	1	0	★
F4-22	High bit of floor high 9	0~65535	1	0	★
F4-23	Low bit of floor high 9	0~65535	1	0	★
F4-24	High bit of floor high 10	0~65535	1	0	★
F4-25	Low bit of floor high 10	0~65535	1	0	★
F4-26	High bit of floor high 11	0~65535	1	0	★
F4-27	Low bit of floor high 11	0~65535	1	0	★
F4-28	High bit of floor high 12	0~65535	1	0	★
F4-29	Low bit of floor high 12	0~65535	1	0	★
F4-30	High bit of floor high 13	0~65535	1	0	★
F4-31	Low bit of floor high 13	0~65535	1	0	★
F4-32	High bit of floor high 14	0~65535	1	0	★
F4-33	Low bit of floor high 14	0~65535	1	0	★
F4-34	High bit of floor high 15	0~65535	1	0	★

Function Code	Name	Setting Range	Min. Unit	Default	Modification
F4-35	Low bit of floor high 15	0~65535	1	0	★
F4-36	High bit of floor high 16	0~65535	1	0	★
F4-37	Low bit of floor high 16	0~65535	1	0	★
F4-38	High bit of floor high 17	0~65535	1	0	★
F4-39	Low bit of floor high 17	0~65535	1	0	★
F4-40	High bit of floor high 18	0~65535	1	0	★
F4-41	Low bit of floor high18	0~65535	1	0	★
F4-42	High bit of floor high 19	0~65535	1	0	★
F4-43	Low bit of floor high 19	0~65535	1	0	★
F4-44	High bit of floor high 20	0~65535	1	0	★
F4-45	Low bit of floor high 20	0~65535	1	0	★
F4-46	High bit of floor high 21	0~65535	1	0	★
F4-47	Low bit of floor high 21	0~65535	1	0	★
F4-48	High bit of floor high 22	0~65535	1	0	★
F4-49	Low bit of floor high 22	0~65535	1	0	★
F4-50	High bit of floor high 23	0~65535	1	0	★
F4-51	Low bit of floor high 23	0~65535	1	0	★
F4-52	High bit of floor high 24	0~65535	1	0	★

Function Code	Name	Setting Range	Min. Unit	Default	Modification
F4-53	Low bit of floor high 24	0~65535	1	0	★
F4-54	High bit of floor high 25	0~65535	1	0	★
F4-55	Low bit of floor high 25	0~65535	1	0	★
F4-56	High bit of floor high 26	0~65535	1	0	★
F4-57	Low bit of floor high 26	0~65535	1	0	★
F4-58	High bit of floor high 27	0~65535	1	0	★
F4-59	Low bit of floor high 27	0~65535	1	0	★
F4-60	High bit of floor high 28	0~65535	1	0	★
F4-61	Low bit of floor high 28	0~65535	1	0	★
F4-62	High bit of floor high 29	0~65535	1	0	★
F4-63	Low bit of floor high 29	0~65535	1	0	★
F4-64	High bit of floor high 30	0~65535	1	0	★
F4-65	Low bit of floor high 30	0~65535	1	0	★
F4-66	reserved	0~65535	1	0	*
F4-67	reserved	0~65535	1	0	*
F5 Terminal Function Parameters					
F5-00	ATT/Normal switching time	3~200s	1	3s	★

Function Code	Name	Setting Range	Min. Unit	Default	Modification
F5-01	Select function of terminal X1	00: No function 01: N.O. input of up leveling 02: N.O. input of down leveling 03: N.O. input of door zone	1	33	★
F5-02	Select function of terminal X2	04: N.O. input of Safety circuit feedback	1	35	★
F5-03	Select function of terminal X3	05: N.O. input of Lock circuit feedback	1	34	★
F5-04	Select function of terminal X4	06 : N.O. input of running output feedback	1	04	★
F5-05	Select function of terminal X5	07: N.O. input of brake output feedback signal	1	05	★
F5-06	Select function of terminal X6	08: N.O. input of inspection signal	1	38	★
F5-07	Select function of terminal X7	09: N.O. input of inspection up 10: N.O. input of inspection down	1	39	★
F5-08	Select function of terminal X8	11: N.O. input of fire signal	1	22	★
F5-09	Select function of terminal X9	12: N.O. input of upper limit signal	1	40	★
F5-10	Select function of terminal X10	13: N.O. input of lower limit signal	1	09	★
F5-11	Select function of terminal X11	14: N.O. input of over loading 15: N.O. input of full load	1	10	★
F5-12	Select function of terminal X12	16: N.O. input of NO.1 up force reducer	1	44	★
F5-13	Select function of terminal X13	17: N.O. input of NO. 1 down force reducer	1	45	★
F5-14	Select function of terminal X14	18: N.O. input of NO.2 up force reducer	1	48	★
F5-15	Select function of terminal X15	19: N.O. input of NO. 2 down force reducer	1	49	★
F5-16	Select function of terminal X16	20: N.O. input of NO.3 up force reducer	1	50	★
F5-17	Select function of terminal X17	21: N.O. input of NO. 3 down force reducer	1	51	★

Function Code	Name	Setting Range	Min. Unit	Default	Modification
F5-18	Select function of terminal X18	22: N.O. input of lock output feedback	1	00	★
F5-19	Select function of terminal X19	23: N.O. input of firemen opening and closing	1	00	★
F5-20	Select function of terminal X20	24: N.O. input of door motor light-beam curtain1	1	00	★
F5-21	Select function of terminal X21	25: N.O. input of door motor light-beam curtain2	1	00	★
F5-22	Select function of terminal X22	26: N.O. input of brake output feedback 2	1	00	★

Function Code	Name	Setting Range	Min. Unit	Default	Modification
F5-23	Select function of terminal X23	27: Valid N.O. input of UPS 28: N.O. input of lift-locking 29 : N.O. input 2 of safety signal 30 : N.O. input of synchronous motor self-locking feedback 31 : N.O. input of door lock circuit2 feedback 33: N.C. input of up leveling 34: N.C. input of down leveling 35: N.C. input of door zone 36: N.C. input of Safety circuit feedback 37: N.C. input of Lock circuit feedback 38 : N.C. input of running output feedback 39 : N.C. input of brake contactor feedback signal 40: N.C. input of inspection signal 41: N.C. input of inspection up 42: N.C. input of inspection down 43: N.C. input of fire signal 44: N.C. input of upper limit signal 45: N.C. input of lower limit signal 46: N.C. input of over loading 47: N.C. input of full loading	1	00	★
F5-24	Select function of terminal X24	48: N.C. input of NO.1 up force reducer 49: N.C. input of NO. 1 down force reducer 50: N.C. input of NO.2 up force reducer	1	00	★

Function Code	Name	Setting Range	Min. Unit	Default	Modification
		51: N.C. input of NO. 2 down force reducer 52: N.C. input of NO.3 up force reducer 53: N.C. input of NO. 3 down force reducer 54: N.C. input of lock output feedback 55: N.C. input of firemen opening and closing 56: N.C. input of door motor light-beam curtain1 57: N.C. input of door motor light-beam curtain2 58: N.C. input of brake output feedback2 59: Valid N.C. input of UPS 60 : N.C. input of lift-locking signal 61 : N.C. input 2 of safety signal 62 : N.C. input of synchronous motor self-locking feedback 63 : N.C. input of door lock circuit 2 feedback			
F5-25	Car top board input type selection	0~255	1	64	★
F5-26	Select function of terminal Y1	0: No function	1	1	★
F5-27	Select function of terminal Y2	1: Run contactor output 2: Brake contactor output	1	2	★
F5-28	Select function of terminal Y3	3: Lock contactor output 4 : Fire arrival land signal feedback	1	3	★
F5-29	Select function of terminal Y4	5: Door motor 1 open 6: Door motor 1 close	1	4	★

Function Code	Name	Setting Range	Min. Unit	Default	Modification
F5-30	Select function of terminal Y5	7: Door motor 2 open. 8: Door motor 2 close	1	0	★
F5-31	Select function of terminal Y6	9: Brake, run contactor normal 10: Failure state 11: Run monitor 12 : Synchronous motor self-locking output 13: Power failure emergency running switching automatically 14: System normal 15: Emergency buzzer output 16: Brake forced output 17: elevator up running mark 18: illustration and fan output	1	0	★
F5-32	Communication state display	Bit 0-bit11 hall call communication state Bit12-bit15 inside call communication state			•
F5-34	Terminal state display				•
F5-36	Weighing input selection	0: car top panel input and analogue input is invalid 1: Car top panel switch input 2: Car top panel analog input 3: Main control panel analog sampling.	1	2	★
F6 Lift Basic Parameters					
F6-00	The highest landing	F6-01~31	1	9	★
F6-01	The lowest landing	1~F6-00	1	1	★
F6-02	Parking main landing	F6-01~ F6-00	1	1	★
F6-03	Fire main landing	F6-01~F6-00	1	1	★

Function Code	Name	Setting Range	Min. Unit	Default	Modification
F6-04	Lift lock main landing	F6-01~F6-00	1	1	★
F6-05	service floor 1	0 ~ 65535 (from 1st to 16th floor)	1	65535	★
F6-06	service floor 2	0 ~ 65535 (from 17 th to 31 st floor)	1	65535	★
F6-07	Group control number	1 ~ 8	1	1	★
F6-08	Lift number	1 ~ 8	1	1	★
F6-09	Parallel selection	Bit0:separate stay function Bit1: reserved Bit2:Parallel in monitor contactor	1	0	★
F6-10	Leveling sensor delay time	10~50ms	1	14ms	★
F6-11	Elevator function selection	Bit4: stop 300 ms current bias mode Bit5:synchronous motor startup current detect function Bit7: inspection non-door zone opening is valid Bit8: first power-apply, open for once when it is normal Bit10: reversal-leveling buzzer is not sound Bit13: E53 error auto reset	1	0	★
F6-12	VIP floor	0- highest floor (F6-00)	1	0	★
F6-13	Security floor	F6-01~F6-00	1	1	☆
F6-14	down-collective 1 start time	00.00 ~ 23.59(hr.min.)	00.01	00.00	☆
F6-15	down-collective 1 end time	00.00 ~ 23.59(hr.min.)	00.01	00.00	☆
F6-16	down-collective 2 start time	00.00 ~ 23.59(hr.min.)	00.01	00.00	☆
F6-17	down-collective 2 end time	00.00 ~ 23.59(hr.min.)	00.01	00.00	☆

Function Code	Name	Setting Range	Min. Unit	Default	Modification
F6-18	Time-sharing service 1 start	00.00~23.59(hr.min.)	00.01	00.00	☆
F6-19	Time-sharing service 1 end	00.00~23.59(hr.min.)	00.01	00.00	☆
F6-20	Time-sharing service 1 floor 1	0~65535 (from 1st to 16th floor)	1	65535	☆
F6-21	Time-sharing service 1 floor 2	0~65535 (from 17 th to 31 st floor)	1	65535	☆
F6-22	Time-sharing service 2 start	00.00~23.59(hr.min.)	00.01	00.00	☆
F6-23	Time-sharing service 2 end	00.00~23.59(hr.min.)	00.01	00.00	☆
F6-24	Time-sharing service 2 floor 1	0~65535 (from 1st to 16th floor)	1	65535	☆
F6-25	Time-sharing service 2 floor 2	0~65535 (from 17 th to 31 st floor)	1	65535	☆
F6-26	Parallel fastigium 1 start time	00.00~23.59(hr.min.)	00.01	00.00	☆
F6-27	Parallel fastigium 1 end time	00.00~23.59(hr.min.)	00.01	00.00	☆
F6-28	Parallel fastigium floor 1	F6-01~F6-00	1	1	☆
F6-29	Parallel fastigium 2 start time	00.00~23.59(hr.min.)	00.01	00.00	☆
F6-30	Parallel fastigium 2 end time	00.00~23.59(hr.min.)	00.01	00.00	☆
F6-31	Parallel fastigium floor 2	F6-01~F6-00	1	1	☆
F7 Testing Function Parameters					
F7-00	Test floor 1	0~the highest floor (F6-00)	1	0	☆

Function Code	Name	Setting Range	Min. Unit	Default	Modification
F7-01	Test floor 2	0~the highest floor (F6-00)	1	0	☆
F7-02	Test floor 3	0~the highest floor (F6-00)	1	0	☆
F7-03	Test times at random	0~60000	1	0	☆
F7-04	Landing call enable	0: Landing call allowable; 1: Landing call forbidden	1	0	☆
F7-05	Door open enable	0: Door open allow 1: Door open forbidden	1	0	☆
F7-06	Overload function selection	0: Overload run forbidden 1: Overload run allowable	1	0	☆
F7-07	Limit enable	0: End switch availability; 1: End switch invalidation	1	0	☆
F8 Reinforce Function Parameters					
F8-00	Weighing self-tuning	0~100%	1%	0%	★
F8-01	Pre-torque selection	0: Pre-torque is invalid 1 : weighing pre-torque compensation 2: automatic pre-torque compensation	1	0	★
F8-02	Pre-torque bias, Zero servo current coefficient	0.0~100.0% 0.20%~50.0%	0.1%	50.0% 15.0%	★
F8-03	Drive gain, Zero servo speed loop KP	0.00~2.00 0.00~1.00	0.01	0.60 0.50	★
F8-04	Brake gain Zero servo speed loop TI	0.00~2.00 0.00~2.00	0.01	0.60 0.60	★
F8-05	Car load at present	0~1023	1	0	●
F8-06	Car no load set	0~1023	1	0	★
F8-07	Car full load set	0~1023	1	100	★
F8-08	Anti-nuisance	0: This function is forbidden;	1	0	☆

Function Code	Name	Setting Range	Min. Unit	Default	Modification
	function	1: Allowable (This function can be used with weighing sensor available.)			
F8-09	Power failure emergency rescue speed	0.000~0.100m/s	0.001m/s	0.050m/s	☆
F8-10	Power failure emergency rescue selection	0: no running 1: UPS power running 2: 48V battery power	1	0	☆
F8-11	Stopping torque output delay	0.200~1.500s	0.001	0.200	☆
F9 Time Parameters					
F9-00	Free return main floor time	0~240min	1min	10min	☆
F9-01	Fan and light closed time	0~240min	1min	2min	☆
F9-02	Longest interval time of floor running	0~45s (invalidation under 3s)	1s	45s	★
F9-03	Clock: year	2000~2100	1	Current time	☆
F9-04	Clock: month	1~12	1	Current time	☆
F9-05	Clock: day	1~31	1	Current time	☆
F9-06	Clock: hour	0~23	1	Current time	☆
F9-07	Clock: minute	0~59	1	Current time	☆
F9-09	Accumulative working time	0~65535hr.	1	0	●
F9-11	Run times high bit	0~9999 Note: 1 means actual 10000 run times	1	0	●
F9-12	Run times low bit	0~9999	1	0	●
FA Keyboard Setting Parameters					
FA-00	Small keyboard display selection	0: Reversal display, physics floor 1: Positive display, physics floor	1	0	☆

Function Code	Name	Setting Range	Min. Unit	Default	Modification
		2: Reversal display, external call data 3: Positive display, external call data			
FA-01	Running display selection	1~65535	1	65535	☆
FA-02	Stopping display selection	1~65535	1	65535	☆
FA-03	Pulse wheel encoder currently angle	0.0~360.0°	0.1°	0.0°	●
FA-04	Software edition 1(FK)	0~65535	1	0	●
FA-05	Software edition 2(ZK)	0~65535	1	0	●
FA-06	Software edition 3(DSP)	0~65535	1	0	●
FA-07	Radiator temperature	0~100℃	1℃	0	●
FB Door Function Parameters					
FB-00	door machine number	1~2	1	1	★
FB-02	Door machine1 service floor 1	0~65535(from 1st to 16th floor)	1	65535	☆
FB-03	Door machine1 service floor2	0 ~ 65535(from 17th to 31st floor)	1	65535	☆
FB-04	Door machine2 service floor1	0 ~ 65535(from 1st to 16th floor)only valid when there are two door machines	1	65535	☆
FB-05	Door machine2 service floor2	0 ~ 65535(from 17th to 31st floor) only valid when there are two door machines	1	65535	☆
FB-06	Time protection for opening the door	5~99s	1s	10s	☆
FB-07	Arrival gong output	0~1000ms	1ms	0	☆

Function Code	Name	Setting Range	Min. Unit	Default	Modification
	delayed-time				
FB-08	Time protection for closing the door	5~99s	1s	15s	☆
FB-09	Door open/close times	0~20	1	0	☆
FB-10	Run main landing door state	0: open the door normally 1: waiting for opening the door	1	0	
FB-11	Time keeping for hall call door opening	1~30s	1s	5s	☆
FB-12	Time keeping for internal call door opening	1~30s	1s	3s	☆
FB-13	Time keeping for opening at main landing (main landing is used including Single Lift, Group Control, and Lock Lift)	1~30s	1s	10s	☆
FB-14	Delay time for open keeping	10~1000s	1s	30s	☆
FC Protect Function Parameters					
FC-00	Earth short circuit protection detection after power on	0: Forbidden; 1: Allowable	1	1	★
FC-01	Protection selection	Bit0 : Overload protection selection 0: Forbidden 1: Allowable Bit1 : Output phase-failure selection 0: Phase-failure protection 1:Phase-failure unprotected	1	1	☆

Function Code	Name	Setting Range	Min. Unit	Default	Modification
		Bit3: E053 add door-close arrival judgment 0:no new method 1:old method + old method Bit4: door-closing arrival judge light curtain 0:no re-opening 1:re-open the door Bit5: DSP communication judgment 0:wire broken check 1:no check Bit6: new method for parallel door block 0: use mew method 1: resume to 745 program Bit7:reveling over-speed check 0:check 1:no check			
FC-02	Overload protection coefficient	0.50~10.00	0.01	1.00	☆
FC-03	Overload pre-warning coefficient	50~100%	1%	80%	☆
FC-04	Error self-resetting times	0 : Means that the system forbidden self-resetting function; 0~10	1	0	★
FC-05	Reset interval time	2~20s	1s	5s	★
FC-06	The first error information	0~3199 Note: The first two figures mean the floor's number, and the last two mean the error code. e.g. error 30 occurs in Floor1(the elevator's position is abnormal), the error information displays	1	0	•

Function Code	Name	Setting Range	Min. Unit	Default	Modification
		0130. 0: No error 1: Inverse unit protection 2: Over current accelerated 3: Over current decelerated 4: Over current constant 5: Over voltage accelerated 6: Over voltage decelerated 7: Over voltage constant 8: Controller power fault 9: Under voltage fault 10: Controller overload 11: Motor overload 12: Input side phase loss 13: Output side phase loss 14: Module overheated 15: Reserved 16: Reserved 17: Contactor fault 18: Current detection fault 19: Motor tuning fault 20: Encoder fault 21: Synchronous motor encoder wiring error 22: Leveling inductor signal is abnormal 23: Short circuit fault to ground 24: Reserved 25: Data storage error 26~28: Reserved 29: Synchronous self-locking contactor feedback is deviant 30: Lift position is deviant 31: DPRAM is deviant 32: CPU is deviant 33: Lift over speed error 34: Logic fault			

Function Code	Name	Setting Range	Min. Unit	Default	Modification
		35: Well self-tuning date is deviant 36: Contact feedback is deviant 37: Brake feedback is deviant 38: Controller encode signal is deviant 39: Motor overheated 40: Lift running condition is not satisfied 41: Safety circuit cut 42: Door lock cut when running 43: Upper limit signal cut when running 44: Lower limit signal cut when running 45: Up/Down force reducer switch cut 46: Re-leveling is deviant 47: Lock contactor is deviant 48: Door open fault 49: Door close fault 50: Group control communication fault 51: Inside call communication fault 52: Outside call communication fault 53: Lock jump fault			
FC-07	The first error month and day	0~1231	1	0	•
FC-08	The second error information	0~3199	1	0	•
FC-09	The second error month and day	0~1231	1	0	•
FC-10	The third error information	0~3199	1	0	•

Function Code	Name	Setting Range	Min. Unit	Default	Modification
FC-11	The third error month and day	0~1231	1	0	•
FC-12	The fourth error information	0~3199	1	0	•
FC-13	The fourth error month and day	0~1231	1	0	•
FC-14	The fifth error information	0~3199	1	0	•
FC-15	The fifth error month and day	0~1231	1	0	•
FC-16	The sixth error information	0~3199	1	0	•
FC-17	The sixth error month and day	0~1231	1	0	•
FC-18	The seventh error information	0~3199	1	0	•
FC-19	The seventh error month and day	0~1231	1	0	•
FC-20	The eighth error information	0~3199	1	0	•
FC-21	The eighth error month and day	0~1231	1	0	•
FC-22	The ninth error information	0~3199	1	0	•
FC-23	The ninth error month and day	0~1231	1	0	•
FC-24	The tenth error information	0~3199	1	0	•
FC-25	The tenth error month and day	0~1231	1	0	•
FC -26	The last error information	0~3199	1	1	•
FC -27	Latest error speed	0.000~3.000m/s	0.001m/s	0.000	•
FC -28	Latest error current	0.0~999.9A	0.1A	0.0	•
FC-29	Latest error bus	0~999V	1V	0	•

Function Code	Name	Setting Range	Min. Unit	Default	Modification
	voltage				
FC-30	Latest error month and day	0~1231	1	0	●
FC-31	Latest error time	0~2359	1	0	●
FD Communication Parameters					
FD-00	Baud rate setting	0: 300bps 1: 600bps 2: 1200bps 3: 2400bps 4: 4800bps 5: 9600bps 6: 19200bps 7: 38400bps	1	5	★
FD-01	Data format	0: No check-out: Data format<8,N,2> 1: Even check-out: Data format<8,E,1> 2: Odd check-out: Data format<8,0,1>	1	0	★
FD-02	Local address	0 ~ 127 , 0 : Broadcasting address	1	1	★
FD-03	Responding delay	0~20ms	1ms	10ms	★
FD-04	Communication delay time	0.0~60.0s , 0.0s: invalidation	0.1s	0.0s	★
FE Lift Function Setting Parameters					
FE-00	Collective selective mode	0: Full selective 1: Down selective 2: Up selective	1	0	☆
FE-01	Hall display of floor 1	0000~1999	1	1901	☆
FE-02	Hall display of floor 2	Note: the first two numbers represent tens digit display code of the floor; the last two represent first rank code. The first rank codes are as follows: 00: display"0"	1	1902	☆
FE-03	Hall display of floor 3		1	1903	☆
FE-04	Hall display of		1	1904	☆

Function Code	Name	Setting Range	Min. Unit	Default	Modification
	floor 4	01: display"1"			
FE-05	Hall display of floor 5	02: display"2"	1	1905	☆
FE-06	Hall display of floor 6	03: display"3"			
FE-06	Hall display of floor 6	04: display"4"	1	1906	☆
FE-06	Hall display of floor 6	05: display"5"			
FE-07	Hall display of floor 7	06: display"6"	1	1907	☆
FE-07	Hall display of floor 7	07: display"7"			
FE-08	Hall display of floor 8	08: display"8"	1	1908	☆
FE-08	Hall display of floor 8	09: display"9"			
FE-09	Hall display of floor 9	10: display"A"	1	1909	☆
FE-09	Hall display of floor 9	11: display"B"			
FE-10	Hall display of floor 10	12: display"G"	1	0100	☆
FE-10	Hall display of floor 10	13: display"H"			
FE-11	Hall display of floor 11	14: display"L"	1	0101	☆
FE-11	Hall display of floor 11	15: display"M"			
FE-12	Hall display of floor 12	16: display"P"	1	0102	☆
FE-12	Hall display of floor 12	17: display"R"			
FE-13	Hall display of floor 13	18: display"-"	1	0103	☆
FE-13	Hall display of floor 13	19: no display			
FE-14	Hall display of floor 14	20: display"12"	1	0104	☆
FE-14	Hall display of floor 14	21: display"13"			
FE-15	Hall display of floor 15	22: display"23"	1	0105	☆
FE-15	Hall display of floor 15				
FE-16	Hall display of floor 16		1	0106	☆
FE-16	Hall display of floor 16				
FE-17	Hall display of floor 17		1	0107	☆
FE-17	Hall display of floor 17				
FE-18	Hall display of floor 18		1	0108	☆
FE-18	Hall display of floor 18				
FE-19	Hall display of floor 19		1	0109	☆
FE-19	Hall display of floor 19				
FE-20	Hall display of floor 20		1	0200	☆
FE-20	Hall display of floor 20				
FE-21	Hall display of floor 21		1	0201	☆
FE-21	Hall display of floor 21				
FE-22	Hall display of		1	0202	☆

Function Code	Name	Setting Range	Min. Unit	Default	Modification
	floor 22				
FE-23	Hall display of floor 23		1	0203	☆
FE-24	Hall display of floor 24		1	0204	☆
FE-25	Hall display of floor 25		1	0205	☆
FE-26	Hall display of floor 26		1	0206	☆
FE-27	Hall display of floor 27		1	0207	☆
FE-28	Hall display of floor 28		1	0208	☆
FE-29	Hall display of floor 29		1	0209	☆
FE-30	Hall display of floor 30		1	0300	☆
FE-31	Hall display of floor 31 (double door plural selection hall call address setting)		1	0301	☆
FE-32	Lift factory function selection1		0~65535 Selected by bit, the function is valid if the bit is 1, details referring to chapter 6.	1	35843
FE-33	Lift factory function selection2	Selected by bit, the function is valid if the bit is 1, details referring to chapter 6.	1	32	★
FP User Parameters					
FP-00	User password	0~65535 0: indicates no password	1	0	☆
FP-01	Parameter	0: Invalidation	1	0	★

Function Code	Name	Setting Range	Min. Unit	Default	Modification
	renewal	1 : Recover the default Parameter 2: Clear memory			
FP-02	User setting inspect	0: Invalidation 1: valid	1	0	★



Functional parameter Specification

Chapter 6 Function parameter description

6.1 F0 Group Basic Function Group

F0-00	Control mode	Default	1	Min. Unit	1
	Setting Range	0、1			

Select the control mode of the system.

0: Open-loop vector. Speed sensorless vector control. It is mainly applicable for low speed running in adjusting and fault judging in maintaining of asynchronous motor.

1: Close-loop vector. Vector control with speed sensor. It's used for distance control in normal running.

NOTE: The synchronous motor doesn't use open-loop vector. Please tune the motor before lift inspection running.

F0-01	Command source selection	Default	1	Min. Unit	1
	Setting Range	0、1			

It can set the lift running type with travel mode and speed command.

0: Operating panel command channel. Press the buttons such as RUN, STOP on the operating panel to perform the command control. The traveling speed is decided by parameter F0-02(Panel controller running speed).

1: Distance control. It is used for NICE3000. When it's in inspection running the lift run with the speed according to the setting of parameter F3-1; it enables direct parking according to the distances from the current land to the target land while calculating running speed and curves automatically.

F0-02	Operating panel speed	Default	0.050m/s	Min. Unit	0.001m/s
	Setting Range	0.050~F0-04			

This function is only used when function code is F0-01=0(operating panel command channel).

It sets the default of speed when lift is used by operating panel. You can modify this code to change speed of operating panel control when

traveling.

F0-03	Lift Max. running speed	Default	1.600 m/s	Min. Unit	0.001m/s
	Setting Range	0.250~F0-04			

It can set the Max. Speed when the lift is running and it should below rated speed of the lift.

F0-04	Lift rated speed	Default	1.600 m/s	Min. Unit	0.001m/s
	Setting Range	0.250~4.000m/s			

It means rated speed of nameplate of lift. This function parameter is decided by the machine and motor of the lift. The parameter F0-03 means the actual speed within the speed range of F0-04.

For example: One lift rated speed is 1.750 m/s, but the actual Max.speed is 1.720 m/s. So F0-03 = 1.720 m/s; F0-04 = 1.750 m/s.

F0-05	Lift rated load	Default	1000kg	Min. Unit	1kg
	Setting Range	300~9999kg			

It can set the rated load of lift. This code is used for anti-nuisance function.

F0-06	Max. frequency	Default	50.00Hz	Min. Unit	0.01Hz
	Setting Range	20.00~99.00Hz			

It can set Max. Frequency of system output and the frequency must be higher than rated frequency of the motor.

F0-07	Carrier frequency	Default	6kHz	Min. Unit	0.1kHz
	Setting Range	0.5~16.0kHz			

The magnitude of carry frequency ties up the noise of motor running. The carry frequency is generally set upward 6 KHz to manage to travel without noise. To the best of noise allowing range, reduce the carry frequency

When the carrier frequency is low, the output current higher-harmonic component increases, the consumption and temperature rise of the motor increase as well.

When the carrier frequency is high, the motor consumption declines and the motor temperature rise reduces, but the consumption, temperature rise and interference of the system increase.

To regulate the carrier frequency will exert influences on the following performances:

Carrier Frequency	L o w	~	H i g h
Motor noise	L a r g e	~	S m a l l
Output Current Wave Form	B a d	~	G o o d
Motor Temperature Rise	H i g h	~	L o w
System Temperature Rise	L o w	~	H i g h
Leakage Current	S m a l l	~	L a r g e
External Radiation Interference	Small	~	Large

6.2 F1 Group Motor Parameters

Function code	Name	Default	Min. Unit	Setting Range
F1-00	Selection of encoder's type	1model	1	0: SIN/COS 1:UVW

The parameter is invalidation for the asynchronous motor. For synchronous motor UVW selects 1, ERN1387 SIN/COS encoder selects 0.

Function code	Name	Default	Min. Unit	Setting Range
F1-01	Rated power	Depending on the model	0.1kW	1.1~75.0kW
F1-02	Rated voltage	380V	1V	0~440V
F1-03	Rated current	Depending on the model	0.01A	0.00~655.00A
F1-04	Rated frequency	50.00Hz	0.01Hz	0.00~99.00Hz
F1-05	Rated rotation speed	1460rpm	1rpm	0~3000rpm

Please set according to the nameplate parameters of the motor.

The system has motor parameter self-tuning function. Only when the motor's parameter is setting correctly can the system complete parameter tuning function correctly to fulfill good vector control function.

Function code	Name	Default	Min. Unit	Setting Range
F1-06	Stator resistance	Depending on	0.001Ω	0.000~30.000Ω

Function code	Name	Default	Min. Unit	Setting Range
	(Asynchronous motor)	the model		
	Encoder initialized angle (Synchronous motor)	Depending on the mode	0.1°	0~359.9°
F1-07	Rotor resistance(asynchronous) Current angle(sync)	Depending on the model 0.1	0.001Ω	0.000~30.000Ω
F1-08	Leakage inductance (Asynchronous motor)	Depending on the model	0.01mH	0.00~300.00mH
	Wiring connection (Synchronous motor)	Depending on the model	1	0~15
F1-09	Mutual inductance	Depending on the model	0.1mH	0.1~3000.0mH
	ADC sampling delay function (sync)	0.0	0.1	0-40
F1-10	No-load current	Depending on the model	0.01A	0.01~300.00A
	Selection check of encoder's signal	0.0	0.1	0-31

To ensure system performance, please set according to the system standard of the motor arrangement. If the motor power is a lot different from the standard motor power, the performance of system control will decline.

The parameter F1-06 means different meaning when used in different motors. When it's used in asynchronous motor, it means the stator resistance. When it's used in synchronous motor, it means the encoder initialized angle. No matter which motor to be used in, this parameter can be created after NICE3000 tuning. And users can modify this parameter

according to actual condition.

If the automatic tuning of the motor is completed normally, the setup values in F1-F6 to F1-F10 will update automatically.

If the type of encoder is SIN/COS, F1-10 parameter is selection check of encoder's signal, setting as 1 before tuning and 2 after tuning.

When NICE3000 is used for asynchronous motor: the system can gain these parameters through with-load tuning (static tuning) or no-load tuning (complete tuning). If the motor cannot be tuned on the spot, the known parameters of the same kind of motors can be a reference for manual input. After modifying the asynchronous motor's rated power F1-01, the parameter values in F1-06 to F1-10 will automatically recover to the default standard motor parameters.

When NICE3000 is used for permanent-magnet synchronous motor: NICE 3000 can gain parameters F1-06, F1-08 through with-load tuning and no-load tuning. After modifying the rated power F1-01, the parameter values in F1-06 to F1-10 will not automatically recover.

F1-11	Tuning selection	Default	0	Min. Unit	1
	Setting Range	0、1、2、3			

Note: The correct motor rated parameters (F1-01~F1-05) must be set before tuning.

0: No tuning.

1: With-load tuning while in use, motor's load won't affect the tuning result.

2: No-load tuning. It requires complete separation from the motor to the load. While in tuning the motor will run and the motor's load will affect the tuning result.

3: Well self-tuning: It's in need before the motor begins to run fast.

To ensure the dynamic control performance of the controller, please select the complete tuning. When performing the complete tuning, the motor must be separated from the load (no-load).

After selecting the complete tuning, the controller will firstly perform the static tuning. When the static tuning is completed, the asynchronous motor will be accelerated to 80% of the motor rated power according to the

acceleration time set in F3-02. And it will maintain this status for a period of time. Then it will be decelerated to zero according to the deceleration time set in F3-05. The complete tuning is then ended; the synchronous motor step positively and negatively to judge the pulse wheel encoder origin point.

After the F1-11 is set as 1 or 2, press the ENTER key to display “TUNE” that is flashing. Then press the RUN button to perform the parameter tuning, the “TUNE” stops flashing. After the tuning is completed, it will display the stop status interface. And the STOP button can be pressed in the tuning process to suspend the tuning.

After the tuning is completed, the values in F1-11 will automatically recover as 0.

Attention: if using the permanent-magnet synchronous motor, the system must be complete tuning. Because the system doesn't only to recognize related parameters, but also to recognize encoder original point. It is forbidden that travel the permanent-magnet synchronous motor before complete the complete tuning.

▲ Automatically tuning step of asynchronous motor is following:

For asynchronous motor, F1-11 selects 1, the motor won't run and it needn't to get rid off the rope. While in self-tuning, there's noise of motor's current. F1-11 selects 2, the motor will run and it need to get rid off the rope.

(1) First, set F0-01 as 0: the control mode selection is the operating panel command channel.

(2) Set F1-00 as 0 by actual motor types: asynchronous motor. Then set F1-01、F1-02、F1-03、F1-04、F1-05 according to the nameplate parameters of motor.

(3) If the motor can be separated from load, the parameter F1-11 selects 2(motor no-load tuning).Then press **RUN** of the operating panel and the motor can automatically run. The control automatically counts these parameters as follows: F1-06 (stator resistance), F1-07 (rotor resistance), F1-08 (leakage inductance), F1-09 (mutual inductance) and F1-10 (no-load excitation current). The motor tuning is then over. If the system appears over current, please increase the parameter F1-10, but don't exceed 20%.

(4) If the motor can't be separated from load, the parameter F1-11 selects 1(motor with-load tuning).Then press **RUN** of the operating panel and the motor can automatically tune. The controller only automatically counts three parameters: stator resistance, rotor resistance, and leakage inductance. It automatically counts mutual inductance and no-load current of motor as well.

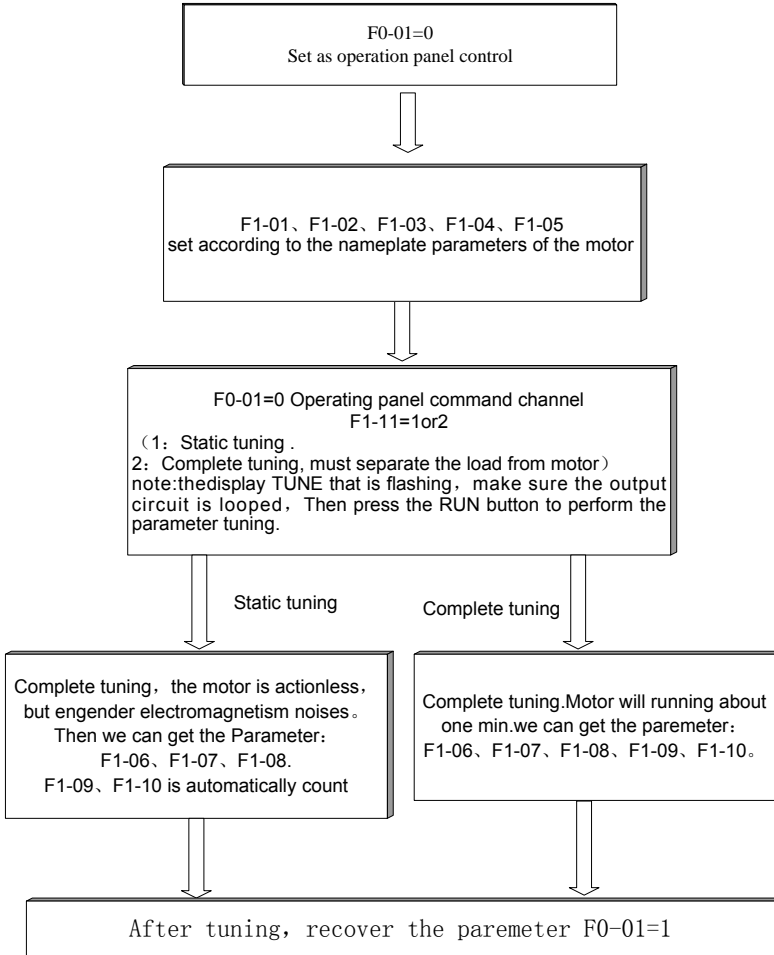

Chart 6-1 Asynchronous motor tuning flow chart

▲ Automatically tuning step of permanent-magnet synchronous motor is following:

(1) First, set F0-01 as 0: the control mode selects the operating panel command channel.

(2) Set F1-00 as 0 by actual motor type: synchronous motor. Then set F1-01、F1-02、F1-03、F1-04、F1-05 according to the nameplate parameters of motor.

(3) Completely separate the motor from the load (rope), the parameter F1-11 selects 2(complete tuning). Then press **RUN** of the operation panel and the motor can automatically run. The controller automatically counts the F1-06 encoder initialized angle. The motor tuning is then over. Operate the tuning more than 3 times, then compare F1-06 encoder initialized angle already gained, make sure the error is within the range of $\pm 5^\circ$.

(4) After tuning, set F0-02=0.5 m/s, and press **RUN**. Check if the motor running is right or not. If motor isn't running right, please repeat step 1, 2, 3 after transposing direction of encode signal.

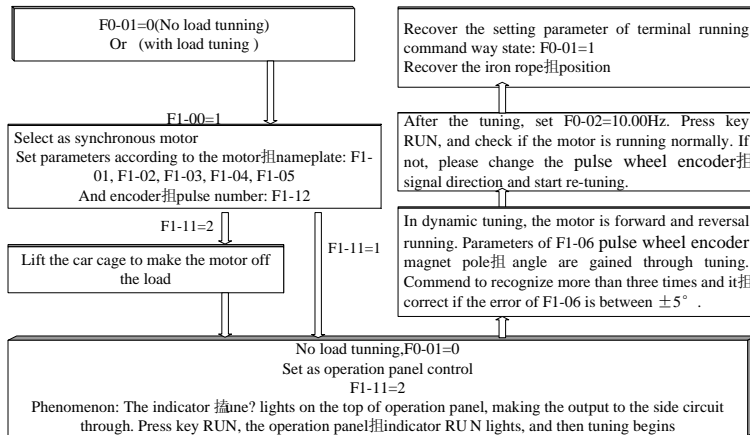

Chart 6-2 Adjusting flow chart of permanent-magnet synchronous motor

- (1) Before the first running, the magnet pole identification is necessary for the permanent-magnet synchronous hoist motor, otherwise it can't be normally used. After the change of motor wiring, encoder and encoder wiring, it's needed to re-recognize the pulse wheel encoder's position angle. Therefore, the motor wiring, PG card

wiring must be the same when in recognizing the magnet pole's position and the motor normally running. In the identification course, the motor will run, so you must assure that the synchronous hoist motor which is recognized must be in no load state.

- (2) Before the identification, the parameters of F1 group motor's nameplate must be inputted correctly, including rated frequency, rated voltage, rated power, rated rotation speed, rated current. And set the encoder's pulse number (F1-12) correctly. Then set F1-11 as 2 and press key "confirm", the inverter will display "TUNE". Press key RUN, the inverter begins to recognize. The inverter will display "TUNE" all through the identification course. When the "TUNE" disappears, the identification is then over.
- (3) The result of the identification is the encoder's installation angle. It's located in the F1-06 function, and can be checked and modified. The parameter modification is forbidden after the position identification. Otherwise the inverter can't run normally.

After the identification, F1-06, F1-08 are setting as motor control reference. Users needn't modify it. Otherwise the lift can't run normally.

If alarming error E20 occurs in the encoder position's identification course, please check whether the PG card is correctly connected. The inverter adopts the vector control mode with a transducer (assure parameter F0-00 is 1), and it must connect with PG card and encoder correctly. Otherwise alarm E20 displaying on the panel to indicate encoder's error.

If E21 alarms in the starting, check that whether the identification result parameters F1-06 and F1-08 are correct t. If it's ensured that the wiring of motor and PG card isn't changed, you can directly input the two data recorded after the first identification, or re-recognize the pulse wheel encoder's position angle.

Recommendation: Recognize the encoder's position several times, compare with the data of F1-06, if the error is without $\pm 5^\circ$, which indicates errors exist in the encoder or wiring.

2. Running trial

After the encoder's position identification, do the running trials with no load (the traction machine with no iron wires) before the recovery. The mode of running trial is recommended to adopt inspection up and down buttons, at

the moment, deal with the safety circuit and door lock circuit according to the system condition. In the running trial course, the following two points need specially care:

- 1) If the direction of the traction machine is corresponding to the reality (Up and Down), if not, it needs to adjust the NICE 3000 wiring outputting to the motor, re-recognize the encoder's position.
- 2) Whether the traction machine's forward and reversal running are stable and no noise; because of no load in the traction machine, the current will be extremely small and NICE 3000 displays the current lower than 1A.

After the confirmation of the two points, NICE 3000 have recorded the traction machine's encoder position correctly into F1-06 (Users can record it down for the later using), and it can do the normal control. The following step is adjusting according to the lift's normal adjusting course. Due to the different features of synchronous motor and asynchronous motor, user can reduce the speed loop P1 gain of F2 group when in use.

Note: After the lift is using normally, adjust the motor wiring and encoder wiring will both cause the lift can't be normally used.

The usually used parameters:

▲ Well parameter self-tuning is used to record the position of well's opening and closing (Including leveling switch and force reducer switch). Requirements are as follows:

- (1) Encoder and leveling feedback is normal; the switch of the well is installed well.
- (2) The lift is in the ground floor, forced deceleration switch operation.
- (3) The lift is in examination and can check running.
- (4) The lowest and highest floors are set correctly.
- (5) NICE 3000 is not in the error alarming state.

Note: Well self-tuning can also be realized by the small keyboards on the main control panel. Two floor self-tuning needs the lift run under the first leveling which means there's one leveling sensor under the leveling plate..

F1-12	Encoder pulse	Default	1024	Min. Unit	1
--------------	----------------------	---------	------	-----------	---

	number per rotation				
	Setting Range	0~10000			

It can set the pulse number of each rotation of the encoder, according to the nameplate of encode.

Note: it must set the encoder pulse number correctly when it's in the closed loop vector control. Otherwise it cannot work normally. If the asynchronous motor still cannot work normally after the encoder pulse number set correctly, please exchange the connection line between the phase A and B of the encoder. The encoder pulse number of permanent-magnet synchronous motor must be set according to the UVW encoder, and the pulse number per rotation should be set according to the encoder nameplate.

F1-13	Encode failure monitoring times	Default	3.0s	Min. Unit	0.1s
	Setting Range	0.0~10.0s			

It can set monitoring time when encode fault occurs. After lift starts running with speed of nonzero, the system begins to receive signal of encoder every time of F1-13 setting. If there's none signal input, the system will show Err20 which means encoder failure.

6.3 F2 Group Vector Control Parameters

Function code	Name	Default	Min. Unit	Setting Range
F2-00	Proportional gain 1 of speed loop	40	1	0~100
F2-01	Integration time 1 of speed loop	0.60s	0.01s	0.01~10.00s
F2-02	Switching frequency 1	2.00Hz	0.01Hz	0.00~F2-05
F2-03	Proportional gain 2 of speed loop	35	1	0~100
F2-04	Integration time 2 of speed loop	0.80s	0.01s	0.01~10.00s
F2-05	Switching frequency 2	5.00Hz	0.01Hz	F2-02~F0-05

The parameters of F2-00 and F2-01 decide the dynamic response characteristic of the frequency that is smaller than the switching frequency 1 (F2-02), while the parameters of F2-03 and F2-04 decide the dynamic response characteristic of the frequency that is larger than the switching frequency 2 (F2-05). The dynamic response characteristic parameters of the frequency between the switching frequency 1 and switching frequency 2 equal to the weighted average value of two set of F2-00、F2-01 and F2-03、F2-04. As shown in Chart 6-2:

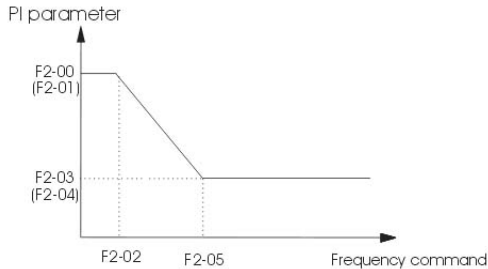

Chart 6-2 PI Parameters Schematic Diagram

It can regulate the speed dynamic response characteristic of the vector control by setting the proportional coefficient and integrating time of the speed regulator. It can accelerate the dynamic response of the speed loop by increasing the proportional gain or decreasing the integrating time. Too large the proportional gain or too small the integrating time will cause the system to vibrate.

The regulating methods are recommended as follows:

If the factory parameters cannot satisfy the requirements, conduct minor adjustment on the basis of the factory parameters:

Enlarge the proportional gain first to prevent the system from vibrating, and then diminish the integrating time to ensure that the system has fast response characteristic and small overshoot.

If switching frequency 1 and switching frequency 2 are set as 0 at the same time, only F2-03 and F2-04 are virtual value.

Note: Once the PI parameters are set inappropriately, it will cause large overshoot speed and even voltage fault when the overshoot returns to the normal level.

F2-06	Proportional gain of current loop	Default	60	Min. Unit	1
	Setting Range	100~500			
F2-07	Integral gain of current loop	Default	30	Min. Unit	1
	Setting Range	100~500			

F2-06, F2-07 are current loop adjusting parameters in the vector control arithmetic. The adjusting method is the similar with that of parameter of speed loop P1. The adjustment in the synchronous motor has a obvious effect on the feeling of comfort. Appropriate adjustment can restrain the vibration while the lift is running.

F2-08	Upper limit of torque	Default	150.0%	Min. Unit	0.1%
	Setting Range	0.0~200.0%			

It can set upper limit of torque of motor. The setup 100% corresponds to the rated torque of the motor that matches the system.

F2-10	Running direction	Default	0	Min. Unit	1
	Setting Range	10、1			

0: The same direction

1: The running direction choose reversal, position pulse direction choose reversal

2: The same running direction, position pulse direction choose reversal

3: The running direction choose reversal, position pulse direction choose the same

In this function code, it can choose reversal of running direction (Motor's running direction when the connection of motor didn't change), and position signal (Means F4-03 used for identify the pulse direction of lift's position). For example, After the installation of the lift, up running inspection while lift's actual running direction is down running, so running direction needs choose reversal; while up running inspection, the position pulse F4-03 reduced (position lower), so position pulse direction needs choose reversal.

Please pay attention to the setting of parameters while recover the default.

6.4 F3 Group Running Control Parameters

F3-00	Starting speed	Default	0.010m/s	Min. Unit	0.001m/s
	Setting Range	0.000~0.030m/s			
F3-01	Time keeping	Default	0.150s	Min. Unit	0.001s
	Setting Range	0.000~0.500s			

Setting of starting speed can increase the ability to overcome the static friction. But if the setting of starting speed is too big, it can generate impact feeling at starting time. The using of two parameters can smooth of lift starting.

F3-02	Acceleration	Default	0.600m/s ²	Min. Unit	0.001m/s ²
	Setting Range	0.200~2.000m/s ²			
F3-03	Inflexion speedup time 1	Default	2.500s	Min. Unit	0.001s
	Setting Range	0.300~4.000s			
F3-04	Inflexion speedup time 2	Default	2.500s	Min. Unit	0.001s
	Setting Range	0.300~4.000s			

The three function codes decide the S curve parameters of lift speedup running:

F3-02 is acceleration of S curve of lift speedup running.

F3-03 is the time which is cost from 0 to the parameter F3-02 of S curve speedup stage. The bigger this parameter is, the slower curve inflexion is.

F3-04 is the time which is taken from the change of acceleration from 0 to that of F3-02 in the S curve speedup stage. The bigger this parameter is, the slower the flatter the curve inflexion is.

F3-05	Deceleration	Default	0.600m/s ²	Min. Unit	0.001m/s ²
	Setting Range	0.200~2.000m/s ²			
F3-06	Inflexion	Default	2.500s	Min. Unit	0.001s

	slow-down time 1				
	Setting Range	0.300~4.000s			
F3-07	Inflexion slow-down time 2	Default	2.500s	Min. Unit	0.001s
	Setting Range	0.300~4.1000s			

The three function codes decide the S curve parameters of lift slow-down running:

F3-05 is deceleration of S curve of lift slow-down running.

F3-06 is the time which is taken from the change of deceleration from F3-05 to 0 in the S curve slow-down stage. The bigger this parameter is, the flatter the curve inflexion is.

F3-07 is the time which is taken from the change of deceleration from 0 to that of F3-05 in the S curve slow-down stage. The bigger this parameter is, the flatter the curve inflexion is.

The setting of S curve is as follows:

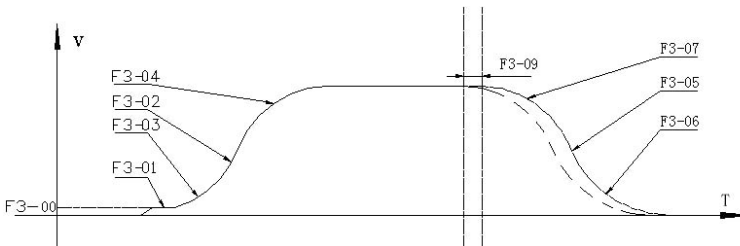

Chart 6-3 Speed Curve Chart

F3-08	Special deceleration	Default	0.900m/s ²	Min. Unit	0.001m/s ²
	Setting Range	0.500~2.000m/s ²			

This parameter sets the deceleration of the lift forced reducer, well self-tuning and maintenance. If pulse numbers are far different from the

budget numbers as lift force reducer acting, lift speed-down to 0.1m/s by special deceleration and travel to leveling position.

The setting of this parameter is: $F3-08 \geq \frac{(F0 - 03)^2}{2 \times (F3 - 13)}$, adjust according to the actual situation.

F3-09	Pre-distance of stop	Default	0.0mm	Min. Unit	0.1mm
	Setting Range	0~90.0mm			

It means the advanced distance of lift distance control when the lift is slow-down. It is used to clear up the influence of coder signal missing or leveling signal delaying. Generally users don't change it.

F3-10	Re-leveling speed	Default	0.040m/s	Min. Unit	0.001m/s
	Setting Range	0.000~0.050m/s			

It means the re-leveling speed when the lift is in the door zone. Because the length of leveling plate is different in different system, the parameter adjusting can assure the landing accuracy of re-leveling. It is used when chooses the re-leveling function through FE-32..

F3-11	Low-speed running	Default	0.250m/s	Min. Unit	0.001m/s
	Setting Range	0.100~0.630m/s			

It can set the low speed of running when the lift is running in inspection or well self-tuning.

F3-12	Switching position of the NO.1 up force reducer	Default	0.00m	Min. Unit	0.01m
	Setting Range	0.00~300.00m			
F3-13	Switching position of the NO.1 down force reducer	Default	0.00m	Min. Unit	0.01m
	Setting Range	0.00~300.00m			

F3-14	Switching position of the NO.2 up force reducer	Default	0.00m	Min. Unit	0.01m
	Setting Range	0.00~300.00m			
F3-15	Switching position of the NO.2 down force reducer	Default	0.00m	Min. Unit	0.01m
	Setting Range	0.00~300.00m			
F3-16	Switching position of the NO.3 up force reducer	Default	0.00m	Min. Unit	0.01m
	Setting Range	0.00~300.00m			
F3-17	Switching position of the NO.3 down force reducer	Default	0.00m	Min. Unit	0.01m
	Setting Range	0.00~300.00m			

NICE3000 can set 3 pairs of switches of force reducer at most. Its setting position is: the sequence is followed by the installation of NO.1, NO.2, and NO.3 force reducer switches from the end to the middle of the well. That means **the switch of the NO.1 is built near the terminal landing.**

In the low-speed lift, there may be only one pair of switches of force reducer. And there are two or three pairs of switches of force reducer in the high-speed lift. The system can self-motion monitor the running speed when lift run to the switching position of force reducer, and prevent car and counterweight from resting the butter because of the abnormality speed.

This parameter of distance means the distance from switch position to the lowest floor. It can self-motion note according to the lift self-tuning.

Propositional position:

Switch		NO. 1 force reducer	NO. 2 force reducer	NO. 3 force reducer
Distance	$\leq 1.5\text{m/s}$	1.5m		
	$2.0\text{m/s} > v > 1.5\text{m/s}$	1.5m	3.5m	
	$\geq 2.0\text{m/s}$	1.5m	3.5m	5m

S means the setting distance of switch of forced reducer to leveling position. The distance S must be enough for the deceleration from F3-08 to 0. That means S must suffice following conditions:

$$S > \frac{V^2}{2 * F3 - 08}$$

If the distance of forced reducer is too short, the system will alarm failure E45 after lift self-tuning .It can be solved through increasing the distance of switch position of forced reducer or parameter F3-08.

F3-18	Time of starting output with zero speed	Default	0.200s	Min. Unit	0.001s
	Setting Range	0.000~1.000s			

To protect lift starting ride comfort, the lift control can run with zero speed before brake opening. At this time, motor is in excitation traveling, and it outputs biggest starting torque.

F3-19	Time-lag of curve running	Default	0.200s(asynchronous) 0.500s(sync)	Min. Unit	0.001s
	Setting Range	0.000~1.000s			

This parameter sets time that it takes from the system outputting open signal to the brake complete opening. It usually needs about 200ms.The system keeps up outputting with zero speed.

F3-20	Time-lag of end running	Default	0.300s	Min. Unit	0.001s
	Setting Range	0.000~1.000s			

It means holding time of zero speed when the curve running ends. Users needn't modify it.

In running course, the connection of each signal with curve is as follows:

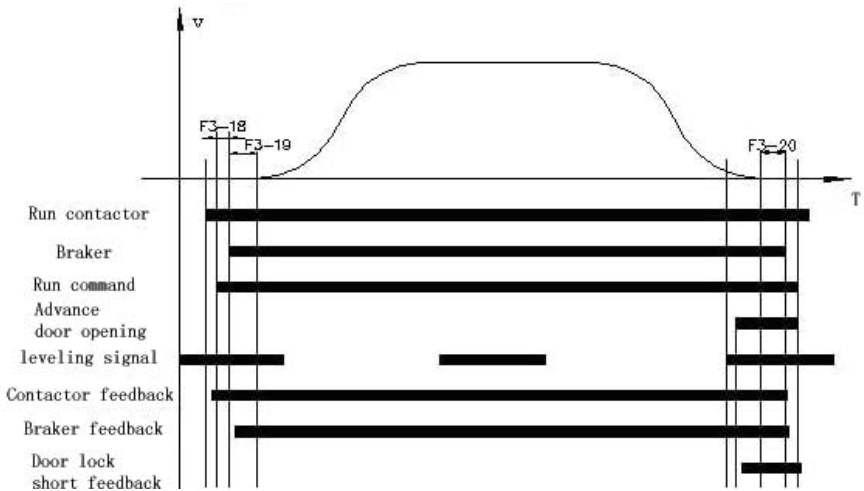

Chart 6-4 Running time sequence chart

6.5 F4 Group Position Parameters

F4-00	Leveling adjusting	Default	30mm	Min. Unit	1mm
	Setting Range	0~60mm			

It ensures the landing accuracy of lift. If the position of leveling inductor isn't in the middle of inductor plate when the lift stops, adjust this parameter. If lift is over leveling when stops, reduce the value of F4-00. If lift is under leveling when stops, increase it. NICE3000 integrates advanced arithmetic of distance control. And it use multi-measures to confirm stability of direct parking. Generally users need not adjust it.

F4-01	Current floor	Default	1	Min. Unit	1
	Setting Range	The lowest floor (F6-01) ~The highest floor (F6-00)			

It can show the current floor of car.

The system can self-motion recompile this parameter when lift is running. And the system can self-motion revise this parameter at leveling position after touching switch of up or down forced reducer. When lift is in non-bottom or non-top floor, users can hand recompile this parameter. But this parameter must accord with the current floor.

Function code	Name	Default	Min. Unit	Setting Range
F4-02	High bit of current floor	1	1	0~65535
F4-03	Low bit of current floor	34464	1	0~65535

It can show the number of pulse that the current floor relative to the lowest leveling floor.

Function code	Name	Default	Min. Unit	Setting Range
F4-04	High bit of leveling plate	0	1	0~65535
F4-05	Low bit of leveling plate	0	1	0~65535

It can show the pulse number of leveling plate's practical length. It is noted when self-tuning in well. Users can adjust it according to practical status.

Function code	Name	Default	Min. Unit	Setting Range
F4-06	High bit of floor high 1	0	1	0~65535
F4-07	Low bit of floor high 1	0	1	0~65535
⋮	⋮	⋮	⋮	⋮
F4-64	High bit of floor high 30	0	1	0~65535
F4-65	Low bit of floor high 30	0	1	0~65535

The bit of floor height i means the pulse number of height between floor i leveling plate to floor (i+1) leveling plate. Every height corresponds to one number of 32 bit numbers in binary system. Among those, high 16 bit parallels high bit of this floor height, and low 16 bit parallels low bit of this floor height.

For example: the floor height from floor 4 to floor 5 is F4-12=6, F4-13=54321. In binary it shows as follows:

0000, 0000, 0000, 0110, 1101, 0100, 0011, 0001

Practical pulse number will be displayed as 447537 in decimal system.

6.6 F5 Group Terminal Function Parameters

Function	Name	Default	Min. Unit	Setting Range
----------	------	---------	-----------	---------------

code				
F5-00	Driver switch time and time-switching automatically	3s	1	1~200s

When there's calling from other floors in driver state, it will turn to the normal state automatically after F5-00 time; then return to driver state after the running.

When the parameter of F5-00 is smaller than 5, the mentioned function is cancelled, then it's the same with the normal driver function.

Function code	Name	Default	Min. Unit	Setting Range
F5-01	Selection function of terminal X1	33	1	00~59
F5-02	Selection function of terminal X2	35	1	00~59
⋮	⋮	⋮	⋮	⋮
F5-23	Selection function of terminal X23	00	1	00~59
F5-24	Selection function of terminal X24	00	1	00~59

X1~X24 is switch input terminal, and they can select corresponding function codes 00~61. The same function code can't be used repeatedly. If the terminal X1 input signal is 24V, the signal light X1 of the main operation panel will light. The rest may be deduced by analogy. The code of every function is as follows:

00: No function

The controller does not work even if the signal is inputted. Set the unused terminals as none to prevent error work.

01: N.O. input of up leveling 02: N.O. input of down leveling
03: N.O. input of door zone

The system can control lift leveling stopping by signal of level transducer. The system can support up level transducer + down level transducer, or up level transducer + down level transducer + door zone transducer. If the system uses three level transducers, lift with up running will receive the signal of up leveling, the signal of door zone, and the signal of down leveling in turn; lift with down running will receive the signal of down leveling, the signal of door zone, and the signal of up leveling in turn. If the system uses up level transducer and down level transducer, lift with up running will receive the signal of up leveling, and the signal of down leveling in turn, and lift with down running will receive the signal of down leveling, and the signal of up leveling in turn. Door zone signal will be used in the function of door open re-leveling and advanced door opening. If the leveling transducer signal is deviant (conglutination or cut-off), the system will indicate E22 error.

04: N.O. input of Safety circuit feedback 05: N.O. input of Lock circuit feedback

The safety circuit is the important guarantee of lift safety running. The lock circuit insures that the landing door and car door are closed when lift starts running. It is the necessary condition of lift running that the safety circuit feedback and lock circuit feedback is effective.

06: N.O. input of running output feedback 07: N.O. input of brake contactor feedback signal

The system monitors the signal of running feedback and brake feedback after two sec. when the running contactor is cut.

**08: N.O. input of inspection signal 09: N.O. input of inspection up
10: N.O. input of inspection down**

When the “Auto/ Inspection” switch points to “Inspection”, lift comes into inspection state, the system cancel all auto running include auto-door operation. When inputted inspection up or down running signal, lift will run with inspection speed.

11: N.O. input of fire signal

When the “fire” switch is open, lift comes into fire state. The system will cancel all entered landing call and car call; the lift will park at the next land and pass the fire landing without opening the door. Lift won't open door for setting passengers free until arriving at the fire landing.

12: N.O. input of up end signal 13: N.O. input of down end signal

The signals of up end and down end are the terminal stopping switches for preventing car and counterweight rest when the lift passed the leveling station of landing without stopping.

14: N.O. input of over loading

If the lift loading is over 110% of rated load, the system comes into over loading state. The over loading buzzer tweets, the car light of over loading lights and lift doesn't close the door. If the door lock is closed, the over loading signal is impotent. In the lift checking course, if the system need run with 110% over loading, it can set F7-06=1 to control.

15: N.O. input of full loading

The lift loading among 80%~110% is full loading state, the land hall lantern shows full loading ,the lift doesn't answer the hall call.

16: N.O. input of NO.1 up force reducer 17: N.O. input of NO. 1 down force reducer
18: N.O. input of NO.2 up force reducer**19: N.O. input of NO. 2 down force reducer 20: N.O. input of NO.3 up force reducer**
21: N.O. input of NO. 3 down force reducer

These functional codes set input point into N.O. input of force reducer, corresponding to the force reducer switch signal. NICE 3000 system records these positions of switches into parameters of F3 group.

22: N.O. input of lock output feedback

The lift opens the door in advance when arriving at the floor or the lift jumps out door lock when re-leveling after opening the door. It sends feedback signal for insuring the lift running with re-leveling speed.

23: N.O. input of motor firemen overloading

The firemen switch input point is used for firemen to run the lift (twice fire control).When the fire back to base floor is running, the system will get into the firemen running state if there's firemen signal.

24: N.O. input of front light curtain

This function code terminal setting is used for the front light curtain signal

N.O. input.

25: N.O. input of back light curtain

This function code terminal setting is used for the back light curtain signal N.O. input.

26: N.O. input of brake output feedback2

This function code terminal setting is used for the brake action feedback N.O. input in lift factual running state.

27: Valid N.O. input of UPS

This function code terminal setting is used for the power failure emergency travel N.O. input. Details refer to the adjusting explanation in chapter 7.

28: N.O. input of lift-locking

The input point for locking the lift, it is in the similar function with hall call lift-locking.

29: N.O. input 2 of safety signal

It adds the second safety circuit inputting point in order to protect against the accidents caused by the pick-up of the safety circuit feedback contactor. If both input points are selected NICE3000 system certificates the normal work of the safety circuit only when both are valid. Otherwise, the system will be in E4 indication.

30: N.O. input of synchronous motor self-locking feedback

Synchronous motor self-locking contactor can ensure that there won't be far speed running even if the brake is out of work. It can be set through FE-33.

31: N.O. input of door lock circuit2 feedback

The function of door lock circuit2 is the same with that of door lock circuit1. It's convenient for the users to separate the signals from the hall door to car door. The door lock is considered locked only when the two door lock circuit feedback signals are connected.

33~63

These 31 parameters are corresponding with parameters 01~31.The

parameters 01~31 input terminal are set as N.O. input, but the parameters 33~63 are set as N.C. input.

Function code	Name	Default	Min. Unit	Setting Range
F5-25	Car top input type selection	64	1	0~255

It can set definite types of signals of the car top control panel by bit.

0: N.C. input; 1: N.O. input

For example: one lift need set car top input signal type as the following list:

Binary digit	Parameter	Type setting	Binary digit	Parameter	Type setting
Bit0	Font door beam screen	N.C.	Bit4	Front door-close limit	N.C.
Bit1	Back door beam screen	N.C.	Bit5	Back door-close limit	N.C.
Bit2	Front door-open limit	N.C.	Bit6	Digital load 3 (full load)	N.O.
Bit3	Back door -open limit	N.C.	Bit7	Digital Load 4 (over load)	N.C.

The binary system shows 01000000, corresponding decimal system count shows 64. So the parameter F5-25 is set as 64.

For example: when font door beam screen is N.O. Binary digit shows 01000001, corresponding decimal system count shows 65. So the parameter F5-25 is set as 65;

Function code	Name	Default	Min. Unit	Setting Range
F5-26	Y1 function selection	1	1	0~16
F5-27	Y2 function selection	2	1	0~16
F5-28	Y3 function selection	3	1	0~16
F5-29	Y4 function selection	4	1	0~16
F5-30	Y5 function selection	0	1	0~16

F5-31	Y6 function selection	0	1	0~16
-------	-----------------------	---	---	------

The system output is relay output. There are function items 0~16:

0: No function:

Output terminal hasn't any function.

1: Run contactor output:

The system outputs the pick-up command of run contactor; control the run contactor's pick-up and release.

2: Brake contactor output:

The system outputs the pick-up command of brake contactor, achieving the output signal of brake and release control.

3: Lock contactor output:

The system outputs the pick-up command of envelop door contactor, fulfilling pre-opening, door lock jump out when micro leveling, and release control.

4: Fire arrival land signal feedback:

When in fire state, the system sends out feedback signal to monitor after lift returns to the fire land.

5: Front door open:

The corresponding terminal is used for outputting the signal of front door open.

6: Front door close:

The corresponding terminal is used for outputting the signal of front door close.

7: Back door open:

The corresponding terminal is used for outputting the signal of back door open.

8: Back door close:

The corresponding terminal is used for outputting the signal of back door close.

9: Brake, run contactor normal:

The corresponding terminal is used for outputting normal signal of the brake and run contactor. When the system shows E37, E36, it means the brake and run contactor error and the terminal don't output.

10: Failure state:

The corresponding terminal is used for outputting signal when errors occur in 3, 4, and 5 ranks. The ranks of errors are in chapter 8.

11: Run monitor:

NICE 3000 is in running state.

12: Synchronous motor auto-run:

It's the self-locking contactor to control permanent-magnet synchronous motor. If the synchronous motor is in self-running emergency when the lift is in power failure emergency running state, the brake open, the corresponding terminal output, lift slip into the nearest leveling land and open door. Details are in chapter 7, user introduction. In addition, it can be used after the lift stops in normal condition to enhance safety.

13: Power failure emergency running efficiency:

When lift is in power failure emergency running state, the corresponding terminal will output. Details are in chapter 7, adjusting explanation.

14: System normal:

When the system is in normal work condition, the corresponding terminal will output. This function can be used for parallel or group control.

15: Emergency buzzer output

It will indicate the leveling condition when it's in emergency condition.

16: Brake forced output

Open the brake and last 4s each time; it can be used to control the starting voltage of the brake.

Function code	Name	Default	Min. Unit	Setting Range
F5-32	Hall call condition display			

When users enter F5-31 menu, the tube on the keyboard shows the output terminal state at present. The keyboard tube order is 5, 4,3,2,1 from left to

right. Every passage's definition is as follows:

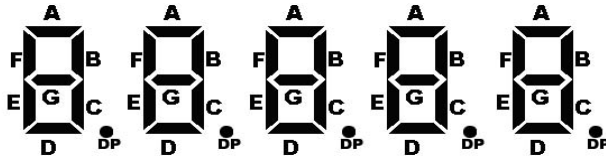

The meaning of each passage is listed in the following charts:

Tube Serial number	Tube passage marker	Meaning of tube passage "light"	Meaning of tube passage "No light"
1	A	Outside call communication of address dial-up 1 normal	Outside call communication of address dial-up 1 deviant
	B	Outside call communication of address dial-up 2 normal	Outside call communication of address dial-up 2 deviant
	C	Outside call communication of address dial-up 3 normal	Outside call communication of address dial-up 3 deviant
	D	Outside call communication of address dial-up 4 normal	Outside call communication of address dial-up 4 deviant
	E	Outside call communication of address dial-up 5 normal	Outside call communication of address dial-up 5 deviant
	F	Outside call communication of address dial-up 6 normal	Outside call communication of address dial-up 6 deviant
	G	Outside call communication of address dial-up 7 normal	Outside call communication of address dial-up 7 deviant
	DP	Outside call communication of address dial-up 8 normal	Outside call communication of address dial-up 8 deviant
2	A	Outside call communication of address dial-up 9 normal	Outside call communication of address dial-up 9 deviant

Tube Serial number	Tube passage marker	Meaning of tube passage “light”	Meaning of tube passage “No light”
	B	Outside call communication of address dial-up 10 normal	Outside call communication of address dial-up 10 deviant
	C	Outside call communication of address dial-up 11 normal	Outside call communication of address dial-up 11 deviant
	D	Outside call communication of address dial-up 12 normal	Outside call communication of address dial-up 12 deviant
	E	Outside call communication of address dial-up 13 normal	Outside call communication of address dial-up 13 deviant
	F	Outside call communication of address dial-up 14 normal	Outside call communication of address dial-up 14 deviant
	G	Outside call communication of address dial-up 15 normal	Outside call communication of address dial-up 15 deviant
	DP	Outside call communication of address dial-up 16 normal	Outside call communication of address dial-up 16 deviant
3	A	Outside call communication of address dial-up 17 normal	Outside call communication of address dial-up 17 deviant
	B	Outside call communication of address dial-up 18 normal	Outside call communication of address dial-up 18 deviant
	C	Outside call communication of address dial-up 19 normal	Outside call communication of address dial-up 19 deviant
	D	Outside call communication of address dial-up 20 normal	Outside call communication of address dial-up 20 deviant
	E	Outside call communication of	Outside call communication of address dial-up 21 deviant

Tube Serial number	Tube passage marker	Meaning of tube passage "light"	Meaning of tube passage "No light"
		address dial-up 21 normal	
	F	Outside call communication of address dial-up 22 normal	Outside call communication of address dial-up 22 deviant
	G	Outside call communication of address dial-up 23 normal	Outside call communication of address dial-up 23 deviant
	DP	Outside call communication of address dial-up 24 normal	Outside call communication of address dial-up 24 deviant
4	A	Outside call communication of address dial-up 25 normal	Outside call communication of address dial-up 25 deviant
	B	Outside call communication of address dial-up 26 normal	Outside call communication of address dial-up 26 deviant
	C	Outside call communication of address dial-up 27 normal	Outside call communication of address dial-up 27 deviant
	D	Outside call communication of address dial-up 28 normal	Outside call communication of address dial-up 28 deviant
	E	Outside call communication of address dial-up 29 normal	Outside call communication of address dial-up 29 deviant
	F	Outside call communication of address dial-up 30 normal	Outside call communication of address dial-up 30 deviant
	G	Outside call communication of address dial-up 31 normal	Outside call communication of address dial-up 31 deviant
	DP	Reserved	Reserved
5	0-9	CAN communication state, 0 stands for best state,9 for communication stop	

F5-34 F5-35	Terminal state display	Default		Min. Unit	
	Setting Range				

F5-34、F5-35 show the input and output terminal state. The keyboard tube order is 5, 4,3,2,1 from left to right. Every passage's definition is as follows:

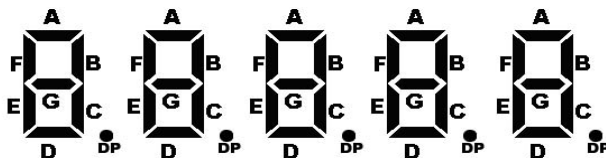

F5-34 expresses the state of the main control panel input or output terminal. Its meanings are listed in the following charts:

Tube Serial number	Tube passage marker	Tube passage meaning	Tube passage "light" meaning
	B	Up leveling	Up leveling signal availability
	C	Down leveling	Down leveling signal availability
	D	door zone signal	Door zone signal availability, at the leveling station
	E	Safety circuit feedback 1	Safety circuit pass
	F	Lock circuit feedback 1	Lock circuit pass
	G	Run output feedback 1	Contactor close state
	DP	Brake output feedback 1	Brake open state
2	A	Inspection signal	Inspection signal availability
	B	Inspection up signal	Inspection up signal availability
	C	Inspection down signal	Inspection down signal availability
	D	Fire signal	Fire signal availability
	E	Up end signal	Up end signal availability, at up end state
	F	Down end signal	Down end signal availability, at down end state
	G	Over load signal	Main control terminal over load

Tube Serial number	Tube passage marker	Tube passage meaning	Tube passage “light” meaning
			input availability
	DP	Full load signal	Main control terminal full load Input availability
3	A	NO.1 up force reducer signal	Signal availability, at the NO. 1 up force reducer area
	B	NO.1 down force reducer signal	Signal availability, at the NO. 1 down force reducer area
	C	NO.2 up force reducer signal	Signal availability, at the NO. 2 up force reducer area
	D	NO.2 down force reducer signal	Signal availability, at the NO. 2 down force reducer area
	E	NO.3 up force reducer signal	Signal availability, at the NO. 3 up force reducer area
	F	NO.3 down force reducer signal	Signal availability, at the NO. 3 down force reducer area
	G	Envelop door output feedback	Envelop door contactor close state
	DP	Motor overheated signal	Motor temperature is too high
4	A	Front light curtain	Front light curtain shut out
	B	Back light curtain	Back light curtain shut out
	C	Brake output feedback 2	Brake open state
	D	UPS input	Main control panel signal availability
	E	Lift-locking input	Main control panel signal availability
	F	Safety circuit feedback 2	Safety circuit pass
	G	Self-locking synchronous motor feedback	Self-locking contactor close
	DP	Door lock circuit feedback 2	Door lock circuit pass
5	A	Reserved	
	B	Run contactor output	Run contactor close

Tube Serial number	Tube passage marker	Tube passage meaning	Tube passage "light" meaning
	C	Brake contactor output	Brake open
	D	Envelop door contactor output	Envelop door contactor close
	E	Fire arrival land signal	Fire arrival land output

F5-34 expresses the state of the car top panel input or output terminal. Its meanings are listed in the following charts:

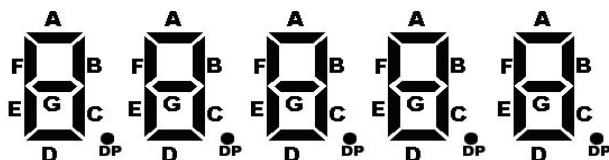

Tube Serial number	Tube passage marker	Tube passage meaning	Tube passage "light" meaning
1	A	Front light curtain input	Light curtain shut out
	B	Back light curtain input	Light curtain shut out
	C	Front door-open limit	Front door-open arrival
	D	Back door-open limit	Back door-open arrival
	E	Front door-close limit	Front door-close arrival
	F	Back door-close limit	Back door-close arrival
	G	Digital load 3 (full load)	Full load signal availability
	DP	Digital load 4 (over load)	Over load signal availability
2	A	Door-open button input	Signal availability
	B	Door-close button input	Signal availability
	C	Door-open delay button input	Signal availability
	D	Non-stop button input	Signal availability
	E	motorman button input	Signal availability
	F	vary direction button input	Signal availability
	G	separately running button input	Signal availability
	DP	Fire button input	Signal availability

Tube Serial number	Tube passage marker	Tube passage meaning	Tube passage “light” meaning
3	A	Front door-open	Front door-open output
	B	Front door-close	Front door-close output
	C	Door lock signal	Door lock pass in the present system
	D	Back door-open	Back door-open output
	E	Back door-close	Back door-close output
	F	Door lock signal	Door lock pass in the present system
	G	Up arrival gong	Up arrival gong output
	DP	Down arrival gong	Down arrival gong output
4	A	Door-open display output	Door-open display light
	B	Door-close display output	Door-close display light
	C	Door-open delay display output	Door-open delay display light
	D	Non-stop display output	Non-stop display light
	E	Reserved	
	F	Buzzer output	Buzzer output availability
	G	Reserved	
	DP	Energy saving	Fan/light output availability
5	A	System light curtain state 1	Light curtain shut out
	B	System light curtain state 2	Light curtain shut out
	C	External call lock lift input	Signal availability
	D	External call fire input	Signal availability
	E	Full load	Signal availability
	F	Over load	Signal availability

F5-36	Weighing input selection	Default	2	Min. Unit	1
	Setting Range	0、1、2、3			

0: Invalidation

1: Car top panel digital sampling.

2: Car top panel analog sampling.

3: Main control panel analog sampling.

F5-36 expresses signal channel of car weighing. Please exactly set this parameter before using weighing device.

6.7 F6 Group Lift Basic Parameters

Function code	Name	Default	Min. Unit	Setting Range
F6-00	The highest landing	9	1	F6-01~31
F6-01	The lowest landing	1	1	1~F6-00
F6-02	Parking landing	1	1	F6-01~F6-00

When the system not in using time is over the F9-00 setting value, lift can return parking landing by itself.

F6-03	Fire landing	Default	1	Min. Unit	1
	Setting Range	The lowest landing(F6-01)~The highest landing(F6-00)			

The lift will return to the landing when the system is in fire landing state.

F6-04	Stop landing	Default	1	Min. Unit	1
	Setting Range	The lowest landing(F6-01)~The highest landing(F6-00)			

When lift is in stopping state, it will return to this landing after completing control box command.

Function code	Name	Default	Min. Unit	Setting Range
F6-05	service floor 1	65535	1	0~65535
F6-06	service floor 2	65535	1	0~65535

F6-05 set what kind of floors command lift respond in floors 1~16. F6-06 set what kind of floors command lift respond in floors 17~31.

The setting way of F6-05 service floor 1:

The floor service is controlled by binary system number of 16 bit. The binary system number express the floor 1~16 from low bit to high bit, The setting relevant bit 1 express that lift responds to this floor's calling, and the

setting relevant bit 0 express that lift doesn't respond to this floor's calling. For example, floors in need of service are listed as follows:

Binary digit	Relevant floor	Service or not	Binary bit setting	Binary digit	Relevant floor	Service or not	Binary bit setting
Bit0	Floor 1	ON	1	Bit8	Floor 9	OFF	0
Bit1	Floor 2	OFF	0	Bit9	Floor 10	ON	1
Bit2	Floor 3	ON	1	Bit10	Floor 11	ON	1
Bit3	Floor 4	ON	1	Bit11	Floor 12	OFF	0
Bit4	Floor 5	ON	1	Bit12	Floor 13	ON	1
Bit5	Floor 6	ON	1	Bit13	Floor 14	ON	1
Bit6	Floor 7	ON	1	Bit14	Floor 15	ON	1
Bit7	Floor 8	OFF	0	Bit15	Floor 16	ON	1

The relevant binary digit setting is added in the list. The binary bit is 111101100111101, and the relevant algorithm number is 63101, so F6-05 should be set as 63101.

The setting way of F6-06 is the same with F6-05.

F6-07	Group control number	Default	1	Min. Unit	1
	Setting Range	1~8			

It can be used to choose lift number of group control:

- 1: Single lift running
- 2: 2 parallel lift running
- 3~8: Group control running (need the cooperation of group control panel MCTC-GCB-A)

F6-08	Lift number	Default	1	Min. Unit	1
	Setting Range	1~8			

It can set lift number when using group control. When F6-07 = 1, this function is useless.

- 1: Lift 1. At this time, the car top panel default is lift 1 which means the first three are set as OFF. This lift is the main lift of parallel, and it complete mostly parallel logic count.

2: Lift 2. At this time, the 1, 2 bit of car top panel switch S1 should be set as ON.

If it is in group control state, this function code should be set according to the actual coding of the lift. Details please refer to the instruction of <MCTC-GCB-A>.

F6-09	Parallel selection	Default	0	Min. Unit	0
	Setting Range	1~2			

Bit0: separated staying function selection

Bit1: Reserved

Bit2: CN2 parallel. There are two ways to parallel, BIT2=1 uses CN2 to parallel.

Note: When it doesn't use CN2 for parallel, please make sure the BIT2=0, otherwise, the controller may not run normally!

F6-13	Chucker-out floor	Default	1	Min. Unit	1
	Setting Range	The lowest landing(F6-01)~The highest landing(F6-00)			

It can set lift chucker-out floor. The chucker-out floor is availability from 10 at night to 6 at morning. Every time lift will run to the chucker-out floor firstly, then stop and open the door. Then it will run to the target floor, it can increase security. Using this function or not, please set through FE-32.

Function code	Name	Default	Min. Unit	Setting Range
F6-14	down-collective 1 start time	00: 00	00: 01	00: 00~23: 59
F6-15	down-collective 1 end time	00: 00	00: 01	00: 00~23: 59
F6-16	down-collective 2 start time	00: 00	00: 01	00: 00~23: 59
F6-17	down-collective 2 end time	00: 00	00: 01	00: 00~23: 59

These four function parameters define two groups of down-collective time segmentation. In this two time segmentation, lift will run according to the down-collective mode, which means it only responds to down external call.

Function code	Name	Default	Min. Unit	Setting Range
F6-18	Time-sharing service 1 start time	00: 00	00: 01	00: 00~23: 59
F6-19	Time-sharing service 1 end time	00: 00	00: 01	00: 00~23: 59
F6-20	Time-sharing service 1 floor 1	65535	1	0~65535
F6-21	Time-sharing service 1 floor 2	65535	1	0~65535
F6-22	Time-sharing service 2 start time	00: 00	00: 01	00: 00~23: 59
F6-23	Time-sharing service 2 end time	00: 00	00: 01	00: 00~23: 59
F6-24	Time-sharing service 2 floor 1	65535	1	0~65535
F6-25	Time-sharing service 2 floor 2	65535	1	0~65535

This group of function parameter defines two group time-sharing service time segmentation and service floor. In setting time, lift service floor is decided by relevant time-sharing service floor, and the floor parameters of F6-05,F6-06 is useless. For example, lift only responds to the time-sharing service 1 floor 1,2(F6-20,F6-21) in time-sharing service 1 (F6-18,F6-19),and don't perform F6-05,F6-06 parameters setting. When the time-sharing service 1 and time-sharing service 2 is superposable, the system perform the time-sharing service 1.The setting way of time-sharing service floor is the same with that of service floor F6-05.

Function code	Name	Default	Min. Unit	Setting Range
F6-26	Parallel fastigium 1 start time	00: 00	00: 01	00: 00~23: 59
F6-27	Parallel fastigium 1 end time	00: 00	00: 01	00: 00~23: 59

Function code	Name	Default	Min. Unit	Setting Range
F6-28	Parallel fastigium 1 floor	1	1	F6-00~F6-01
F6-29	Parallel fastigium 2 start time	00: 00	00: 01	00: 00~23: 59
F6-30	Parallel fastigium 2 end time	00: 00	00: 01	00: 00~23: 59
F6-31	Parallel fastigium 2 floor	1	1	F6-00~F6-01

This group of function parameters defines two group parallel fastigium time segmentation and floor., If car call over 3 from fastigium floor in parallel fastigium time segmentation, lift comes into fastigium service, at the moment , car call command is in availability at the time, and lift returns this floor at spare time.

6.8 F7 Group Testing Function Parameters

This group of parameters is especially enacted for lift adjustment. **So the setting of parameters won't be saved after power failure, and it will return to default.**

Before lift expedite running, please make sure well is free and every parameter is setting right. First, the lift should run slowly to the middle floor to prevent lift running reversal. Input multiple floor command after inputting one floor command. When completing adjustment, please check if this group of parameters is setting right.

Function code	Name	Default	Min. Unit	Setting Range
F7-00	Testing floor 1	0	1	0~F6-00
F7-01	Testing floor 2	0	1	0~F6-00
F7-02	Testing floor 3	0	1	0~F6-00
F7-03	Testing floor 4	0	1	0~60000

It can set the target floor when the lift is in adjusting or service. Its setting range is from 0~F6-00, but the commands of current floor and less than the floor F6-01 aren't administered.

0: Testing floor is invalidation. Testing floor 1 is the same with car call. Testing floor 2 is the same with landing up call. Testing floor 3 is the same

with landing down call. The command is durative availability until code set to 0 instead.

NICE 3000 can run at random. There are 5s in each running interval when simulating the daily running state. The times set by F7-03 are generated by the times of target floors occur at random. If the setting time is over 60000, the random running will keep on until the user sets 7-03 as 0.

F7-04	Landing call enable	Default	0	Min. Unit	1
	Setting Range	0、1			

0: Landing call allowable;

1: Landing call forbidden

F7-05	Door open enable	Default	0	Min. Unit	1
	Setting Range	0、1			

0: Door open allowable, door operator button useful;

1: Door open forbidden, door operator button unuseful and door don't automatically open.

F7-06	Over load function selection	Default	0	Min. Unit	1
	Setting Range	0、1			

0: Over load running forbidden;

1: Over load running allowable. When over load running is allowed, lift comes into over load state, light of over load lights, and lift doesn't respond to landing call, non-stop running to target floor. Please set 0 when it's in normal using.

F7-07	Limit enable	Default	0	Min. Unit	1
	Setting Range	0、1			

0: End switch availability;

1: End switch invalidation. Only use it when checking limit switch.



Note : This F7 group functions are used by persons who possess professional competency. Please pay more attention. The operator is in charge of the responsibilities. Please make sure that the setting of the F7 group parameters is 0.

6.9 F8 Group Reinforce Function Parameters

F8-00	Weighing self-tuning	Default	0%	Min. Unit	1%
	Setting Range	0~100%			

It means the weighing self-tuning setting. There are three steps of the weighing self-tuning:

- 1、Ensure **F8-01 setting is 0 and F5-36 choose 2 or 3**. This means that the system allow the weighing self- tuning.
- 2、Let lift stop at any floor, car is in non-load state, input F8-00 by setting 0,and press ENTER to input.
- 3、Put N% load into the car, set F8-00=n, and press ENTER to input. For example: put 100Kg heavy into lift of the rated load 1000Kg, and input F8-00=10.

After weighing self-tuning, the data of non-load and full load are written into F8-06 and F8-07.User can input data by hand based on the fact.



Note : please accord to this order. Otherwise the weighing self-tuning is invalidation.

F8-01	Preset torque selection	Default	0	Min. Unit	1
	Setting Range	0、 1			

0: Preset torque is invalidation, weighing self-tuning is allowable.

1: Torque bias is available.

When use preset torque bias function, the system can output torque with suited load, to assure comfortable feeling of the lift. But output torque is limited by Upper limit of torque(F2-08).When load torque is over the upper limit of torque setting, the system output torque is the upper limit of torque.

F8-02	Preset torque	Default	50.0%	Min. Unit	0.1%
-------	----------------------	---------	-------	-----------	------

	bias				
	Setting Range	0.0~100.0%			
F8-03	Drive gain	Default	0.60	Min. Unit	0.01
	Setting Range	0.00~2.00			
F8-04	Brake gain	Default	0.60	Min. Unit	0.01
	Setting Range	0.00~2.00			

If it is in full loading, the lift runs up, the motor is in drive running state; the lift runs down, the motor is in brake running state.

If it is in non-loading state, the lift runs up , the motor is in brake running state; the lift runs down, the motor is in drive running state.

The parameters for the pre-torque bias are actually the balance coefficient of the lift and it is also the percentage of the weight in the car and the rated weight when the car is in balance with the counterweight; Drive gain and brake gain are the pre-torque coefficients when the motor is in driving or brake running. The larger the compensation of the pre-torque in starting, the larger the gain will be in the same condition. The controller can identify the driving and brake state according to the signals of weight conductor, and then work out desirable torque compensation values.

When the system uses analog weighing, these group parameters are used for adjusting starting. Details of adjusting ways are as follows:

When motor is in driving state, If the lift rolls back when starts, increase F8-03; if the lift rushes to start, reduce F8-03.

When motor is in brake state, if the lift rolls back when starts, increase F8-04; if the lift rushes to start, reduce F8-04.

F8-05	Car load	Default	0	Min. Unit	1
	Setting Range	0~1023			

F8-05 is the read only parameter, reflecting the load state in car. The parameter is the NICE3000 sampling value of load. If F5-36 setting is less than 2, set F8-05=0. So F5-36 must be set right when using preset torque compensation function.

F8-06	Car no load setting	Default	0	Min. Unit	1
	Setting Range	0~1023			

F8-07	Car full load setting	Default	100	Min. Unit	1
	Setting Range	0~1023			

This group function codes can set the AD sampling value of analog when the car is in no load and full load condition.

**Note**

: If F8-06=F8-07, full load and over load is invalidation.

F8-08	Anti-nuisance function	Default	0	Min. Unit	1
	Setting Range	0、1			

0: This function forbidden;

1: Allowable. This function must work with weighing sensor or weighing switch. If the car order number is over the person number in car plus 3, the system clear up all orders, and each person according to 70 Kg.

F8-09	Power failure rescue speed	Default	0.050m/s	Min. Unit	0.001m/s
	Setting Range	0.000~0.100m/s			

When the lift is in the emergency state, it will run to leveling position in the speed. Please note that the speed shouldn't be too high in the rescue course, or it may affect the normal work of UPS. The speed is determined by the power of UPS.

F8-10	Power failure emergency rescue speed	Default	0	Min. Unit	1
	Setting Range	0: Motor isn't running 1: UPS power running 2: 48V batter power			

NICE 3000 supplies three ways of emergency rescue methods, details are in chapter 7.

F8-11	Car stopping torque output delay	Default	0.200(asynchronous) 0.600(sync)	Min. Unit	0.001
	Setting Range	0.200~1.500s			

After setting the commands of outputting brake close when the lift stops running, time for zero speed running depends on the brake.

6.10 F9 Group Time Parameters

F9-00	Free return main floor time	Default	10min	Min. Unit	1min
	Setting Range	0~240min			

It can set the time of back to the main floor when it is free. When lift doesn't receive car call, hall call or any other commands, the lift will return to the main floor.

0: This function is invalidation.

F9-01	Fan and light close time	Default	2min	Min. Unit	1min
	Setting Range	0~240min			

When lift is in automatic state, no run command, the system will cut off fan and light power after this setting time.

0: This function is invalidation.

F9-02	Longest interval time of running in the floor	Default	45s	Min. Unit	1s
	Setting Range	0~45s			

When lift running time is over the F9-02 setting time at border upon floors (There's no leveling signal then), lift will come into protection. When this parameter setting is less than 3s, this function is invalidation.

Function code	Name	Default	Min. Unit	Setting Range
F9-03	Clock: year	2005	1	2000~2100
F9-04	Clock: month	3	1	1~12
F9-05	Clock: day	1	1	1~31
F9-06	Clock: hour	0	1	0~23
F9-07	Clock: minute	0	1	0~59

Those parameters mentioned above are the interior time of NICE3000. This clock can count time when there's power failure. Nice3000 can complete

many special functions with time by this clock such as fastigium service, etc. So users should set this parameter right by actual time when first electrify.

Function code	Name	Setting Range	Default	Min. Unit
F9-09	Accumulative working time	0~65535h	0	1
F9-11	RUN times high bit	0~9999	1	1
F9-12	RUN times low bit	0~9999	0	1

They are total accumulative actual lift working time and running times. These function parameters are read only and user isn't allowed to amend them. Lift accumulative run times = run times high bit ×10000 + run times low bit.

6.11 FA Group Keyboard Setting Parameters

FA-00	Small keyboard display selection	Default	0	Min. Unit	1
	Setting Range	0: Reversal display, physics floor 1: Positive display, physics floor 2: Reversal display, external call data 3: Positive display, external call data			

There are 3 bit LED displays at NICE3000 main control panel. User can change its display direction by changing this function code; thereby it's convenient to control the design of the cabinet. No matter how to fix the main control panel, you can look through it easily. When the setting is 0 or 1, small keyboard displaying data is the number of physics floor. When the setting is 2 or 3, small keyboard displaying data is external call data.

FA-01	Run display 1	Default	65535	Min. Unit	1
	Setting Range	0~65535			

This function code is made up of a binary number with 16 emic that display 16 kinds of running state parameters. Each parameter is controlled by one binary number, "1" expresses that display this parameter, "0" expresses that don't display this parameter. If want to display parameter as the following list, relevant binary number should be set as follows:

Binary bit	Parameter	Display or not	Binary bit setting	Binary bit	Parameter	Display or not	Binary bit setting
Bit0	Running speed	Display	1	Bit8	Output terminal	Not display	0
Bit1	Rated speed	Display	1	Bit9	Currently floor	Not display	0
Bit2	Bus voltage	Display	1	Bit10	Currently station	Not display	0
Bit3	Output voltage	Not display	0	Bit11	Car load	Display	1
Bit4	Output current	Display	1	Bit12	Car top input state	Not display	0
Bit5	Output frequency	Display	1	Bit13	Car top output state	Not display	0
Bit6	Input terminal low bit	Not display	0	Bit14	System state	Display	1
Bit7	Input terminal high bit	Not display	0	Bit15	Preset torque current	Not display	0

The setting binary number is 0100100000110111, the corresponding algorithm number is 18487, and FA-01 should be set as 18487. These displaying parameter can be switched by shift key in control keyboard.

FA-02	Stop display	Default	65535	Min. Unit	1
	Setting Range	0~65535			

This function code is made up of binary numbers with 16 emic that displays 12 kinds of stopping state parameters. The displaying parameters can be switched by shift key on the control keyboard in the following list. The setting way is the same with FA-01.

Bit0	Rated speed	Bit6	Current station
Bit1	Bus voltage	Bit7	Car load
Bit2	Input terminal low bit	Bit8	Rated lift slowdown distance
Bit3	Input terminal high bit	Bit9	Car top input state
Bit4	Output terminal	Bit10	Car top output state
Bit5	Current floor	Bit11	System state

The stopping and running parameters are useful and important reference for the technician when adjusting the lift. The specific meaning of each variable is described as follows:

Running speed: is the actual speed when the lift is running. It's the feedback speed of rotation encoder whose maximum value is the fastest speed (F0-03) of the lift, with the unit m/s.

Setting speed: is the speed of NICE3000 when it's running. It's gained by the theoretical calculations with the unit m/s.

Bus voltage: is the value of DC bus voltage with the unit V.

Output voltage: is the valid value of equivalent voltage when NICE3000 outputs PWM wave form, with the unit V.

Output current: is the valid value of the actual current when NICE3000 drive motor is running, with the unit A.

Output frequency: is the actual frequency when the motor is running with the unit Hz. This parameter is fixed corresponding with the running speed.

Input terminal low bit: It shows the meaning of the terminals by bit. If the bit is "1", the signal is valid. There is 16 bit whose meanings are as follows:

Binary bit	Meaning	Binary bit	Meaning
Bit0	Reserved	Bit8	Inspection signal
Bit1	Up leveling signal	Bit9	Inspection up signal
Bit2	Down leveling signal	Bit10	Inspection down signal
Bit3	Door zone signal	Bit11	Fire signal
Bit4	Safety circuit feedback1	Bit12	Up end signal
Bit5	Lock circuit feedback 1	Bit13	Down end signal
Bit6	Run output feedback 1	Bit14	Over load signal
Bit7	Brake output feedback 1	Bit15	Full load signal

Input terminal high bit: It shows the meaning of the terminals by bit. If the bit is "1", the signal is valid. There is 16 bit whose meanings are as follows:

Binary bit	Meaning	Binary bit	Meaning
Bit0	NO.1 up force reducer signal	Bit8	Front light curtain
Bit1	NO.1 down force reducer signal	Bit9	Back light curtain
Bit2	NO.2 up force reducer signal	Bit10	Brake output feedback 2
Bit3	NO.2 down force reducer signal	Bit11	UPS input
Bit4	NO.3 up force reducer signal	Bit12	Lift-locking input
Bit5	NO.3 down force reducer signal	Bit13	Safety circuit feedback 2
Bit6	Envelope door output feedback	Bit14	synchronous motor Self-locking feedback
Bit7	Motor overheated signal	Bit15	Door lock circuit feedback 2

Input terminal: It shows the meaning of the terminals by bit. If the bit is “1”, the signal is valid. There is 16 bit whose meanings are as follows:

Binary bit	Meaning	Binary bit	Meaning
Bit0	Reserved	Bit8	Back door close
Bit1	Run contactor output	Bit9	Contactor normal
Bit2	Brake contactor output	Bit10	Fault state
Bit3	Envelop door contactor output	Bit11	System in running state
Bit4	Fire arrival land signal	Bit12	Reserved
Bit5	Front door open	Bit13	Reserved
Bit6	Front door close	Bit14	Reserved
Bit7	Back door open	Bit15	Emergency leveling buzzer output

Current floor: the information for physic floor where the lift stays when it's running. Its content is the same with F4-01.

Current station: It reflects the absolute position of the car to the leveling plate of the first floor. The unit is M.

Car load: according to the information from the sensor, it's the percentage of car load to rated load, with the unit %.

Car top input state: It shows the meaning by bit. If the bit is “1”, the signal is valid. There is 16 bit whose meanings are as follows:

Binary bit	Meaning	Binary bit	Meaning
Bit0	Front light curtain input	Bit8	Door-open button input
Bit1	Back light curtain input	Bit9	Door-close button input
Bit2	Front door-open arrival	Bit10	Door-open delay button input
Bit3	Back door-open arrival	Bit11	Non-stop button input
Bit4	Front door-close arrival	Bit12	Motorman button input
Bit5	Back door-close arrival	Bit13	Vary direction button input
Bit6	Digital load 3 (full load)	Bit14	Separately running button input
Bit7	Digital load 4 (over load)	Bit15	Fire button input

Car top output state: It shows the meaning by bit. If the bit is “1”, the signal is valid. There is 16 bit whose meanings are as follows:

Binary bit	Meaning	Binary bit	Meaning
Bit0	Front door-open output	Bit8	Door-open button display
Bit1	Front door-close output	Bit9	Door-close button display
Bit2	Door lock signal	Bit10	Door-open delay button display
Bit3	Back door-open output	Bit11	Non-stop button display
Bit4	Back door-close output	Bit12	Motorman signal

Binary bit	Meaning	Binary bit	Meaning
Bit5	Door lock signal	Bit13	Vary direction signal
Bit6	Up arrival gong	Bit14	Separately running signal
Bit7	Down arrival gong	Bit15	Fireman operation signal

System state: It shows the meaning by bit. If the bit is “1”, the signal is valid. There is 16 bit whose meanings are as follows:

Binary bit	Meaning	Binary bit	Meaning
Bit0	System light curtain state 1	Bit8	Car state: 1: door open; 2: door open keeping; 3: door close 4: door open arrival 5: running
Bit1	System light curtain state 2	Bit9	
Bit2	External call lock lift	Bit10	
Bit3	External call fire	Bit11	
Bit4	Lift state: 0: inspection; 1:well self-learning; 3:fire arrival main floor; 4:firemen; 6: motorman ; 7:normal	Bit12	
Bit5		Bit13	System over load
Bit6		Bit14	Reserved
Bit7		Bit15	Reserved

Pre-torque current; it reflects the percentage of compensational pre-torque current to the rated current when the lift starts to run, with the unit %.

FA-03	Pulse wheel encoder currently angle	Default	0.0°	Min. Unit	0.1°
	Setting Range	0.0~360.0°			

It displays the current factual angle of the encoder. User cannot amend it.

Function code	Name	Setting Range	Default	Min. Unit
FA-04	Software edition 1(FK)	0~65535	0	1
FA-05	Software edition 2(ZK)	0~65535	0	1

FA-06	Software edition 3(DSP)	0~65535	0	1
FA-07	Radiator temperature	0~100℃	0	1℃

It displays the software edition NICE3000 is using. FA-07 displays radiator's current temperature.

6.12 FB Group Door Function Parameters

FB-00	Door machine number	Default	1	Min. Unit	1
	Setting Range	1~2			

It can set the number of door machine. User can set this function parameter by actual using number of door machine.

FB-02	Front door service floor 1	Default	65535	Min. Unit	1
	Setting Range	0~65535 (set 1~16 floor)			

This function code is made up of binary numbers with 16 emic that control those floors allowing front door to open normally within floor 1 to floor 16. Every floor door is controlled by one binary number.

1: Relevant floor's front door can be open.

0: Forbidden relevant floor's front door open.

Its setting way is the same with F6-05; details are shown in section 6.7.

Notice: this parameter shouldn't clash with F6-05 and F6-06 when user's setting! It's required to ensure that door machine's service floor is the system service floor.

FB-03	Front door service floor 2	Default	65535	Min. Unit	1
	Setting Range	0~65535 (set 17~31 floor)			

This function code is made up of binary numbers with 16 emic that control those floors allowing front door to open normally within floor 17 to floor 31. Every floor door is controlled by one binary number.

1: Relevant floor's front door can be open.

0: Forbidden relevant floor's front door open.

Its setting way is the same with F6-05; details are shown in section 6.7.

FB-04	Back door service floor 1	Default	65535	Min. Unit	1
	Setting Range	0~65535 (set 1~16 floor)			

This function code is made up of binary numbers with 16 emic that control those floors allowing back door to open normally within floor 1 to floor 16. Every floor door is controlled by one binary number.

1: Relevant floor's back door can be open.

0: Forbidden relevant floor's back door open.

Its setting way is the same with F6-05; details are shown in section 6.7. The function parameter can only be valid when the door number of FB-01 is 2.

FB-05	Back door service floor 2	Default	65535	Min. Unit	1
	Setting Range	0~65535 (set floor 17~31)			

This function code is made up of binary numbers with 16 emic that control those floors allowing back door to open normally within floor 17 to floor 31. Every floor door is controlled by one binary number.

1: Relevant floor's back door can open.

0: Forbidden relevant floor's back door open.

Its setting way is the same with F6-05; details are shown in section 6.7. The function parameter can only be valid when the door number of FB-01 is 2.

FB-06	Open door time protection	Default	10s	Min. Unit	1s
	Setting Range	5~99s			
FB-08	Close door time protection	Default	15s	Min. Unit	1s
	Setting Range	5~99s			

The open/close door time protection means: When the system outputs open/close door command but doesn't receive open/close door arrival feedback after the time of FB-06, the door machine turns to close/open door at once. This is once for door open and close. When it reaches the

times FB-09 (open/close door times) setting of open/close door, the system will warn E48 door open error or E 49 door close error.

FB-09	Door open/close times	Default	0	Min. Unit	1
	Setting Range	0~20			

This function code sets the door open and close times after the FB-06/FB-08 setting time. When lift on-off door times is over this setting value, lift will warn E48 error or E49 error.

If FB-09 = 0, door on-off protection is invalidation. The system will not stop opening/closing door until it receives door open/close arrival signal.

FB-10	Running main floor door state	Default	0	Min. Unit	1
	Setting Range	0~1			

FB-10 is the function for lift waiting when the main floor door opens.

0: open the door normally

1: door open waiting

FB-11	Time keeping for external call to open door	Default	5s	Min. Unit	1s
	Setting Range	1~30s (corresponding to external call)			

It's the length of time waiting when there's external call command but no operation box command. If there's closing door command inputting, it responds to the command immediately.

FB-12	Time keeping for internal call to open door	Default	3s	Min. Unit	1s
	Setting Range	1~30s (corresponding to internal call command)			

It's the length of time waiting when there's operation box command. If there's closing door command inputting, it responds to the command immediately.

FB-13	Time keeping for	Default	10s	Min. Unit	1s
--------------	-------------------------	---------	-----	-----------	----

		Bit2: Over-adjusting function selection 0: Over-adjusting function valid 1: Over-adjusting function invalidation Bit3: E053 add door-close arrival judgment 0:no new method 1:old method + old method Bit4: door-closing arrival judge light curtain 0:no re-opening 1:re-open the door Bit5: DSP communication judgment 0:wire broken check 1:no check Bit6: new method for parallel door block 0: use mew method 1: resume to 745 program Bit7:reveling over-speed check 0:check 1:no check
--	--	--

This function parameter can set the over load protection and output phase-failure protection, and it's mainly used for factory detection. Users needn't set it.

FC-02	Overload protection coefficient	Default	1.00	Min. Unit	0.01
	Setting Range	0.50~10.00			

This function code's referred value is overloading current. When the system detects that the output current arrives to the FC-02×motor's rated current and last out the special time, the system will output E11 motor overload.

FC-03	Overload pre-warning coefficient	Default	80%	Min. Unit	1%
	Setting Range	50~100%			

This function code referred value is motor's overload current. When the system detects that the output current arrives to the FC-03×motor rated current and last out the special time, the system will output pre-warning

signal.

FC-04	Error self-resetting times	Default	0	Min. Unit	1
	Setting Range	0~10			

This function code can set the system self-resetting times when there's system error. If the system error times are over this value, the system will stay and wait for service.

0: It means that there's no self-resetting function in the system.

FC-05	Interval time for resetting	Default	5s	Min. Unit	1s
	Setting Range	2~20s			

The interval time between the beginning of the fault and the automatic fault resetting, and the waiting time between two fault automatically reset.

Function code	Name	Setting Range	Default	Min. Unit
FC-06	First error information	0~3199	0	1
FC-07	First error month and day	0~1231	0	1
FC-08	Second error information	0~3199	0	1
FC-09	Second error month and day	0~1231	0	1
⋮	⋮	⋮	⋮	⋮
FC-24	Tenth error information	0~3199	0	1
FC-25	Tenth error month and day	0~1231	0	1
FC-26	Latest error information	0~3199	0	1
FC-27	Latest error speed	0.000~3.000m/s	0.000	0.001m/s
FC-28	Latest error current	0.0~999.9A	0.0	0.1A
FC-29	Latest error bus voltage	0~999V	0	1V
FC-30	Latest error month and	0~1231	0	1

Function code	Name	Setting Range	Default	Min. Unit
	day			
FC-31	Latest error time	0~2359	0	1

This group function codes can note the latest 11 times error code, floor and time. The error information is made up of 4 bit, the higher 2 bit mean the car stopping floor when error occurs, and the lower 2 bit mean error code. For example: If the latest error information noted by FC-26 is 1035, it means that the latest error code is Err35 and the latest error floor is the tenth floor. FC-28 ~ FC-31 record the outputting current, bus voltage and the idiographic time when the latest error happens. The error's type and meaning refers to chapter 8.

6.14 FD Group Communication Parameters

Function code	Name	Setting Range	Default	Min. Unit
FD-00	Baud rate setting	0: 300bps 1: 600bps 2: 1200bps 3: 2400bps 4: 4800bps 5: 9600bps 6: 19200bps 7: 38400bps	5	1
FD-01	Data format	0: No check-out 1: Even check-out 2: Odd check-out	0	1
FD-02	Local address	0 ~ 127, 0: Broadcasting address	1	1
FD-03	Responding delay	0~20ms	10ms	1ms
FD-04	Communication delaying time	0.0 ~ 60.0s , 0.0s : invalidation	0.0s	0.1s

This group function codes can set NICE3000 RS232 Serial communication parameter for up bit motor monitoring software communication. FD-00 sets Serial communication baud rate, FD-01 sets Serial communication data frames format, and FD-02 sets the local address of controller. These parameters' setting must be the same with the Serial communication

parameters of controller so that they can communicate normally. FD-03 sets the delaying time of controller transmitting data by the Serial port. FD-04 sets the overtime of the Serial port communication, and the time of frame data transmitted must be within the time of FD-04 setting. Otherwise communication error may occur.

6.15 FE Group Lift Function Setting Parameters

FE-00	Collective selective mode	Default	0	Min. Unit	1
	Setting Range	0、1、2			

0: Full selective, lift responds to up call and down call.

1: Down selective, lift only responds to hall down call and doesn't respond to hall up call.

2: Up selective, lift only responds to hall up call and doesn't respond to hall down call.

Function code	Name	Setting Range	Min. Unit	Default
FE-01	Floor 1 corresponding display	0000~1999	1	1901
FE-02	Floor 2 corresponding display		1	1902
FE-03	Floor 3 corresponding display		1	1903
FE-04	Floor 4 corresponding display		1	1904
FE-05	Floor 5 corresponding display		1	1905
FE-06	Floor 6 corresponding display		1	1906
FE-07	Floor 7 corresponding display		1	1907
FE-08	Floor 8 corresponding display		1	1908
FE-09	Floor 9 corresponding display		1	1909
FE-10	Floor 10 corresponding		1	0100

Function code	Name	Setting Range	Min. Unit	Default
	display			
FE-11	Floor 11 corresponding display		1	0101
FE-12	Floor 12 corresponding display		1	0102
FE-13	Floor 13 corresponding display		1	0103
FE-14	Floor 14 corresponding display		1	0104
FE-15	Floor 15 corresponding display		1	0105
FE-16	Floor 16 corresponding display		1	0106
FE-17	Floor 17 corresponding display		1	0107
FE-18	Floor 18 corresponding display		1	0108
FE-19	Floor 19 corresponding display		1	0109
FE-20	Floor 20 corresponding display		1	0200
FE-21	Floor 21 corresponding display		1	0201
FE-22	Floor 22 corresponding display		1	0202
FE-23	Floor 23 corresponding display		1	0203
FE-24	Floor 24 corresponding display		1	0204
FE-25	Floor 25 corresponding display		1	0205
FE-26	Floor 26 corresponding display		1	0206
FE-27	Floor 27 corresponding display		1	0207
FE-28	Floor 28 corresponding		1	0208

Function code	Name	Setting Range	Min. Unit	Default
	display			
FE-29	Floor 29 corresponding display		1	0209
FE-30	Floor 30 corresponding display		1	0300
FE-31	Floor 31 corresponding display (double door plural selection hall call setting)		1	0301

This group function code can set hall displaying content of the opposite floor. Its value is made up of 4 bit. The higher 2 bit express the tens digit of floor displaying, and the lower 2 bit express the first rank of floor displaying. The higher 2 bit's and lower 2 bit's meaning are as follows:

Code	Display	Code	Display
00	0	10	A
01	1	11	B
02	2	12	G
03	3	13	H
04	4	14	L
05	5	15	M
06	6	16	P
07	7	17	R
08	8	18	-
09	9	19	No display
20	12	21	13
22	23	≥22	No display

For example:

Actual floor	Required displaying	Higher 2 bit setting	Lower 2 bit setting	Corresponding function code setting
Basement 1	-1	'-' corresponding code 18	'1' corresponding code 01	1801
Floor 1	G	No display,	'G' corresponding	1912

Actual floor	Required displaying	Higher 2 bit setting	Lower 2 bit setting	Corresponding function code setting
		corresponding code19	code 12	
Floor 2	2	No display, corresponding code 19	'2' corresponding code 02	1902
Floor 14	13A	'13', corresponding code 21	'A' corresponding code 10	2110

FE-31 can't only set the floor 31 hall displaying content, but also can express the opposite door plural selection hall call function. When FE-31 setting value isn't less than 10, it expresses the floor 31 hall corresponding displaying content. If the highest floor is less than floor 29(F6-00<29) when FE-31 setting value is less than 10, it expresses that one floor below floor 10 is double door and double hall displaying. Set the on-off switch address of back door hall call panel as 31, the system can differentiate front door and back door. At this time, FE-31 setting parameter expresses the corresponding floor of the hall call panel on-off switch setting31.

For example: the highest floor is floor 10, the lowest floor is floor 1, and floor 2 is the double door with hall call displaying panel and button. At this time, set FE-31 as 2. In this way, the two display panels of on-off switch setting address 31 and 2 both can be used for the hall call displaying panel of floor 2. But in this condition, the two hall calls have the same calling function, can't control front door and back door all by itself.

FE-32	Lift factory function selection1	Default	35843	Min. Unit	1
	Setting Range	0~65535			

This function code sets the lift factory required function. Each function is controlled by one binary number,"1" expresses this function allowable,"0" expresses this function forbidden. If lift needs motorman function, fire return function, inspection automatic close, car call miss-delete, door lock jump-out inspection function valid while other function invalidation, the binary system setting is as follows:

Binary bit	Function	Binary setting	Binary bit	Function	Binary setting
Bit0	Motorman	1	Bit8	Time-sharing service floor	0
Bit1	Fire return to main floor	1	Bit9	Independent running	0
Bit2	Re-leveling	0	Bit10	Inspection automatic close door	1
Bit3	Pre-opening	0	Bit11	Car call miss delete	1
Bit4	Hall call conglutination disposal	0	Bit12	Hall call miss delete	0
Bit5	Night security floor	0	Bit13	Emergency auto-running car	0
Bit6	Down collective selective fastigium service	0	Bit14	Emergency self-rescue overtime protection	0
Bit7	Fastigium service	0	Bit15	Door lock jump-out test	1

The setting binary number is 1000110000000011; the corresponding algorithm number is 35843, so FA-01 should be set as 35843.

FE-33	Lift factory function selection2	Default	32	Min. Unit	1
	Setting Range	0~65535			

Factory default is forced reducer conglutination inspection function, which is listed in the following chart.

Binary bit	Function	Binary setting	Binary bit	Function	Binary setting
Bit0	Reserved	1	Bit8	N.C. output of enclosed star contactor	0
Bit1	Door opening	1	Bit9	Reversal leveling	0

Binary bit	Function	Binary setting	Binary bit	Function	Binary setting
	arrival keep open			immediate stopping	
Bit2	No output door closing signal when running	0	Bit10	Weighing analogue input uses 10 bit AD sampling	1
Bit3	Door close Maintenance detect door close arrival	0	Bit11	No door closing command after light-off in the car	1
Bit4	Contacteur conglutination recover automatically	0	Bit12	No stopping function selection in the Reversal leveling of no service floor	0
Bit5	Force reducer switch conglutination inspection	0	Bit13	Fast speed lift's protection function selection	0
Bit6	Synchronous motor enclosed star contactor outputs when it stops	0	Bit14	No direction display when there's no call after the lift stops	0
Bit7	Reserved	0	Bit15	Open-through door separately control	1

In order to make it convenient for lift factories to do the value added setting, several functions of NICE 3000 is chosen through FE-32, FE-33. The functions mentioned above are described as follows:

Motorman: There will be no motorman function if there's selection.

Fire return to main floor: After this selection, use can get into the fire return to the main floor function through the floor display panel or main control panel terminal (fire signal). In this condition, the lift will stop at the nearest floor without opening the door if it's running at that moment. Then,

if there's fireman signal inputting, the lift will get into fireman running.

Re-leveling: The car load is changing dramatically when the car door opens, it will cause the car cage of high floor lift or heavy load lift higher or lower than the sill. After choosing this function, the lift will re-leveling run with quite low speed when the door is open. The function requires the cooperation of the external enclosed door contactor, and it needs three leveling contactors (up, down leveling, door zone).

Pre-opening: When the lift is running normally, the speed is slower than 0.1m/s in the stopping course, and the door zone signal is valid, it jumps out the door lock signal through envelop door contactor, and pre-opens the door to make the most efficiency.

Hall call conglutination disposal: Generally, if the hall call button is conglutination, it may cause the lift repeating opening the door in the current floor. After using this function, Nice 3000 can identify the information of the hall call button automatically. If any abnormal is found, it will disposal the button in self-motion, so it won't affect the using of the lift.

Night security floor, down collective selective fastigium service, fastigium service and time-sharing service floor function: refer to the parameter introduction in F6 group.

Brake output pre-run output

For special asynchronous master machine use, special treatment for time sequence; invalid for sync machine.

Independent running: It's not in parallel (group control), and it gets into the independent running condition through the independent running switch in the car cage. At the moment, the lift doesn't respond to the hall call and the door operation is the same with that in motorman condition, which means there's no automatic door closing and it opens the door automatically if it fails to complete closing the door. If it's in the parallel (group control) state, the system will get off the parallel (group control) in self-motion.

Maintenance automatic close door: When the machine room is in the maintenance operation, if the car cage's door isn't closed, it will cause the lift's door lock block and the lift can't travel. If choose this function, press UP and DOWN button, the lift will close the door automatically when it's in maintenance. There's no close door signal outputting if you don't press UP

and DOWN button.

Car call miss delete: If you are ready to delete the registered car call command, press the call button twice continuously (interval time around 0.5s), the system will cancel this call. However, if the car call has been locked by the lift, you can't delete this call command.

Hall call miss delete: If you are ready to delete the registered hall call command, press the call button twice continuously (interval time around 0.5s), the system will cancel this call.

Emergency auto-running car: While it uses permanent-magnet synchronous motor, the lift can fulfill auto-running car through the enclosed star contactor when there's power failure and it opens the door when it slides to the leveling position. This function enables the economical emergency rescue realize.

Emergency self-rescue overtime protection: If the car cage is in balance load or the rescue driving power's capacity is not adequate, it will cause long emergency rescue time and even dangers occur. This function enables to stop rescuing when auto-running car rescue time is over 100s, and rescue driving time is over 50s.

Door lock jump-out test: If door lock jump-out is found after door open arrival, the system alarms E53 when the lift is running in normal condition.

Door opening arrival keep open: If choose this function, the lift keep outputting open door signal when there's door opening arrival.

No output door closing signal when running: If choose this function, the lift doesn't output close door signal when it is running.

Door close maintenance detects door close arrival: If choose this function, the system can judge the door close arrival signal in the door close maintenance function. If not, the system can only judge the door close arrival situation through door lock signal.

Contactor conglutination recover automatically: Detect the brake, and traveling contactors' feedback contacts, alarm E36, E37 if the contacts are deviant, and it can't recover automatically. If the two errors occur, this function enables to recover automatically no more than three times as long as these errors disappear.

Force reducer switch conglutination inspection: This function enables

to monitor the force reducer switch all the time when the lift is running. If conglutination is detected, it's forced to reduce.

Synchronous motor enclosed star contactor outputs when it stops:

Synchronous motor closed star contactor can assure that there won't be fast speed slide running even when the brake doesn't work. Under this function, NICE 3000 output terminal selection 12 (synchronous motor closed star output) can output in self-motion when the lift stops. If choose the feedback contact input (some function codes set as 30 or 62 in function codes F5-01~F5-24), NICE 3000 will monitor the feedback contact in the application of synchronous motor, and alarm E29 if anything deviant occur.

N.C. types of enclosed star contactor: In synchronous motor, closed star contactor control usually adapt N.C. switch.

Weighing analog input uses 10 bit AD sampling:

Weighing analogue input uses 10 bit AD sampling: "0", weighing analogue uses 8 bit AD sampling; "1", weighing analogue uses 10 bit AD sampling. After select this function, it needs anew weighing self-tuning.

No close door command output when the lights in the car are off:

Under saving energy state, the lift doesn't need to continuously output close door command in case that the door machine will work for a long time.

No stopping function selection in the non-service floor reversal leveling:

On the spot of the lift's application, part of the floors may not be service floors for some reason, and it requires that the lift can't stop at these floors in the course back to the level. User can select through BIT12 of FE-33, if the BIT12 is 1, NICE 3000 control system will judge whether the current floor is service floor or not in the course back to the level, and it can only stop at the service floor.

Fast speed elevator's protection function selection:

At present, synchronous tractive motor's fast speed elevators (over than 2.5m/s) are more and more widely used. For the fast speed application, NICE 3000 adds special protection function to protect from the accidents (such as rush to the top) occurring. Don't use the function while the speed is lower than 2.5m/s.

No direction displaying when lift stops and no calls:

The function should be selected through BIT14 of FE-33. After selection, NICE 3000 will

detect if there are other calls when the lift stops each time. If not, it will immediately cancel the direction displaying and won't display the direction.

Open-through door independent control including the following functions:

A. Open door delaying: After using this function, the lift won't close the door, when press the open door delaying button. It keeps open and doesn't need to set the time. If there's no press on the open door delaying button, the close door function is the same with the standard close door function.

B. Door1 and Door2 control: Increase the JP16 function of MCTC-CCB-A, JP16 is as door1 and door2's control switch. The switch is operated by the button, and it will do door1 and door2 switch after each pressing. When firstly power on, it is considered as door1 control. If there's only one door in this floor, the door1 and door2 opening is invalidation; if there are two doors, select through this button, but it won't open the two doors synchronously. Each press on the button means once door1 and door2 control switch, and there are more than 3s interval time.

C. External call for current floor opening the door: After the lift close the door, the current floor has the re-opening function.

D. Open the door when stops: When the lift stops, it's judged according to several conditions: If there's only single side external call, the lift stops and opens the door that is calling; If there are two sides external call, the lift stops and judges to open the door according to door1 and door2 control switch; If there's no external call, but internal call, the lift judges to open the door according to door1 and door2 control switch when the life stops;

E. After selection of this function, the highest floor of the fifteenth floor (physical floor). External call address 1~15 corresponds to Floor 1~15 door 1 external call, and external call address 17~31 corresponds to Floor 17~31 door 2 external call.

6.16 FE Group Factory Parameters (Reserved)

6.17 FP Group User Parameters

FP-00	User password	Default	0	Min. Unit	1
	Setting Range	0~65535			

Set any number but zero, the password protection function is valid.

00000: Clear the password value setting by previous user, and make the password protection function invalidation.

After the user password is set and valid, when it gets into the parameter setting state, you can't check or modify the parameters if the password is not correct. Details of password setting measures are listed in section 4.2.4.

Please firmly remember your setting password, and contact with the factory if you miss-set or forget.

FP-01	Parameter resetting	Default	0	Min. Unit	1
	Setting Range	0、1、2			

0: None;

1: Return to factory parameters. All the values of other function parameters but F1 group function code will return to factory parameters. Please operate with caution!

2: Clear memory parameter. It will clear all the recorded error information.

FP-02	User setting examination	Default	0	Min. Unit	1
	Setting Range	0、1			

0: Invalidation

1: Valid, and the operation keyboard only displays those parameters different from factory setting.

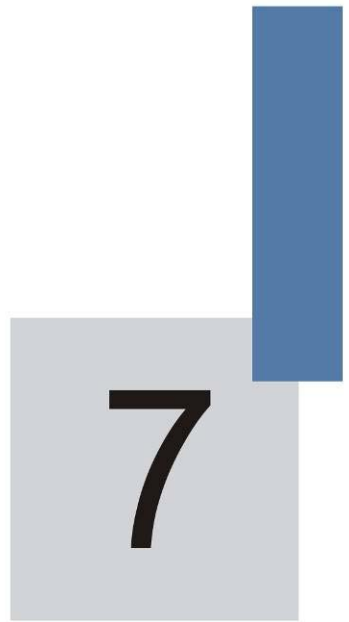

System typical application and adjustment

Chapter 7 System typical application and adjustment

7.1 Lift Adjustment



When the lift is in adjusting state, please keep no person in the well and in the car! Otherwise, there may be serious accident.

In order to be convenient for adjust, this chapter was wrote according to the normal sequence of lift adjustment. As the periphery circuit and machine installed are finished fully, you can complete the lift basic adjust.

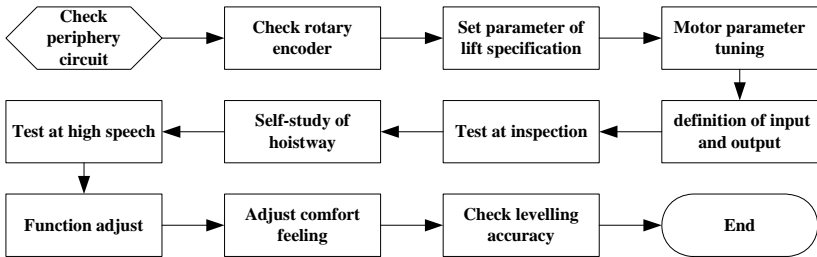

Fig. 7-1 adjusting process

7.1.1 Check before testing on low speed

The lift gets into the adjusting step after the installation. The correct adjusting is a guarantee for lift's normal safe running. Before the adjusting on the lift, it needs to check whether each part is allowed to adjust in order to assure the safety at site. At least two staff are required in adjusting. And cut off the power immediately if abnormal situation occurs.

- 1) Mechanical and electrical wiring inspection on the spot

Check the external wiring before the system is power-on to make sure of parts and personal safety.

- a) Check if the parts' types are matched.
- b) Safety circuit is passed through.
- c) Door lock circuit is passed through and work reliably.
- d) Well is smooth and no one in the car, and possess the conditions suitable for the lift safety running.
- e) Well connected to the ground.
- f) Correct external wiring according to the factory blueprint.
- g) Each switch works normally, and operates reliably.
- h) Check the circuit's interval resistance, and check whether short circuit to the ground exists.
- i) Confirm the lift is in inspection state.
- j) Mechanical parts are installed to the right position, and it won't cause equipment damages or personal injuries.

2) Encoder inspection

Encoder feedback pulse signal is an important assurance for the system to fulfill accurate control. It needs special inspection before adjusting.

- a) Encoder installation is stable and wiring is reliable.
- b) Encoder signal wiring and strong power circuit are set in separated grooves to prevent from interference.
- c) It would be better to introduce the encoder wiring from the encoder

into the control panel. If the wiring is not long enough and need connected to the ground, the extension part should use shielded wire and the connection with the encoder's original wire should be better welded joint with electric iron.

d) Encoder's shielded level requires controller's one terminal connect to the ground reliably.

e) Detailed wiring chart of encoder refers to section 3.2.3.

3) Check power

Check user's power before the system is power on.

The user's power voltage between each phase should be within $380V \pm 15\%$, and the unbalance degree should not be over 3%.

a) The voltage between COM and the input terminal (CN3 24V) on the main control board should be within $DC24V \pm 15\%$.

b) Check the specification of the main enter wire, and the capacity of switch should reach the requirements.

**Note**

If the system's enter voltage is over the allowable value, it will bring devastating consequences. So attention is required in inspection. Pay attention to the positive pole and negative pole of DC power. If there's phase missing in the system enter power part, please don't operate the lift.

4) Connection to the ground inspection

a) Check the resistance between grounding terminal PE and the terminal as follows, confirm whether it is infinite, if it is too small, check immediately

- R、S、T and PE
 - U、V、W and PE
 - Main board 24V and PE
 - Motor U、V、W and PE
 - Encoder 15V、A、B、PGM and PE
 - f) +、-Bus terminal and PE
 - Terminal of safe circuit, door lock, inspection circuit and PE
- b) Check the resistance between the grounding terminal of all the electric part and power input PE, it should be as small as possible. If it is too large, please check immediately.

7.1.2 Adjusting on the slow speed running lift

After the external inspection, get rid off the brake control wire, close the power, and observe no outputting of the brake control terminal when the lift is not in running state. Even if the brake control wire is connected, the brake won't open. Then cut off the power, and connect the brake control wire. Prepare for slow speed running.

1. Check after power-on

- 1) Check the voltage between COM and the input terminal (CN3 24V) on the main control board, It should be within $DC24V \pm 15\%$.
- 2) Check power of inside and outside calling, within $DC24V \pm 15\%$.
- 3) Check the voltage between 15V and PGM of CN6, value: $DC15V \pm 2\%$.

2. Check the parameters setting function of group F5

Terminal function parameter F5, decides whether the received signal is corresponding with signal sent to system, and whether the expected control aim is the same with the real control aim.

- 1) Please check according to the factory drawing whether the function of every terminal is correct, and whether the input type and output type are the same with the reality.
- 2) We can confirm whether the input state of corresponding terminal is correct by the lamp state and setting type of corresponding input and output terminals on the main control board

3. Motor tuning

Motor tuning must be in operation panel control model. Before tuning, please input parameter F1-00~F1-05. NICE 3000 elevator integrated controller matches standard motor parameters according to the nameplate parameter; distance-control mode depends on motor parameter deeply. To gain good control features, the motor parameter inputted must be correct. Details of tuning are described in chapter 6 and the application of synchronous motor in this chapter.

**Note**

Before the tuning of the synchronous motor, make sure the encoder has completed the installation and wiring. After the tuning of the synchronous motor, make sure the synchronous motor runs normally and then recover the wire rope.,

4. Door machine adjust

- 1) Check the connection of the door machine according to the instruction and the types of door machines. Measure the door machine's power. Move the car

into the door-area. Turn off the door machine's power. Place the door machine at adjustment state. Drive the land-door by door-machine. Observe door machine's running direction, running speed, torque, whether crash exists or not, and whether the door opens to the right position. Adjust door machine's parameters to make it run normally.

2) Set FB-00、FB-02~FB-05 according to the fact. Set FB-06、FB-08 according to width and speed of the door. Leave some allowance to avoid frequent protection of door machine. Set FB-09~FB-14 correctly to make the door running meet people' require (Generally the default can meet the requirements).

5. Test at low speed (inspection speed)

After complete the operations above, we can try to run the car at low speed (inspection speed). The speed is setting by F3-11.

1) Check input signal: view carefully whether the action sequence of the switch signals received in the travel proceeding is correct or not.

2) Check output signal: view carefully whether the definition of MCB ,NICE 3000 output terminal is correct and work of that is normal, and whether the signal and the contact controlled by MCB output terminal work well.

3) Check run direction: place the car at non-end floor and start low sped running, view whether the actual direction is the same with the aimed direction; if not, please exchange two phases of motor's three phases randomly.

4) Check encoder: if the speed is abnormal, swing when travel, the output current is too great or abnormal noise, please check connection of encoder, and exchange phase A, phase B

5) Check communication: view whether the communication indicate lamp COP, HOP are normal.

7.1.3 Adjusting on the high speed running lift

Before adjust at high speed, please confirm that up and down force reducer switch, end switch, limited switch act correctly, leveling flashboards are installed correctly; action sequence of leveling inductor is correctly. Connection of encoder is correct; F1-12 pulse number per rotation of the encoder is setting correctly.

1. Check before high speed

- 1) There's some interval between adjustment at low speed and that at high speed. Please repeat the check before testing at low speed.
- 2) Confirm the connection of car top board.
- 4) Connection of CAN communication and external calling is correct, and the voltage is $24V \pm 15\%$.
- 3) Confirm that force reducer switch, end switch, limited switch are installed correctly, and act reliably.
- 4) Confirm that each switch act reliably.
- 5) Confirm the connection of light-beam is correct.
- 6) Confirm that leveling inductor's connection is correct, and leveling plate is installed correctly.
- 7) Confirm that the connection of talking device is correct, and work normally.
- 8) Confirm connection of arrival chime
- 9) Confirm the connection of car illumination and fan.

2. Well self-tuning

- 1) Confirm that safety circuit and door circuit are connected well.

- 2) Make the system at inspection state.
- 3) Place the car at lowest floor, and guarantee down force reducer available
- 4) Set F6-00, F6-01 correctly, and guarantee that F4-01 is 1.
- 5) After getting into F-7 date menu by switching the mode through the UP and ENTER keyboard on MCB, the data displays "0". Press UP to change 0 to 1, and press ENTER, the system begins to floor self-study and runs to the top at inspection speed. Then it decelerates to stop with the deceleration of F3-08. It completes self-tuning. If not successful, system will indicate error E35. If error E45 occurs, the force reducer switch distance is not long enough, please refer to parameters of group F3.
- 6) Check the parameters of F3-12~F3-17, F4-04~F4-65 and observe whether the date of floor is written into or not.

**Note**

If the leveling flashboard is readjusted, please make self-study of well before running at high speed!

3、Weighing self-tuning

When system use the analog weighing:

- 1) Detect and confirm
 - A、Confirm that the weighing sensor voltage signal with 0~10V connects with car top board or main control board.
 - B、Setting F5-36 according to the weighing sensor type (Weighing input selection), and ensure F8-01=0.
- 2) Self-tuning operate way when no load
 - A、When it's in no load self-tuning, lift is in the main landing and ensure there's

no load in the car.

B、 Adjust the weighing sensor to appropriate position.

C、 Set F8-00=0, and press key ENTER.

3) Operation measures of load tuning

A、 When load tuning, lift is in the main landing and there are n% rated load in car.

B、 Set F8-00=n%, and press key ENTER.

System will automatically identify its weight value of full load and over load. After self-tuning, if system needs the pre-torque compensation function, set F8-01=1.

When the system uses the digital weighing:

Detect and confirm:

A、 Detect whether the weighing digital load of machine parts connect well.

B、 Detect that the digital load signal of full load and over load is exactly input into car top board (CTB) relevant signal input point.

Full load and over load tuning

A、 Put 100% rated load into the car. Adjust the switch position of full load to make full load switch act but over load switch not. The system memorizes it as full load.

B、 Put 110% rated load into the car. Adjust the switch position of over load. to make over load switch act. The system memorizes it as over load.

When complete upwards work, lift can be ready to run at high speed.

4、 Test at high speed

1) Car command testing

Let the lift in self-motion state. Key in signal level command by shortcut key F1 in small keyboard or function code F7-00 in special control panel. Observe whether the lift runs according to setting command or not.

2) External call command testing

Let the lift in self-motion state. Key in external call up and down command by function code F7-01, F7-02 in special control panel, or press every floor external call. Observe whether the lift runs according to setting command or not.

3) Door open and close function testing

When the lift stop at the landing, observe whether the door opens normally or not and whether door's keeping time meets the requirements or not. When lift responds to call and be to run, observe whether the door close normally or not.

5、 Fast speed running

After testing at high speed, stop lift and add required functions. Then start adjusting at high speed.

1) Set FE-32, FE-33 and F8-08 according to users' actual needs.

2) According to user and actual needs, adjust F6 group parameters; Set service floor, lock main landing F6-04, fire main landing F6-03, parking main landing F6-02, and group control, time-sharing control, parallel fastigium control.

3) Function test of fire return to main landing

If there is the fire return to main landing function availability and the fire main

landing is setting, dial the fire button in the fire landing. Then observe whether the lift can return to the fire landing normally and the door state meets the requirements.

4) Firemen run function

If there is fireman running function setting, after the lift's fire returns to the main landing, dial the fire button and the lift immediately gets into the fireman running state. The lift won't respond to the external call, and the door machine can only open the door when keep pressing on the open button. Once release the open button, the door close immediately.

5) Re-leveling function testing

If the re-leveling function is availability, observe whether the lift can re-level or not and the re-leveling speed meets the requirements or not. If error is over large, please adjust F3-10 appropriately.

6) Adjust for the feeling of comfortable

Adjusting the F3 group parameters to make lift run with comfortable feeling. If the lift is wobbling, amend relevant parameters according to curve chart 6-2. Details are described in section 6.4.

Notice: Lift comfortable feeling is affected by many factors. The miss-adjustment of machine part and the inappropriate section of parameters will bring on the bad comfortable feeling.

The effect on the comfortable feeling by the machine part generally can be caused in the following conditions:

- (1) Detect hoist machine's worm-wheel and worm-shaft.
- (2) Lift guide's verticality doesn't only affect horizontal tremor in running, but also affect the vertical shaking in running.

- (3) Lift's running quality is related to the car guide shoe. If want to achieve better PMT testing curve, you should do car static balance and car dynamic balance. Let car guide shoe bear the least resistance, and achieve lift best quality of running.
- (4) The counterweight guide shoe's miss-verticality and bearing resistance affect lift's comfortable feeling too.
- (5) Brake affect lift's starting and stopping dramatically.
- (6) It can affect lift comfortable feeling that the joint between the motor and hoist machine loose or fray.
- (7) The unbalanced pull of lift steel rope is the epicenter of the tremor.
- (8) The shock absorption tray under car top, car platform and machine platform all affect lift running quality.

Parameter selection affects lift comfortable feeling. Parameter unsuitable setting brings shake in vertical direction:

- 1、 F1-01~F1-11of motor parameters are main parameters of controller to control motor. If motor mode selection, parameter setting or self-tuning isn't right, it can bring on motor shaking or noise, and affects comfortable feeling.
- 2、 F1-12 set the pulse number of each rotation of the encoder. If the setting is different from the actual pulse number, it can cause that the controller can't recognize the current speed and position, thereby bring on the motor shaking or noise.
- 3、 F2-00~F2-07 are the using parameters when adjusting the controller PID is adjusting. It decides that the responding speed of the practically output voltage waveform of controller to the expected output value. It causes continuous

undulation that the proportion adjusting is too large or the integral adjusting is too little.

4、 F3-18:Output time of starting zero speed, F3-19: Time-lag of curve running, F3-20: Time-lag of end running. They relate to the condition that whether it's zero speed or not when the lift is starting or stopping and brake is open. If lift speed isn't 0, it can bring the pause feeling when starting and stopping.

5、 F3-03:Inflexion speedup time 1, F3-04: Inflexion speedup time 2.They is the speedup time of the S curve running to starting segment and ending segment. If the speedup time is too shot, it can bring shake at relevant moment and it can be appropriately increased.

6、 F3-06:Inflexion speed down time 1, F3-07: Inflexion speed down time 2. They are the speed down time of the S curve running to starting segment and ending segment. If the speed down time is too shot, it can bring shake at relevant moment and it can be appropriately increased.

7、 When F8-01=1 viz. Weighing preset torque compensation is used, F8-03 and F8-04 both affect lift starting comfort. If inappropriately adjust these parameters, it can bring shake when starting. The setting value relates with the weighing transducer's installation position, and the setting value is usually between 0.1~0.4.

8、 Leveling accuracy adjusting. When the mechanism adjustment completed, you can micro-adjust F4-00 to adjust the stopping accuracy. When lift stops, if it's over leveling, reduce F4-00 setting; if under leveling, increase F4-00.

7.2 Production Use

7.2.1 Main control board commendatory drawing and relevant parameters setting

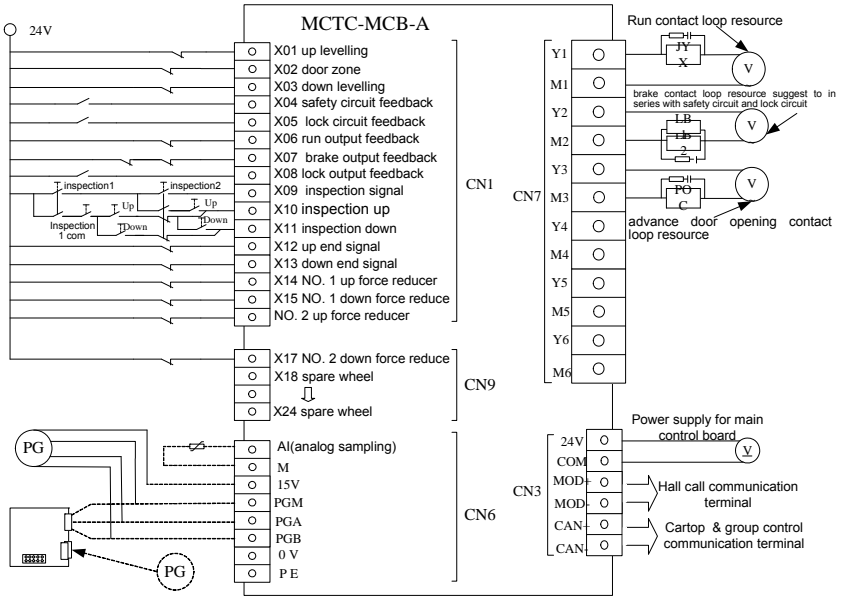

Chart 7-2 Main control board commendatory wiring

Adopt the connecting mode of upward drawing. The input and output terminal setting of the F5 group is default parameters.

7.2.2 Car top board commendatory drawing and relevant parameters setting

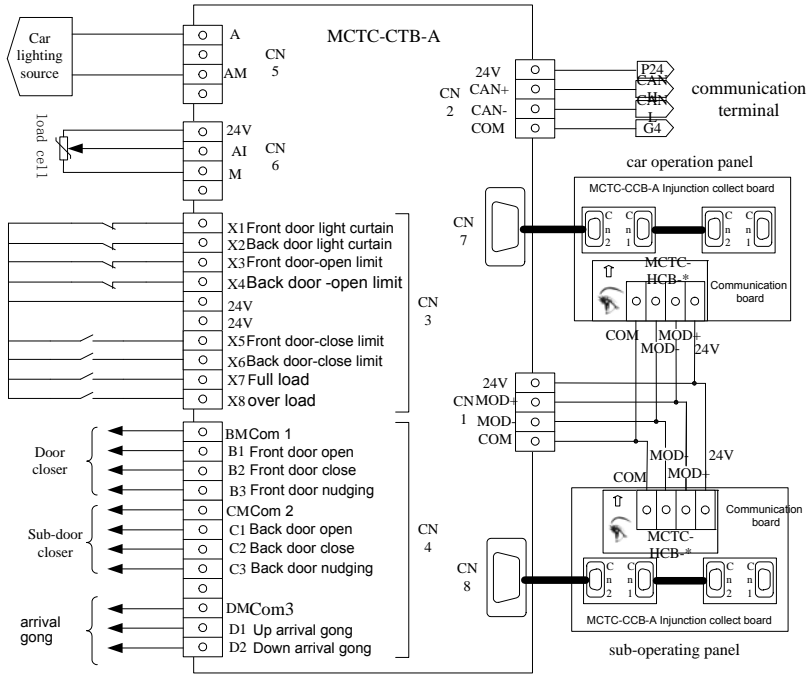

Chart 7-2 Car top board commendatory wiring

Adopt the connecting mode of upward drawing. The input and output terminal setting over load of the F5 group is N.O. type, and F5-25 setting parameter is 64.

Note

1. Add 3 to the default value if the light curtain1 and light curtain 2 are N.O., otherwise it won't change.
2. Add 12 to the former step if the open door limit 1 and open door limit 2 are N.O. , otherwise it won't change.

- If the wires of close door limit 1 and close door limit 2 have been connected and are N.O., add 48 to the last step, otherwise it won't change.
- If the full load is N.C., minus 64 to the last step, otherwise it won't change.
- If the over load switch is N.O., add 128 to the last step, otherwise it won't change.

7.3 NICE3000 Integrated controller without weighing application notes

Matching NICE3000 can adapter ERN1387 (SIN / COS type) rotary encoder by Matching MCTC-PG-C or MCTC-PG-E, For permanent magnet synchronous motor control. The elevator can achieve Pre-torque compensation function automatically without weighing

7.3.1 Function parameters of required special sets:

Function code	Default	modified value	Function code	Default	modified value
F1-00	1	0	F1-12	1024	2048
F3-19	0.2	>0.5	F8-01	0	2
F8-02	15.0%	15.0%	F8-03	0.50	0.50
F8-04	0.60	0.60			

7.3.2 Comfort adjustment

Section 6.9 , Functional parameters Second row of F8-02 ~ F8-04 primarily for regulating the the comfort of non-weighing start, Gradually adjust base on F8-02=15.0%, F8-03=0.50, F8-04=0.60 When adjusting

a) Gradually increase coefficient of zero current servo (F8-02), until Slide down

small and the motor not jitter after open the brake。

b) If the zero speed servo loop TI (F8-04) less than 1.00, If the motor; appear significant oscillation, Please increase the value of current coefficient of zero-servo (F8-02)。

c) Zero speed servo loop KP (F8-03) can remain unchanged, Don't tuned too lagre , Otherwise may cause motor oscillation easily。

7.4 Power failure emergency running program instruction

When the lift is in use, if the system's power suddenly broke, passengers may be trapped in the car cage. In light of the situation, NICE 3000 integrated controller designed a power failure emergency running (self-rescue running) program which is easy and convenient to fulfill.

NICE 3000 power failure emergency running program are separated into three modes according to the power source of the traction machine. They are auto-running car, 48V battery power running, and UPS power running. To facilitate the description, explanation as follows:

Auto-running car: It means that opening the brake, and the prevent-force limits the car's running by permanent-magnet synchronous motor jumps out stator coil. That is a rescue-way's which the car is running slowly to get to the level. After the Nice 3000 receives a power-failure-rescue signal, you should jump the U, V, W's wire of permanent-magnet synchronous motor, and open brake. The lift would auto-running. During the process you should monitor the lift's speed, till leveling. When the speed is slow, (The car is balance load or the load variation's number is small) you can close braking, and stop operation.

48V battery supply of power to run: The main circuit of NICE3000 has adopted 48V battery supply of power. The power of other part would adopt UPS supply which is greater than 220V. Do it, the motor can run normally by

store battery's power, and the work power's capacity will be small. After NICE3000 chooses the way which is power failure rescue, it would run with emergency speed (F8-09). The direction is the same to the running direction of lift light-load. Keep surveillance the speed of elevator in this period, and then output the passenger and stop running.

UPS supply of power: Both the main circuit and work-power of Nice 3000 have adopted UPS power to power failure emergency run. After NICE 3000 chooses the way of power failure rescue, it would run by emergency speed, the direction is the same to run direction of lift light-load run. When detecting signal, it will open the door and stop working.

From the description above, for the synchronous motor, it can choose auto-running car, 48V battery supply to run after the auto-running, or UPS supply to run after the auto-running. For the asynchronous motor, it can only choose 48V battery supply to run or UPS supply to run.

In order to distinguish the three modes mentioned above, their features are described in the following chart.

Mode	Source of motor's power	Work-power of NICE1000	Work-power of the lift's safety circuit	Range	Other
Auto-running car	Permanent-magnet synchronous motor jumps stator coil	Using the UPS which is greater than 220V (or inverter)	Using the UPS which is greater than 220V (or inverter)	Permanent-magnet synchronous motor	Need 封星 contact or to attach U,V,W
UPS supply of power	220V UPS applies of power	220V UPS applies of power	220V UPS applies of power	Permanent-magnet synchronous or	

Mode	Source of motor's power	Work-power of NICE1000	Work-power of the lift's safety circuit	Range	Other
				asynchronous motor	
48V battery supply of power	48V store battery	Using the UPS which is greater than 220V(or inverter)	Using the UPS which is greater than 220V(or inverter)	Permanent-magnet synchronous or asynchronous motor	

We mainly introduce typical application of auto-running by the following chart. If use other way (include rescue automatically switch). You can contact with us.

7.4.1 NICE3000 power failure emergency run system sketch

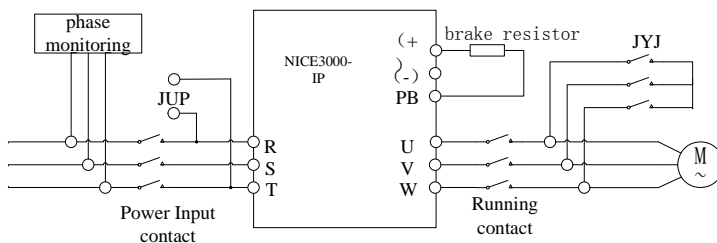

1) Main circuit sketch

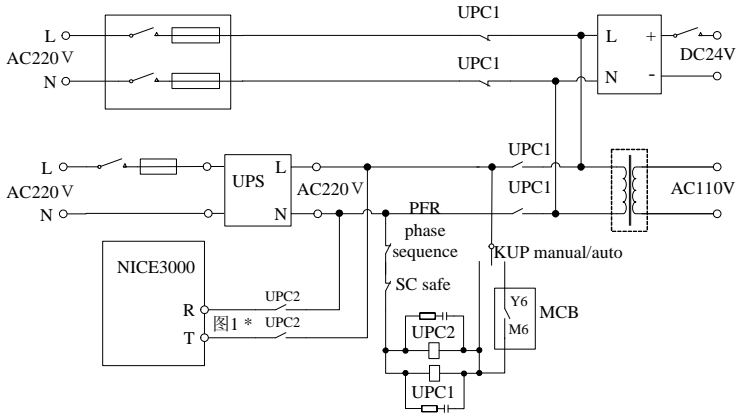

2) UPS power circuit diagram

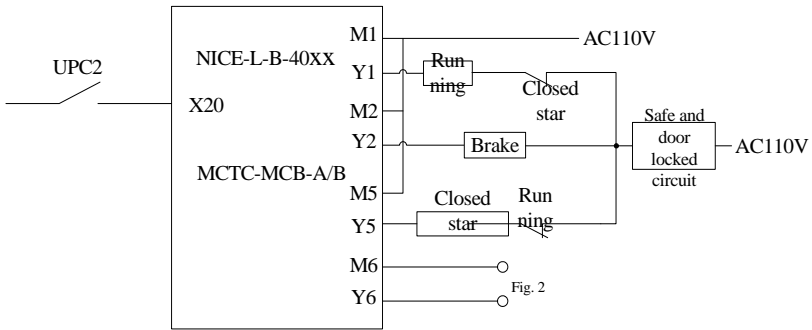

3) Main control board wiring chart

Chart 7-6 Power failure emergency run system sketch

Explanation: 1)-3), JYX is the output wiring contactor; JYJ is the star-closure contactor of synchronous motor; JUP is power failure rescue run manual switch; JAQ is safety signal. In this case, UPS will supply power to door operation, safety circuit, brake and so on. In the application, UPS has no large load, and its capacity can just select 1KVA.

7.4.2 Power failure rescue running instruction

1 Time sequence diagram

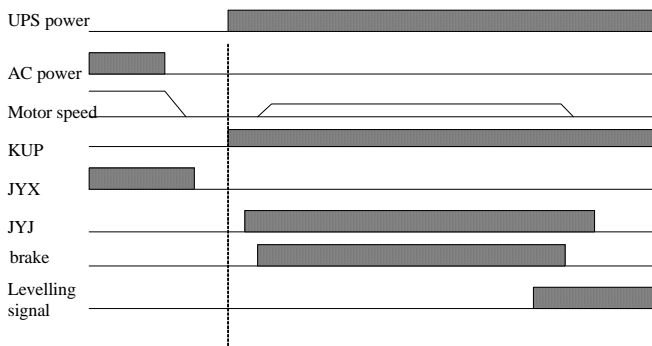

Chart 7-7 Auto-running time sequence

2 Function code setting

According to wiring diagram, the NICE3000 auto-running power failure emergency running needs set the following parameter:

Function code	Name	Setting Range	Min. Unit	Default	Setting when emergency running
F5-20	X20 function selection	0~63	1	0	27
F5-30	Y5 function selection	0~16	1	5	12
FE-32	Lift factory function selection	0~65535	1	3075	11267 BIT13 setting is "1"

3 Attention items

- 1) During the auto-running is run, the NICE3000 can't control the motor drive, the power of life auto-running is come from self-supply power of synchronous motor;
- 2) During the auto-running is run, if the lift's speed is more than 1/2 rated speed, the NICE3000 will adopt alarm protect (E33), don't be controlled by auto-running, and at the same time the jump contactor of synchronous motor maybe get abnormality;
- 3) This way is only applied to synchronous motor, and never be applied to asynchronous motor, otherwise, it will be very dangerous;
- 4) This way need some gap between load in the car and load of lift balance; otherwise, the lift run-speed will be slow.

4 Manual switch modes

From the above system, normality, the KUP should have disconnected. When the UPS is charging, the system's power comes from main power supply. When the main power is cut, user can control system emergency by KUP, and the KUP is close, UPS power is supplied to system power. When NICE3000 receives the UPS of X20 input signal, and make sure the mode is power failure emergency run, close K5, then open brake, the lift will auto-running; at the same time monitor lift speed, till leveling.

7.5 Parallel program instruction

NICE 3000 integrated controller has the parallel control function. Two NICE 3000 control systems can change and deal with the elevator information through CAN communication, thus it can realize the function of two elevators harmoniously correspond to the external call which increase the lift efficiency.

NICE 3000 system's parallel disposal logic adopts multi-principles integrated disposal, covering call responding time, lift use efficiency, passengers waiting

time in car and so on, which enable to the advantages of the integrated controller. When the effective external call has been registered, NICE 3000 system will actually record the time two elevators responding to the call (Considering distance, list stop door switch, etc.), and then responds to each call in the most appropriate way thus reduce passenger's waiting for the lift to the maximum extent. The parallel program of NICE 3000 also includes parallel off, fastigium service, service floor management, and collective selective management function and so on. Details are described in chapter 6, corresponding instruction of function codes.

In parallel, the two lifts are main lift and subordinate lift. When the condition of responding to the external call is totally the same, NICE 3000 system allocates the main lift or the subordinate lift to respond to the call through random function. This can avoid the unbalance use of two elevators.

7.5.1 Parallel setting

The following two function coders need setting to fulfill the parallel function of NICE 3000.

Function code	Name	Setting Range	Setting when parallel
F6-07	Group control quantity	1~8	2
F6-08	Lift number	1、 2	Main lift: 1 Subordinate lift: 2

If the floor structure of two parallel lifts is different, other setting is needed. Details are explained in the parallel case instruction of section 7.5.3.

7.5.2 Parallel wiring sketch

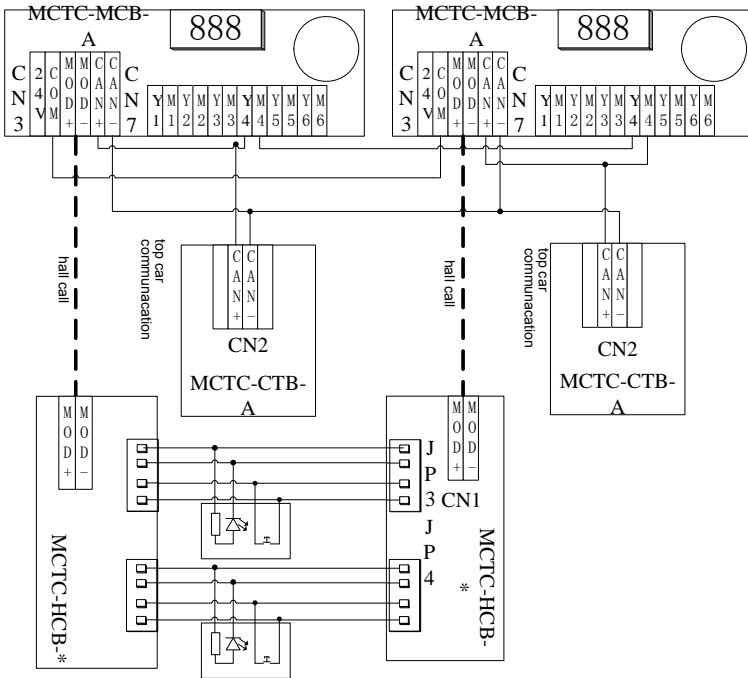

Chart 7-8 Parallel wiring

The chart shows the wiring mode of external call button and the wiring mode of parallel CAN communication. When in using, the following items should be paid attention to:

1. Car top board dial setting

In parallel, the car top board's dial switch of the main lift with the number 1 is the same with it's used in single lift, which means the first bit of Sw1 is on OFF position; the car top board's dial switch of the subordinate lift with the number 2, Sw1's first bit should be setting on ON position; otherwise it will cause the abnormal data communication of the lift's car top.

2. CAN communication net's terminal resistance disposal

In parallel, the communication terminal resistances dial of two lifts' car top control board need to be switched to the "ON" position. The J5 on the main control board chooses not to connect the terminal resistance (to connect the two pins above, when the small keyboard is on the top, the method is not suitable for the VER A, VER B, VER C edition). In this way, there's terminal resistance only in the terminal car top board in CAN communication net.

3. Main control board relay output setting

In the above chart, the two lifts' CAN+ of the CAN communication wiring is trans-connected through the Y4-M4 on the main control board, which confirms the two lifts won't affect each other when the power is broken or other abnormal condition occurs. Therefore the following function codes need setting:

Function code	Name	Setting Range	Setting when parallel
F5-29	Y4 function selection	0~14	14

7.5.3 Parallel lift's case instruction

After the two lifts are in parallel, when the stopping position of the two lifts is different, the lift's external call dial is different from that of single lift running. When the lift adjustment is completed and gets into the parallel function adjustment step, generally connect the parallel wiring according to the former description and set the car top dial code and main control board output setting. But in some special condition, special disposal is needed. Several typical examples are listed in the following, and it can flexibly apply according to the examples.

For example: Suppose that there are two lifts in parallel, the No.1 lift stops at Floor B1, Floor 1, Floor 2, and Floor 3; the No. 2 lift stops at Floor 1, Floor 3, and Floor 4; Now the two lifts are both setting parallel according to section 7.5.1 and 7.5.2. The required special setting is listed as follows:

1. Floor dial code setting, display setting



Note

When two lifts are in parallel, if the floor structure is different, the counting of the floor is according to the lowest floor's minimum value to the highest floor's maximum value, and corresponding dial code is according to the lowest floor's minimum value, cumulated by the physical floor. The overlapped service floor zone still needs install leveling plate in the well even if the lift doesn't stop at this floor. Set the service floor to make the lift doesn't stop at this floor. In the example, Floor 1 and Floor 3 are in the overlapped service floor zone, but No.2 lift's Floor 2 doesn't have the floor door, which means it doesn't serve the Floor 2, but this floor still needs install leveling plate.

The corresponding setting of No.1 lift:

state floor	Bit of DIP switch					Physical floor	Display setting
	1	2	3	4	8		
B1	ON	OFF	OFF	OFF	ON	1	FE-01=1101
1	OFF	ON	OFF	OFF	OFF	2	FE-02=1901
2	ON	ON	OFF	OFF	OFF	3	FE-03=1902
3	OFF	OFF	ON	OFF	OFF	4	FE-04=1903

The corresponding setting of No.2 lift:

state floor	Bit of DIP switch	1	2	3	4	8	Physical floor	Display setting
	1	OFF	ON	OFF	OFF	ON	2	FE-02=1901
2	Not service, but must installation leveling plate							FE-03 =1902
3	OFF	OFF	ON	OFF	OFF	4	FE-04=1903	
4	ON	OFF	ON	OFF	OFF	5	FE-05=1904	

2. The setting of the highest, lowest and service floor



Note

When two lifts are in parallel, if the floor structure is different, the F6-01 setting of the lowest floor should be the same with the external call dial code of the corresponding lift's lowest floor. The setting of the highest floor should be the same with the corresponding physical floor's floor number of the highest floor's external call dial code.

Following the principles mentioned above, the lift's corresponding setting in the example should be:

No.1 lift F6-00=4 6-01=1, No.2 lift F6-00=5 F6-01=2

3. The setting of service floor

As the instruction in 1, the Floor 2 of the No.2 lift in the example has the leveling plate but no floor door, so it is no service floor, and needs to set service floor F6-05=65533.

7.6 Instruction of group control program

Details refer to the instruction of group control

7.7 Instruction of overload and full load

In order to facilitate the use of different users, NICE 3000 integrated controller supplies three over load and full load signals inputting mode to fulfill these functions. When in use, correctly set the corresponding parameters to avoid miss-operation. Briefly explain its use in the following:

7.7.1 Car top switch's terminal inputting mode:

When F5-36 is setting as 1, select car top switch inputting mode to fulfill over load.

The car top board of NICE 3000 (MCTC-CTB-A) has 8 switch inputting terminals (CN3). Among those, the corresponding function of X7 terminal is full load signal, and that of X8 is over load signal. The properties of these inputting terminals are defined by function code (F5-25). If the F5-25's parameter BIT6=1, the car top board signal X7 is N.O.; If the F5-25's parameter BIT6=0, the car top board signal X7 is N.C. The properties of over load signal X8 are the same. Relationship is as follows, and the "X" in the following chart means any number:

Over load switch's property	F5-25 correct parameters setting	Car top board X8 terminal's inputting voltage (V)	NICE 3000 state
N.O.	1xxx,xxxx	24V	Over load state
	1xxx,xxxx	0V	Normal state
N.C.	0xxx,xxxx	24V	Normal state
	0xxx,xxxx	0V	Over load state

Suitable for car top board switch signal, to fulfill overload and full load needs set F5-36=1.

7.7.2 Main control board switch's terminal inputting mode:

There are 24 switch inputting terminals (CN1, CN9) of NICE 3000 integrated controller's main control board. Each terminal has more than 60 function selections. Details refer to the instruction of F5 in chapter 6. Selection 14, 15, 46, 47 are separately corresponding to the full load and over load functions, and they have explained these inputting signals' properties. Users can use them according to the function.

Take the over load for example, if the user installs the over load switch at the beginning of the rope of the machine room, use the N.C. point; If the main control board prepares to use terminal X23 as over load inputting, it should set F5-23 as 46, and input the N.C. signal of the over load switch to X23.

In this way, set F5-36 as 0.

7.7.3 Analog signal inputting mode:

There are two inputting passages of the analog signal in NICE 3000 system: CN6 of the car top board (MCTC-CTB-A), CN9 of the main control board (MCTC-MCB-A).

If the pre-torque of NICE 3000 uses analog signal inputting, users can take the no load and full load self-tuning through the weighing self-tuning function (F8-00, details refer to the function instruction in chapter 6), among these, F8-06 is corresponding to no load sampling point's data, and F8-07 is corresponding to full load sampling point's data. According to these information and sampling of current analog weighing signal, NICE 3000 can judge the car cage's load condition. If it's over 110% of full load, it indicates over load; if over 100%, it indicates full load. One point should be paid attention is that the maximum range of the car cage's weighing analog signal's sampling is 0~255. Therefore, if the sampling value of 110% car cage's load is over this range, over load will never occur!

When in this way, experienced staff is required to operate in order to avoid over

load without alarming!

If analog signal connected to the car top board, set F5-36=2; if it's connected to the main control board, set F5-36=3.

7.8 Instruction of plural external call in the same floor

According to the users' needs, some floors may need to be equipped with plural external call. Generally they are freight lifts with open-through doors, and there's only one floor with plural external call in most of the lifts. Considering this condition, NICE 3000 supply corresponding solutions.

7.8.1 Below the ten floors of the lift, one of them is plural external call

In this condition, select door 2 external call of the plural external call, set the corresponding dial code as 31, and set the external call's corresponding floor through FE-31. For example, if there are plural external call in Floor1, the door2's external call switch is 31 and set FE-31-0001.

7.8.2 Multi-floors with plural external call

In this condition, it needs extra wiring in the well. The plural external call wiring is as follows:

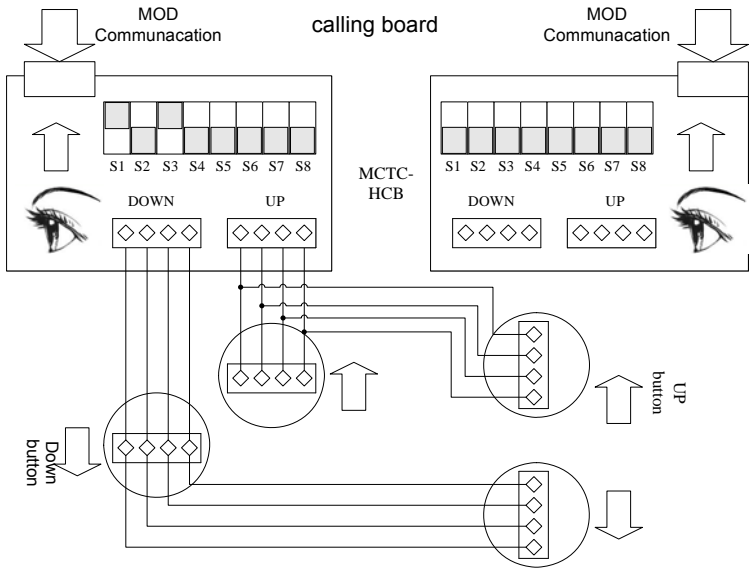

Chart 7-9 Plural external call wiring in the same floor

Wiring as the chart above can fulfill multi-floors' plural external call in one lift.

Note: When in the practical wiring, pay attention to the button's power wiring and switch signal's wiring, they should be corresponding to the display board's 4 PIN plugs 24V, GND, KEY-IN, KEY-LED, in order to avoid the damage to the display board.



Fault diagnosis and countermeasures

Chapter 8 Fault diagnosis and countermeasures

8.1 Fault mode explanation

The lift integrated controller has almost 60 pieces of alarm information or protection functions. It monitors all kinds of input signal, running condition, exterior feedback information. If some abnormal error happens, relevant fault protection functions will act and the system controller will display the fault code.

The lift integrated controller is a complicated electric control system. Error information produced by NICE 3000 can be divided into 5 sorts according to their influence to the system. Different fault has different disposal mode. And the respective relationship is listed in the next table:

Fault sort	Relevant disposal	Remark
Level 1 fault	Display fault code; Error relay output action;	Any kind of working condition will not be influenced.
Level 2 fault	Display fault code; Error relay output action; Sever lift group control (parallel) system;	Can carry through natural running.
Level 3 fault	Display fault code; Error relay output action; Stop at the nearest landing when in distance control, then stop running; Stop running at once in other work condition.	After stop, the system will close off output at once, and close brake.
Level 4 fault	Display fault code; Error relay output action;	The elevator can run in low speed in condition of fault

Fault sort	Relevant disposal	Remark
	When in distance control, the system will close off output at once and close brake; after stop, low speed running (such as return leveling, inspection) is allowed.	code.
Level 5 fault	Express fault code; Error relay output action; The system blank off output at once, and close brake; Forbid running.	Forbid running.

8.2 Fault information and countermeasures

If fault alarm information appears, the system will dispose by their fault code. At this time, user can construe fault on basis of suggestive information in this chapter, to ensure fault cause, and find out solution

Operate panel display	Digital tube display	Fault description	Fault cause	Disposal way	Sort
Err01	E01	Inverse unit protection	1.Main loop output is grounding or short wiring; 2.The connection of traction machine is too long; 3.Work condition is too hot; 4.The	1.Obviate exterior problems such as connection; 2.Add reactor or output filter; 3.Inspect the wind channel and fan; 4.Please contact with agent or factory;	5

Operate panel display	Digital tube display	Fault description	Fault cause	Disposal way	Sort
			connections inside the controller become loose;		
Err02	E02	Accelerated over current	1.Main loop output is grounding or short wiring; 2.If the motor has done parameter tuning of not; 3.Load is too heavy;	1.Obviate exterior problems such as connection; 2.Motor parameter tuning; 3.Lighten sudden adding load;	5
Err03	E03	Decelerated over current	1.Main loop output is grounding or short wiring; 2.If the motor has done parameter tuning of not; 3.Load is too heavy; 4.Decelerate curve is too steep;	1.Obviate exterior problems such as connection; 2.Motor parameter tuning; 3.Lighten sudden adding load; 4.Adjust the curve parameter;	5
Err04	E04	Constant speed over	1.Main loop output is	1.Obviate exterior problems such as	5

Operate panel display	Digital tube display	Fault description	Fault cause	Disposal way	Sort
		current	grounding or short wiring; 2.If the motor has done parameter tuning of not; 3.Load is too heavy; 4.Pulse wheel encoder interference is too strong;	connection; 2.Motor parameter tuning; 3.Lighten sudden adding load; 4.Select proper encoder, and adopt shielded cable;	
Err05	E05	Accelerated over voltage	1.Input voltage is too high; 2.Lift inverse pull is serious; 3.Brake resistance is too much, or brake unit is abnormal; 4.Accelerate curve is too steep;	1.Adjust input voltage; 2.Adjust the elevator startup time sequence; 3.Select proper brake resistance; 4.Adjust curve parameter;	5
Err06	E06	Decelerated over voltage	1.Input voltage is too high; 2.Brake resistance is too much, or brake	1.Adjust input voltage; 2.Select proper brake resistance; 3.Adjust curve parameter;	5

Operate panel display	Digital tube display	Fault description	Fault cause	Disposal way	Sort
			unit is abnormal; 3.Accelerate curve is too steep;		
Err07	E07	Constant speed over voltage	1.Input voltage is too high; 2.Brake resistance is too much, or brake unit is abnormal;	1.Adjust input voltage; 2.Select proper brake resistance;	5
Err08	E08	Controller power fault	1.Input voltage is too high; 2.Drive control panel is abnormal;	1.Adjust input voltage; 2.Please contact with agent or factory;	3
Err09	E09	Under voltage fault	1.Transient power cut exists; 2.Input voltage is too low; 3.Drive control panel is abnormal;	1.Obviate exterior problem of power; 2.Please contact with agent or factory;	5
Err 10	E10	System overload	1.Brake loop is abnormal; 2.Load is too heavy;	1.Inspect brake loop and power supply; 1.Lighten load;	4
Err 11	E11	Motor	1.FC-02 setting	1.Adjust parameter;	3

Operate panel display	Digital tube display	Fault description	Fault cause	Disposal way	Sort
		overload	is unsuitable; 2.Brake loop is abnormal; 3.Load is too heavy;	2.Inspect brake loop and power supply;	
Err 12	E12	Input side phase failure	1.Input power asymmetry; 2.Diver control panel is abnormal;	1.Adjust input power; 2.Please contact with agent or factory;	4
Err 13	E13	Output side phase failure	1.The connections of main loop output become loose; 2.Motor is broken;	1.Inspect connection; 2.Obviate motor fault;	4
Err 14	E14	Module overheated	1.The temperature of working environment is too high; 2.The fan is broken; 3.The wind channel is blocked;	1.Reduce the environmental temperature; 2.Clear the wind channel; 3.Change the fan;	5
Err 17	E17	Contact	1.Bus voltage is	Please contact with	5

Operate panel display	Digital tube display	Fault description	Fault cause	Disposal way	Sort
		fault	abnormal; 2.Drive control panel is abnormal;	agent or factory;	
Err 18	E18	Current detection fault	Diver control panel is abnormal;	Please contact with agent or factory;	5
Err 19	E19	Motor tuning fault	1.Motor parameter setting is wrong; 2.Parameter tuning is overtime; 3.Synchronous rotate encoder is abnormal;	1.Input the right motor parameter; 2.Detect motor lead wire; 3.Detect the rotate encoder wiring, and make sure the pulse number per round is well set.	5
Err 20	E20	Rotary encoder fault	1.Rotary encoder model is suited or not; 2.Encoder connection error;	1.Asynchronous motor can select push-pull output or open-collector encoders; synchronous motor can select UVW or SIN/COS. 2.Obviate connection problem;	5
Err 21	E21	Synchronous	Error occurs to	Please detect the	5

Operate panel display	Digital tube display	Fault description	Fault cause	Disposal way	Sort
		encoder wiring fault	the wiring of synchronous encoder;	wiring;	
Err 22	E22	Leveling and door area signal conglutination fault	Leveling/door area signal is conglutination or cut off;	Please detect the leveling/door area inductor and main control panel input point.	1
Err 23	E23	Short circuit fault to ground	Output short circuit to ground;	Please contact with agent or factory;	5
Err 25	E25	Stored data abnormality	The stored data of main control panel is abnormal;	Please contact with agent or factory;	5
Err 29	E29	Synchronous motor self-lock contactor feedback abnormality	The feedback of synchronous motor self-lock contactor is abnormal;	Detect relevant wiring;	5
Err 30	E30	Elevator position abnormality	1.Encoder feedback position deviation when lift is automatic running;	1.Detect leveling inductor and flashboard; 2.Detect leveling signal wire connecting;	4

Operate panel display	Digital tube display	Fault description	Fault cause	Disposal way	Sort
			2.Levelling signal is cut or conglutinate when lift is automatic running; 3.Steel wire skid or motor locked-rotor;	3.Ensure encoder is used right;	
Err 31	E31	DPRAM abnormity	Reading and writing of DPRAM is abnormal	Please contact with the agency or the factory to change the control board	3
Err32	E32	CPU abnormity	CPU works abnormally	Please contact with the agency or the factory to change the control board	5
Err 33	E33	Lift speed abnormity	1.Actual speed is 15% over the highest running speed; 2.Low speed running is 20% over the setting speed; 3. Inspection switch acts when	1.Ensure encoder is used right; 2.Detect motor nameplate parameter setting; 3.Retune motor; 4.Detect the inspection switch and signal wire;	4

Operate panel display	Digital tube display	Fault description	Fault cause	Disposal way	Sort
			lift automatic running;		
Err 34	E34	Logic fault	The control panel redundancy judge, logic fault.	Please contact with agent or factory to replace control panel.	5
Err 35	E35	Shaft self-tuning data abnormality	<p>1.The startup place is not the lowest floor;</p> <p>2.Continuous run time is more than 45 seconds without signal input;</p> <p>3.The interval of floors is too short;</p> <p>4.The highest metrical floor is different with the setting value;</p> <p>5.The floor pulse record is abnormal;</p> <p>6.When in self-tuning, the system is not in examine state;</p>	<p>1.Ensure up/down force reducer switch and signal;</p> <p>2.Detect leveling inductor and flashboard setting;</p> <p>3.Detect leveling signal wire connecting;</p> <p>4.Make sure that the system is in examining state.</p> <p>5.Carry through shaft self-tuning again when lift reaches the lowest floor;</p>	4

Operate panel display	Digital tube display	Fault description	Fault cause	Disposal way	Sort
Err 36	E36	Contact feedback abnormality	1. Running contactor is not pulled in when the brake is open; 2. When lift continuously runs over 1 second, the contact feedback signal is lost; 3. The contactor feedback signal conglutinates; 4. No feedback signal after the contact closed;	1. Detect contactor and feedback contact; 2. Detect that the controller output wire U,V,W is natural or not; 3. Detect that the circuit power of contact controlling is natural or not;	5
Err 37	E37	Brake feedback abnormality	The brake output is not consistent with the feedback signal.	1. Detect that the brake coil and feedback contact; 2. Notarize the signal character of the feedback contact (N.O. or N.C.); 3. Detect that the circuit power of brake coil controlling is	5

Operate panel display	Digital tube display	Fault description	Fault cause	Disposal way	Sort
				natural or not;	
Err 38	E38	Controller encode signal abnormality	<p>1.No input encode pulse when lift is automatic running;</p> <p>2.The direction of input encode signal is wrong when lift is automatic running;</p> <p>3.Set to open-loop (F0-00) when in distance control;</p>	<p>1.Ensure encoder using right;</p> <p>2.Replce encoder's A,B phase;</p> <p>3.Detect the setting of F0-00, and change to close-loop control;</p>	5
Err 39	E39	Motor overheated	Motor overheated and relay output valid	<p>1: Lift's speed is too low or the floor is too high</p> <p>2: Improve the motor's radiator</p>	
Err 40	E40	Lift run overtime	The setting time of lift running is up.	<p>1.Lift speed is too low or the floor is too high;</p> <p>2.The lift is used for a long time and needs maintenance;</p>	4
Err 41	E41	Safety circuit	The signal of	1.Detect safety circuit,	5

Operate panel display	Digital tube display	Fault description	Fault cause	Disposal way	Sort
		off	safety circuit is cut.	and look over its state; 2.Detect that exterior power supply is natural or not;	
Err 42	E42	Door lock cut in running	The door lock feedback is cut when lift is running.	Detect that the door lock contact is natural or not.	5
Err 43	E43	Up limit signal off in running	The signal of up limit is cut when lift is up running.	Detect that the up limit switch contact is natural or not.	4
Err 44	E44	Down limit signal off in running	The signal of down limit is cut when lift is down running.	Detect that the down limit switch contact is natural or not.	4
Err 45	E45	Up/Down slowdown switch off	Up and down slowdown switch is cut at one time when the elevator stops.	1.Detect 1st up/down slowdown switch; 2. Ensure 1st up/down slowdown signal characteristic (N.O. or N.C.);	4
Err 46	E46	Re-leveling abnormality	1.The speed of re-leveling is over 0.1m/s; 2.Re-levelling position is not in the leveling area;	1.Detect the connection of lock relay. 2.Detect that the door lock feedback function is selected or not, and	1

Operate panel display	Digital tube display	Fault description	Fault cause	Disposal way	Sort
			3.The door lock feedback is abnormal when in running.	signal is natural or not; 2.Ensure the rotary encoder is used right;	
Err 47	E47	Door-close contactor adhesion	Contactor is conglutinated when having advance open door and re-leveling.	Detect door-close contactor	5
Err 48	E48	Door open fault	The door continuous non-arrival open times are over the setting value of FB-09.	1.Detect that the door machine is working natural or not; 2.Detect the car top control panel is right or not;	5
Err 49	E49	Door close fault	The door continuous non-arrival close times are over the setting value of FB-09.	1.Detect that the door machine is working natural or not; 2.Detect that the car top control panel is right or not;	5
Err 50	E50	Group control communication error	Group control communication continuously error more than 10s	1.Check the connection of the communication wiring 2. check the address definition of lift	2

Operate panel display	Digital tube display	Fault description	Fault cause	Disposal way	Sort
				integrated controller	
Err 51	E51	CAN communication error	1: CAN communication continuously no correct feedback data 2: CAN communication receipt continuously error	1. Check the connection of the communication wiring 2. Check the car top board power 3. Check the 24V power source of lift integrated controller 4.	3
Err 52	E52	External call communication error	External communication with no correct feedback data	1. Check the connection of the communication wiring 2. Check the 24V power source of lift integrated controller 3. Check whether the setting of the external call control board is repeated	1
Err 53	E53	Lock jump fault	When in automatic running state, the	Detect the lock signal circuit.	4

Operate panel display	Digital tube display	Fault description	Fault cause	Disposal way	Sort
			stop has no door lock cut process;		

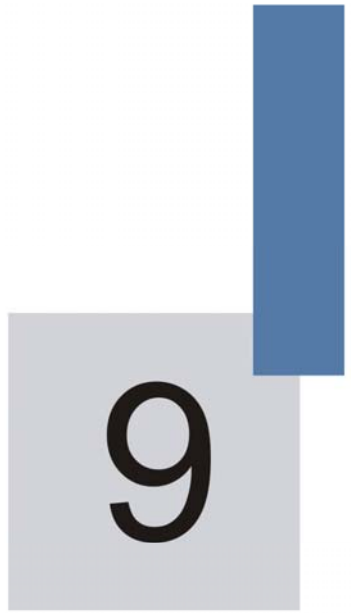

Instruction of accessory products

Chapter 9 Instruction of accessory products

9.1 Using Introduction of CTB

Car top board MCTC-CTB-A is the main control board of NICE 3000's car cage. It is made up of eight digital signal input terminals, one analog voltage signal input terminal, eight relay N.O. output terminal, one N.C. relay output terminal, two digital signal input and output terminals which can communicate with the command board CCB, CAN communication terminal with MCB, communication terminal with car display board Modbus, and RS232 communication mode which supports the communication with the upper computer. It's of great function and is the important transferring station of signal collection and signal outputting control in NICE 3000 integrated controller.

9.1.1 Appearance and size

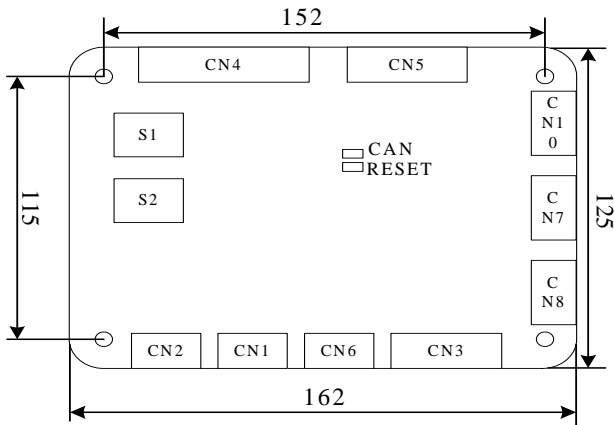

Chart 9-1 Installing size of CTB

9.1.2 Introduction of installation and using

1. Installing method

- 1) Install it after the complete power failure of the lift;
- 2) Aim at four installing pores of car, and then use screwdriver to hold;
- 3) Link terminals and screw down.

2. Definition of terminals is shown in Chart 9-2:

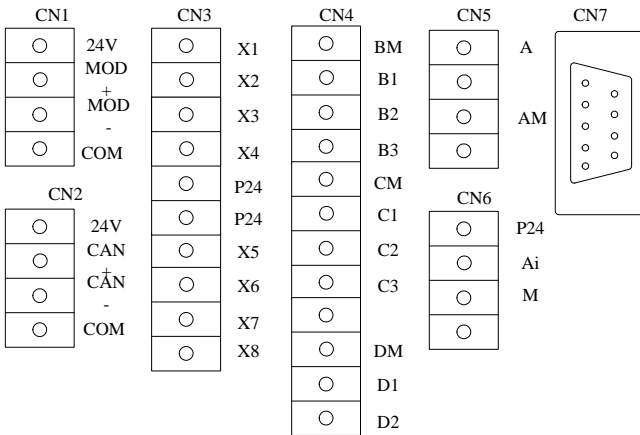

Chart 9-2 Definition of CTB terminals

3. Explanation of controlling terminals' function

Type	Terminal designation	Terminal name	Functional explanation
Power	24V (CN1、CN2 terminals)	Connect to +24V external power source	Provide+24Vpower for whole board as Operational Power Supply
	COM	Connect externally to	

Type	Terminal designation	Terminal name	Functional explanation
	(CN1、CN2 terminals)	common port	Common port of digital input and analog input
	P24 (other terminals)	+24V power source	
Function digital input	X1	Font door beam screen	1、 Photocoupler isolation, unipolarity input 2、 Input impedance: 3.3KΩ 3、 MCTC-CTB signal is valid when inputting 24V power
	X2	Back door beam screen	
	X3	Font door open limit	
	X4	Back door open limit	
	X5	Front door-close limit	
	X6	Back door-close limit	
	X7	Full load signal (100%)	
	X8	Over load signal (110%)	
Analog input	Ai-M	Weighing signal input	DC: 0~10V
Relay output	A-AM	Car fan / illuminate controller	AC: 250V, 3 ^a Or DC: 30V, 1A
	B1-BM	Front Door opening signal	DC: 30V, 1A
	B2-BM	Front Door closing signal	
	B3-BM	Door lock (Closed indicates the door lock is smooth)	
	C1-CM	Back Door opening signal	
	C2-CM	Back Door closing signal	
	C3-CM	Door lock (Closed indicates the door lock is smooth)	
	D1-DM	Up arrival signal	
	D2-DM	Down arrival signal	

Type	Terminal designation	Terminal name	Functional explanation
communication	CAN+/CAN-	CAN communication	Communicate with controller of NICE3000
	MOD+/MOD-	Modbus communication	Communicate with Modbus Caution: car MOD communication has the same connection with hall call. Consult 9.3
	CN10	RS232 communication	Factory use.
	CN7 CN8	Command board communication	Make the digital signal inputting and outputting communication with command board. Consult 9.2 the instruction of command board.

4、Functional introduction of each dial card's switch of CTB:

Name	Dial card	Functional Description
SW1	1	Use for Parallel connection, the car top board of No.2 parallel lift switches to "ON".
	2	Reserved
	3	Reserved (Factory using)
	4	Matching resistance of Modbus whole line terminal
	5	Matching resistance of CAN whole line terminal

Cautions:

- 1) In order to protect communication signals from external disturbance, we advise to use STP for communication connection ,and do the best not to disturb parallel;
- 2) It is better to use Shielded cable for signal wiring of communication;
- 3) Connect strictly according to terminal signal, and screw down.

9.2 Using introduction of CCB

Command board CCB is matched with car top board CTB in NICE 3000 integrated controller. Each command board comprises 24 input interfaces and 22 output interfaces, including 16 floor buttons and 8 functional signals. Its function is to collect button instruction and output showing light source. In order to meet 32 floors' need, we adopt concatenation. And then through the parallel, it can meet the needs of two command inputting light output operation panels in the car cage.

9.2.1 Appearance and size

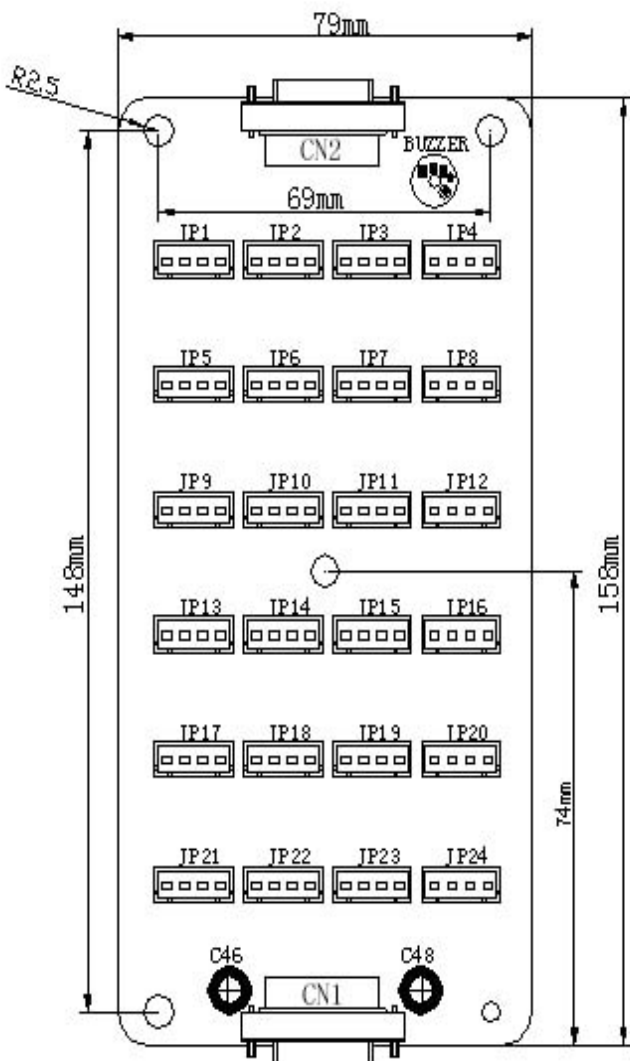

Chart 9-3 Installation size of CCB

9.2.2 Introduction of installation and using

1. Installation mode

1) Install in the condition of power off;

2) Aim at four installing pores of car, and then use screwdriver to hold;

3) After checking the order of button connection and button plug, plug button switch into instruction plate's slot;

4) Connect to the car top board through terminals, and make sure that connection end is instruction plate CN2's interface. If connection end is CN1, CTB or instruction plate can be destroyed.

2. Definition of terminals' interface

1) A connection interface that adopts 9PIN parts of an apparatus is in the up and down end of the instruction plate, can communicate with car top board, and make concatenation with two command boards. The concatenation relationship between car top board and command board is shown in Chart9-4:

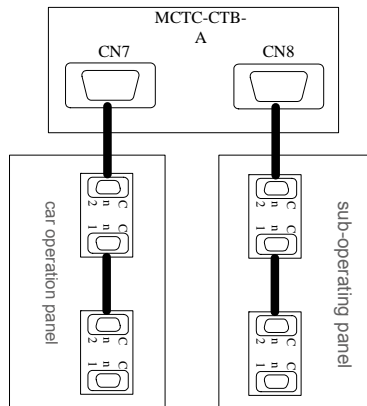

Chart 9-4 Concatenation sketch between CTB and CCB

2) Definition of 4 PIN interface

Command board's 4 PIN interface's definition of VER-A, VER-B, VER-0 edition is shown in the following chart 9-5:

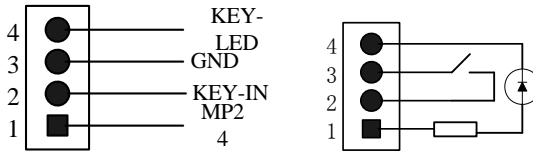

Chart 9-5 Command board's 4 PIN interface's definition and external connection of VER-A, VER-B, VER-0 edition

When use these three command boards, users must pay attention to the wiring and the use of buttons between MP24 and GND. Do not jump-out or it will damage the command board.

Command board's 4 PIN interface's definition of VER-C edition is shown in the following chart 9-6:

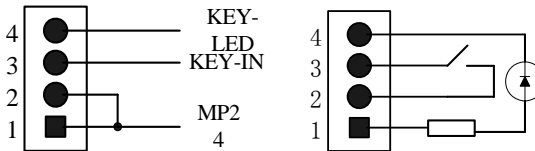

Chart 9-6 Command board's 4 PIN interface's definition and external connection of VER-C edition

4 PIN interface of VER-C edition has been modified. Getting rid of GND means the avoidance of the user's miss-operation to cause the damage of the board due to the short circuit. The meaning of signals in Chart 9-5 and Chart 9-6: MP24 (24V Power), KEY-IN (Button input signal), KEY-LED (Button light output), GND (0V).

3. Definition of input and output interface

There are 24 instruction inputs, 21 light outputs in each of CCB. When the number of floor is over 16 and the command board adopts concatenation, the command board 2 only uses input 16 and output 16 (only use for floor input and corresponding light output) .Definition according to the order is listed as follows :

1) Command input

Sequence number (n)	Corresponding interface	Definition	Instruction
1	JP1	Floor 1 button input	Input signal corresponds to floor(16+n) button input for command board 2
2	JP2	Floor 2 button input	
3	JP3	Floor 3 button input	
4	JP4	Floor 4 button input	
5	JP5	Floor 5 button input	
6	JP6	Floor 6 button input	
7	JP7	Floor 7 button input	
8	JP8	Floor 8 button input	
9	JP9	Floor 9 button input	
10	JP10	Floor 10 button input	
11	JP11	Floor 11 button input	
12	JP12	Floor 12 button input	
13	JP13	Floor 13 button input	
14	JP14	Floor 14 button input	
15	JP15	Floor 15 button input	
16	JP16	Floor 16 button input	
17	JP17	Door opening button input	
18	JP18	Door closed button input	
19	JP19	Door opening delay button	

Sequence number (n)	Corresponding interface	Definition	Instruction
		input	
20	JP20	Nonstop button input	
21	JP21	Motorman button input	
22	JP22	Reversing direction button input	
23	JP23	Running independently button input	
24	JP24	Fireman input	

2) Light output:

sequence number (n)	corresponding interface	definition	explanation
1	JP1	Floor 1 show output	Input signal corresponds to floor(16+n) display for command board 2
2	JP2	Floor 2 show output	
3	JP3	Floor 3 show output	
4	JP4	Floor 4 show output	
5	JP5	Floor 5 show output	
6	JP6	Floor 6 show output	
7	JP7	Floor 7 show output	
8	JP8	Floor 8 show output	
9	JP9	Floor 9 show output	
10	JP10	Floor 10 show output	
11	JP11	Floor 11 show output	
12	JP12	Floor 12 show output	
13	JP13	Floor 13 show output	
14	JP14	Floor 14 show output	
15	JP15	Floor 15 show output	

sequence number (n)	corresponding interface	definition	explanation
16	JP16	Floor 16 show output	
17	JP17	Door opening show output	Invalid for command board 2
18	JP18	Door closed show output	
19	JP19	Door opening delay show output	
20	JP20	Nonstop show output	

Cautions:

- 1) In order to protect communication signals from external disturbance, we advise to use STP for communication connection;
- 2) Connect strictly according to terminal signal, and insert the button firmly;
- 3) The two terminals of the command board are the same interface apparatus, so when in parallel connection of the command board, pay attention not to wrongly connect.

9.3 Direction for use of HCB

HCB is one of important interfaces that are used to connect NICE3000 controller to users. HCB can accept user’s call-up and show lift’s current floor, running direction and so on. At the same time HCB can be used for car cage displaying panel (the detail is shown in section 9.3.3).

HCB is diversified. In order to meet all kinds of needs, it is classified into several different forms, whose types are: MCTC-HCB-B no display output hall call; MCTC-HCB-F vertical dot-matrix hall call; MCTC-HCB-H and MCTC-HCB-J. horizontal dot-matrix hall call. We will only introduce the using method and attention items of MCTC-HCB-H, MCTC-HCB-F, and

MCTC-HCB-J.

9.3.1 Direction for use of MCTC-HCB-A

1. Appearance and size (Shown as Chart 9-8)

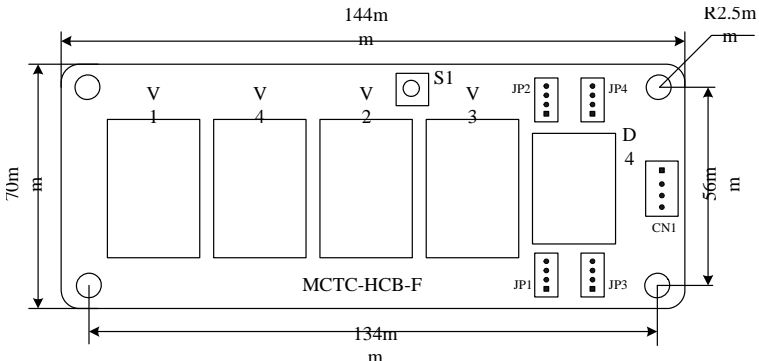

Chart 9-9 Installation size of MCTC-HCB-F

2. Direction for installation and using

1) Floor address setting and installation mode

A) Floor address setting: Press button S1 it will show the setting floor, and release the button for 4s it will return to show the current floor of the car cage. If you keep pressing the button for more than 4s, it will get into the state of resetting the floor. Each time you press the button, it will add 1 to the number of the floor. If you keep pressing the button S1, the information of the floor will add 1 continuously and the maximum setting value is 40. If there's no pressing in the continuous 4s, it will store the information of the floor where the displaying panel is in, and twice shining of the floor information indicates the successful storage. After 4s it will return to display the current floor where the car cage is in.

If the floor information setting is 0, it is car cage display panel;

The floor address is valid floor number (based on the leveling plate), increasing from the bottom to the top and not related to the actual floor number.

For example: One building has two floors underground, and 10 floors above. Among these, Floor 3 and Floor 4 are service floors. So the setting of the dial switch's floor address is as follows: The second floor underground is setting as 1, the first floor underground is setting as 2, and first floor above the ground is setting as 3, and the second floor above the ground is setting as 4. If there's leveling plate between the third floor and the fourth floor, they are setting separately as 5 and 6, meanwhile, the floors above the fifth floor are setting as 7, 8, 9...; if there's no leveling floor between the third floor and the fourth floor, jump through it, and the floors above the fifth floor are setting as 5, 6, 7....

B) Plug connection port of locked lift switch and fire switch separately into JP1 and JP2, and plug connection port of button of up running and down running separately into JP3 and JP4.

C) Plug connection port used for Modbus communication into CN1.

Cautions:

- ① Do not set hall call floor address as 0;
- ② In order to protect communication signals from external disturbance, we advise to use STP for communication connection;
- ③ It is better to use Shielded cable for signal line of communication;
- ④ Connect strictly according to terminal signal, and screw down

2) Definition of input and output

Terminal Name	Function Definition
JP1	Switch Interface of locked lift, pin 2、3 are switch connection pins, pin 4 is lift lock indicator output

Terminal Name	Function Definition
JP2	Switch Interface of fire fighting , pin 2 、 3 are switch connection pins, pin 4 is lift lock indicator output
JP3	Calling button interface of up running , pin 2 、 3 are switch connection pins, pin 1 、 4 are power supply pins, for controlling button light
JP4	Calling button interface of down running , pin 2 、 3 are switch connection pins, pin 1 、 4 are power connection pins, for controlling button light
CN1	Use for communicating with Modbus , pin 2、 3 of 4Pin interface are for communication, pin 1、 4 are for power connection

The specific definition of 4 PIN is shown in Chart 9-9. The means of marks in the chart: MP24 (24V Power), KEY-IN (Button input signal), KEY-LED (Button light output), GND (0V).

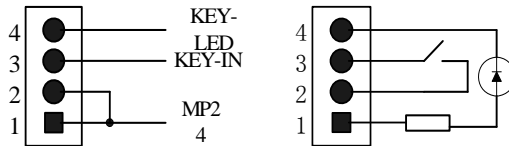

Chart 9-10 Interfaces' definition and external connection method of 4 PIN

3) Instruction of plugs

Plug Name	Function Definition
JP1	Setting of matched resistance to the terminal of MOD main line
JP2	Testing terminal, setting as "OFF" in application

J1 setting: Set the matched resistance to the terminal according to the actual needs. Generally it's only needed to set the J1 plug with the floor address 1 as "ON". Other floors needn't set, which means "OFF".

4) Dot-matrix display instruction

There are four dot-matrix modules in MCTC-HCB-F, they are V1, V2, V3, and V4 with the color red. The specific displaying content and meaning are as follows:

A) Dot-matrix V1

Showing information	Meaning
Up arrowhead	Lift in the state of up running
Down arrowhead	Lift in the state of down running
Arrowhead moving	Lift in the state of running
Showing stabilization of arrowhead	Lift is stopping at some floor
Arrowhead no showing	Lift in stopping state
“⊖”	Error Lift can't be used

B) Dot-matrix V2

Showing information	Meaning
Display Arabic number stably	Floor information high bit
Shining block quenches	Lift is in the floor lower than Floor 10 or it stops working

C) Dot-matrix V3

Showing information	Meaning
Display Arabic number stably	Floor information low bit
Shining block quenches	Lift stops working

D) Dot-matrix V4 (Reserved)

Showing information	Meaning
Display Arabic number stably	Floor information reserved bit (If some users need to display the floor as “12A” or “12B”, etc. Dot-matrix V4 displays “1”, dot-matrix V2 displays “2”, dot-matrix V4

	displays "A")
Shining block quenches	No lift reserved bit or the lift stops working

Note: Dot-matrix V4 is reserved in the normal condition. When the users non-standard need three dot-matrixes to display the floors, it will add this dot-matrix;

Inspection: When the lift is in inspection running, hall displaying panel V2, V3 scrolling display "INS" and the current floor car cage in.

9.3.2 Direction for use of MCTC-HCB-H

1. Appearance and size (Shown as Chart 9-10)

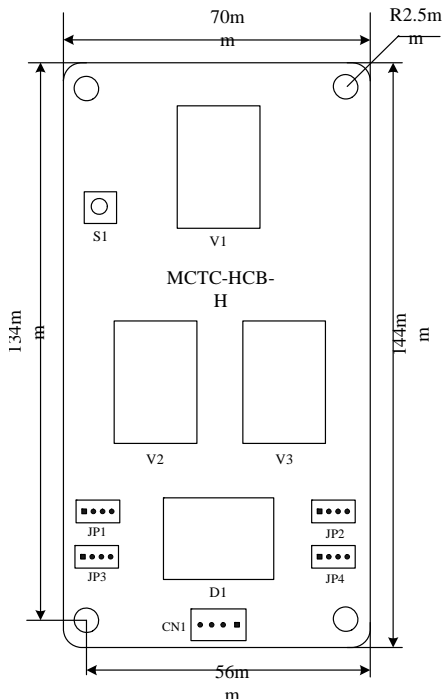

Chart 9-10 Installation size of MCTC-HCB-H

MCTC-HCB-H is the advanced product of MCTC-HCB-A. It possesses all the function of MCTC-HCB-A, and optimizes the hardware: The setting of floor is changed from the dialing code setting to the button setting.

2. Direction for installation and using

The floor addresses setting and installation mode, input and output definition, and plug definition are all the same with MCTC-HCB-F; there are only V1, V2 and V3 three dot-matrixes in the dot-matrix displaying of MCTC-HCB-H, without V4 comparing with MCTC-HCB-F. Others are all the same with MCTC-HCB-F. Details are listed in section 9.3.2.

9.3.3 Direction for use of MCTC-HCB-J

The function and the application of **MCTC-HCB-J** exactly the same as **MCTC-HCB-H**, The only difference is that communication interface terminal is used in green, Spacing of 5.08mm terminal (The same as **MCTC-HCB-A**)

9.4 Weighing transducer (LDB)

Technical parameters of weighing transducer		
System working voltage		DC24V±15%
Best effective distance		15~30mm (Specification refers to chart 9-7-3)
Minimum distance with full load		15mm Specification refers to chart 9-7-3)
Best effective distance with no load		25mm (Specification refers to chart 9-7-3)
Transducer's connection wiring	Red line	+24V
	Black line	0V
	Green line	0~10V Signal wiring
Transducer's size	Diameter	24mm

	Height	87mm
--	--------	------

Users can choose to equip weighing board (MCTC-LDB-A) for providing the system with the signals of light load, full load and over load and complete to compensate analog weight, in order to improve stability of lift running.

Installation Mode:

It's recommended to be installed into the bottom of the car cage.

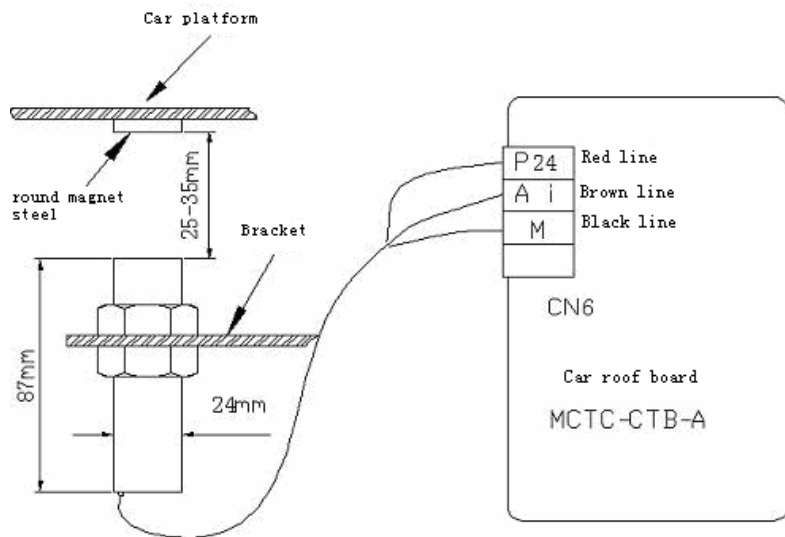

Chart 9-12 Installation sketch of weighing transducer (Transducer connected to the car top board)

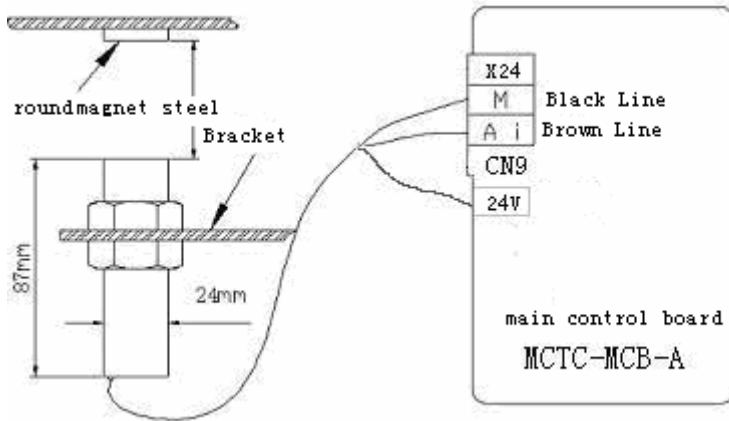

Chart 9-13 Installation sketch of weighing transducer (Transducer connected to the main control board)

Attention items:

The installation position should be close to the middle of the car cage as possible as it can.

The square porcelain steel with pasted paper is the working surface, and it should be opposite to the transducer.

If there's no voltage outputting after installation, please try to change the polarity of the square porcelain steel.

9.5.3 The relationship chart between the distance (mm) from top of the weighing transducer to the square porcelain steel and transducer's outputting voltage (V):

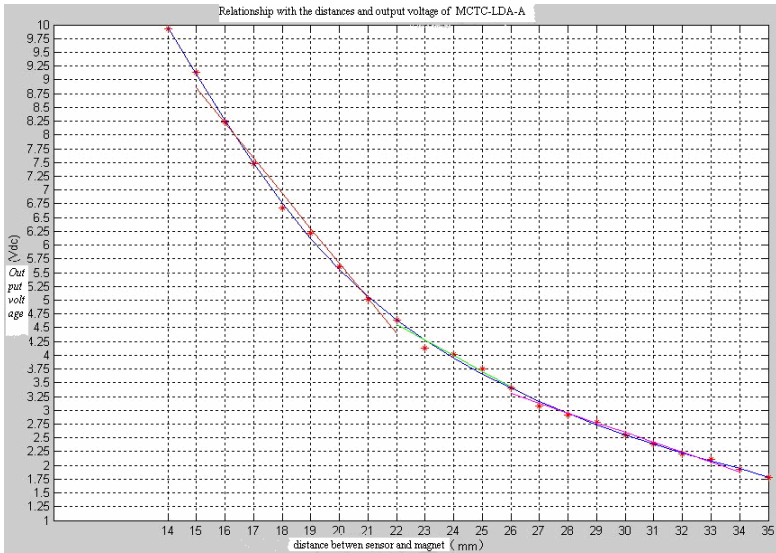

Chart 9-14 Weighing transducer's outputting voltage

User can choose the best install distance according to the car cage's compression deformation from no load to full load and choose the maximum distance from it.

For example: If one customer's compression deformation is 5mm, the user can analyze according to chart9-7-3: ①、If the distance of no load is 21mm, and the transducer's outputting voltage is 5.25V, when the distance of full load is 16mm, transducer's outputting voltage will be 8.25V, and the change of the voltage from no load to full load is 3V. ②、 If the distance of no load is 35mm, and the transducer's outputting voltage is 1.75V, when the distance of full load is 30mm, transducer's outputting voltage will be 2.5V, and the change of the voltage from no load to full load is 0.75V. Through the analysis of ① and ② we can conclude that the resolution of ① is fourth than that of ②. Obviously the higher resolution, the better it will be.

9.6 Other optional components

9.6.1 Operation board and communication cable(OPR、 OPL)

Operation board (OPR): MCTC-OPR-A.

Communication cable (OPL): MCTC-OPL0150, 0150 standing for 15m length.

Connection cable: MCTC-CCL0150, 0150 standing for 15m length.

If users need panel matched cable, they can choose the scope of cable with length 2m, 5m, 15m, 30m, 50m, and 100m.

9.6.2 Others

To coordinate with the use of NICE 3000 system, Suzhou Monarch Control Technology Corp., Ltd. provides other accessories such as group control board (MCTC-GCB-A), short message control board (MCTC-IE-A), PDA adjusting machine (MCTC-PDA-A), Serial transferring to parallel control board (MCTC-HPB-A), small zone monitoring interface board (MCTC-BMS-A) and so on. If you need any of them, please contact with the suppliers.

NOTE:

Function code	Setting value	Function code	Setting value	Function code	Setting value	Function code	Setting value
F -	_____	F -	_____	F -	_____	F -	_____
F -	_____	F -	_____	F -	_____	F -	_____
F -	_____	F -	_____	F -	_____	F -	_____
F -	_____	F -	_____	F -	_____	F -	_____
F -	_____	F -	_____	F -	_____	F -	_____

Date Month Year

Location:
