

Contents

PREFACE	I
CHAPTER 1 SAFETY AND PRECAUTIONS	- 2 -
1.1 SAFETY PRECAUTIONS	- 2 -
1.2 ATTENTION ITEMS	- 6 -
CHAPTER 2 PRODUCT INFORMATION	- 10 -
2.1 NAME DESIGNATION RULES AND NAMEPLATE	- 10 -
2.2 MAIN MODELS OF NICE 1000 INTEGRATED CONTROLLER SERIES:	- 11 -
2.3 TECHNICAL SPECIFICATION	- 11 -
2.4 PRODUCT APPEARANCE	- 13 -
2.5 DAILY MAINTENANCE OF CONTROLLER	- 16 -
CHAPTER 3 INSTALLATION AND WIRING	- 20 -
3.1 SYSTEM CONFIGURE INTRODUCTION	- 20 -
3.2 MECHANICAL INSTALLATION	- 20 -
3.3 ELECTRIC INSTALLATION AND WIRING	- 21 -
CHAPTER 4 INSTRUCTION OF DEBUGGING TOOLS	- 34 -
4.1 DEBUGGING TOOLS FOR NICE 1000	- 34 -
4.2 OPERATION PANEL DESCRIPTION	- 34 -
CHAPTER 5 FUNCTION PARAMETERS TABLE	- 40 -
5.1 DESCRIPTION OF FUNCTION PARAMETERS.....	- 40 -
5.2 FUNCTION PARAMETER TABLE	- 41 -
CHAPTER 6 FUNCTIONAL PARAMETER SPECIFICATION	- 78 -
6.1 GROUP F0 BASIC FUNCTION GROUP.....	- 78 -
6.2 F1 GROUP MOTOR PARAMETERS	- 80 -
6.3 GROUP F2 VECTOR CONTROL PARAMETER.....	- 84 -
6.4 GROUP F3 RUNNING CONTROL PARAMETERS.....	- 86 -
6.5 GROUP F4 POSITION PARAMETERS.....	- 91 -
6.6 F5 GROUP TERMINAL INPUT FUNCTION PARAMETERS	- 94 -
6.7 GROUP F6 LIFT BASIC PARAMETERS	- 110 -

6.8 GROUP F7	TERMINAL OUTPUT FUNCTION PARAMETER	- 114 -
6.9 GROUP F8	REINFORCE FUNCTION PARAMETERS	- 117 -
6.10 GROUP F9	TIME PARAMETERS.....	- 120 -
6.11 GROUP FA	KEYBOARD SETTING PARAMETERS.....	- 121 -
6.12 GROUP FB	DOOR FUNCTION PARAMETERS	- 127 -
6.13 GROUP FC	PROTECTION FUNCTION PARAMETERS.....	- 131 -
6.14 FD GROUP	RESERVED PARAMETERS	- 133 -
6.15 FE GROUP	LIFT FUNCTION SETTING PARAMETERS.....	- 133 -
6.16 GROUP FE	FACTORY PARAMETERS (RESERVED)	- 139 -
6.17 GROUP FP	USER PARAMETERS.....	- 139 -
CHAPTER	TYPICAL SYSTEM APPLICATION & ADJUSTING.....	- 142 -
7.1	ELEVATOR ADJUSTING	- 142 -
7.2	SYSTEM TYPICAL APPLICATION.....	- 143 -
CHAPTER 8	FAULTS – CAUSES - REMEDIES	- 154 -
8.1	FAULT CLASSIFICATION.....	- 154 -
8.2	FAULT DETAILS & REMEDIES	- 155 -

Preface

NICE 1000 is the elevator integrated controller, which is under the research and development of SUHZOU MONARCH CONTROL TECHNOLOGY Co., Ltd. With the core of NICE 1000, the elevator electrical system adapts complete parallel modes for signal transfer and combines the advantage of high stability, easy using, free of debugging, all that makes NICE 1000 more perfectly suitable for villa elevators and freight elevators.

NICE 1000 integrated controller has the following features:

- Structural Features:

- 1) Compact structure

Integrated structure saves space for the control board, and reduces the size of the control cabinet.

- 2) 27 input points for switch signal

There are three strong electric input circuits in switch signal input; they can connect the safety circuit, hall door lock circuit, cage door lock circuit directly into the control board. It saves the links of the contactor, and reduces the fault points. Signals directly inputted into the main control board make the wiring in the control board more clear. It saves a lot of time in making the control cabinet and enhances the possibility of success, saving more than one in five control board wirings than those traditional freight lifts.

- 3) 20 points for buttons inputting and lights outputting

The main control board has 20 button input points. While there's no added point, it can fulfill the full selective application for 7 floors, and single selective application for 9 floors.

All the button points can be flexible defined. According to the required functions and the application situation, they can be flexible distributed. All the button points are shared by the inputting and outputting. One signal wiring fulfills the button's signal collection and indicator's outputting, greatly reducing the numbers of the wirings those buttons occupied.

- 4) fast speed counter port of encoder,

Corresponding frequency which reaches as high as 80 kHz can satisfy the encoder inputting with all wirings. Through the installation of different PG cards, synchronous motor can suit for the encoders of sine cosine and UVW types.

5) 24 points for relay output

The output groups are separated definitely. Each terminal's function can be flexibly defined. The unique design assures the complete automatic changeover ways of the power when there's power failure emergency and confirms the safety running of the villa elevator. It uses relay output to display output, and the code ways can be selected. Users can equip the display panel depends on their needs.

6) Expansion cards

It can expand 3 output points, 6 button input and output points, 1 MODBUS communication terminal, and 1 analog input terminal.

The expansion of the expansion cards for the button's input and output points enables NICE 1000 to cover all the application conditions of the freight elevator and villa elevator. The analog's input terminal can be used for the input and output of car cage load.

● Function Features:

- 1) Abundant door function setting can satisfy the goods lift's needs for the variety of the door control.
- 2) Practical and reliable power failure emergency application scheme, which can set passengers free automatically when power failure occurs.
- 3) The default is popularization, reducing the setting of vary application as much as possible.
- 4) After the appropriate settings in the factory, it can realize the zero parameter debugging on the spot.
- 5) Direct stopping function makes it more comfortable to take and more effective to run.
- 6) Over short floor running without special debugging.
- 7) Supplemented by the pre-opening module, it can easily fulfill the

functions of pre-opening and re-leveling after opening.

Instruction of NICE 1000 Elevator integrated controller:

sequence	Function	Remark	Sequence	Function	Remark
Basic Function					
1	Maintenance running	Standard	27	Repeating opening the door	Standard
2	Direct stopping	Standard	28	Door opening signal to open the door at door zone	Standard
3	Self-rescue leveling	Standard	29	Hall opening	Standard
4	Emergency rescue running	Standard	30	Pre-opening of door	Standard
5	Motor parameters self-tuning	Standard	31	Open the door and re-leveling	Standard
6	Shaft parameters self-tuning	Standard	32	Full load bypass	Standard
7	Staircase lock function	Standard	33	Overload protection	Standard
8	Automatic back to the base floor	Standard	34	Attendant operation	Standard
9	Lights off for energy-saving	Standard	35	Direction reversing	Standard
10	Service floor setting for the front and back doors	Standard	36	Fire emergence back to base floor	Standard
11	Service floor setting	Standard			Standard

sequence	Function	Remark	Sequence	Function	Remark
12	Self-tuning for car location	Standard	37	Independent running	Standard
13	Jumping floor display	Standard	38	Reversal protection running	Standard
14	Cancel the wrong command	Standard	39	Anti-skid protection	Standard
15	Reverse canceling	Standard	40	Contactors adhesion protection	Standard
16	Automatic door switch	Standard	41	Motor Over-current protection	Standard
17	Door keep opening time setting	Standard	42	Power source over-voltage protection	Standard
18	Plural hall call in the same floor	Standard	43	Motor overload protection	Standard
19	Door fault protection	Standard	44	Encoder fault protection	Standard
20	Open-through door independent control	Standard	45	Fault record	Standard
21	Door machine Artificial selection	Standard	46	Weight compensation signal	Standard
22	Reverse cancellation	Standard	47	Pre-torque setting	Standard
23	Automatic door switch	Standard	48	Full selective	Standard
24	Door keep opening	Standard	49	Communication state	Standard

sequence	Function	Remark	Sequence	Function	Remark
	time setting			surveillance	
25	Plural hall call in the same floor	Standard	50	Reduce the pick-up for outside hall calls	Standard
26	Door fault protection	Standard	51	Lock jump-out detection	Standard
Features					
52	The best curve generated automatically	Standard	56	Lock jump-out protection	Standard
53	Up selective	Standard	57	Short-circuit test against the earth	Standard
54	Down selective	Standard	58	Testing function	Standard
55	Call adhesion judgment	Standard	59	Force reducer monitoring function	Standard



Safety and Precautions

Chapter 1 Safety and Precautions

Safety definition:

There are two kinds of safety items in this manual:



Failure to follow the instructions will result in death or serious injury



Failure to follow these instructions can result in medium hurt or equipment damage

Please read this manual carefully and operate strictly according to the safety tips while installing, debugging, maintaining the system. MONARCH company is free of charge to any damage or loss caused by any operations that not performed according to the requirements.

1.1 Safety Precautions

1.1.1 Before Installation



- Do not install in the condition of water seepage in the control system, components scarcity or damage while opening the case!
- Do not install while the packing list is not in the accordance with the products!



- Please uplift and drop gently in the portage otherwise the equipment will be damaged!
- Do not use any controller that is damaged or not complete. Cautious for the danger of getting hurt!
- Do not touch the elements of the controller with your hand, otherwise the static electricity hurt may be caused!

1.1.2 During Installation

⚠ Danger

- Please mount the controller on incombustible surface like metal, and keep away from flammable substances! Otherwise it may cause fire!
- Do not twist the fixing bolts of the components, especially the bolts with red marks!

⚠ Note

- Do not let wiring terminal or screw enter the controller, otherwise the controller will be damaged!
- Install the controller where there's less shaking and no direct sunshine.

1.1.3 During Wiring

⚠ Danger

- Only the qualified electrical engineer can perform the wiring, otherwise there will be danger of electric shock.
- A circuit breaker must be installed between the power supply and the controller; otherwise there will be danger of fire.
- Wiring can only be done after the power is cut off; otherwise there will be danger of electric shock.
- Please connect the controller to the ground according to the requirements, otherwise it will be dangerous

⚠ Danger

- Do not connect the input current with the controller's output terminals (U, V, W). Please note the marks and do not connect the wrong wires otherwise the controller may be damaged!
- Ensure the wiring meet the EMC requirements and the local safety standard. The wire size shall be determined according to the manual, otherwise accidents may occur!
- Brake resistor can never be connected between the DC bus terminals (+) and (-) directly, otherwise fire may occur!

Danger

- Encode connection must use Shielded line, shielding layer must be one side connected to earth reliably!
- Communication wires must use STP with the lay of 20mm~30mm, shielding layer must be connected to earth!

1.1.4 Before Power-on**Note**

- Please confirm the mains voltage level is consistent with that of the controller ;the input (R,S,T) and output (U,V,W) wirings are correct; and check if there is any short circuit in peripheral circuit and if the wiring is fixed and fast; otherwise the controller may be damaged!
- Ensure the synchronous motor has done the dynamic self-learning and try to run the motor before restoring wire ropes.
- No part of controller needs further dielectric strength testing since it has been done in the factory; Otherwise accidents will occur!

Danger

- Mount the cover plate properly before power-on the controller; otherwise there will be danger of electric shock!
- All the external parts wirings must be connected according to the instruction of this manual, otherwise accidents may occur!

1.1.5 Upon Power-on**Danger**

- Do not open the cover of the controller after power-on, otherwise there will be danger of electric shock!
- Do not touch the controller and its circuit with wet hand; otherwise there will be danger of electric shock.
- Do not touch the controller terminals; otherwise there will be danger of electric shock.
- At power-on, the controller will perform the security check of the external heavy-current circuit. At this time do not touch U, V, W terminals of controller or the wirings terminals of the motor; otherwise

there will be danger of electric shock!

 **Danger**

- If parameter identification is required, please pay attention that the rotating motor may injure people, otherwise accident may occur!
- Do not change the factory settings; otherwise the equipment may be damaged!

1.1.6 Running

 **Danger**

- Do not touch the fan and the discharging resistor to check the temperature, otherwise burning will occur!
- Only the qualified technician can check the signal while it's running. Otherwise there will be danger of personal injury or equipment damage!

 **Note**

- Do not let objects fall in a running controller; otherwise the controller may be damaged!
- Do not start and stop the controller by on/off of the contactor, otherwise the controller may be dangerous.

1.1.7 Maintenance

 **Danger**

- Please do not repair or maintain the controllers with power on, otherwise there will be danger of electric shock!
- Ensure the repair and maintenance of the controller is operated in the condition that the controller voltage is below AC36V, two minutes after the power is switch-off. Otherwise the residual Charge in the capacitor will injure people.
- Only qualified electrical engineer can repair or maintain the controller, otherwise there will be danger of human injury or damaging the equipment.
- Reset the parameters after changing the controller; all the insets must

be unplugged while the power is switch-off!

1.2 Attention Items

1.2.1 Motor insulation check

When the motor is used for the first time, or reused after storing for a long time, or in a regular checkup, the user must check the insulation of the motor to prevent the poor insulation of the windings of motor from damaging the controller. The motor connection must be divided from the controller during the insulation check. It is recommended to use a 500V Mega-Ohm-Meter to check and the insulation resistance shall not be less than 5MΩ.

1.2.2 Thermal Protection of Motor

If the rated capacity of the motor selected is not matching that of the controller, especially when the rated power of the controller is bigger than that of the motor, make sure to adjust the parameters for motor protection inside the controller or to install a thermal relay to the motor to guarantee the protection to the motor.

1.2.3 Motor Heat and Noise

Since the output voltage of the controller is in PWM wave with some harmonic wave, the temperature may raise, the noise and vibration may increase compared with the controller running at main frequency.

1.2.4 Pressure-sensitive Device or Capacitor at the Output Side of the Controller

Because the controller outputs PWM wave, the capacitor used for improving power factor and pressure-sensitive resistor used for lightning-proof shouldn't be installed at the output side of the controller. Otherwise the controller may have transient over-current and may be damaged.

1.2.5 Switches Used at the Input and Output terminal of the Controller

If the contactor is required to be installed between the controller input terminal and the power supply, it is prohibited to start or stop the controller with the contactor. If the switches like contactors are connected between the output terminal and the motor, make sure to start and stop the controller when the controller has no outputting, otherwise the modules in the

controller may be damaged.

1.2.6 Usage out of the Range of Rated Voltage

The NICE1000 controller shall not be used out of the specified range of operation voltage. Otherwise the internal components of the controller may be damaged. If needed, please use corresponding voltage regulation device to change the voltage.

1.2.7 Lightning Strike Protection

There are lightning protection devices inside the controller, but the user should install other lightning protection device at the front end of the controller if lightning strike occurs frequently.

1.2.8 Altitude and De-rating

When the altitude is higher than 1000m, the cooling effect of consult is deteriorated because of the rarefaction of air, then it is a necessity to derate the use of controller and please contact our company for detailed technical support in this circumstance.

1.2.9 Cautions for Scrap of controller

The electrolytic capacitors in the main circuits and PCB may explode when they are burned and poisonous gas may be generated when the plastic parts are burned. Please dispose the controller as industrial rubbish.

1.2.10 About Applicable Motor

- 1) The controller is applicable to squirrel-cage asynchronous motor and AC permanent-magnet synchronous motor. Please be sure to select the applicable controller according to the Data plate of the motor.
- 2) The controller has already been configured with default parameters which is applicable to squirrel-cage Asynchronous motor. To perform the motor parameter identification according to the actual conditions will promote the operation effect. Synchronous motor must carry out parameter tuning.
- 3) The output part of controller should not be short. Otherwise the controller may alarm or be damaged. Therefore, before Power-on, we must execute short-circuit-test for new elevator. Please make sure that the controller be cut from the testing parts when the

testing is undergoing..



Product information

Chapter 2 Product information

2.1 Name Designation Rules and Nameplate

2.1.1 Applies to Asynchronous/ Synchronous motor:

Name designation rules:

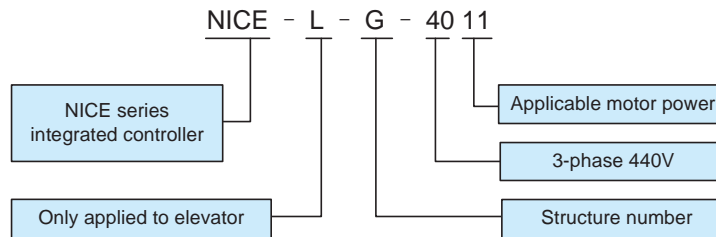

Structure number G presents for Asynchronous motor;

Structure number V presents for Synchronous motor.

2.1.2 Applies to Asynchronous/ Synchronous motor:

Name designation rules:

Asynchronous motor nameplate:

MODLE	NICE-L-G-4015
POWER	15kW
INPUT	3PH AC380V 36A 50Hz/60Hz
OUTPUT	3PH AC380V 33A 0~90Hz
S/N	
Suzhou MONARCH Control Technology Co.,Ltd.	

Synchronous motor nameplate:

MODLE	NICE-L-V-4015
POWER	15kW
INPUT	3PH AC380V 36A 50Hz/60Hz
OUTPUT	3PH AC380V 33A 0~90Hz
S/N	
Suzhou MONARCH Control Technology Co.,Ltd.	

2.2 Main models of NICE 1000 integrated controller series:

Model	Input Voltage	Power Capacity(KVA)	Input Current (A)	Output Current(A)	Adaptable Motor(KW)
NICE-L-G/V-2002	Three phase 220V	4.0	13.2	9.6	2.2
NICE-L-G/V-2003	Range: -15%~20%	5.9	17.0	15.6	3.7
NICE-L-G/V-4002	Three phase 380V Range: -15%~20%	4.0	6.5	5.1	2.2
NICE-L-G/V-4003		5.9	10.5	9.0	3.7
NICE-L-G/V-4005		8.9	14.8	13.0	5.5
NICE-L-G/V-4007		11.0	20.5	18.0	7.5
NICE-L-G/V-4011		17.0	29.0	27.0	11
NICE-L-G/V-4015		21.0	36.0	33.0	15
NICE-L-G/V-4018		24.0	41.0	39.0	18.5
NICE-L-G/V-4022		30.0	49.5	48.0	22
NICE-L-G/V-4030		40.0	62.0	60.0	30

The products with the input voltage 220V correspond to 3- phase inputting. If the input voltage is single phase, it shall match with a larger frequency. For example, NICE-L-G-2003 can be used in the situation that single phase inputting 220V to drive the motor with 2.2 KW.

2.3 Technical Specification

Item		Specification
Specification	Maximum frequency	90Hz
	Carrier frequency	0.5k~16k (Hz); Carrier frequency can be adjusted automatically according to the load characteristic.
	Control mode	Open loop vector control (SVC)/ Closed loop vector control (VC)

Item	Specification	
Start torque	Type G: 0.5Hz / 180% (SVC), 0Hz/200% (VC)	
Speed adjustment range	1 : 100 (SVC)	1 : 1000 (VC)
Speed stabilization precision	±0.5%(SVC)	±0.05%(SVC)
Torque control precision	±5%(VC)	
Overload capability	150% rated current for 60 seconds; 200% rated current for 1 second.	
Motor tuning	Asynchronous motor: Static tuning Synchronous motor: Initial angle tuning	
Distance control	Flexible adjustment for leveling direct stop	
Speed up and speed down curve	N curves can generate automatically.	
Re-leveling	Leveling re-adjustments after the car load changes	
Compulsive deceleration	New and reliable compulsive deceleration function helps to identify the deceleration shelf automatically.	
Well self-tuning	32-bit data, record the well position accurately.	
Leveling adjustment	Flexible and easy leveling adjustment function	
Starting torque compensation	considerate weighing self-learning	
Testing function	Convenient ways to realize many functions for elevator adjusting.	
Failure protection	Provide 53 variety kinds of protection such as electrify short circuit survey, in-out lack phase protection, over current protection, encoder protection etc. A complete elevator fault-dealing system	
Electrify peripheral	Implement electrify and do peripheral equipment detection	

Item		Specification
	equipment safety self-examination	like grounding, short circuit etc.
	State monitor	According each feedback signal to judge elevator work state, ensure the elevator work effectively.
	Digital input	24 Digital input terminal, specification:24V, 5mA
	Analog data input	Expansion board offers analog data input , inputting voltage range: 0V~10V
Input/output characteristic	Communication terminal	Expansion board offers Modbus communication
	Output terminal	24 relay output
	Encoder interface	Default apply increment push-pull output and plough collector output; MCTC-PG-D apply U,V,W type encoder; MCTC-PG-E apply sine cosine increment encoder
	Operation panel	5-bit LED display, show parameters of function, running speed, bus voltage, etc.
	Small keyboard	Well self-tuning
Display and keypad	State monitoring	Monitoring parameters in different states
	Altitude	Lower than 1000m
	Ambient temperature	-10℃~ +40℃ (ambient temperature is within 40℃~50℃ , and de-rating is required)
Application environment	Humidity	Less than 95% RH, without condensation
	Vibration	Less than 5.9m/s ² (0.6g)
	Storage temperature	-20℃ ~ +60℃

2.4 Product Appearance

The controller has three types of size, listed in the following diagram:



Model	Adaptable Motor (KW)	Structural Type
NICE-L-G/V-2002	2.2	SIZE-C
NICE-L-G/V-2003	3.7	SIZE-C
NICE-L-G/V-4002	2.2	SIZE-C
NICE-L-G/V-4003	3.7	SIZE-C
NICE-L-G/V-4005	5.5	SIZE-C
NICE-L-G/V-4007	7.5	SIZE-D
NICE-L-G/V-4011	11	SIZE-D
NICE-L-G/V-4015	15	SIZE-D
NICE-L-G/V-4018	18.5	SIZE-E
NICE-L-G/V-4022	22	SIZE-E
NICE-L-G/V-4030	30	SIZE-E

Note: The products with other frequency such as over 37KW are not listed because of seldom using. If you need these products please contact us for details.

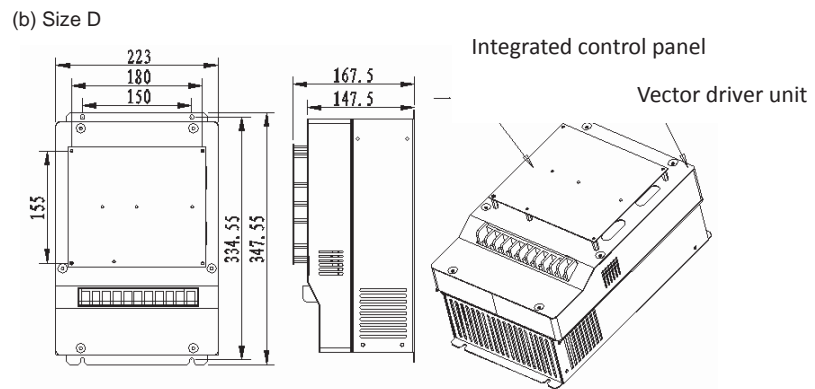
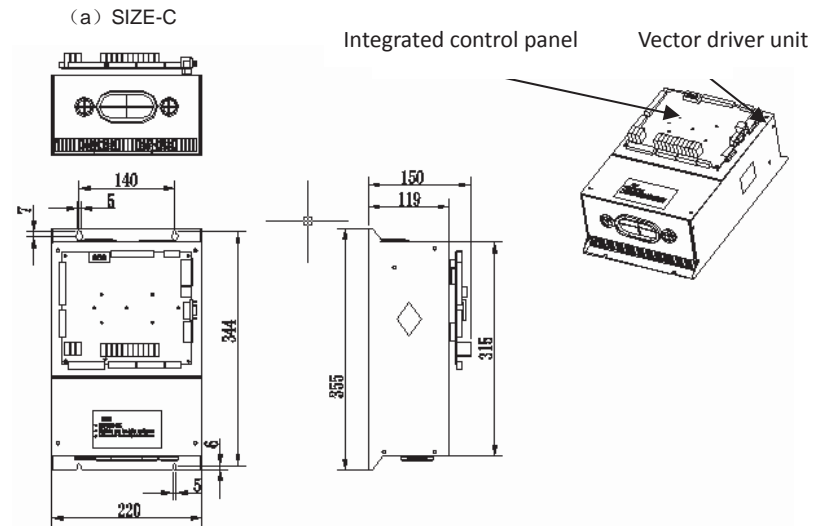

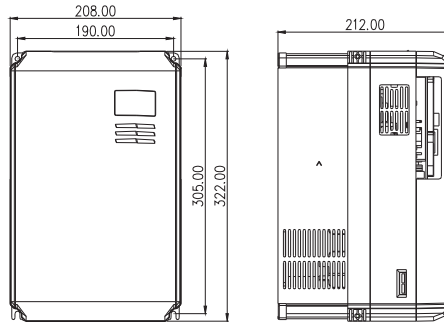

(c) SIZE-E

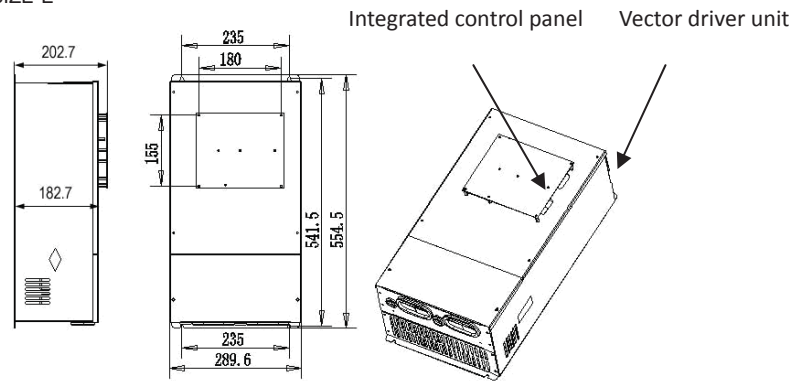

2.5 Daily Maintenance of Controller

Since the influence of ambient temperature, humidity, dust, and vibration, the components in controller may become aging and wearing, which will give rise to the occurrence of potential faults and reduce the life of controller. Therefore, it is quite necessary to do the work of daily maintenance of controller.



The filter capacitor still has high voltage after the power supply to the controller is switched off, so do not maintain or repair the controller until the bus voltage measured after 2 or 3 minutes with the multi-meter. The voltage must be lower than 36V.

2.5.1 Daily Maintenance

- 1) Daily checking items:
 - a) Check if there is any abnormal noise during the running of motor;
 - b) Check if there is any vibration of motor ;
 - c) Check if the installation environment of controller changes ;
 - d) Check if the cooling fan of controller works normally ;
 - e) Check if the controller is over heated.
- 2) Daily Cleaning:
 - a) Keep the controller in a clean status;
 - b) Clean the dust from the controller and prevent the dust especially the metal powder from entering the controller;
 - c) Clean the oil dirt in the cooling fan of the controller.

2.5.2 Periodical Checking

Periodically check the places that are hardly checked during the running.

- 1) Periodical Checking Items
 - a) Check the ventilation channels and clean them periodically;
 - b) Check if the screws are loosen;
 - c) Check if the controller is corroded;
 - d) Check if the input / output terminal has scratch marks;
 - e) Check the insulating in main circuit.

Note: Insulation test (use 500V Mega-Ohm-Meter) should be done separately after disconnecting the input power cables from the controller; or else, the controller will be damaged. Do not use the Mega-Ohm-Meter to test the insulation of control circuits. Dielectric strength test had been done at factory. Therefore, user need not do this test again.

2) Replacement of Wearing Parts

The wearing parts of controller mainly include the cooling fan and filtering

electrolytic capacitor. Their lifetime is closely related to the operating environment and maintenance.

General lifetime as follows:

Component	Lifetime
Fan	2 ~ 3 years
Electrolytic capacitor	4 ~ 5 years

The user can determine the year of replacement according to the operating time.

1) Cooling fan

Possible damage causes: shaft bearing attrition and blade aging.

Criteria: no crack on fan blade, no abnormal vibration noise at start.

2) Filtering electrolytic capacitor

Possible damage causes: high ambient temperature, big pulsating current due to frequent load fluctuation, electrolyte aging.

Criteria: no liquid leak, no protrusion of safety valve, electrostatic capacitance measurement, and insulation resistance measurement.

2.5.3 Controller Storage

The following points must be noticed in controller storage:

1) It is recommended to store the controller in its original packing box.

2) Long-term storage will cause deterioration of electrolytic capacitor. Therefore, controllers not in service for a long time must be powered for at least once within 2 years for testing purpose, at least for 5 hours ; in the test , the input voltage must be boosted gradually with voltage regulator to the rated value.



Installation and wiring

Chapter 3 Installation and wiring

3.1 System Configure Introduction

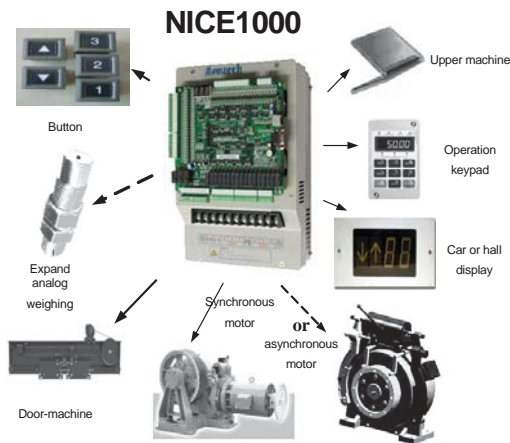

Fig. 3-1

3.2 Mechanical Installation

NICE 1000 controller installation size requirements:

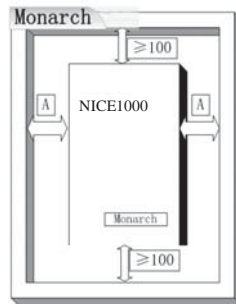

Fig. 3-2 controller installation size requirements

The unit in the figure is mm.

A shall be not smaller than 50mm for the controller of 22kW or above.

3.3 Electric Installation and Wiring

3.3.1 Using of External Device

Device	Position	Function
Air breaker	Front-end of input circuit	Cut off the power and provide short protection.
Contactora	between air breaker and controller	Switch on/off the controller; controlled by safe circuit.
AC input reactor	Controller input side	Improving the power factor of the input side; eliminate high frequency humorous wave in input side; eliminate current unbalance due to input phase unbalance;
DC reactor	Built-in as standard	Improving the power factor of the input side; eliminate high frequency humorous wave in input side; eliminate current unbalance due to input phase unbalance;
AC output reactor	Between controller output side and motor, and near controller	If the distance between the vector driver and the motor is longer than 100m, it is recommended to install the AC output reactor.

Selecting of External Device

Model	Air circuit breaker (MCCB) (A)	Contactora (A)	Conducting Wire of Main Circuit at the Input Side (mm ²)	Conducting Wire of Main Circuit at the Output Side (mm ²)	Conducting Wire of control circuit (mm ²)	Grounding wire (mm ²)
NICE-L-G/V-2002	20	16	4	4	1	4
NICE-L-G/V-2003	32	25	6	4	1	4
NICE-L-G/V-4002	16	10	4	4	1	4
NICE-L-G/V-4003	25	16	4	4	1	4
NICE-L-G/V-4005	32	25	4	4	1	4
NICE-L-G/V-4007	40	32	6	6	1	4

Model	Air circuit breaker (MCCB) (A)	Contact (A)	Conducting Wire of Main Circuit at the Input Side (mm ²)	Conducting Wire of Main Circuit at the Output Side (mm ²)	Conducting Wire of control circuit (mm ²)	Grounding wire (mm ²)
NICE-L-G/V-4011	63	40	6	6	1	4
NICE-L-G/V-4015	63	40	6	6	1	4
NICE-L-G/V-4018	100	63	10	10	1	4
NICE-L-G/V-4022	100	63	10	10	1	4
NICE-L-G/V-4030	125	100	16	16	1	4
NICE-L-G/V-4037	160	100	16	16	1	4
NICE-L-G/V-4045	200	125	25	25	1	4

3.3.2 Driving Brake Resistance (DBR)

NICE 1000 elevator integrated controller's motors with no more than 30 KW, have been equipped inside with driving brake unit. User just needs to connect external driving brake resistance. Motors with more than 30 KW need external driving brake unit and resistance.

Model	DBR Specification	Driving Brake Unit	
MCTC-DBR-2002	1100W,130Ω	Standard installation	Inside
MCTC-DBR-2003	1600W,90Ω		
MCTC-DBR-4002	600W,220Ω		
MCTC-DBR-4003	1100W,130Ω		
MCTC-DBR-4005	1600W,90Ω		
MCTC-DBR-4007	2500W,65Ω		
MCTC-DBR-4011	3500W,43Ω		
MCTC-DBR-4015	4500W,32Ω		
MCTC-DBR-4018	5500W,25Ω		
MCTC-DBR-4022	6500W,22Ω		
MCTC-DBR-4030	9000W,16Ω		

3.3.3 Electric wiring

Electric wiring include two parts: Controller main circuit terminal wirings and main control board wirings.

1) Main circuit connection and terminal function

a) main circuit:

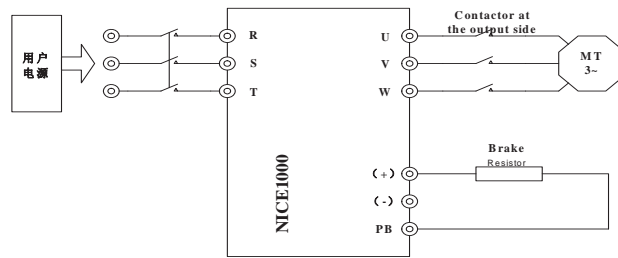

Fig. 3-3 Main Circuit Wiring

b) terminal function:

Terminal	Name	Description
R,S,T	3-phase power input terminal	Input 3-phase AC380V
(+),(-)	Positive and negative terminals of DC bus	Terminal of external brake unit for controller above 37KW.
P(+),PB	Terminals for brake resistor	For controller below 30kW(include 30kW) they are for brake unit
U,V,W	controller output terminal	Connect 3-phase motor
PE	Terminal for grounding	Grounding terminal

Note:

- ☆ Select the recommended resistor according to section 3.3.2.
- ☆ Controller output circuit grounding or short circuit is absolutely not permitted.
- ☆ Controller output cables of U, V and W should be in metal pipe with grounding, and divided or vertical with control circuit cables.
- ☆ If the cables between the motor and the controller are too long, electrical resonance may occur due to the distributed capacitance, which may result in damaging the motor insulation or big leakage

current that will make the controller go into protective status.

☆ Grounding terminal must be connected to earth reliably, the grounding cable should be thick and short, the recommended grounding cable should be special yellow-green cable above 4 mm² with several copper cores. And the grounding resistance shall be less than 4Ω. Do not share the earth end and neutral line of the main supply.

2) MCTC-MCB-A main control panel wiring instruction

a) main control panel installation location:

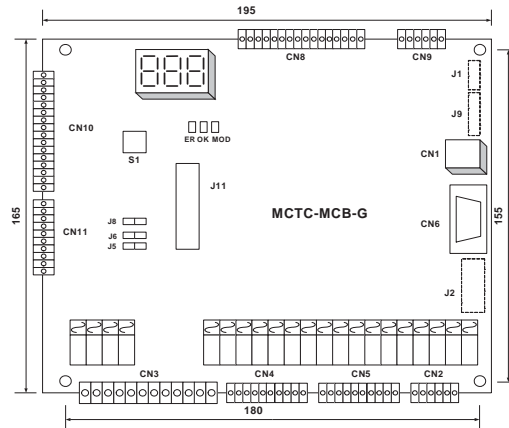

Fig. 3-4

b) indicator light instruction of MCB:

Terminal	Name	Instruction
ER	Error indicator	when error, ER indicator lighten (red)
OK	OK indicator	when no error, OK indicator lighten (green)
MOD	MODBUS communication indicator	when expansion board MODBUS communication well, indicator lighten (green)
X1~X24	Input signal indicator	when external input, indicator lighten (green)
L1~L20	Button signal collective/Feedback indicator	When button input signal connected and responding signal output, indicator lighten (green)

Terminal	Name	Instruction
Y0~Y3, Y6~Y22	Output signal indicator	when signal output, indicator lighten (green)
J5,J6	Communication interface selection jumper	J5, J6 synchronously connect with 232 two feet, selection serial communication function is main control board serial communication; J5, J6 synchronously connect with PRG two feet, selection serial communication function is program download.
J8	Program download jumper	Connected with ON two feet, main control board is in program download model; Connected with OFF two feet, main control board is in normal work model. Note: In normal work state, J8 must be connected with OFF two feet, and J5, J6 must be connected synchronously with 232 two feet.
S1	Well self-tuning button	Keep pressing the button for 3s, the lift shall get into well self-tuning automatically.

c) Main control board terminal list:

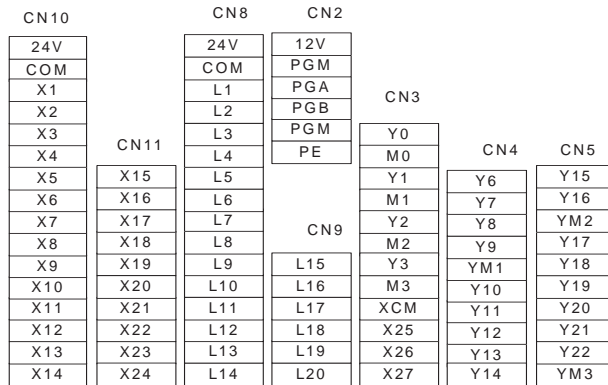
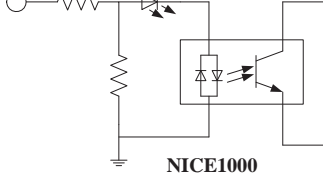

Fig. 3-5

d) Plug-in unit CN10 and CN11 instruction:

Terminal	Name	Terminal description
X1~X24	digital signal input function selection	1.photocoupler isolation input 2.input resistance : 4.7K Ω 3.input voltage range:10~30V 4.input current limit :5mA  NICE1000 Digital terminal function decided by F5-01~F5-24

e) Plug-in unit CN8 and CN10 power instruction:

Terminal	Name	Description
24V	External DC24V input	Provide MCTC-MCB-A main control board and MCTC-KZ-B expansion board with DC24V, for input, output circuit.
COM		

f) lug-in unit CN8 and CN9 output terminal instruction:

Terminal	Name	Description
L1~L20	Button function selection	Button input signal connection and button light outputting, output 24V for button lightening

g) Plug-in unit CN3 output terminal instruction:

Terminal	Name	Description
XCM	External power input	The shared contact by safety circuit and lock feedback circuit, can bear the voltage ranging from AC95V~AC125V

Monarch

Terminal	Name	Description
X25 X26 X27	Safety, lock feedback input	Safety circuit and lock feedback circuit, corresponding function code set by F5-25~F5-27
Y0~Y3	Relay output	The relay outputs 5A, 250VAC or 5A, 30VDC, and corresponding function code is decided by F7-00 ~F7-03.
M0~M3	Relay outputting shared contact	M0, M1, M2, and M3 are the shared contacts separately corresponding to Y0, Y1, Y2, and Y3

h) Plug-in unit CN4 and CN5 output terminal instruction:

Terminal	Name	Description
Y6~Y22	Relay outputting	The relay outputs 5A, 250VAC or 5A, 30VDC, and corresponding function code is decided by F7-06 ~F7-22.
YM1~YM3	Relay outputting shared contact	YM1 is the shared contact by YM6~YM9, YM2 is the shared contact by Y10~Y16, and YM3 is the shared contact by Y17~Y22

i) Plug-in unit CN2 encoder contact terminal instruction:

Terminal	Name	Description
12V	DC12V output	Provide DC15V for encoder, suit for incremental push-pull output or incremental plough collector output.
PGM		
PGA	coding pulse input A phase	Incremental coding pulse signal inputting, frequency dividing signal input A phase and B phase in V motor, PG card.. The system will show the fault of encoder if A phase and B phase are wrongly connected.
PGB	coding pulse input B phase	
PGM	DC12	Power 0V terminal
PE	Grounding terminal	Encoder wire shield layer

CN1 is a panel terminal and CN6 is a master machine monitoring interface

3) MCTC-KZ-B expansion board electric wiring instruction

The expansion board is mainly used for floor input button expansion, relay output expansion, analog weighing expansion and MODBUS communication expansion.

a) Appearance and size of expansion board

The expansion board is equipped on the main control board through J11 contact. Appearance and size are as the following figure:

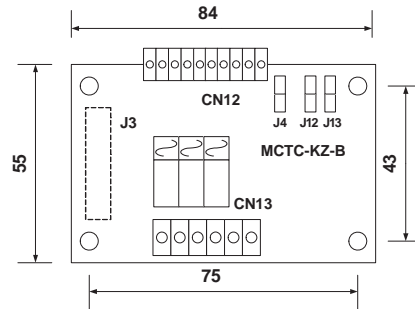

Fig. 3-6 MCTC-KZ-B appearance and size

b) Instruction for the expansion board's indicator and jumper

Terminal	Name	Description
L21~L26	Expansion button signal collective/Feedback indicator	When the input signal of the expansion floor's button is connected, and responding signal outputted, the indicator lighten (green).
Y4~Y5, Y23	Expansion relay output signal indicator	When the system has expansion relay outputting, the indicator lighten (green).
J4	MODBUS communication terminal matching resistance jumper	Connected with ON, MODBUS communication terminal matching resistance is valid; Connected with OFF two feet, MODBUS communication terminal matching resistance is invalidation.
J12, J13	MODBUS communication enables jumper	MODBUS communication is valid when J12, J13 are connected with 485 synchronously. Note: At that moment, all the jumpers of J5, J6 in the main control board must be turned off.

c) Expansion board terminal plug-in unit list:

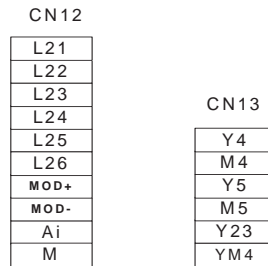

Fig. 3-7 MCTC-KZ-B terminal definition

d) Instruction of expansion board plug-in unit CN12:

Terminal	Name	Description
L21~L26	Expansion button function selection	Expansion button input signal connection and button light outputting, output 24V for button lightening
MOD+, MOD-	MODBUS communication signal wire	Used for expansion MODBUS communication
Ai, M	Expansion analog input	0~10V analog input, M is the shared contact, can be used for analog weighing

e) Instruction of expansion board plug-in unit CN13:

Terminal	Name	Description
Y4~Y5	Relay output	The relay outputs 5A, 250VAC or 5A, 30VDC, and corresponding function code is decided by F7-04 ~F7-05.
M4~M5	Relay output shared contact	M4 is the shared contact of Y4, and M5 is the shared contact of Y5.
Y23	Relay output	The expansion relay outputs 5A, 250VAC or 5A, 30VDC, and corresponding function code is decided by F7-23.
YM4	Relay output shared contact	

4) Encoder wiring

a) Following items should be noticed in encoder wiring:

- PG wire should be laid separately and keep distance from control circuit and driver circuit and forbidden to parallel with them.
 - PG wire should be shield wire, and shield layer should connect to PE near controller. (In order to avoid being disturbed, only one terminal connects to ground.)
 - PG wire should be pulled on pipe separately, and metal crust should be connected to ground reliably.
- b) Instruction of encoder wiring
- Encoder connection of increment push-pull output and plough collector output.

MCTC-MCB-G equipped with push-pull encoder trans-connection card, the encoder connection is as follows:

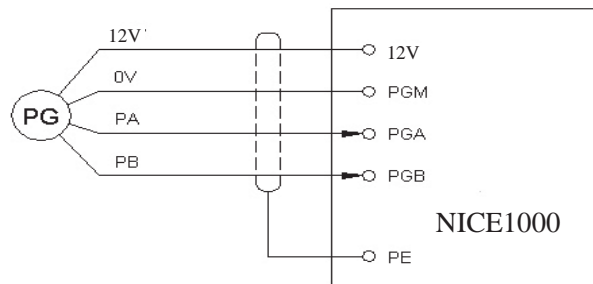

Fig. 3-8 connection of incremental push-pull output and plough collector output encoder

- Type U, V, W and SIN/COS encoder wiring

For NICE 1000, when it uses synchronous motor, SIN/COS is recommended to the users.

For UVW encoder, MCTC-PG-D is assorted with the system.

For SIN/COS encoder, MCTC-PG-E is assorted with the system.

MCTC-PG-D and MCTC-PG-E use DB15 connector and UVW encoder or SIN/COS encoder to connect. The pins' meaning of DB15 connector is listed as follows:

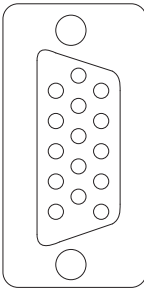
model	Pin's meaning of DB 15	Applicable encoder
MCTC-PG-D	 1: A+ 2: A- 3: B+ 4: B- 5: NC 6: NC 7: U+ 8: U- 9: V+ 10: V- 11: W+ 12: W- 13: VCC 14: COM 15: NC	UVW encoder
MCTC-PG-E	1: B- 2: NC 3: Z+ 4: Z- 5: A+ 6: A- 7: COM 8: B+ 9: VCC 10: C+ 11: C- 12: D+ 13: D- 14: NC 15: NC	SIN/COS encoder

MCTC-PG-D and MCTC-PG-E can be installed on the main control board through the J11 connector on the board. Its size and appearance are as follows:

a) MCTC-PG-D

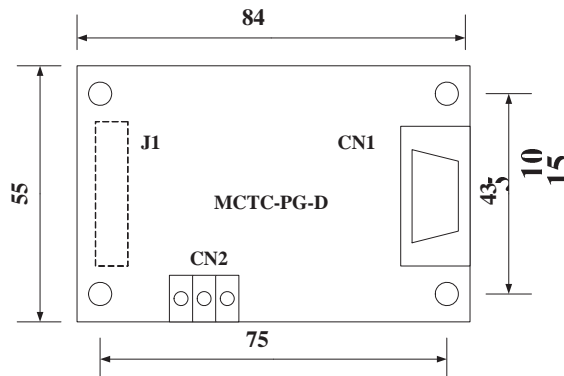

b) MCTC-PG-E

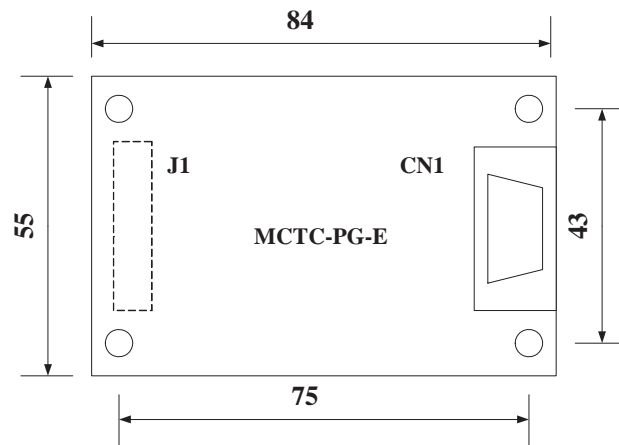

Fig. 3-9 Appearance and size of MCTC-PG-D and MCTC-PG-E
Fig. a), MCTC-PG-D CN2 is the analog inputting terminal.



Instruction of debugging tools

Chapter 4 Instruction of debugging tools

4.1 Debugging tools for NICE 1000

Debugging tools of NICE1000 include three types: operation control and information display panel (operation panel for short), upper monitor motoring software of NICE 1000, and PDA monitoring software. This chapter is focus on the operation panel.

4.2 Operation Panel Description

Through operation panel, user can modify the parameter, monitor the working state, and control running (start and stop) when operation panel is working.

4.2.1 The Appearance and Function Section of Operation Panel

The appearance as Fig. 4-1:

1) Instruction of function indicator lights:

RUN LED on indicates the controller is working.

LOCAL/REMOT Reserved.

FWD/REV Indicator of up and down. LED on indicates the elevator goes down; LED off, up.

TUNE/TC Indicator of tuning. LED on, tuning.

2) Digital display area

5-bit LED display, show the parameters of running speed, bus voltage, etc.

3) Units indicator instruction:

The units' indicator indicates the unit of the figure of the digital display area. When two LEDs are on, it indicates the central unit figure below the 2 LEDs.

Hz:
Frequency unit

A: Current unit
V: Voltage unit



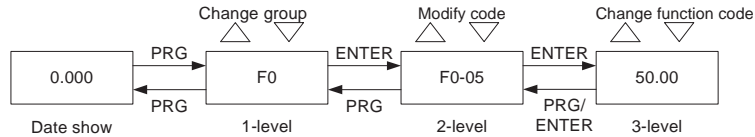

Fig. 4-2 3-level menu operational procedures

Instruction: When in 3rd menu, system can back to 2nd menu by pressing **PRG** or **ENTER**. The difference between the two ways is: it saves parameter after pressing **ENTER**, then back to next function code in 2nd menu; whereas it does not save parameter after pressing **PRG**, then keep staying at the current function code in 2nd menu.

Example: Change function code F0-06 from 50.00Hz to 15.00Hz (bold means flash bit).

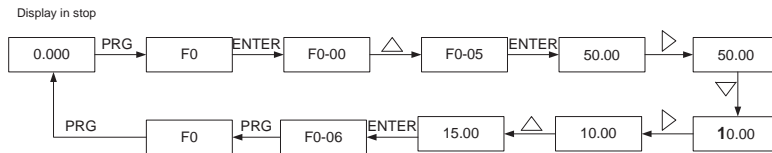

Fig. 4-3 Example for Parameter Change

In the three-level menu, if the parameter has no flash bit, it means the function code cannot be changed and the possible reasons are:

- 1) This parameter of this function code cannot be changed, such as the actually detected parameter and running record parameter.
- 2) This function code cannot be changed in operating status and can only be changed when the controller is stopped.
- 2) To shift the status display parameters by key >>

Example:

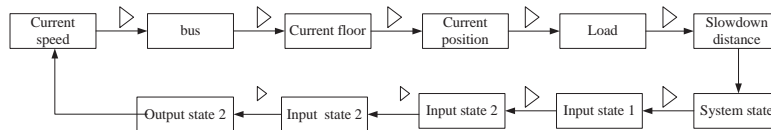

Fig. 4-4 Example of Parameter Changing in Stopping State

In stopping and running status, the LED can display several status

parameters. Whether to display the status parameters depends on the bit setting of FA-01 (running parameter) and FA-02 (stopping parameter). Through key **>>**, user can shift the display in sequence and display the stopping or running status parameters circularly.

In stopping state, there are 12 status parameters for NICE1000, user can shift to display the parameters circularly by key **>>**. The parameters are: rated speed, bus voltage, current floor, current position, car load, rated decelerate distance, system state, input terminal 1 state, input terminal2 state, input terminal3 state, output terminal 1 state, output terminal 2 state. Users can select the desired parameters through the bit of FA-02.

In running state, there are 16 state parameters for NICE1000. Users can shift to display the parameters circularly by key **>>**. The parameters are: running speed, rated speed, bus voltage, output voltage, output current, output frequency, current floor, current position, car load, system state, pre-torque current, input terminal 1 state, input terminal 2 state, input terminal 3 state, output terminal 1 state, output terminal 2 state. Users can select the desired parameters through the bit of FA-01.

3) Error information reading

When error occurs in the controller, the error information will be displayed on the panel. It is convenient to find reasons for the error and rule out the error as soon as possible.

The controller can save the last 6 error codes. Users can read the first error code in the following way:

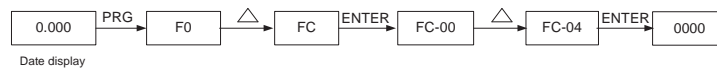

Fig. 4-5 Method of viewing error information

4.2.3 Password Setting

In order to protect the parameter more effectively, the controller provides the password protection.

The figures below show how to change the password to 12345 (bold shows flashing bit):

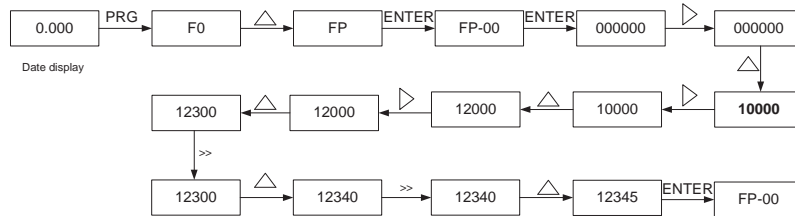

Fig. 4-9 Password setting procedure

When the user has set the password (the password parameter of FP-00 shouldn't be ZERO), the password protection function is valid once the user presses PRG, and the controller shall display "-----". The user can enter the menu only after inputting the user password. For factory setting parameters editing, the user still need to input the factory password. (Warning: do not change the factory setting parameter; if the parameter values are wrong, the controller will work abnormally, even be damaged.)

When the password protection is unlocked, user can change the password freely, and the last input number will be the user password.

If the user wants to cancel the password protection function, enter after inputting the password and set FP-00 as 0; when the power is on, the parameter will be protected by the password if FP-00 isn't set ZERO.



Function parameters

Chapter 5 Function parameters table

5.1 Description of function parameters

1. Function parameters are classified into 17 groups. Each group has several function codes. The function code uses 3-level menu with the format "F X-XX", which means "No. XX function code in group X". For example, F 8-08 means the No.8 function code in group F8.

In order to make functional code setting convenient, the function group number corresponds to first level menu, the function code number corresponds to second level menu, and function code parameters correspond to third level menu.

2. Contents in the function table:

Column 1 "function code", means the serial number for function parameter group and parameter;

Column 2 "name", means the complete name of the function parameter;

Column 3 "setting range", means the parameter setting range;

Column 4 "minimum unit", means the minimum unit of the parameter setting;

Column 5 "factory setting", means the original default;

Column 6 "operation", means the modification attributes of the parameters (whether to enable the modification and the modification requirements).

Instructions are listed below:

☆: the parameter can be modified while the NICE1000 is running or stopping;

★: the parameter can not be modified while the NICE1000 is running;

* : the parameter cannot be modified for it is actually measured and recorded.

3. "Factory Default" means the numeric value after the function code parameter is refreshed when recovering the default parameter, but the actually measured value or recorded value will not be refreshed.

4. The controller provides password protection of function code to protect

the parameters effectively (details in Chapter 4.2.3).

5.2 Function parameter table

5.2.1 Groups of function parameters

Press PRG buttons and then UP/DOWN button, all of the displays are first level menu, which are group of function. Details as follows:

- F0——Basic parameter
- F1——motor parameter
- F2——vector control parameter
- F3——running control parameter
- F4——floor parameter
- F5——terminal input parameter
- F6——elevator basic parameter
- F7——terminal output parameter
- F8——buildup function parameter
- F9——time parameters
- FA——keyboard setting parameter
- FB——door function parameter
- FF——factory parameter
- FP——user parameter

5.2.2 Function parameter table

Code	Name	Setting range	Min. unit	Factory default value	Operation
F0 Basic parameter					
F0-00	Control mode	0:open-loop vector 1:close-loop vector	1	1	★
F0-01	Command source selection	0 :operating panel control 1 :space control	1	1	★
F0-02	Running speed of panel control	0.050~F0-04	0.001m/s	00.050m/s	☆
F0-03	Max. speed of elevator	0.200~F0-04	0.001m/s	0.480m/s	★

Code	Name	Setting range	Min. unit	Factory default value	Operation
F0-04	Rated speed of elevator	0.200~1.000m/s	0.001m/s	0.500m/s	★
F0-05	Max. frequency	10.00Hz~99.00Hz	0.01Hz	50.00Hz	★
F0-06	Carrier frequency	0.5~16.0kHz	0.01kHz	6.0kHz	☆
F1 Motor parameter					
F1-00	Encoder type selection	0:SIN/COS increment 1:UVW increment 2:push-pull	1	2(asynchronous) 1(synchronous)	★
F1-01	Rated power	2.2~75.0kW	0.1kW	model dependent	★
F1-02	Rated voltage	0~440V	1V	380V	★
F1-03	Rated current	0.00~655.00A	0.01A	Model dependent	★
F1-04	Rated frequency	0.00~99.00Hz	0.01Hz	50.00Hz	★
F1-05	Rated rotate speed	0~3000rpm	1 rpm	1460rpm	★
F1-06	Stator resistance (asynchronous) Initial rotation speed (synchronous)	0.000~30.000Ω 0.0~359.9	0.001Ω 0.1	Model dependent	☆
F1-07	Rotor resistance	0.000~30.000Ω	0.001Ω	Model dependent	☆

Code	Name	Setting range	Min. unit	Factory default value	Operation
F1-08	Leakage inductance (asynchronous)	0.01~300.00mH	0.01mH	Model dependent	☆
	Wiring mode (synchronous)	0~15	1		
F1-09	Mutual inductance(asynchronous)	0.1~3000.0mH	0.1mH	Model dependent	☆
	Reserved(synchronous)				
F1-10	No-load current	0.01~300.00A	0.01A	Model dependent	☆
F1-11	Tuning selection	0 :no operation 1:static tuning (asynchronous) Initial angle tuning (synchronous) 2.no initial angle tuning(synchronous)	1	0	★
F1-12	Pulse number per round of coder	0~10000	1	1024	★
F1-13	Fault detection time of encoder	0~10.0s (if <1s, invalid)	0.1	2.1	★
F2 Vector control parameters					
F2-00	Proportional gain1 of speed loop	0~100	1	40	☆

Code	Name	Setting range	Min. unit	Factory default value	Operation
F2-01	Integration time 1 of speed loop	0.01~10.00s	0.01s	0.60s	☆
F2-02	Switching frequency 1	0.00~F2-05	0.01Hz	2.00Hz	☆
F2-03	Proportional gain 2 of speed loop	0~100	1	35	☆
F2-04	Integration time 2 of speed loop	0.01~10.00s	0.01s	0.80s	☆
F2-05	Switching frequency 2	F2-02~F0-05	0.01Hz	5.00Hz	☆
F2-06	Proportional gain1 of current loop	10~500%	1%	60%	☆
F2-07	Integration time 1 of current loop	10~500%	0.1%	30%	☆
F2-08	Upper limit of torque filter	0.0~200.0%	0.1%	150.0%	☆
F2-09	Reserved				☆
F2-10	Running direction of elevator	0:The same direction 1:reversed direction: 2 The same direction 3.reversed	1	0	☆
F3 Running control parameter					
F3-00	Startup speed	0.000~0.030m/s	0.001m/s	0.000m/s	★
F3-01	Holding time of startup time	0.000~0.500s	0.001s	0.000s	★

Code	Name	Setting range	Min. unit	Factory default value	Operation
F3-02	Acceleration	0.200~0.800m/s ²	0.001m/s ²	0.300m/s ²	★
F3-03	Inflexion acceleration time 1	0.300~4.000s	0.001s	2.500s	★
F3-04	Inflexion acceleration time 2	0.300~4.000s	0.001s	2.500s	★
F3-05	Deceleration	0.200~0.800m/s ²	0.001m/s ²	0.300m/s ²	★
F3-06	Inflexion deceleration time 1	0.300~4.000s	0.001s	2.500s	★
F3-07	Inflexion deceleration time 2	0.300~4.000s	0.001s	2.500s	★
F3-08	Special deceleration	0.500~2.000m/s ²	0.001m/s ²	0.500m/s ²	★
F3-09	Stop distance allowance	0~90.0mm	0.1mm	0.0mm	★
F3-10	Re-leveling speed	0.000~0.800m/s	0.001m/s	0.040m/s	★
F3-11	Speed of slow running	0.100~0.500m/s ²	0.001m/s	0.250m/s	★
F3-12	Switch position of up force reducer	0.000m~300.00m	0.01m	0.00m	★
F3-13	Switch position of up force reducer	0.000m~300.00m	0.01m	0.00m	★
F3-14	Output time of starting zero speed	0.000~1.000s	0.001s	0.200s	★
F3-15	Delayed-time of	0.000~1.000s	0.001s	0.200s	★

Code	Name	Setting range	Min. unit	Factory default value	Operation
	curve running				
F3-16	Delayed-time of stop running	0.000~1.000s	0.001s	0.300s	★
F4 Floor parameters					
F4-00	Leveling adjusting	0~60mm	1	30mm	★
F4-01	Current floor	Lowest(F6-01)~highest(F6-00)	1	1	★
F4-02	High bit of current floor	0~65535	1	1	*
F4-03	Low bit of current floor	0~65535	1	34464	*
F4-04	Length of flashboard1	0~65535	1	0	★
F4-05	Length of flashboard2	0~65535	1	0	★
F4-06	High bit of Floor 1	0~65535	1	0	★
F4-07	Low bit of Floor 1	0~65535	1	0	★

Code	Name	Setting range	Min. unit	Factory default value	Operation
F4-08	High bit of Floor 2	0~65535	1	0	★
F4-09	Low bit of Floor 2	0~65535	1	0	★
F4-10	High bit of Floor 3	0~65535	1	0	★
F4-11	Low bit of Floor 3	0~65535	1	0	★
F4-12	High bit of Floor 4	0~65535	1	0	★
F4-13	Low bit of Floor 4	0~65535	1	0	★
F4-14	High bit of Floor 5	0~65535	1	0	★
F4-15	Low bit of Floor 5	0~65535	1	0	★
F4-16	High bit of Floor 6	0~65535	1	0	★

Code	Name	Setting range	Min. unit	Factory default value	Operation
F4-17	Low bit of Floor 6	0~65535	1	0	★
F4-18	High bit of Floor 7	0~65535	1	0	★
F4-19	Low bit of Floor 7	0~65535	1	0	★
F4-20	High bit of Floor 8	0~65535	1	0	★
F4-21	Low bit of Floor 8	0~65535	1	0	★
F4-22	High bit of Floor 9	0~65535	1	0	☆
F4-23	Low bit of Floor 9	0~65535	1	0	☆
F4-24	Low bit of 10 floor	0~65535	1	0	★
F4-25	Low bit of 10 floor	0~65535	1	0	★
F4-26	Reserved	0~65535	1	0	*
F5 Terminal Function parameters					

Code	Name	Setting range	Min. unit	Factory default value	Operation
F5-00	Attendant automatic switch	3~200	1	3	★
F5-01	Function selection of X1	1~99(N.O.), 101~199(N.C.)	1	03	★
F5-02	Function selection of X2	00: unused 01:leveling 1 signal	1	104	★
F5-03	Function selection of X3	02: leveling 2 signal 03:area signal	1	105	★
F5-04	Function selection of X4	04:running output feedback signal	1	109	★
F5-05	Function selection of X5	05:brake output feedback 1 signal	1	10	★
F5-06	Function selection of X6	06:brake output feedback 2 signal	1	11	★
F5-07	Function selection of X7	07:self-locking feedback signal	1	12	★
F5-08	Function selection of X8	08:door lock jump-out output feedback signal	1	14	★
F5-09	Function selection of X9	09:examine signal 10:examine up signal 11:examine down signal 12:once fire information 13:reserved 14:lock step signal	1	115	★

Code	Name	Setting range	Min. unit	Factory default value	Operation
F5-10	Function selection of X10		1	116	★
F5-11	Function selection of X11		1	117	★
F5-12	Function selection of X12		1	118	★
F5-13	Function selection of X 13		1	119	★
F5-14	Function selection of X 14		1	22	★
F5-15	Function selection of X 15		1	126	★
F5-16	Function selection of X16		1	28	★
F5-17	Function selection of X17		0.1%	30	☆
F5-18	Function selection of X18		0.01	124	☆

Code	Name	Setting range	Min. unit	Factory default value	Operation
F5-19	Function selection of X19		1	00	★
F5-20	Function selection of X20		1	00	★
F5-21	Function selection of X21		1	00	★
F5-22	Function selection of X22		1	00	★
F5-23	Function selection of X23		1	00	★ ★
F5-24	Function selection of X24		1	00	★
F5-25	Strong power input function selection of X25		1~99	1	01
F5-26	Strong power input function selection of X26	00:unused 01:security circuit signal 02:door circuit1 signal	1	02	★
F5-27	Strong power input function selection of X27	03:door circuit2 signal 04~99:reserved	1	03	★

Code	Name	Setting range	Min. unit	Factory default value	Operation
F5-28	State display 1 of input/output terminal	-	-	-	*
F5-29	State display of input/output terminal	-	-	-	*
F5-30	State display1 of floor input/output terminal	-	-	-	*
F5-31	State display2 of floor input/output terminal	-	-	-	*
F6 Elevator basic parameters					
F6-00	Highest floor	Lowest floor (F6-01)~10	1	5	★
F6-01	Lowest floor	1~highest floor(F6-00)	1	1	★
F6-02	Parking main landing	Lowest floor (F6-01) ~ Highest floor(F6-00)	1	1	★
F6-03	Fire main landing	Lowest floor (F6-01) ~ Highest floor(F6-00)	1	1	★
F6-04	Lift lock main landing	Lowest floor (F6-01) ~ Highest floor(F6-00)	1	1	★
F6-05	Service floor	0~1023	1	1023	★
F6-06	Reserved				☆

Code	Name	Setting range	Min. unit	Factory default value	Operation
F6-07	Group control number	1~2	1	1	★
F6-08	Elevator number	1~2	1	1	★
F6-09	Random examine times	0~6000	1	0	☆
F6-10	Enabled detection selection	Bit0:external-call enable Bit1:open door	1	0	☆
F6-11	L1 function selection	00:unused 201~203(door1 on-off door)	1	201	★
F6-12	L2 function selection	204~209(reserved) 210~219(door1 internal call)	1	202	★
F6-13	L3 function selection	220~229(door1 up external call) 230~239(door1 down external call)	1	203	★
F6-14	L4 function selection	240~299(reserved)	1	00	★
F6-15	L5 function selection	301~399(door 2) 201:open button of door 1	1	211	★
F6-16	L6 function selection	202:close button of door 1	1	212	★

Code	Name	Setting range	Min. unit	Factory default value	Operation
F6-17	L7 function selection		1	213	★
F6-18	L8 function selection		1	214	★
F6-19	L9 function selection		1	215	★
F6-20	L10 function selection		1	00	★
F6-21	L11 function selection		1	00	★
F6-22	L12 function selection		1	00	★
F6-23	L13 function selection		1	221	★
F6-24	L14 function selection		1	222	★

Code	Name	Setting range	Min. unit	Factory default value	Operation
F6-25	L15 function selection		1	223	★
F6-26	L16 function selection		1	224	★
F6-27	L17 function selection		1	232	★
F6-28	L18 function selection		1	233	★
F6-29	L19 function selection		1	234	★
F6-30	L20 function selection		1	235	★
F6-31	L21 function selection		1	00	★
F6-32	L22 function selection		1	00	★

Code	Name	Setting range	Min. unit	Factory default value	Operation
F6-33	L23 function selection		1	00	★
F6-34	L24 function selection		1	00	★
F6-35	L25function selection		1	00	★
F6-36	L26 function selection		1	00	★
F7 Terminal output function parameters					
F7-00	Y0 function selection	00~99 00:unused 01~31: F7-01~F7-23 32:electricity off, emergency running valid 33~99:reserved	1	00	★
F7-01	Y1 function selection	01~05 00:unused 01:running	1	01	★

Code	Name	Setting range	Min. unit	Factory default value	Operation
F7-02	Y2 function selection	contactor output 02:brake contactor output	1	02	★
F7-03	Y3 function selection	03:brake forced output 04:illumination and fan output 05:synchronous motor self-locking output	1	04	★
F7-04	Y4 function selection	06~31 00:unused	1	00	★
F7-05	Y5 function selection	06:door1 open output	1	00	★
F7-06	Y6 function selection	07:door1 close output 08:door2 open output	1	06	★
F7-07	Y7 function selection	09:door2 close output	1	07	★
F7-08	Y8 function selection	10:low 7 segment code a display output	1	08	★
F7-09	Y9 function selection	11:low 7 segment b display output	1	09	★
F7-10	Y10 function selection	12: low 7	1	10	★

Code	Name	Setting range	Min. unit	Factory default value	Operation
F7-11	Y11 function selection		1	11	★
F7-12	Y12 function selection		1	12	★
F7-13	Y13 function selection		1	13	★
F7-14	Y14 function selection		1	00	★
F7-15	Y15function selection		1	00	★
F7-16	Y16 function selection		1	25	★
F7-17	Y17 function selection		1	17	★
F7-18	Y18 function selection		1	18	★
F7-19	Y19 function selection		1	19	★
F7-20	Y20 function selection		1	20	★
F7-21	Y21 function selection		1	21	★

Code	Name	Setting range	Min. unit	Factory default value	Operation
F7-22	Y22 function selection		1	22	★
F7-23	Y23 function selection		1	00	★
F7-24	Reserved				☆
F8 Enhance function parameters					
F8-00	weighing self-tuning setting	0~100%	1%	0%	★
F8-01	Pre-torque selection	0:pre-torque invalid 1:pre-torque valid 2:automatic calculate pre-torque	1	0	★
F8-02	Pre-torque excursion, Zero servo current coefficient	0.0%~100.0% 0.20~50.0	0.1%	50.0%	★
F8-03	Drive side bias, Zero servo speed loop KP	0.00~2.00	0.01	0.60	★
F8-04	Braking side bias, Zero servo speed loop TI	0.00~2.00	0.01	0.60	★
F8-05	Reserved				☆
F8-06	Car no-load setting	0~1023	1	0	★
F8-07	Car full-load	0~1023	1	100	★

Code	Name	Setting range	Min. unit	Factory default value	Operation
	setting				
F8-08	Load weighing input selection	0:invalid 1:reserved 2:analogue sampling	1	0	★
F8-09	Power off emergency save speed	0.000~0.100m/s	0.001m/s	0.05m/s	★
F8-10	Power off emergency save selection	0: no running of motor 1:UPS supply running 2:48V accumulator supply	1	0	★
F8-11	Delayed-time of stop torque output	0.200~1.500s	0.001s	0.200s	★
F9 Time parameters					
F9-00	Time of free back to main landing	0 :invalid; 1~240	1min	10min	☆
F9-01	Fan(illumination) off time	0:invalid, which means fan is running all the time; 1~240min	1min	12min	☆
F9-02	Max. interval of floor running	0~45s Invalid if less than 3s	1	45	★
F9-03	Accumulative runtime	0~65535h	1	0	*
F9-04	Reserved				☆
F9-05	High bit o running times	0~9999 Note:1= 10000 actual	1	0	*

Code	Name	Setting range	Min. unit	Factory default value	Operation
		running times			
F9-06	Low bit of running times	0~9999	1	0	*
FA Keyboard setting parameters					
FA-00	Baud rate setting	0~5:9600BPS 6:19200BPS 7:38400BPS	1	5	★

Code	Name	Setting range	Min. unit	Factory default value	Operation
FA-01	Running display	1-65535 Bit0:running speed Bit1:rated speed Bit2:bus voltage Bit3:output voltage Bit4:output current Bit5:output frequency Bit6:current floor Bit7:current position Bit8:car load Bit9:system state Bit10:pre-torque current (%) Bit11: state of input terminal 1 Bit12: state of input terminal 2 Bit13: state of input terminal 3 Bit14: state of output terminal 1 Bit15:state of output terminal 2	1	65535	☆
FA-02	Stop display	1-65535 Bit0:rated speed	1	65535	☆

Code	Name	Setting range	Min. unit	Factory default value	Operation
		Bit1:bus current Bit2:current floor Bit3:current position Bit4:car load Bit5:rated step decelerate distance Bit6:system state Bit7: state of input terminal1 Bit8: state of input terminal2 Bit9: state of input terminal3 Bit10: state of output terminal 1 Bit11:state of output terminal 2			
FA-03	Current angle of pulse wheel encoder	0.0~360.0	0.1	0.0	*
FA-04	Software edition (ZK)2	0~65535	1	0	*
FA-05	Software edition (DSP) 3	0~65535	1	0	*
FA-06	Radiator temperature	0~100℃	1℃	0	*
FB Door function parameter					

Code	Name	Setting range	Min. unit	Factory default value	Operation
FB-00	Door machine number	1~2	1	1	★
FB-01	Opposite door option	0~3	1	0	★
FB-02	Door machine 1 service floor	0~1023(set1~10, 1: normal open door; 0:forbid to open the door)	1	1023	☆
FB-03	Manually operating open in right position delay time	1~60s	1	5	☆
FB-04	Door machine 2 service floor	0~1023(set1~10, 1: normal open door; 0:forbid to open the door) Only valid when door machine number is 2.	1	1023	☆
FB-05	Back floor parking delay	0.00~2.00s	0.00	0.00	☆
FB-06	Open door time protection	5~99s After the protection, the elevator will berth at the nearest floor and report open door fault.	1s	10s	☆
FB-07	Program control option	Bit 0:reserved Bit1:reserved Bit2: reserved	1	0	☆

Code	Name	Setting range	Min. unit	Factory default value	Operation
		Bit3: reserved Bit4: slash valid when stop for 300MS current Bit5: reserved Bit6 reserved Bit7 reserved Bit8 no output when close the door in place, only judge door-locked loop 1. Bit 9 reserved Bit10 delay 1 second and no output when close the door in place(no judgment for door-locked loop) Bit11 delay for 1s and no output when open door in place Bit12 reserved Bit13 high/low voltage signal test for 1.5s			
FB-08	Close door time protection	5~99s After the protection, the elevator will close the door again and report close door fault.	1s	15s	☆

Code	Name	Setting range	Min. unit	Factory default value	Operation
FB-09	Open/close times	0~20 0:invalid After trial open/close times, the elevator will stop running, and report the fault.	1	0	☆
FB-10	State of parking main landing door	0:normal open door 1:wait to open door 2 door open in every floor	1	0	☆
FB-11	Door holding time 1 (external call)	1-120s	1s	5s	☆
FB-12	Door holding time 2 (internal call)	1~120s	1s	3s	☆
FB-13	Door holding time 3 (delayed time)	10~1000s	1s	30s	☆
FC Protection function parameter					
FC-00	Power on grounding short test selection	0:forbid 1:permit	1	1	★
FC-01	Over-load protection selection	Bit0:over-load protection selection 0: Enabled	1	1	☆

Code	Name	Setting range	Min. unit	Factory default value	Operation
		1: Disabled Bit1:output phase failure selection 0:phase failure protection 1:phase failure no-protection Bit2:over-modulate function selection 0:valid 1:invalid			
FC-02	Over-load protection coefficient	0.50~10.00	0.01	1.00	☆
FC-03	Over-load precaution coefficient	50~100%	1%	80%	☆
FC-04	The first error information	0~3199 Note: The first two figures mean the floor's number, and the last two mean the error code. e.g. error 30 occurs in Floor1(the elevator's position is abnormal), the error information displays 0130. 0: No error	1	0	*

Code	Name	Setting range	Min. unit	Factory default value	Operation
		1: Inverse unit protection			
		2:Over current accelerated			
		3:Over current decelerated			
		4: Over current constant			
		5:Over voltage accelerated			
		6:Over voltage decelerated			
		7: Over voltage constant			
		8: Controller power fault			
		9: Under voltage fault			
		10: System overload			
		11: Motor overload			
		12: Input side phase failure			
		13: Output side phase failure			
		14: Module overheated			
		15: Reserved			
		16: Reserved			

Code	Name	Setting range	Min. unit	Factory default value	Operation
		17: Contactor fault 18: Current detection fault 19: Motor tuning fault 20: rotary coder fault 21: Synchronous motor encoder wiring error 22: Leveling inductor signal is abnormal 23: Short circuit fault to ground 24: Door lock2 abnormal 25: Data storage error 26~28: Reserved 29: Synchronous self-locking contactor feedback is deviant 30: Lift position is deviant 31: Reserved 32: Reserved 33: Lift over speed error 34: Logic fault 35: Well self-tuning			

Code	Name	Setting range	Min. unit	Factory default value	Operation
		date is deviant 36:Contact feedback is deviant 37:Brake feedback is deviant 38:Controller encode signal is deviant 39: Reserved 40: Lift running condition is not satisfied 41: Safety circuit cut 42:Door lock cut when running 43:Upper limit signal cut when running 44:Lower limit signal cut when running 45: Up/Down force reducer switch cut 46: Re-leveling is deviant 47:Lock contactor is deviant 48: Door open fault 49: Door close fault 50:Reserved			

Code	Name	Setting range	Min. unit	Factory default value	Operation
		51: Reserved 52: Reserved 53: Lock jump out fault			
FC-05	The second error information	0~3199	1	0	*
FC-06	The third error information	0~3199	1	0	*
FC-07	The fourth error information	0~3199	1	0	*
FC-08	The fifth error information	0~3199	1	0	*
FC-09	The latest error information	0~3199	1	0	*
FC-10	The latest error speed	0.000~3.000m/s	0.001m/s	0.000m/s	*
FC-11	The latest error current	0.0~999.0A	0.1A	0.0A	*
FC-12	The latest error bus voltage	0~999V	0~999V	1V	*
FD Reserved parameter					
FD-00	Reserved		1	0	☆
FE Elevator function setting					
FE-00	Selective mode	0:Full selective 1:Down selective 2:Up selective	1	0	☆

Code	Name	Setting range	Min. unit	Factory default value	Operation
FE-01	Respective display of floor 1	0000~1999 Note: the first two numbers represent tens digit code of the floor; the last two represent first rank code. The first rank codes are as follows: 00:display“0” 01:display“1” 02:display“2” 03:display“3” 04:display“4” 05:display“5” 06:display“6” 07:display“7” 08:display“8” 09:display“9” 10~17:no display 18:display “_” , or bigger 19: no display	1	1901	☆
FE-02	Respective display of floor 2		1	1902	☆
FE-03	Respective display of floor 3		1	1903	☆
FE-04	Respective display of floor 4		1	1904	☆
FE-05	Respective display of floor 5		1	1905	☆
FE-06	Respective display of floor 6		1	1906	☆
FE-07	Respective display of floor 7		1	1907	☆
FE-08	Respective display of floor 8		1	1908	☆
FE-09	Respective display of floor 9		1	1909	☆
FE-10	Respective display of floor 10		1	0100	☆
FE-11	Reserved				☆

Code	Name	Setting range	Min. unit	Factory default value	Operation
FE-12	External call output selection	0:7 segment code 1:BCD code 2:reserved 3: binary code	1	1	★
FE-13	Factory function setting selection	0~65535 Select according to bit; if this bit is 1, the function is valid. Bit0:reserved Bit1: no attendant responding to hall call Bit2:re-leveling Bit3:reserved Bit4:reserved Bit5: reserved Bit6:inspection open the door by non-door area button Bit7:inspection turn normal open the door once Bi8:manually operate the opposite door in inspection/attendant state Bit9:self running Bit10: examine	1	33795	★

Code	Name	Setting range	Min. unit	Factory default value	Operation
		automatic close door Bit11:door open for inside call Bit12:reserved Bit13:emergency automatic slide function Bit14:emergency self-save overtime protection Bit15:door lock short wiring examine function			
FE-14	Factory function setting selection	0~65535 Select according to bit; if this bit is 1, the function is valid. Bit0:reserved Bit1:open door to the right position, keep open Bit2:no close door during running Bit3: manually operate door function selection Bit4: reset of contact conglutination automatic	1	2080	★

Code	Name	Setting range	Min. unit	Factory default value	Operation
		Bit5:forced decelerate switch conglutination test Bit6:open the door delay time button continue to open the door Bit7:reserved Bit8:delay the close of brake when no order after running Bit9: immediate stop when opposite leveling Bit10:U,V,W jump contactor normally open output Bit11:no close door command after light off Bit12:lighting and fans normally closed output Bit13:fire back to base .no output when lift run normally Bit14:keep opening time extension when no call Bit15:reserved			
FF	Factory default parameter(reserved)				

Code	Name	Setting range	Min. unit	Factory default value	Operation
FP User parameter					
FP-00	User password	0-65535 0:no password	1	0	☆
FP-01	Parameter update	0:none 1:restore to factory default value 2:clear memory information	1	0	★



Functional parameter Specification

Chapter 6 Functional parameter Specification

6.1 Group F0 Basic Function Group

F0-00	Control mode	Factory default value	1	Min. Unit	1
	Setting Range	0,1			

Select the control mode of the system.

0: Open-loop vector. No speed sensor vector control. It is mainly applicable for low speed running in adjusting and fault judging in maintaining of asynchronous motor.

1: Closed-loop vector. Vector control with speed sensor. It's used for distance control in normal running.

NOTE: The synchronous motor can not run with open- loop. Please do motor tuning before lift inspection running.

F0-01	Command source selection	Factory default value	1	Min. Unit	1
	Setting Range	0, 1			

It can set the lift running type with travel mode and speed command.

0: Operating panel command channel. Command control by pressing **RUN**, **STOP**. The running speed is decided by parameter F0-02(Panel controller running speed).

1: Distance control. It is used for NICE1000. It enables direct parking according to the distances from the current floor to the target floor while calculating running speed and curves automatically.

F0-02	Operating panel speed	Factory default value	0.050 m/s	Min. Unit	0.001m/s
	Setting Range	0.050~F0-04			

This function can only be used when function code is F0-01=0(operating panel command channel).

It sets the default of speed when lift is used by operating panel. You can modify this code to change speed of operating panel control

when traveling.

F0-03	Lift Max. running speed	Factory default value	0.480m/s	Min. Unit	0.001m/s
	Setting Range	0.200~F0-04			

It can set the Max. running speed and it must below rated speed of the lift.

F0-04	Lift rated speed	Factory default value	0.500 m/s	Min. Unit	0.001m/s
	Setting Range	0.200~1.000m/s			

It means rated speed of nameplate of lift. This function parameter is decided by the machine and motor of the lift. The parameter F0-03 means the actual speed within the speed range of F0-04.

For example: One lift rated speed is 0.500m/s, but the actual maximum speed is 0.480 m/s. So F0-03 = 0.480 m/s; F0-04 = 0.500 m/s.

F0-05	Max. frequency	Factory default value	50.00Hz	Min. Unit	0.01Hz
	Setting Range	10.00~99.00Hz			

It can set Max. Frequency of system output and the frequency must be higher than rated frequency of the motor.

F0-06	Carrier frequency	Factory default value	6.0kHz	Min. Unit	0.1kHz
	Setting Range	0.5~16.0kHz			

The magnitude of carry frequency is closely related to the noise of motor running. The carry frequency is generally set upward 6 KHz to manage to travel without noise. To the best of noise allowing range, reduce the carry frequency

When the carrier frequency is low, the output current higher-harmonic component increases, the consumption and

temperature rise of the motor increase as well.

When the carrier frequency is high, the motor consumption declines and the motor temperature rise reduces, but the consumption, temperature rise and interference of the system increase.

To regulate the carrier frequency will exert influences on the following performances:

Carrier Frequency	Low	~	High
Motor noise	Large	~	Small
Output Current Wave Form	Poor	~	Good
Motor Temperature Rise	High	~	Low
System Temperature Rise	Low	~	High
Leakage Current	Small	~	Large
External Radiation Interference	Small	~	Large

6.2 F1 Group Motor Parameters

Function code	Name	Factory default value	Min. Unit	Setting Range
F1-00	Encoder type selection	2(Asynchronous motor) 1(Synchronous motor)	1	0: SIN/COS 1: UVW 2: Push-pull
F1-01	Rated power	Depending on the model	0.1kW	1.1~75.0kW
F1-02	Rated voltage	380V	1V	0~440V
F1-03	Rated current	Depending on the model	0.01A	0.00~655.00A
F1-04	Rated frequency	50.00Hz	0.01Hz	0.00~99.00Hz
F1-05	Rated rotation speed	1460rpm	1rpm	0~3000rpm

Please set according to the nameplate parameters of the motor.

The accurate motor parameters can ensure the excellent control performance of the vector. The system enables the parameters the automatic identification function. The accurate parameter identification is based on the correct setting of the motor rated parameters.

Function code	Name	Factory default value	Min. Unit	Setting Range
F1-06	Stator resistance (Asynchronous motor)	Model dependent	0.001Ω	0.000~30.000Ω
	Initialized angle (Synchronous motor)	Model dependent	0.1°	0~359.9°
F1-07	Rotor resistance (asynchronous)	Model dependent	0.001Ω	0.000~30.000Ω 0~359.9
	Current coder angle before power off (synchronous)		0.00	
F1-08	Leakage inductance (Asynchronous motor)	Model dependent	0.01mH	0.00~300.00mH
	Wiring connection (Synchronous motor)	Model dependent	1	0~15
F1-09	Mutual inductance (asynchronous) Reserved (synchronous)	Model dependent	0.1mH	0.1~3000.0mH
F1-10	No-load current(asynchronous)	Model dependent	0.01A	0.01~300.00A
	Coder angle check (synchronous)	02	00	00~02

To ensure system performance, please set according to the system standard of the motor arrangement. If the motor power is very different from the standard motor power, the performance of system control may decline.

The parameter F1-06 stands for different meanings when applied to different motors. When it's used in asynchronous motor, it means the stator resistance. When it's used in synchronous motor, it means the encoder initialized angle. No matter which motor to be used in, this parameter can be created after NICE1000 tuning. And users can modify this parameter according to actual condition.

If the automatic tuning of the motor is completed normally, the setup values in F1-F6 to F1-F10 will update automatically.

When NICE1000 is used for asynchronous motor: the system can gain these parameters through complete tuning or static tuning. If the motor

cannot be tuned on the spot, the known parameters of the same kind of motors can be a reference for manual input. After modifying the asynchronous motor's rated power F1-01, the parameter values in F1-06 to F1-10 will automatically recover to the default standard motor parameters.

When NICE1000 is used for permanent-magnet synchronous motor: the system can gain parameters F1-06, F1-08 through initial angle tuning. After modifying the rated power F1-01, the parameter values in F1-06 to F1-10 will not automatically recover.

F1-11	Tuning selection	Factory default value	0	Min. Unit	1
	Setting Range	0, 1 ,2			

Note: The correct motor rated parameters (F1-01~F1-05) must be set before tuning.

0: No tuning.

1: Static tuning (Asynchronous motor)

Loaded Initial angle tuning (Synchronous motor)

2:Non-load initial angle tuning (synchronous motor)

Note: If using the permanent-magnet synchronous motor, It is forbidden that travel the permanent-magnet synchronous motor before complete the initial angle tuning.

- Automatically tuning step of asynchronous motor is following:
 - 1) First, set F0-01 to 0: the control mode is selected to the operating panel control;
 - 2) Set F1-01,F1-02,F1-03,F1-04,F1-05 according to the nameplate of motor, and set F1- 00,F1-F2 according to the coder nameplate
 - 3) F1-11 selects 1(static tuning).Then press **RUN** of the operating panel and the motor can automatically run. The control automatically counts three parameters as follows: F1-06 (stator resistance), F1-07 (rotor resistance), and F1-08 (leakage inductance). It automatically counts the motor's F1-09 (mutual inductance), F1-10 (no-load excitation current). The motor tuning is

then over.

- Automatically tuning step of permanent-magnet synchronous non-load motor is following:
 - 1) First, set F0-01 as 0: the control mode selects the keyboard control.
 - 2) Set F1-00 by encoder type as 0: SIN/COS or 1: UVW. Then set F1-01, F1-02, F1-03, F1-04, F1-05 according to the nameplate parameters of motor.
 - 3) Completely separate the motor from the load (rope), the parameter F1-11 selects 1: Initial angle tuning (Synchronous motor). Then press RUN of the operation panel and the motor can automatically run. The controller automatically counts the F1-06 encoder initialized angle. The motor tuning is then over. Operate the tuning more than 3 times, then compare F1-06 encoder initialized angle already gained, make sure the error tolerance is within the range of $\pm 5^\circ$.
 - 4) After tuning, check the running direction and current directly through the inspection running. If motor isn't running right, please repeat step 1, 2, 3 after transposing direction of encode signal.
- Automatically tuning step of permanent-magnet synchronous loaded motor is following:
 - 1) The car is located in the central of the shaft
 - 2) Meet the requirements of the inspection running
 - 3) Set F1-00 by encoder type as 0: SIN/COS or 1: UVW. Then set F1-01, F1-02, F1-03, F1-04, F1-05 according to the nameplate parameters of motor. Then inspection running, the controller counts the F1-06 coder initial angle automatically. The motor tuning is then over. Operate the tuning more than 3 times, then compare F1-06 encoder initialized angle already gained, make sure the error tolerance is within the range of $\pm 5^\circ$.

F1-12	Encoder pulse number per rotation	Factory default value	1024	Min. Unit	1
--------------	--	-----------------------	------	-----------	---

	Setting Range	0~10000
--	---------------	---------

It can set the pulse number of each rotation of the coder, according to the nameplate of coder.

Note: The motor will work normally only after setting the coder pulse correctly under the closed-loop condition . If the asynchronous motor still cannot work normally after the encoder pulse number set correctly, please exchange the connection line between the phase A and B of the coder. The coder pulse number of permanent-magnet synchronous motor must be set according to the encode when adapt U,V,W coder, and the pulse number per rotation should be set according to the encoder nameplate.

F1-13	Encoder failure monitoring times	Factory default value	3.0s	Min. Unit	0.1s
	Setting Range	0.0~10.0s			

It can set monitoring time when encode fault occurs. After lift starts running with speed of nonzero, the system begins to receive signal of encoder every time of F1-13 setting. If there's none signal input, the system will show E20 which means encoder failure. If it is < 1s , the inspection function is invalid.

6.3 Group F2 Vector Control Parameter

Function code	Name	Factory Default value	Min. Unit	Setting Range
F2-00	Proportional gain 1 of speed loop	40	1	0~100
F2-01	Integrate time 1 of speed loop	0.60s	0.01s	0.01~10.00s
F2-02	Switching frequency 1	2.00Hz	0.01Hz	0.00~F2-05
F2-03	Proportional gain 2 of speed loop	35	1	1~100
F2-04	Integration time 2 of speed loop	0.80s	0.01s	0.01~10.00s
F2-05	Switching frequency 2	5.00Hz	0.01Hz	F2-02~F0-05

The parameters of F2-00 and F2-01 decide the dynamic response characteristic of the frequency that is smaller than the switching frequency 1 (F2-02), while the parameters of F2-03 and F2-04 decide the dynamic response characteristic of the frequency that is larger than the switching frequency 2 (F2-05). The dynamic response characteristic parameters of the frequency between the switching frequency 1 and switching frequency 2 equal to the weighted average value of two set of F2-00,F2-01 and F2-03,F2-04. As shown in Fig. 6-2:

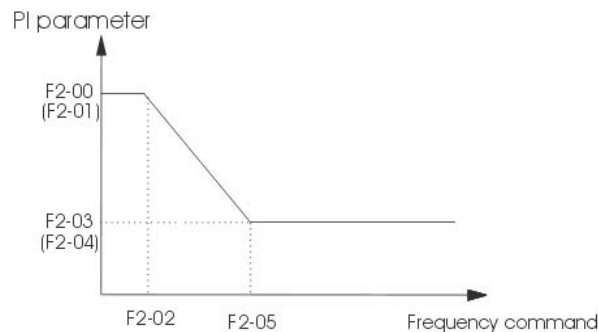

Fig. 6-2 PI Parameters Schematic Diagram

It can regulate the speed dynamic response characteristic of the vector control by setting the proportional coefficient and integrating time of the speed regulator. It can accelerate the dynamic response of the speed loop by increasing the proportional gain or decreasing the integrating time. Too large proportional gain or too small integrating time will cause the system to vibrate.

The regulating methods are recommended as follows:

If the factory parameters cannot satisfy the requirements, conduct minor adjustment on the basis of the factory parameters:

Enlarge the proportional gain first to prevent the system from vibrating, and then diminish the integrating time to ensure that the system has fast response characteristic and small overshoot.

If switching frequency 1 and switching frequency 2 are set as 0 at the same time, only F2-03 and F2-04 are virtual value.

Note: Once the PI parameters are set inappropriately, it will cause large

overshoot speed and even voltage fault when the overshoot returns to the normal level.

F2-06	Proportional gain of current loop	Factory Default value	60%	Min. Unit	1%
	Setting Range	100~500%			
F2-07	Integral gain of current loop	Factory Default value	30%	Min. Unit	1%
	Setting Range	100~500%			

F2-06, F2-07 are current loop adjusting parameters in the vector control arithmetic of synchronous motor. The adjustment in the synchronous motor has a obvious effect on the feeling of comfort. Appropriate adjustment can restrain the vibration while the lift is running. The adjusting method is the similar with that of parameter of speed loop P1.

F2-08	Upper limit of torque	Factory Default value	150.0%	Min. Unit	0.1%
	Setting Range	0.0~200.0%			

It can set upper limit of torque of motor. The setup 100% corresponds to the rated torque of the motor that matches the system.

F2-10	Running direction	Factory Default value	0	Min. Unit	s1
	Setting Range	0,1			

0: the same direction

1: opposite direction, reversed position pulse

2: The same running direction, reserved position pulse

3: opposite running direction, same position pulse

6.4 Group F3 Running Control Parameters

F3-00	Starting speed	Factory Default value	0.000m/s	Min. Unit	0.001m/s
-------	-----------------------	------------------------------	----------	-----------	----------

	Setting Range	0.000~0.030m/s			
F3-01	Retention time	Factory Default value	0.000s	Min. Unit	0.001s
	Setting Range	0.000~0.500s			

Setting of starting speed can reinforce the ability to overcome the static friction. If the setting of starting speed is too big, it can generate impact feeling at starting time. The using of two parameters can smooth the lift starting.

F3-02	Acceleration	Factory Default value	0.300m/s ²	Min. Unit	0.001m/s ²
	Setting Range	0.200~0.800m/s ²			
F3-03	Inflexion speedup time 1	Factory Default value	2.500s	Min. Unit	0.001s
	Setting Range	0.300~4.000s			
F3-04	Inflexion speedup time 2	Factory Default value	2.500s	Min. Unit	0.001s
	Setting Range	0.300~4.000s			

The three function codes decide the S curve parameters of lift speedup running:

F3-02 is acceleration of S curve of lift speedup running.

F3-03 is the time which is cost from 0 to the parameter F3-02 of S curve speedup stage. The bigger this parameter is, the slower curve inflexion is.

F3-04 is the time which is taken from the change of acceleration from 0 to that of F3-02 in the S curve speedup stage. The bigger this parameter is, the slower the flatter the curve inflexion is.

F3-05	Deceleration	Factory Default value	0.300m/s ²	Min. Unit	0.001m/s ²
	Setting Range	0.200~0.800m/s ²			

F3-06	Inflexion slow-down time 1	Factory Default value	2.500s	Min. Unit	0.001s
	Setting Range	0.300~4.000s			
F3-07	Inflexion slow-down time 2	Factory Default value	2.500s	Min. Unit	0.001s
	Setting Range	0.300~4.000s			

The three function codes decide the S curve parameters of lift slow-down running:

F3-05 is deceleration of S curve of lift slow-down running.

F3-06 is the time which is taken from the change of deceleration from F3-05 to 0 in the S curve slow-down stage. The bigger this parameter is, the flatter the curve inflexion is.

F3-07 is the time which is taken from the change of deceleration from 0 to that of F3-05 in the S curve slow-down stage. The bigger this parameter is, the flatter the curve inflexion is.

The setting of S curve is as follows:

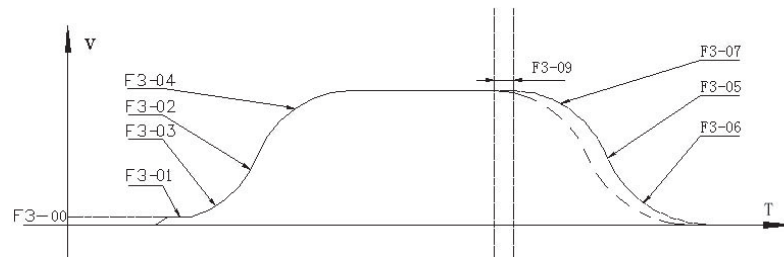

Fig. 6-3 Speed Curve Fig.

F3-08	Special deceleration	Factory Default value	0.500m/s ²	Min. Unit	0.001m/s ²
	Setting Range	0.500~2.000m/s ²			

This parameter sets the deceleration of the lift forced reducer, and deceleration in the condition of shaft-tuning and maintaining. If pulse numbers are far different from the budget numbers as lift force reducer acting, lift speed-down to 0.1m/s by special deceleration and travel to leveling position.

The setting of this parameter is: $F3-08 \geq \frac{(F0 - 03)^2}{2 \times (F3 - 13)}$, adjust according to the actual situation.

F3-09	Stop distance allowance	Factory Default value	0.0mm	Min. Unit	0.00mm
	Setting Range	0~90.0mm			

It means the advanced distance of lift distance control when the lift is slow-down. It is used to clear up the influence of coder signal missing or leveling signal delaying. Generally needs no user's modification

F3-10	Re-leveling speed	Factory Default value	0.040m/s	Min. Unit	0.001m/s
	Setting Range	0.000~0.080m/s			

It means the re-leveling speed when the lift is in the door zone. Because the length of leveling plate is different in different system, the parameter adjusting can assure the landing accuracy of re-leveling. It is used when there is the function of re-leveling of door-open.

F3-11	Low-speed running	Factory Default value	0.250m/s	Min. Unit	0.001m/s
	Setting Range	0.100~0.500m/s			

It can set the low speed of running when the lift is running in inspection or shaft self-tuning.

F3-12	Switch position of	Factory	0.00m	Min. Unit	0.01m
--------------	---------------------------	----------------	-------	-----------	-------

	the NO.1 up forced deceleration	Default value			
	Setting Range	0.00~300.00m			
F3-13	Switch position of the NO.1 down forced deceleration	Factory Default value	0.00m	Min. Unit	0.01m
	Setting Range	0.00~300.00m			

The system can automatically monitor the running speed when lift run to the switching position of forced deceleration, and prevent car and counterweight from resting the buffer and plate because of the abnormality speed.

This parameter of distance means the distance from switch position to the lowest floor. It can self-motion note according to the lift self-tuning.

S means the setting distance of switch of forced deceleration to leveling position. The distance S must be enough for the deceleration from F3-08 to 0. That means S must suffice following conditions:

$$S > \frac{V^2}{2 * F3 - 08}$$

If the distance of forced deceleration is too short, the system will alarm failure E45 after lift self-tuning .It can be solved through increasing the distance of switch position of forced deceleration or parameter F3-08.

Advised position : 1.5m

F3-14	Time of starting output with zero speed	Factory Default value	0.200s	Min. Unit	0.001s
	Setting Range	0.000~1.000s			

To protect lift starting ride comfort, the lift control can run with zero speed before brake opening. At this time, motor is in excitation, and it outputs bigger starting torque.

F3-15	Delay time of curve running	Factory Default value	0.200s	Min. Unit	0.001s
--------------	------------------------------------	------------------------------	--------	-----------	--------

	Setting Range	0.000~1.000s
--	---------------	--------------

This parameter sets time that it takes from the system outputting open signal to the brake complete opening. It usually needs about 200ms. The system keeps up outputting with zero speed.

F3-16	Delay time of end running	Factory Default value	0.300 s	Min. Unit	0.001s
	Setting Range	0.000~1.000s			

It means holding time of zero speed when the curve running ends. Generally needs no user's modification.

In running course, the connection of each signal with curve is as follows:

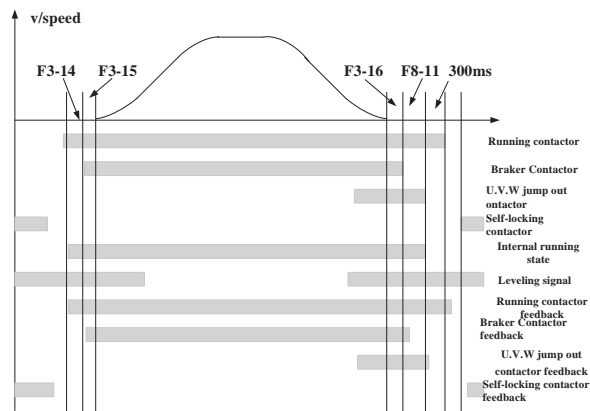

Fig. 6-4 Running time sequence Fig.

6.5 Group F4 Position Parameters

F4-00	Leveling adjusting	Factory Default value	30mm	Min. Unit	1mm
	Setting Range	0~60mm			

It can display the landing accuracy of lift. If the position of leveling inductor isn't in the middle of inductor plate when the lift stops, adjust this parameter. If lift is over leveling when stops, reduce the value of F4-00. If

lift is under leveling when stops, increase it. The parameter is set by the length of leveling plate.

F4-01	Current floor	Factory Default value	1	Min. Unit	1
	Setting Range	The lowest floor(F6-01)~The highest floor(F6-00)			

It can display the current floor of car.

The system can self-motion recompose this parameter when lift is running. And the system can automatically revise this parameter at leveling position after touching switch of up or down forced deceleration. When lift is in non-bottom or non-top floor, users can hand recompose this parameter. But this parameter must accord with the current floor.

Function code	Name	Factory default value	Min. Unit	Setting Range
F4-02	High bit of current floor	1	1	0~65535
F4-03	Low bit of current floor	34464	1	0~65535

It can display the number of pulse that the current floor relative to the lowest leveling floor.

Function code	Name	Factory default value	Min. Unit	Setting Range
F4-04	Length 1 of leveling plate	0	1	0~65535
F4-05	Length 2 of leveling plate	0	1	0~65535

It can display the pulse number of leveling plate's practical length. It is noted when self-tuning in well. Users can adjust it according to practical status.

Function code	Name	Factory default value	Min. Unit	Setting Range
F4-06	High bit of floor high 1	0	1	0~65535

Function code	Name	Factory default value	Min. Unit	Setting Range
F4-07	Low bit of floor high 1	0	1	0~65535
⋮	⋮	⋮	⋮	⋮
F4-22	High bit of floor high 9	0	1	0~65535
F4-23	Low bit of floor high 9	0	1	0~65535

The bit of floor height means the pulse number of height between floor i leveling plate to floor (i+1) leveling plate. Every height corresponds to one number of 32 bit numbers in binary system. Among those, high 16 bit parallels high bit of this floor height, and low 16 bit parallels low bit of this floor height.

For example: the floor height from floor 4 to floor 5 is F4-12=6, F4-13=54321. In binary it shows as follows:

0000, 0000, 0000, 0110, 1101, 0100, 0011, 0001

Practical pulse number will be displayed as 447537 in decimal system.

Shaft parameter self-tuning, is applied to record the switch position of the shaft.

The shaft self-tuning should meet the following requirements:

1. The feedback of coder and leveling sensor is normal, the shaft switch installed properly
2. The lift is located in the lowest floor, and the forced deceleration switch is working
3. The lift is in the inspection state and can undergoing the inspection running
4. The highest and lowest floor is set properly
- 5 The NICE 1000 is not in the error warning state

User can set the lift into self-tuning state by pressing the S1 button for 1s.

6.6 F5 Group Terminal Input Function Parameters

Function code	Name	Factory default value	Min. Unit	Setting Range
F5-00	Attendant control and automatic control switching time	3s	1	1~200s

When there's call from other floors in attendant state, it will turn to the normal state automatically after F5-00 time if no one operates; then return to attendant state after the running.

When the parameter of F5-00 is smaller than 5, the mentioned function is cancelled, then it's the same as the normal attendant function.

Function code	Name	Factory default value	Min. Unit	Setting Range
F5-01	Function selection of terminal X1	03	1	00~199
F5-02	Function selection of terminal X2	104	1	00~199
⋮	⋮	⋮	⋮	⋮
F5-23	Function selection of terminal X23	00	1	00~199
F5-24	Function selection of terminal X24	00	1	00~199

X1~X24 is switch input terminal, and they can select corresponding function codes 00~199. The same function code can't be used repeatedly. If the terminal X1 input signal is 24V, the signal light X1 of the main operation panel will light. The rest may be deduced by analogy. The code of every function is as follows:

00: Not in use

The controller does not respond even if the signal is inputted. Set the unused terminals as 00 to prevent error activation.

01: Leveling 1 signal 02: Leveling 2 signal 03: Door zone signal

The system can control lift leveling stopping by signal of leveling inductor. The system can support 3 leveling models: up level inductor + down level inductor, up level inductor + down level inductor + door zone inductor or only door zone level inductor. If the leveling inductor signal is deviant (conglutination or cut-off), the system will indicate E22 error.

04: Running output feedback signal05: Brake output feedback 1signal06: Brake output feedback 2signal

The system monitors the signal of running feedback and brake feedback after 2s when the running contactor is cut off. It's used to judge whether the contactor is picked-up or not.

07: U.V.W jump-out feedback signal

It controls the synchronous motor's U.V.W jump out contactor. When the lift is in power failure emergency running state, if the traction motor is permanent-magnet synchronous motor and is automatically emergency running, the brake opens, and relevant terminal outputs, which make the lift self-motion slide running to the nearest leveling and then open the door. Details are in chapter7. In addition, the function increases the safety when the lift stops in a normal state.

08: Door lock jump out output feedback signal

The system outputs the pick-up command for the door lock jump out contactor, to fulfill pre-opening, door lock jump-out and releasing control when leveling after opening.

09: Inspection signal 10: Inspection up signal11: Inspection down signal

When the "Auto/ Inspection" switch points to "Inspection", lift comes into inspection state, the system cancel all auto running include auto-door operation. When input inspection up or down running signal, lift will run with

inspection speed.

12: Once fire signal

When the “fire” switch is open, lift comes into fire state. The system will cancel all entered landing call and car call; the lift will park at the next land and pass the fire landing without opening the door. Lift won't open door for setting passengers free until arriving at the fire landing base.

13: Reserved

14: Lift lock signal

Lift lock signal input point, the signal is valid, the system gets into lift-lock state.

15: Up limit signal

16: Down limit signal

The signals of up limit and down limit are the terminal stopping switches for preventing car resting the buffer when the lift passed the leveling station of landing without stopping.

17: Up forced deceleration signal

18: Down forced deceleration signal

These functional codes set input point into N.O. input of forced deceleration, corresponding to the forced deceleration switch signal. NICE 1000 system records these positions of switches into parameters of F3 group.

19: Over loading signal

If the lift loading is over 110% of rated load, the system comes into over loading state. The over loading buzzer tweets, the car light of over loading lights and lift doesn't close the door. If the door lock is closed, the over loading signal is impotent. In the lift checking course, if the system need run with 110% over loading, it can set F6-10=4 to control.

20: Full loading signal

The lift loading among 80%~110% is full loading state, the land hall lantern shows full loading, the lift doesn't answer the hall call.

21: Urgent stop (Safety feedback) signal

Safety circuit is the core guarantee of the lift's reliable running.

22: Door 1 open limit signal

Relevant terminal is used to receive the open door arrival signal 1.

23: Door 2 open limit signal

Relevant terminal is used to receive the open door arrival signal 2.

24: Door 1 close limit signal

Relevant terminal is used to receive the close door arrival signal 1.

25: Door 2 close limit signal

Relevant terminal is used to receive the close door arrival signal 2.

26: Door 1 light curtain signal

This function code terminal setting is used for the light curtain 1 signal receiving.

27: Door 2 light curtain signal

This function code terminal setting is used for the light curtain 2 signal receiving.

28: Attendant signal

If the signal is valid, the lift will get into attendant operation state.

29: Direct arrival signal

In attendant state, if the direct arrival signal is valid, the lift won't respond to the external call.

30: Direction changing signal

In attendant state, if the signal is valid, the lift switches the running direction.

31: Independent running signal

If the signal is valid, the lift gets off parallel.

32: Door 2 selection signal

In the open-through door control, if door switch is controlled by car switch or button, corresponding input terminal will receive the signal. If the signal

is valid, the system will open and close door 2. If the signal is not valid, the system will open and close door 1.

33: UPS input valid

The corresponding input terminal is used to receive power failure emergency running signal.

34: Open button

The open command input signal

35: close button

Close command input signal

36: safety circuit

Safety circuit is the reliable guarantee for lift running

37: door lock circuit 1

Door lock ensure the close of hall door and car door when lift running

38: door lock circuit 2

Same function as circuit 1, convenient to distinguish the hall door signal and car door signal. The system will identify the door lock closed only when the 2 lock feedback signal are connected

39: half-loaded signal

The signal is valid when the car load is excess half . key signal to judge running direction in emergency running.

40-99 reserved

101~109

These 99 parameters are corresponding with parameters 01~99. The parameters 01~99 input terminal are set as N.O. input, but the parameters 101~199 are set as N.C. input.

Function code	Name	Default	Min. Unit	Setting Range
F5-25	X25 strong power input function	01	1	00~99

Function code	Name	Default	Min. Unit	Setting Range
	selection			
F5-26	X26 strong power input function selection	02	1	00~99
F5-27	X27 strong power input function selection	03	1	00~99

00: Not in use

The system won't respond even though there's signal inputted. Set the unused terminal as 00 in order to prevent from miss-action.

01: Safety circuit signal

Set the terminal of this function to detect safety circuit strong power feedback.

02: Door lock circuit 1 signal

Set the terminal of this function to detect door lock circuit strong power feedback. It can be used in hall door circuit and car door lock circuit.

03: Door lock circuit 2 signal

Set the terminal of this function to detect door lock circuit strong power feedback. It can be used in hall door circuit and car door lock circuit.

04~99: Reserved

Function code	Name	Default	Min. Unit	Setting Range
F5-28	Input and output terminal state display 1			
F5-29	Input and output terminal state display 2			

When users enter F5-28 menu, the tube on the keyboard shows the output terminal state at present. The keyboard tube order is 5, 4,3,2,1 from left to right. Every passage's definition is as follows:

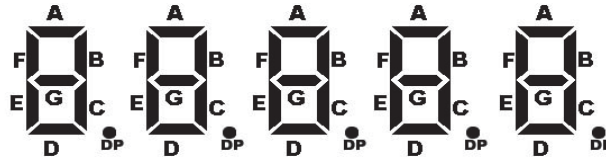

F5-28 expresses the state 1 of the input or output terminal. Its meanings are listed in the following Fig.s:

Tube sequence	Tube passage marker	Tube passage meaning	Tube passage "light" meaning
1	A	Not in use	Meaningless
	B	Leveling 1 signal	Leveling 1 signal availability
	C	Leveling 2 signal	Leveling 2 signal availability
	D	Door zone signal	Door zone signal availability
	E	Run output feedback signal	Run output feedback signal availability
	F	Brake output feedback 1 signal	Brake output feedback 1 signal availability
	G	Brake output feedback 2 signal	Brake output feedback 2 signal availability
	DP	U.V.W jump out feedback signal	Synchronous motor U.V.W jump out feedback signal availability
2	A	Enclosed door output feedback signal	Enclosed door output feedback signal availability
	B	Inspection signal	Inspection signal availability
	C	Inspection up signal	Inspection up signal availability
	D	Inspection down signal	Inspection down signal availability
	E	Once fire signal	Once fire signal availability
	F	Reserved	Reserved
	G	Lock lift signal	Lock lift signal availability
	DP	Up limit signal	Up limit signal availability
3	A	Down limit signal	Down limit signal availability
	B	Up force reducer signal	Up force reducer signal availability
	C	Down force reducer signal	Down force reducer signal availability

Tube sequence	Tube passage marker	Tube passage meaning	Tube passage "light" meaning
	D	Over load signal	Over load signal availability
	E	Full load signal	Full load signal availability
	F	Urgent stop (safety feedback) signal	Urgent stop (safety feedback) signal availability
	G	Door 1 open limit signal	Door 1 open limit signal availability
	DP	Door 2 open limit signal	Door 1 open limit signal availability
4	A	Door 1 close limit signal	Door 1 close limit signal availability
	B	Door 2 close limit signal	Door 2 close limit signal availability
	C	Door 1 light curtain signal	Door 1 light curtain signal availability
	D	Door 2 light curtain signal	Door 2 light curtain signal availability
	E	Motorman signal	Motorman signal availability
	F	Direct arrival signal	Direct arrival signal availability
	G	Direction changing signal	Direction changing signal availability
	DP	Independent running signal	Independent running signal availability
5	A	Door 2 selection signal	Door 2 selection signal availability
	B	UPS input valid	UPS input valid
	C	Open button	Open signal valid
	D	Close button	Close button valid
	E	Door lock circuit1	Door circuit 1 valid
	F	Door circuit 2	Door circuit 2 valid
	G	Half load signal	Half load signal valid
	DP	Not in use	Meaningless

F5-29 expresses the state 2 of the input or output terminal. Its meanings are listed in the following Fig.s:

Tube sequence	Tube passage marker	Tube passage meaning	Tube passage "light" meaning
1	A	Not in use	Meaningless
	B	Safety circuit signal	Safety circuit signal availability
	C	Door lock circuit 1 signal	Door lock circuit 1 signal availability
	D	Door lock circuit 2 signal	Door lock circuit 2 signal availability
	E	Not in use	Meaningless
	F	Not in use	Meaningless
	G	Not in use	Meaningless
	DP	Not in use	Meaningless
2	A	Y0 output	Y0 output availability
	B	Running contactor output	Running contactor output availability
	C	Brake contactor output	Brake contactor output availability
	D	Brake forced output	Brake forced output availability
	E	Illumination and fan output	Illumination and fan output availability
	F	Synchronous motor U.V.W jump out output	Synchronous motor U.V.W jump out output availability
	G	Door1 open output	Door1 open output availability
	DP	Door1 close output	Door1 close output availability
3	A	Door2 open output	Door2 open output availability
	B	Door2 close output	Door2 close output availability
	C	Low 7 segment code a display output	Low 7 segment code a display output availability
	D	Low 7 segment code b display output	Low 7 segment code b display output availability
	E	Low 7 segment code c display output	Low 7 segment code c display output availability
	F	Low 7 segment	Low 7 segment code d

Tube sequence	Tube passage marker	Tube passage meaning	Tube passage "light" meaning
		code d display output	display output availability
	G	Low 7 segment code e display output	Low 7 segment code e display output availability
	DP	Low 7 segment code f display output	Low 7 segment code f display output availability
4	A	Low 7 segment code g display output	Low 7 segment code g display output availability
	B	Up arrowhead display output	Up arrowhead display output availability
	C	Down arrowhead display output	Down arrowhead display output availability
	D	Minus display output	Minus display output availability
	E	Fire to main landing signal output	Fire to main landing signal output availability
	F	Buzzer control output	Buzzer control output availability
	G	Over load output	Over load output availability
	DP	Arrival gong output	Arrival gong output availability
5	A	Full load output	Full load output availability
	B	Inspection output	Inspection output availability
	C	Illumination and fan Output 2	Illumination and fan Output 2 availability
	D	Enclosed door contactor output	Enclosed door contactor output availability
	E	BCD, Gray code , 7 block code high bit output	BCD, Gray code , 7 block code high bit output availability
	F	Integrated running normal output	Integrated running normal output
	G	Not in use	Meaningless
	DP	Not in use	Meaningless

Function code	Name	Default	Min. Unit	Setting Range
F5-30	Floor input and output terminal state display 1			
F5-31	Floor input and output terminal state display 2			

When users enter F5-30 menu, the tube on the keyboard shows the output terminal state at present. The keyboard tube order is 5, 4,3,2,1 from left to right. Every passage's definition is as follows:

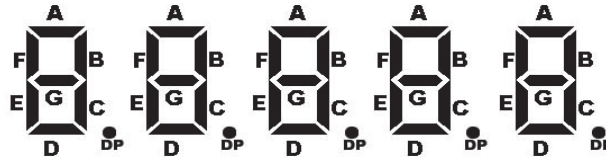

F5-30 expresses the state 1 of the floor input or output terminal. Its meanings are listed in the following Fig.s:

Tube sequence	Tube passage marker	Tube passage meaning	Tube passage "light" meaning
1	A	Door 1 open button input and output	Door 1 open button input and output availability
	B	Door 1 close button input and output	Door 1 close button input and output availability
	C	Door 1 open delaying button input and output	Door 1 open delaying button input and output availability
	D	Internal call of door 1 on the 1 st floor input and output	Internal call of door 1 on the 1 st floor input and output availability
	E	Internal call of door 1 on the 2 nd floor input and output	Internal call of door 1 on the 2 nd floor input and output availability
	F	Internal call of door 1 on the 3 rd floor input and output	Internal call of door 1 on the 3 rd floor input and output availability
	G	Internal call of door	Internal call of door 1 on the 4 th

Tube sequence	Tube passage marker	Tube passage meaning	Tube passage "light" meaning
		1 on the 4 th floor input and output	floor input and output availability
	DP	Internal call of door 1 on the 5 th floor input and output	Internal call of door 1 on the 5 th floor input and output availability
2	A	Internal call of door 1 on the 6 th floor input and output	Internal call of door 1 on the 6 th floor input and output availability
	B	Internal call of door 1 on the 7 th floor input and output	Internal call of door 1 on the 7 th floor input and output availability
	C	Internal call of door 1 on the 8 th floor input and output	Internal call of door 1 on the 8 th floor input and output availability
	D	Internal call of door 1 on the 9 th floor input and output	Internal call of door 1 on the 9 th floor input and output availability
	E	Internal call of door 1 on the 10 th floor input and output	Internal call of door 1 on the 10 th floor input and output availability
	F	Reserved	Reserved
	G	Not in use	Meaningless
	DP	Not in use	Meaningless
3	A	Up call of door 1 on the 1 st floor input and output	Up call of door 1 on the 1 st floor input and output availability
	B	Reserved	Reserved
	C	Up call of door 1 on the 2 nd floor input and output	Up call of door 1 on the 2 nd floor input and output availability
	D	Down call of door 1 on the 2 nd floor input and output	Down call of door 1 on the 2 nd floor input and output availability
	E	Up call of door 1 on the 3 rd floor input and output	Up call of door 1 on the 3 rd floor input and output availability

Tube sequence	Tube passage marker	Tube passage meaning	Tube passage "light" meaning
	F	Down call of door 1 on the 3 rd floor input and output	Down call of door 1 on the 3 rd floor input and output availability
	G	Up call of door 1 on the 4 th floor input and output	Up call of door 1 on the 4 th floor input and output availability
	DP	Down call of door 1 on the 4 th floor input and output	Down call of door 1 on the 4 th floor input and output availability
4	A	Up call of door 1 on the 5 th floor input and output	Up call of door 1 on the 5 th floor input and output availability
	B	Down call of door 1 on the 5 th floor input and output	Down call of door 1 on the 5 th floor input and output availability
	C	Up call of door 1 on the 6 th floor input and output	Up call of door 1 on the 6 th floor input and output availability
	D	Down call of door 1 on the 6 th floor input and output	Down call of door 1 on the 6 th floor input and output availability
	E	Up call of door 1 on the 7 th floor input and output	Up call of door 1 on the 7 th floor input and output availability
	F	Down call of door 1 on the 7 th floor input and output	Down call of door 1 on the 7 th floor input and output availability
	G	Up call of door 1 on the 8 th floor input and output	Up call of door 1 on the 8 th floor input and output availability
	DP	Down call of door 1 on the 8 th floor input and output	Down call of door 1 on the 8 th floor input and output availability
5	A	Up call of door 1 on the 9 th floor input and output	Up call of door 1 on the 9 th floor input and output availability

Tube sequence	Tube passage marker	Tube passage meaning	Tube passage "light" meaning
	B	Down call of door 1 on the 9 th floor input and output	Down call of door 1 on the 9 th floor input and output availability
	C	Reserved	Reserved
	D	Down call of door 1 on the 10 th floor input and output	Down call of door 1 on the 10 th floor input and output
	E	Reserved	Reserved
	F	Reserved	Reserved
	G	Not in use	Meaningless
	DP	Not in use	Meaningless

F5-31 expresses the state 2 of the floor input or output terminal. Its meanings are listed in the following Fig.s:

Tube sequence	Tube passage marker	Tube passage meaning	Tube passage "light" meaning
1	A	Door 2 open button input and output	Door 2 open button input and output availability
	B	Door 2 close button input and output	Door 2 close button input and output availability
	C	Door 2 open delaying button input and output	Door 2 open delaying button input and output availability
	D	Internal call of door 2 on the 1 st floor input and output	Internal call of door 2 on the 1 st floor input and output availability
	E	Internal call of door 2 on the 2 nd floor input and output	Internal call of door 2 on the 2 nd floor input and output availability
	F	Internal call of door 2 on the 3 rd floor input and output	Internal call of door 2 on the 3 rd floor input and output availability
	G	Internal call of door 2 on the 4 th floor input and output	Internal call of door 2 on the 4 th floor input and output availability
	DP	Internal call of door	Internal call of door 2 on the 5 th

Tube sequence	Tube passage marker	Tube passage meaning	Tube passage "light" meaning
		2 on the 5 th floor input and output	floor input and output availability
2	A	Internal call of door 2 on the 6 th floor input and output	Internal call of door 2 on the 6 th floor input and output availability
	B	Internal call of door 2 on the 7 th floor input and output	Internal call of door 2 on the 7 th floor input and output availability
	C	Internal call of door 2 on the 8 th floor input and output	Internal call of door 2 on the 8 th floor input and output availability
	D	Internal call of door 2 on the 9 th floor input and output	Internal call of door 2 on the 9 th floor input and output availability
	E	Internal call of door 2 on the 10 th floor input and output	Internal call of door 2 on the 10 th floor input and output availability
	F	Reserved	Reserved
	G	Not in use	Meaningless
	DP	Not in use	Meaningless
3	A	Up call of door 2 on the 1 st floor input and output	Up call of door 2 on the 1 st floor input and output availability
	B	Reserved	Reserved
	C	Up call of door 2 on the 2 nd floor input and output	Up call of door 2 on the 2 nd floor input and output availability
	D	Down call of door 2 on the 2 nd floor input and output	Down call of door 2 on the 2 nd floor input and output availability
	E	Up call of door 2 on the 3 rd floor input and output	Up call of door 2 on the 3 rd floor input and output availability
	F	Down call of door 2 on the 3 rd floor input and output	Down call of door 2 on the 3 rd floor input and output availability

Tube sequence	Tube passage marker	Tube passage meaning	Tube passage "light" meaning
	G	Up call of door 2 on the 4 th floor input and output	Up call of door 2 on the 4 th floor input and output availability
	DP	Down call of door 2 on the 4 th floor input and output	Down call of door 2 on the 4 th floor input and output availability
4	A	Up call of door 2 on the 5 th floor input and output	Up call of door 2 on the 5 th floor input and output availability
	B	Down call of door 2 on the 5 th floor input and output	Down call of door 2 on the 5 th floor input and output availability
	C	Up call of door 2 on the 6 th floor input and output	Up call of door 2 on the 6 th floor input and output availability
	D	Down call of door 2 on the 6 th floor input and output	Down call of door 2 on the 6 th floor input and output availability
	E	Up call of door 2 on the 7 th floor input and output	Up call of door 2 on the 7 th floor input and output availability
	F	Down call of door 2 on the 7 th floor input and output	Down call of door 2 on the 7 th floor input and output availability
	G	Up call of door 2 on the 8 th floor input and output	Up call of door 2 on the 8 th floor input and output availability
	DP	Down call of door 2 on the 8 th floor input and output	Down call of door 2 on the 8 th floor input and output availability
5	A	Up call of door 2 on the 9 th floor input and output	Up call of door 2 on the 9 th floor input and output availability
	B	Down call of door 2 on the 9 th floor input and output	Down call of door 2 on the 9 th floor input and output availability

Tube sequence	Tube passage marker	Tube passage meaning	Tube passage "light" meaning
	C	Reserved	Reserved
	D	Down call of door 2 on the 10 th floor input and output	Down call of door 2 on the 10 th floor input and output
	E	Reserved	Reserved
	F	Reserved	Reserved
	G	Not in use	Meaningless
	DP	Not in use	Meaningless

6.7 Group F6 Lift Basic Parameters

Function code	Name	Default	Min. Unit	Setting Range
F6-00	The highest floor	5	1	F6-01~10
F6-01	The lowest floor	1	1	1~F6-00
F6-02	Parking floor	1	1	F6-01~F6-00

When the system not in using time is over the F9-00 setting value, lift can return parking floor by itself.

F6-03	Fire base floor	Default	1	Min. Unit	1
	Setting Range	The lowest landing(F6-01)~The highest landing(F6-00)			

The lift will return to the landing when the system is in fire landing state.

F6-04	locking landing	Default	1	Min. Unit	1
	Setting Range	The lowest landing(F6-01)~The highest landing(F6-00)			

When lift is in locking state, it will return to this landing after completing control box command.

Function code	Name	Default	Min. Unit	Setting Range
F6-05	service floor	1023	1	0~1023

F6-05 set what kind of floors' command the lift responds throughout the

floors.

The floor service is controlled by binary system number of 10 bit. The binary system number express the floor 1~10 from low bit to high bit, The setting relevant bit 1 express that lift responds to this floor's calling, and the setting relevant bit 0 express that lift doesn't respond to this floor's calling. For example, floors in need of service are listed as follows:

Binary digit	Relevant floor	Service or not	Binary bit setting	Binary digit	Relevant floor	Service or not	Binary bit setting
Bit0	Floor 1	ON	1	Bit5	Floor 6	ON	1
Bit1	Floor 2	OFF	0	Bit6	Floor 7	ON	1
Bit2	Floor 3	ON	1	Bit7	Floor 8	OFF	0
Bit3	Floor 4	ON	1	Bit8	Floor 9	OFF	0
Bit4	Floor 5	ON	1	Bit9	Floor 10	ON	1

The relevant binary digit setting is added in the list. The binary bit is 1001111101, and the relevant algorithm number is 637, so F6-05 should be set as 637.

F6-09	Testing times at random	Default	0	Min. Unit	1
	Setting Range	0~60000			

It's used to test the lift's running. If the function is valid, the lift can select the floor at random to run automatically, until the setting times are completed.

F6-10	Selection of enabled function testing	Default	0	Min. Unit	1
	Setting Range	Bit0: External call ignored function Bit1: Open door enabled function Bit2: Overloading enabled function Bit3: Limit enabled function			

Bit0: External call ignored function. If the bit is set as 1, it won't respond to

the external call, and it returns to 0 automatically if power failure occurs in this bit.

Bit1: Open door enabled function. If the bit is set as 1, it won't open the door automatically, and it returns to 0 automatically if power failure occurs in this bit.

Bit2: Overloading enabled function. If the bit is set as 1, the function is invalidation, and it returns to 0 automatically if power failure occurs in this bit in order to facilitate 110% running.

Bit3: Limit enabled function. If the bit is set as 1, the function is invalidation, and it returns to 0 automatically if power failure occurs in this bit in order to facilitate test limit switch when testing. It can be only used once after setting.

Bit4~Bit15: Reserved

Note: F6-10 can only be used by the qualified persons, please pay special attention. It's claimed that setting person is responsible for the corresponding results. Please make sure that F6-10 is set as 0 when the lift is normally running.

Function code	Name	Default	Min. Unit	Setting Range
F6-11	L1 function selection	201	1	201~399
F6-12	L2 function selection	202	1	201~399
⋮	⋮	⋮	⋮	⋮
F6-35	L25 function selection	00	1	201~399
F6-36	L26 function selection	00	1	201~399

Selection of the floors' button inputting:

201~203 (Door 1 switch the door) 204~209 (Reserved)

210~219 (Door 1 internal call) 220~229 (Door 1 up external call)

230~239 (Door 1 down external call) 240~299 (Reserved)

301~399 (Door2)

304 (door 2 selection button lamp output)

00: Not in use

201: Door 1 door opening button

202: Door 1 door closing button

203: Door 1 door opening delaying button

204 Door 2 selection button input

205~209: (Reserved)

210: Internal call of door 1 on the 10th floor

211: Internal call of door 1 on the 1st floor

212: Internal call of door 1 on the 2nd floor

213: Internal call of door 1 on the 3rd floor

214: Internal call of door 1 on the 4th floor

215: Internal call of door 1 on the 5th floor

216: Internal call of door 1 on the 6th floor

217: Internal call of door 1 on the 7th floor

218: Internal call of door 1 on the 8th floor

219: Internal call of door 1 on the 9th floor

220: (Reserved)

221: Up call of door 1 on the 1st floor

222: Up call of door 1 on the 2nd floor

223: Up call of door 1 on the 3rd floor

224: Up call of door 1 on the 4th floor

225: Up call of door 1 on the 5th floor

226: Up call of door 1 on the 6th floor

227: Up call of door 1 on the 7th floor

228: Up call of door 1 on the 8th floor

229: Up call of door 1 on the 9th floor

230: Down call of door 1 on the 10th floor

231: (Reserved)

232: Down call of door 1 on the 2nd floor

233: Down call of door 1 on the 3rd floor

234: Down call of door 1 on the 4th floor

235: Down call of door 1 on the 5th floor

236: Down call of door 1 on the 6th floor

237: Down call of door 1 on the 7th floor

238: Down call of door 1 on the 8th floor

239: Down call of door 1 on the 9th floor

240: (Reserved)

241~249: Reserved

6.8 Group F7 Terminal Output Function Parameter

Function code	Name	Default	Min. Unit	Setting range
F7-00	Y0 function selection	00	1	00~99

Y0 as the single relay output can select all the relay output function. When the lift need power failure emergency running function, F7-00 need be set as 32 in order to enable the lift automatically switch to power failure emergency running.

Function code	Name	Default	Min. Unit	Setting range
F7-01	Y1 function selection	01	1	00~05

Function code	Name	Default	Min. Unit	Setting range
F7-02	Y2 function selection	02	1	00-05
F7-03	Y3 function selection	04	1	00-05

F7-01~F7-03 can only choose:

00: Not in use

No function in output terminal

01: Run contactor output

It controls the run contactor's pick-up and release.

02: Brake contactor output

It controls the brake contactor's pick-up and release.

03: Brake forced output

It keeps outputting for 4s when each time it opens the brake in order to control the brake's starting point's pressure.

04: Illumination and fan output

It controls illumination and fan output.

05: Synchronous motor U.V.W jump out output

It controls the U.V.W jump out contactor of the permanent-magnet synchronous motor. When the synchronous motor is in power failure emergency self slide running, the brake opens, and U.V.W jump out outputs, which enable the lift self slide runs to the nearest leveling to stop. It reinforce the safety of the lift.

Function code	Name	Default	Min. Unit	Setting range
F7-04	Y4 function selection	00	1	06-99
F7-05	Y5 function selection	00	1	06-99
F7-06	Y6function selection	06	1	06-99
⋮	⋮	⋮	⋮	⋮

Function code	Name	Default	Min. Unit	Setting range
F7-23	Y23function selection	00	1	06-99

00: Not in use

06: Door 1 open door output

07: Door 1 close door output

08: Door2 open door output

09: Door2 close door output

10: Low 7 block code a display output

11: Low 7 block code b display output

12: Low 7 block code c display output

13: Low 7 block code d display output

14: Low 7 block code e display output

15: Low 7 block code f display output

16: Low 7 block code g display output

17: Up arrowhead display output

18: Down arrowhead display output

19: Minus display output

20: Fire to main landing signal output

21: Buzzer control output

22: Overloading output

23: Arrival gong output

24: Full load output

25: Inspection output

26: Illumination and fan output 2

27: Closed door contactor output

28: BCD, Gray, 7 segment code high bit output

29: Integrated normal running output

30~99: Reserved

6.9 Group F8 Reinforce Function Parameters

F8-00	Weighing self-tuning	Default	0%	Min. Unit	1%
	Setting Range	0~100%			

When NICE1000 elevator integrated controller uses analog weighing, it needs expansion card to be added.

It means the weighing self-tuning setting. There are three steps of the weighing self-tuning:

1. Ensure F8-01 setting is 0 and F8-08 chooses 2. This means that the system allow the weighing self- tuning.
2. Let lift stop at any floor, car is in non-load state, input F8-00 by setting 0,and press ENTER to input.
3. Put N% load into the car, set F8-00=n, and press ENTER to input. For example: put 100Kg heavy into lift of the rated load 1000Kg, and input F8-00=10.

After weighing self-tuning, the data of non-load and full load are written into F8-06 and F8-07.User can input data by hand based on the fact.

Note: please accord to this order. Otherwise the weighing self-tuning is invalidation.

F8-01	Preset torque selection	Default	0	Min. Unit	1
	Setting Range	0,1,2			

0: Preset torque is invalidation, weighing self-tuning is allowable.

1: Torque bias is available.

When use preset torque bias function, the system can output torque with suited load, to assure comfortable feeling of the lift. But output torque is limited by Upper limit of torque(F2-08).When load torque is over the upper limit of torque setting, the system output torque is the upper limit of torque.

2: Count pre-torque automatically

When the lift is used in no-weighing state, it will count the pre-torque compensation automatically.

F8-02	Preset torque bias Zero servo current coefficient	Default	50.0% 15%	Min. Unit	0.1%
	Setting Range	0.0~100.0% 0.2- 50%			
F8-03	Drive gain Zero servo speed loop KP	Default	0.60 0.5	Min. Unit	0.01
	Setting Range	0.00~2.00 0.00- 1.00			
F8-04	Brake gain Zero servo speed loop TI	Default	0.60 0.6	Min. Unit	0.01
	Setting Range	0.00~2.00 0.00- 2.00			

The first line of functions of the F8-02~F8-04 are applied in analog weighing to adjust the lift's starting.

If it is in full loading, the lift runs up, the motor is in drive running state; the lift runs down, the motor is in brake running state.

If it is in non-loading state, the lift runs up , the motor is in brake running state; the lift runs down, the motor is in drive running state.

The parameters for the pre-torque bias are actually the balance coefficient of the lift and it is also the percentage of the weight in the car and the rated weight when the car is in balance with the counterweight; Drive gain and brake gain are the pre-torque coefficients when the motor is in driving or brake running. The larger the compensation of the pre-torque in starting, the larger the gain will be in the same condition. The controller can identify the driving and brake state according to the signals of weight conductor, and then work out desirable torque compensation values.

When the system uses analog weighing, these group parameters are used for adjusting starting. Details of adjusting ways are as follows:

When motor is in driving state, if the lift rolls back when starts, increase F8-03; if the lift rushes to start, reduce F8-03.

When motor is in brake state, if the lift rolls back when starts, increase F8-04; if the lift rushes to start, reduce F8-04.

The second line of functions of the F8-02~F8-04 are applied in no-weighing state to adjust the lift's starting.

- a) Gradually add the 0 servo current coefficient (F8-02) value. When the brake is open make the back slide is small enough and the motor is not shaking. Please use the (FA-06) as reference to judge the back slide(1024 stands for distance of 1 teeth back slide). Generally the condition of within 1 teeth (1 person) is acceptable.
- b) If the motor is shaking when the 0 servo speed loop T1 is smaller than 1.00,please 0 servo current coefficient (F8-02)
- c) 0 servo speed loop KP(F8-03) can remain the same ,do not being too large, otherwise the motor may shaking

F8-06	Car no load setting	Default	0	Min. Unit	1
	Setting Range	0~1023			
F8-07	Car full load setting	Default	100	Min. Unit	1
	Setting Range	0~1023			

This group function codes can set the AD sampling value of analog when the car is in no load and full load condition.

Note: If F8-06=F8-07, full load and over load is invalidation.

F8-08	Weighing input selection	Default	0	Min. Unit	1
	Setting Range	0,1,2			

0: Invalidation

The lift doesn't use weighing compensation.

1: Reserved

2: Analog sampling

The lift uses analog weighing compensation.

F8-09	Power failure emergency rescue speed	Default	0.050m/s	Min. Unit	0.001m/s
	Setting Range	0.000~0.100m/s			

When the lift is in the emergency state, it will run to leveling position in the speed. Please note that the speed shouldn't be too high in the rescue course, or it may affect the normal work of UPS. The speed is determined by the power of UPS.

F8-10	Power failure emergency rescue speed	Default	0	Min. Unit	1
	Setting Range	0: Motor isn't running 1: UPS power running 2: 48V batter power			

NICE 1000 supplies three ways of emergency rescue methods, details are in chapter 7.

F8-11	Car stopping torque output delay	Default	0.200	Min. Unit	0.001
	Setting Range	0.200~1.500s			

After setting the commands of outputting brake close when the lift stops running, time for zero speed running depends on the brake.

6.10 Group F9 Time Parameters

F9-00	Free return main floor time	Default	10min	Min. Unit	1min
	Setting Range	0~240min			

It can set the time of back to the main floor when it is free. When lift doesn't receive car call, hall call or any other commands, the lift will return to the main floor.

0: This function is invalid.

F9-01	Fan and light close time	Default	2min	Min. Unit	1min
	Setting Range	0~240min			

When lift is in automatic state, no run command, the system will cut off fan and light power after this setting time.

0: This function is invalid.

F9-02	Longest interval time of running in the floor	Default	45s	Min. Unit	1s
	Setting Range	0~45s			

When lift running time is over the F9-02 setting time at border upon floors (There's no leveling signal then), lift will come into protection. When this parameter setting is less than 3s, this function is invalidation.

Function code	Name	Setting Range	Default	Min. Unit
F9-03	Accumulative working time	0~65535h	0	1
F9-05	RUN times high bit	0~9999	0	1
F9-06	RUN times low bit	0~9999	0	1

They are total accumulative actual lift working time and running times. These function parameters are read only and user isn't allowed to change them. The lift's accumulative running time is precise by hour. Lift accumulative run times = run times high bit ×10000 + run times low bit.

6.11 Group FA Keyboard Setting Parameters

Function code	Name	Setting Range	Default	Min. Unit
FA-00	Baud rate setting	0~5:9600BPS 6:19200BPS 7:38400BPS	5	1

FA-00 sets the baud rate of the serial communication. Setting 0~5 means choose 9600BPS; Setting 6 means choose 19200BPS; Setting 7 means choose 38400BPS.

FA-01	Run display	Default	65535	Min. Unit	1
	Setting Range	0~65535			

This function code is made up of a binary number with 16 digits that display 16 kinds of running state parameters. Each parameter is controlled by one binary number, "1" expresses that display this parameter, "0" expresses that don't display this parameter. If want to display parameter as the following list, relevant binary number should be set as follows:

Binary bit	Parameter	Display or not	Binary bit setting	Binary bit	Parameter	Display or not	Binary bit setting
Bit0	Running speed	Display	1	Bit8	Car load	Not display	0
Bit1	Rated speed	Display	1	Bit9	System state	Not display	0
Bit2	Bus voltage	Display	1	Bit10	Pre-torque current (%)	Not display	0
Bit3	Output voltage	Not display	0	Bit11	State of input terminal 1	Display	1
Bit4	Output current	Display	1	Bit12	State of input terminal 2	Not display	0
Bit5	Output frequency	Display	1	Bit13	State of input terminal 3	Not display	0
Bit6	Current floor	Not display	0	Bit14	State of output terminal 1	Display	1
Bit7	Current position	Not display	0	Bit15	State of output terminal 2	Not display	0

The setting binary number is 010010000110111, the corresponding algorithm number is 18487, and FA-01 should be set as 18487. These displaying parameter can be switched by shift key in control keyboard.

FA-02	Stop display	Default	65535	Min. Unit	1
	Setting Range	0~65535			

This function code is made up of binary numbers with 16 bit that displays 12 kinds of stopping state parameters. The displaying parameters can be switched by shift key on the control keyboard in the following list. The setting way is the same with FA-01.

Bit0	Rated speed	Bit6	System state
Bit1	Bus voltage	Bit7	State of input terminal 1
Bit2	Current floor	Bit8	State of input terminal 2
Bit3	Current position	Bit9	State of input terminal 3
Bit4	Car load	Bit10	State of output terminal 1
Bit5	Rated lift's decelerate distance	Bit11	State of output terminal 2

The stopping and running parameters are useful and important reference for the technician when adjusting the lift. The specific meaning of each variable is described as follows:

Running speed: is the actual speed when the lift is running. It's the feedback speed of rotation encoder whose maximum value is the fasted speed (F0-03) of the lift, with the unit m/s.

Setting speed: is the speed of NICE1000 when it's running. It's gained by the theoretical calculations with the unit m/s.

Bus voltage: is the value of DC bus voltage with the unit V.

Output voltage: is the valid value of equivalent voltage when NICE1000 outputs PWM wave form, with the unit V.

Output current: is the valid value of the actual current when NICE1000 drive motor is running, with the unit A.

Output frequency: is the actual frequency when the motor is running with the unit Hz. This parameter is fixed corresponding with the running speed.

Current floor: the information for physic floor where the lift stays when it's running. Its content is the same with F4-01.

Current position: It reflects the absolute position of the car to the leveling plate of the first floor. The unit is M.

Car load: according to the information from the sensor, it's the percentage of car load to rated load, with the unit %.

Pre-torque current: It reflects the percentage of compensational pre-torque current to the rated current when the lift is starting, with the unit %.

State of input terminal 1: It shows the meaning of the terminals by bit. If the bit is "1", the signal is valid. There is 16 bit whose meanings are as follows:

Binary bit	Meaning	Binary bit	Meaning
Bit0	Reserved	Bit8	Closed door output feedback signal
Bit1	Leveling 1 signal	Bit9	Inspection signal
Bit2	Leveling 2 signal	Bit10	Inspection up signal
Bit3	Door zone signal	Bit11	Inspection down signal
Bit4	Run output feedback signal	Bit12	Once fire signal
Bit5	Brake output feedback 1 signal	Bit13	Reserved
Bit6	Brake output feedback 2 signal	Bit14	Lock lift signal
Bit7	U.V.W jump out feedback signal	Bit15	Up limit signal

State of input terminal 2: It shows the meaning of the terminals by bit. If the bit is "1", the signal is valid. There is 16 bit whose meanings are as follows:

Binary bit	Meaning	Binary bit	Meaning
Bit0	Down limit signal	Bit8	Door 1 close limit signal
Bit1	Up force reducer signal	Bit9	Door 2 close limit signal
Bit2	Down force reducer signal	Bit10	Door 1 light curtain signal
Bit3	Over load signal	Bit11	Door 2 light curtain signal
Bit4	Full load signal	Bit12	Motorman signal
Bit5	Urgent stop (safety feedback) signal	Bit13	Direct arrival signal
Bit6	Door 1 open limit signal	Bit14	Direction changing signal
Bit7	Door 2 open limit signal	Bit15	Independent running signal

State of input terminal 3: It shows the meaning of the terminals by bit. If the bit is "1", the signal is valid. There is 16 bit whose meanings are as follows:

Binary bit	Meaning	Binary bit	Meaning
Bit0	Door 2 selection signal	Bit8	Reserved
Bit1	UPS input availability	Bit9	Safety circuit signal(AC 110V signal)
Bit2	Open button	Bit10	Door lock circuit 1 signal(AC 110V signal)
Bit3	Close button	Bit11	Door lock circuit 2 signal (AC 110V signal)
Bit4	Safety circuit(DC 24V signal)	Bit12	Reserved
Bit5	Door lock circuit 1(DC 24v signal)	Bit13	Reserved
Bit6	Door lock circuit 2(DC 24V signal)	Bit14	Reserved
Bit7	Half-load signal	Bit15	Reserved

State of output terminal 1: It shows the meaning of the terminals by bit. If the bit is "1", the signal is valid. There is 16 bit whose meanings are as follows:

Binary bit	Meaning	Binary bit	Meaning
Bit0	Y0 output	Bit8	Door2 open output
Bit1	Running contactor output	Bit9	Door2 close output
Bit2	Brake contactor output	Bit10	Low 7 segment code a display output
Bit3	Brake forced output	Bit11	Low 7 segment code b display output
Bit4	Illumination and fan output	Bit12	Low 7 segment code c display output
Bit5	Synchronous motor U.V.W jump out output	Bit13	Low 7 segment code d display output
Bit6	Door1 open output	Bit14	Low 7 segment code e display output
Bit7	Door1 close output	Bit15	Low 7 segment code f display output

State of output terminal 2: It shows the meaning of the terminals by bit. If the bit is "1", the signal is valid. There is 16 bit whose meanings are as follows:

Binary bit	Meaning	Binary bit	Meaning
Bit0	Low 7 segment code g display output	Bit8	Full load output
Bit1	Up arrowhead display output	Bit9	Inspection output
Bit2	Down arrowhead display output	Bit10	Illumination and fan Output 2
Bit3	Minus display output	Bit11	Door lock jump out contactor output
Bit4	Fire to main landing signal output	Bit12	BCD, Gray code. 7 block code high bit output
Bit5	Buzzer control output	Bit13	Integrated running normal output
Bit6	Over load output	Bit14	Reserved
Bit7	Arrival gong output	Bit15	Reserved

System state: It shows the meaning by bit. If the bit is "1", the signal is valid. There is 16 bit whose meanings are as follows:

Binary bit	Meaning	Binary bit	Meaning
Bit0	System light curtain state 1	Bit8	Car state: 1: door open; 2: door open keeping; 3: door close 4: door open arrival 5: running
Bit1	System light curtain state 2	Bit9	
Bit2	Lock lift	Bit10	
Bit3	Fire	Bit11	
Bit4	Lift state: 0: inspection; 1:well	Bit12	
Bit5	self-learning; 3:fire arrival main floor;	Bit13	System over load
Bit6	4:firemen; 6: motorman ;	Bit14	Reserved

Binary bit	Meaning	Binary bit	Meaning
Bit7	7:normal	Bit15	Reserved

FA-03	Pulse wheel encoder currently angle	Default	0.0°	Min. Unit	0.1°
	Setting Range	0.0~360.0°			

It displays the synchronous motor's current factual angle of the encoder. User cannot modify it.

Function code	Name	Setting Range	Default	Min. Unit
FA-04	Software version (ZK) 2	0~65535	0	1
FA-05	Software version (DSP) 3	0~65535	0	1
FA-06	Radiator temperature	0~100℃	0	1℃

It displays the software edition NICE1000 is using. FA-06 displays radiator's current temperature.

6.12 Group FB Door Function Parameters

FB-00	door machine number	Default	1	Min. Unit	1
	Setting Range	1~2			

It can set the number of door machine. User can set this function parameter by actual using number of door machine.

FB-01	Open-through door selection	Default	1	Min. Unit	1
	Setting Range	0~3			

The function can only be valid when the selection of FB-00 is 2.

0: Open-through door synchronous control (Open door, close door, call, button displays are totally the same.)

1: Call consistency, manual control open-through door (Door1 call and door 2 call are coincident, when arriving the destination, if both two doors can

operate, the switch of door1 and door 2 is controlled by the car button.)

2: Call independent, manual control open-through door (Door1 responds to door1's external call; door2 responds to door2's external call. When it arrives to the destination, if both two doors can operate, the switch of door1 and door 2 is controlled by the car button.)

3: Call independent, automatically control open-through door (In this condition, there must be two operation boxes separately corresponding to two doors. Door1 responds to door1's external call; door2 responds to door2's external call. When it arrives to the destination, if both two doors can operate, the switch of door1 and door2 is determined by their operation boxes.)

Details are listed in chapter 7.

FB-02	Door machine 1 service floor	Default	1023	Min. Unit	1
	Setting Range	0~1023(set 1~10 floor)			

This function code is made up of binary numbers with 10 emic that control those floors allowing door1 to open normally within floor 1 to floor 10. Every floor door is controlled by one binary number.

1: Relevant floor's front door can be open.

0: Forbidden relevant floor's front door open.

Its setting way is the same with F6-05; details are shown in section 6.7.

Notice: this parameter shouldn't clash with F6-05 when user's setting! It's required to ensure that door machine's service floor is the system service floor.

FB- 03	Hand-pull door open arrival delay time	Default	5	1s
	Setting range	1-60s		

This function is valid when the hand-pull door function is active

FB-04	Door2 service floor	Default	1023	Min. Unit	1
	Setting Range	0~1023(set 1~10 floor)			

This function code is made up of binary numbers with 10 emic that control those floors allowing door2 to open normally within floor 1 to floor 10. Every floor door is controlled by one binary number.

1: Relevant floor’s back door can be open.

0: Forbidden relevant floor’s back door open.

Its setting way is the same with F6-05; details are shown in section 6.7. The function parameter can only be valid when the door number of FB-00 is 2.

FB-05	Back -leveling landing delay	Default	0.00	Min. unit	0.01
	Setting range	0.00-2.00			

FB-06	Open door time protection	Default	10s	Min. Unit	1s
	Setting Range	5~99s			
FB-08	Close door time protection	Default	15s	Min. Unit	1s
	Setting Range	5~99s			
FB-09	Door open/close times	Default	0	Min. Unit	1
	Setting Range	0~20			

The open/close door time protection means: When the system outputs open/close door command but doesn’t receive open/close door arrival feedback after the time of FB-06 and FB-08, the door machine turns to close/open door at once. This is once for door open and close. When it reaches the times FB-09 (open/close door times) setting of open/close door, the system will warn E48 door open error or E 49 door close error.

If FB=09=0, the open/close protection is invalid. The system will repeat the open(close) action.

FB-07	Program control selection	Default	0	Min. unit	1
-------	---------------------------	---------	---	-----------	---

	Setting range	Bit 0 reserved Bit 1 reserved Bit 2 reserved Bit 3 reserved Bit 4 landing 300MS current bias valid Bit 5 reserved Bit 6 reserved Bit 7 reserved Bit 8 no "close" output after close arrival just judge lock circuit 1 Bit 9 reserved Bit 10 no "close" output when close arrival (no lock judgment) delay 1s Bit 11 no "open " output when after open arrival and delay 1s Bit 12 reserved Bit 13 high/low voltage 1.5s inspection Bit 14 reserved Bit 15 reserved
--	---------------	---

Applications of some special function:

No "close door" output after close door arrival (no judgment of lock) delay 1s

When FE-14 set to 1(no "close door "output after close door arrival) and also FB-07 BIT 10 set as 1,the lift close door arrival and delay for 1s then stop close output(no judgment about lock)

Attention: Only when set FE-14 BIT as 1,and the lift close arrival (lock is active),stop close door output

No "open door "output after open door arrival, delay 1s

When FE-14 bit 1 set as 0: the function of open door arrival and hold opening is invalid. When set FB-07 as 1,the lift open door arrival and delay for 1s,then stop open signal output

High/low voltage 1.5s inspection: if (safety, lock 1, lock 2) high voltage and low voltage input signal's interval time longer than 1.5s,the input signal

output pre-warning signal.

Function code	Name	Setting Range	Default	Min. Unit
FC-04	The 1st error information	0~3199	0	1
FC-05	The 2nd error information	0~3199	0	1
FC-06	The 3rd error information	0~3199	0	1
FC-07	The 4th error information	0~3199	0	1
FC-08	The 5th error information	0~3199	0	1
FC-09	The latest error information	0~3199	0	1
FC-10	The latest error speed	0.000~3.000m/s	0.000	0.001m/s
FC-11	The latest error current	0.0~999.9A	0.0	0.1A
FC-12	The latest error bus voltage	0~999V	0	1V

This group function codes can note the latest 6 times error code. The error information is made up of 4 bit, the higher 2 bit mean the car stopping floor when error occurs, and the lower 2 bit mean error code. For example: If the latest error information noted by FC-09 is 0135, it means that the latest error code is Err35 and the latest error floor is the first floor. FC-10~FC-12 record the outputting current, bus voltage and the current running speed when the latest error happens. The error's type and meaning refers to chapter 8.

6.14 FD Group Reserved Parameters

6.15 FE Group Lift Function Setting Parameters

FE-00	collective selective mode	Default	0	Min. Unit	1
	Setting Range	0,1,2			

0: Full selective, lift responds to up call and down call.

1: Down selective, lift only responds to hall down call and doesn't respond to hall up call.

2: Up selective, lift only responds to hall up call and doesn't respond to hall down call.

Function code	Name	Setting Range	Min. Unit	Default
FE-01	Floor 1 corresponding display	0000~1999	1	1901
FE-02	Floor 2 corresponding display		1	1902
FE-03	Floor 3 corresponding display		1	1903
FE-04	Floor 4 corresponding display		1	1904
FE-05	Floor 5 corresponding display		1	1905
FE-06	Floor 6 corresponding display		1	1906
FE-07	Floor 7 corresponding display		1	1907
FE-08	Floor 8 corresponding display		1	1908
FE-09	Floor 9 corresponding display		1	1909
FE-10	Floor 10 corresponding display		1	0100

This group function code can set hall displaying content of the opposite floor. Its value is made up of 4 bit. The higher 2 bit express the tens digit of floor displaying, and the lower 2 bit express the first rank of floor displaying. The higher 2 bit's and lower 2 bit's meaning are as follows:

Code	Display	Code	Display
00	0	06	6
01	1	07	7
02	2	08	8
03	3	09	9
04	4	18	-
05	5	19	No display

For example:

Actual floor	Required displaying	Higher 2 bit setting	Lower 2 bit setting	Corresponding function code setting
Basement 1	-1	'-' corresponding code 18	'1' corresponding code 01	1801
Floor 1	1	No display, corresponding code 19	'1' corresponding code 01	1901
Floor 2	2	No display,	'2'	1902

Actual floor	Required displaying	Higher 2 bit setting	Lower 2 bit setting	Corresponding function code setting
		corresponding code 19	corresponding code 02	
Floor 3	3	No display, corresponding code 19	'3' corresponding code 03	1903

FE-12	External call output selection	Default	1	Min. Unit	1
	Setting Range	0~3			

0: 7 segment code

1: BCD code

2: Reserved

3: Binary bit code

It's set by the encoding way of external call display panel. The system default is BCD code. If select the 7 segment code, please set F7-14~F7-16 output as 7 segment code corresponding output.

FE-13	Lift factory function selection1	Default	33795	Min. Unit	1
	Setting Range	0~65535			
FE-14	Lift factory function selection2	Default	2080	Min. Unit	1
	Setting Range	0~65535			

These function codes set the lift factory required functions. Each function is controlled by one binary number,"1" expresses this function allowable,"0" expresses this function forbidden.

The keyboard operation of F3-13 and FE-14 is by the bit which is different from that of other function codes. These two parameters divide the digital tube into two parts. The first part is two digital tubes in the left indicating the current displaying bit, and the second part is a digital tube in the right indicating the value of the current displaying bit. Two tubes in the middle is

meaningless and no displaying. Press the right-moving key >> to choose the fourth or the fifth bit digital tube. Press the up or down key to change the bit needs checking or modifying. The first digital tube displays the current bit's state as 0 or 1 with the change of the bit. Meanwhile, press the right-moving key to the first bit digital tube, and press up or down key to change the state as 0 or 1. Then press Enter key to store current state to the current bit. Each changing of a bit needs storing, and after the storing, it will display the state of following bit as a default. Press down key when it displays the state of the first bit, or press up key or Enter key when it displays the state of the fifteenth bit, both operations will display the value of the function parameter.

The function of each bit of FE-13 is listed as follows:

Binary bit	Function	Binary bit	Function
Bit0	Reserved	Bit8	Manual control the opposite door in Inspection/ATT state
Bit1	Attendant do not response to the hall call	Bit9	Independent running
Bit2	Re-leveling	Bit10	Inspection automatically close the door
Bit3	Reserved	Bit11	Current floor call open
Bit4	Reserved	Bit12	Reserved
Bit5	reserved	Bit13	Emergency self slide running function
Bit6	Open in non-door zone when inspecting	Bit14	Emergency self-rescue overtime protection
Bit7	Open once after inspection become normal	Bit15	Door lock short wiring examine function

The function of each bit of FE-14 is listed as follows:

Binary bit	Function	Binary bit	Function
Bit0	Fast brake check	Bit8	N.C output of synchronous motor U,V,W jump out contactor

Binary bit	Function	Binary bit	Function
Bit1	Open door to the right position, keep open	Bit9	Return leveling immediate stop
Bit2	No close door during running	Bit10	Reserved
Bit3	Hand-pull door selection	Bit11	No close door command when the lights in the car are off
Bit4	Automatic reset of contact conglutination	Bit12	Illumination and fan N.C. output
Bit5	Forced decelerate switch conglutination test	Bit13	Fire back base floor normal running no output
Bit6	Synchronous motor U,V,W jump out contactor stops to output	Bit14	Open time extension when no call
Bit7	Reserved	Bit15	Reserved

In order to make it convenient for lift factories to do the value added setting, several functions of NICE 1000 is chosen through FE-13, FE-14. The functions mentioned above are described as follows:

Attendant do not response to the hall call: the system do not response to the hall call in the ATT state, but inform the attendant by the inside floor lamp; no auto closing in ATT state.

Re-leveling: in the condition of high floor or heavy- load lift, the car will higher (or lower) than the sill because of the sudden change of load. The lift will re-leveling in low speed when door open after select this function.

Open in non-door zone : when inspection: when lift under inspection, the door can automatically open by open button after select this function

Open once after inspection become normal: the door will automatically open/close once after the inspection is over and state is normal in the door zone.

Manual control the opposite door in Inspection/ATT state : this function

can be realized by the front/back door switching button

Independent running: It gets into the independent running condition through the independent running switch in the car cage. At the moment, the lift doesn't respond to the hall call and the door operation is the same with that in motorman condition, which means there's no automatic door closing and it opens the door automatically if it fails to complete closing the door. If it's in the parallel state, the system will get off the parallel automatically.

Maintenance automatic close door: When the machine room is in the maintenance operation, if the car cage's door isn't closed, it will cause the lift's door lock block and the lift can't travel. If choose this function, press UP and DOWN button, the lift will close the door automatically when it's in maintenance. There's no close door signal outputting if you don't press UP and DOWN button.

Current floor inside call open function: the inside call can re-open the door in the normal state.

Emergency self slide running: While it uses permanent-magnet synchronous motor, the lift can fulfill self slide running through the U,V,W jump-out contactor when there's power failure and it opens the door when it slides to the leveling position. This function enables the economical emergency rescue realize.

Emergency self-rescue overtime protection: If the car cage is in balance load or the rescue driving power's capacity is not adequate, it will cause long emergency rescue time and even dangers occur. This function enables to stop rescuing when self slide running rescue time is over 100s, and rescue driving time is over 50s.

Door lock short wiring examine function: If door lock jump-out is found after door open arrival, the system alarms E53 when the lift is running in normal condition.

Open door to the right position, keep open: If choose this function, the lift keep outputting open door signal when there's door opening arrival.

Close door to the right position, no output door closing: If choose this function, the lift doesn't output close door signal when it is running or close door to the right position.

Contactors conglutination recover automatically: Detect the brake, and

traveling contactors' feedback contacts, alarm E36, E37 if the contacts are deviant, and it can't recover automatically. If the two errors occur, this function enables to recover automatically no more than three times as long as these errors disappear.

Force reducer switch conglutination inspection: This function enables to monitor the force reducer switch all the time when the lift is running. If conglutination is detected, it's forced to deceleration.

Open extension button when close the door : the door can be re-open by open extension button when closing the door.

Brake off delay when no running command after starting

Return leveling immediate stop: immediate stop when receive the door zone signal in return leveling state

Synchronous motor enclosed star contactor outputs when it stops: Synchronous motor KFX can assure that there won't be fast speed slide running even when the brake doesn't work. Under this function, NICE 1000 output terminal selection 05 (synchronous motor U,V,W jump-out output) can output in self-motion when the lift stops. If choose the feedback contact input (some function codes set as 07 or 107 in function codes F5-01~F5-24), NICE 1000 will monitor the KFX feedback contact in the application of synchronous motor, and alarm E29 if anything deviant occur.

N.C. of synchronous motor KFX: In synchronous motor, synchronous motor KFX control usually adapt N.C. switch.

P.S. KFX stands for the U,V,W jump-out contactor

No close door command when the lights in the car are off: It stops outputting close door command when the lights in the car are off.

Fire back to base floor normal running no output: the lift normal function off when fire back to the base floor.

Open time extension when no call: the system will keep open as set extension time when no call command.

6.16 Group FE Factory Parameters (Reserved)

6.17 Group FP User Parameters

FP-00	User password	Default	0	Min. Unit	1
	Setting Range	0~65535			

Set any number but zero, the password protection function is valid.

00000: Clear the password value setting by previous user, and make the password protection function invalid.

After the user password is set and become valid, when it gets into the parameter setting state, you can't check or modify the parameters if the password is not correct. Details of password setting measures are listed in chapter 4.

Please firmly remember your setting password, and contact with the factory if you miss-set or forget.

FP-01	Parameter resetting	Default	0	Min. Unit	1
	Setting Range	0,1,2			

0: None;

1: Return to factory parameters. All the values of other function parameters but motor parameter, floor parameter and error record parameter, will return to factory parameters. Please operate with caution!

2: Clear memory parameter. It will clear all the recorded error information.



Typical system application & adjusting

Chapter Typical system application & adjusting

7.1 Elevator adjusting



When the lift is in adjusting state, please keep smooth in shaft, and pay attention to the safety of workers.

In order to be convenient for adjusting, this chapter was written according to the normal sequence of lift adjustment. When the periphery circuit and machine installed are finished completely, you can finish the elevator's basic adjustment.

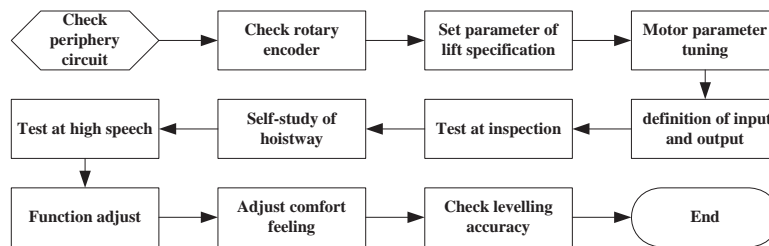

Fig. 7-1 adjusting process

7.2 System typical application

7.2.1 Full selection typical application

- 1) Terminal connection sketch of main door control board and setting parameters

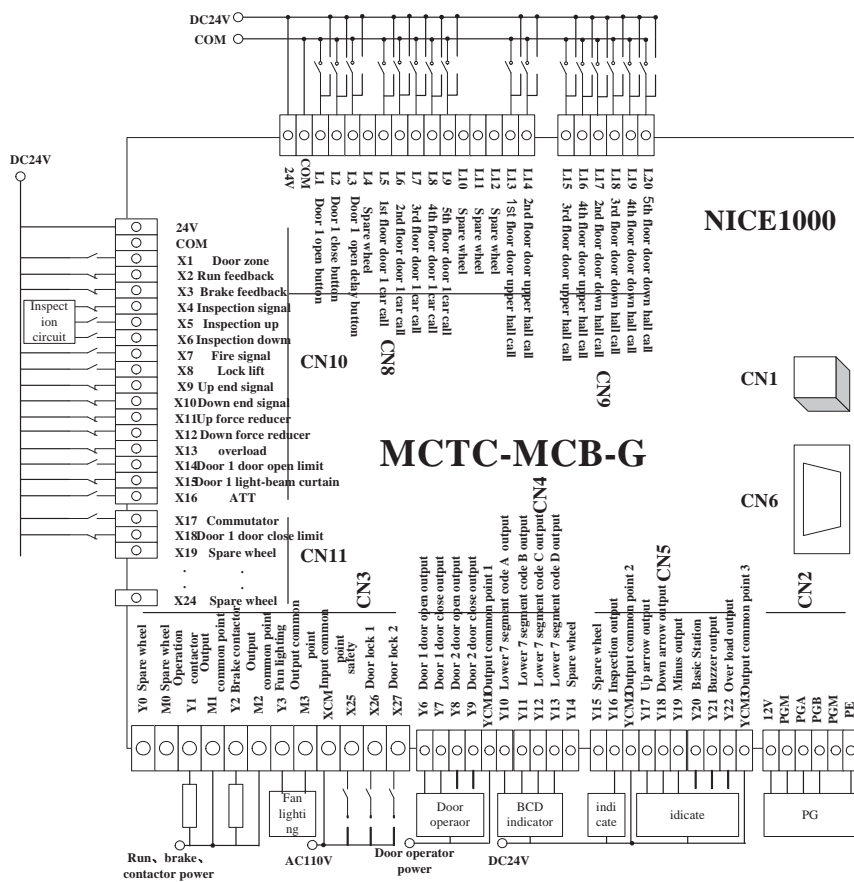

Fig. 7-2 Main control board terminal connection sketch

According to the connection mode of above graph, the terminal input/output and floor input /output are default parameters.

7.2.2 Up selection typical application

- 1) Terminal connection sketch of main control board and setting parameter.

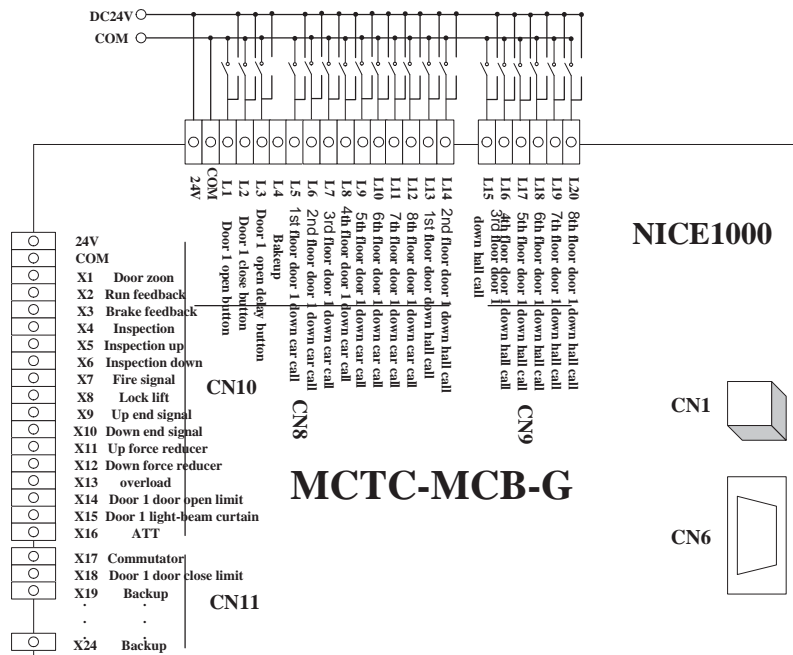

Fig. 7-3 Up selection terminal connection sketch

When the NICE adopts to up selection, it can get to the eighth floor if having no expansion board, or it can get to tenth floor with it. The above graph is an example which doesn't have expansion board. Button input and output connection is accordant to figure 7-2. It mostly changes the input/output connection floor button. You can revise the corresponding function code according to the very requirement, and detailed information is listed below.

Function code	default	modified	Function code	default	modified
F6-15	211	211	F6-23	221	221
F6-16	212	212	F6-24	222	232
F6-17	213	213	F6-25	223	233
F6-18	214	214	F6-26	224	234
F6-19	215	215	F6-27	232	235
F6-20	00	216	F6-28	233	236
F6-21	00	217	F6-29	234	237
F6-22	00	218	F6-30	235	238
FE-00	0	1	F6-00	5	8

User can reduce the button input/output terminal connection by the actual floor NO. It is valid when the door operator NO. is 2.

7.2.3 Open-through door typical application

- 1) Open-through door recommending connection drawing of main control board and relevant parameter setting.

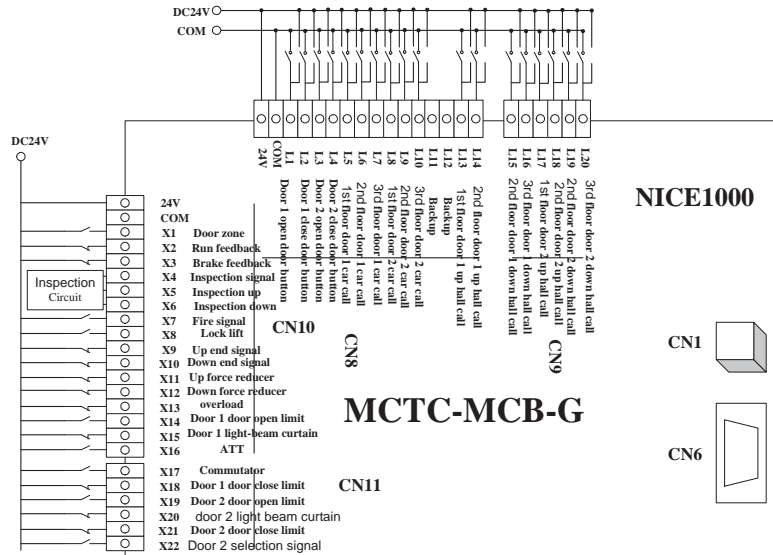

Fig. 7-4 Open-through door commended connection sketch

7-4 is an example of open-through door application which doesn't have expansion board, and the max floor is 3, with 2 doors on each floor. The part of input switch and output connection is the same to figure 7-2. The most change is part of input switch adds door 2 open door limit, door 2 light beam curtain, door 2 close door limit and door 2 selection signal. Door 2 hall's door lock and car's door lock are connected to corresponding door 1 hall's door lock and car's door lock, and it is connected to input terminal of main control board. You can revise the corresponding function code according to the very requirement, and detailed information is listed below.

Function code	Default	Modified	Function code	Default	Modified
F5-19	00	23	F5-21	00	125
F5-20	00	127	F5-22	00	32
F6-13	00	301	F6-23	221	221
F6-14	00	302	F6-24	222	222
F6-15	211	211	F6-25	223	232
F6-16	212	212	F6-26	224	233
F6-17	213	213	F6-27	232	321
F6-18	214	311	F6-28	233	322

Function code	Default	Modified	Function code	Default	Modified
F6-19	215	312	F6-29	234	332
F6-20	00	313	F6-30	235	333
F6-00	5	3			
FB-00	1	2	FB-01	0	1, 2

Users can add floor button input and output connection by reducing the number of open-through doors. It only can be used when there are two mainframes.

2) Setting the function selection of the open-through door

NICE1000 open-through door's function contains 3 kinds of practice-model, get set via FB-01.

FB-01	Meanings	Instruction of wire connection
0	The operation of open-through door is consistent. All the response is the same. It contains internal call, external call open the door. Close the door about Door 1 and Door 2. Open-close door's operation is the same too.	The calling button or the open-close door button of Door 1 and Door 2 in the same floor can be joined, and it connects to the input-output terminal in the same floor. And it could increase the running max floor.
1	The response of Door 1 and Door 2 call is the same. After getting to the destination floor, system would select opening which door by input state of Door 2 selects signal. If input high level signal, the lift would open the Door 2, contrarily, the lift will open the Door 1. This signal would connect to the car's button, and the people inside the car will control it.	The external calling button or the open-close door button of Door 1 and Door 2 in the same floor can be joined, and it connects to the input-output terminal in the same floor. And it could increase the running max floor. If you choose this way, the x-input terminal needs to select the Door 2 selection-signal's function. Otherwise, the lift only can open the Door.
2	The response of Door 1 outside hall call is independence. After getting to the destination floor. System would select opening which the door by input state of Door 2 selects signal. If input high level	The external hall calling button of Door 1 or Door 2 in the same floor can connect to the input-output terminal in the different floors. If you choose this way, the X-input terminal

FB-01	Meanings	Instruction of wire connection
	signal, the lift would open the Door 2, contrarily, the lift will open the Door 1. This signal would connect to the car's button, and the people inside the car will control it.	needs to select the Door 2 selection-signal's button. Otherwise, the lift only can open Door 1.
3	The response of Door 1 and Door 2 outside hall call is independence. After getting to destination floor. System would automatically select opening which door by this response is Door 1 inside call of Door 2.	The external-car and internal-car's calling button of Door 1 and Door 2 should connect to the input-output terminal respectively in the different floors. Otherwise, the lift may open the Door 1 and Door 2 at the same time.

7.2.4 Power failure emergency running typical application

NICE1000 power failure emergency running contains 3 kinds of model:

Auto-slide :

It means that opening the brake, and the prevent-force limits the car's running by permanent-magnet synchronous motor jumps out stator coil. That is a rescue-way's which the car is running slowly to get to the level. After the Nice 1000 receives a power-failure-rescue signal, u should jump the U, V, W's wire of permanent-magnet synchronous motor, and open brake. The lift would auto-slide. During the process you should monitor the lift's speed, till leveling. When the speed is slowly.(The car is balance load or the load variation's number is small) u can close braking, and stop operation.

48V battery supply of power to run:

The main circuit of NICE1000 has adopted 48V battery supply of power. The power of other part would adopt UPS supply which is greater than 220V. Do it, the motor can run normally by store battery's power, and the work power's capacity will be small. After NICE1000 chooses the way which is power failure rescue, it would run with emergency speed (F8-09). The direction is the same to the running direction of lift light-load. Keep surveillance the speed of elevator in this period, and then output the passenger and stop running.

UPS supply of power:

Both the main circuit and work-power of Nice 1000 have adopted UPS power to power failure emergency run. After NICE1000 chooses the way of power failure rescue, it would run by emergency speed, the direction is the same to run direction of lift light-load run. When detecting signal, it will open the door and stop working.

You can see their characteristic via the following Fig.:

Mode	Motor power source	Working-power of NICE1000	Working-power of the lift's safety circuit	Range	Other
Auto-slide car	Permanent-magnet synchronous motor jumps stator coil	Using the UPS which is greater than 220V (or inverter)	Using the UPS which is greater than 220V (or inverter)	Permanent-magnet synchronous motor	Need self-locking contact or to jump out U,V,W
UPS supply of power	220V UPS applies of power	220V UPS applies of power	220V UPS applies of power	Permanent-magnet synchronous or asynchronous motor	
48V battery supply of power	48V store battery	Using the UPS which is greater than 220V(or inverter)	Using the UPS which is greater than 220V(or inverter)	Permanent-magnet synchronous or asynchronous motor	

We mainly introduce typical application of auto-running by the following Fig.. If use other way (include rescue automatically switch). You can contact with us MNK.

- 1) Self-slide emergency running sketch

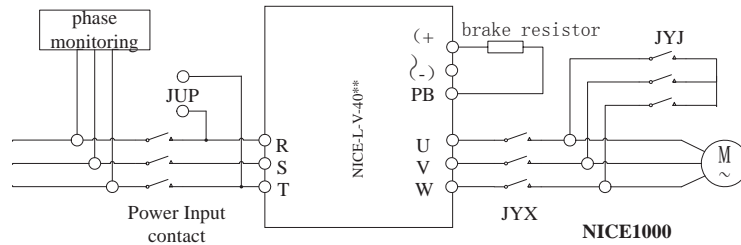

a) Main circuit wiring diagram

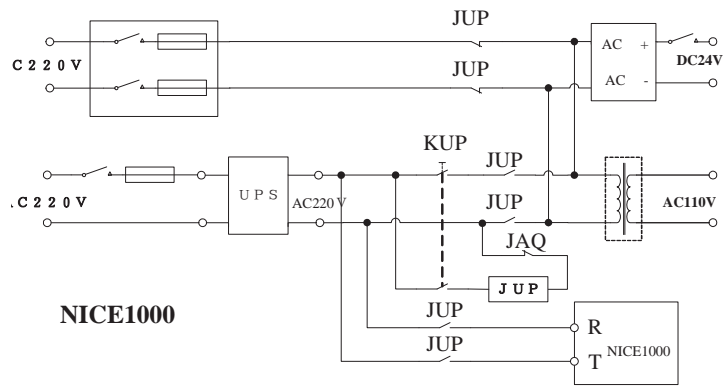

b) UPS power circuit diagram

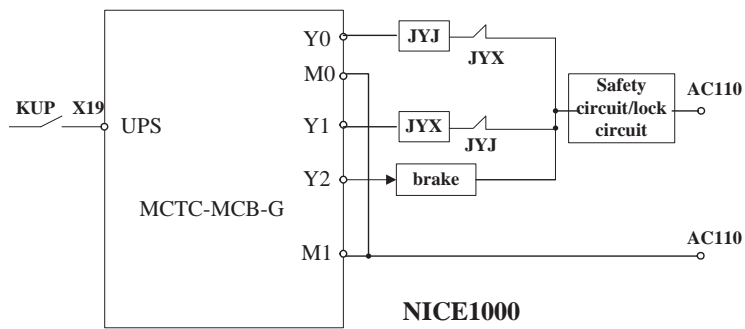

Fig. 7-5 power failure emergency system

c) main control board wiring diagram

Instruction of above graph: 1)-3), JYX is the output wiring contactor; JYJ is the star-closure contactor of synchronous motor; JUP is power failure rescue run manual switch; JAQ is safety signal. In this case, UPS will supply power to door operation, safety circuit, brake and so on.

2) Instruction of power failure emergency run

a) Time sequence diagram

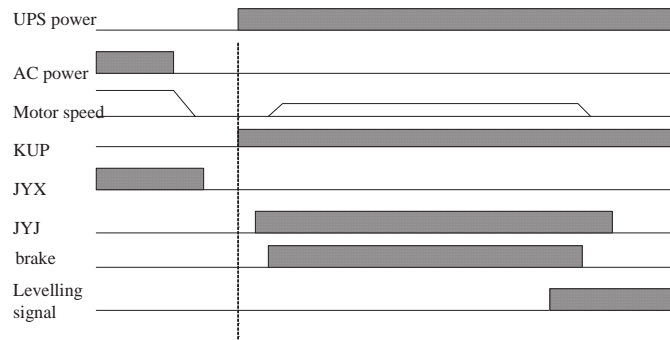

Fig. 7-6 self-running time sequence

b) Function code setting

According to 7-5 wiring diagram, the NICE1000 auto-slide power failure emergency run need set the following parameter:

Function code	Default	Modified	Function code	Default	modified
F5-19	00	33	F7-00	00	32
FE-13	33792	41984 Bit13 is set 1			

c) Attention items

- During the auto-slide, the NICE1000 can't control the motor drive, the power of life auto-running is come from self-supply power of synchronous motor;
- During the auto-slide, if the lift's speed is more than 1/2 rated speed, the NICE1000 will adopt alarm protect (E33), don't be controlled by auto-running, and at the same time the jump contactor of synchronous motor maybe get abnormality;

- This way is only applied to synchronous motor, and never be applied to asynchronous motor, otherwise, it will be very dangerous;
 - This way need some gap between load in the car and load of lift balance; otherwise, the lift run-speed will be slow.
- d) Manual switching way

Normality, the KUP should have disconnected. When the UPS is charging, the system's power comes from main power supply. When the main power is cut, user can control system emergency by KUP, and the KUP is close, UPS power is supplied to system power. When NICE1000 receives the UPS input signal, and make sure the mode is power failure emergency run, close Y0, then open brake, the lift will auto-running; at the same time monitor lift speed, till leveling.

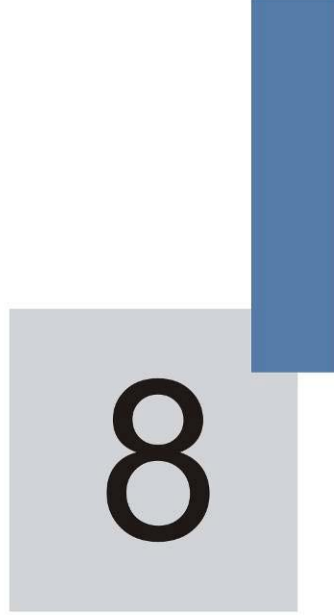

Faults – Causes - Remedies

Chapter 8 Faults – Causes - Remedies

8.1 Fault Classification

The system controller has almost 60 pieces of alarm information or protection functions. NICE1000 monitors all kinds of input signal, running condition, exterior feedback information. If some abnormal error happens, relevant fault protection functions will act and the system controller will display the fault code.

Error information produced by NICE1000 can be divided into 5 sorts according to their influence to the system. Different fault has different disposal mode. And the respective relationship is listed as the following table:

Fault sort	Relevant disposal	Remark
Level 1	Display fault code	Any kind of working condition will not be influenced.
Level 2	Display fault code; Sever lift group control (parallel) system;	Can operate normal running.
Level 3	Display fault code; Stop at the nearest landing when in distance control, then stop running; Stop running at once in other work condition.	After stop, the system will close off output at once, and close brake.
Level 4	Display fault code; When in distance control, the system will close off output at once and close brake; after stop, low speed running (such as return leveling, inspection) is allowed.	The elevator can run in low speed in condition of fault code.
Level 5 fault	Express fault code;	Running forbidden.

Fault sort	Relevant disposal	Remark
	The system blank off output at once, and close brake; Running forbidden	

8.2 Fault details & Remedies

If fault alarm information appears, the system will dispose by their fault code. At this time, user can analyze fault on basis of suggestive information in this chapter, to spy fault cause, and find out remedies

Operate panel display	Digital tube display	Fault description	Probable cause	Remedy	Sort
Err01	E01	Invert unit protection	1.Main circuit output is grounding or short wiring; 2.The connection of traction machine is too long; 3.Work condition is too hot; 4.The connections inside the controller become loose;	1.Obviate exterior problems such as connection; 2.Add reactor or output filter; 3.Inspect the wind channel and fan; 4.Please contact with agent or factory;	5
Err02	E02	Accelerated over-current	1.Main circuit output is grounding or short wiring; 2.If the motor has done parameter tuning of not; 3.Load is too heavy;	1.Obviate exterior problems such as connection; 2.Motor parameter tuning; 3.Lighten sudden adding load;	5
Err03	E03	Decelerated over-	1.Main circuit output is grounding or short	1.Obviate exterior problems such as	5

Operate panel display	Digital tube display	Fault description	Probable cause	Remedy	Sort
		current	wiring; 2.If the motor has done parameter tuning of not; 3.Load is too heavy; 4.Decelerate curve is too steep;	connection; 2.Motor parameter tuning; 3.Lighten sudden adding load; 4.Adjust the curve parameter;	
Err04	E04	Constant speed over-current	1.Main circuit output is grounding or short wiring; 2.If the motor has done parameter tuning of not; 3.Load is too heavy; 4.Pulse wheel encoder interference is too strong;	1.Obviate exterior problems such as connection; 2.Motor parameter tuning; 3.Lighten sudden adding load; 4.Select proper encoder, and adopt shielded cable;	5
Err05	E05	Accelerated over-voltage	1.Input voltage is too high; 2.Lift inverse pull is serious; 3.Brake resistance is too much, or brake unit is abnormal; 4.Accelerate curve is too steep;	1.Adjust input voltage; 2.Adjust the elevator startup time sequence; 3.Select proper brake resistance; 4.Adjust curve parameter;	5
Err06	E06	Deceleration over-volt	1.Input voltage is too high;	1.Adjust input voltage; 2.Select proper brake	5

Operate panel display	Digital tube display	Fault description	Probable cause	Remedy	Sort
		age	2.Brake resistance is too much, or brake unit is abnormal; 3.Accelerate curve is too steep;	resistance; 3.Adjust curve parameter;	
Err07	E07	Constant speed over-voltage	1.Input voltage is too high; 2.Brake resistance is too much, or brake unit is abnormal;	1.Adjust input voltage; 2.Select proper brake resistance;	5
Err08	E08	Controller power fault	1.Input voltage is too high; 2.Drive control panel is abnormal;	1.Adjust input voltage; 2.Please contact with agent or factory;	3
Err09	E09	Under-voltage fault	1.Transient power cut exists; 2.Input voltage is too low; 3.Drive control panel is abnormal;	1.Obviate exterior problem of power; 2.Please contact with agent or factory;	5
Err 10	E10	System overload	1.Brake circuit is abnormal; 2.Load is too heavy;	1.Inspect brake loop and power supply; 1.Lighten load;	4
Err 11	E11	Motor overload	1.FC-02 setting is unsuitable; 2.Brake loop is abnormal; 3.Load is too heavy;	1.Adjust parameter; 2.Inspect brake loop and power supply;	3

Operate panel display	Digital tube display	Fault description	Probable cause	Remedy	Sort
Err 12	E12	Input side phase failure	1.Input power asymmetry; 2.Diver control panel is abnormal;	1.Adjust input power; 2.Please contact with agent or factory;	4
Err 13	E13	Output side phase failure	1.The connections of main circuit output become loose; 2.Motor is broken;	1.Inspect connection; 2.Obviate motor fault;	4
Err 14	E14	Module overheat	1.The temperature of working environment is too high; 2.The fan is broken; 3.The wind channel is blocked;	1.Reduce the environmental temperature; 2.Clear the wind channel; 3.Change the fan;	5
Err 17	E17	Contacto r fault	1.Bus voltage is abnormal; 2.Drive control panel is abnormal;	Please contact with agent or factory;	5
Err 18	E18	Current detection fault	Diver control panel is abnormal;	Please contact with agent or factory;	5
Err 19	E19	Motor tuning fault	1.Motor parameter setting is wrong; 2.Parameter tuning is overtime; 3.Synchronous rotate encoder is abnormal;	1.Input the right motor parameter; 2.Detect motor lead wire; 3.Detect the rotate encoder wiring, and make sure the pulse number per round is	5

Operate panel display	Digital tube display	Fault description	Probable cause	Remedy	Sort
				well set.	
Err 20	E20	Rotary encoder fault	1.Rotary encoder model is suited or not; 2.Encoder connection error;	1 .Asynchronous motor can select push-pull output or open-collector encoders; synchronous motor can select UVW or SIN/COS. 2.Obviate connection problem;	5
Err 21	E21	Synchronous encoder wiring fault	Error occurs to the wiring of synchronous encoder;	Please detect the wiring;	5
Err 22	E22	Leveling and door area signal conglutination fault	Leveling/door area signal is conglutination or cut off;	Please detect the leveling/door area inductor and main control panel input point.	1
Err 23	E23	Short circuit fault to ground	Output short circuit to ground;	Please contact with agent or factory;	5
Err 25	E25	Stored data abnormality	The stored data of main control panel is abnormal;	Please contact with agent or factory;	5

Operate panel display	Digital tube display	Fault description	Probable cause	Remedy	Sort
Err 29	E29	Synchronous U,V,W jump out contactor feedback abnormality	The feedback of synchronous U,V,W jump out contactor is abnormal;	Detect relevant wiring;	5
Err 30	E30	Elevator position abnormality	<ol style="list-style-type: none"> 1.Encoder feedback position deviation when lift is automatic running; 2.Levelling signal is cut or conglutinate when lift is automatic running; 3.Steel wire skid or motor locked-rotor; 	<ol style="list-style-type: none"> 1.Detect leveling inductor and flashboard; 2.Detect leveling signal wire connecting; 3.Ensure encoder is used right; 	4
Err 33	E33	Lift speed abnormality	<ol style="list-style-type: none"> 1.Actual speed is 15% over the highest running speed; 2.Low speed running is 20% over the setting speed; 3. Inspection switch acts when lift automatic running; 	<ol style="list-style-type: none"> 1.Ensure encoder is used right; 2.Detect motor nameplate parameter setting; 3.Retune motor; 4.Detect the inspection switch and signal wire; 	4

Operate panel display	Digital tube display	Fault description	Probable cause	Remedy	Sort
Err 34	E34	Logic fault	The control panel redundancy judge, logic fault.	Please contact with agent or factory to replace control panel.	5
Err 35	E35	Shaft self-tuning data abnormality	1.The startup place is not the lowest floor; 2.Continuous run time is more than 45 seconds without signal input; 3.The interval of floors is too short; 4.The highest metrical floor is different with the setting value; 5.The floor pulse record is abnormal; 6.When in self-tuning, the system is not in examine state;	1.Ensure up/down force reducer switch and signal; 2.Detect leveling inductor and flashboard setting; 3.Detect leveling signal wire connecting; 4.Make sure that the system is in examining state. 5.Carry through shaft self-tuning again when lift reaches the lowest floor;	4
Err 36	E36	Contact feedback abnormality	1.Running contactor is not pulled in when the brake is open; 2.When lift continuously runs over 1 second, the contact feedback signal is lost;	1.Detect contactor and feedback contact; 2.Detect that the controller output wire U,V,W is natural or not; 3.Detect that the circuit power of contact controlling is	5

Operate panel display	Digital tube display	Fault description	Probable cause	Remedy	Sort
			<p>3.The contactor feedback signal conglutinates;</p> <p>4.No feedback signal after the contact closed;</p>	natural or not;	
Err 37	E37	Brake feedback abnormally	The brake output is not consistent with the feedback signal.	<p>1.Detect that the brake coil and feedback contact;</p> <p>2.Notarize the signal character of the feedback contact (N.O. or N.C.);</p> <p>3.Detect that the circuit power of brake coil controlling is natural or not;</p>	5
Err 38	E38	Controller rotary encode signal abnormally	<p>1.No input encode pulse when lift is automatic running;</p> <p>2.The direction of input encode signal is wrong when lift is automatic running;</p> <p>3.Set to open-loop (F0-00) when in distance control;</p>	<p>1.Ensure encoder using right;</p> <p>2.Replce encoder's A,B phase;</p> <p>3.Detect the setting of F0-00, and change to close-loop control;</p>	5
Err 40	E40	Lift run overtime	The setting time of lift running is up.	<p>1.Lift speed is too low or the floor is too high;</p> <p>2.The lift is used for a</p>	4

Operate panel display	Digital tube display	Fault description	Probable cause	Remedy	Sort
				long time and needs maintenance;	
Err 41	E41	Safety circuit off	The signal of safety circuit is cut.	1.Detect safety circuit, and look over its state; 2.Detect that exterior power supply is natural or not;	5
Err 42	E42	Door lock cut in running	The door lock feedback is cut when lift is running.	Detect that the door lock contact is natural or not.	5
Err 43	E43	Up limit signal off in running	The signal of up limit is cut when lift is up running.	Detect that the up limit switch contact is natural or not.	4
Err 44	E44	Down limit signal off in running	The signal of down limit is cut when lift is down running.	Detect that the down limit switch contact is natural or not.	4
Err 45	E45	Up/Down slowdown switch off	Up and down slowdown switch is cut at one time when the elevator stops.	1.Detect 1st up/down slowdown switch; 2. Ensure 1st up/down slowdown signal characteristic (N.O. or N.C.);	4
Err 46	E46	Re-leveling abnormality	1.The speed of re-leveling is over 0.1m/s; 2.Re-leveling	1.Detect the primary , secondary circuit connection of lock relay.	1

Operate panel display	Digital tube display	Fault description	Probable cause	Remedy	Sort
			<p>position is not in the leveling area;</p> <p>3.The door lock feedback is abnormal when in running.</p>	<p>2.Detect that the door lock feedback function is selected or not, and signal is natural or not;</p> <p>2.Ensure the rotary encoder is used right;</p>	
Err 47	E47	Door lock jump out contactor conglutination	Contactors are conglutinated when having advance open door and re-leveling.	Detect door lock jump out contactor	5
Err 48	E48	Door open fault	The door continuous non-arrival open times are over the setting value of FB-09.	<p>1.Detect that the door machine is working natural or not;</p> <p>2.Detect the car top control panel is right or not;</p>	5
Err 49	E49	Door close fault	The door continuous non-arrival close times are over the setting value of FB-09.	<p>1.Detect that the door machine is working natural or not;</p> <p>2.Detect that the car top control panel is right or not;</p>	5
Err 53	E53	Lock jump fault	When in automatic running state, the stop has no door lock cut process;	Detect the lock signal circuit.	4