



MD210 Quick Start Manual

Smart AC Drive

Version 1.1

Dated 14th OCT, 2013



CONTENTS

CHAPTER 1	PRODUCT INFORMATION	1
1.1	Designation	1
1.2	Nameplate	1
1.3	General Specifications	2
CHAPTER 2	WIRING	3
2.1	Typical Wiring.....	3
2.2	Terminals.....	5
CHAPTER 3	EASY SETUP.....	7
3.1	Logic Of Control	7
3.2	Step By Step Setup.....	9
CHAPTER 4	TROUBLESHOOTING	22
4.1	Faults And Solutions	22
4.2	Common Symptoms And Diagnostics	25
CHAPTER 5	FUNCTION CODE TABLE	26
5.1	General Function Codes	26
5.2	Monitoring Function Codes	42

CHAPTER 1 PRODUCT INFORMATION

1.1 Designation

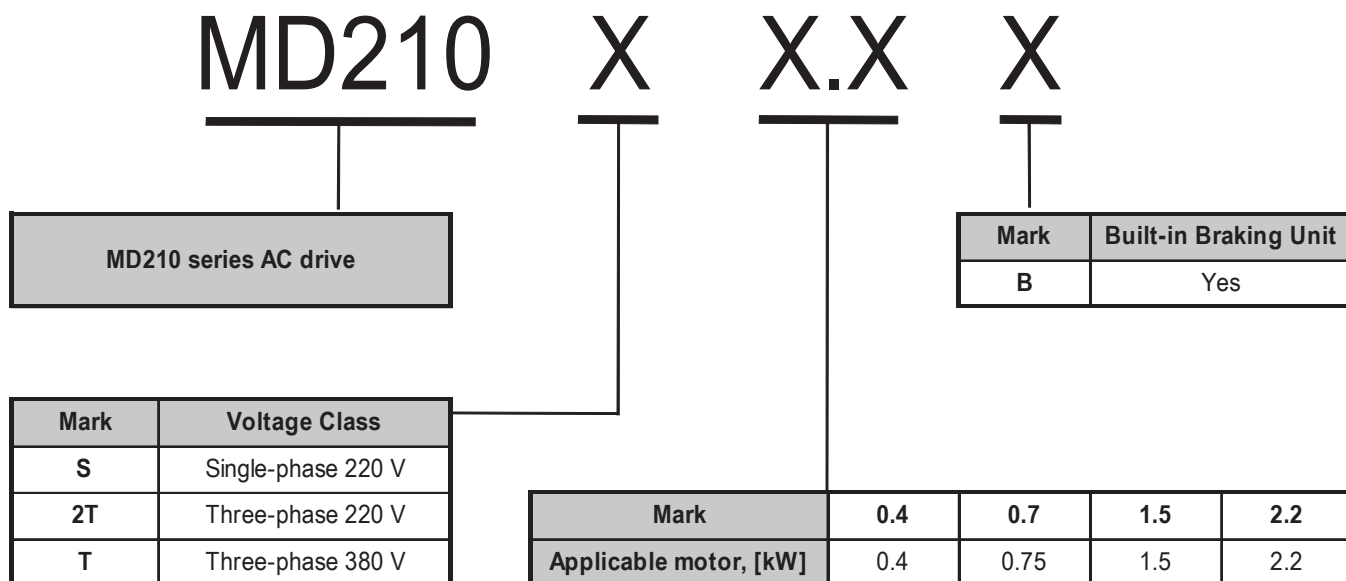

1.2 Nameplate

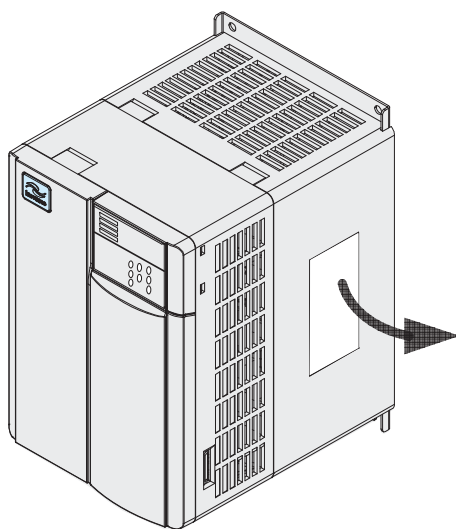

Nameplate	
AC drive model	MODEL: MD210T0.7B
Rated input	INPUT: 3~380-440V , 3.4A , 50/60Hz
Rated output	OUTPUT: 3~0-440V,2.1A,0-600Hz,0.75kW
S/N code	S/N: 013010024C700052
Barcode	
Manufacturer	Suzhou Inovance Technology Co.,Ltd.

1.3 General Specifications

Voltage Class		Single-phase 220V			Three-phase 220V			Three-phase 380V						
Drive Model		MD210 S0.4B	MD210 S0.7B	MD210 S1.5B	MD210 2T0.4B	MD210 2T0.7B	MD210 2T1.5B	MD210 T0.4B	MD210 T0.7B	MD210 T1.5B	MD210 T2.2B			
Frame Size		1 2		1 2		1 2								
Dimension★		H [mm]										128		
		W [mm]										108		
		148		158		148		158		148		158		
		D [mm]										148 158		
		A [mm]										96		
B [mm]										118				
Drive Input		Rated Input Voltage			Single-phase 220 VAC,-15 to 20% (187to 264 VAC)			Three-phase 220 VAC,-15 to 20% (187to 264 VAC)			Three-phase 380 to 440 VAC,-15 to 20% (323 to 528 VAC)			
		Rated Input Current(A)		5.4 8.2 14.0		3.4 5.0 5.8		1.9 3.4 5.0 5.8						
		Rated Input Frequency		50/60 Hz, ±5% (47.5 to 63 Hz)										
Drive Output		Applicable Motor		[kW]		0.4 0.75 1.5		0.4 0.75 1.5		0.4 0.75 1.5		2.2		
				[HP]		0.5 1 2		0.5 1 2		0.5 1 2		3		
		Output Current, [A]		2.3 4.0 7.0		2.1 3.8 5.1		1.5 2.1 3.8 5.1						
		Power Capacity, [kVA]		1.0 1.5 3.0		1.0 3.0 4.0		1.2 1.5 3.0 4.0						
		Overload Capacity★		120% for 1 hour & 150% for 60 Sec & 180% for 2 Sec										
		Max. Output Voltage		Three-phase 220 VAC (proportional to input voltage)			Three-phase 220 VAC (proportional to input voltage)			Three-phase 380 VAC (proportional to input voltage)				
		Max. Output Frequency		600Hz										
Recommended Braking Resistor		[kW]		≥0.08 ≥0.08 ≥0.1		≥0.15 ≥0.15 ≥0.25		≥0.15 ≥0.15 ≥0.15		≥0.25				
		[Ω]		≥200 ≥150 ≥100		≥150 ≥110 ≥100		≥300 ≥300 ≥220		≥200				
Cooling Method		Air Fan		Air Fan		Air Fan								

☆: At 6 kHz carrier frequency without derating

★: Dimensions are shown below:

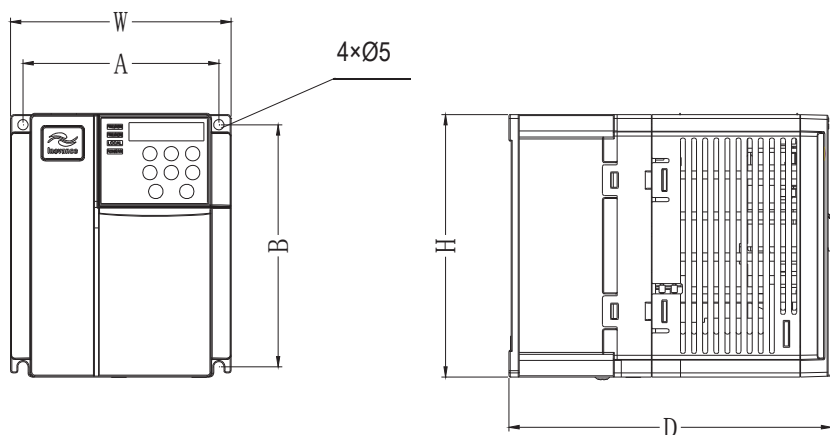

CHAPTER 2 WIRING

2.1 Typical Wiring

✓ Wiring Of Single-Phase 220 VAC(Keypad Control, F6-00=0)

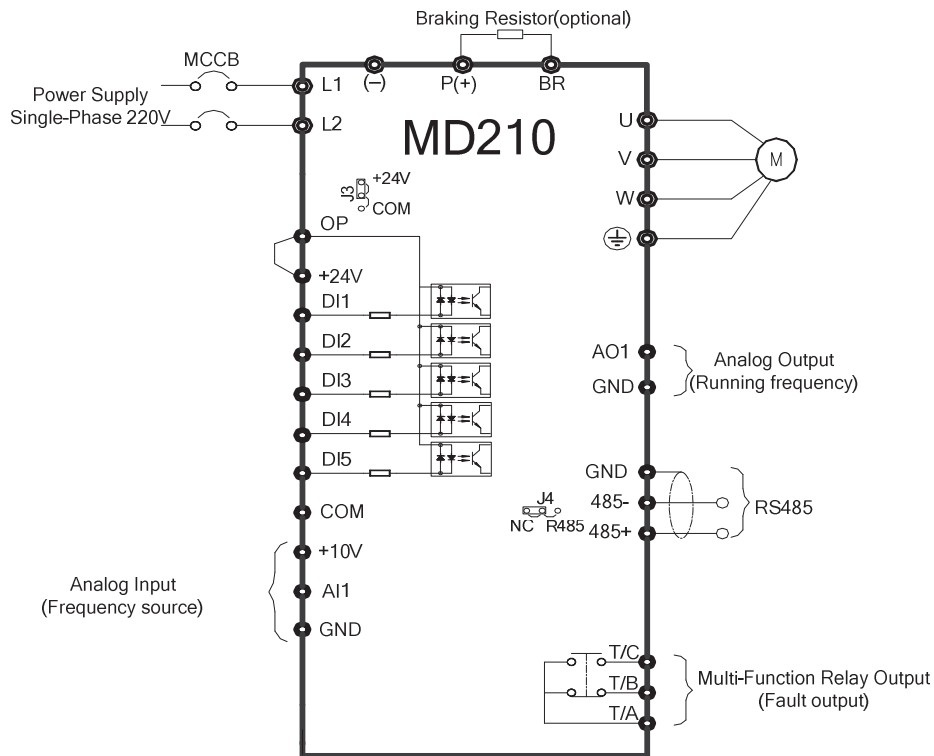

✓ Wiring Of Single-Phase 220 VAC(Terminal Control, F6-00=1)

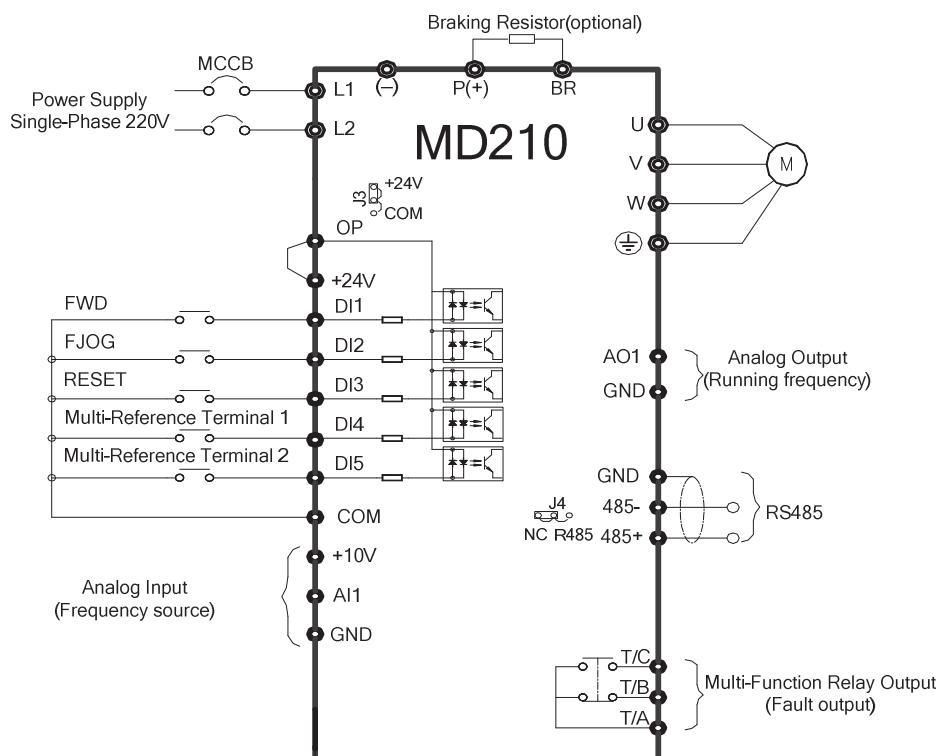

✓ **Wiring Of Three-Phase 220/380 VAC(Keypad Control, F6-00=0)**

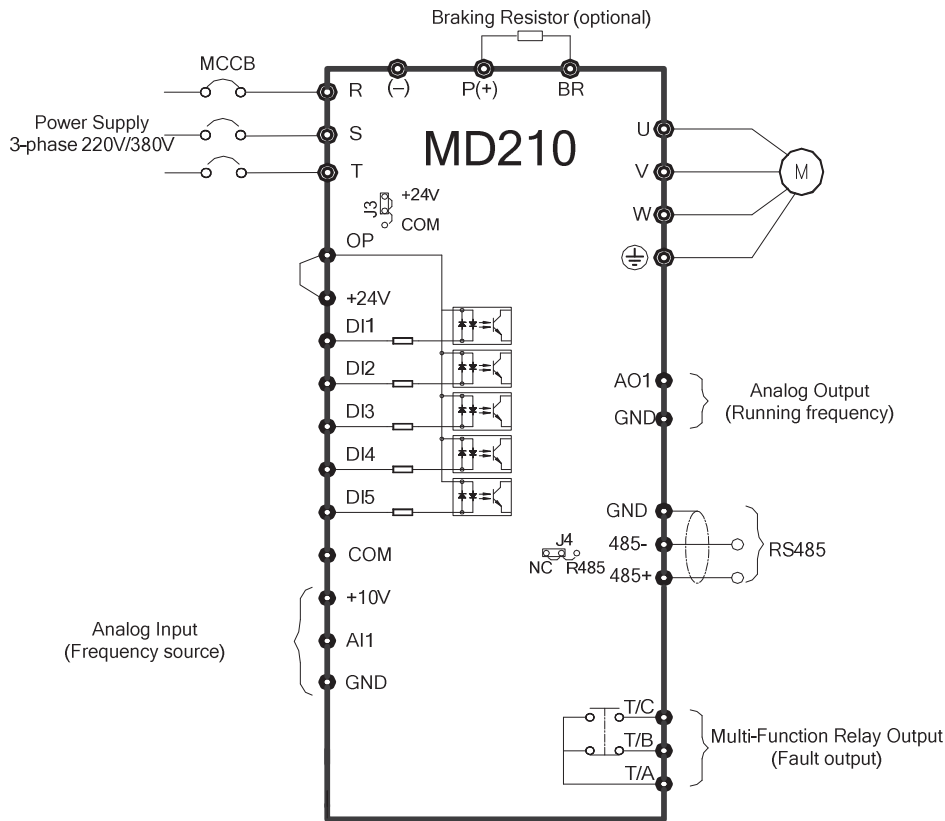

✓ **Wiring Of Three-Phase 220/380 VAC(Terminal Control, F6-00=1)**

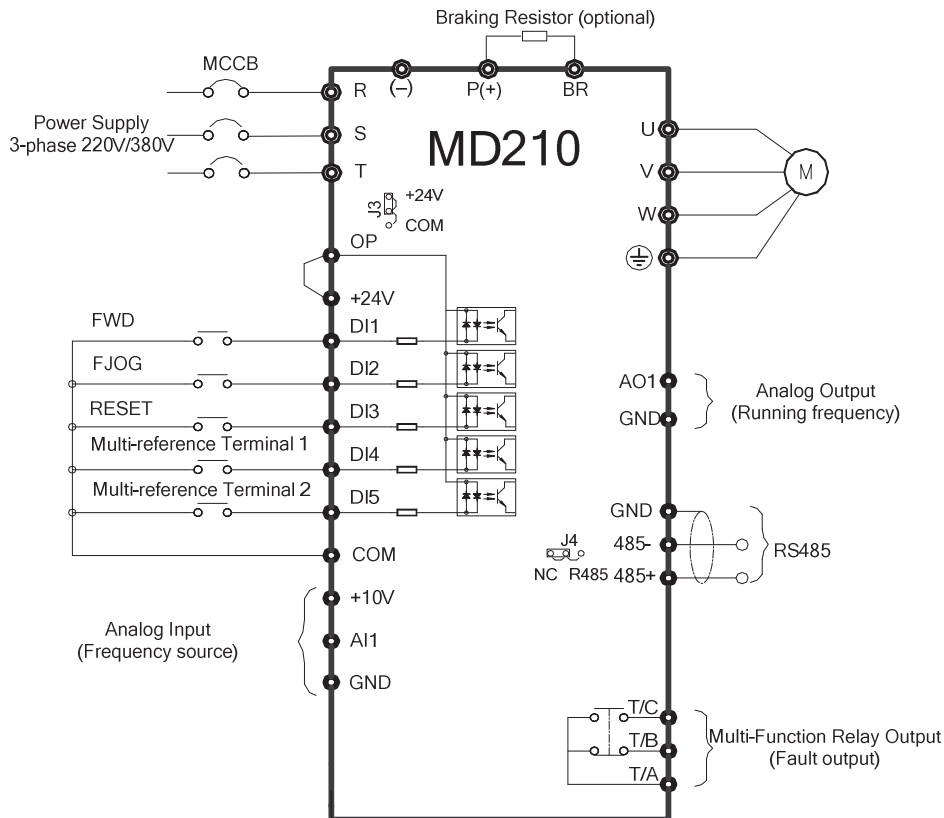

2.2 Terminals

✓ Terminals Of Main Circuit

Table 2-1: Main circuit terminals of the single-phase



Terminal	Terminal Name	Description
L1, L2	Single-phase power supply input terminals	Connect to the single-phase 220 VAC power supply.
P(+), (-)	Positive and negative terminals of DC bus	Common DC bus input point.
P(+), BR	Connecting terminals of braking resistor	Connect to a braking resistor.
U, V, W	AC drive output terminals	Connect to a three-phase motor.
	Grounding terminal	Must be grounded.

Table 2-2: Main circuit terminals of the three-phase

Terminal	Terminal Name	Description
R, S, T	3-phase power supply input terminals	Connect to the three-phase AC power supply
P(+), (-)	Positive and negative terminals of DC bus	Common DC bus input point;
P(+), BR	Connecting terminals of braking resistor	Connect to a braking resistor
U, V, W	AC drive output terminals	Connect to a three-phase motor.
	Grounding terminal	Must be grounded.

✓ Terminals Of Controlling Circuit

Terminal	Terminal Name	Description
+10V-GND	+10 VDC power supply	Provide +10 VDC power supply to external unit. Usually, it provides power supply to external potentiometer with resistance range of 1kΩ to 5kΩ; Maximum output current: 10mA
+24V-COM	+24 VDC power supply	Provide +24 VDC power supply to external unit. Usually, it provides power supply to DI/DO terminals and external sensors. Maximum output current: 200mA
OP	Input terminal of external power supply	Connect to +24 VDC by default. When DI1 to DI5 need to be driven by external signal, OP needs to be connected to external power supply and be disconnected from +24 VDC.
AI1-GND	Analog input 1	Input voltage range: -10VDC to 10 VDC Impedance: 22kΩ
DI1-COM	Digital input 1	Optical coupling isolation, compatible with dual-polarity input Impedance: 2.4kΩ Input voltage range: 9 to 30 VDC
DI2-COM	Digital input 2	
DI3-COM	Digital input 3	
DI4-COM	Digital input 4	
DI5-COM	High-speed pulse input	Besides features of DI1 to DI4, it can be used for high-speed pulse input. Maximum input frequency: 20 kHz
AO1-GND	Analog output 1	Output voltage range: 0 to 10 VDC
T/A-T/B	Normally closed terminal	Contact driving capacity: 250 VAC, 0.2A, COSφ=0.4 30 VDC, 1 A
T/A-T/C	Normally open terminal	

CHAPTER 3 EASY SETUP

3.1 Logic Of Control

✓ Complete Timing Diagram

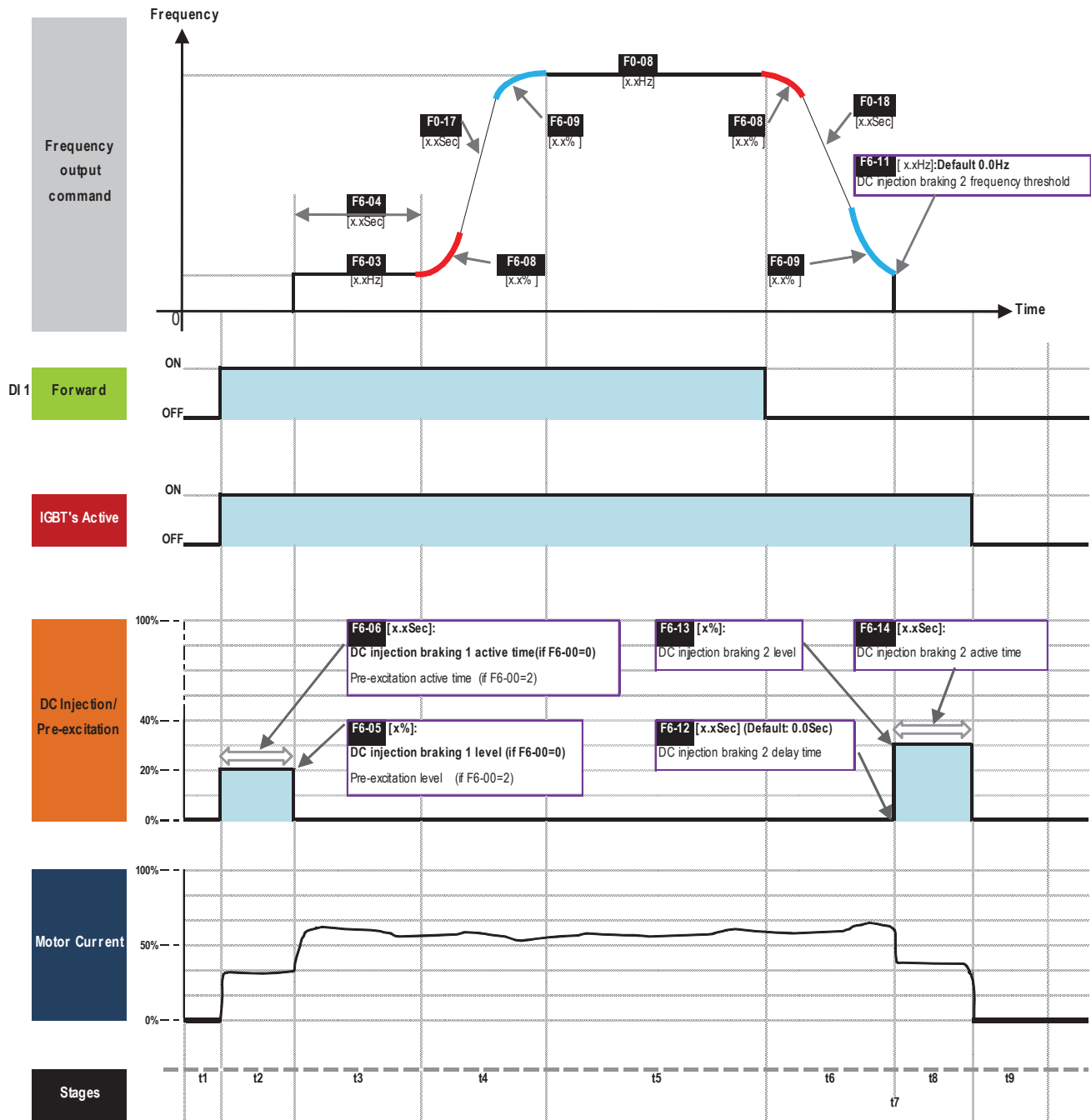

✓ Timing Diagram Description

Event	Description	Function code	Status
t1	-The AC drive waits for the RUN signal.	-----	Inhabit
t2	-The AC drive receives the Forward RUN command. -The IGBT becomes active. -DC Injection Braking 1/Pre-excitation is enabled if F6-06 > 0. (if F6-00 = 0, it is "DC Injection Braking 1"; if F6-00 = 2, it is "Pre-excitation")	----- ----- F6-05 F6-06	RUN
t3	-DC Injection Braking 1/Pre-excitation is disabled. -The startup frequency becomes active if F6-04 > 0.	----- F6-03 F6-04	RUN
t4	-The startup frequency becomes inactive. - The motor ramps up to the expected frequency. -S-curve active	----- F0-17 F6-08 F6-09	RUN
t5	-Motor runs at expected frequency.	F0-08	RUN
t6	-The Forward RUN command is cancelled. -The motor ramps down to zero frequency. -S-curve active	----- F0-18 F6-08 F6-09	RUN
t7	-The frequency output command reaches the DC Injection Braking 2 frequency threshold. -The IGBT shall become inactive if DC Injection Braking 2 delay time is not zero. -After the delay time set in F6-12, the IGBT becomes active again	F6-11 F6-12 -----	RUN (if F6-12 = 0) Inhabit (if F6-12 > 0)
t8	-DC Injection Braking 2 is enabled if F6-14 > 0	F6-13 F6-14	RUN
t9	-DC Injection Braking 2 is disabled. -The IGBT turns inactive.	----- -----	Inhabit

3.2 Step By Step Setup

✓ Setup Flowchart

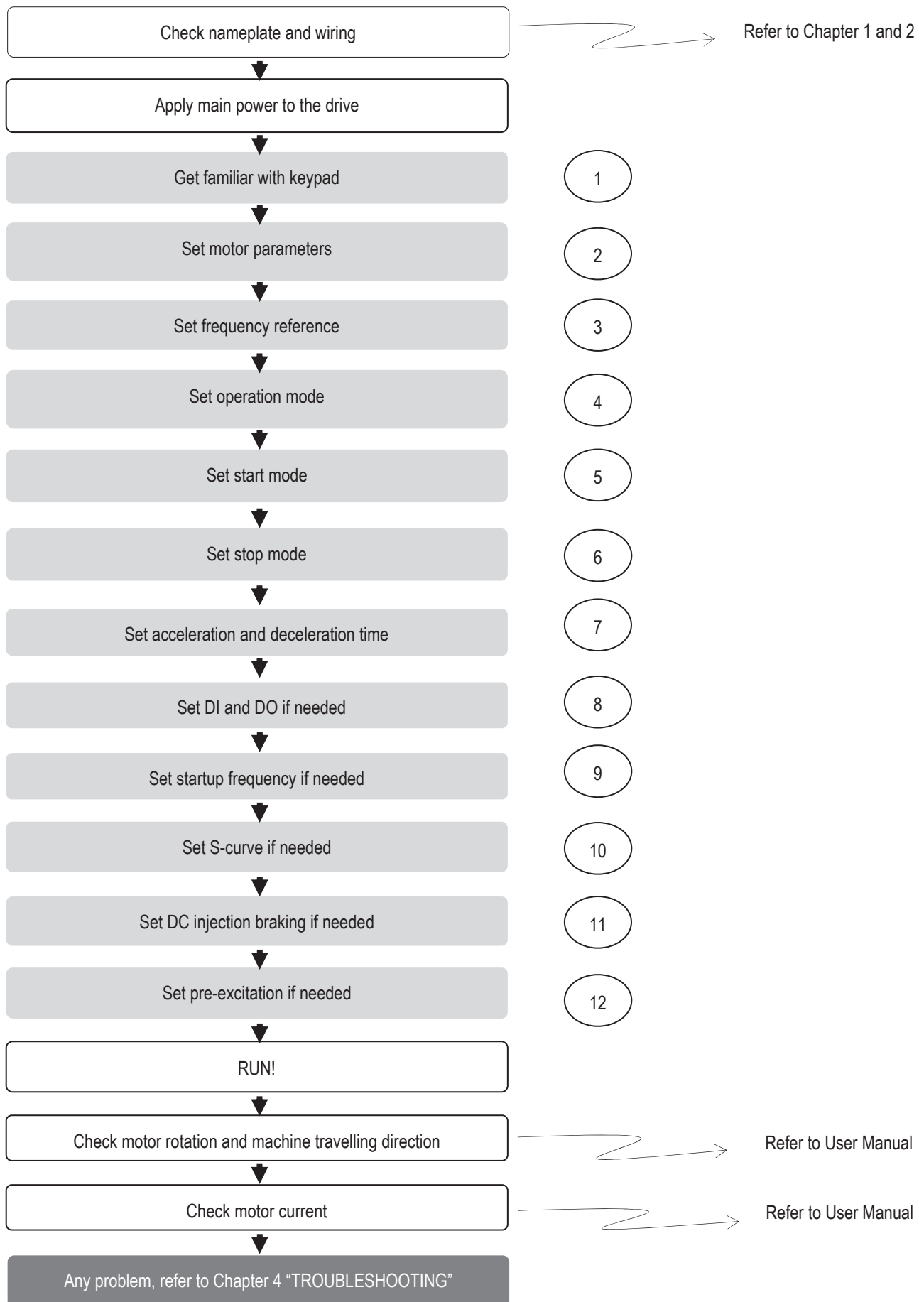

✓ Step 1: Get Familiar With Keypad

◆ Overview

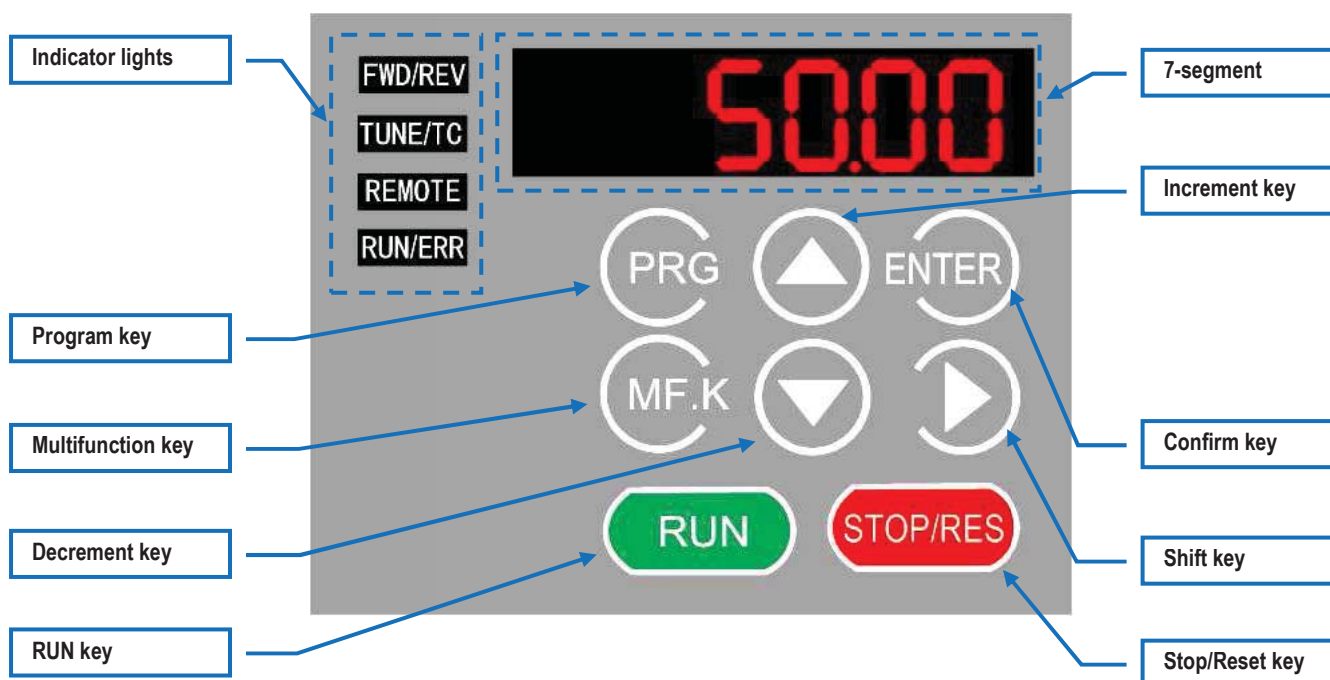

◆ Indicator Lights

FWD/REV : It indicates forward or reverse rotation.

OFF indicates forward rotation and ON indicates reverse rotation.

TUNE/TC : Reserved.

REMOTE : It indicates whether the AC drive is operated by means of keypad, terminals or communication.

OFF indicates keypad control, ON indicates terminal control, and blinking indicates communication control.









RUN/ERR : It indicates the state of the AC drive.

OFF indicates the stop state, ON (green) indicates the running state, and ON (red) indicates the faulty state.

◆ 7-Segment Display

5-digits LED display can be used to display reference frequency/output frequency, and kinds of monitoring data and alarming code.

◆ Keys On Keypad

Key	Key Name	Function
	Program	Enter or exit Level I menu.
	Confirm	Enter the menu interfaces level by level, and confirm the parameter setting.
	Increment	Increase data or function code.
	Decrement	Decrease data or function code.
	Shift	Select the displayed parameters in turn in the stop or running state, and select the digit to be modified when modifying parameters.
	RUN	Start the AC drive in the keypad operation mode.
	Stop/Reset	Stop the AC drive when it is in the running state and perform the reset operation when it is in the fault state. The functions of this key are restricted by F7-02 .
	Multifunction	Perform function switchover (such as quick switchover of command source or direction) according to the setting of F7-01 .

Function Code	Parameter Name	Setting Range	Unit	Default	Commission
F7-01	MF.K Key function selection	0: MF.K key disabled 1: Switchover between keypad operation and remote operation (terminal or communication) 2: Switchover between forward rotation and reverse rotation 3: Forward JOG 4: Reverse JOG 5: Parameter display	N.A	0	
F7-02	STOP/RESET key function	0: STOP/RESET key enabled only in keypad operation 1: STOP/RESET key enabled in any operation mode	N.A	1	

◆ Keypad Operation

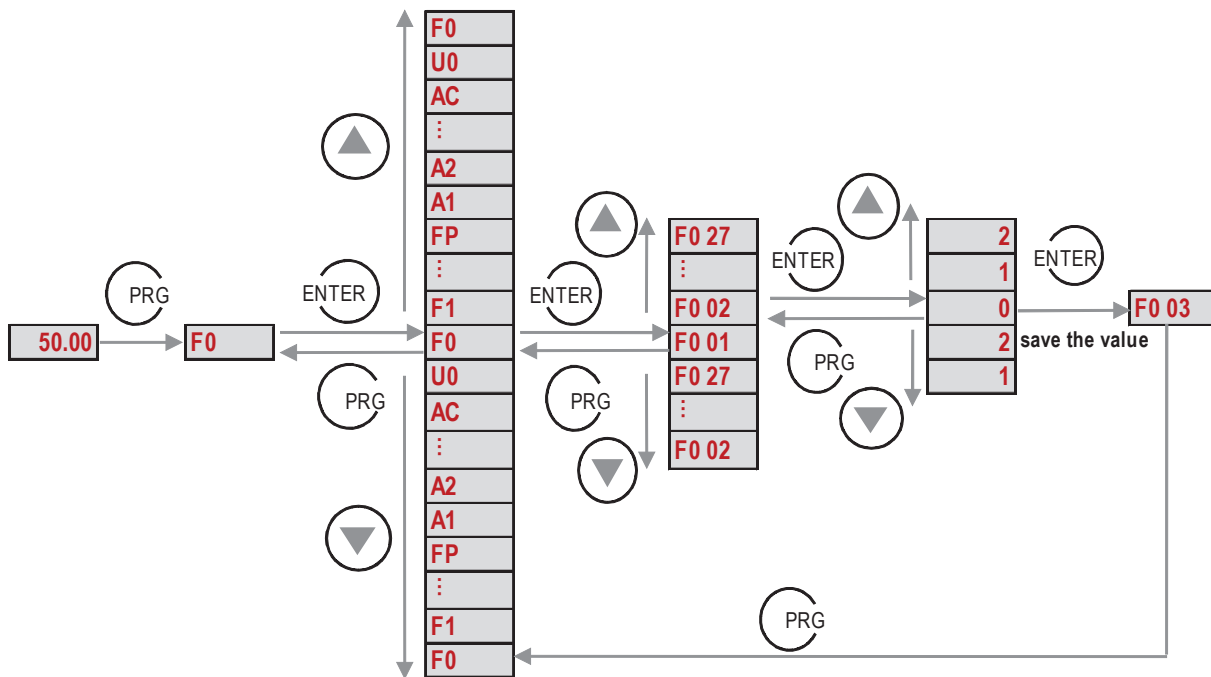

◆ Function Codes Arrangement

Function Code Group	Description	Remark
F0 to FP	Standard function code group	Compatible with MD380 series function codes
A1 to AC	Advanced function code group	All/AO correction
U0	Running state function code group	Display of basic parameters

✓ Step 2: Set Motor Parameters

Function Code	Parameter Name	Setting Range	Unit	Default	Commission
F1-00	Motor type	0: common asynchronous motor 1: variable-frequency asynchronous motor	N.A	0	
F1-01	Rated motor power	0.1 to 7.5	kW	Model dependent	
F1-02	Rated motor voltage	1 to 1000	V	Model dependent	
F1-03	Rated motor current	0.01 to 655.35	A	Model dependent	
F1-04	Rated motor frequency	0.01 to max frequency	Hz	Model dependent	
F1-05	Rated motor rotational speed	1 to 65535	RPM	Model dependent	

✓ Step 3: Set Frequency Reference

Function Code	Parameter Name	Setting Range	Unit	Default	Commission
F0-03	Main frequency source X selection	0: Digital setting F0-08 (non-retentive at power supply failure) 1: Digital setting F0-08 (retentive at power supply failure) 2: AI1 3: Reserved 4: Reserved 5: Pulse setting (DI5) 6: Multi-reference 7: Simple PLC 8: PID 9: Communication	N.A	0	
F0-04	Auxiliary frequency source Y selection	The same as F0-03 (Main frequency source X selection)	N.A	0	

Function Code	Parameter Name	Setting Range	Unit	Default	Commission
F0-07	frequency source selection	7-segment - - - 0 0	N.A	00	
	<p>0:X+Y 1: X-Y 2: the bigger one of X and Y 3: the smaller one of X and Y</p> <hr/> <p>0: Main frequency source X 1: X&Y 2: Switchover between X and Y (by DI terminal) 3: Switchover between X and "X & Y"(by DI terminal) 4: Switchover between Y and "X& Y"(by DI terminal)</p>				
F0-08	Preset frequency	0.00 to maximum frequency	Hz	50.00	

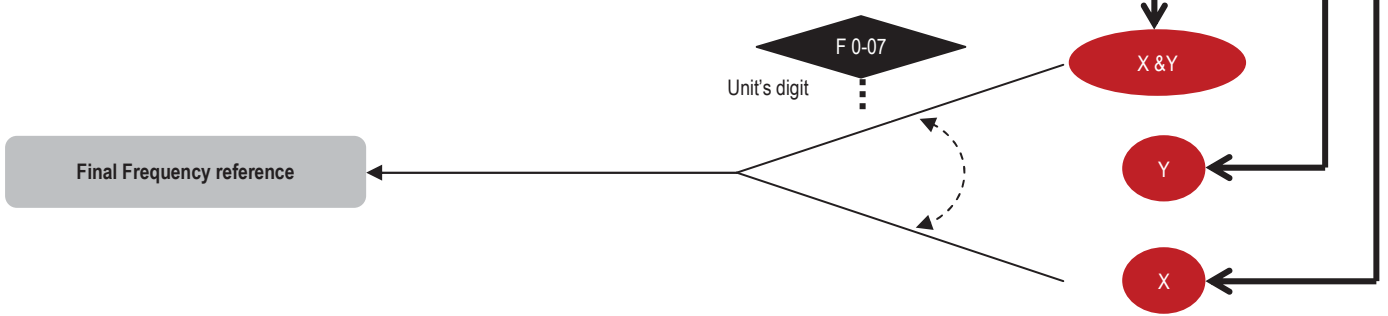
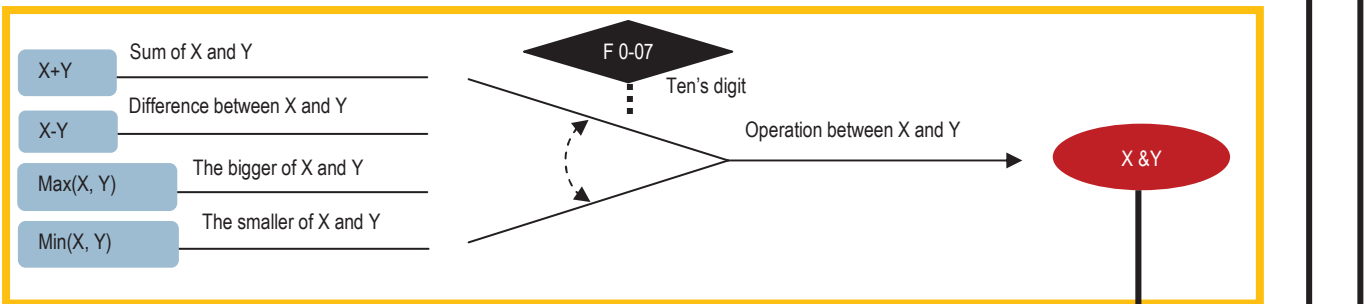
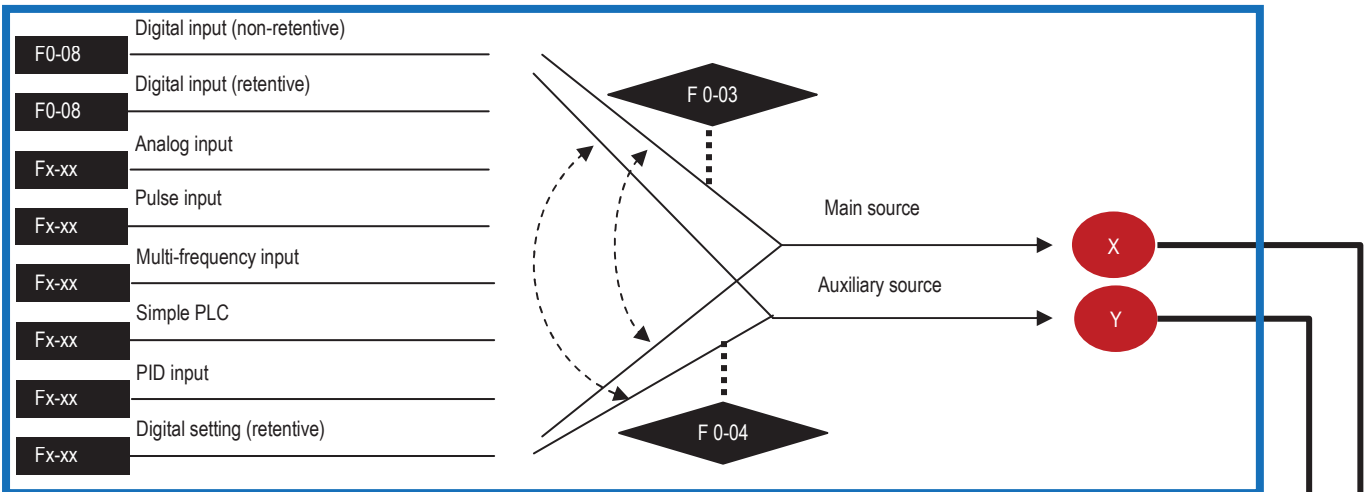

✓ Step 4: Select Operation Mode

Function Code	Parameter Name	Setting Range	Unit	Default	Commission
F0-02	Command source selection	0: Keypad control 1: Terminal control 2: Communication control	N.A	0	
F4-11	Terminal wiring mode selection	0: Two-wire mode 1 1: Two-wire mode 2 2: Three-wire mode 1 3: Three-wire mode 2	N.A	0	

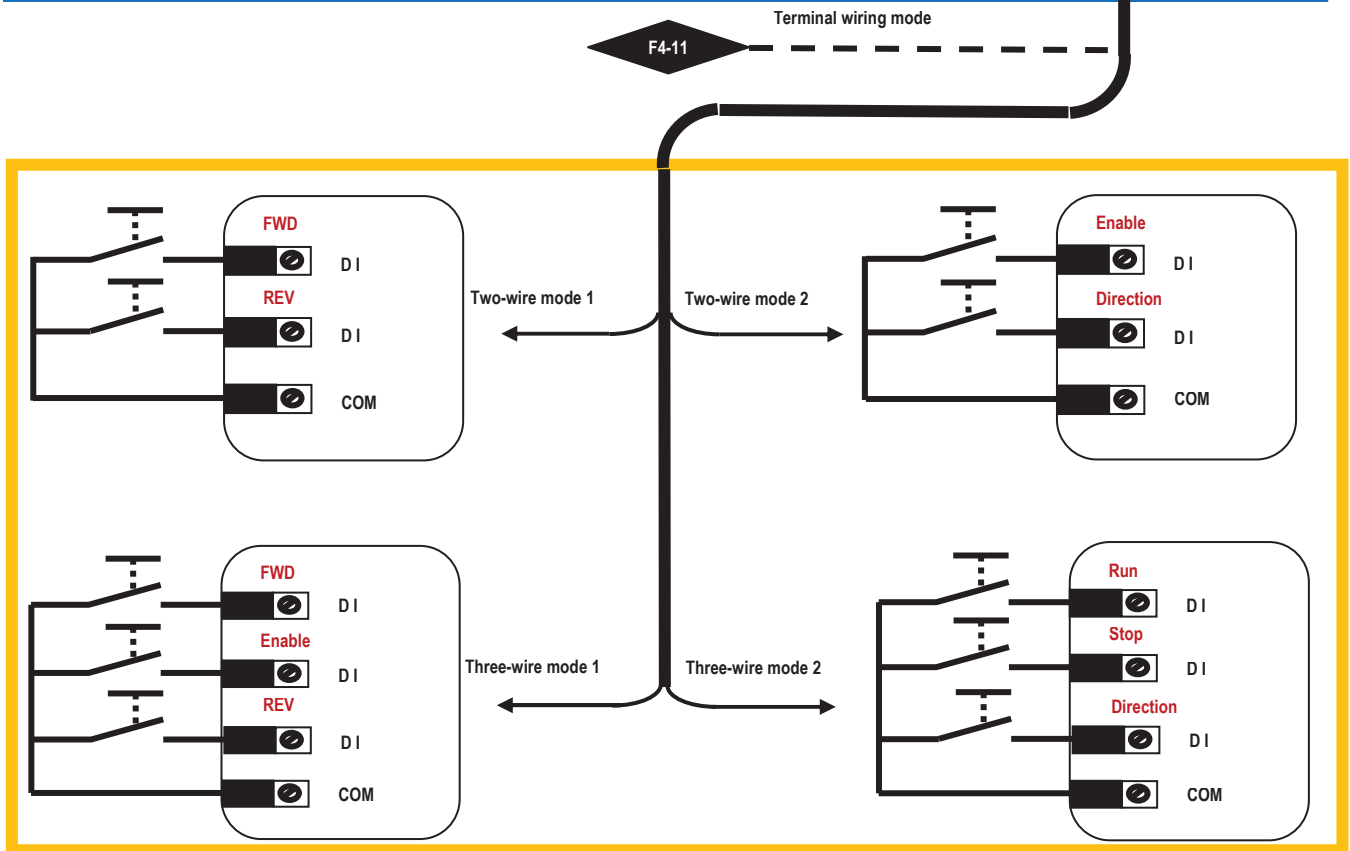
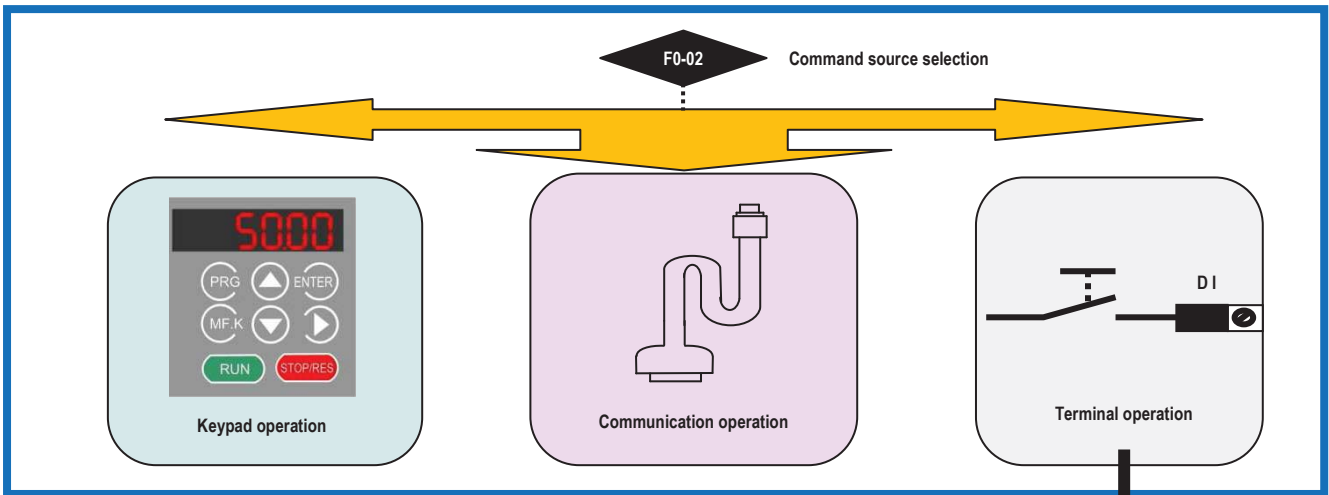

✓ **Step 5: Set Starting Mode**

Function Code	Parameter Name	Setting Range	Unit	Default	Commission
F6-00	Start mode	0: Direct start 1: reserved 2: Pre-excited start	N.A	0	

✓ **Step 6: Set Stopping Mode**

Function Code	Parameter Name	Setting Range	Unit	Default	Commission
F6-10	Stop mode	0: Decelerate to stop 1: Coast to stop	N.A	0	

✓ **Step 7: Set Acceleration And Deceleration Parameters**

Function Code	Parameter Name	Setting Range	Unit	Default	Commission
F0-17	Acceleration time 1	0.00 to 650.00 (if F0-19 = 2) 0.0 to 6500.0 (if F0-19 = 1) 0 to 65000 (if F0-19 = 0)	s	Model dependent	
F0-18	Deceleration time 1	0.00 to 650.00 (if F0-19 = 2) 0.0 to 6500.0 (if F0-19 = 1) 0 to 65000 (if F0-19 = 0)	s	Model dependent	
F0-19	Acceleration/ Deceleration time unit	0: 1s 1: 0.1s 2: 0.01s	N.A	1	
F6-07	Acceleration/ Deceleration mode	0: Linear mode 1: S-curve mode A 2: S-curve mode B	N.A	0	

✓ **Step 8: Set DI And DO If Needed**

◆ **DI Setting**

Function Code	Parameter Name	Setting Range	Unit	Default	Commission
F4-00	DI1 function selection	0: No function 1: Forward RUN (FWD)	N.A	1 FWD	
F4-01	DI2 function selection	2: Reverse RUN (REV) 3: Three-line control 4: Forward JOG (FJOG)	N.A	4 FJOG	
F4-02	DI3 function selection	5: Reverse JOG (RJOG) 6: Terminal UP	N.A	9 RESET	
F4-03	DI4 function selection	7: Terminal DOWN 8: Coast to stop 9: Fault reset (RESET)	N.A	12 Multi-reference terminal 1	
F4-04	DI5 function selection	10: RUN pause 11: Normally open (NO) input of external fault 12: Multi-reference terminal 1 13: Multi-reference terminal 2 14: Multi-reference terminal 3 15: Multi-reference terminal 4 16: Terminal 1 for acceleration/deceleration time selection 17: Terminal 2 for acceleration/deceleration time selection 18: Frequency source switchover 19: UP and DOWN setting clear (terminal, operation panel) 20: Command source switchover terminal 1 21: Acceleration/Deceleration prohibited 22: PID pause 23: PLC status reset 24: Swing pause 25: Counter input 26: Counter reset 27: Length count input 28: Length reset 29: Torque control prohibited 30: Pulse input (enabled only for DI5) 31: Reserved 32: Immediate DC braking 33: Normally closed (NC) input of external fault 34: Frequency modification Enable 35: Reverse PID action direction 36: External STOP terminal 1 37: Command source switchover terminal 2 38: PID integral pause 39: Switchover between main frequency source X and preset frequency 40: Switchover between auxiliary frequency source Y and preset frequency 41-42: reserved 43: PID parameter switchover 44: User-defined fault 1 45: User-defined fault 2 46: Speed control/Torque control switchover 47: Emergency stop 48: External STOP terminal 2 49: Deceleration DC braking 50: Clear the current running time 51-59: Reserved	N.A	13 Multi-reference terminal 2	

Function Code	Parameter Name	Setting Range	Unit	Default	Commission
F4-10	DI filter time	0.000 to 1.000	s	0.010	
F4-35	DI1 delay time	0.0 to 3600.0	s	0.0	
F4-36	DI2 delay time	0.0 to 3600.0	s	0.0	
F4-37	DI3 delay time	0.0 to 3600.0	s	0.0	
F4-38	DI active mode selection	7-segment		00000	N.A

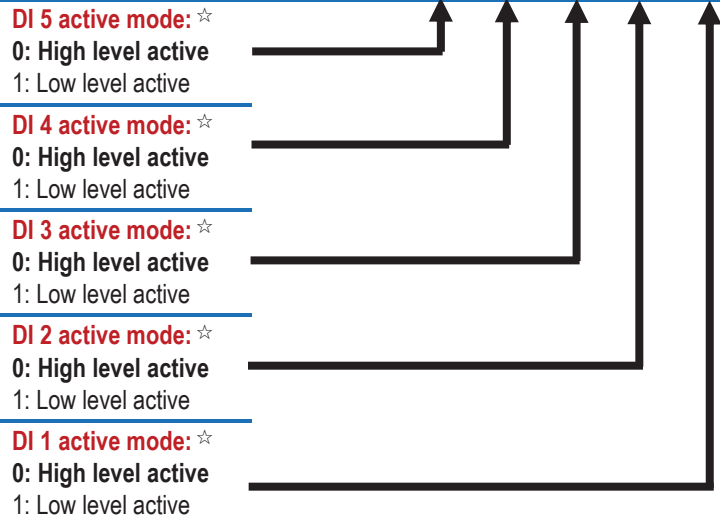

☆: 'High level active' means that, if a high level voltage is applied to DI terminal, the DI signal will be seen as active.
 'Low level active' means that, if a low level voltage is applied to DI terminal, the DI signal will be seen as active.

◆ DO Setting

Function Code	Parameter Name	Setting Range	Unit	Default	Commission
F5-02	Relay function (T/A-T/B-T/C)	0: No output 1: AC drive running state 2: Fault output (stop) 3: Frequency-level detection FDT1 output 4: Frequency reached 5: Zero-speed running (no output at stop) 6: Motor overload pre-warning 7: AC drive overload pre-warning 8: Set count value reached 9: Designated count value reached 10: Length reached 11: PLC cycle complete 12: Accumulative running time reached 13: Frequency limited 14: Reserved 15: Ready for RUN 16: Reserved 17: Frequency upper limit reached 18: Frequency lower limit reached (no output at stop) 19: Undervoltage state output 20: Communication setting 21: Reserved 22: Reserved 23: Zero-speed running 2 (having output at stop) 24: Accumulative power-on time reached 25: Frequency level detection FDT2 output 26: Frequency 1 reached 27: Frequency 2 reached 28: Current 1 reached 29: Current 2 reached 30: Timing reached 31: AI1 input limit exceeded 32: Load becoming 0 33: Reverse running 34: Zero current state 35: Module temperature reached 36: Software current limit exceeded 37: Frequency lower limit reached (having output at stop) 38: Alarm output 39: Reserved 40: Running time reached this time 41: Fault output (There is no output if it is the coast to stop fault and undervoltage occurs.)	N.A	2	Fault output
F5-18	Relay 1 output delay time	0.0 to 3600.0	s	0.0	

Function Code	Parameter Name	Setting Range	Unit	Default	Commission
F5-22	DO active mode selection	7-segment 0 0 0 0 0	N.A	00000	
	Reserved	↑			
	Reserved	↑			
	Reserved	↑			
	Relay 1 active mode:☆	↑			
	0: Positive logic	↑			
	1: Negative logic	↑			
	Reserved	↑			

☆: 'Positive logic' means that, when power on, the relay output terminal T/A-T/B is normally closed, and T/A-T/C is normally open.

'Negative logic' means the opposite situation.

However, no matter the logic is positive or negative, when power off, T/A-T/B is always normally closed, and T/A-T/C is always normally open. F5-22 only changes the state of relay when power on.

Please pay particular attention to the switching of relay if F5-22=1.

✓ Step 9: Set Startup Frequency If Needed

Function Code	Parameter Name	Setting Range	Unit	Default	Commission
F6-03	Startup frequency	0.00 to 10.00	Hz	0.00	
F6-04	Startup frequency active time	0.0 to 100.0	s	0.0	

✓ Step 10: Set S-Curve If Needed

Function Code	Parameter Name	Setting Range	Unit	Default	Commission
F6-07	Acceleration/Deceleration mode	0: Linear mode 1: S-curve mode A 2: S-curve mode B	N.A	0	1
F6-08	Time proportion of S-curve starting segment	0.0 to [100.0 minus F6-09]	%	30.0	
F6-09	Time proportion of S-curve ending segment	0.0 to [100.0 minus F6-08]	%	30.0	

✓ **Step 11: Set DC Injection Braking If Needed**

Function Code	Parameter Name	Setting Range	Unit	Default	Commission
F6-00	Starting mode	0: Direct start 1: reserved 2: Pre-excited start	N.A	0	
F6-05 *	DC Injection Braking 1 level	0 to 100	%	0	
F6-06 *	DC Injection Braking 1 active time	0.0 to 100.0	s	0.0	
F6-11	DC Injection Braking 2 frequency threshold	0.00 to maximum frequency	Hz	0.00	
F6-12	DC Injection Braking 2 delay time	0.0 to 36.0	s	0.0	
F6-13	DC Injection Braking 2 level	0 to 100%	%	0	
F6-14	DC Injection Braking 2 active time	0.0 to 36.0	s	0.0	

*: Only when F6-00=0, the Function codes F6-05 and F6-06 are relative to DC Injection Braking 1.

✓ **Step 12 : Set Pre-Excitation If Needed**

Function Code	Parameter Name	Setting Range	Unit	Default	Commission
F6-00	Starting mode	0: Direct start 1: reserved 2: Pre-excited start	N.A	0	2
F6-05 *	Pre-excitation level	0 to 100	%	0	
F6-06 *	Pre-excitation active time	0.0 to 100.0	s	0.0	

*: Only when F6-00=2, the Function codes F6-05 and F6-06 are relative to Pre-excitation.

CHAPTER 4 TROUBLESHOOTING

4.1 Faults And Solutions

Display	Fault Name	Possible Causes	Solutions
Err02	Overcurrent during acceleration	<ol style="list-style-type: none"> 1. The output circuit is short circuited. 2. The acceleration time is too short. 3. Manual torque boost or V/F curve is not appropriate. 4. The power supply is too low. 5. The startup operation is performed on the rotating motor. 6. A sudden load is added during acceleration. 7. The AC drive model is of too small power class. 	<ol style="list-style-type: none"> 1: Eliminate short circuit. 2: Increase the acceleration time. 3: Adjust the manual torque boost or V/F curve. 4: Check the power supply, and ensure it is normal. 5: Select rotational speed tracking restart or start the motor after it stops. 6: Remove the added load. 7: Select a drive of higher power class.
Err03	Overcurrent during deceleration	<ol style="list-style-type: none"> 1. The output circuit is short circuited. 2. The deceleration time is too short. 3. The power supply is too low. 4. A sudden load is added during deceleration. 5. The braking resistor is not installed. 	<ol style="list-style-type: none"> 1: Eliminate short circuit. 2: Increase the deceleration time. 3: Check the power supply, and ensure it is normal. 4: Remove the added load. 5: Install the braking resistor.
Err04	Overcurrent at constant speed	<ol style="list-style-type: none"> 1. The output circuit is short circuited. 2. The power supply is too low. 3. A sudden load is added during operation. 4. The AC drive model is of too small power class. 	<ol style="list-style-type: none"> 1: Eliminate short circuit. 2: Adjust power supply to normal range. 3: Remove the added load. 4: Select a drive of higher power class.
Err05	Overvoltage during acceleration	<ol style="list-style-type: none"> 1: The DC bus voltage is too high[☆]. 2: An external force drives the motor during acceleration. 3: The acceleration time is too short. 4: The braking resistor is not installed. 	<ol style="list-style-type: none"> 1: Change with a proper braking resistor. 2: Cancel the external force or install braking resistor. 3: Increase the acceleration time. 4: Install the braking resistor.
Err06	Overvoltage during deceleration	<ol style="list-style-type: none"> 1: The DC bus voltage is too high[☆]. 2: An external force drives the motor during deceleration. 3: The deceleration time is too short. 4: The braking resistor is not installed. 	<ol style="list-style-type: none"> 1: Change with a proper braking resistor. 2: Cancel the external force or install braking resistor. 3: Increase the deceleration time. 4: Install the braking resistor
Err07	Overvoltage at constant frequency	<ol style="list-style-type: none"> 1: The DC bus voltage is too high[☆]. 2: An external force drives the motor during deceleration. 	<ol style="list-style-type: none"> 1: Change with a proper braking resistor. 2: Cancel the external force.

[☆]: Voltage thresholds

Voltage Class	DC Bus Overvoltage	DC Bus Undervoltage	Braking Unit Operation Level
Single-phase 220 V	400V	200V	381V
Three-phase 220 V	400V	200V	381V
Three-phase 380 V	810V	350V	700V

Display	Fault Name	Possible Causes	Solutions
Err08	Undervoltage for times	<ol style="list-style-type: none"> 1: Instantaneous power off. 2: The DC bus voltage is too low[☆]. 3: The rectifier bridge and buffer resistor are faulty. 4: The drive board is faulty. 5: The control board is faulty. 	Check the power supply, or seek for maintenance.
Err09	Undervoltage	<ol style="list-style-type: none"> 1: Instantaneous power off. 2: The DC bus voltage is too low[☆]. 3: The rectifier bridge and buffer resistor are faulty. 4: The drive board is faulty. 5: The control board is faulty. 	<ol style="list-style-type: none"> 1: Reset. 2: Check the DC bus. 3 to 6: Seek for maintenance.
Err10	Drive overload	<ol style="list-style-type: none"> 1: The load is too heavy or the rotor is locked. 2: The drive is of too small power class. 	<ol style="list-style-type: none"> 1: Reduce the load, or check the motor, or check the machine whether it is locking the rotor. 2: Select a drive of higher power class.
Err11	Motor overload	<ol style="list-style-type: none"> 1: F9-01 is too small. 2: The load is too heavy or the rotor is locked. 3: The drive is of too small power class. 	<ol style="list-style-type: none"> 1: Set F9-01 correctly. 2: Reduce the load, or check the motor, or check the machine whether it is locking the rotor. 3: Select a drive of larger power class.
Err12	Power input phase loss	<ol style="list-style-type: none"> 1: The three-phase power supply is abnormal. 2: The drive board is faulty. 3: The lightning protection board is faulty. 4: The control board is faulty. 	<ol style="list-style-type: none"> 1: Check the power supply. 2 to 4: Seek for maintenance.
Err13	Power output phase loss	<ol style="list-style-type: none"> 1: The cable between drive and motor is faulty. 2: The drive's three-phase output is unbalanced when the motor is running. 3: The drive board is faulty. 4: The IGBT is faulty. 	<ol style="list-style-type: none"> 1: Check the cable. 2: Check the motor windings. 3 to 4: Seek for maintenance.
Err14	IGBT overheat	<ol style="list-style-type: none"> 1: The ambient temperature is too high. 2: The air filter is blocked. 3: The cooling fan is damaged. 4: The thermal sensor of IGBT is damaged. 5: The IGBT is damaged. 	<ol style="list-style-type: none"> 1: Lower the ambient temperature. 2: Clean the air filter. 3 to 5: Seek for maintenance.
Err15	External equipment fault	<ol style="list-style-type: none"> 1: External fault signal is input via DI. 2: External fault signal is input via virtual Input terminal. 	Reset.
Err16	Communication fault	<ol style="list-style-type: none"> 1: The host computer is abnormal. 2: The communication cable is faulty. 3: The communication parameters in group FD are set improperly. 	<ol style="list-style-type: none"> 1: Check the cabling of host computer. 2: Check the communication cabling. 3: Set the communication parameters properly.
Err18	Current detection fault	<ol style="list-style-type: none"> 1: The HALL device is faulty. 2: The drive board is faulty. 	Seek for maintenance.
Err21	EEPROM read-write fault	The EEPROM chip is damaged.	Seek for maintenance.
Err26	Beyond the accumulative running time limit	The accumulative running time reaches the setting value F8-17.	Clear the record through the parameter initialization function, set FP-01=2.
Err27	User-defined fault 1	<ol style="list-style-type: none"> 1: The user-defined fault 1 signal is input via DI. 2: User-defined fault 1 signal is input via virtual terminal. 	Reset.

Display	Fault Name	Possible Causes	Solutions
Err28	User-defined fault 2	1: The user-defined fault 2 signal is input via DI 2: The user-defined fault 2 signal is input via virtual terminal.	Reset.
Err29	Beyond the accumulative power-on time limit	The accumulative power-on time reaches the setting value F8-16.	Clear the record through the parameter initialization function, set FP-01=2.
Err30	Off load fault	The running current is lower than F9-64.	Check that the load is disconnected or the setting of F9-64 and F9-65 is correct.
Err31	PID feedback lost during running	The PID feedback is lower than FA-26.	Check the PID feedback signal or set FA-26 to a proper value.
Err40	Beyond a particular current limit for times	1: The load is too heavy or the rotor is locked. 2: The drive is of too small power class.	1: Reduce the load, or check the motor, or check the machine whether it is locking the rotor. 2: Select a drive of higher power class.
Err42	Too large speed deviation	F9-69 and F9-70 are set incorrectly.	Set F9-69 and F9-70 correctly.
Err43	Motor overspeed	1: The encoder parameters are set incorrectly. 2: F9-69 and F9-70 are set incorrectly.	1: Set the encoder parameters properly. 2: Set F9-69 and F9-70 correctly.
Err51	Initial position fault	The motor parameters are wrong.	Check the motor parameters, and check whether the rated current is set too small.

4.2 Common Symptoms And Diagnostics

Fault Name	Possible Causes	Solutions
There is no display at power-on.	<ol style="list-style-type: none"> 1. There is no power supply or the power supply is too low. 2. The switching power supply on drive board is faulty. 3. The rectifier bridge is damaged. 4. The buffer resistor of drive is damaged. 5. The control board or the keypad is faulty. 6. The cable between control board and drive board or keypad breaks. 	<ol style="list-style-type: none"> 1. Check the power supply. 2 to 5. Seek for maintenance. 6. Re-connect the 4-core and 28-core flat cables, or seek for maintenance.
“HC” is displayed at power-on.	<ol style="list-style-type: none"> 1. The cable between drive board and control board is in poor contact. 2. The control board is damaged. 3. The motor winding or the motor cable is short circuited to the ground. 4. The power supply is too low. 	<ol style="list-style-type: none"> 1. Re-connect the 4-core and 28-core flat cables, or seek for maintenance. 2. Seek for maintenance. 3. Check the motor or replace it, and check the motor cable. 4. Check the power supply according to chapter 1.3.
The display is normal upon power-on. But “HC” is displayed after getting started while the motor stops immediately.	<ol style="list-style-type: none"> 1. The cooling fan is damaged or the rotor is locked. 2. Some terminal is short circuited. 	<ol style="list-style-type: none"> 1. Replace cooling fan, or check the machine whether it is locking the rotor. 2. Eliminate short circuit.
Err14 is reported frequently.	<ol style="list-style-type: none"> 1. The setting value of carrier frequency is too high. 2. The cooling fan is damaged, or the air filter is blocked. 3. Components inside the drive are damaged (thermal coupler or others). 	<ol style="list-style-type: none"> 1. Reduce F0-15. 2. Replace the fan and clean the air filter. 3. Seek for maintenance.
The motor does not rotate after the AC drive outputs nonzero reference.	<ol style="list-style-type: none"> 1. Motor or motor cable is damaged. 2. The parameters are set improperly (motor parameters). 3. The cable between drive board and control board is in poor contact. 4. The drive board is faulty. 5. The rotor is locked. 	<ol style="list-style-type: none"> 1. Check motor, or check the cable between drive and motor. 2. Check and re-set motor parameters. 3. Re-connect the 4-core and 28-core flat cables, or seek for maintenance. 4. Seek for maintenance. 5. Check the machine whether it is locking the rotor.
The DI terminals are disabled.	<ol style="list-style-type: none"> 1. The DI parameters are set incorrectly. 2. The input signal is incorrect. 3. The wire jumper between OP and +24 V is in poor contact. 4. The control board is faulty. 	<ol style="list-style-type: none"> 1. Check and reset DI parameters in group F4. 2. Check the input signals, or check the input cable. 3. Check the jumper between OP and +24 V. 4. Seek for maintenance.
The drive reports overcurrent and overvoltage frequently.	<ol style="list-style-type: none"> 1. The motor parameters are set improperly. 2. The acceleration/deceleration time is too small. 3. The load fluctuates. 	<ol style="list-style-type: none"> 1. Reset motor parameters. 2. Set proper acceleration/deceleration time. 3. Check the machine, or seek for support.
 is displayed upon power-on.	Some parts on control board are damaged.	Seek for maintenance.

CHAPTER 5 FUNCTION CODE TABLE

5.1 General Function Codes

✓ Group F0: Standard

Function Code	Parameter Name	Setting Range	Unit	Default	Commission
F0-01	Motor control mode	2: Voltage/Frequency control (V/F)	N.A	2	
F0-02	Command source selection	0 to 2	N.A	0	
F0-03	Main frequency source X selection	0 to 9	N.A	0	
F0-04	Auxiliary frequency source Y selection	The same as F0-03 (Main frequency source X selection)	N.A	0	
F0-05	Range of auxiliary frequency Y for X and Y operation	0: Relative to maximum frequency 1: Relative to main frequency X	N.A	0	
F0-06	Range of auxiliary frequency Y for X and Y operation	0 to 150	%	100	
F0-07	Frequency source selection	00 to 34	N.A	00	
F0-08	Preset frequency	0.00 to maximum frequency	N.A	50.00	
F0-09	Rotation direction	0: Same direction 1: Reverse direction	N.A	0	
F0-10	Maximum frequency	50.00 to 600.00	Hz	50.00	
F0-11	Source of frequency upper limit	0 to 5	N.A	0	
F0-12	Frequency upper limit	Frequency lower limit (F0-14) to maximum frequency (F0-10)	Hz	50.00	
F0-13	Frequency upper limit offset	0.00 to maximum frequency (F0-10)	Hz	0.00	
F0-14	Frequency lower limit	0.00 to frequency upper limit (F0-12)	Hz	0.00	
F0-15	Carrier frequency	0.5 to 16.0	kHz	Model dependent	
F0-16	Carrier frequency adjustment with temperature	0: No 1: Yes	N.A	1	
F0-17	Acceleration time 1	0.00 to 650.00 (if F0-19=2) 0.0 to 6500.0 (if F0-19=1) 0 to 65000 (if F0-19=0)	s	Model dependent	
F0-18	Deceleration time 1	0.00 to 650.00 (if F0-19=2) 0.0 to 6500.0 (if F0-19=1) 0 to 65000 (if F0-19=0)	s	Model dependent	
F0-19	Acceleration/Deceleration time unit	0: 1 1: 0.1 2: 0.01	s	1	
F0-21	Frequency offset of auxiliary frequency source for X and Y operation	0.00 to maximum frequency (F0-10)	Hz	0.00	
F0-22	Frequency reference resolution	1: 0.1 2: 0.01	Hz	2	
F0-23	Retentive of digital setting frequency upon power failure	0: Not retentive 1: Retentive	N.A	2	
F0-25	Acceleration/Deceleration time base frequency	0: Maximum frequency (F0-10) 1: Frequency reference 2: 100	N.A	0	
F0-26	Base frequency for UP/DOWN modification during running	0: Running frequency 1: Frequency reference	N.A	0	

F0-27	Binding command source to frequency source	0000 to 9999	N.A	0000	
-------	--	--------------	-----	------	--

✓ **Group F1: Motor Parameters**

Function Code	Parameter Name	Setting Range	Unit	Default	Commission
F1-00	Motor type	0: Common asynchronous motor 1: Variable frequency asynchronous motor	N.A	0	
F1-01	Rated motor power	0.1 to 7.5	kW	Model dependent	
F1-02	Rated motor voltage	1 to 1000	V	Model dependent	
F1-03	Rated motor current	0.01 to 655.35	A	Model dependent	
F1-04	Rated motor frequency	0.01 to max frequency	Hz	Model dependent	
F1-05	Rated motor rotational speed	1 to 65535	RPM	Model dependent	
F1-06	Stator resistance (asynchronous motor)	0.001 to 65.535	Ω	Model dependent	
F1-10	No-load current (asynchronous motor)	0.01 to F1-03	A	Model dependent	

✓ **Group F3: V/F Control**

Function Code	Parameter Name	Setting Range	Unit	Default	Commission
F3-00	V/F curve setting	0 to 9	N.A	0	
F3-01	Torque boost	0.0 to 30.0	%	Model dependent	
F3-02	Cut-off frequency of torque boost	0.00 to maximum output frequency	Hz	50.00	
F3-03	Multi-point V/F frequency 1 (F1)	0.00 to F3-05	Hz	0.00	
F3-04	Multi-point V/F voltage 1 (V1)	0.0 to 100.0	%	0.0	
F3-05	Multi-point V/F frequency 2 (F2)	F3-03 to F3-07	Hz	0.00	
F3-06	Multi-point V/F voltage 2 (V2)	0.0 to 100.0	%	0.0	
F3-07	Multi-point V/F frequency 3 (F3)	F3-05 to rated motor frequency (F1-04)	Hz	0.00	
F3-08	Multi-point V/F voltage 3 (V3)	0.0 to 100.0	%	0.0	
F3-09	V/F slip compensation gain	0 to 200.0	%	0.0	
F3-10	V/F over-excitation gain	0 to 200	%	64	
F3-11	V/F oscillation suppression gain	0 to 100	%	Model dependent	

✓ Group F4: Input Terminals

Function Code	Parameter Name	Setting Range	Unit	Default	Commission
F4-00	DI1 function selection	0 to 59	N.A	1	
F4-01	DI2 function selection	0 to 59	N.A	4	
F4-02	DI3 function selection	0 to 59	N.A	9	
F4-03	DI4 function selection	0 to 59	N.A	12	
F4-04	DI5 function selection	0 to 59	N.A	13	
F4-10	DI filter time	0.000 to 1.000	s	0.010	
F4-11	Terminal wiring mode selection	0: Two-line mode 1 1: Two-line mode 2 2: Three-line mode 1 3: Three-line mode 2	N.A	0	
F4-12	Terminal UP/DOWN rate	0.01 to 65.535	Hz/s	1.00	
F4-13	AI curve 1 minimum input	0.00 to F4-15	V	0.00	
F4-14	Corresponding setting of AI curve1 minimum input	-100.0 to 100.0	%	0.0	
F4-15	AI curve 1 maximum input	F4-13 to 10.00	V	10.00	
F4-16	Corresponding setting of AI curve1 maximum input	-100.0 to 100.0	%	100.0	
F4-17	AI1 filter time	0.00 to 10.00	s	0.10	
F4-18	AI curve 2 minimum input	0.00 to F4-20	V	0.00	
F4-19	Corresponding setting of AI curve2 minimum input	-100.0 to 100.0	%	0.0	
F4-20	AI curve 2 maximum input	F4-18 to 10.00	V	10.00	
F4-21	Corresponding setting of AI curve2 maximum input	-100.0 to 100.0	%	100.0	
F4-22	AI2 filter time	0.00 to 10.00	s	0.10	
F4-23	AI curve 3 minimum input	0.00 to F4-25	V	0.00	
F4-24	Corresponding setting of AI curve3 minimum input	-100.0 to 100.0	%	0.0	
F4-25	AI curve 3 maximum input	F4-23 to 10.00	V	10.00	
F4-26	Corresponding setting of AI curve3 maximum input	-100.0 to 100.0	%	100.0	
F4-27	AI3 filter time	0.00 to 10.00	s	0.10	
F4-28	Pulse minimum input	0.00 to F4-30	kHz	0.00	
F4-29	Corresponding setting of pulse minimum input	-100.0 to 100.0	%	0.0	
F4-30	Pulse maximum input	F4-28 to 50.00	kHz	50.00	
F4-31	Corresponding setting of pulse maximum input	-100.0 to 100.0	%	100.0	
F4-32	Pulse filter time	0.00 to 10.00	s	0.10	
F4-33	AI curve selection	111 to 555	N.A	321	

Function Code	Parameter Name	Setting Range	Unit	Default	Commission
F4-34	Setting for AI less than minimum input	000 to 111	N.A	000	
F4-35	DI1 delay time	0.0 to 3600.0	s	0.0	
F4-36	DI2 delay time	0.0 to 3600.0	s	0.0	
F4-37	DI3 delay time	0.0 to 3600.0	s	0.0	
F4-38	DI active mode selection	00000 to 11111	N.A	00000	

✓ **Group F5: Output Terminals**

Function Code	Parameter Name	Setting Range	Unit	Default	Commission
F5-02	Relay function (T/A-T/B-T/C)	0 to 41	N.A	2	
F5-07	AO1 function selection	0 to 16	N.A	0	
F5-10	AO1 offset coefficient	-100.0 to 100.0	%	0.0	
F5-11	AO1 gain	-10.00 to 10.00	N.A	1.00	
F5-18	Relay 1 output delay time	0.0 to 3600.0	s	0.0	
F5-22	DO active mode selection	00000 to 11111	N.A	00000	

✓ **Group F6: Start/Stop Control**

Function Code	Parameter Name	Setting Range	Unit	Default	Commission
F6-00	Start mode	0: Direct start 1: reserved 2: Pre-excited start (asynchronous motor)	N.A	0	
F6-03	Startup frequency	0.00 to 10.00	Hz	0.00	
F6-04	Startup frequency active time	0.0 to 100.0	s	0.0	
F6-05	DC Injection Braking 1 level/ Pre-excitation level	0 to 100	%	0	
F6-06	DC Injection Braking 1 active time/ Pre-excitation active time	0.0 to 100.0	s	0.0	
F6-07	Acceleration/ Deceleration mode	0: Linear mode 1: S-curve mode A 2: S-curve mode B	N.A	0	
F6-08	Time proportion of S-curve starting segment	0.0 to (100.0 minus F6-09)	%	30.0	
F6-09	Time proportion of S-curve ending segment	0.0 to (100.0 minus F6-08)	%	30.0	
F6-10	Stop mode	0: Decelerate to stop 1: Coast to stop	N.A	0	
F6-11	DC Injection Braking 2 frequency threshold	0.00 to maximum frequency	Hz	0.00	
F6-12	DC Injection Braking 2 delay time	0.0 to 36.0	s	0.0	
F6-13	DC Injection Braking 2 level	0 to 100	%	0	
F6-14	DC Injection Braking 2 active time	0.0 to 36.0	s	0.0	
F6-15	Brake use ratio	0 to 100	%	100	

✓ **Group F7: Keypad Operation And LED Display**

Function Code	Parameter Name	Setting Range	Unit	Default	Commission
F7-01	MF.K Key function selection	0 to 5	N.A	0	
F7-02	STOP/RESET key function	0 to 1	N.A	1	
F7-03	LED display running parameters 1	0000 to FFFF	N.A	1F	
F7-04	LED display running parameters 2	0000 to FFFF	N.A	0	
F7-05	LED display stop parameters	0000 to FFFF	N.A	33	
F7-06	Load speed display coefficient	0.0001 to 6.5000	N.A	1.0000	
F7-09	Accumulative running time	0 to 65535	h	-	
F7-10	Product number	-	-	-	
F7-11	Software version	-	-	-	
F7-12	Number of decimal places for load speed display	0: 0 decimal place 1: 1 decimal place 2: 2 decimal places 3: 3 decimal places	N.A	1	
F7-13	Accumulative power-on time	0 to 65535	h	-	
F7-14	Accumulative power consumption	0 to 65535	kWh	-	

✓ Group F8: Auxiliary Functions

Function Code	Parameter Name	Setting Range	Unit	Default	Commission
F8-00	JOG running frequency	0.00 to maximum frequency	Hz	2.00	
F8-01	JOG acceleration time	0.0 to 6500.0	s	20.0	
F8-02	JOG deceleration time	0.0 to 6500.0	s	20.0	
F8-03	Acceleration time 2	0.0 to 6500.0	s	Model dependent	
F8-04	Deceleration time 2	0.0 to 6500.0	s	Model dependent	
F8-05	Acceleration time 3	0.0 to 6500.0	s	Model dependent	
F8-06	Deceleration time 3	0.0 to 6500.0	s	Model dependent	
F8-07	Acceleration time 4	0.0 to 500.0	s	Model dependent	
F8-08	Deceleration time 4	0.0 to 6500.0	s	Model dependent	
F8-09	Jump frequency 1	0.00 to maximum frequency	Hz	0.00	
F8-10	Jump frequency 2	0.00 to maximum frequency	Hz	0.00	
F8-11	Frequency jump amplitude	0.00 to maximum frequency	Hz	0.00	
F8-12	Forward/Reverse rotation dead-zone time	0.0 to 3000.0	s	0.0	
F8-13	Reverse control	0: Enabled 1: Disabled	N.A	0	
F8-14	Running mode when Frequency reference lower than frequency lower limit	0: Run at frequency lower limit 1: Stop 2: Run at zero speed	N.A	0	
F8-15	Droop control	0.00 to 10.00	Hz	0.00	
F8-16	Accumulative power-on time threshold	0 to 65000	h	0	
F8-17	Accumulative running time threshold	0 to 65000	h	0	
F8-18	Startup protection	0: No 1: Yes	N.A	0	
F8-19	Frequency detection value (FDT1)	0.00 to maximum frequency	Hz	50.00	
F8-20	Frequency detection hysteresis (FDT1hysteresis)	0.0 to 100.0 (FDT1 level)	%	5.0	
F8-21	Detection range of frequency reached	0.00 to 100 (maximum frequency)	%	0.0	
F8-22	Jump frequency during acceleration/deceleration	0: Disabled 1: Enabled	N.A	0	
F8-27	Terminal JOG priority	0: Disabled 1: Enabled	N.A	0	
F8-28	Frequency detection value (FDT2)	0.00 to maximum frequency	N.A	50.00	
F8-29	Frequency detection hysteresis (FDT2 hysteresis)	0.0 to 100.0 (FDT2 level)	%	5.0	
F8-30	Any frequency reaching detection value 1	0.00 to maximum frequency	Hz	50.00	
F8-31	Any frequency reaching detection amplitude 1	0.0 to 100.0 (maximum frequency)	%	0.0	
F8-32	Any frequency reaching detection value 2	0.00 to maximum frequency	Hz	50.00	

Function Code	Parameter Name	Setting Range	Unit	Default	Commission
F8-33	Any frequency reaching detection amplitude 2	0.0 to 100.0 (maximum frequency)	%	0.0	
F8-34	Zero current detection level	0.0 to 300.0 (rated motor current as 100%)	%	5.0	
F8-35	Zero current detection delay	0.01 to 600.00	s	0.10	
F8-36	Output overcurrent threshold	0.0 (no detection) 0.1 to 300.0 (rated motor current)	%	200.0	
F8-37	Output overcurrent detection delay time	0.00 to 600.00	s	0.00	
F8-38	Any current reaching 1	0.0 to 300.0 (rated motor current)	%	100.0	
F8-39	Any current reaching 1 amplitude	0.0 to 300.0 (rated motor current)	%	0.0	
F8-40	Any current reaching 2	0.0 to 300.0 (rated motor current)	%	100.0	
F8-41	Any current reaching 2 amplitude	0.0 to 300.0 (rated motor current)	%	0.0	
F8-42	Timing function	0: Disabled 1: Enabled	N.A	0	
F8-43	Timing duration source	0 to 3	N.A	0	
F8-44	Timing duration	0.0 to 6500.0	min	0.0	
F8-45	AI1 input voltage lower limit	-11.00 to F8-46	V	3.10	
F8-46	AI1 input voltage upper limit	F8-45 to 11.00	V	6.80	
F8-47	Module temperature threshold	0 to 100	°C	75	
F8-48	Cooling fan control	0: Fan working during running 1: Fan working continuously	N.A	0	
F8-49	Wakeup frequency	Dormant frequency (F8-51) to maximum frequency (F0-10)	Hz	0.00	
F8-50	Wakeup delay time	0.0 to 6500.0	s	0.0	
F8-51	Dormant frequency	0.00 to wakeup frequency (F8-49)	Hz	0.00	
F8-52	Dormant delay time	0.0 to 6500.0	s	0.0	
F8-53	Current running time reached	0.0 to 6500.0	min	0.0	

✓ Group F9: Fault And Protection

Function Code	Parameter Name	Setting Range	Unit	Default	Commission
F9-00	Motor overload protection selection	0: Disabled 1: Enabled	N.A	1	
F9-01	Motor overload protection gain	0.20 to 10.00	N.A	1.00	
F9-02	Motor overload warning coefficient	50 to 100	%	80	
F9-03	Overvoltage stall gain	0 to 100	N.A	0	
F9-04	Overvoltage stall protective voltage	120 to 150	%	130	
F9-05	Overcurrent stall gain	0 to 100	N.A	20	
F9-06	Overcurrent stall protective current	100 to 200	%	150	
F9-07	Short-circuit to ground upon power-on	0: Disabled 1: Enabled	N.A	1	
F9-09	Fault auto reset times	0 to 20	N.A	0	
F9-10	DO action during fault auto reset	0: Not act 1: Act	N.A	0	
F9-11	Time interval of fault auto reset	0.1 to 100.0	s	1.0	
F9-12	Input phase loss protection selection	0: Disabled 1: Enabled	N.A	0	
F9-13	Output phase loss protection selection	0: Disabled 1: Enabled	N.A	1	
F9-14	1st fault type	0 to 51	N.A	-	
F9-15	2nd fault type	0 to 51	N.A	-	
F9-16	3rd (latest) fault type	0 to 51	N.A	-	
F9-17	Frequency upon 3rd fault	-	-	-	
F9-18	Current upon 3rd fault	-	-	-	
F9-19	Bus voltage upon 3rd fault	-	-	-	
F9-20	DI status upon 3rd fault	-	-	-	
F9-21	Output terminal status upon 3rd fault	-	-	-	
F9-22	AC drive status upon 3rd fault	-	-	-	
F9-23	Power-on time upon 3rd fault	-	-	-	
F9-24	Running time upon 3rd fault	-	-	-	
F9-27	Frequency upon 2nd fault	-	-	-	
F9-28	Current upon 2nd fault	-	-	-	
F9-29	Bus voltage upon 2nd fault	-	-	-	
F9-30	DI status upon 2nd fault	-	-	-	
F9-31	Output terminal status upon 2nd fault	-	-	-	
F9-32	Frequency upon 2nd fault	-	-	-	
F9-33	Current upon 2nd fault	-	-	-	
F9-34	Bus voltage upon 2nd fault	-	-	-	
F9-37	DI status upon 1st fault	-	-	-	
F9-38	Output terminal status upon 1st fault	-	-	-	

Function Code	Parameter Name	Setting Range	Unit	Default	Commission
F9-39	Frequency upon 1st fault	-	-	-	
F9-40	Current upon 1st fault	-	-	-	
F9-41	Bus voltage upon 3rd fault	-	-	-	
F9-42	DI status upon 1st fault	-	-	-	
F9-43	Output terminal status upon 1st fault	-	-	-	
F9-44	Frequency upon 1st fault	-	-	-	
F9-47	Fault protection action selection 1	00000 to 22222	N.A	0000	
F9-48	Fault protection action selection 2	00000 to 11111	N.A	0000	
F9-49	Fault protection action selection 3	00000 to 22222	N.A	0000	
F9-54	Frequency selection for continuing to run upon fault	0 to 4	N.A	0	
F9-55	Backup frequency upon abnormality	0.0 to 100.0 (maximum frequency)	Hz	100.0	
F9-59	Action selection at instantaneous power failure	0: Invalid 1: Decelerate 2: Decelerate to stop	N.A	0	
F9-60	Action pause judging voltage at instantaneous power failure	80.0 to 100.0	%	90.0	
F9-61	Voltage rally judging time at instantaneous power failure	0.00 to 100.00	s	0.50	
F9-62	Action judging voltage at instantaneous power failure	60.0 to 100.0 (standard bus voltage)	%	80.0	
F9-63	Protection upon load becoming 0	0: Disabled 1: Enabled	N.A	0	

✓ **Group FA: Process Control And PID Function**

Function Code	Parameter Name	Setting Range	Unit	Default	Commission
FA-00	PID setting source	0 to 6	N.A	0	
FA-01	PID digital setting	0.0 to 100.0	%	50.0	
FA-02	PID feedback source	0 to 8	N.A	0	
FA-03	PID action direction	0: Forward action 1: Reverse action	N.A	0	
FA-04	PID setting feedback range	0 to 65535	N.A	1000	
FA-05	Proportional gain Kp1	0.0 to 100.0	N.A	20.0	
FA-06	Integral time Ti1	0.01 to 10.00	s	2.00	
FA-07	Differential time Td1	0.00 to 10.000	s	0.000	
FA-08	Cut-off frequency of PID reverse rotation	0.00 to maximum frequency	Hz	2.00	
FA-09	PID deviation limit	0.0 to 100.0	%	0.0	
FA-10	PID differential limit	0.00 to 100.00	%	0.10	
FA-11	PID setting change time	0.00 to 650.00	s	0.00	
FA-12	PID feedback filter time	0.00 to 60.00	s	0.00	
FA-13	PID output filter time	0.00 to 60.00	s	0.00	
FA-14	Reserved	-		-	
FA-15	Proportional gain Kp2	0.0 to 100.0	N.A	20.0	
FA-16	Integral time Ti2	0.01 to 10.00	s	2.00	
FA-17	Differential time Td2	0.000 to 10.000	s	0.000	
FA-18	PID parameter switchover condition	0 to 2	N.A	0	
FA-19	PID parameter switchover deviation 1	0.0 to FA-20	%	20.0	
FA-20	PID parameter switchover deviation 2	FA-19 to 100.0	%	80.0	
FA-21	PID initial value	0.0 to 100.0	%	0.0	
FA-22	PID initial value holding time	0.00 to 650.00	s	0.00	
FA-23	Maximum deviation between two PID outputs in forward direction	0.00 to 100.00	%	1.00	
FA-24	Maximum deviation between two PID outputs in reverse direction	0.00 to 100.00	%	1.00	
FA-25	PID integral property	00 to 11	N.A	00	
FA-26	Detection value of PID feedback loss	0.0: Not judging feedback loss 0.1 to 100.0	%	0.0	
FA-27	Detection time of PID feedback loss	0.0 to 20.0	s	0.0	
FA-28	PID operation at stop	0: No PID operation at stop 1: PID operation at stop	N.A	0	

✓ **Group FB: Swing Frequency, Fixed Length And Count**

Function Code	Parameter Name	Setting Range	Unit	Default	Commission
FB-00	Swing frequency setting mode	0: Relative to the central frequency 1: Relative to the maximum frequency	N.A	0	
FB-01	Swing frequency amplitude	0.0 to 100.0	%	0.0	
FB-02	Jump frequency amplitude	0.0 to 50.0	%	0.0	
FB-03	Swing frequency cycle	0.0 to 3000.0	s	10.0	
FB-04	Triangular wave rising time coefficient	0.0 to 100.0	%	50.0	
FB-05	Set length	0 to 65535	m	1000	
FB-06	Actual length	0 to 65535	m	0	
FB-07	Number of pulses per meter	0.1 to 6553.5	N.A	100.0	
FB-08	Set count value	1 to 65535	N.A	1000	
FB-09	Designated count value	1 to 65535	N.A	1000	

✓ **Group FC: Multi-Reference And Simple PLC Function**

Function Code	Parameter Name	Setting Range	Unit	Default	Commission
FC-00	Reference 0	-100.0 to 100.0	%	0.0	
FC-01	Reference 1	-100.0 to 100.0	%	0.0	
FC-02	Reference 2	-100.0 to 100.0	%	0.0	
FC-03	Reference 3	-100.0 to 100.0	%	0.0	
FC-04	Reference 4	-100.0 to 100.0	%	0.0	
FC-05	Reference 5	-100.0 to 100.0	%	0.0	
FC-06	Reference 6	-100.0 to 100.0	%	0.0	
FC-07	Reference 7	-100.0 to 100.0	%	0.0	
FC-08	Reference 8	-100.0 to 100.0	%	0.0	
FC-09	Reference 9	-100.0 to 100.0	%	0.0	
FC-10	Reference 10	-100.0 to 100.0	%	0.0	
FC-11	Reference 11	-100.0 to 100.0	%	0.0	
FC-12	Reference 12	-100.0 to 100.0	%	0.0	
FC-13	Reference 13	-100.0 to 100.0	%	0.0	
FC-14	Reference 14	-100.0 to 100.0	%	0.0	
FC-15	Reference 15	-100.0 to 100.0	%	0.0	
FC-16	Simple PLC running mode	0 to 2	N.A	0	
FC-17	Simple PLC retentive selection	00 to 11	N.A	00	
FC-18	Running time of simple PLC reference 0	0.0 to 6553.5	s or h	0.0	
FC-19	Acceleration/deceleration time of simple PLC reference 0	0 to 3	N.A	0	
FC-20	Running time of simple PLC reference 1	0.0 to 6553.5	s or h	0.0	
FC-21	Acceleration/deceleration time of simple PLC reference 1	0 to 3	N.A	0	
FC-22	Running time of simple PLC reference 2	0.0 to 6553.5	s or h	0.0	
FC-23	Acceleration/deceleration time of simple PLC reference 2	0 to 3	N.A	0	
FC-24	Running time of simple PLC reference 3	0.0 to 6553.5	s or h	0.0	
FC-25	Acceleration/deceleration time of simple PLC reference 3	0 to 3	N.A	0	
FC-26	Running time of simple PLC reference 4	0.0 to 6553.5	s or h	0.0	
FC-27	Acceleration/deceleration time of simple PLC reference 4	0 to 3	N.A	0	
FC-28	Running time of simple PLC reference 5	0.0 to 6553.5	s or h	0.0	
FC-29	Acceleration/deceleration time of simple PLC reference 5	0 to 3	N.A	0	
FC-30	Running time of simple PLC reference 6	0.0 to 6553.5	s or h	0.0	

Function Code	Parameter Name	Setting Range	Unit	Default	Commission
FC-31	Acceleration/deceleration time of simple PLC reference 6	0 to 3	N.A	0	
FC-32	Running time of simple PLC reference 7	0.0 to 6553.5	s or h	0.0	
FC-33	Acceleration/deceleration time of simple PLC reference 7	0 to 3	N.A	0	
FC-34	Running time of simple PLC reference 8	0.0 to 6553.5	s or h	0.0	
FC-35	Acceleration/deceleration time of simple PLC reference 8	0 to 3	N.A	0	
FC-36	Running time of simple PLC reference 9	0.0 to 6553.5	s or h	0.0	
FC-37	Acceleration/deceleration time of simple PLC reference 9	0 to 3	N.A	0	
FC-38	Running time of simple PLC reference 10	0.0 to 6553.5	s or h	0.0	
FC-39	Acceleration/deceleration time of simple PLC reference 10	0 to 3	N.A	0	
FC-40	Running time of simple PLC reference 11	0.0 to 6553.5	s or h	0.0	
FC-41	Acceleration/deceleration time of simple PLC reference 11	0 to 3	N.A	0	
FC-42	Running time of simple PLC reference 12	0.0 to 6553.5	s or h	0.0	
FC-43	Acceleration/deceleration time of simple PLC reference 12	0 to 3	N.A	0	
FC-44	Running time of simple PLC reference 13	0.0 to 6553.5	s or h	0.0	
FC-45	Acceleration/deceleration time of simple PLC reference 13	0 to 3	N.A	0	
FC-46	Running time of simple PLC reference 14	0.0 to 6553.5	s or h	0.0	
FC-47	Acceleration/deceleration time of simple PLC reference 14	0 to 3	N.A	0	
FC-48	Running time of simple PLC reference 15	0.0 to 6553.5	s or h	0.0	
FC-49	Acceleration/deceleration time of simple PLC reference 15	0 to 3	N.A	0	
FC-50	Time unit of simple PLC running	0: s (second); 1: h (hour)	N.A	0	
FC-51	Reference 0 source	0 to 6	N.A	0	

✓ **Group FD: Communication**

Function Code	Parameter Name	Setting Range	Unit	Default	Commission
FD-00	Baud rate	0000 to 9999	N.A	6005	
FD-01	Data format	0 to 3	N.A	0	
FD-02	Local address	0: Broadcast address; 1 to 247	N.A	1	
FD-03	Response delay	0 to 20	ms	2	
FD-04	Communication timeout	0.0 (invalid); 0.1 to 60.0	s	0.0	
FD-05	Modbus protocol selection	00 to 11	N.A	00	
FD-06	Current unit in communication	0: 0.01 1: 0.1	A	0	

✓ **Group FP: Function Code Management**

Function Code	Parameter Name	Setting Range	Unit	Default	Commission
FP-00	User password	0 to 65535	N.A	0	
FP-01	Restore default settings	0: No operation 01: Restore factory settings except motor parameters 02: Clear records 04: Restore user backup parameters 501: Back up current user parameters	N.A	0	
FP-02	AC drive parameter display property	00 to 11	N.A	11	
FP-03	Individualized parameter display property	00 to 11	N.A	00	
FP-04	Parameter modification property	0: Modifiable 1: Not modifiable	N.A	0	

✓ **Group A1: Virtual DI/DO**

Function Code	Parameter Name	Setting Range	Unit	Default	Commission
A1-00	VDI1 function selection	0 to 59	N.A	0	
A1-01	VDI2 function selection	0 to 59	N.A	0	
A1-02	VDI3 function selection	0 to 59	N.A	0	
A1-03	VDI4 function selection	0 to 59	N.A	0	
A1-04	VDI5 function selection	0 to 59	N.A	0	
A1-05	VDI state setting mode	00000 to 11111	N.A	00000	
A1-06	VDI state selection	00000 to 11111	N.A	00000	
A1-07	Function selection for AI1 used as DI	0 to 59	N.A	0	
A1-10	State selection for AI used as DI	000 to 111	N.A	000	
A1-11	VDO1 function selection	0 to 41	N.A	0	
A1-12	VDO2 function selection	0 to 41	N.A	0	
A1-13	VDO3 function selection	0 to 41.	N.A	0	
A1-14	VDO4 function selection	0 to 41	N.A	0	
A1-15	VDO5 function selection	0 to 41	N.A	0	
A1-16	VDO1 output delay	0.0 to 3600.0	s	0.0	
A1-17	VDO2 output delay	0.0 to 3600.0	s	0.0	
A1-18	VDO3 output delay	0.0 to 3600.0	s	0.0	
A1-19	VDO4 output delay	0.0 to 3600.0	s	0.0	
A1-20	VDO5 output delay	0.0 to 3600.0	s	0.0	
A1-21	VDO state selection	00000 to 11111	N.A	00000	

✓ **Group A5: Control Optimization**

Function Code	Parameter Name	Setting Range	Unit	Default	Commission
A5-00	DPWM switchover frequency upper limit	0.00 to 15.00	Hz	12.00	
A5-01	PWM modulation mode	0: Asynchronous modulation 1: Synchronous modulation	N.A	0	
A5-02	Dead zone compensation mode selection	0: No compensation 1: Compensation	N.A	1	
A5-03	Random PWM depth	0 to 10	N.A	0	
A5-04	Rapid current limit	0: Disabled 1: Enabled	N.A	1	

✓ **Group A6: AI Curve Setting**

Function Code	Parameter Name	Setting Range	Unit	Default	Commission
A6-00	AI curve 4 minimum input	-10.00 to A6-02	V	0.00	
A6-01	Corresponding setting of AI curve 4 minimum input	-100.0 to 100.0	%	0.0	
A6-02	AI curve 4 inflexion 1 input	A6-00 to A6-04	V	3.00	
A6-03	Corresponding setting of AI curve 4 inflexion 1 input	-100.0 to 100.0	%	30.0	
A6-04	AI curve 4 inflexion 1 input	A6-02 to A6-06	V	6.00	
A6-05	Corresponding setting of AI curve 4 inflexion 1 input	-100.0 to 100.0	%	60.0	
A6-06	AI curve 4 maximum input	A6-06 to 10.00	V	10.00	
A6-07	Corresponding setting of AI curve 4 maximum input	-100.0 to 100.0	%	100.0	
A6-08	AI curve 5 minimum input	-10.00 to A6-10	V	0.00	
A6-09	Corresponding setting of AI curve 5 minimum input	-100.0 to 100.0	%	0.0	
A6-10	AI curve 5 inflexion 1 input	A6-08 to A6-12	V	3.00	
A6-11	Corresponding setting of AI curve 5 inflexion 1 input	-100.0 to 100.0	%	30.0	
A6-12	AI curve 5 inflexion 1 input	A6-10 to A6-14	V	6.00	
A6-13	Corresponding setting of AI curve 5 inflexion 1 input	-100.0 to 100.0	%	60.0	
A6-14	AI curve 5 maximum input	A6-14 to 10.00	V	10.00	
A6-15	Corresponding setting of AI curve 5 maximum input	-100.0 to 100.0	%	100.0	
A6-24	Jump point of AI1 input corresponding setting	-100.0 to 100.0	%	0.0	
A6-25	Jump amplitude of AI1 input corresponding setting	0.0 to 100.0	%	0.5	

✓ **Group AC: AI/AO Correction**

Function Code	Parameter Name	Setting Range	Unit	Default	Commission
AC-00	AI1 measured voltage 1	0.500 to 4.000	V	Factory corrected	
AC-01	AI1 displayed voltage 1	0.500 to 4.000	V	Factory corrected	
AC-02	AI1 measured voltage 2	6.000 to 9.999	V	Factory corrected	
AC-03	AI1 displayed voltage 2	6.000 to 9.999	V	Factory corrected	
AC-12	AO1 target voltage 1	0.500 to 4.000	V	Factory corrected	
AC-13	AO1 measured voltage 1	0.500 to 4.000	V	Factory corrected	
AC-14	AO1 target voltage 2	6.000 to 9.999	V	Factory corrected	
AC-15	AO1 measured voltage 2	6.000 to 9.999	V	Factory corrected	

5.2 Monitoring Function Codes

✓ Group U0: Monitoring

Function Code	Parameter Name	Setting Range	Unit	Default	Commission
U0-00	Running frequency	-	Hz	-	
U0-01	Reference frequency	-	Hz	-	
U0-02	Bus voltage	-	V	-	
U0-03	Output voltage	-	V	-	
U0-04	Output current	-	A	-	
U0-05	Output power	-	kW	-	
U0-06	Output torque	-	%	-	
U0-07	DI state	-	N.A	-	
U0-08	DO state	-	N.A	-	
U0-09	AI1 voltage	-	V	-	
U0-10	Reserved	-	-	-	
U0-11	Reserved	-	-	-	
U0-12	Count value	-	N.A	-	
U0-13	Length value	-	N.A	-	
U0-14	Load speed	-	N.A	-	
U0-15	PID setting	-	N.A	-	
U0-16	PID feedback	-	N.A	-	
U0-17	PLC stage	-	N.A	-	
U0-18	Input pulse frequency	-	kHz	-	
U0-19	Feedback speed	-	Hz	-	
U0-20	Remaining running time	-	Min	-	
U0-21	AI1 voltage before correction	-	V	-	
U0-22	Reserved	-	-	-	
U0-23	Reserved	-	-	-	
U0-24	Linear speed	-	m/Min	-	
U0-25	Accumulative power-on time	-	Min	-	
U0-26	Accumulative running time	-	Min	-	
U0-27	Pulse input frequency	-	Hz	-	
U0-28	Communication setting value	-	%	-	
U0-29	Reserved	-	-	-	

Function Code	Parameter Name	Setting Range	Unit	Default	Commission
U0-30	Main frequency X	-	Hz	-	
U0-31	Auxiliary frequency Y	-	Hz	-	
U0-32	Viewing any register address value	-	N.A	-	
U0-33	Reserved	-	N.A	-	
U0-34	Motor temperature	-	°C	-	
U0-35	Target torque	-	%	-	
U0-36	Reserved	-	N.A	-	
U0-37	Power factor angle	-	°	-	
U0-38	Reserved	-	-	-	
U0-39	Reserved	-	-	-	
U0-40	Reserved	-	-	-	
U0-41	DI state visual display	-	N.A	-	
U0-42	DO state visual display	-	N.A	-	
U0-43	DI function state visual display 1	-	N.A	-	
U0-44	DI function state visual display 2	-	N.A	-	
U0-59	Current Frequency reference	-	%	-	
U0-60	Current running frequency	-	%	-	
U0-61	AC drive running state	-	N.A	-	