

Innovation  
+ Advance

Beyond Your Imagination

Contact Information of Agency

Shenzhen Inovance Technology Co., Ltd.  
Add.: Building E, Hongwei Industry Park, Liuxian Road,  
Baoheng No. 70 Zone, Bao'an District, Shenzhen  
Tel: (0755) 2979 9595  
Fax: (0755) 2961 9897  
Technical Support: (0755) 2961 9910  
Service Hotline: 400-777-1260  
<http://www.inovance.cn>

Copyright © Shenzhen Inovance Co., Ltd. All Rights Reserved.

## Inoflex

MD Series Inverter





## ABOUT INOVANCE



Shenzhen Inovance Technology Co., Ltd. is a public company (Stock code: 300124) which focuses on R&D, manufacture and sales of industrial automation control products, aiming to serve high-end equipment manufacturers. Inovance products include low-voltage inverters, integrated and special drivers, servo systems, PLCs and HMIs, etc. With strong R&D capabilities, we have established a leading position among all domestic companies in the industry since our establishment in 2003. We are now providing not only general but also customized products and solutions for our customers.

As a national high-tech corporate, we possess a number of patents that have been authorized or applied for, including 55 invention patents, 19 utility model patents and 17 design patents. Besides, we have mastered various core platform technologies, covering high-performance vector frequency conversion, PLCs, servo motors and permanent-magnet synchronous motors. Currently, we have a group of professional R&D experts dedicating to research and development of core platform technologies and new products.

## Service Network



- ◆ Shenzhen:
  - Shenzhen Inovance Investment Technology Co., Ltd.
  - Shenzhen Inovance Technology Co., Ltd.
  - Shenzhen Inovance Control Technology Co., Ltd. (focusing on PLC/HMI)
- ◆ Suzhou:
  - Suzhou Monarch Control Technology Co., Ltd. (focusing on elevator market)
  - Suzhou Inovance Technology Co., Ltd.
- ◆ Shenyang:
  - Shenyang Inovance Crane Control Technology Co., Ltd. (focusing on the crane market)

■ Office  
Set up the corporate headquarter in Shenzhen as well as branch companies in Suzhou, Shenyang and so on.  
29 offices throughout China  
More than 200 sales and service engineers  
147 authenticated distributors  
50 nationwide warrantee centers  
4 stock centers  
Quickly responding to customer needs

## Overall Product Solutions

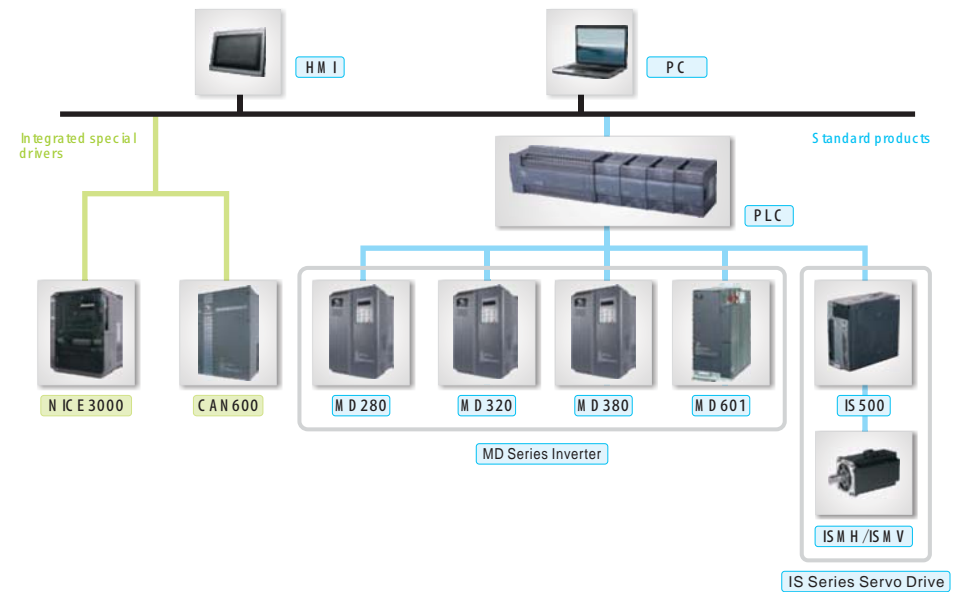

## MD Series Vector Inverter

Performance	Series	Target Market	Appearance
1) Parallel 8 unit 2) Four-in-one model 3) Parallel optical fiber 4) Torque constant control 5) Motor parameter temperature self-adaptive 6) Using the high-speed CAN bus to complete the data exchange among modules, realizing the parallel and auto-exit.	MD600 max:1.6MW	Oil drilling rig Lifting equipment Paper making Metallurgy	
1) Current vector control 2) Flexible expansion optional parts 3) Built-in tens kinds of non-standard function 4) Support both synchronous and asynchronous motor control	MD380 max:900kW	CNC manufacturing center Printing and packaging Lifting equipment Textile	
Dedicated inverter for tension control, which can meet a variety of situations with winding tension control	MD330 max:132kW	Tension winding and unwinding control	
Dedicated inverter for elevator control	ME320L max:900kW	Elevator control	
1) High-performance and multi-function 2) Multiple control mode selection 3) Flexible function 4) Good extension	MD320 MD300	Cable EPS Metal Plastics machinery Steel cord Textile dyeing and printing Air compressor	



## Overall Product Series



**MD320N**  
 Single-phase 220V 0.4~2.2kW  
 Three-phase 380V 0.7~450kW  
 Three-phase 4690V 132~560kW  
 (Parallel connection can up to 900kW)

**MD330N**  
 Single-phase 220V 0.4~2.2kW  
 Three-phase 380V 0.7~450kW

**MD300N**  
 Single-phase 220V 0.4~2.2kW  
 Three-phase 380V 0.7~90kW

**MD300A**  
 Single-phase 220V 0.2~2.2kW  
 Three-phase 380V 0.7~2.2kW

All products have passed CE certification.  
 All the products meet the ROHS standard.

## Perfect Performance

### Multiple control mode

⊙ V/F control  
 It has simple control, easy-to-use and constant speed, all of which can be used to the applications of that one inverter drives multiple motors and big inverters drive small inverters.  
 It is applicable to machine tools, centrifuge, drawing machine and injection molding machine, etc.

### ⊙ Sensor-less Vector Control \* SVC

It has stable speed precision and wide speed adjusting range, the adjusting range of MDXXXN series inverter is 1: 100. 150% of rated torque will be output when the 50 Hz of motor is up to 0.5Hz.  
 It is applicable to high-speed paper-making machinery, lifting equipment, elevators, etc.

### ⊙ Vector Control (VC)

The stable speed accuracy is more superior to V/F and SVC, speed adjusting range is wider than V/F or SVC. VC speed range ratio of MDXXXN series inverter is 1: 1000. 180% of rated torque can be output when MDXXXN series inverter is up to 0Hz under the VC mode, realizing torque control.

### Superior vector performance

- ⊙ Excellent torque performance at low frequency.
- ⊙ With zero-speed torque holding performance.
- ⊙ With good dynamic response features, it can give quick responses to the load disturb and external control commands.
- ⊙ High speed control precision, easily achieve high-precision synchronous control.
- ⊙ Direct torque control can easily achieve tension control.

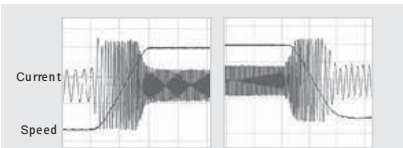

The features of speed-up and speed-down under the vector control mode

### Protect Torque Limit

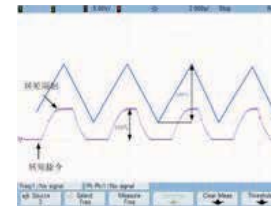

### Rotation Speed Tracking Restart

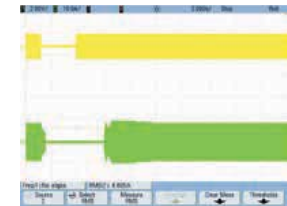

### Superior Response

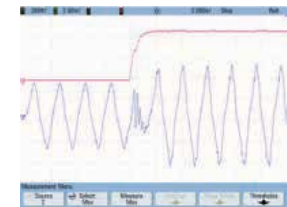
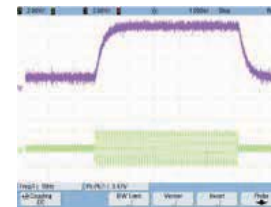

### Instruction Changes of Quick Tracking

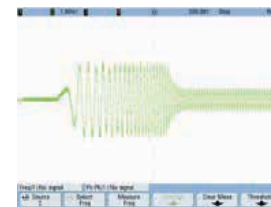

### Oscillation Suppression

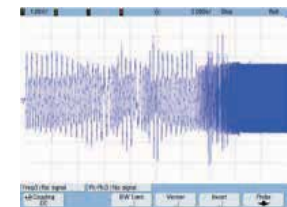

### Stall Over Current

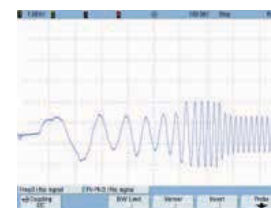

### High Startup Torque

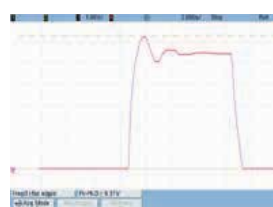
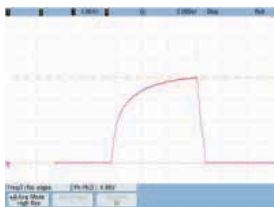
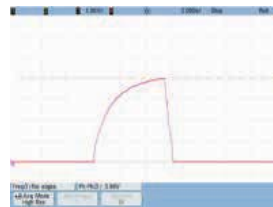
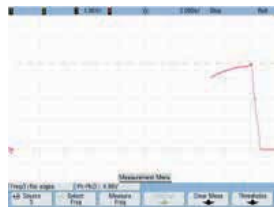



## Flexible Expansion Capability

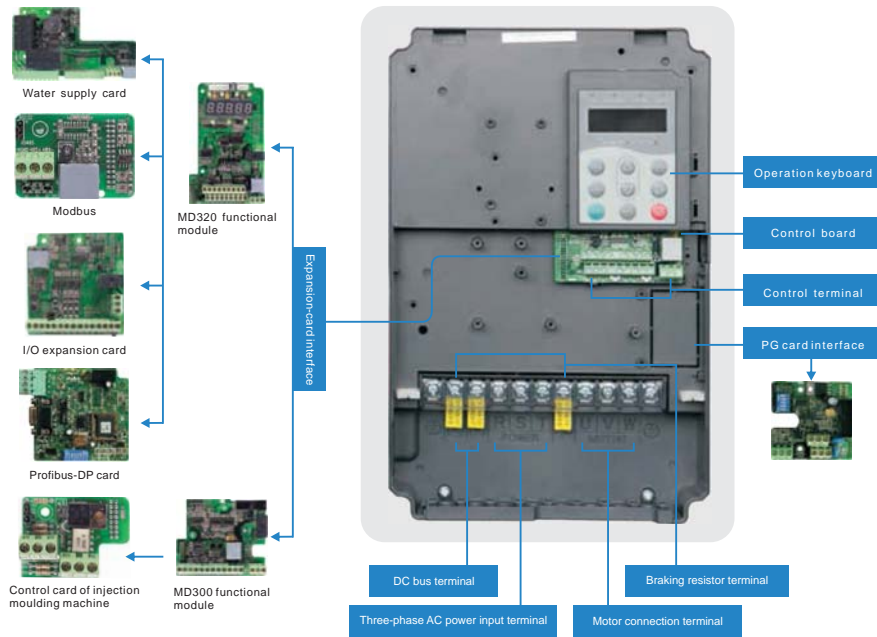

## Reliable Design

### Independent Air Ventilation Channel

- ☺ Independent air ventilation channels are employed in MD series inverter.
- ☺ The radiator can be installed in or outside the cabinet, which can meet the IP54 protection requirements mostly.
- ☺ Independent air ventilation channel would greatly improve the reliability when the inverter is applied in different industries such as textile, printing & dyeing, paper-making, wire-drawing and cement.

### Configured DC Reactors in 7.5kW and above modules

- ☺ To effectively increase the power factor of the input side.
- ☺ To improve the efficiency and thermal stability of the inverter.
- ☺ To effectively eliminate the impact on the inverter caused by the high frequency harmonics of the input side and to reduce the conduction and radiation.

### Broad Voltage Range Design

- ☺ MD series inverter can be operated normally within -15%~20% input voltage.

### Secure Self-check Function

- ☺ Provide secure self-check function to protect the equipment safety when inverter is power on.

### Perfect Protection Function

- ☺ 22 types of fault protection functions are provided to protect all devices ranging from the inverter to the motor.

### Reliable Lighting-protection Design

- ☺ There are lightning and over current protection devices inside the MD series inverter, effectively improving the self-protection function against the lightning.

### Specialized the Platform for Producing

- ☺ Processing technology featuring of dust-proof, moisture-proof and fungus-proof
- ☺ Specialized production line
- ☺ Standard operational specifications
- ☺ Perfect 5S management discipline
- ☺ Advanced process flow control
- ☺ Strict inspection system



## Easy to Use

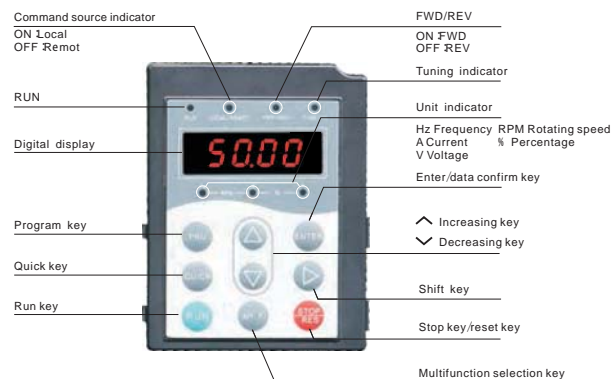

## User-friendly Interface

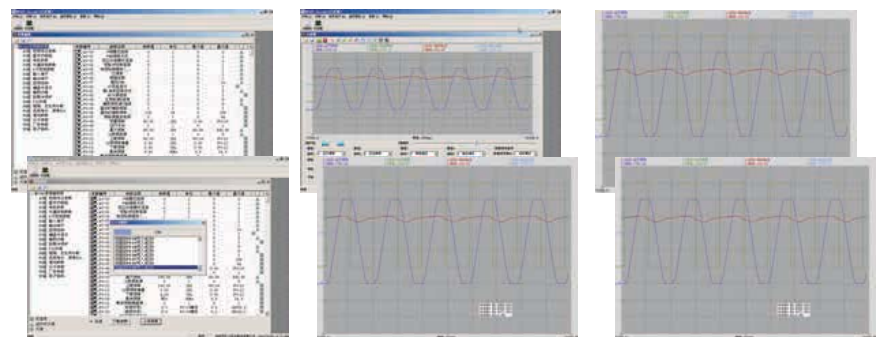



# MD Series Inverter

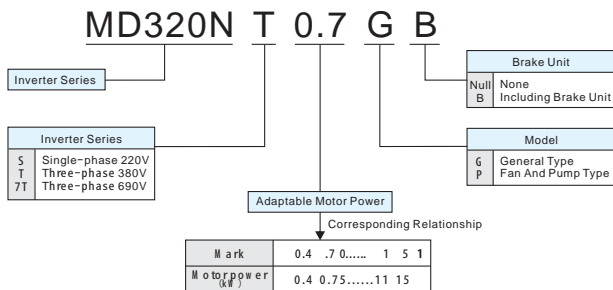

## Model and Technical Data

Inverter Model	Power Supply Capacity kVA	Input Current A	Output Current A	Adaptable Motor kW	HP
<b>Single-phase Power Supply: 200...240V, 50/60Hz</b>					
MD320N S0.4	1.0	5.4	2.3	0.4	0.5
MD320N S0.7	1.5	8.2	4.0	0.75	1
MD320N S1.5	3.0	14.0	7.0	1.5	2
MD320N S2.2	4.0	23.0	9.6	2.2	3
<b>Three-phase Power Supply: 380...480V, 50/60Hz</b>					
MD320N T0.7	1.5	3.4	2.1	0.75	1
MD320N T1.5	3.0	5.0	3.8	1.5	2
MD320N T2.2	4.0	5.8	5.1	2.2	3
MD320N T3.7	5.9	10.5	9.0	3.7	5
MD320N T5.5	8.9	14.6	13.0	5.5	7.5
MD320N T7.5	11.0	20.5	17.0	7.5	10
MD320N T11	17.0	26.0	25.0	11.0	15
MD320N T15	21.0	35.0	32.0	15.0	20
MD320N T18.5	24.0	38.5	37.0	18.5	25
MD320N T22	30.0	46.5	45.0	22	30
MD320N T30	40.0	62.0	60.0	30	40
MD320N T37	57.0	76.0	75.0	37	50
MD320N T45	69.0	92.0	91.0	45	60
MD320N T55	85.0	113.0	112.0	55	70
MD320N T75	114.0	157.0	150.0	75	100
MD320N T90	134.0	180.0	176.0	90	125
MD320N T110	160.0	214.0	210.0	110	150
MD320N T132	192.0	256.0	253.0	132	200
MD320N T160	231.0	307.0	304.0	160	250
MD320N T200	250.0	385.0	377.0	200	300
MD320N T220	280.0	430.0	426.0	220	350
MD320N T250	355.0	468.0	465.0	250	400
MD320N T280	396.0	525.0	520.0	280	450
MD320N T315	445.0	590.0	585.0	315.0	500
MD320N T355	500.0	665.0	650.0	355.0	*
MD320N T400	565.0	785.0	725.0	400.0	600
MD320N T450	630.0	883.0	820.0	450.0	*
<b>Three-phase Power Supply: 690V * 50/60Hz</b>					
MD320-7T132	192.0	170.0	150.0	132	200
MD320-7T160	231.0	200.0	175.0	160	250
MD320-7T200	250.0	235.0	215.0	200	300
MD320-7T220	280.0	247.0	245.0	220	350
MD320-7T250	355.0	265.0	260.0	250	400
MD320-7T280	396.0	305.0	299.0	280	450
MD320-7T315	445.0	350.0	330.0	315	500
MD320-7T355	500.0	382.0	374.0	355	—
MD320-7T400	565.0	435.0	410.0	400	600
MD320-7T450	630.0	490.0	465.0	450	—
MD320-7T500	700.0	595.0	550.0	500	700
MD320-7T560	630.0	605.0	575.0	560	750

## Technical Specifications

	Item	Specification
Basic Function	Maximum frequency	300Hz
	Carrier frequency	0.5kHz to 16kHz; The carrier frequency will be automatically adjusted according to the load characteristics.
	Input frequency resolution	Digital setting: 0.01Hz Analog setting: maximum frequency x0.1%
	Control mode	Open loop vector control (SVC) Close loop vector control (VC) V/F control
	Startup torque	G type: 0.5Hz/150% (SVC) ; 0Hz/180% (VC) P type: 0.5Hz/100%
	Speed adjustment range	1: 100 (SVC) 1 * 1000 * VC *
	Speed stabilization precision	0.5% (SVC) ±0.02% * VC *
	Torque control precision	±5% (VC)
	Overload capacity	G model: 150% rated current for 60s; 180% rated current for 1s. P model: 120% rated current for 60s; 150% rated current for 1s.
	Torque boost	Automatic torque hoist: manual torque hoist from 0.1% to 30.0%
	V/F curve	Three types: straight line, multiple point and square type
	Speed-up and Speed-down curve	Straight line or S curve speed-up and speed-down mode; four kinds of speed-up and speed-down time; speed-up and speed-down time ranges between 0.0s to 3000.0s.
	DC brake	DC brake frequency: 0.00Hz to maximum frequency; brake time: 0.0s to 36.0s, and brake current value: 0.0% to 100.0%.
	Jog control	Jog frequency range: 0.00Hz to 50.00Hz; jog acceleration/deceleration time: 0.0s to 3000.0s.
	Personalized Function	Simple PLC and MS speed running
Built-in PID		Easy to realize process-controlled close-loop control system.
Auto voltage regulation (AVR)		Keep constant output voltage automatically in case of change of mains voltage.
Torque limit and control		Limit the torque automatically and prevent frequent over current tripping during the running process; the close loop vector mode can implement torque control.
Peripherals self-detection upon power-on		Conduct safety detections on the peripherals upon power-on, including earth and short circuit detections.
Shared DC bus function		Realize the function that multiple inverters share the DC bus.
QUICK key		The user can freely define short-cut menus.
MF.K key		Programmable key: Select the command channel switching, forward and reverse rotations, jog operation.
Textile swing frequency control		Multiple triangular-wave frequency control function
Fixed-length control		Reference length control function
Timing control		Timing control function: Setting time range between 0h to 65535h.
Running command channel		Three types of channels: operation panel reference, control terminal reference and serial communication port reference. These channels can be switched in various modes.
Frequency source		There are totally ten types of frequency sources, such as digital reference, analog voltage reference, analog current reference, pulse reference and serial port reference. These frequency sources can be switched by various modes.
Auxiliary frequency source		There are ten types of auxiliary frequency sources. It can implement micro tuning and synthesis of auxiliary frequency.
Run		Input terminal
	Output terminal	There is one high-speed pulse output terminal (can be selected as open collector mode), with square wave output of 0kHz to 50kHz. It can output such physical parameters as setting frequency and output frequency. One digital output terminal (can be expanded to two) One relay output terminal (can be expanded to two) One analog output terminal (can be expanded to two), with optional 0/4mA to 20mA or 0/2V to 10V. It can realize the output of such physical parameters as setting frequency and output frequency.
Display and Keyboard Operation	LED display	Display the parameters.
	LCD display	Optional part, and can display operation contents Chinese/English.
	Parameter copy	Enables the parameter copy unit to copy the parameters quickly.
	Key locking and function selection	Lock the keys partially or completely and define the functional range of certain keys so as to prevent error operations.
Environment	Protection function	Implement power-on motor short-circuit detection, input/output phase loss protection, over current protection, over voltage protection, under voltage protection, over heat protection and overload protection.
	Optional parts	LCD operation panel, multifunctional I/O expansion card, braking components, communication card, extension card, PG card, water supply card, etc.
	Using Place	Indoor, and be free from direct sunlight, dust, corrosive gas, combustible gas, oil smoke, vapor, drip or salt.
	Altitude	Lower than 1,000 meters
	Ambient temperature	+0 °C Celsius to +40 °C Celsius (derated when used in the ambient temperature of 40 °C Celsius to 50 °C Celsius)
	Humidity	Less than 95%RH, without condensing
	Vibration	Less than 5.9 m/s (0.6g)
Storage temperature	-20 Celsius to +60 Celsius	



## Physical Appearance

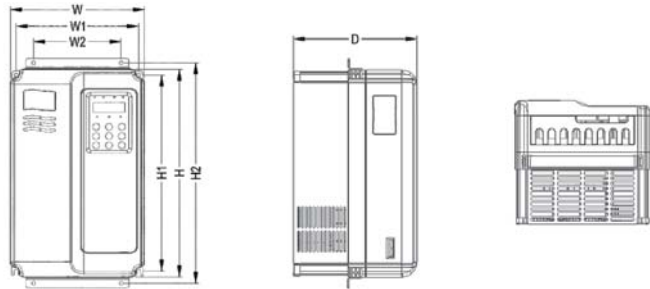
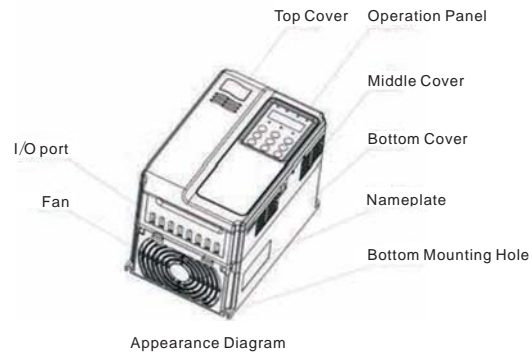

Schematic Diagram for Physical Dimensions and Mounting Dimensions of 0.4kW-5.5kW

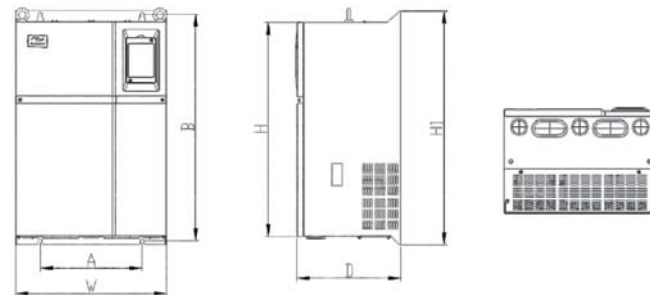

Schematic Diagram for Physical Dimensions and Mounting Dimensions of 18.5kW-450kW

※Adopt the top inlet-wire mode for the model above 110kW

## Mounting Dimensions

Inverter Model	Mounting Hole mm		Physical Dimensions mm				Diameter of Mounting Hole mm	Weight kg
	A	B	H	H1	W	D		
M D 320N S 0.4G M D 320N S 0.7G M D 320N S 1.5G M D 320N S 2.2G M D 320N T 0.7G B M D 320N T 1.5G B M D 320N T 2.2G B M D 320N T 3.7G B M D 320N T 5.5P B M D 320N T 5.5G B M D 320N T 7.5P B M D 320N T 7.5G B *	113	172	186	/	125	164	φ5.0	1.1
M D 320N T 11P B *	148	236	248	/	160	183	φ5.0	2.5
M D 320N T 11G B *								
M D 320N T 15P B *								
M D 320N T 15G B *								
M D 320N T 18.5G M D 320N T 22P M D 320N T 22G M D 320N T 30P M D 320N T 30G M D 320N T 37P M D 320N T 37G M D 320N T 45P M D 320N T 45G M D 320N T 55P M D 320N T 55G M D 320N T 75P M D 320N T 75G	190	305	322	/	208	192	φ6	6.5
M D 320N T 110P								
M D 320N T 110G								
M D 320N T 132P								
M D 320N T 132G M D 320N T 160P M D 320N T 160G M D 320N T 200P M D 320N T 200G M D 320N T 220P M D 320N T 220G M D 320N T 250P M D 320N T 250G M D 320N T 280P M D 320N T 280G M D 320N T 315P M D 320N T 315G M D 320N T 355P M D 320N T 355G	235	447	432	463	285	228	φ8	20
M D 320N T 110P								
M D 320N T 132P								
M D 320N T 160P								
M D 320N T 160G M D 320N T 200P M D 320N T 200G M D 320N T 220P M D 320N T 220G M D 320N T 250P M D 320N T 250G M D 320N T 280P M D 320N T 280G M D 320N T 315P M D 320N T 315G M D 320N T 355P M D 320N T 355G	260	580	549	600	385	265	φ10	32
M D 320N T 110P								
M D 320N T 132P								
M D 320N T 160P								
M D 320N T 160G M D 320N T 200P M D 320N T 200G M D 320N T 220P M D 320N T 220G M D 320N T 250P M D 320N T 250G M D 320N T 280P M D 320N T 280G M D 320N T 315P M D 320N T 315G M D 320N T 355P M D 320N T 355G	343	678	660	700	473	307	φ10	47
M D 320N T 110P								
M D 320N T 132P								
M D 320N T 160P								
M D 320N T 160G M D 320N T 200P M D 320N T 200G M D 320N T 220P M D 320N T 220G M D 320N T 250P M D 320N T 250G M D 320N T 280P M D 320N T 280G M D 320N T 315P M D 320N T 315G M D 320N T 355P M D 320N T 355G	449	905	880	930	579	375	φ10	90
M D 320N T 110P								
M D 320N T 132P								
M D 320N T 160P								
M D 320N T 160G M D 320N T 200P M D 320N T 200G M D 320N T 220P M D 320N T 220G M D 320N T 250P M D 320N T 250G M D 320N T 280P M D 320N T 280G M D 320N T 315P M D 320N T 315G M D 320N T 355P M D 320N T 355G	420	1030	983	1060	650	377	φ12	130
M D 320N T 110P								
M D 320N T 132P								
M D 320N T 160P								
M D 320N T 160G M D 320N T 200P M D 320N T 200G M D 320N T 220P M D 320N T 220G M D 320N T 250P M D 320N T 250G M D 320N T 280P M D 320N T 280G M D 320N T 315P M D 320N T 315G M D 320N T 355P M D 320N T 355G	520	1300	1203	1358	800	400	φ14	200
M D 320N T 110P								
M D 320N T 132P								
M D 320N T 160P								
M D 320N T 160G M D 320N T 200P M D 320N T 200G M D 320N T 220P M D 320N T 220G M D 320N T 250P M D 320N T 250G M D 320N T 280P M D 320N T 280G M D 320N T 315P M D 320N T 315G M D 320N T 355P M D 320N T 355G	320	1166	1090	1192	440	310	φ10	90
M D 320-7T 132G H								
M D 320-7T 160P H								
M D 320-7T 160G H								
M D 320-7T 200P H M D 320-7T 200G H M D 320-7T 220P H M D 320-7T 220G H M D 320-7T 250P H M D 320-7T 250G H M D 320-7T 280P H M D 320-7T 280G H M D 320-7T 315P H M D 320-7T 315G H M D 320-7T 355P H M D 320-7T 355G H	420	1030	983	1060	650	377	φ12	130
M D 320-7T 132G H								
M D 320-7T 160P H								
M D 320-7T 160G H								
M D 320-7T 200P H M D 320-7T 200G H M D 320-7T 220P H M D 320-7T 220G H M D 320-7T 250P H M D 320-7T 250G H M D 320-7T 280P H M D 320-7T 280G H M D 320-7T 315P H M D 320-7T 315G H M D 320-7T 355P H M D 320-7T 355G H	520	1300	1203	1358	800	400	φ14	200
M D 320-7T 132G H								
M D 320-7T 160P H								
M D 320-7T 160G H								
M D 320T 110G H M D 320T 110P H M D 320T 132G H M D 320T 132P H M D 320T 160G H M D 320T 160P H M D 320T 200G H M D 320T 200P H	320	1166	1090	1192	440	310	φ10	90
M D 320T 110G H								
M D 320T 132G H								
M D 320T 160G H								

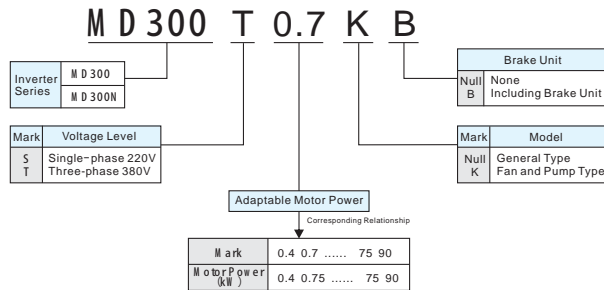

## Model and Technical Data

Inverter Model	Input Voltage	Power Supply Capacity (kVA)	Input Power (A)	Output Power (A)	Adaptable Motor (kW)
M D 300N S 0.4	Single-phase 220V Range: -15% ~ 20%	1.0	5.4	2.3	0.4
M D 300N S 0.7		1.5	8.2	4.0	0.75
M D 300N S 1.5		3.0	14.2	7.0	1.5
M D 300N S 2.2		4.0	23.0	9.6	2.2
M D 300N T 0.7	Three-phase 380V Range: -15% ~ 20%	1.5	3.4	2.1	0.75
M D 300N T 1.5		3.0	5.0	3.8	1.5
M D 300N T 2.2		4.0	5.8	5.1	2.2
M D 300N T 3.7		5.9	10.5	9.0	3.7
M D 300N T 5.5		8.9	14.6	13.0	5.5
M D 300N T 7.5		11.0	20.5	17.0	7.5
M D 300N T 11		17.0	26.0	25.0	11.0
M D 300N T 15		21.0	35.0	32.0	15.0
M D 300N T 18.5		24.0	38.5	37.0	18.5
M D 300N T 22		30.0	46.5	45.0	22.0
M D 300N T 30		40.0	62.0	60.0	30.0
M D 300N T 37		57.0	76.0	75.0	37.0
M D 300N T 45		69.0	92.0	91.0	45.0
M D 300N T 55		85.0	113.0	112.0	55.0
M D 300N T 75		114.0	157.0	150.0	75.0
M D 300N T 90		134.0	180.0	176.0	90.0

## Technical Specifications

Item	Specification	
Basic Function	Maximum frequency	300Hz
	Carrier frequency	0.5kHz to 16kHz: The carrier frequency will be automatically adjusted according to the load characteristics.
	Input frequency resolution	Digital setting: 0.01Hz Analog setting: maximum frequency x0.1%
	Control mode	Open loop vector control (SVC) V/F control
	Startup torque	0.5Hz/150%
	Speed adjustment range	1: 100 ( SVC)
	Speed stabilization precision	±0.5% ( SVC)
	Overload capacity	150% rated current for 60s. 180% rated current for 1s.
	Torque boost	Automatic torque hoist; manual torque hoist 0.1% to 30.0%
	V/F curve	Two types: straight line and square type
	DC brake	DC brake frequency: 0.00Hz to maximum frequency; Brake time: 0.0s to 36.0s, and brake value: 0.0% to 100%.
	Jog control	Jog frequency range: 0.00Hz-50.00Hz. Jog speed-up/speed-down time: 0.0s-3000.0s
	Personalized Function	Peripherals self-detection upon power-on
Shared DC bus function		Realize the function that multiple inverters share the DC bus.
MF.K key		Programmable key: Select the command channel switching/forward and reverse rotations/jog operation.
Running command channel		Two channels: Operation panel reference and control terminal reference.
I/O Features	Frequency source	Three types of channels: operation panel reference, control terminal reference and serial communication port reference. These channels can be switched in various operations.
	Auxiliary frequency source	implement micro tuning and synthesis of auxiliary frequency.
	Input terminal	Four digital input terminals, one of which can be used as high-speed pulse input. There are two analog input terminals, one of which can be used only as voltage input, while the other can be used as voltage or current input.
Output terminal	One digital output terminal One relay output terminal One analog output terminal. It can realize the output of such physical parameters as setting frequency and output frequency.	
Display and Keyboard Operation	LED display	Display setting frequency, output frequency, output voltage, and output current.
Protection Function		Implement power-on motor short-circuit detection, input/output phase loss protection, over current protection, over voltage protection, under voltage protection, over heat protection and overload protection.
Using Place		Indoor, and be free from direct sunlight, dust, corrosive gas, combustible gas, oil smoke, vapor, drip or salt.
Environment	Protection grade	IP20
	Altitude	Lower than 1000m, derated when higher than 1000 m
	Ambient temperature	-10 °C to +40 °C (derated when used in the ambient temperature of 40 °C to 50 °C)
	Humidity	Less than 95% RH, without condensing
	Vibration	Less than 5.9m/s <sup>2</sup> (0.6g)
	Storage temperature	- 20°C ~ +60°C
Pollution level	Level two Refer to IEC61800-5-1 • 4.2.6 for details)	



## Physical Appearance

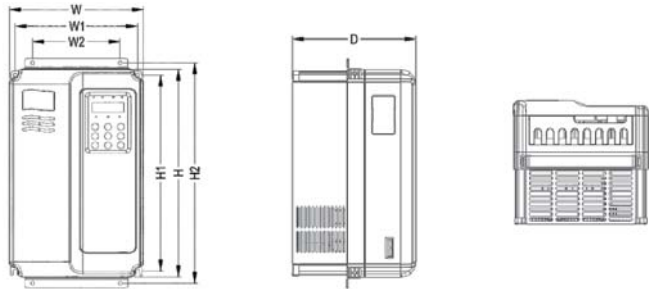
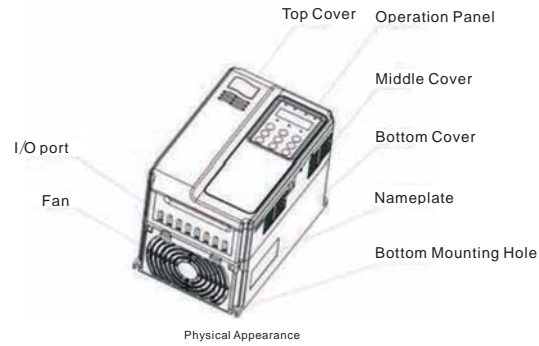

Schematic Diagram for Physical Dimensions and Mounting Dimensions of 0.4kW-15kW



Schematic Diagram for Physical Dimensions and Mounting Dimensions of 18.5kW-90kW

## Mounting Dimensions

Model	Mounting Hole mm		Physical Dimensions mm				Diameter of Mounting Hole mm	Weight kg
	A	B	H	H1	W	D		
M D 300N S0.4	113	172	186	/	125	164	φ5.0	1.1
M D 300N S0.7								
M D 300N S1.5								
M D 300N S2.2								
M D 300N T0.7								
M D 300N T1.5	148	236	248	/	160	183	φ5.0	2.5
M D 300N T2.2								
M D 300N T3.7								
M D 300N T5.5	190	305	322	/	208	192	φ6	6.5
M D 300N T7.5								
M D 300N T11								
M D 300N T15	235	447	432	463	285	228	φ8	20
M D 300N T18.5								
M D 300N T22								
M D 300N T30								
M D 300N T37								
M D 300N T45	260	580	549	600	385	265	φ10	32
M D 300N T55								
M D 300N T75								
M D 300N T90	343	678	660	700	473	307	φ10	47

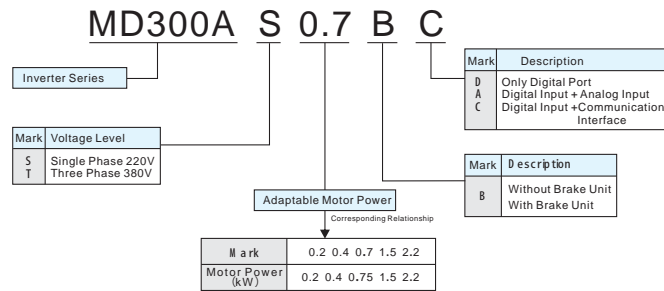

## Model and Technical Data

Inverter Model	Input Voltage	Rated Power Supply Capacity (kVA)	Rated Input Current (A)	Rated Output Current (A)	Adaptable Motor (kW)
MD300A-S0.2BA	Single phase 220V Range: -15% ~ 20%	0.6	3.2	1.2	0.2
MD300A-S0.4BA		1.0	5.4	2.3	0.4
MD300A-S0.7BA		1.5	8.2	4.0	0.75
MD300A-S1.5BA		3.0	14.2	7.0	1.5
MD300A-S2.2BA		4.0	23.0	9.6	2.2
MD300A-T0.7BA	Three phase 380V Range: -15% ~ 20%	1.5	3.4	2.1	0.75
MD300A-T1.5BA		3.0	5.0	3.8	1.5
MD300A-T2.2BA		4.0	7.0	5.1	2.2

### Physical Appearance of Inverter

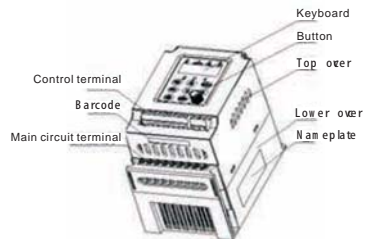

### Dimensions of Mounting Hole

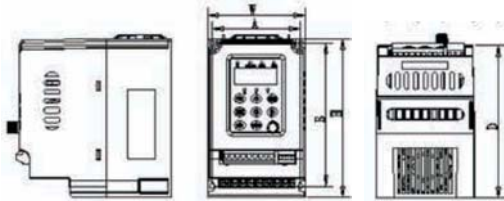

### Mounting Dimensions

Inverter Model	Adaptable Motor (kW)	A	B	H	W	D	Diameter	Weight kg
MD300A S0.2BA	Single phase 220V	78	126	139.5	86	134	4.2	0.9
MD300A S0.4BA								
MD300A S0.7BA								
MD300A S1.5BA								
MD300A S2.2BA								
MD300A T0.7BA	Three phase 380V	78	126	139.5	86	134	4.2	0.9
MD300A T1.5BA								
MD300A T2.2BA								

## Technical Specifications

Item	Specification	
Basic Parameters	Maximum output frequency	3200Hz
	Carrier frequency	0.5 kHz~16kHz;the carrier frequency will be automatically adjusted according to the temperature rise.
	Input frequency resolution	Digital setting: 0.01Hz Analog setting: maximum frequency ×0.1%
	Control mode	Open loop vector control (SVC) and V/F control
	Startup torque	0.5Hz/150%
	Adjustment range	1: 100 ( SVC)
	Speed stabilization precision	±0.5% ( SVC)
	Overload capacity	150% rated current for 60s;180% rated current for 1s
	Torque hoist	Automatic torque hoist; manual torque hoist 0.1% to 30.0%
	V/F curve	Two types: straight line and square type V/F curve
	DC brake	DC brake frequency: 0.00Hz to maximum frequency; brake time: 0.0s to 36.0s, and brake current value: 0.0% to 100.0%.Built-in brake unit.
	Jog control	Jog frequency range: 0.00Hz to 50.00Hz; jog acceleration/deceleration time: 0.0s to 3000.0s.
	Personalized Function	Shared DC bus function
Running command channel		Three types of channels: operation panel control, control terminal control and communication control(optional).
I/O Features	Frequency source	There are six frequency source:Panel potentiometer reference, digital reference, analog voltage/current reference (optional), pulse reference and communication reference (optional).
	Auxiliary frequency source	Implement micro tuning and synthesis of auxiliary frequency.
	Input terminal	4 digital input terminals, one of which can be high speed pulse input(maximum input frequency is 50kHz).Select one of the following added function terminals when placing the order. A: One analog input terminal, it can select voltage (DC 0V~ 24V or 0V~ 10V)or current (0mA~ 20mA) input. B: 485 communication terminal
	Output terminal	One digital output terminal One fault relay output terminal One analog output AO Output voltage range: 0~10VDC
Display and Keyboard Operation	LED display	Display seven types of parameters including setting frequency, output frequency, output voltage and output current, etc.
Protection function		Implement power-on motor short-circuit detection, input/output phase loss protection, over current protection, over voltage protection, under voltage protection, over heat protection and overload protection.
Using place		Indoor, and be free from direct sunlight, dust, corrosive gas, combustible gas, oil smoke, vapor, drip or salt.
Environment	Altitude	Lower than 1000m
	Ambient temperature	-10 °C to +40 °C (derated when used in the ambient temperature of 40 °C Celsius to 50 °C Celsius)
	Humidity	Less than 95%RH,without condensing
	Vibration	Less than 5.9m/s( 0.6g)
	Storage temperature	- 20°C~ +60°C

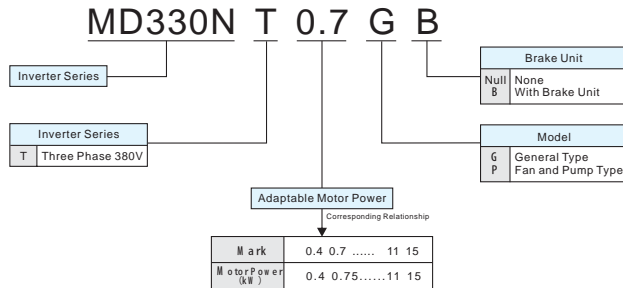

## Features

- On the basis of Inovance MD320N series inverter, MD330N series inverter for tension control is a high-performance vector control inverter which adds the winding and unwinding functional modules. MD330N integrates the rich winding mode to meet the requirements of the winding and unwinding tension control in all cases, simple the control system of machinery electrical devices.
- MD330N has the closed-loop and open loop tension control mode, the user can choose flexibly according to different control requirements, external environment and configuration. There is also a horizontal speed control mode. Compared with the traditional linear speed, the closed-loop system is more stable, which must be used in the applications that should use the winding and unwinding to control linear speed.
- MD330N coil diameter calculation has multiple coil diameter calculation modes, which can attain the accurate coil diameter.
- MD330N has complete inertia compensation modules, so that it can reduce the tension impact for the speed-up and speed-down system under the tension open loop (torque control) mode.
- MD330N has two sets of PID parameters, which can be matched via the coil diameter or linear speed and changed linear variation between high and low ends, so the system is stable.
- MD330N can control the tension taper, directly control the changes of the tension taper in the open-loop mode or pressure sensor closed-loop mode. In the swing link sensor tension closed-loop control mode, the tension taper can be controlled via the taper analog output to control proportional valve.
- MD330N taper tension has two modes, including the curve tension taper mode and the multi-fold point of the linear tension taper mode, a variety of materials and processes have can access to good winding and unwinding effect.
- MD330N has the control logic of automatic spool changing, simplify the non-stop spool changing.
- Rich terminal control functions of MD330N can simplify the winding and unwinding, as well as switching between speed and tension. MD330N of dyeing machine can still well control the tension and linear constant speed without tension sensors and linear speed sensors.

## Model and Technical Data

Inverter Model	Input Voltage	Power Supply Capacity (kVA)	Input Current (A)	Output Current (A)	Adaptable Motor (kW)
MD330N S0.4	Single-phase 220V Range: -15% ~ 20%	1.0	5.4	2.3	0.4
MD330N S0.7		1.5	8.2	4.0	0.75
MD330N S1.5		3.0	14.2	7.0	1.5
MD330N S2.2		4.0	23.0	9.6	2.2
MD330N T0.7	Three-phase 380V Range: -15% ~ 20%	1.5	3.4	2.1	0.75
MD330N T1.5		3.0	5.0	3.8	1.5
MD330N T2.2		4.0	5.8	5.1	2.2
MD330N T3.7		5.9	10.5	9.0	3.7
MD330N T5.5		8.9	14.6	13.0	5.5
MD330N T7.5		11.0	20.5	17.0	7.5
MD330N T11		17.0	26.0	25.0	11.0
MD330N T15		21.0	35.0	32.0	15.0
MD330N T18.5		24.0	38.5	37.0	18.5
MD330N T22		30.0	46.5	45.0	22.0
MD330N T30		40.0	62.0	60.0	30.0

※PG card of 0.4~2.2kW is outside-hanging.  
 ※MD330N series inverter of more than 30kW can be provided according to customer needs.  
 ※Refer to MD320N for mounting dimensions.  
 ※Technical specifications are the same as that of MD320N.

## Tension Control

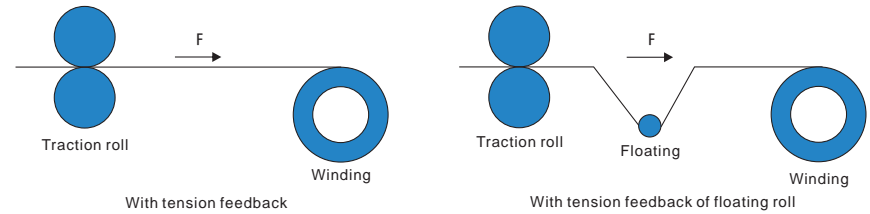

There are two methods for the tension control, one of which can control the output torque of the motor, the other can control the rotation speed of the motor. MD330 design tension control modes are corresponding to the two methods.

- Open-loop torque control mode  
 Open loop means no tension feedback signals, the inverter can use the output frequency or torque to control the system, and it is not relevant to the open-loop and close-loop vector. Torque control mode means the inverter can control the motor torque instead of the frequency. The output frequency changes automatically along with the material speed.  
 From the formula  $F=T/R$  (F refers to material tension, T refers to winding shaft torque, R refers to the radius of the winding), it can be seen that if the torque of the winding shaft can be adjusted based on changes in the roll diameter, the tension of the material can be controlled. This is the proof that open loop torque mode is able to control tension.  
 Under the closed loop vector control, MD series inverter (sensor vector control) can accurately control the motor output torque. This control mode requires the addition of an encoder (frequency converters must have a PG card).

Open-loop torque mode for function modules:

- Tension setting: In actual use, the set value for tension should correspond to the actual needs depending on the material and the forming of the roll and should be set by the user. In order to improve the roll formation during winding, the tension tapering can keep the tension while the diameter increases.
- Diameter Calculation: This can be used to calculate or attain the diameter. Use the linear speed input function if using the linear speed to calculate the diameter. Use the thickness calculation to calculate the related parameters if using the thickness calculation.
- Torque compensation: Some part of the output torque can overcome the rotational inertia of the roll when accelerating/decelerating. The inertial compensator in the frequency converter can use the appropriate parameter settings to automatically carry out torque compensation based on the rate of change in speed. This allows for stable tension in the system during speeding up/down. Frictional compensation can overcome the influence of system resistance on the creation of tension.

2. Closed-loop speed control mode

Closed loop means use the tension detection feedback signal to form the closed loop adjustment, the speed control mode means the inverter can adjust the output frequency according to the feedback signal and then achieve control the system. Under this mode, the inverter can work in any of the three modes, which are the speed sensorless vector control, speed sensor vector control and V/F control.  
 The principle of this control mode is to calculate a match frequency setting value f1, and then take the PID operation to get a frequency adjusted value f2 via the tension feedback, the maximum frequency output is  $f=f1+f2$ . f1 can match the winding(unwinding)roll linear speed to the material speed, the part f2 can control after the adjustment and then resolve the contradictions between the stability and responsiveness of the closed-loop control.  
 Under this mode, tension setting is disabled, set the system target value in the reference source of FA-00PID, the control result is to make the feedback signal in the reference value of PID. When take the position signal (tension swing link and floating roll) as the feedback, changing the setting value (PID given) may not be able to change the actual tension, we can change the configuration on the machinery to change the tension, such as the counterweight for the tension swing link or floating roll.

Closed-loop speed mode for the function modules:

- PID: set mainly in group FA, the second group PID parameters in group FH can play an auxiliary effect. After the other parts are set correctly, the final control effect should adjust the PID parameters.
- Linear speed input: this part is very important, which has two functions. One is calculating the matching frequency of the inverter via the linear speed; the other is calculating the diameter via the linear speed.
- Diameter calculation: calculate the actual diameter. The inverter can get the matching frequency after getting the linear speed and actual diameter. When using the linear speed to calculate the diameter, if there is deviation between the calculated diameter and actual diameter. It means there is a deviation for linear speed input which can be corrected by the diameter calculation. Note that the matching value which is calculated by the linear speed and diameter is the actual output frequency of the inverter, the running frequency which is calculated by the linear speed and running frequency is the actual output frequency, therefore, there is no contradiction here.
- The second group of PID parameters: Use the second group of PID parameters when one group of PID parameters can not meet the whole control effect. For example, the better effect can be realized via adjusting the first PID parameter at small roll while the second PID parameter at the full capacity.

## Wiring Diagram

Wiring Diagram of MD320N

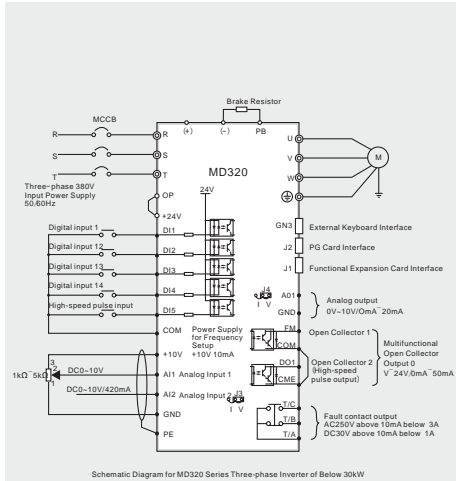
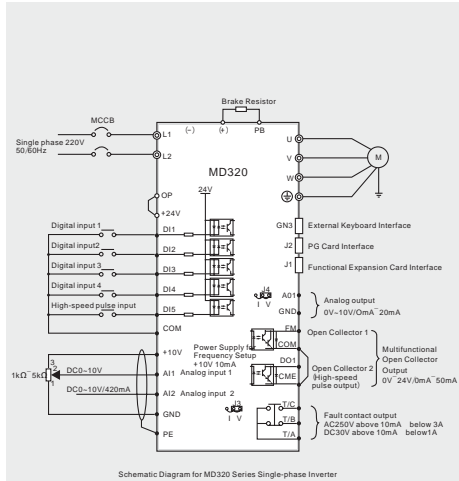

Wiring Diagram of MD300A

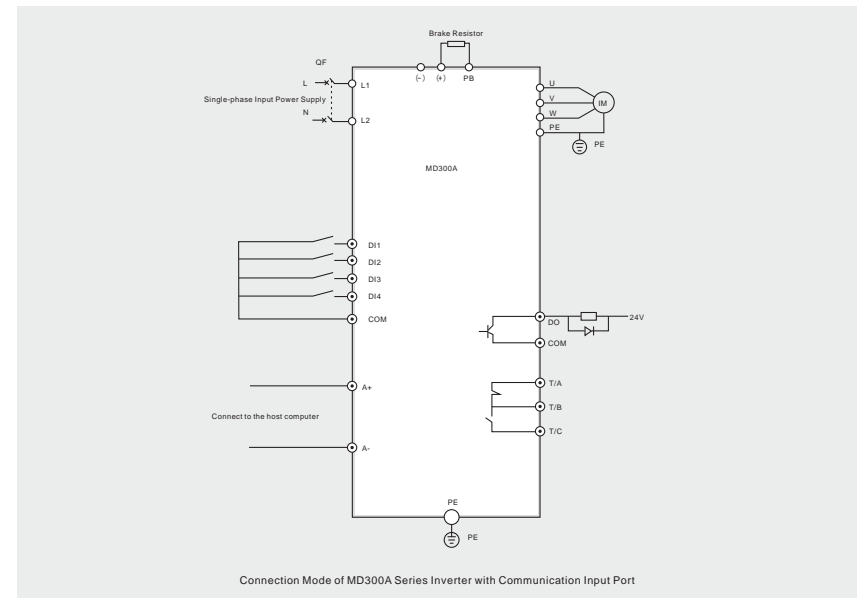
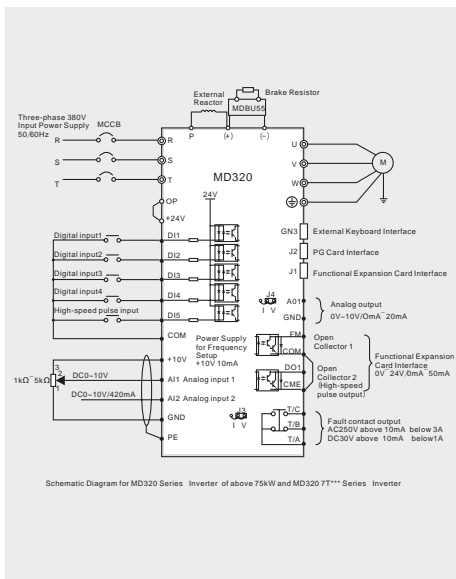
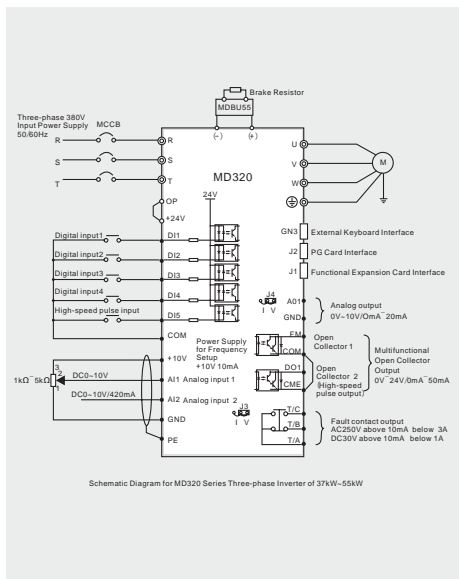
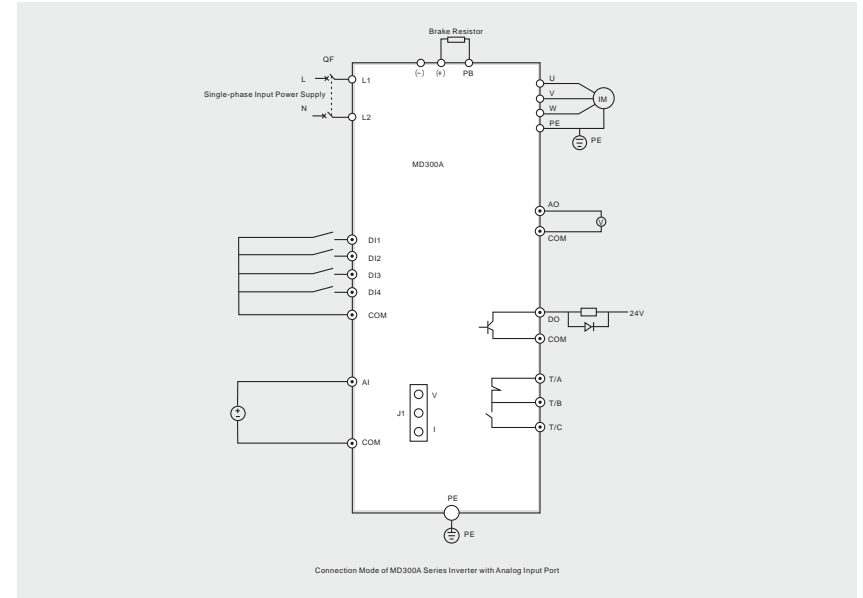

※The connection mode of MD330 and MD300 are the same as that of MD320.



## Optional Parts

Image	Model	Description
	MD32IO Expansion Card	MD32IO card is I/O expansion card launched by Shenzhen Inovance Technology Co., Ltd to support the use of MD320 series inverter. It can add five digital inputs, one analog voltage signal input, one relay signal output, one digital signal output and one analog signal output. Meanwhile, IO expansion card has communication function and supports RS-485 communication mode.
	MD320-485 Communication Card	Communication card is divided into RS-232 communication interface card and RS-485 communication interface card and serves as the expansion card special for the MD320 inverter of Shenzhen Inovance Technology Co., Ltd, which can provide RS-232 and RS-485 communication modes respectively. Their electric parameters comply with the international standard, and the user can select RS-232 communication card or RS-485 communication card according to the actual needs so as to implement the function of controlling the inverter running and parameter setting in the serial port mode. Refer to MD320 Serial Communication Protocol for the details regarding the communication card.
	MD32PFS Profibus	MD32PFS complies with the international standard of PROFibus, which can support the use of Inovance inverters, realizing the real fieldbus control.
	MD32PG General-purpose PG Card	This PG card is connected to the adapter of Inovance inverter as differential encoder. It can be applied in the situation with synchronous motor and induction motor close-loop control.
	MD32WS Water Supply Card	MD32WS multi-pump water supply control card which is installed in MD320 series inverter can implement more pump constant pressure water supply. It contains the ordinary life water and fire protection water control modes, which can complete the variable frequency pump, power pump, sleep pump, sewage pump and fire pump as well as the automatic switching logic, while realizing multi-period constant pressure water supply, sleep control, sewage control, timing for pump, pump failure judgment, reports and auto-exit logic.
	MD30IN Injection Molding Machine Card	MD30IN card is the injection moulding machine that launched by Shenzhen Inovance Technology Co., Ltd to support the use of MD300 series inverter. It can directly enter 01A (via AICOM Terminal) DC current signal or 024V (via AVCOM Terminal) DC voltage signal.
	MDBU External Brake Unit	In order to improve braking capacity of the inverter and drive the motor quickly, the braking unit is used to consume the energy generated in the braking process. The model above 37kW can be the optional configuration.
	MDFB Energy Feedback Unit	MDFB series energy feedback unit can feed the energy which is generated and input to the inverter during the braking process back to the power grid. While satisfying the effective braking of the inverter, there are more than 95% of the regenerated electrical energy can be recycled. The product has functions including the over-temperature, over voltage and over current, with the features including the low noise, low harmonic pollution, and high power factor and so on.
	External LED Operation Keyboard	External LED display and operation keyboard of RJ45 interface

## Lectotype of Brake Components

### Lectotype of Brake Components

The following table provides data for reference, and the user can select different resistance and power according to the actual needs (but the resistance shall not be lower than the recommended value, and the power may be higher than the recommended value). The selection of brake resistor shall be determined in accordance with the power generated by the motor in the actual application system and is associated with the system inertia, speed-down time and energy of potential load. Thus, the user needs to select based on the actual needs. The higher the system inertia, the shorter the speed-down time required, and more frequent the brake is, and then it needs to select higher power and lower resistance value for the brake resistor.

### Selection of resistance value

Renewable electric energy consumption is almost the braking resistor when braking.

According to the formula  $U^2/R=P_b$ ,

U refers to stable braking system of brake voltage. (Different system has different brake voltage. The system 380VAC generally selects 700V).

$P_b$  represents the braking power.

### Selection of Braking Resistor Power

Theoretically, the braking resistor power is consistent with braking power.

According to the formula:  $0.7^2 \cdot P_r = P_b \cdot D$

$P_r$  refers to the resistor power

D refers to braking frequency. (Which is the regeneration process in the proportion of the entire working process).

Elevator: 20%~30% Winding and unwinding: 20%~30% Centrifuge: 50%~60% Occasional brake load: 5% Generally select 10%

Brake Components Prototyping Table of MD 320 Series Inverter

Inverter Model	Recommended Power of Brake Resistor	Recommended Resistance Value of Brake Resistor	Braking Unit	Remarks
MD320S0.4	80W	≥200Ω	Built-in, optional	The letter B is attached behind the inverter model.
MD320S0.7	80W	≥150Ω		
MD320S1.5	100W	≥100Ω		
MD320S2.2	100W	≥70Ω		
MD320T0.7	150W	≥300Ω	Built-in as standard	No special specification
MD320T1.5	150W	≥220Ω		
MD320T2.2	250W	≥200Ω		
MD320T3.7	300W	≥130Ω		
MD320T5.5	400W	≥90Ω		
MD320T7.5	500W	≥65Ω		
MD320T11	800W	≥43Ω		
MD320T15	1000W	≥32Ω		
MD320T18.5	1300W	≥25Ω	Built-in, optional	The letter B is attached behind the inverter model.
MD320T22	1500W	≥22Ω		
MD320T30	2500W	≥16Ω		
MD320T37	3.7 kW	≥16.0Ω	Externally connected	MDBU-35-B
MD320T45	4.5 kW	≥16Ω		MDBU-35-B
MD320T55	5.5 kW	≥8Ω		MDBU-70-B
MD320T75	7.5 kW	≥8Ω		MDBU-70-B
MD320T90	4.5 kW×2	≥80×2		MDBU-70-B×2
MD320T110	5.5 kW×2	≥80×2		MDBU-70-B×2
MD320T132	6.5 kW×2	≥80×2		MDBU-70-B×2
MD320T160	16kW	≥2.5Ω		MDBU-210-B
MD320T200	20 kW	≥2.5Ω		MDBU-210-B
MD320T220	22 kW	≥2.5Ω		MDBU-210-B
MD320T250	12.5 kW×2	≥2.5Ω×2		MDBU-210-B×2
MD320T280	14kW×2	≥2.5Ω×2		MDBU-210-B×2
MD320T315	16kW×2	≥2.5Ω×2		MDBU-210-B×2
MD320T355	17kW×2	≥2.5Ω×2		MDBU-210-B×2
MD320T400	14 kW×3	≥2.5Ω×3		MDBU-210-B×3
MD320T450	15kW×3	≥2.5Ω×3		MDBU-210-B×3

※Note: x2 refers to two braking unit paralleled with their respective brake resistor; the meaning of x3 is the same with x2.

※Refer to the above table for the braking resistor selection of MD300N, MD330N and MD300A series inverter.