

## H0U Series PLC User Manual

Thank you for purchasing the H0U series programmable logic controller (PLC) independently developed by Inovance Control Technology Co., Ltd. Read the manual carefully to be familiar with the product features and be able to use the product safely.

This manual describes the specification, features and usage of the H0U series PLC. For the developing environment and design method of user programs, see the H0U Series PLC Programming Manual and the H1U/H2U Series PLC Instruction & Programming Manual issued by Inovance.

The H0U series PLC has the following features:

- It integrates PLC and TOD programs and allows programming of control logics & display interface.
- It supports all the instructions of the H1U and the CAN communication protocol.
- It reaches the user memory space of 8k steps and the maximum capacity of the user TOD programs of 56 KB.
- It has two independent communication ports (COM1, COM2), making it act as master or slave.
- It supports 6-channel high-speed inputs and 2-channel high-speed outputs (only transistor output).
- It supports display in both simplified Chinese and English, and switchover between the two languages online.
- It has a total of 25 functional keys, whose functions can be defined freely.
- It allows you to download the PLC and TOD programs via AutoShop and HTodEditor.

### Safety Information and Precautions

#### In Design



Provide a safety circuit outside the PLC in the application so that the control system can still work safely even if external power failure or PLC fault occurs. Take the following aspects into considerations in the design:

- In the external circuit of the PLC, an emergency stop circuit, a protection circuit, an interlock circuit of forward/reverse rotation operation, and position upper/lower limit interlock circuit are necessary to prevent equipment damage
- To ensure safe running of the equipment, external protection circuit and safety mechanism must be designed for the output signals that may cause serious accidents.
- When the CPU of the PLC detects an abnormality of its own system, all outputs may

be cut off. When a failure occurs on the controller circuit, related outputs may be out of control. Thus, an appropriate external circuit must be designed to ensure normal running of the equipment.

- When the output units such as relay or transistor are damaged, related outputs will be out of control and be continuously kept ON or OFF. Return the AC drive with damaged output unit to Inovance for repair.
- The PLC is designed for indoor electric environment. A lightning protection device must be installed for the power supply system, so that lightning overvoltage is not applied on terminals of the PLC, avoiding damage to the equipment.

### During Installation

#### **WARNING**

- Install the PLC in places free from dust, oil smoke, conducting dust, corrosive gas, combustible gas, high temperature, condensation, wind & rain, vibration and shock. In addition, electric shock, fire, malfunction may also cause damage and deterioration to the equipment.
- During screw hole processing and wiring, ensure that no metal filing and cable end falls into the ventilation hole of the controller, because such stuff may causes a fire, fault, or malfunction.
- After installation of the newly purchased PLC is complete, ensure that there is no foreign stuff on the surface of ventilation. Failure to comply may result in poor cooling effect during running, which may lead to a fire, fault or malfunction.
- The installation and wiring must be secure and reliable. Poor contact may cause malfunction.

### At Wiring

#### **DANGER**

- Ensure that all power supplies are cut off before installation or wiring.
- During screw hole processing and wiring, ensure that no metal filings or cable end drops into ventilation holes of the controller. Failure to comply may result in a fire, fault or malfunction.
- Perform wiring or plug/remove the cable connector only after power-off. Failure to comply may result in electric shock or damage to the circuit.

#### **WARNING**

- Don't provide external power supply to terminal 24+ of the main unit or expansion unit.
- Use shielded cables for high-frequency signal input/output in applications with severe interference to enhance anti-interference capacity of the system.

### During Running and Maintenance

**⚠ DANGER**

- Connection or removal of the communication cable, cables of the extension card and cables of the control unit can be performed only after power-off. Failure to comply may result in damage to the equipment or malfunction.
- The operations such as online modification, forcible output, RUN and STOP can be performed only after you read the manual and guarantee safety.

**⚠ WARNING**

- Treat scrapped PLC as ordinary industrial waste.

**Product Information**

**Designation Rules**

H0U-0808 MRT -XP-6AT  
 ① ② ③ ④ ⑤ ⑥ ⑦ ⑧ ⑨ ⑩

- ① Product information                      H: Inovance controller
- ② Series No.                                    0U: TOD+PLC integrated controller
- ③ Input points                                08: 8 inputs
- ④ Output points                                08: 8outputs
- ⑤ Module classification                    M: Main module of general-purpose controller
- ⑥ Output type                                 R: Relay, T: Transistor
- ⑦ Output type                                 Mixed output
- ⑧ Reserved for future expansion
- ⑨ CPU type                                    XP: NXP-type CPU
- ⑩ Special function                          6AT (standard): built-in analog extension card; 6ATC (customized): built-in analog extension card and CAN card; CAN (customized): built-in CAN card

**Basic Parameters**

The following table describes the basic parameters of the H0U series PLC.

Table 1 Basic parameters of the H0U series PLC

PLC Model	Total I/Os	I/O Features					Communi- cation interface	Built-in Analog Card
		Total Inputs	High-Spee- d Inputs	Total Outputs	High-Sp- eed Outputs	Output Type		
H0U-0808M R-XP	16	8	2 x 60 kHz 4 x 10 kHz	8	-	Relay	2 x RS485 1 x USB	-
H0U-0808M RT-XP					2 x 100 kHz	Transistor		
H0U-1616M R-XP	32	16	2 x 60 kHz 4 x 10 kHz	16	-	Relay		
H0U-1616M RT-XP					2 x 100 kHz	Transistor		
H0U-0808M R-XP-6AT	16	8	2 x 60 kHz 4 x 10 kHz	8	-	Relay	2 x RS485 1 x USB	6AT
H0U-0808M					2 x 100	Transistor		

PLC Model	Total I/Os	I/O Features					Communication interface	Built-in Analog Card
		Total Inputs	High-Speed Inputs	Total Outputs	High-Speed Outputs	Output Type		
RT-XP-6AT					kHz			
H0U-1616M R-XP-6AT	32	16	2 x 60 kHz 4 x 10 kHz	16	-	Relay		
H0U-1616M RT-XP-6AT					2 x 100 kHz	Transistor		

**Note**

Total frequencies of high-speed inputs do not exceed 70 kHz.

The following table describes the functions of the built-in extension cards.

Table 2 Functions of the built-in extension cards

Extension Card Model	Analog Input	Analog Output	Temperature Detection	CAN Communication
6AT	Voltage: -10 to +10 V Current: 4–20 mA Current: -20 to +20 mA They are switched over via soft component.	Voltage: -10 to +10 V Current: 4–20 mA Current: 0–20 mA They are switched over via soft component.	A total of three terminals are available, supporting 2-channel temperature detection and also PT100 and TC detection, which are switched over via software.	-
6ATC	Voltage: -10 to +10 V Current: 4–20 mA Current: -20 to +20 mA They are switched over via soft component.	Voltage: -10 to +10 V Current: 4–20 mA Current: 0–20 mA They are switched over via soft component.	A total of three terminals are available, supporting 2-channel temperature detection and also PT100 and TC detection, which are switched over via software.	One CAN communication port supporting CANlink protocol
CAN	-	-	-	One CAN communication port supporting CANlink protocol

## General Specifications

Table 3 General specifications of the H0U series PLC

Environment Parameters				Use Condition	Transportation Condition	Storage Condition
Type	Parameter	Unit				
Climate condition	Ambient temperature	Low temperature	°C	-5	-40	-40
		High temperature	°C	55	70	70
	Humidity	Relative humidity	%	95 (30°C ± 2°C)	95 (40°C ± 2°C)	-
	Air pressure	Low pressure	kPa	70	70	70
High pressure		kPa	106	106	106	
Mechanical stress	Sine vibration	Shift	mm	3.5 (5–9 Hz)	-	-
		Acceleration	m/s <sup>2</sup>	10 (9–150 Hz)	-	-
	Random vibration	Acceleration spectral density	m <sup>2</sup> /s <sup>3</sup> (dB/Oct)	-	5–20 Hz: 1.92 dB 20–200 Hz: -3 dB	-
		Frequency range	Hz	-	5–200	-
		Vibration direction	-	-	X/Y/Z	-
	Shock	Type	-	-	Half-sine	-
		Acceleration	m/s <sup>2</sup>	-	180	-
Dip	Dip height	m	-	1	-	

## Mechanical Design

The following figure shows the installation dimensions of the H0U series PLC.

Figure 1 Installation dimensions of the H0U series PLC

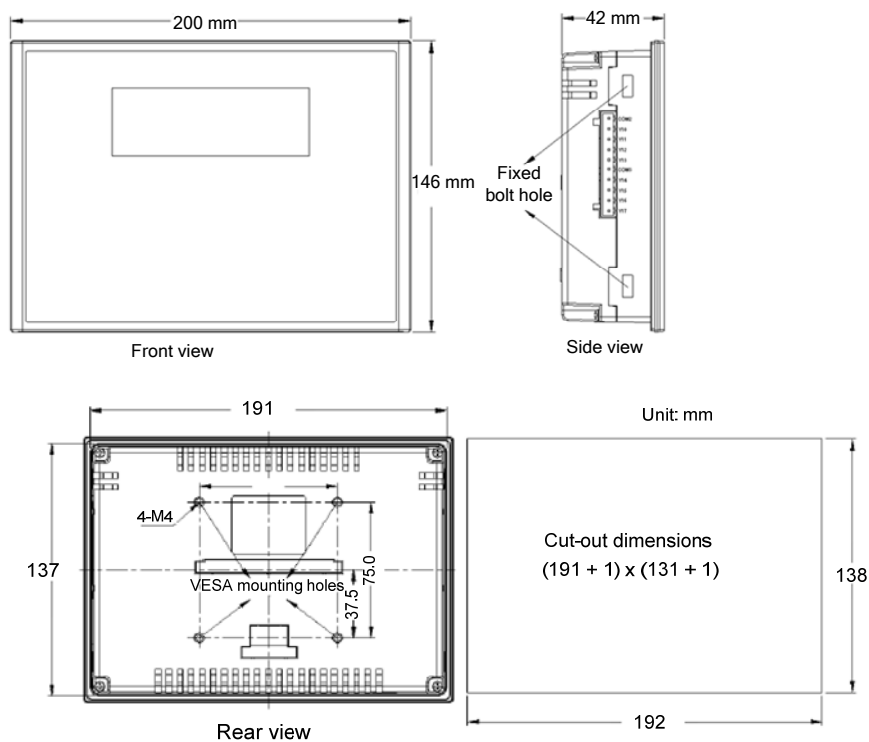

## Electrical Design

The following figure shows the structure of the H0U series PLC.

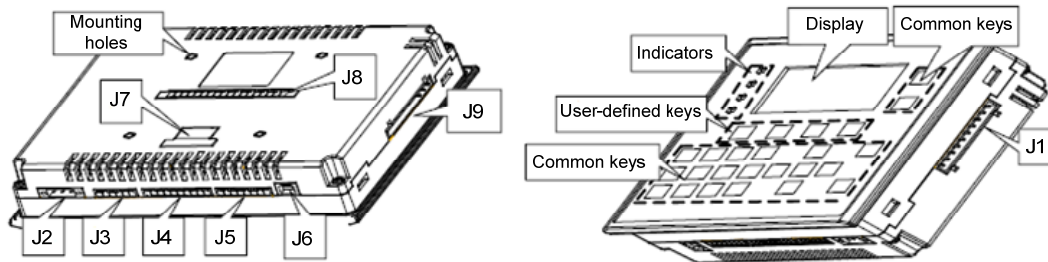

Table 3 Structure of the H0U series PLC

Terminal	Terminal Name	Terminal	Terminal Name
J1	Output terminals (Y0 to Y7)	J2	Power supply interface
J3	Serial communication port (RS485)	J4	Input terminals (X0 to X7)
J5	Input terminals (X10 to X17)	J6	USB client (Type B)
J7	Used for extended CAN function	J8	Interface for built-in analog extension card
J9	Output terminals (Y10 to Y17)		

## Wiring (Hardware)

The following figure shows the wiring of the H0U series PLC.

Figure 2 Wiring of the H0U series PLC

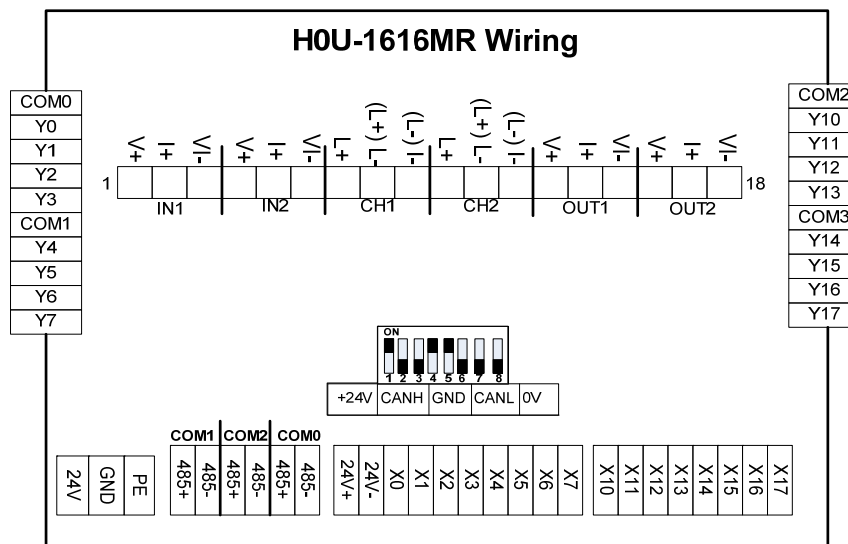

## Communication Ports

The H0U series PLC has four communication ports as standard configuration. COM0, COM1 and COM2 are standard RS485 communication interfaces. COM0 is used for user program downloading, commissioning and monitoring. COM1 and COM2 are free interfaces and support the Modbus protocol, N:N protocol, parallel protocol, HMI protocol,

PC link protocol, RS instruction and Modbus instruction. The other one is USB interface, which has the same function as COM0.

### Power Supply Specification

The H0U series PLC adopts the DC/DC power supply.

The input voltage of the DC/DC power supply is 24 V. The outputs are +5V/+24VDD/GND and +5V/COM respectively. +5V/+24VDD/GND provides power supply to the digital circuits and relays of the H0U, while +5V/COM provides power supply to transistor in the mixed output.

The DC/DC power supply adopts self-excitation to generate pulse width modulation (PWM) square wave and uses TL431 for feedback. The power supply voltage of the main circuit is +5V/GND.

The following table describes the power supply specification of the H0U series PLC

Table 4 Power supply specification of the H0U series PLC

Item	Voltage (V)	Current (mA)	Power (W)
Input	19.2–28.8		
Output	+5V	4.5–5.5	800
	+24VDD	18.5–26.5	150
	+5V	4.5–5.5	100
Total output power	8.1		

### Input Specification

For the X terminals, the rated input voltage is 24 VDC. Relative to COM (0V), the X terminals is OFF when the input voltage is below 4.0 V, is ON when the input voltage is above 15.0 V and is not fixed when the input voltage is 4.0–15.0 V. On the condition of rated input voltage of 24 VDC, the input current is 4–6 mA.

Item	High-speed Inputs X0–X5	General Inputs
Signal input mode	Sink input	
Electrical parameters	Input voltage	24 VDC
	Input impedance	3.3 kΩ
	Input ON	Input current > 4.5 mA
	Input OFF	Input current < 1.5 mA
Filter function	Hardware filter	
High-speed function	The other I/O terminals except X0 to X7 are hardware filter. The filter time is about 10 ms.	
	The maximum frequency counted at X0 and X1 reaches up to 60 kHz. The maximum frequency counted at X2 to X5 reaches up to 10 kHz. The total frequency is not higher than 60 kHz.	

### Output Specification

For the Y terminals, the output mode is dry-contact. The output is active (state "1") when

the terminal is ON and is inactive (state "0") when the terminal is OFF.

The 250 VAC reinforced insulation must be satisfied between the relay outputs and the logic circuit of the PLC. In addition, the 250 VAC reinforced insulation must be satisfied between the output terminals of different common terminals.

Item		Relay Output	Transistor Output
Circuit voltage		250 VAC, 30 VDC below	5–24 VDC
Circuit insulation		Relay mechanical insulation	Optically coupling insulation
Action indication		Output contact closing	Contact closing when optically coupling is driven
Leakage current at open circuit		-	< 0.1 mA/30 VDC
Minimum load		2 mA/5 VDC	5 mA (5–24 VDC)
Maximum output current	Resistive load	2 A for a point 8 A for 4 points in a group sharing a common terminal 8 A for 8 points in a group sharing a common terminal	0.5 A for a point 0.8 A for 4 points 1.6 A for 8 points
	Inductive load	220 VAC, 80 VA	High-speed outputs: 7.2 W/24 VDC Others: 12 W/24 VDC
ON response time		20 ms (max.)	High-speed outputs: 10 us Others: 0.5 ms
OFF response time		20 ms (max.)	
High-speed output frequency		-	100 kHz per channel (max.)
Output common terminal		Each group shares a common terminal COM. The groups are insulated.	
Fuse protection		-	

**Note**

When some or all transistors in each group are with load, the average current for each channel must not exceed 0.2 A. The maximum current for a single channel must not exceed 0.5 A.

**Internal Equivalent Circuit**

The following figure shows the internal equivalent circuit of relay output. Output terminals are divided into several groups, with each group electrically isolated. The output contacts of different groups are connected to different power circuits.

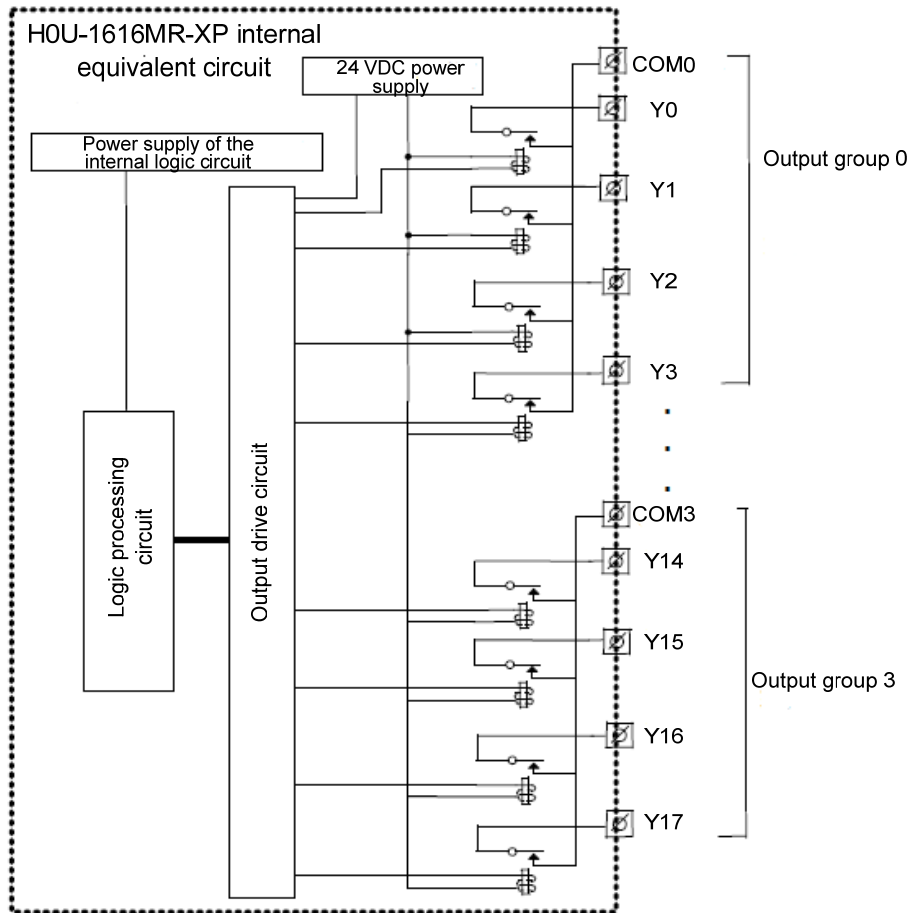

The following figure shows the internal equivalent circuit of mixed output of transistor and relay. Output terminals are divided into several groups, with each group electrically isolated. The output contacts of different groups are connected to different power circuits. Transistor output can be applied only to 24 VDC load circuit.

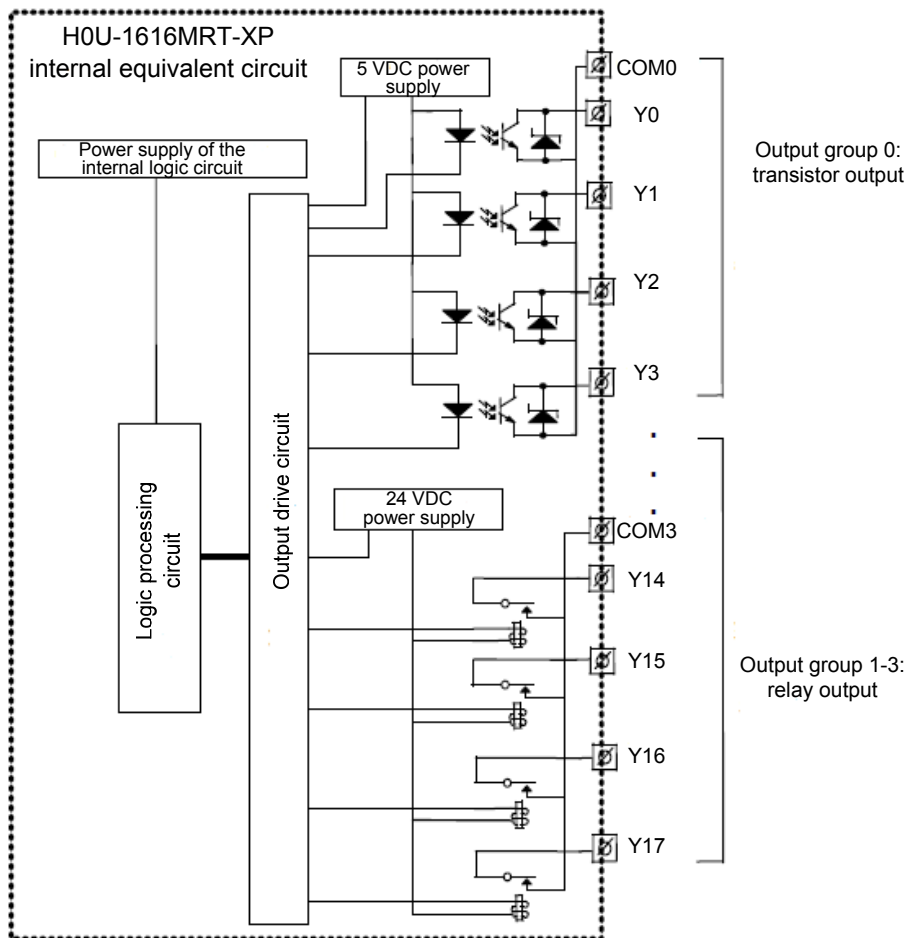

The following figure shows the internal equivalent circuit of PLC signal input. The user circuit is connected to the internal PLC circuit via wiring terminals. Sink input wiring is always used for H0U.

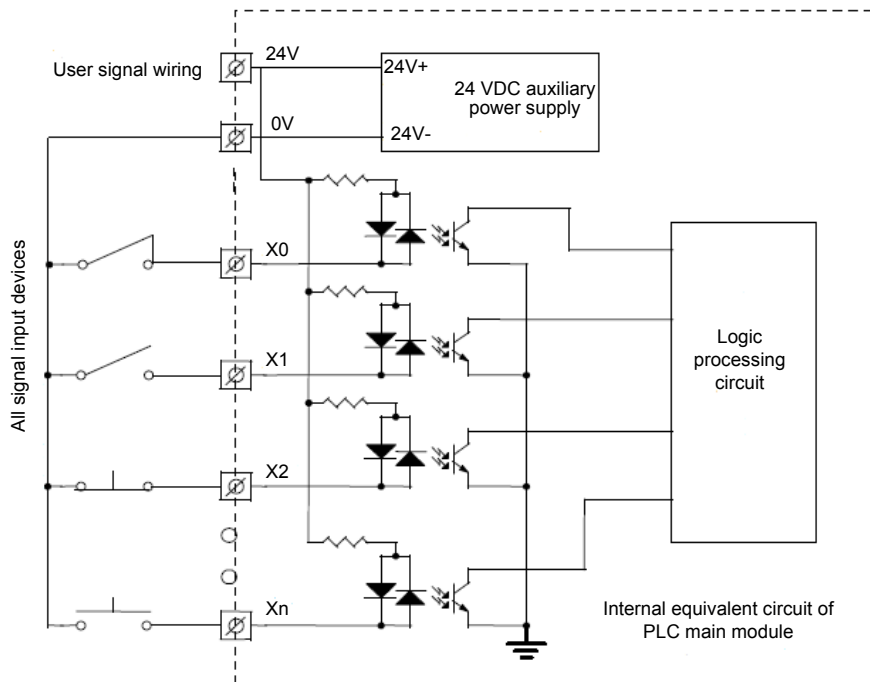

For the inductive load connected to the AC circuit, use the RC instantaneous voltage snubber circuit for the external circuit. For the inductive load connected to the DC circuit, add a flywheel diode, as shown in the following figure.

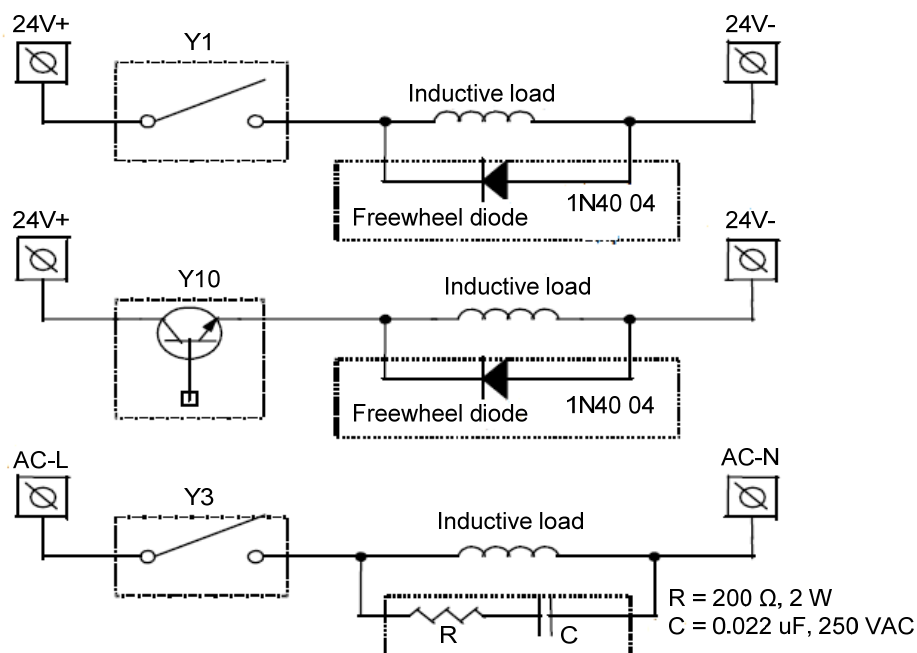

## Programming Reference

### Basic Specifications of the Integrated Equipment

#### 1. Text specifications

Item		Specifications
Display property	Display area	192 x 64
	LCD type	Yellow green background, dark blue character
	Background light	Yellow green LED background light
	Language	English/Chinese
	Physical dimensions	130 x 65 mm
	Display size	104 x 39 mm
	Weight	105 g
	Power supply	3.3 V
Storage	Flash	56 KB

#### 2. PLC specifications

Item	Specifications
Program execution mode	Cycling scanning





Programming mode	Ladder logic diagram, instruction list, SFC
Processing speed	0.26 ns (basic instruction)
Retentive at power failure	Flashrom retentive
User program capacity	8 k steps
I/O points	8 inputs 8 outputs, 16 inputs 16 outputs
High-speed processing capability	2-channel high-speed counting, 2 pulse output
Communication function	RS485/USB communication







## Description of Keys on the Operation Panel

### 1. Key setting

The operation panel consists of 25 keys. The functions of the keys are the same as those of the HMI.

### 2. Functions of the keys

Key	Name	Function Description
	ESC	<ol style="list-style-type: none"> <li>1) On the default interface, press this key to enter the main menu.</li> <li>2) When an alarm occurs, press this key to returns to the interface before occurrence of the alarm.</li> <li>3) In the menu mode or parameter edit mode, press this key to return to the previous operation or give up the current operation.</li> </ol>
	SET	<ol style="list-style-type: none"> <li>1) When an editable register parameter exists and allows edition, press this key to enter the editing mode.</li> <li>2) In the parameter editing mode, press this key to give up editing of this parameter and go to the next parameter. If there is no next parameter to be edited, the editing mode will be exited.</li> <li>3) If there is no editable parameter or the parameters do not allow edition, pressing this key is invalid.</li> </ol>
	Down	In the menu control, if there is a cursor line, press this key to move the cursor down to the next cursor line. If a parameter is being set, press this key to increase the value where the cursor is located by 1.
	Up	In the menu control, if there is a cursor line, press this key to move the cursor up to the previous cursor line. If a parameter is being set, press

		this key to decrease the value where the cursor is located by 1.
	Left	If there is a cursor during parameter or item setting, press this key to move the cursor left.
	Right	If there is a cursor during parameter or item setting, press this key to move the cursor right.
	Confirm	<p>1) In the menu mode with a cursor line, press this key to go to the next-level menu or view parameter information of the selected item.</p> <p>2) In the parameter editing state, press this key to confirm edition of the parameter and enter the editing state of the next parameter.</p>
	Numbers 0–9	Press these keys to enter the corresponding number when setting parameters.
	+/-	Press this key to set the positive or negative value of the data.
	CLR	Press this key to clear the setting.

**Note**

Besides the default functions, basic function keys can also be used as user-defined keys, and you can define their functions by using the background software.

### 3. User-defined keys

Another six user-defined keys are available, including F1 to F4, RUN, and STOP. You can define the functions of these keys by using the background software. The functions include coil setting, page skip, and register setting.

### 4. Indicators

The H0U has four indicators, as described in the following table.

Indicator	State	Description
POWER	OFF	There is no power supply.
	Steady	The system is powered on.

	ON	
RUN	OFF	The H0U is partially stopped.
	Steady ON	The H0U is partially running.
ALARM	OFF	The system is in normal state without fault, or the faults have been rectified.
	Steady ON	The system is faulty with alarm.
Standby indicator	N/A	N/A

### **H0U Soft Component**

The use of soft components of the H0U series PLC is the same as that of the H1U series PLC.

### **PLC Instruction List**

The basic PLC instructions of H0U are the same as those of H1U.