



AC SPEED CONTROL EQUIPMENT

VAT-3FD

3ph 380V-460V System 50 to 460KVA
Constant Torque Series UADX..
Variable Torque Series UADVX..

INSTRUCTION MANUAL

----- NOTICE -----

1. Read this manual thoroughly before using the VAT3FD, and store in a safe place for reference.
2. Make sure that this manual is delivered to the final user.
3. When using this inverter in the EU, compliance with the EMC Directive (89/336/EEC) is required. Thus, in this case, check carefully the section 7-3. For more information refer to the separate "EMC Application Manual" (PCST-3088E), and install and wire accordingly.
4. The contents of this manual can be changed without notice

GE POWER CONTROLS

Contents

Preface	iii
Precautions for Safety	iv
1- Precautions for Transportation and Installation	iv
2- Precautions for Wiring	v
3- Precautions for Operation	v
4- Precautions for Maintenance, Inspection and part replacement	vi
5- Others.....	vi
<Names of each part>	vii
Chapter 1 Delivery Inspection and Storage	1-1
1-1 Delivery Inspection and Storage	1-1
1-2 Details of Rating Nameplate and Model Display Method	1-1
Chapter 2 Installation and Wiring	2-1
2-1 Installation Environment	2-1
2-2 Installation	2-1
2-3 Precautions for Power Supply and Motor Wiring	2-2
2-4 Precautions for Wiring to the Control Signal	2-6
Chapter 3 Test Operation and Adjustment	3-1
3-1 Flow of Test Operation	3-1
3-2 Settings of Data Before Operation	3-2
3-3 Test Operation with Operation Panel	3-2
Chapter 4 Operation Panel	4-1
4-1 Details of Operation Panel	4-1
4-2 Modes and Parameters	4-3
4-3 Changing Modes	4-5
4-4 Reading Parameters in Monitor Mode	4-6
4-5 Reading and Adjusting Block-A & B Parameters	4-7
4-6 Reading the Parameters That Have Been Changed	4-9
4-7 Customizing Block-B Parameter	4-11
4-8 Reading Fault History	4-14
Chapter 5 Control Input/Output	5-1
5-1 Input/Output Terminal Function	5-1
5-2 Control Input/Output Circuit	5-3
5-3 Sequence Input Logic	5-4
5-4 Changing of Terminal Functions	5-5

Chapter 6 Control Functions and Parameter Settings	6-1
6-1 Monitor Parameters	6-1
6-2 Block A Parameters	6-3
6-3 Block B Parameters	6-8
6-4 Program Ramp Function	6-39
6-5 Pattern Run Function	6-40
6-6 PID Control	6-41
Chapter 7 Options	7-1
7-1 Outline of Options	7-1
7-2 Dynamic Braking (DBR) option	7-2
7-3 Electro Magnetic Compliance, EMC	7-3
7-4 The use of AC and DC Line Reactors	7-6
Chapter 8 Maintenance and Inspection	8-1
8-1 Inspection Items	8-1
8-2 Measuring Devices	8-2
8-3 Protective Functions	8-3
8-4 Troubleshooting with Fault Display	8-4
8-5 Troubleshooting with No Fault Display	8-7
Appendix 1 Type Description System	A-1
2 External Dimensions	A-3
3 Fault Codes & Display	A-4
4 7-Segment LED Display	A-6

Preface

Please read this manual thoroughly before use, and keep the manual at hand for later reference. Also make sure that this manual is delivered to the final users.

WARNING

ALWAYS READ THIS MANUAL THOROUGHLY BEFORE USING THE VAT 3FD.

THIS INVERTER CONTAINS HIGH VOLTAGE CIRCUITS THAT MAY BE FATAL TO HUMANS. USE EXTREME CAUTION DURING INSTALLATION. MAINTENANCE MUST BE PERFORMED BY QUALIFIED TECHNICIANS, AND ALL POWER SOURCES MUST BE DISCONNECTED BEFORE ANY MAINTENANCE. SUFFICIENT NOTICE MUST BE GIVEN TO THE GENERAL OPERATORS AND WORKERS BEFORE STARTING.

- **ELECTRIC SHOCK MAY OCCUR IF THE FOLLOWING POINTS ARE NOT OBSERVED.**
 - DO NOT OPEN THE OUTER-COVER (FRONT COVER) WHILE THE POWER IS ON.
 - A CHARGE STILL REMAINS IN THE INVERTER WHILE THE INDICATOR IS LIT EVEN IF THE POWER HAS BEEN TURNED OFF. DO NOT OPEN THE OUTER-COVER (FRONT COVER) IN THIS CASE. WAIT AT LEAST 10 MINUTES AFTER THE INDICATOR GOES OUT.
 - DO NOT CONTACT THE ELECTRICAL CIRCUIT WHILE THE CHARGE LAMP ON THE PCB IS LIT. PERFORM SERVICING, ETC., AFTER WAITING AT LEAST 10 MINUTES AFTER THE LAMP GOES OUT.
 - ALWAYS GROUND THE INVERTER CASE. THE GROUNDING METHOD MUST COMPLY WITH THE LAWS OF THE COUNTRY WHERE THE INVERTER IS BEING INSTALLED.

- **THE INVERTER MAY BE DESTROYED IF THE FOLLOWING POINTS ARE NOT OBSERVED.**
 - BE SURE THE UNIT VOLTAGE RATING IS ADEQUATE TO THE POWER SUPPLY
 - OBSERVE THE INVERTER SPECIFICATIONS.
 - CONNECT ADEQUATE CABLES TO THE INPUT/OUTPUT TERMINALS.
 - ALWAYS KEEP THE INVERTER INTAKE/OUTTAKE PORTS CLEAN, AND PROVIDE ENOUGH VENTILATION.
 - ALWAYS OBSERVE THE CAUTIONS LISTED IN THIS INSTRUCTION MANUAL.

- **THIS INVERTER MAY GENERATE ELECTRO MAGNETIC NOISE TO THE SURROUNDINGS. CONSIDER THE POWER SUPPLY SYSTEM, INSTALLATION PLACE AND WIRING METHOD BEFORE INSTALLATION.**

CAUTION

When using this inverter in the EU, compliance with the EMC Directive (89/336/EEC) is required. Thus, in this case, check carefully the section 7-3. For more information refer to the separate "EMC Application Manual" (PCST-3088E), and install and wire accordingly.

Precautions For Safety

Items to be observed to prevent physical damage and to ensure safe use of this product are noted on the product and in this instruction manual.

- Please read this instruction manual and enclosed documents before starting operation to ensure correct usage. Thoroughly understand the device, safety information and precautions before starting operation. After reading, always store this manual where it can be accessed easily.
- The safety precautions are ranked as “**DANGER**” and “**CAUTION**” In this instruction manual.

DANGER : When a dangerous situation may occur if handling is mistaken leading to fatal or major injuries.

CAUTION : When a dangerous situation may occur if handling is mistaken leading to medium or minor injuries, or physical damage.

Note that some items described as **CAUTION** may lead to major results depending on the situation. In any case, important information that must be observed is described.

- This instruction manual is written on the premise that the user has an understanding of the inverter. Installation, operation, maintenance and inspection of this product must be done by a qualified person. Even qualified persons must undergo periodic training.

Qualified refers to satisfying the following conditions.

- The person has thoroughly read and understood this instruction manual
- The person is well versed in the installation, operation maintenance and inspection of this product, and understands the possible dangers,
- The person is informed on matters related to starting, stopping, installation, locks and tag displays, and has been trained in the operation and remedies.
- The person has been trained on the maintenance, inspection and repairs of this product.
- The person has been trained on protective tools used to ensure safety.

1. Precautions for Transportation and installation

CAUTION
<ul style="list-style-type: none">• Always transport the product with an appropriate amount according to the products weight Failure to observe this could lead to injuries.• Install the inverter and brake resistor on non-combustible material such as metal. Failure to observe this could lead to fires.• Do not place the product near inflammable items. Failure to observe this could lead to fires.• Do not hold the from cover while transporting the product. Failure to observe this could lead to injuries from dropping.• Do not led conductive materials such as screws or metal pieces and inflammable material such as oil enter the product. Failure to observe this could lead to fires.• Install the product in a place that can withstand the weight of the product, and follow the instruction manual Failure to do so could lead to injuries from dropping.• Do not install and operate an inverter that is damaged or that is missing parts. Failure to observe this could lead to injuries.• Always observe the conditions described in the instruction manual for the installation environment. Failure observe this could lead to faults.

2. Precautions for Wiring

DANGER

- Always turn the device's input power OFF before starting wiring.
Failure to do so could lead to electric shocks or fires.
- Always perform class 3 or higher grounding work.
Failure to do so could lead to electric shocks or fires.
- Wiring must always be done by a qualified electrician.
Failure to observe this could lead to electric shocks or fires.
- Always install the device before starting wiring.
Failure to do so could lead to electric shocks or injuries.
- Prepare a breaker such as an MCCB that matches the capacity for the inverter's power supply side
Failure to do so could lead to fires.

CAUTION

- Do not connect an AC power supply to the output terminals (U, V, W).
Failure to observe this could lead to electric shocks or fires.
- Confirm that the product's rated voltage and frequency match the power supply voltage and frequency.
Failure to do so could lead to injuries or fires.
- Install an overheating protection device on the dynamic electrical-discharge braking resistor, and shut off the power with an error signal.
Failure to do so could lead to fires in the event of abnormal overheating.
- Do not directly connect a resistor to the DC terminals (P (L+),N (L-)).
Failure to observe this could lead to fires.
- Tighten the terminals screws with the designated tightening torque.
Failure to do so could lead to fires.
- Correct connect the output side (U, V, W).
Failure to do so could cause the motor to rotate in reverse and the machine to be damaged

3. Precautions for Operation

DANGER

- Always install the from cover before turning the input power ON. Never remove the cover while the power is ON. There are sections in the from PCB that are charged with high voltages.
Failure to observe this could lead to electric shocks.
- Never touch the switches with wet hands.
Failure to observe this could lead to electric shocks.
- Never touch the inverter's terminals while the inverter power is ON even if the operation is stopped
Failure to observe this could lead to electric shocks
- Selection of the retry function could lead to unexpected restarting when an alarm occurs. The machine may start suddenly if the power is turned ON when the automatic start function is selected Do not go near the machine.
Failure to do so could lead to injuries.
(Design the machine so that physical safety can be ensured even if the machine restarts.)
- The machine may not stop when a stop command is issued if the deceleration stop function is selected. Prepare a separate emergency stop switch.
Failure to do so could lead to injuries.
- Resetting of an alarm while the run signal is input could lead to unexpected restarting. Always confirm that the run signal is OFF before resetting the alarm.
Failure to do so could lead to injuries.

Continue from previous page

CAUTION

- The radiating fins and electrical discharge resistor are heated to high temperatures, so never touch them.
Failure to observe this could lead to burns.
- Do not block the inverter's ventilation holes.
Failure to observe this could lead to fires.
- The inverter operation can easily be set from low speeds to high speeds, so confirm that the operation is within the tolerable range for the motor or machine before making settings.
Failure to do so could lead to injuries.
- Prepare holding brakes when necessary. Holding is not possible with the inverter's brake functions.
Failure to do so could lead to injuries.
- Confirm the operation of the motor as a single unit before operating the machine.
Failure to do so could lead to injuries or machine damage due to unforeseen movements.
- Always prepare a safety backup device so that the machine is not placed in a hazardous situation when an error occurs in the inverter.
Failure to do so could lead to injuries or machine damage.

4. Precautions for Maintenance, Inspection and Part Replacement

DANGER

- Always wait at least ten minutes after turning the input power OFF before starting inspections.
(Check the DC voltage between the terminals P (L+) and N (L-), and confirm that it is 15V or less)
Failure to observe this could lead to electric shocks.
- Maintenance, inspections and part replacement must be done by a designated person.
(Remove all metal accessories such as watches, bracelets, etc., before starting the work.)
(Always use an insulation measure tool.)
Failure to observe this could lead to electric shocks and injuries.
- Always turn the power OFF before inspecting the motor or machine . A potential is applied on the motor terminal even when the motor is stopped.
Failure to do so could lead to electric shocks and injuries.
- Do not use parts other than those designated for the replacement parts.
Failure to observe this could lead to fires.

CAUTION

- Vacuum the inverter with a vacuum cleaner to clean it. Do not use organic solvents.
Failure to observe this could lead to fires or damage.

5. Others

DANGER

- Never modify product.
Failure to observe this could lead to electric shocks or injuries.

CAUTION

- Dispose of this product as industrial waste.

<Names of each part>

For UADX600GS, UADVX750GS and smaller

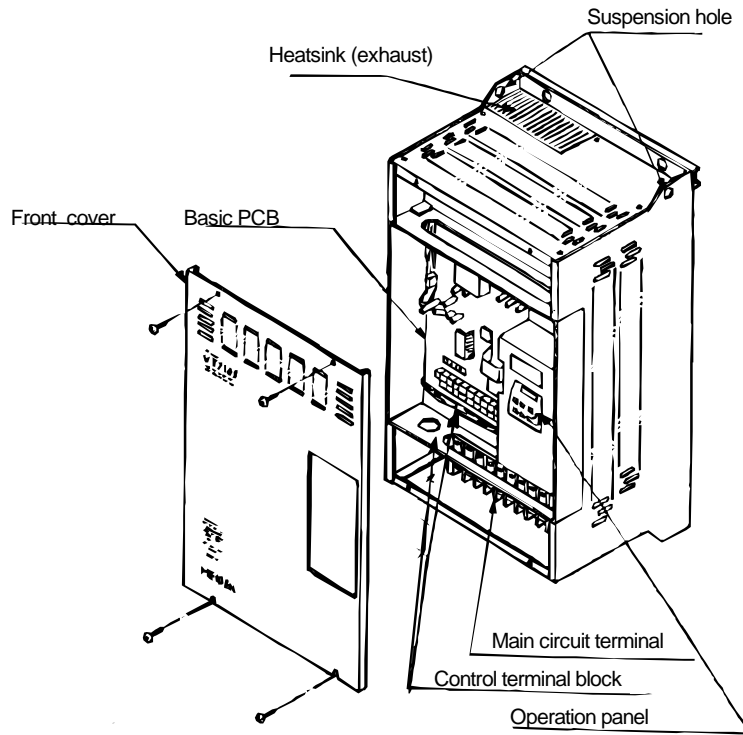

For UADX750GS, UADVX1000GS and larger

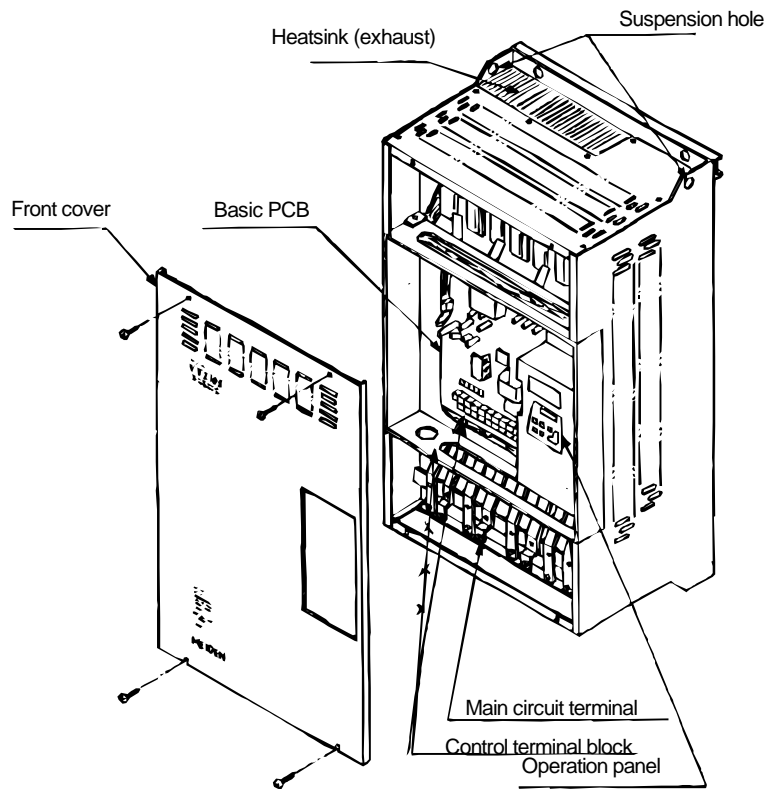

1. Delivery Inspection and storage

Chapter 1 Delivery Inspection and Storage

1-1 Delivery Inspection and Storage

- 1) Remove the inverter from the packaging, and check the details on the rating nameplate to confirm that the inverter is as ordered. The rating name plate is on top of the inner-cover.
- 2) Confirm that the product has not been damaged.
- 3) If the inverter is not to be used for a while after purchasing, store it in a place with no humidity or vibration in the packaged state.
- 4) Always inspect the inverter before using after storing for a long period. (Refer to 8-1.)

1-2 Details of Rating Nameplate and Type Display Method

- 1) The following details are listed on the rating nameplate.

VAT 3FD	UADX500GS
SOURCE	380-460V 50/60Hz
OUTPUT	72A
SERIAL NO.	

CAUTION

- UADX... are general purpose type units
UADVX.. are Variable Torque type units (only for load as Pump / Fans)

- 2) Using the above type as an example, the type is displayed as follows:

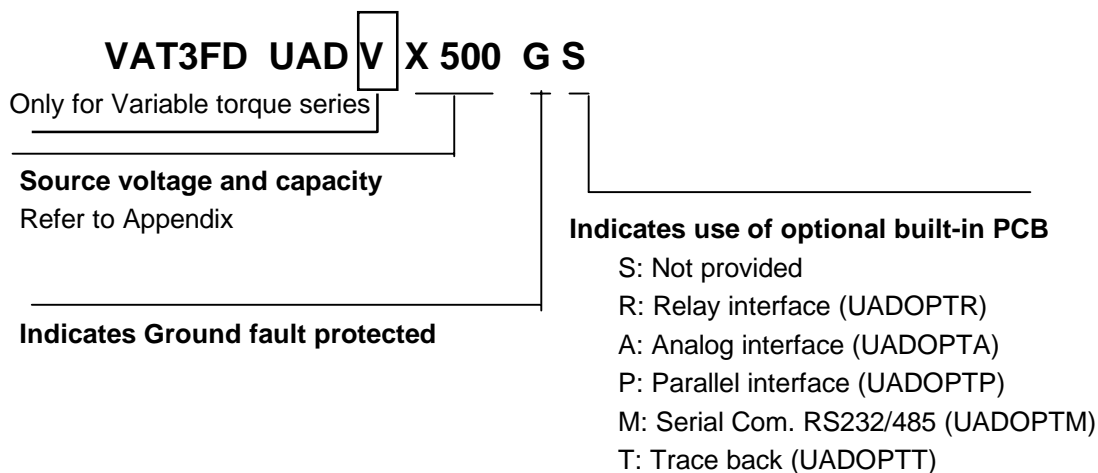

2. Installation and Wiring

Chapter 2 Installation and Wiring

2-1 Installation Environment

Observe the following points when installing the inverter.

- 1) Install the inverter vertically so that the wire lead-in holes face downward.
- 2) Make sure that the ambient temperature is -10°C to 50°C .
- 3) Avoid installation in the following environment.
 - Places subject to direct sunlight
 - Places with oil mist, dust or cotton lint, or subject to salty winds
 - Places with corrosive gas, explosive gas or high humidity levels
 - Places near vibration sources
 - Places made of flammable materials such as wood, or places that are not heat resistant
- 4) Ensure ventilation space around the inverter. (Refer to Fig.)

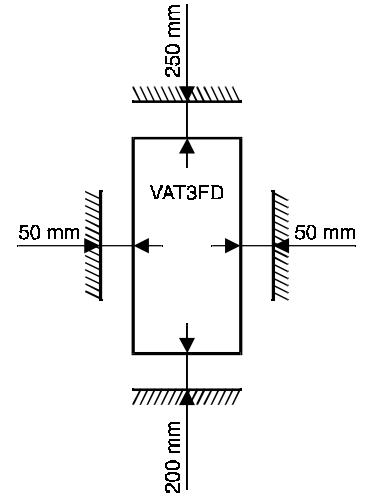

2-2 Installation

The upper installation holes are for hooks, and those on the lower side are notched. The VAT3FD mass is approx. from 30 to 300kg, so installation by two workers with appropriate tools is recommended.

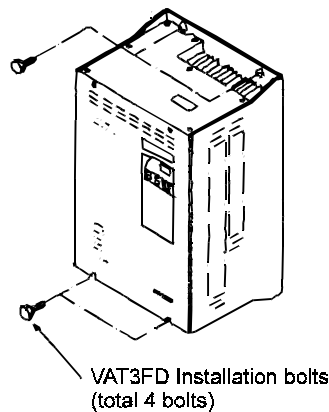

Fig 2.2

2. Installation and Wiring

2-3 Precautions for Power Supply and Motor Wiring

DANGER

- Always turn the device's input power OFF before starting wiring
Failure to do so could lead to electric shocks or fires
- Always perform class 3 or higher grounding work.
Failure to do so could lead to electric shocks or fires
- Wiring must always be done by a qualified electrician.
Failure to observe this could lead to electric shocks or fires
- Always install the device before starting wiring.
Failure to do so could lead to electric shocks or injuries.
- Prepare a breaker such as a MCCB that matches the capacity for the inverter's power supply side
Failure to do so could lead to fires.

CAUTION

- Do not connect AC power supply to the output terminals (U,V,W)
Failure to do so could lead to electric shocks or fires, and damage the drive
- Confirm that the product's rated voltage and frequency match the power supply voltage and frequency
Failure to do so could lead to injuries or fires
- Do not directly connect a resistor to the DC terminals P (L+), N (L-)
Failure to do so could lead to fires
- Tighten the terminal screws with the designated tightening torque.
Failure to do so could lead to fires
- Connect accordingly the output side (U,V,W).
Failure to do so could cause the motor to rotate in reverse and the machine to be damaged

CAUTION

Risk of electric shocks

An electrolytic capacitor is built into the VAT3FD, so there will be a charge even when the inverter power is turned OFF. Observe the following items when wiring.

- Wait 20 minutes or more before starting work after turning the power OFF. Confirm that all indicators on the operation are out before opening the cover.
- After opening the cover, confirm that the CHARGE lamp at the positions shown below is out. Check the DC voltage between (P2) and (L-) and start the wiring only if the voltage measured is 15V or less.

< CHARGE lamp positions >

VAT3FD X500-X1200
VX550-VX1400

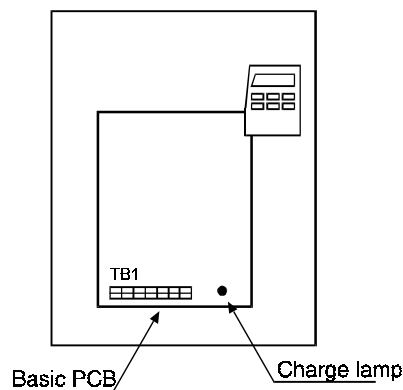

VAT3FD X1500 and larger
VX1700 and larger

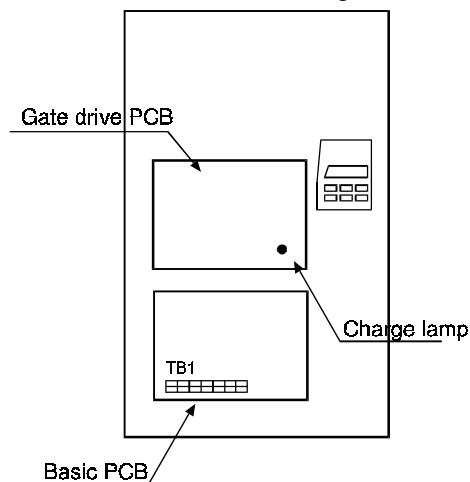

2. Installation and Wiring

Main circuit wiring

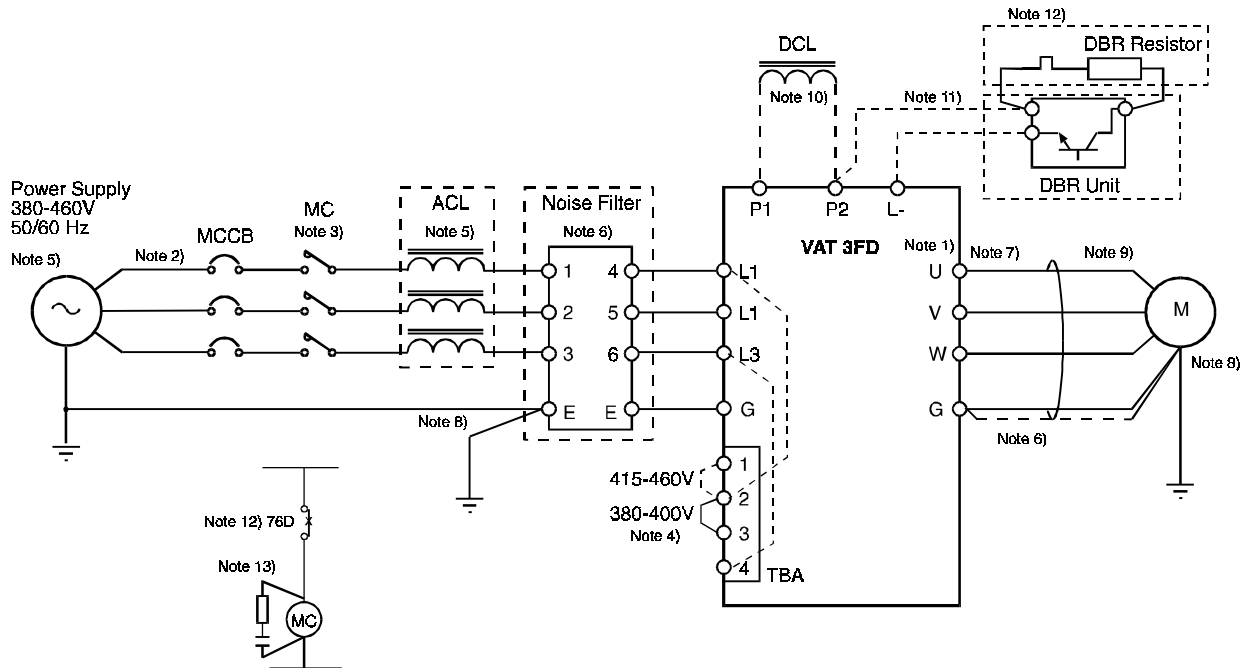

Fig. 2.3 Main circuit wiring

Note 1) Inverter Input/Output terminals

The inverter input terminals are L1, L2 and L3. The output terminals to the motor are U, V and W. Do not connect the power supply to the U, V, W terminals. incorrect wiring will lead to inverter damage.

Note 2) Wire size

Use wires having the wire size or larger shown in Table 2.1 for the main circuit wiring shown in Fig. 2.3. The applicable wire size range, applicable crimp terminal and tightening torque for the main circuit terminal block are shown in Table 2.1.

Note 3) Breaker for wiring

Install an MCCB on the power supply side of the inverter. Refer to Table 7.2 and select the MCCB

Note 4) Rated voltage for auxiliary equipment supply

For the 400 Series, replace the short bar for the auxiliary equipment power supply terminal (TBA) according to the rated voltage of the power supply being used.

For 380 to 400V, short circuit across 2-3 (factory setting state)

For 415 to 460V, short circuit across 1-2

Note 5) Power supply capacity

The capacity of the transformer used as the inverter power supply must be between 1.3 and 10 times the inverter capacity. (When using 4% impedance transformer.)

If the power supply transformer has a capacity that exceeds 10 times that of the inverter, insert an ACL on the input side of the inverter. Refer to Table 7.2 and select the ACL. The ACL is also effective for suppressing the high harmonic current and improving the power factor.

Note 6) Noise measures

The inverter will generate high harmonic electromagnetic noise, so using the following noise measures is recommended.

When using the unit in the EU regions, the EMC Directives (89/336/EEC) must be followed. Refer to this manual (section 7-3), and the separate "EMC Manual" when wiring.

2. Installation and Wiring

- a) Insert a noise filter on the input side of the inverter. Refer to section 7.3 and select the noise filter.
- b) Keep the wiring length between the noise filter and inverter to 50cm or less.
- c) Use a screen cable for the inverter and motor wiring, and connect the screen to the inverter's G terminal and motor grounding terminal.
- d) When using the circuit control wiring explained in section 2-4 and the main circuit wiring in this section in parallel, separate the wiring by 30cm or more, or pass each of the wiring through metal conduits. If the control circuit wiring intersect, make sure that they intersect at a right angle.

Note 7) Inverter output

- a) Do not insert a power factor improvement capacitor on the output side of the inverter.
- b) When inserting a magnetic contactor on the output side of the inverter, prepare a sequence control circuit so that the magnetic contactor will open and close when the inverter stops.

Note 8) Grounding

Always ground the inverter unit grounding terminal (G) and the ground according to the regulations of the Country where the inverter is being used . Ground the motor grounding at the motor installation position.

Note 9) Inverter output surge voltage (For 400V Series)

As the inverter output cable is lengthened, the surge voltage applied on the motor also increases. If the wiring between the inverter and motor exceeds 20m, connect a surge absorber exclusive for the inverter output.

Note 10) DCL

Always short circuit across P1 and P2 when not using DCL. (Factory setting state)
When connecting the optional DCL, connect it to P1 and P2.
Twist the wiring to the DCL, and keep the wiring length to 5m or less.

Note 11) DBR unit

When connecting the optional DBR unit, follow Fig. 2.3 and connect the P2 and L-. The DBR unit and inverter unit will both be damaged if the connection is mistaken.
Twist the wiring to the DBR unit, and keep the wiring length to 3m or less.
Refer to section 7-2 for details.

Note 12) DRB protection

When using the optional DBR unit, insert a thermal relay (76D) to protect the DBR resistor and inverter. Prepare a sequence control circuit to turn OFF the magnetic contactor (MC) on the input side of the inverter or trip the wiring breaker (MCCB) with trip coil using this relay contact.

Note 13) Installation of surge absorber

Install a surge absorber on the magnetic contactor and relay coils installed near the inverter.

Table 2.1 Applicable wire sizes and terminals

Inverter type VAT3FD (400V series)	X500	X750	X1000	X1500	X1700	X2200	X3000,	X4000
	X600 VX550	VX750	X1200 VX1000 VX1200	VX1400 VX1700		VX2200 VX2500	X3600 VX3300	VX4000 VX4600
Applicable wire (mm ²)	38	60	100	150		100x2p	150x2p	250x2p
Max. crimp Terminal (mm)	d1	22,5	22,5	28,7	36	36	36	44
	d2	8,4	10,5	10,5	10,5	13	17	17
								
Terminal screw	M8	M10			M12		M16	
Tightening torque (N.m)	8-10	15-20			25-35		70-90	

Note)2p refers to two parallel connections.

2. Installation and Wiring

Terminal layout. (Fig 2.4)

a) Connections for UADX500, UADX600, UADVX550, UADVX750

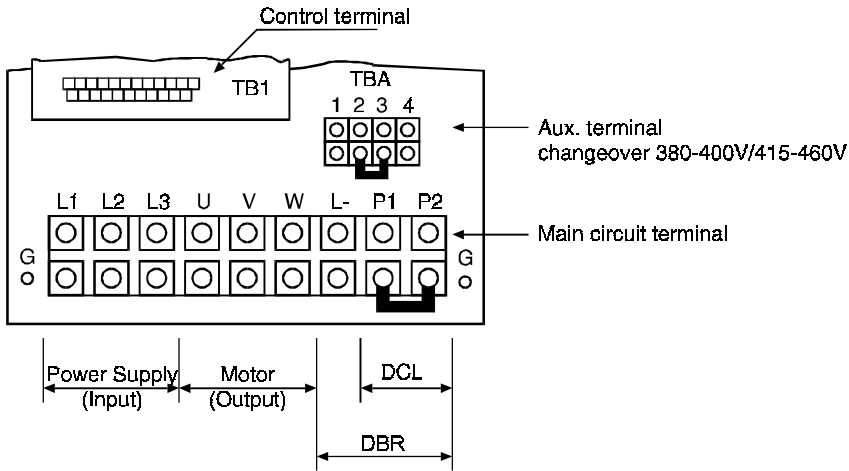

b) Connections for UADX750, UADX1000, UADX1200, UADX1500, UADX3000, UADX3600, UADX4000, UADVX1000, UADVX1200, UADVX1400, UADVX1700, UADVX3300, UADVX4000, UADVX4600

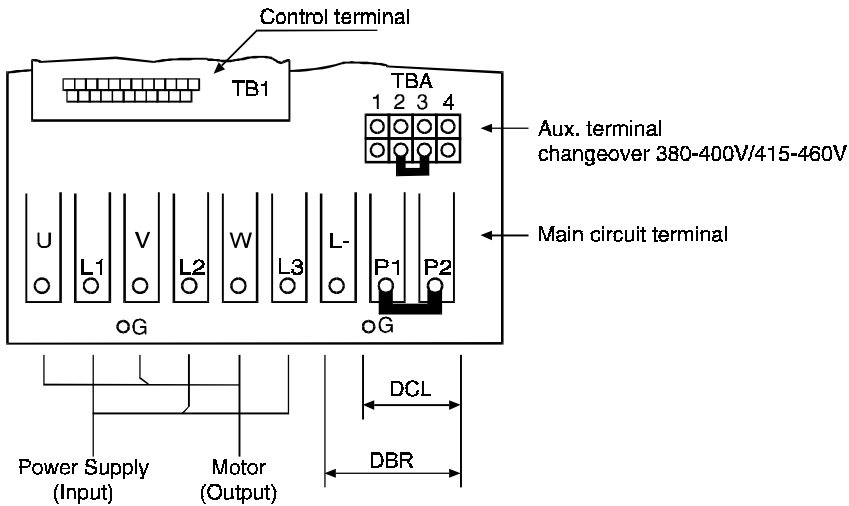

c) Connections for UADX1700, UADX2200, UADVX2000, UADVX2500

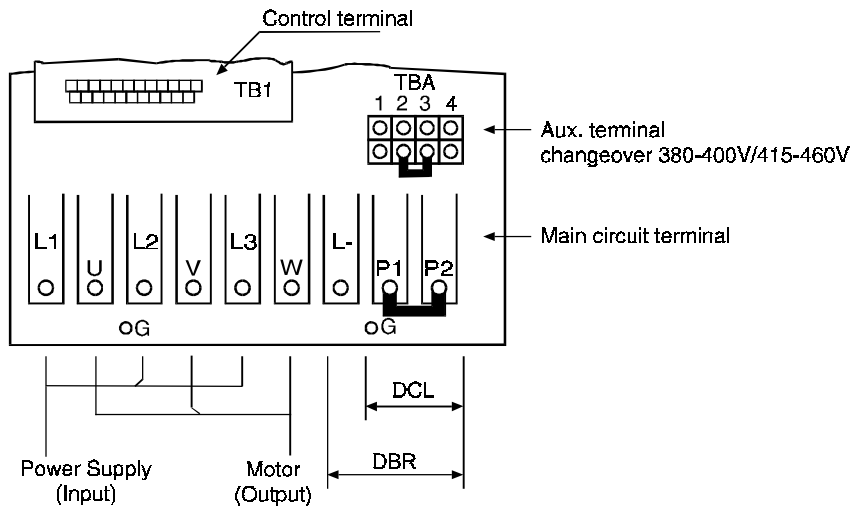

2. Installation and Wiring

2-4 Precautions for Wiring to the Control Signal

- 1) Use a 0.13 to 0.8mm² wire for connection to the control terminal block. The tightening torque must be 4,9N.m.
- 2) Use shielded wires for wiring to the setter and meters, etc. (analog signal circuit).
Connect the shielded wires to the VAT3FD COM terminal. The wire length must be 30m or less.
- 3) The length of the contact input/output wire must be 50m or less.
- 4) Follow the precautions listed in "Table 5.4 Control input/output circuit".

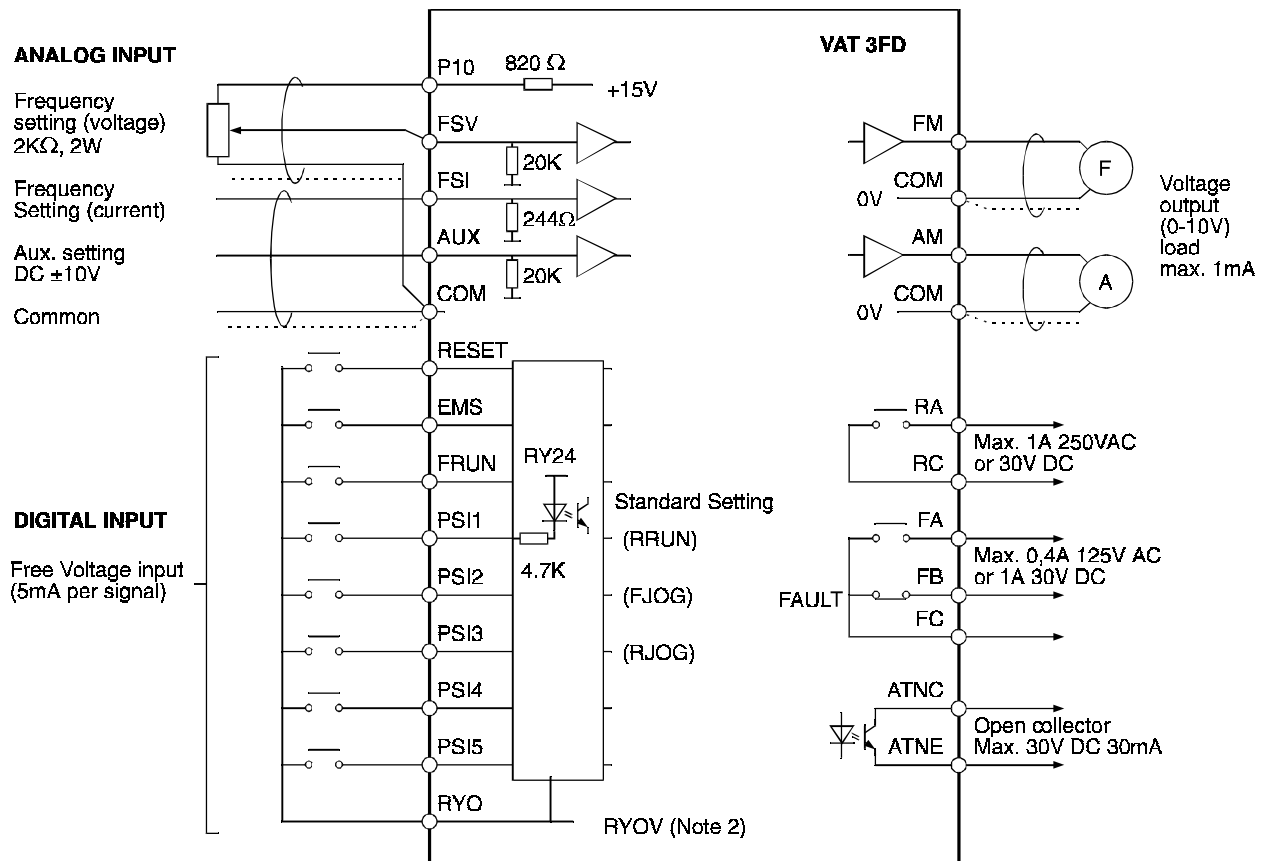

(Notes)

1. Three COM terminals are internally connected
2. No connection shall be made between RY0 and COM since this section is insulated.

• **Control Terminal** (The terminal block is laid out in two rows.)

RY0	PSI2	PSI4	FRUN	EMS	FSV	FSI	RA	RC	FC	FB	FA	ATNC
PSI1	PSI3	PSI5	RESET	P10	COM	AM	COM	FM	COM	AUX	ATNE	

Fig. 2.5

Chapter 3 Test Operation and Adjustment

All parameter of VAT3FD have been presetted for standard values in factory. Some of them should be changed before run.

3-1 Flow of Test Operation

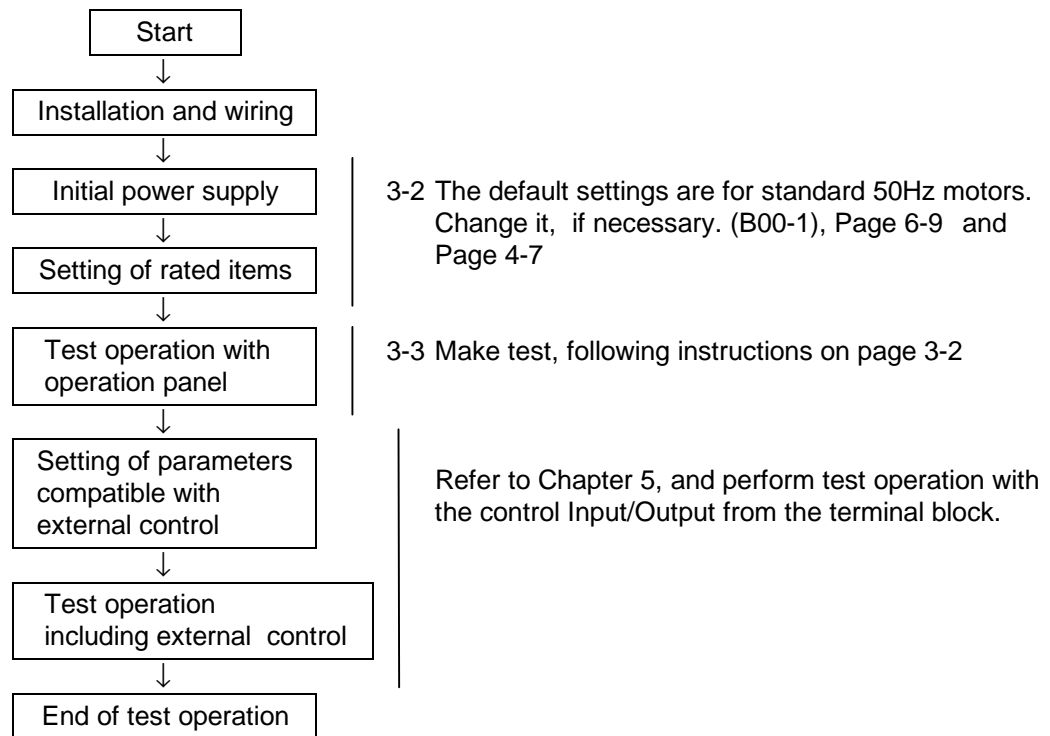

Fig. 3.1 Test operation procedure

<Caution>

1. Check that the wiring is correct.
2. The power supply must always be kept in the tolerable range.
3. Always check that the inverter rating and motor rating match.
4. Always correctly install the front cover and outer cover before turning the power on.
5. Be sure that the unit can be quickly disconnected if any problem happen.
6. Refer to the Chapter 6 and observe the precautions when changing the set values such as torque boost A02-0.

3. Test Operation and Adjustment

3-2 Settings of Data Before Operation

- (1) Turn ON the MCCB, and then turn ON the inverter power.

"**2 104**" ROM version" and "**d00-0**" will display momentarily on the indicator, and then "**OFF**" will display.



- The "LCL" and "Hz" lamps will also light. If not, please press **STOP** + **LCL SET** to select local control
- (2) Refer to section 4-5, and change.

3-3 Test Operation with Operation Panel

The test operation with the operation panel is performed with the following procedure.

<Caution>

Make sure that signals are not input into the F RUN, EMS, PSI1, PSI2 and PSI3 terminals on the sequence input terminals at this time.

- (1) Turn ON the power supply.

"**2 104**". "ROM version" and "**d00-0**" will display momentarily on the indicator, and then "**OFF**" will display.

The "LCL" and "Hz" lamps will also light. If not, please press **STOP** + **LCL SET** to select local control

<Caution>

The motor will run. Confirm the safety around the motor before starting the next step.

- (2) Press the **FWD** key.

The "FWD" lamp will light and the display will change from "**OFF**" to "**10.00**". This is because the local setting frequency (A00-0) is set to 10Hz as the default setting.

<Check>

1. Did the motor run?
2. Is the run direction correct? Check the wiring and operation if abnormal.
3. Is the rotation smooth?

- (3) Press the **REV** key and confirm that the motor runs in reverse.

- (4) Press the **STOP** key and stop the motor.

- (5) Press the **FWD** key. The motor will forward run at 10Hz.

- (6) Press the **RST MOD** key once. The display will alternate between "**A00-0**" and "**10.00**".

- (7) Press the **LCL SET** key once.



The display will stop at "**10.00**", and the decimal position will flicker. This completes the preparation for changing the output frequency.



The output frequency can be incremented/decremented with the **▲** and **▼** keys.

- (8) Press the **▲** key, and increment the frequency to 50Hz.

3. Test Operation and Adjustment

<Caution>

A 10-second acceleration and 20-second deceleration ramp time are set as defaults. The motor will slowly increase its speed to the set value. Increase the speed by approx. 10Hz at a time with the  and  keys.

- (9) Press the  key when the motor speed reaches 50Hz. The display will decrease to 0.00 in 20 seconds. The "FWD" or "REV" lamp will flicker for two seconds while the DC-brake is applied and the motor will stop.
- (10) Press the  key to test the reverse run.

This completes the test operation with the operation panel.

Refer to Chapter 4 and make the adjustments according to the user application.

4. Operation Panel

Chapter 4 Operation Panel

4-1 Details of Operation Panel

The configuration of the operation panel is shown in Fig. 4.1.

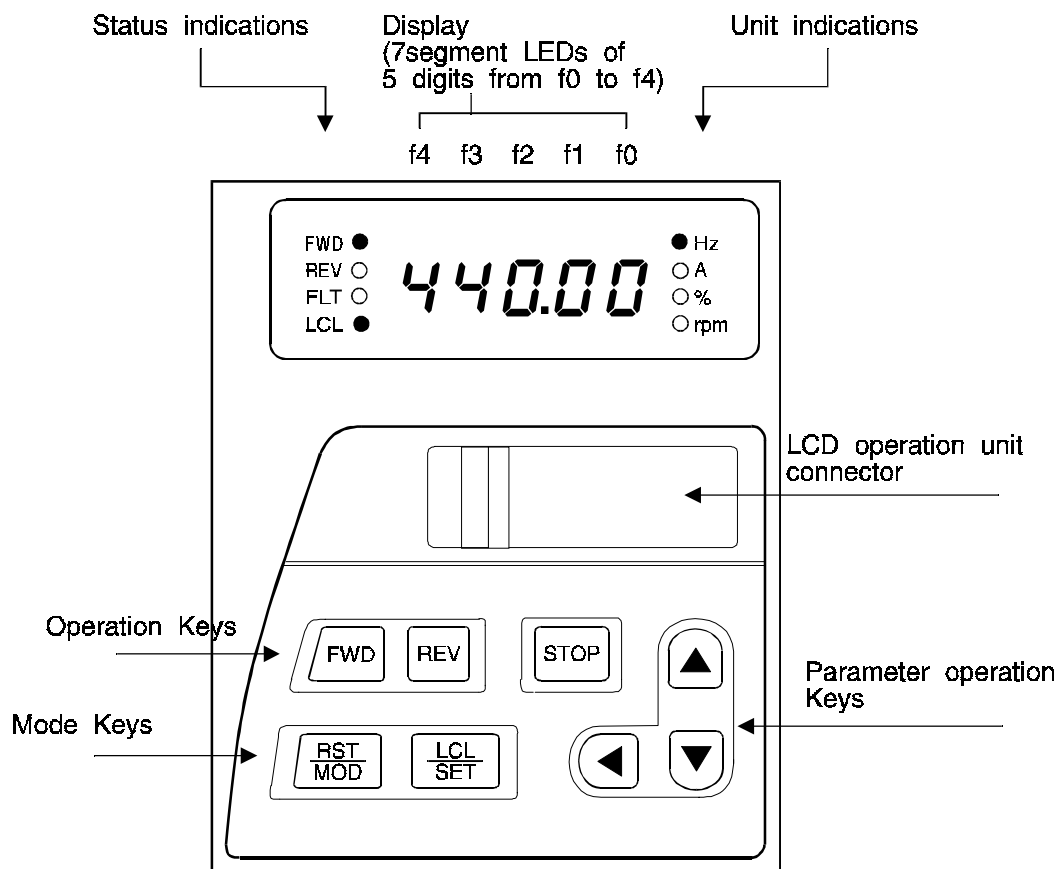



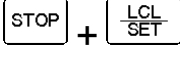
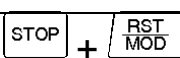









Fig. 4.1

4. Operation Panel

Table 4.1 Functions of operation panel

Status Indications LEDs		
FWD (Forward)	The drive is running in the forward direction.	When both lamps flicker simultaneously, it indicates that DC Brake is in action. When either of the lamps flickers, it
REV (Reverse)	The drive is running in the reverse direction.	indicates that the drive is ramping down against a command to change directions.
FLT (Fault)	The drive has detected a fault and has stalled. The drive can be reset from the Operation Panel (STOP + RST/MOD) or from the terminal block (external RESET)	
LCL (Local)	The drive is in the Local Mode and can be operated from the Operation Panel (FWD, REV and STOP only). When lamp is off, the drive is in the Remote Mode and can be controlled from the terminal block (external sequence commands). To change Modes, press STOP + LCL/SET.	
Unit Indication LEDs		
Hz-A-%	Indicate the unit of the value shown on the display.	
rpm	Indicate that the value shown on the display is the multiple of a parameter set on either <i>d00-2</i> or <i>d01-2</i> . Since the parameter <i>b05-2</i> is factory-set at 30.0, the value on the display is the speed in rpm of a 4-pole motor.	
Operation Keys		
	Start the drive in the forward direction. (in Local Mode only)	
	Start the drive in the reverse direction. (in Local Mode only)	
	Stop the drive. The motor will stop in mode selected on <i>b01-0</i>	
	Change control Modes from Local to Remote, or vice-versa. When the drive is in Local Mode, LCL lamp is on. (Note)	
	Reset a fault, putting out FLT LED.	
Parameter Operation Keys		
	(Mode)	Change display Modes in the following order. Monitor → Parameter-A → Parameter-B
	(SET)	Fix Parameter number or set its values.
	Increase Parameter Number or its values.	
	Decrease Parameter Number or its values.	
	Param. select	Change Parameter Block for the desired Parameter. To change to the next Block up, press  first. For the next block down, press  first.
	Value change	Move the cursor to the desired digit to adjust. The cursor is on the flickering digit.

Note) The drive is default set so that a Local/Remote selection is disabled while the drive is running. Even while the drive is at a stop, this selection cannot be made if operating commands such as F.RUN, JOG, etc., are being received at the terminal. This lock can be released with Parameter B06-0.

4. Operation Panel

4-2 Modes and Parameters

The VAT 3FD Parameters are classified as shown in Fig. 4.2. These parameters are grouped into Modes and Blocks according to their functions and frequency of usage.

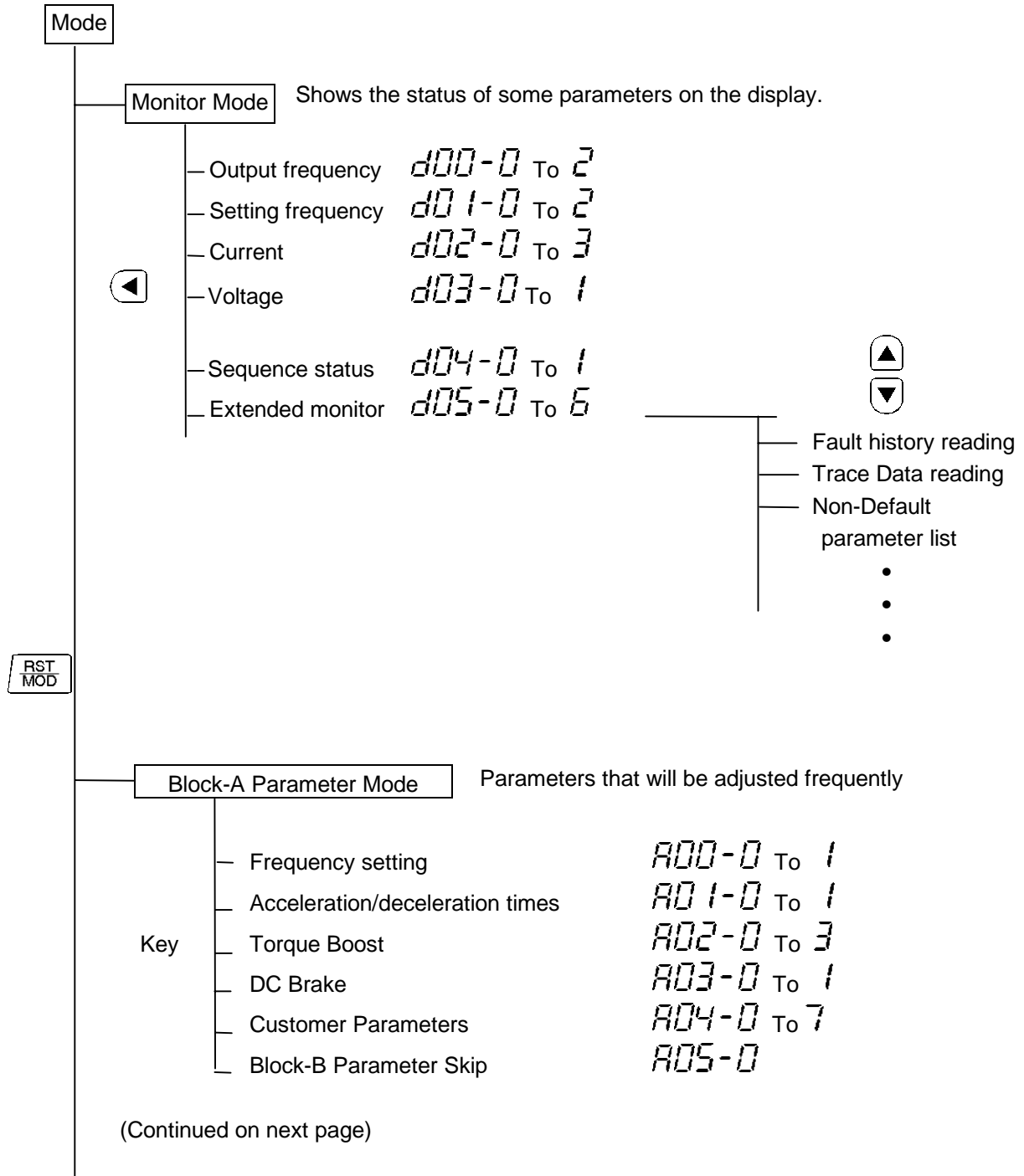

4. Operation Panel

(Continued from previous page)

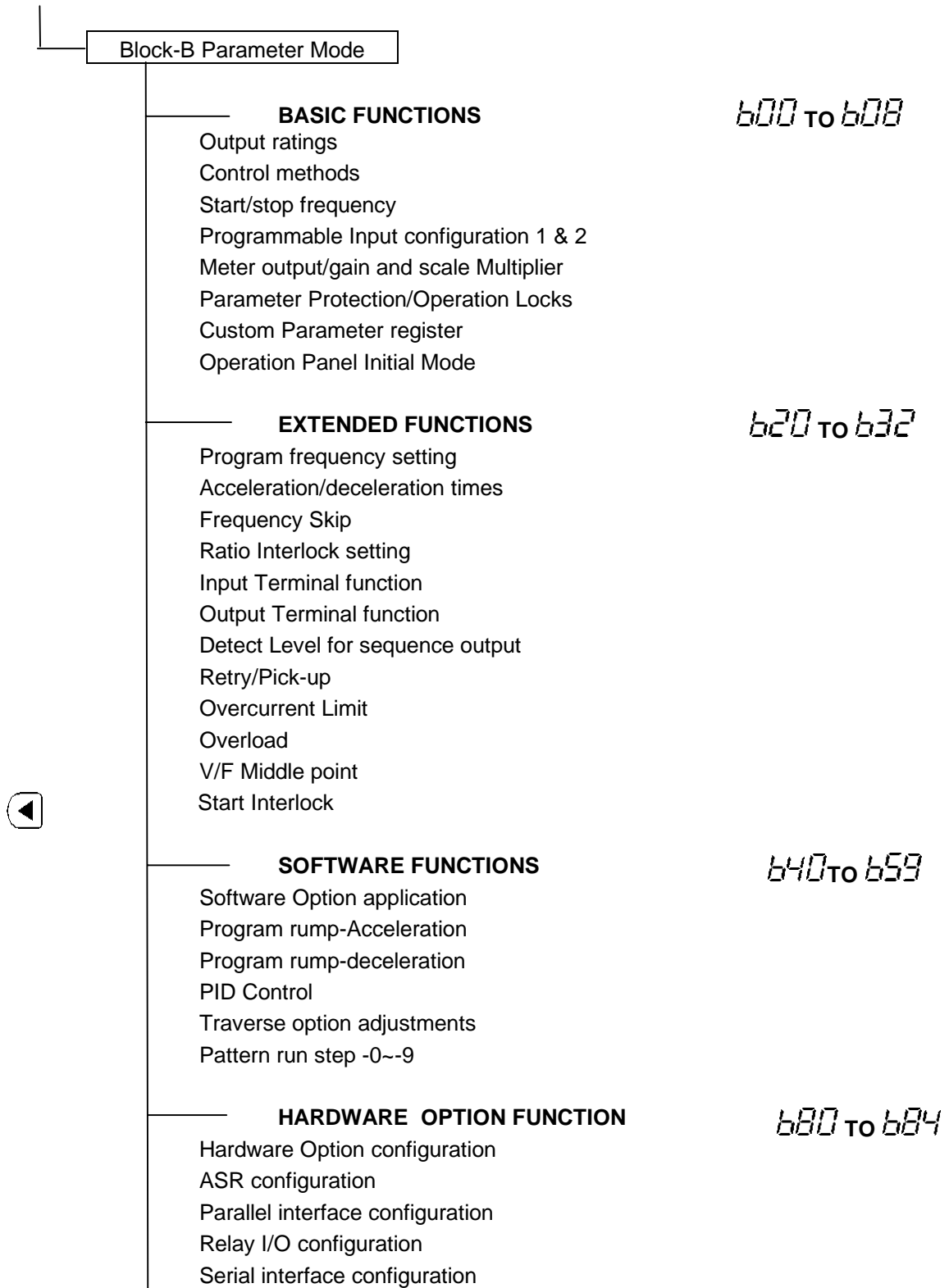

Fig. 4.2

Note: The VAT 3FD is default set so that only Basic Function Setting can be accessed. To access the Extended Function Setting, Software Option Setting, and Hardware Option Setting, change Parameter A05-0 (Parameter Skip).

4. Operation Panel

4-4 Reading Parameters in Monitor Mode

- 1) Refer to Table 6.1 for the Parameters that can be read in Monitor Mode.
- 2) The following is an example for reading the output current as a percentage and then showing the output frequency as Hz.

<Keys>	<Display>	<Explanation>
①	<div style="border: 1px solid black; padding: 5px; display: inline-block;">50.00</div> •Hz	<i>d00-0</i> : Output frequency
②	<div style="display: flex; align-items: center;"> <div style="margin-right: 5px;">◀</div> <div style="border: 1px solid black; padding: 5px; display: inline-block;">d01-0</div> </div>	Parameter block changes to <i>d01</i> block.
③	<div style="display: flex; align-items: center;"> <div style="margin-right: 5px;">◀</div> <div style="border: 1px solid black; padding: 5px; display: inline-block;">d02-0</div> </div>	Parameter block changes to <i>d02</i> block.
④	<div style="display: flex; align-items: center;"> <div style="margin-right: 5px;">▲</div> <div style="border: 1px solid black; padding: 5px; display: inline-block;">d02-1</div> </div>	Parameter number increases.
⑤	<div style="text-align: center;">↓</div> <div style="border: 1px solid black; padding: 5px; display: inline-block;">65.4</div> •%	After one second, the display will show the output current as a percentage.
⑥	<div style="display: flex; align-items: center;"> <div style="margin-right: 5px;">▼</div> <div style="border: 1px solid black; padding: 5px; display: inline-block;">d02-0</div> </div>	Parameter number decreases.
⑦	<div style="display: flex; align-items: center;"> <div style="margin-right: 5px;">◀</div> <div style="border: 1px solid black; padding: 5px; display: inline-block;">d01-0</div> </div>	Parameter block number decreases.
⑧	<div style="display: flex; align-items: center;"> <div style="margin-right: 5px;">◀</div> <div style="border: 1px solid black; padding: 5px; display: inline-block;">d00-0</div> </div>	Parameter block number decreases again.
⑨	<div style="text-align: center;">↓</div> <div style="border: 1px solid black; padding: 5px; display: inline-block;">50.00</div> •Hz	After one second, the display will show the output frequency as Hz.



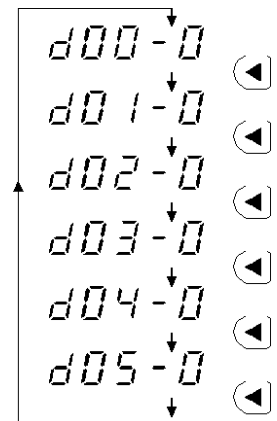









- 3) Press LCL
SET to show the Parameter Number on the display while monitoring.
- 4) Press ◀ repeatedly to return to *d00-0* from ⑤ as shown in the right sequence.
- 5) Hold down the ◀, ▲ or ▼ keys to scroll through Parameter Numbers at a high speed.





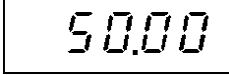
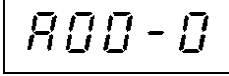

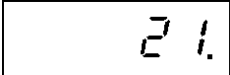
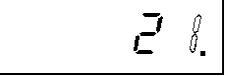

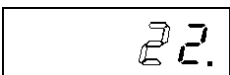
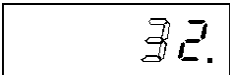
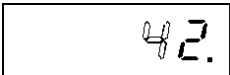
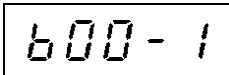
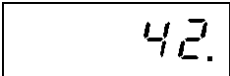



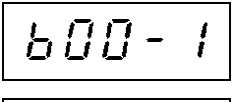

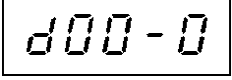

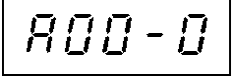

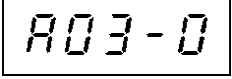

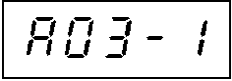

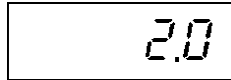
4. Operation Panel

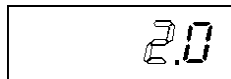

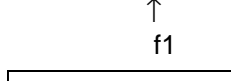
4-5 Reading and Adjusting Block-A & B Parameters

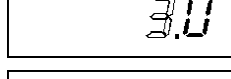
- 1) Refer to Tables 6.2 to 6.5 for the details of Block-A and B Parameters.
- 2) The following is an example for changing "Preset V/F Patterns (*b00-1*)" in Block-B Parameters, and then for changing "DC Braking Time (*r03-1*)" in Block-A Parameters.

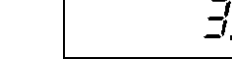
<Keys>	<Display>	<Explanation>
Change Parameter b00-1 (Preset V/F Patterns) from 21 (default value) to 42.		
<p>① </p> <p>② </p> <p>③  (Note 2)</p> <p>④ </p> <p>⑤ </p> <p>⑥  </p> <p>⑦ </p>	<p> ●Hz</p> <p></p> <p></p> <p>↓ ↑</p> <p></p> <p>↑</p> <p></p> <p>f0</p> <p></p> <p></p> <p>↑</p> <p>f1</p> <p></p> <p></p> <p></p> <p>↓ ↑</p> <p></p>	<p>(In Monitor Mode)</p> <p>Changes to the Block-A Parameter Setting Mode.</p> <p>Changes to the Block-B Parameter Setting Mode.</p> <p>The display will alternate between Parameter Number B00-1 and its present value 21.</p> <p>Enable the value to be changed. The value will display and the last digit (f0=1) will flicker indicating that it can be changed. The present value is: f0=1 (Ftrq=50Hz and Fmax=50Hz) f1=2 (Input voltage=200V) Note: Parameter B00-1 cannot be changed while the inverter is running.</p> <p>Change the last digit (f0) to 2. The setting is changed to Ftrq=60Hz and Fmax=60Hz.</p> <p>Move the cursor to the next digit (f1). The f1 digit will flicker.</p> <p>Change the f1 digit from 2 to 4. The input voltage setting is for 220V.</p> <p>Set the Parameter value to B00-1=42. The present value is: f0=2 (Ftrq=60Hz and Fmax=60Hz) f1=4 (Input voltage=220V)</p> <p>The display will alternate between Parameter Number B00-1 and the present value.</p>

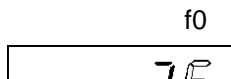
4. Operation Panel

<Keys>	<Display>	<Explanation>
Change Parameter A03-1 (DC Braking Time) from 2.0 (default value) to 3.5.		
8	 	(In Block-B Parameter Setting Mode)
	OHZ	
9	 	Changes to the Monitor Mode.
10	 (Note 2) 3 times 	Changes to the Block-A Parameter Setting Mode.
11	 	Increase the Parameter Block Number from A00 to A03.
12	 	Increase the Parameter Number.
		
12	 (Note 1) 	The display will alternate between Parameter Number A03-1 and the present value 2.0.
	 f1	Enable the value to be changed. The display still shows the value and the f1 digit will now flicker for change.
13	 	Change the f1 digit to 3.
14	 2 times 	Move the cursor to the next digit down (f0) via (f2). The f0 digit will now flicker.
	 f0	
15	 5 times 	Change the f0 digit from 0 to 5.
16	 	Set the Parameter value to A03-1=3.5.
		The display will alternate between Parameter Number and the present value. The operation panel is in Parameter Number Scanning Mode.
		











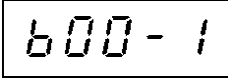
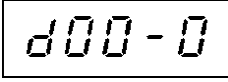

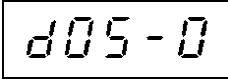

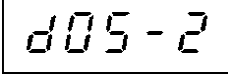

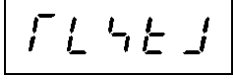
Note 1) When the Block Number is changed by , it will change to the next Block Number either up or down according to ,  pressed immediately before.

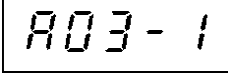
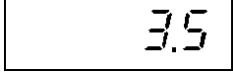
Note 2) If *Run* (RUN) displays while the parameter is being set in and 12, the parameter is one that can only be changed while the inverter is stopped. In this case, stop the drive first and then press  again.

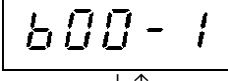
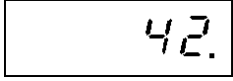
4. Operation Panel

4-6 Reading the Parameters That Have Been Changed (Non-Default Value Parameter List)

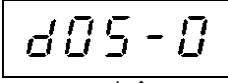
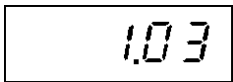

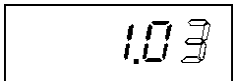







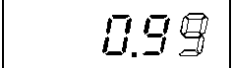

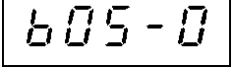

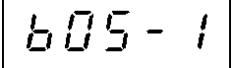

- 1) Monitor Parameter D05-2 is an entry into Non-Default Value Parameter Listing Mode in which the Block-A and B parameters that have been changed can be read.
- 2) In Non-Default Value Parameter Listing Mode, the display will show the Block-A and B Parameters that have different values from their default values. These Parameter values can also be changed in this mode.
- 3) The following is an example for reading B05-0 (FM Output Gain) and changing its value.

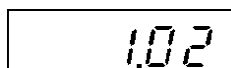
<Keys>	<Display>	<Explanation>
1	  	(In Block-B Parameter Setting Mode) Changes to the Monitor Mode.
2	 5 times 	Changes to the Extended Monitor Mode.
3	 2 times 	Go to d05-2 (Non-Default Value Parameter List Mode Entry).
4	 	After one second, [LSt] will display.
5	  ↓↑ 	Enter the Non-Default Value Parameter Listing Mode. The first Non-Default Value Parameter Number (in this case, A03-1) and its value will display alternately.
6	 • • •   ↓↑ 	The next Non-Default Value Parameter Number will display. If  ,  are pressed, the next Non-Default Value Parameter Number will increment or decrement and display.
7	  ↓↑   	The Parameter B05-0 (FM [Frequency Meter] Output Gain) will display. Select Parameter B05-0 so that the values can be changed.

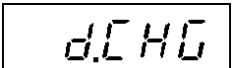
(Continued on next page)

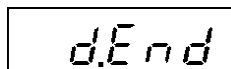
4. Operation Panel

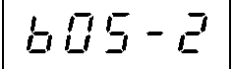
(Continued from previous page)

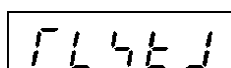
8	 4 times		Change the value from 1.03 to 0.99.
9			Complete the change of the value.
		 	
10			The next Non-Default Parameter Number will display.
		 	
11			The display will alternate between d.CHG and d.End, indicating the end of the Non-Default Value Parameter Number List.
		 	If  is pressed, the display will show the first Parameter again.
12		  	End Non-Default Value Parameter Number Listing Mode and return to the Monitor Parameter Select Mode. After one second, [LSt] will display.

4. Operation Panel

4-7 Customizing Block-B Parameter

- 1) Block-B Parameters can be assigned to any Block-A Parameter in the range of A04-0 to A04-7, and can be read and changed in the Block-A Parameter Setting Mode.
- 2) To assign the parameters, register the desired Block-B Parameter Number in the Block-B Parameters in the range B07-0 to B07-7.

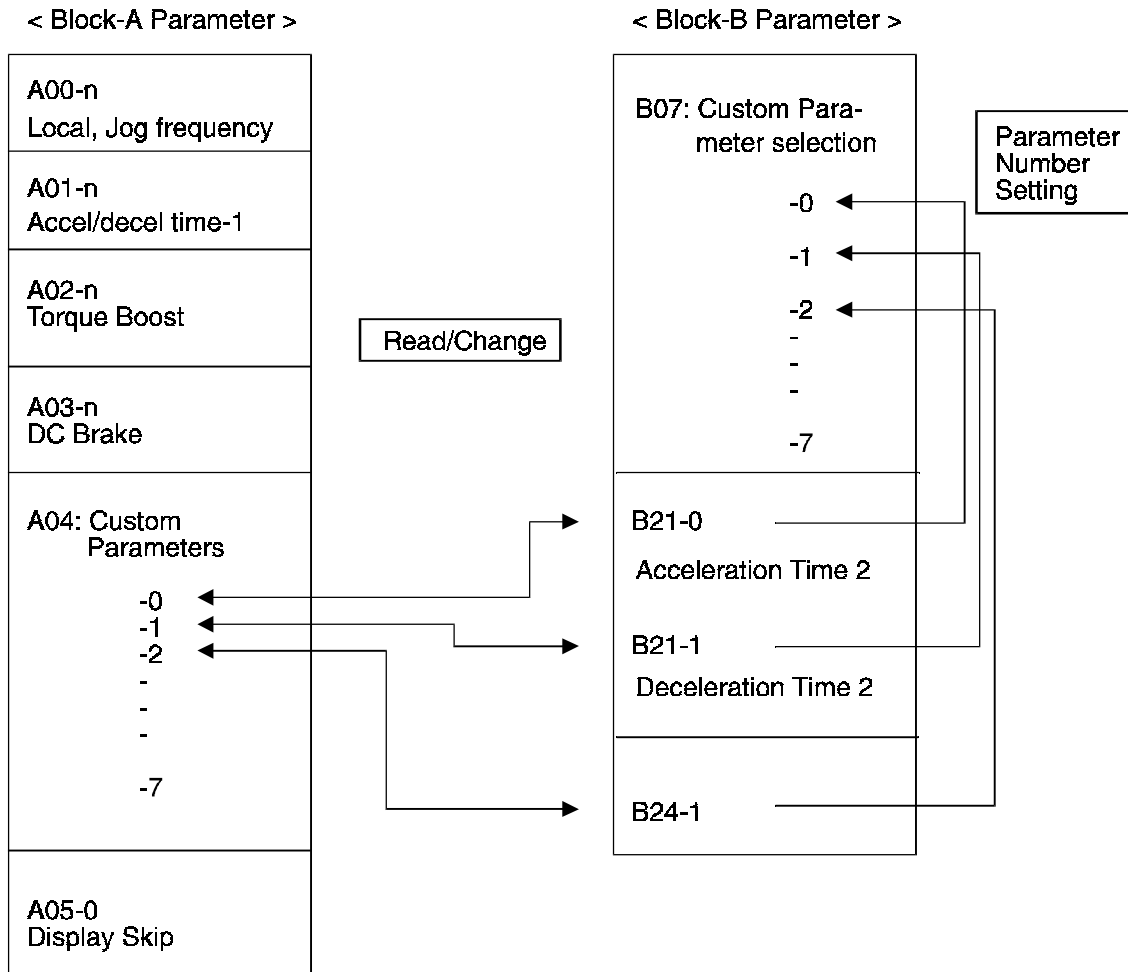

4. Operation Panel

3) The following is an example for changing the value of a Customer Parameter.

<Keys>	<Display>	<Explanation>
Register Parameter B23-1 on Parameter B07-0 (Custom Setting).		
<p>1</p> <div style="display: flex; justify-content: space-around; align-items: center;"> <div style="border: 1px solid black; padding: 2px; font-size: 8px;">RST MOD</div> <div style="font-size: 24px;">◀</div> </div> <div style="display: flex; justify-content: space-around; align-items: center; margin-top: 10px;"> <div style="font-size: 24px;">▲</div> <div style="font-size: 24px;">▼</div> </div>	<div style="border: 1px solid black; padding: 5px; width: 100px; margin: 0 auto;">607-0</div> <div style="text-align: center; margin: 5px 0;">↓ ↑</div> <div style="border: 1px solid black; padding: 5px; width: 100px; margin: 0 auto;">0.0</div>	<p>(Mode and parameter number change to B07-0)</p> <p>The display shows Parameter B07-0. The value 0.0 indicates that no Parameter has been registered on Parameter B07-0.</p>
<p>2</p> <div style="border: 1px solid black; padding: 2px; font-size: 8px; width: 50px; margin: 0 auto;">LCL SET</div>	<div style="border: 1px solid black; padding: 5px; width: 100px; margin: 0 auto;">0.0</div>	<p>Select Parameter Number B07-0.</p>
<p>3</p> <div style="font-size: 24px; margin: 0 auto;">▲</div>	<div style="border: 1px solid black; padding: 5px; width: 100px; margin: 0 auto;">0.1</div>	<p>Set the sub-number of B23-1.</p>
<p>4</p> <div style="font-size: 24px; margin: 0 auto;">◀</div>	<div style="border: 1px solid black; padding: 5px; width: 100px; margin: 0 auto;">0.1</div> <div style="text-align: center; margin: 5px 0;">↑ ↑ f1 f0</div>	<p>Move the cursor to the f1 digit.</p>
<p>5</p> <div style="font-size: 24px; margin: 0 auto;">▲</div> <p>hold down</p>	<div style="border: 1px solid black; padding: 5px; width: 100px; margin: 0 auto;">23.1</div>	<p>Hold down ▲ until f1 changes to 23.</p>
<p>6</p> <div style="border: 1px solid black; padding: 2px; font-size: 8px; width: 50px; margin: 0 auto;">LCL SET</div>	<div style="border: 1px solid black; padding: 5px; width: 100px; margin: 0 auto;">607-0</div> <div style="text-align: center; margin: 5px 0;">↑ ↑</div> <div style="border: 1px solid black; padding: 5px; width: 100px; margin: 0 auto;">23.1</div>	<p>Store the value.</p>

4. Operation Panel

Change Parameter B23-1 which has been assigned to A04-1.		
7	<div style="border: 1px solid black; display: inline-block; padding: 2px;">RST MOD</div> 2 times	<div style="border: 1px solid black; display: inline-block; padding: 5px; width: 80%;">A03-1</div>
8	▲	<div style="border: 1px solid black; display: inline-block; padding: 5px; width: 80%;">A04-0</div> ↓ ↑ <div style="border: 1px solid black; display: inline-block; padding: 5px; width: 80%;">1.000</div>
9	<div style="border: 1px solid black; display: inline-block; padding: 2px;">LCL SET</div>	<div style="border: 1px solid black; display: inline-block; padding: 5px; width: 80%;">1.000</div>
10	▼ 2 times	<div style="border: 1px solid black; display: inline-block; padding: 5px; width: 80%;">0.998</div>
11	<div style="border: 1px solid black; display: inline-block; padding: 2px;">LCL SET</div>	<div style="border: 1px solid black; display: inline-block; padding: 5px; width: 80%;">A04-0</div> ↓ ↑ <div style="border: 1px solid black; display: inline-block; padding: 5px; width: 80%;">0.998</div>

Enter the Block-A Parameter Setting Mode.

The Custom Parameter Number A04-0 will display.

The display will alternate between Parameter Number A04-0 and the value of Parameter Number B23-1. Parameter Number A04-0 is the same value as that of Parameter Number B23-1.

Parameter B23-1 can be changed now.

Change the value as required.

Store the new value.





Note 1) If the Parameters B07-n values are either 0.0 or any other undefined values, Parameters A04-n will be skipped during Parameter scan.

Note 2) If all the B07 Parameters are set at 0.0. all the A04 Parameter block will be skipped during Parameter scan.













4. Operation Panel

4-8 Reading Fault History

- 1) Parameter D05-0 is an entry into Fault History Mode.
- 2) The following is an example in which Fault History Mode is entered.

	<Keys>	<Display>	<Explanation>
1	 5 times	<div style="border: 1px solid black; padding: 2px; display: inline-block;">50.00</div> OHz ↓ <div style="border: 1px solid black; padding: 2px; display: inline-block;">D05-0</div> ↓ <div style="border: 1px solid black; padding: 2px; display: inline-block;">Err</div>	(Parameter D00-0 will display in the Monitor Mode.) Find Monitor Parameter D05-0. After 1 sec, the display will show [Err].
2	<div style="border: 1px solid black; padding: 2px; display: inline-block;">LCL SET</div>	↓ <div style="border: 1px solid black; padding: 2px; display: inline-block;">E00</div> ↓	Select and enter the Fault History Mode. Fault Number Emm and a Fault Code will display alternately. Scan the contents, using    keys.
3	<div style="border: 1px solid black; padding: 2px; display: inline-block;">LCL SET</div> or <div style="border: 1px solid black; padding: 2px; display: inline-block;">RST MOD</div>	<div style="border: 1px solid black; padding: 2px; display: inline-block;">D05-0</div> ↓ <div style="border: 1px solid black; padding: 2px; display: inline-block;">Err</div>	End Fault History Mode and return to the Monitor Mode.

- 3) The Fault History buffer is organized as follows.

Scan Keys	Fault sequence	Fault number	Display (Example)	Explanation	
  	Fault 1 (the latest)	E00	OL-3	Latest Fault Code Secondary Fault Code Output frequency at the fault Output current at the fault	
		E01	Pn-1		
		E02	14.20		OHz
		E03	4.7		OA
  	Fault 2	E10	U0-2	No secondary fault	
		E11	---		
		E12	50.00		OHz
		E13	3.9		OA
  	Fault 3	E20	---	Indicates that no fault is recorded.	
		E21	---		
		E22	---		
		E23	---		
  	Fault 4	E30	---		
		E31	---		
		E32	---		
		E33	---		

- 4) Set parameter B06-2 to 1 to clear the Fault History Buffer.
- 5) Refer to Appendix 3 for the fault codes and the details.