

## Chapter 5 Control Input/Output

### 5-1 Input/Output Terminal Function

The terminal block and input/output functions related to control are as shown in Tables 5.1, 5.2 and 5.3.

**Table 5.1 Terminal block functions**

Symbol	Meaning	Features
<b>RELAY INPUT (Digital inputs)</b>		
RY0	Relay input common	This is a common terminal for relay input signals specified below.
PSI1_ PSI5	Programmable input	These commands can be arbitrarily led to the input signal circuit in the control PCB through relay input selective setting.
EMS	Emergency stop	While the VAT 3FD is stopped, all operational commands are inhibited. If it is ON during operation, the VAT 3FD is led into a stopping sequence. As for stopping method, either ramp down stop or coast-to-stop is available. It is also possible to output this signal as a fault (FLT).
RESET	Fault reset	A faulty condition is reset. With this signal, a fault mode (FLT LED, FAULT relay operation) is turned off and operation is made possible again.
F RUN	Forward run	This is a command for forward run. A command for run/reverse mode or a selfhold mode can be selected. This feature is available in the remote operation mode (LCL LED unlighted).
<b>ANALOG INPUT</b>		
FSV	Voltage/frequency setting	This is a frequency setting input with a voltage range from 0 to 10V. A maximum frequency setting is available at a 10V input. This setting is valid when VFS of the internal relay signal is ON.
FSI	Current/frequency setting	This is a frequency setting input with a current range from 4 to 20mA. A maximum frequency setting is available at a 20mA input. This setting is valid when IFS of the internal relay signal is ON. The load resistance is 244W.
AUX	Auxiliary input	To be used for bias setting of $\pm 10V$ or main setting of $\pm 10V$ . For PID control, a feedback input mode is used.
COM	Analog input common	This is a common terminal for FSV and FSI signals.
<b>ANALOG OUTPUT</b>		
FM	Frequency meter	This is a voltage output signal for a frequency meter. In a standard mode, a 10V output is available at the maximum frequency. This output can be increased to 0.2 to 2.0 times. (Max. output is, however, approximately 11 volts.) Internal parameters other than those of frequency can also be output.
AM	Ammeter	This is a voltage output signal for ammeter. In standard arrangements, an output of 5V is available for the rated current. An output of 0.2 to 2.0 times of 5V is also available. Internal parameters other than those of current can also be output.
COM	Analog output common	This is a common terminal for a frequency meter and ammeter.
P10	FSV source	This is a 10V source used when a frequency setter is connected to the FSV input circuit. The frequency setter to be used should be a variable resistor of 2W and 2K $\Omega$ .
<b>RELAY OUTPUT (Digital outputs)</b>		
RC, RA	RUN	This is a contact to be ON during operation or DC braking.
FC, FA, FB	Fault	These contacts function when a fault occurs (when the FLT lamp is lighted). When a fault occurs, the section FA-FC is closed and the section FB-FC is open.
ATNC ATNE	Frequency attainment (ATN)	An open-collector signal to be turned on when the output frequency has attained the preset setting level.

## 5. Control Input/Output

**Table 5.2 Relay input signals in control section**

Symbol	Meaning	Features																																				
R RUN	Reverse run	This is a command for reverse run. A command of reverse run mode is available in the run/reverse mode.																																				
F JOG	Forward inching	These are inching commands. If this signal is ON while F RUN or R RUN is OFF, operation then conforms to the setting of inching (A00-1) made within the control circuit. For stoppage, either ramp down stop or coast-stop is available.																																				
R JOG	Reverse inching																																					
HOLD	Hold	This is a stop signal generated when the setting is to be the self-hold mode during the operating mode. The VAT 3FD stops with this signal turned off. Input of RUN or R RUN can be held with this signal turned on.																																				
BRAKE	DC brake	DC brake can be operated with this signal.																																				
PICK-UP	Pick-up	While this signal is ON, pick-up operation is effected as soon as F RUN or R RUN is ON.																																				
VFS	Voltage setting	Frequency setting is made with an input from FSV.																																				
IFS	Current setting	Frequency setting is made with an input from FSI.																																				
PROG	Program setting	Used for multiple setting. Selection of 8 steps (PROG0_PROG7) is made with S0_S2.																																				
CFS	CPU setting	The setting from the communication option is selected.																																				
S0_S2	Program setting selection	When PROG is ON, Program frequency 0_7 are selected. <table style="margin-left: auto; margin-right: auto; border-collapse: collapse;"> <tr> <td></td> <td>Prog.0</td> <td>Prog.1</td> <td>Prog.2</td> <td>Prog.3</td> <td>Prog.4</td> <td>Prog.5</td> <td>Prog.6</td> <td>Prog.7</td> </tr> <tr> <td>S0</td> <td>0</td> <td>1</td> <td>0</td> <td>1</td> <td>0</td> <td>1</td> <td>0</td> <td>1</td> </tr> <tr> <td>S1</td> <td>0</td> <td>0</td> <td>1</td> <td>1</td> <td>0</td> <td>0</td> <td>1</td> <td>1</td> </tr> <tr> <td>S2</td> <td>0</td> <td>0</td> <td>0</td> <td>0</td> <td>1</td> <td>1</td> <td>1</td> <td>1</td> </tr> </table> <p style="text-align: center;">In this case [0] denotes OFF and [1] denotes ON.</p>		Prog.0	Prog.1	Prog.2	Prog.3	Prog.4	Prog.5	Prog.6	Prog.7	S0	0	1	0	1	0	1	0	1	S1	0	0	1	1	0	0	1	1	S2	0	0	0	0	1	1	1	1
	Prog.0	Prog.1	Prog.2	Prog.3	Prog.4	Prog.5	Prog.6	Prog.7																														
S0	0	1	0	1	0	1	0	1																														
S1	0	0	1	1	0	0	1	1																														
S2	0	0	0	0	1	1	1	1																														
I PASS	Ratio interlock bypass	Ratio interlock operation is bypassed.																																				
C SEL	Ramp selection	Accel./decel. ramp performance is switched over. Accel./decel. time 2 is available with ON, and accel./decel. time 1 is available with OFF.																																				
COP	CPU operation	Used when parallel input or serial communication.																																				
FUP	Frequency increment	To raise the internal frequency setting.																																				
FDW	Frequency decrement	To lower the internal frequency setting.																																				

**Table 5.3 Relay output signals in control section**

Symbol	Meaning	Features
RUN	Run	This signal is ON during operation or DC braking. (This is the same signal as that of the standard RUN relay output.)
FLT	Fault	ON when a fault occurs. (The same signal as that of the standard FAULT relay output.)
RDY	Ready	Operation is possible while this signal is ON.
LCL	Direct	ON when the operation mode is DIRECT (operation attempted from the operation unit.)
REV	Reverse	ON when reverse run or reverse inching command is received. This signal is held even during the operation stopping.
I DET	Current detection	ON when the current exceeds the level set by data No. B26-1.
ATN	Frequency attained	ON when the output frequency has reached the setting input level.
SPD1_2	Speed detection	ON when the frequency exceeds the level set by data Nos. B26-2 and B26-3.
ACC	Acceleration	On while the frequency is raised according to frequency setting.
DCC	Deceleration	ON while the frequency is lowered according to frequency setting.
EC0_3	Error code	When a fault occurs, the content of this fault is indicated by a 4-bit code.
MC	MC	ON while precharge magnetic contactor is closed.

## 5. Control Input/Output

### 5-2 Control Input/Output Circuit

Examples of the control Input/Output circuit wiring are shown in table 5.4. The precautions must be observed during wiring.

**Table 5.4 Control input/output circuit**

Function	Example of wirings	Precautions																							
Relay input		<ol style="list-style-type: none"> <li>1. Wiring must not be longer than 50m.</li> <li>2. The allowable leakage current is 5mA.</li> <li>3. Use a minute current contact.</li> <li>4. Do not connect to the analog input/output.</li> </ol>																							
Analog input and P10 output		<ol style="list-style-type: none"> <li>1. Use 2kΩ/2W rating setter for the external variable resistor.</li> <li>2. The maximum input rating of FSV is -0.0 to +10.5V.</li> <li>3. Use a shielded wire shorter than 30m for the wiring.</li> <li>4. For shield connections, open the mate side, and connect to COM terminal on the VAT 3FD side.</li> <li>5. The maximum input rating for FSI is 0 to +21mA or 0 to +5.25V.</li> <li>6. Do not connect to the relay input.</li> </ol>																							
Analog output		<ol style="list-style-type: none"> <li>1. Use a 10V full scale meter (impedance: 10kΩ or higher).</li> <li>2. The maximum output current is 1mA.</li> <li>3. Use a shielded wire shorter than 30m for the wiring.</li> <li>4. For shield connections, open the mate side, and connect to COM terminal on the VAT 3FD side.</li> </ol>																							
Relay output		<ol style="list-style-type: none"> <li>1. Use within the rated range shown on the left.</li> <li>2. The wire must be shorter than 50m</li> </ol> <table border="1" style="margin-top: 10px; width: 100%; border-collapse: collapse; text-align: center;"> <thead> <tr> <th></th> <th>RUN</th> <th>FLT</th> </tr> </thead> <tbody> <tr> <td rowspan="3">Rated capacity (resistance load)</td> <td>250VAC</td> <td>125VAC</td> </tr> <tr> <td>1A</td> <td>0,4A</td> </tr> <tr> <td>30VDC</td> <td>30VDC</td> </tr> <tr> <td rowspan="2">Max. voltage</td> <td>250VAC</td> <td>250VAC</td> </tr> <tr> <td></td> <td>220VDC</td> </tr> <tr> <td>Max. current</td> <td>1A</td> <td>1A</td> </tr> <tr> <td rowspan="2">Switching capacity</td> <td>100VA</td> <td>50VA</td> </tr> <tr> <td>100W</td> <td>60W</td> </tr> </tbody> </table>		RUN	FLT	Rated capacity (resistance load)	250VAC	125VAC	1A	0,4A	30VDC	30VDC	Max. voltage	250VAC	250VAC		220VDC	Max. current	1A	1A	Switching capacity	100VA	50VA	100W	60W
	RUN	FLT																							
Rated capacity (resistance load)	250VAC	125VAC																							
	1A	0,4A																							
	30VDC	30VDC																							
Max. voltage	250VAC	250VAC																							
		220VDC																							
Max. current	1A	1A																							
Switching capacity	100VA	50VA																							
	100W	60W																							
Open collector output																									

## 5. Control Input/Output

### 5-3 Sequence Input Logic

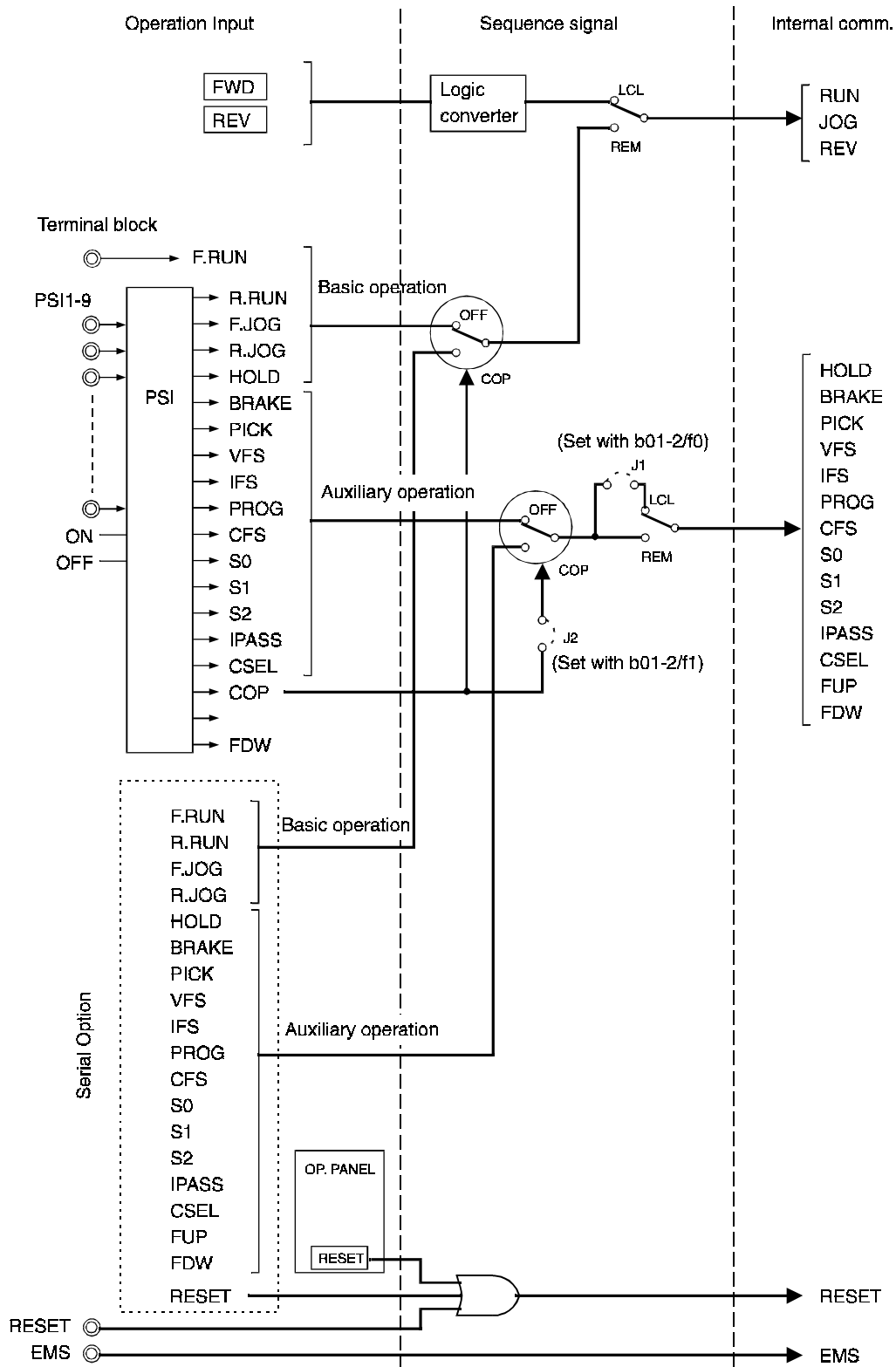

Fig 5.1 Sequence input logic

## 5. Control Input/Output

### 5-4 Changing of Terminal Functions

The programmable input terminals (PSI1 to PSI5, PSI6 to PSI9 added with UADOPTR option) can be connected to random internal commands. The internal state can be connected to the RUN terminal, ATN terminal and PSO1 to PSO4 terminals of the "R" option to lead in the ON/OFF signal.

(1) Relay input terminal assignment and monitoring

The parameters can be assigned to the terminal block as shown in Fig. 5.2 according to the parameter Nos. B03-0 to 8 and B04-0 to 8. Each parameter can be fixed to ON (set value to 16) or OFF (set value to 0). Fig. 5.3 shows the case when the ON state of each parameter is shown on the indicator. This monitoring is performed with D04-0. F.RUN, R.RUN, F.JOG and R.JOG are displayed with a combination of RUN, REV and JOG converted into an internal command.

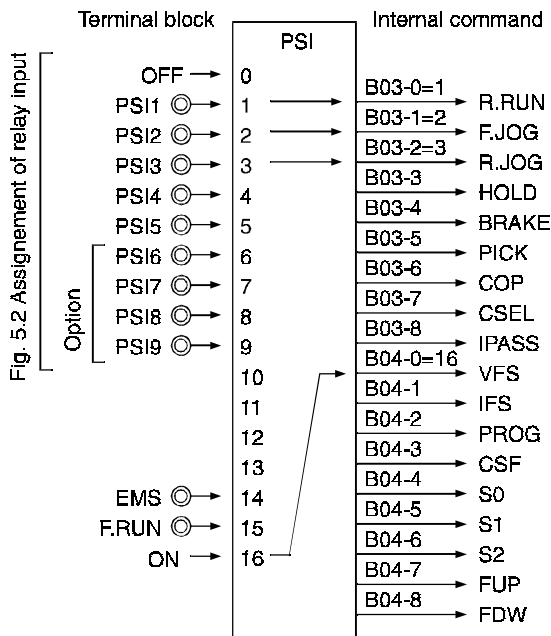

Fig. 5.2 Assignment of relay input

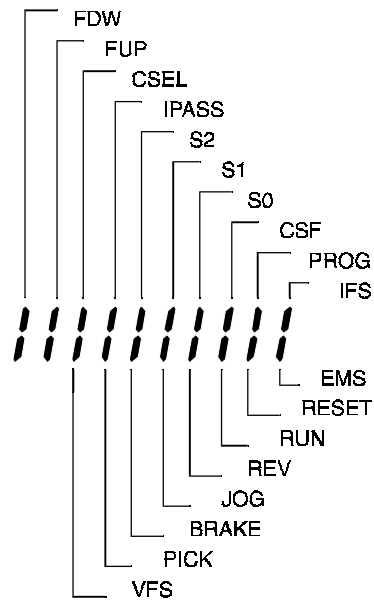

Fig. 5.3 Sequence input monitor

## 5. Control Input/Output

### (2) Relay output terminal assignment and monitoring

The ON/OFF of the internal signals can be output to the RA-RC terminals and ATNC-ATNE terminals as shown in Fig. 5.4 with the parameter Nos. B25-1 and -2. The ON/OFF of each signal can be monitored as shown in Fig. 5.5. This monitoring is executed with D04-1.

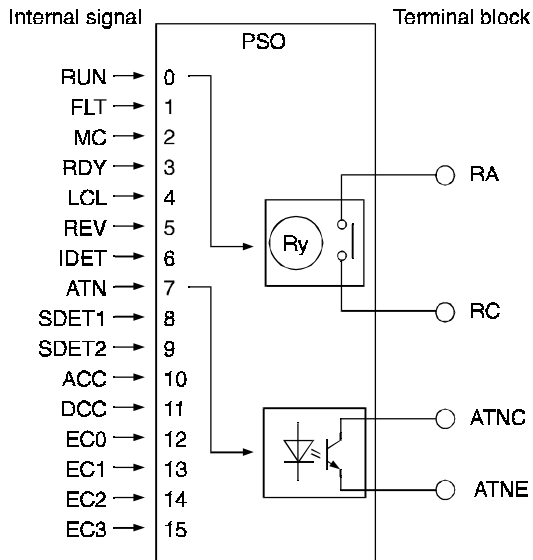

Fig. 5.4 Assignment of relay output

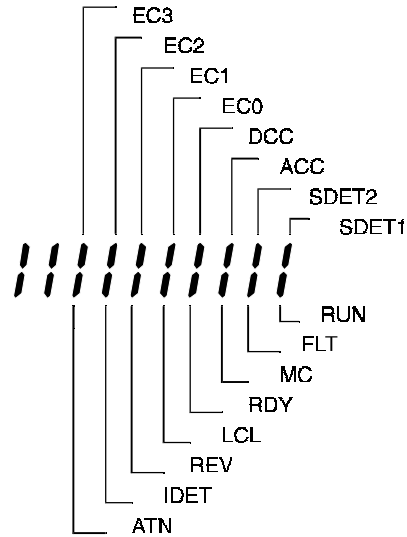

Fig. 5.5 Sequence output monitor

### (3) FM/AM terminal parameters

Each parameter can be assigned to the FM/AM terminal as shown in Fig. 5.6 with parameter No. B25-0.

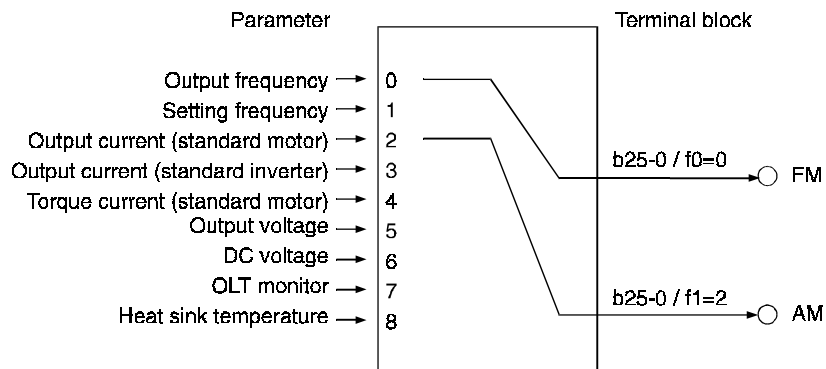

Fig. 5.6 Assignment to FM/AM terminals

## 6. Control Functions and Parameter Settings

### Chapter 6 Control Functions and Parameter Settings

#### 6-1 Monitor Parameters

The monitor mode sequentially displays the frequency, power supply, etc., parameters recognized by the VAT 3FD.

A list of parameters that can be monitored are shown in Table 6.1.

**Table 6.1 Monitor parameters**

No.	Parameter	Unit	Remark
D00 - Output frequency			
0	Output frequency in Hz	Hz	<i>OFF</i> will display when the gate is closed. <i>br</i> displays while the DC brake is in action.
1	Output frequency in %	% (Note 1)	
2	Output frequency in AS	AS(Note 2)	
D01 - Frequency setting			
0	Setting frequency in Hz	Hz	The currently selected frequency setting value is displayed.
1	Setting frequency in %	% (Note 1)	
2	Setting frequency in AS	AS(Note 2)	
D02 - Output current			
0	Output current Amps	A	<i>OFF</i> will display when the gate is closed. <i>br</i> displays while the DC brake is in action. OLT functions when this value reaches 100%.
1	Output current in %	%	
2	Overload (OLT) monitor	%	
3	Heatsink temperature	°C	
D03 - Voltage			
0	DC voltage	V	Displays the voltage of the DC link circuit in the main circuit. Displays output voltage command. The display may differ from the actual output voltage. It depends on the power supply voltage. <i>OFF</i> will display when the gate is closed.
1	Output voltage command	V	
D04 - Sequence Status			
0	Input		The ON/OFF state of the internal parameters will display. The correspondence of each LED segment and signal is shown in Figs. 5.3 and 5.5.
1	Output		
D05 - Extended Monitor			
0	Fault history reading entry		The fault history reference mode will display when <b>SET</b> is pressed. The trace data reference mode will display when <b>SET</b> is pressed. The mode for referring to and changing parameters that differ from the default value will display when <b>SET</b> is pressed. The cumulative time after product shipment will be counted and displayed. The cumulative run time after product shipment will be counted and displayed. Display of CPU version. Display of ROM version.
1	Trace data entry		
2	Non-default value parameter list mode entry		
3	Cumulative conductivity time	Hrs	
4	Cumulative run time	Hrs	
5	CPU version		
6	ROM version		

## 6. Control Functions and Parameter Settings

---

No.	Parameter	Unit	Remark
D06 - Pattern run monitor (displays during pattern run)			
0	Step No.		The current step No. will display.
1	Remaining time	Sec.	The remaining time of the current step will display.
D07 - Speed detection monitor (displays during use of ASR option)			
0	Detection speed in Hz unit display	Hz	The motor synchronous frequency will display.
1	Detection speed in % unit display (Note 1)	%	% of the maximum frequency
2	Detection speed AS display (Note 2)	[AS]	

**Note 1)** % display to max. frequency.

**Note 2)** The AS values in Frequency Monitor Mode are frequency values multiplied by the AS constant set in B05-2. This is default set to 30.0, representing the speed of a 4-pole motor in rpm.

## 6. Control Functions and Parameter Settings

### 6-2 Block A Parameters

The parameters used most frequently have been grouped in Block A.

By setting the Block B parameters B00-1 to -5 and the Block A parameters, the VAT 3FD can be operated easily.

The list of Block A parameters is shown in Table 6.2.

**Table 6.2 Block A parameters**

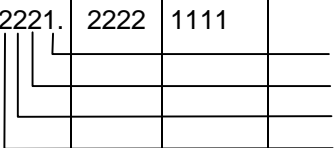

\* The parameters marked (1) can be reflected to the operation immediately.

No.	Parameter	Default	Min.	Max.	Unit	Function
A00 - Frequency Setting						
0	Local Frequency Setting (1)	10.00	0.10	Fmax	Hz	This is the frequency set from the operation panel. This is the frequency setting for jogging.
1	Frequency setting for jogging (1)	8.00	0.10	Fmax	Hz	
A01 - Acceleration/Deceleration Times						
0	Acceleration time - 1	10.0	0.1	6000.0	S	The value can be displayed in units of 0.1 or 10 times as set on B21-5 (Default value is 1.0.).
1	Deceleration time - 1	20.0	0.1	6000.0	S	
A02 - Torque Boost						
0	Torque boost voltage(Note 1)	3.0	0.0	20.0	%	This is the voltage at 0Hz. This is the voltage at half of Ftrq (Ftrq/2).
1	Reduced voltage for square-law torque	0.0	0.0	25.0	%	
2	Auto torque boost gain	0.0	0.0	20.0		This is the motor's rated slip.
3	Slip compensation gain	0.00	0.00	5.00	%	
A03 - DC Brake						
0	DC braking voltage	5.0	0.1	20.0	%	
1	DC braking time	2.0	0.0	20.0	S	
A04 - Custom parameters						
0	Custom - 0					Set the parameter Nos. to be displayed in this block in B07-0~7. This block displays when the above settings are not made.
1	- 1					
2	- 2					
3	- 3					
4	- 4					
5	- 5					
6	- 6					
7	- 7					
A05 - Block B Parameter skip						
0	Skip selector		2221.	2222	1111	 <p>f0: Basic function f1: Extended function f2: Software Options f3: Hardware Options = 1: Display, 2: Skip <b>Note)</b> Skip on all the four is disabled.</p>

**Note 1)** The default values may differ from the values in the table depending on the inverter type.

## 6. Control Functions and Parameter Settings

### A00-0 Local frequency setting

This is the frequency setting selected in the local operation mode (LCL lamp lit). The output frequency changes immediately according to the   operation. This is the setting value for the remote operation mode (LCL lamp not lit) when the VFS, IFS and PROG are off

### A00-1 Frequency setting for jogging

This is the frequency setting selected when executing jogging run with the sequence command F JOG or R JOG. An acceleration/deceleration time exclusive for jogging can be set with parameters B21-2 and 3.

- B21-2: Jogging acceleration ramp up time
- B21-3: Jogging deceleration ramp down time

### A01-0, 1 Acceleration/deceleration times

### A03-0, 1 DC brake

### B02-0, 1 Start, stop frequencies

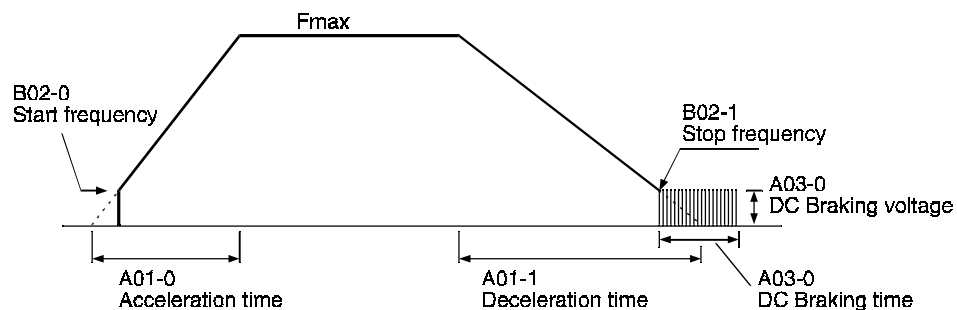

Set the acceleration/deceleration times with formula (1). the inverter may trip if the set time is too short.

Increase the DC Braking voltage in units of 1% or less at a time while monitoring the output current. The inverter may trip if the setting is too high.

## 6. Control Functions and Parameter Settings

### Acceleration/deceleration time setting

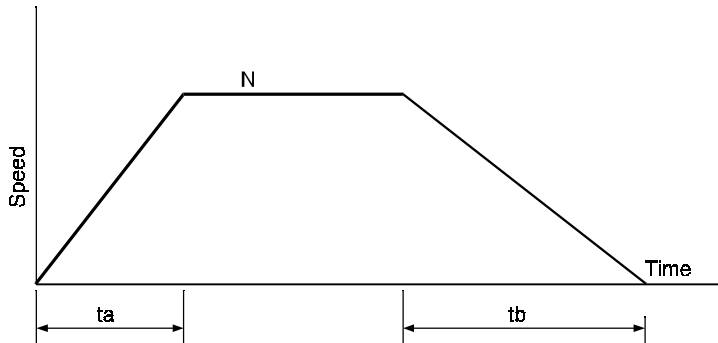

$$\text{Deceleration time } t_a = \frac{J \cdot N}{9,56 (T_{MA} + T_L)} \dots \text{Formula 1}$$

$$\text{Deceleration time } t_b = \frac{J \cdot N}{9,56 (T_{MB} + T_L)} \dots \text{Formula 2}$$

$$J = J_M + J_L \quad [\text{kg} \cdot \text{m}^2]$$

Where:  $J_M$ : Motor inertia

$J_L$ : Motor inertia (Converted to motor shaft.)

$N$  : Rated speed [rpm]

Where: Speed at  $F_{trq}$

$T_{MA}$  : Motor drive torque [N.m]

$$(T_{MA} = \frac{P}{0,1047 \cdot N} \quad \text{Where: } P \text{ is motor capacity [kW]})$$

$T_L$  : Load torque [N.m]

$T_{MB}$  : Motor braking torque [N.m]

$$T_{MB} = T_{MA} \cdot (\text{dynamic braking capacity [kW]}/$$

$$\text{motor capacity [kW]}) \cdot \frac{1}{0.8}$$

Note, the dynamic braking capacity follows the equations below:

For 200V system

$$\text{Dynamic braking capacity} = \frac{148.2}{\text{DBR resistance value}} \quad [\Omega][\text{kW}]$$

For 400V system

$$\text{Dynamic braking capacity} = \frac{593}{\text{DBR resistance value}} \quad [\Omega][\text{kW}]$$

## 6. Control Functions and Parameter Settings

A02-0	<b>Torque Boost Voltage</b>
A02-1	<b>Reduced voltage for square-law torque</b>

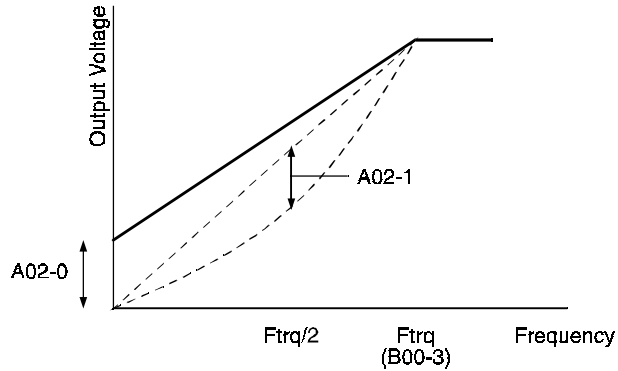

The torque Boost is set with boost voltage at 0Hz  
 The reduced voltage for square-law torque is set with the reduced voltage at  $F_{trq}/2$ .  
 If both A02-0 and A02-1 are set, the voltage will be an added voltage as shown below.

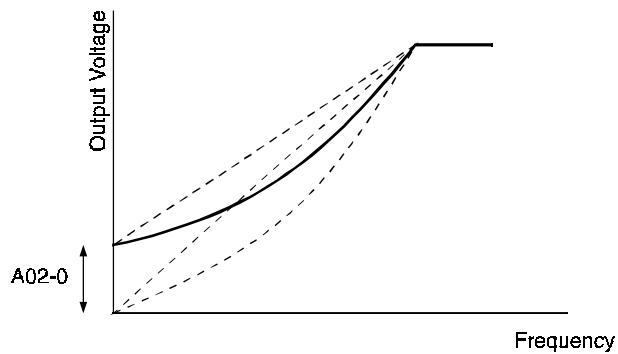

A02-2	<b>Auto torque boost gain</b>
-------	-------------------------------

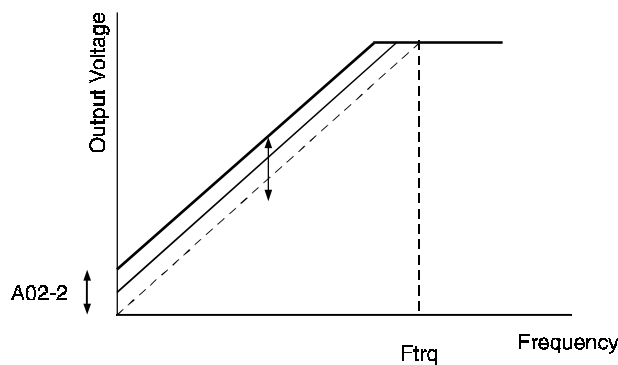

The auto torque boost controls the output voltage according to the magnitude of the load  
 Set the boost voltage (normally 3 to 5%) of when the rated output current is being output.  
 When this parameter is set, A02-0 and 1 (boost and reduced voltage for square-law torque functions) will not work.

Set 0 when not using auto torque boost.

When auto torque boost is used, the output voltage will drop with light loads.

The rotation may become unstable or the inverter may trip if the setting is too high.

## 6. Control Functions and Parameter Settings

A02-3

### Slip compensation gain

Set the slip [%] during the motor rated load.

The output frequency is controlled according to the motor load torque as shown below.

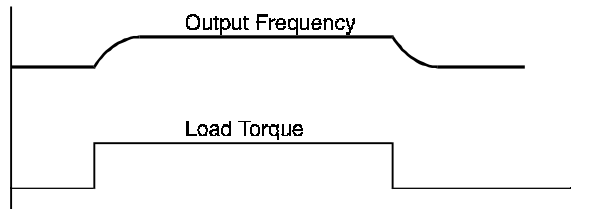

The motor rotation may become unstable if the setting is too high

A04-0~7

### Custom parameters

B07-m: The parameters selected with the custom parameter selection can be displayed.

Refer to section 4-7 for details.

A05-0

### Parameter block skip

The parameter display is skipped for each function in the basic functions, extended functions, software option functions and hardware option functions.

Unnecessary displays can be reduced with this parameter, allowing operation to be simplified.

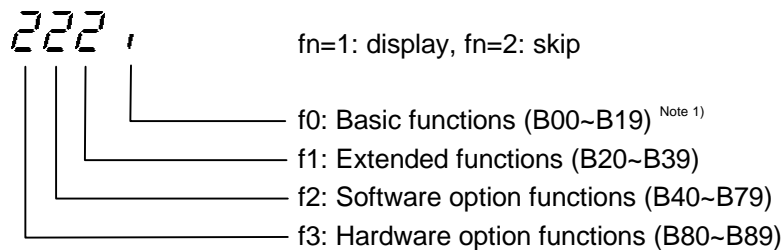

**Note 1)** The range of the parameter Nos. per function unit is shown. Parameter Nos. not used currently are included for future use.

**Note 2)** 2222 (all skip) cannot be set.

## 6. Control Functions and Parameter Settings

**Example)** A05-0=2121: Skip extended function and hardware option functions.

The following display with the parameter selection operation using the  key.

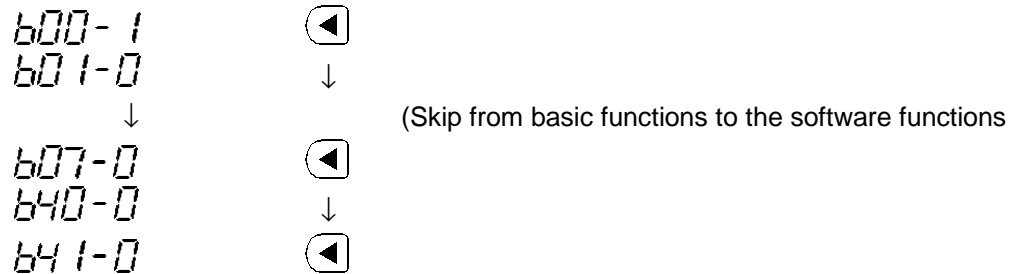

### <Reference>

Some parameters have functions assigned for each digit (A05-0, B00-1, etc.). The functions of each digit of these kinds of parameters are explained with the symbols f0 to f3 as shown below.

f3 f2 f1 f0  
88888

### 6-3 Block B Parameters

The block B parameters are divided into the basic functions, extended functions, software option functions and hardware option functions.

#### 6-3-1 Basic Function Settings

This is a group of parameters that determines the ratings and basic functions of the inverter. A list of basic function parameters is shown in Table 6.3.

## 6. Control Functions and Parameter Settings

**Table 6.3 (1) Block-B parameters - Basic Function**

(1) can be reflected to the operation immediately. (2) can only be changed while the drive is at a stop.

No.	Parameter	Default	Min.	Max.	Unit	Function																																																			
B00 - Output ratings (2)																																																									
1	Pre-set V/F patterns	21.	10	59		<p>The following patterns (combinations of the base and maximum frequencies) are available.</p> <p>f0: Max frequency &amp; base frequency selector</p> <table border="1" style="margin-left: auto; margin-right: auto;"> <thead> <tr> <th style="text-align: center;">f0 value</th> <th style="text-align: center;">Ftrq (Hz)</th> <th style="text-align: center;">Fmax (Hz)</th> </tr> </thead> <tbody> <tr> <td style="text-align: center;">0</td> <td style="text-align: center;">Free setting and B00-3</td> <td style="text-align: center;">on B00-2</td> </tr> <tr> <td style="text-align: center;">1</td> <td style="text-align: center;">50</td> <td style="text-align: center;">50</td> </tr> <tr> <td style="text-align: center;">2</td> <td style="text-align: center;">60</td> <td style="text-align: center;">60</td> </tr> <tr> <td style="text-align: center;">3</td> <td style="text-align: center;">50</td> <td style="text-align: center;">60</td> </tr> <tr> <td style="text-align: center;">4</td> <td style="text-align: center;">50</td> <td style="text-align: center;">75</td> </tr> <tr> <td style="text-align: center;">5</td> <td style="text-align: center;">50</td> <td style="text-align: center;">100</td> </tr> <tr> <td style="text-align: center;">6</td> <td style="text-align: center;">60</td> <td style="text-align: center;">70</td> </tr> <tr> <td style="text-align: center;">7</td> <td style="text-align: center;">60</td> <td style="text-align: center;">80</td> </tr> <tr> <td style="text-align: center;">8</td> <td style="text-align: center;">60</td> <td style="text-align: center;">90</td> </tr> <tr> <td style="text-align: center;">9</td> <td style="text-align: center;">60</td> <td style="text-align: center;">120</td> </tr> </tbody> </table> <table border="1" style="margin-left: auto; margin-right: auto;"> <thead> <tr> <th style="text-align: center;">f1 Value</th> <th style="text-align: center;">200V System</th> <th style="text-align: center;">400V System</th> </tr> </thead> <tbody> <tr> <td style="text-align: center;">1</td> <td style="text-align: center;">190V</td> <td style="text-align: center;">380V</td> </tr> <tr> <td style="text-align: center;">2</td> <td style="text-align: center;">200V</td> <td style="text-align: center;">400V</td> </tr> <tr> <td style="text-align: center;">3</td> <td style="text-align: center;">210V</td> <td style="text-align: center;">415V</td> </tr> <tr> <td style="text-align: center;">4</td> <td style="text-align: center;">220V</td> <td style="text-align: center;">440V</td> </tr> <tr> <td style="text-align: center;">5</td> <td style="text-align: center;">230V</td> <td style="text-align: center;">460V</td> </tr> </tbody> </table> <p>f1: Rated input voltage</p> <p>When these parameter has been changed, the output voltage data will automatically be changed to the same voltage. (Excluding 0)</p>	f0 value	Ftrq (Hz)	Fmax (Hz)	0	Free setting and B00-3	on B00-2	1	50	50	2	60	60	3	50	60	4	50	75	5	50	100	6	60	70	7	60	80	8	60	90	9	60	120	f1 Value	200V System	400V System	1	190V	380V	2	200V	400V	3	210V	415V	4	220V	440V	5	230V	460V
f0 value	Ftrq (Hz)	Fmax (Hz)																																																							
0	Free setting and B00-3	on B00-2																																																							
1	50	50																																																							
2	60	60																																																							
3	50	60																																																							
4	50	75																																																							
5	50	100																																																							
6	60	70																																																							
7	60	80																																																							
8	60	90																																																							
9	60	120																																																							
f1 Value	200V System	400V System																																																							
1	190V	380V																																																							
2	200V	400V																																																							
3	210V	415V																																																							
4	220V	440V																																																							
5	230V	460V																																																							
2	Maximum output frequency (Fmax)	50.0	3.0	440.0	Hz	These will automatically be adjusted to the values set on Parameter B00-1/f0 except when it is set to 0.																																																			
3	Base frequency (Ftrq)	50.0	0.0	440.0	Hz																																																				
4	Output voltage	200.	0.	460.	V	If this is set to 0, DC-AVR is not activated and the input voltage equals the output voltage at Ftrq. If this is set at a value other than 0, AVR is enabled and the output voltage will be the setting value at Ftrq. When the B00-1/ f1parameter is changed, the setting value is automatically changed to the value defined at f1. Values exceeding rated input voltage cannot be set.																																																			
5	Motor rated current (according with either UADX,, or UADVX,, type units)	Drive rated current 72.0	Max.: Unit rating Min.: Unit rating ×0.3		A	The value of this parameter will be the basis for overcurrent Limit, Overload trip (OLT), % Current Display and Meter Output.																																																			
6	Carrier frequency	4.	3	8.	kHz	( for UADVX... units note 1)																																																			

**Note 1)** If the output current reaches 90% of inverter's rated current, or if the heatsink reaches 70°C, the carrier frequency is automatically set to 4KHz

## 6. Control Functions and Parameter Settings

Table 6.3 (2)

No.	Parameter	Default	Min.	Max.	Unit	Function
<b>B01 - Control Methods (2)</b>						
0	Run/Stop methods	1221.	1111.	3223.		<ul style="list-style-type: none"> <li>f0: Run command method               <ul style="list-style-type: none"> <li>= 1: F.RUN, R.RUN</li> <li>= 2: RUN, REV</li> <li>= 3: Pulse Switchover (Pulse inputs for F.RUN and R.RUN)</li> </ul> </li> <li>f1: F.RUN/R.RUN stop method               <ul style="list-style-type: none"> <li>= 1: Coasts to stop</li> <li>= 2: Ramp down to stop</li> </ul> </li> <li>f2: JOG Stop method               <ul style="list-style-type: none"> <li>= 1: coast to stop</li> <li>= 2: Ramp down to stop</li> </ul> </li> <li>f3: Autostart (To F.RUN/R.RUN)               <ul style="list-style-type: none"> <li>= 1: off</li> <li>= 2: on without pick-up</li> <li>= 3: on with pick-up (re-start after a momentary power loss)</li> </ul> </li> </ul>
1	Emergency Stop (EMS) method	11.	11.	32.		<ul style="list-style-type: none"> <li>f0: Input logic               <ul style="list-style-type: none"> <li>= 1: Close to stop</li> <li>= 2: Open to stop</li> </ul> </li> <li>f1: Stop method               <ul style="list-style-type: none"> <li>= 1: Coast to stop without a fault output</li> <li>= 2: Coast to stop with a fault output</li> <li>= 3: Ramp down to stop</li> </ul> </li> </ul>
2	Control source switchover method	11.	11.	22.		<ul style="list-style-type: none"> <li>f0: J1 Selector (Use of auxiliary remote sequence commands in local mode (LCL))               <ul style="list-style-type: none"> <li>= 1: Off(disables auxiliary remote sequence commands)</li> <li>= 2: On(enables auxiliary remote sequence commands)</li> </ul> </li> <li>f1: J2 Selector (Source of auxiliary remote sequence commands with COP command is on)               <ul style="list-style-type: none"> <li>= 1: Off (terminal block input)</li> <li>= 2: On (CPU input)</li> </ul> </li> </ul>
<b>B02 - Start/Stop Frequency</b>						
0	Start Frequency	1.0	0.1	60.0	Hz	
1	Stop Frequency (DC brake start)	1.0	0.1	60.0		

## 6. Control Functions and Parameter Settings

No.	Parameter	Default	Min.	Max.	Unit	Function																																														
<b>B03 - Programmable Input Configuration 1 (Operating Commands)</b>																																																				
0	R.RUN	1.	0.	16.		<table border="1" style="width: 100%; border-collapse: collapse;"> <thead> <tr> <th style="width: 15%;">Value</th> <th style="width: 85%;">Input terminal</th> </tr> </thead> <tbody> <tr> <td>0</td> <td>OFF state</td> </tr> <tr> <td>1</td> <td>PSI1</td> </tr> <tr> <td>2</td> <td>PSI2</td> </tr> <tr> <td>3</td> <td>PSI3</td> </tr> <tr> <td>4</td> <td>PSI4</td> </tr> <tr> <td>5</td> <td>PSI5</td> </tr> <tr> <td>6</td> <td>PSI6</td> <td>Optional</td> </tr> <tr> <td>7</td> <td>PSI7</td> <td>Optional</td> </tr> <tr> <td>8</td> <td>PSI8</td> <td>Optional</td> </tr> <tr> <td>9</td> <td>PSI9</td> <td>Optional</td> </tr> <tr> <td>10</td> <td>(PL0)</td> <td rowspan="3">Program outputs (For future use)</td> </tr> <tr> <td>11</td> <td>(PL1)</td> </tr> <tr> <td>12</td> <td>(PL2)</td> </tr> <tr> <td>13</td> <td>(PL3)</td> <td></td> </tr> <tr> <td>14</td> <td>EMS</td> <td></td> </tr> <tr> <td>15</td> <td>FRUN</td> <td></td> </tr> <tr> <td>16</td> <td>ON state</td> <td></td> </tr> </tbody> </table>	Value	Input terminal	0	OFF state	1	PSI1	2	PSI2	3	PSI3	4	PSI4	5	PSI5	6	PSI6	Optional	7	PSI7	Optional	8	PSI8	Optional	9	PSI9	Optional	10	(PL0)	Program outputs (For future use)	11	(PL1)	12	(PL2)	13	(PL3)		14	EMS		15	FRUN		16	ON state		
Value	Input terminal																																																			
0	OFF state																																																			
1	PSI1																																																			
2	PSI2																																																			
3	PSI3																																																			
4	PSI4																																																			
5	PSI5																																																			
6	PSI6	Optional																																																		
7	PSI7	Optional																																																		
8	PSI8	Optional																																																		
9	PSI9	Optional																																																		
10	(PL0)	Program outputs (For future use)																																																		
11	(PL1)																																																			
12	(PL2)																																																			
13	(PL3)																																																			
14	EMS																																																			
15	FRUN																																																			
16	ON state																																																			
1	F.JOG	2.																																																		
2	R.JOG	3.																																																		
3	HOLD	0.																																																		
4	BRAKE	0.																																																		
5	PICK	0.																																																		
6	COP	0.																																																		
7	CSEL	0.																																																		
8	IPASS	0.																																																		
<b>B04 - Programmable Input Configuration 2 (Select Commands)</b>																																																				
0	VFS	16.	0.	16.																																																
1	IFS	0.																																																		
2	PROG	0.																																																		
3	CFS	0.																																																		
4	S0	0.																																																		
5	S1	0.																																																		
6	S2	0.																																																		
7	FUP	0.																																																		
8	FDW	0.																																																		
9	FUP/FDW Step	0.10	2.00	0.01	Hz																																															
<b>B05 - Meter Output Gain &amp; Scale Multiplier</b>																																																				
0	Output gain for FM (1)	1.00	0.20	2.00		10V at Fmax when this is set to 1.00. 5V at the rated current when this is set to 1.00. (Max. 11V)																																														
1	Output gain for AM (1)	1.00	0.20	2.00																																																
2	Arbitrary Scale (AS) Display Coefficient	30.00	0.01	100.00																																																
<b>B06 - Parameter Protection/Operation Locks</b>																																																				
-0	Parameter Protection/Operation Locks	1111.	1111	1239		<div style="display: flex; align-items: flex-start;"> <div style="margin-right: 20px;"> <p>Parameter Protection: O: Unprotected (changeable) X: Protected (unchangeable)</p> </div> <table border="1" style="border-collapse: collapse; text-align: center;"> <thead> <tr> <th rowspan="2">f0 Value</th> <th rowspan="2">Block A</th> <th colspan="4">Block B</th> </tr> <tr> <th>Basic</th> <th>Extn.</th> <th>S/W</th> <th>H/W</th> </tr> </thead> <tbody> <tr> <td>1</td> <td>○</td> <td>○</td> <td>○</td> <td>○</td> <td>○</td> </tr> <tr> <td>2</td> <td>X</td> <td>X</td> <td>X</td> <td>X</td> <td>X</td> </tr> <tr> <td>3</td> <td>○</td> <td>X</td> <td>X</td> <td>X</td> <td>X</td> </tr> <tr> <td>4</td> <td>○</td> <td>X</td> <td>○</td> <td>X</td> <td>X</td> </tr> <tr> <td>5</td> <td>○</td> <td>X</td> <td>○</td> <td>○</td> <td>X</td> </tr> <tr> <td>6-8</td> <td>X</td> <td>X</td> <td>X</td> <td>X</td> <td>X</td> </tr> </tbody> </table> </div> <div style="margin-top: 20px;"> <p>Operation panel: f1= 1: Enable control from operating panel 2: Disable control from Operation Panel (except for STOP key which, if pressed for 2 seconds, will stop the drive) 3: Only STOP key is available</p> <p>LCL switchover: f2= 1: Disables switchover while the drive is running 2: Enables switchover while the drive is running</p> <p>(Not in use)</p> </div>	f0 Value	Block A	Block B				Basic	Extn.	S/W	H/W	1	○	○	○	○	○	2	X	X	X	X	X	3	○	X	X	X	X	4	○	X	○	X	X	5	○	X	○	○	X	6-8	X	X	X	X	X
f0 Value	Block A	Block B																																																		
		Basic	Extn.	S/W	H/W																																															
1	○	○	○	○	○																																															
2	X	X	X	X	X																																															
3	○	X	X	X	X																																															
4	○	X	○	X	X																																															
5	○	X	○	○	X																																															
6-8	X	X	X	X	X																																															

## 6. Control Functions and Parameter Settings

TABLE 6.3 (3)

No.	Parameter	Default	Min.	Max.	Unit	Function
<b>B06 - Parameter Protection/Operation Locks</b>						
-1	Reverse Lock	11.	11	22		R.RUN 1: Enables reverse run 2: Disables reverse run R.JOG 1: Enables reverse jog 2: Disables reverse jog
-2	Fault History Buffer Clear	0.	0	9999		1: Clear all records on Fault History Buffer. Any other value will be ignored and the records will remain unchanged.
-3	Default Value Load (2)	0.	0	9999		9: Reset all the parameters to default values. 10: Reset all the Block-A Parameters to default values. 11: Reset Block-B Parameters to default values. (Basic Function Parameters only) 12: Reset Block-B Parameters to default values. (Extended Function Parameters only) 13: Reset Block-B Parameters to default values. (Software Option Parameters only) 14: Reset Block-B Parameters to default values. (Hardware Option Parameters only)
<b>B07 - Custom Parameter Register</b>						
0	Custom - 0	00.0	00.0	99.9		Set (register) for each parameter No. to be displayed and changed as an A04-0~7 custom parameter.
1	- 1					
2	- 2					
3	- 3					
4	- 4					
5	- 5					
6	- 6					
7	- 7					
<b>B08 - Operation Panel Initial Mode</b>						
0	Initial mode	11.	11.	32		f0: Local/remote selection = 1: Local (LCL) = 2: Remote (RMT) f1: Run command status = 1: Stop = 2: Forward run = 3: Reverse run } Set only when B01-0/f3=2,3
1	Operation panel monitor parameter	0.0	0.0	9.9		Set the monitor parameter No.
2	LCD-OPU (option) monitor parameter	0.0	0.0	9.9		
						f0: Parameter Number f1: Block Number