

VLT® 5000/VLT® 5000 FLUX



Operating Instructions

Synchronizing Controller



Table of contents

<i>Safety regulations</i>	3
<i>Introduction</i>	4
Function description	4
Speed synchronization	4
Position synchronization (angle synchronization)	4
Marker synchronization	4
Mechanical brake control	5
Tips and tricks for synchronization tasks	5
Hardware	7
VLT control card terminals	7
Technical data	7
Option card terminals	7
Supply voltages	8
Encoder monitor	9
Option card layout	10
Technical Data	12
Examples of encoder interface connections	14
Description of terminals	15
Description of Field bus interface	20
Data layout	20
Description of parameters	22
Initializing the parameters	35
<i>Speed synchronization</i>	36
Function diagrams for speed synchronization	37
SyncStart	37
Up/down factor	37
Hold function	39
Gear changing	39
Changing the gear ratio with an analogue value	40
Application example – Admixture	41
Description of terminals and terminal configuration	41
Setting the parameters	42
How to check the motor connection	43
How to test the incremental encoders	43
How to optimize the controller:	44
How to program synchronization	46
Operation and operating functions	47
<i>Position synchronization (angle synchronization)</i>	48
Function diagrams for position synchronization	49
SyncStart to a stationary master	49
SyncStart to a running master	49
Position displacement with a running master	50
Application example – Embossing patterns on mould	51
Description of terminals and terminal configuration	51
Setting the parameters	52
How to check the motor connection	53
Testing the incremental encoders	53
How to optimise the controller	53

How to program synchronization.....	55
Operation and operating functions.....	57
Marker synchronizing	58
Function diagrams for marker synchronization	59
SyncStart to a running master after Power ON.....	59
Marker correction during operation.....	59
Application example - Packaging	60
Terminals and terminal configuration.....	61
Setting the parameters.....	62
How to check the motor connection.....	63
How to test the incremental encoders.....	63
How to optimise the controller.....	64
How to program synchronization.....	66
Operation and operating functions.....	68
Appendix	69
Messages and error reference	69
Table of error messages.....	69
Parameter overview	71
Glossary of key terms	79
List of illustrations	83
Index	84

Synchronizing Controller for VLT 5000 and VLT 5000Flux

Software Version 2.0X

Software Version number: See Parameter 779



The voltage of the frequency converter is dangerous whenever the equipment is connected to mains. Incorrect installation of the motor or the frequency converter may cause damage to the equipment, serious personal injury or death. Consequently, the instructions in this manual, as well as national and local rules and safety regulations, must be complied with.

Safety regulations

1. The VLT frequency converter must be disconnected from mains if repair work is to be carried out. Check that the mains supply has been disconnected and that the necessary time has passed before removing motor and mains plugs.
2. The [STOP/RESET] key on the control panel of the VLT frequency converter does not disconnect the equipment from mains and is thus not to be used as a safety switch.
3. Correct protective earthing of the equipment must be established, the user must be protected against supply voltage, and the motor must be protected against overload in accordance with applicable national and local regulations.
4. The earth leakage currents are higher than 3.5 mA.
5. Protection against motor overload is not included in the factory setting. If this function is desired, set parameter 128 to data value *ETR trip* or data value *ETR warning*.
Note: The function is initialised at 1.16 x rated motor current and rated motor frequency (see page 92).
For the North American market: The ETR functions provide class 20 motor overload protection in accordance with NEC.
6. Do not remove the plugs for the motor and mains supply while the VLT frequency converter is connected to mains. Check that the mains supply has been disconnected and that the necessary time has passed before removing motor and mains plugs.
7. Please note that the VLT frequency converter has more voltage inputs than L1, L2 and L3, when load sharing (linking of DC intermediate circuit) and external 24 V DC have been installed. Check that all voltage inputs have been disconnected and that the necessary time has passed before repair work is commenced.

Warning against unintended start

1. The motor can be brought to a stop by means of digital commands, bus commands, references or a local stop, while the frequency converter is connected to mains.
If personal safety considerations make it necessary to ensure that no unintended start occurs, these stop functions are not sufficient.
2. While parameters are being changed, the motor may start. Consequently, the stop key [STOP/RESET] must always be activated, following which data can be modified.
3. A motor that has been stopped may start if faults occur in the electronics of the VLT frequency converter, or if a temporary overload or a fault in the supply mains or the motor connection ceases.



Warning:

Touching the electrical parts may be fatal - even after the equipment has been disconnected from mains. Also make sure that other voltage inputs have been disconnected, such as external 24 V DC, load sharing (linkage of DC intermediate circuit), as well as the motor connection for kinetic back-up.

Using VLT 5001-5006 220 and 500 V units: wait at least 4 minutes
 Using VLT 5008-5500 220 and 500 V units: wait at least 15 minutes
 Using VLT 5001-5005 550-600 V units: wait at least 4 minutes
 Using VLT 5006-5022 550-600 V units: wait at least 15 minutes
 Using VLT 5027-5250 550-600 V units: wait at least 30 minutes

Introduction

The Synchronizing Controller is an application option for VLT5000 and VLT5000Flux.

The application option consists of two parts

- Synchronizing controller part
- Test Run part

Function description

The Synchronizing controller can be used in any application where a drive is to operate synchronously with a master drive. The synchronizing controller acts as an electronic shaft. The gear ratio is freely selectable and can also be changed during operation. The speed or the position is automatically and accurately controlled based on encoder feedback signals from both the master drive and the slave drives.

For synchronous operation of two or more drives you can use

- Speed synchronization
- Position synchronization or
- Marker synchronization

Speed synchronization

This is the simplest type of synchronization. It can be used to compensate for speed differences, where it is not necessary to compensate for position errors.

The speed synchronization between master and slave is done at maximum acceleration. To obtain optimum control the slave drive should therefore be set for a quicker acceleration speed than that of the master drive.

Position synchronization (angle synchronization)

This is the electronic shaft ensuring a constant angle position ratio between master and slave drives. In case of a position deviation the slave drive is automatically accelerated to a speed level that is sufficient for regaining its position to the master drive (I-control like).

Marker synchronization

Marker synchronization is an *extended* position control. Apart from ensuring a constant angle position between master and slave drives, marker synchronization provides the option of using either an additional sensor or the zero track of the incremental encoder to compensate for any deviations between master and slave that may occur during operation. Using marker synchronization the slave is position synchronized until the markers is reached and then the control compensates for the position difference between master marker and slave marker. This type of control is used where precision cannot be achieved by using a motor mounted encoder. That could be because of gearbox slack or other disturbance like belt elongation etc. that are not directly measurable. Similarly, with marker synchronization, the slave drive does not need to be brought into the start position of the master drive at initial start-up, as this is affected automatically by marker correction.

Mechanical brake control

The Synchronizing controller has a 24V dc digital output (Output 4) to control an electromechanical brake; this is very useful in applications when a motor (shaft) must be kept in the same position for a longer time. This is usually the case in hoisting applications. The brake output will be active (low) in case of an error and when synchronization is stopped, that means whenever motor control is switched off. The brake signal can be delayed when switched on and off in two individual parameters (P. 755 “brake on delay” and P. 756 “brake off delay”).

Please note that the brake output is kept low in VLT mode (input 8 = high). That means the brake must be opened for example by means of the VLT mechanical brake function in set-up 2.

Tips and tricks for synchronization tasks

When configuring the drives to be synchronized please keep in mind that the ratios should be of integer size. When using gear it is also important to know the number of teeth of the various gear stages (ask the gear manufacturer) as gears are normally set up with infinite gear ratios.

When calculating the ratios between master and slave you must either use the figure PI for both of them or not use PI at all.

Example:

A master drive with a 4-pole motor and an incremental encoder of 1024 increments/revolution works on a 2-stage gear. i is specified to be 30.33. At the gear output, a belt ratio of 40:20 is placed, driving a conveyor belt on the drive side with a diameter of 102mm.

Via a 3-stage gear (i is specified to be 46,54) the slave drive is connected to an 8-toothed chain conveyor with a tooth pitch of 200mm.

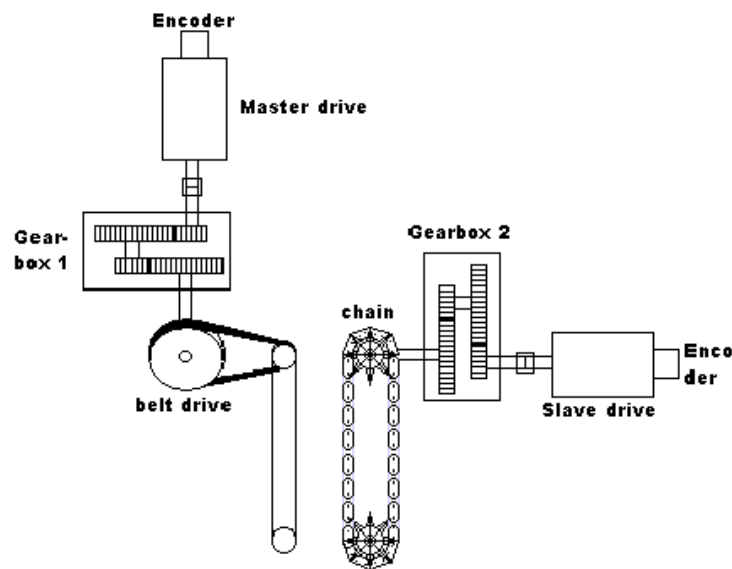

Figure 1: Calculation example

Calculation with insufficient numerical values

The master/slave gear ratio (numerator to denominator) is now calculated as follows:

$$\text{Master side} = \text{increments} * i1 * i2 * \text{power take off} = 1024\text{incr} * 30.33 * \frac{20}{40} * \frac{1}{102\text{mm} * \pi} = 48,460995$$

$$\text{Slave side} = \text{increments} * i1 * \text{power take off} = 1024\text{incr} * 46.54 * \frac{1}{8 * 200\text{mm}} = 29,7856$$

This gives a ratio of $\frac{48,460995}{29,7856}$

That gives a numerical value of 48,460995 for the numerator and 29,7856 for the denominator. **Note:** It is only possible to enter integer values. The most serious error: The master expression contains the value Pi, an infinite number sequence. Even with small numerical values for master and slave, the effect would always be that the drives drifted apart, as the Numerator: Denominator expression can never be an integer.

Another error arises from the gear ratios given, as the master drive was specified with a value of $i = 30.33$. The correct ratio is easily found by recalculating the individual numbers of teeth. The gear is a 2-stage gear; the first stage is formed from two pinions, 126 to 27, and the second stage from two pinions, 117 to 18.

The ratio is calculated as: $\frac{126 * 117}{27 * 18} = 30\frac{1}{3}$ The specified value of 30.33 thus deviates by 0.1%.

This may appear small; if this error is related to the encoder resolution, however, it will be seen that even this error is serious.

From the example it can be seen that it is important to maintain the exact values of the gear stages and to ensure that the data include Pi either for both drives or for none of them.

Example with corrected numerical values:

Master side: Gear 1st stage 126/27 2nd stage 117/18; belt ratio 40/20; drive shaft 100 mm

Slave side: Gear 1st stage 97/10, 2nd stage 43/11, 3rd stage 27/22; effective diameter of the sprocket wheel 510mm

$$\text{Master side: } \frac{1024\text{Incr.} * 126 * 117 * 20}{27 * 18 * 40 * 102 * \pi}$$

$$\text{Slave side: } \frac{1024\text{Incr.} * 97 * 43 * 27}{10 * 11 * 22 * 510 * \pi}$$

To remove Pi from the equations, substitute both equations into the combined formula:

$$\frac{\text{Masterside}}{\text{Slaveside}} =$$

$$\frac{1024\text{Incr.} * 126 * 117 * 20}{27 * 18 * 40 * 102 * \pi} \div \frac{1024\text{Incr.} * 97 * 43 * 27}{10 * 11 * 22 * 510 * \pi}$$

$$\frac{1024\text{Incr.} * 126 * 117 * 20 * 510 * \pi * 10 * 11 * 22}{27 * 18 * 40 * 1024\text{Incr.} * 97 * 43 * 27 * 102 * \pi}$$

Reduce by Pi and 1024 incr.:

$$\frac{126 * 117 * 20 * 510 * 10 * 11 * 22}{27 * 18 * 40 * 97 * 43 * 27 * 102}$$

Reduce further:

$$\frac{7 * 5 * 5 * 11 * 22 * 117}{27 * 97 * 43 * 27}$$

This gives a ratio of $\frac{4954950}{3040659}$.

This is an absolute value, as it contains no infinite number sequences and no rounded values.

Hardware

VLT control card terminals

The terminals on the control card are allocated for synchronizing controller functions the following parameter settings should therefore not be changed in synchronizing mode (set-up 1):

Digital inputs 16, 17, 18, 19, 27, 29, 32 and 33

Parameters 300–303 and 305–307 are set to "No operation" (default setting), then the inputs are ignored by the control card but they can still be used as inputs to the synchronizing controller.

Analogue inputs 53, 54 and 60

Parameters 308, 311 and 314 are set to "No operation", then the inputs are ignored by the control card but they can still be used as inputs to the synchronizing controller.

Digital/analogue outputs 42 and 45

Parameters 319 and 321 are set to:

OPTION 0 ... 20 mA [91] analogue output
(default setting)

Technical data

Technical data on the control card terminals can be found in the VLT 5000 design guide.

Option card terminals

There are two encoder interfaces, which are covering the following functions:

- Feedback encoder input

Terminal	A1	$\overline{A1}$	B1	$\overline{B1}$	Z1	$\overline{Z1}$
Incremental input	A in	\overline{A} in	B in	\overline{B} in	Z in	\overline{Z} in
Absolute input	Clk out	\overline{Clk} out	Data in	\overline{Data} in	Not used	Not used
Virtual master	A out	\overline{A} out	B out	\overline{B} out	Z out	\overline{Z} out

Fig. 1

Terminal	A2	$\overline{A2}$	B2	$\overline{B1}$	Z2	$\overline{Z2}$
Incremental input	A in	\overline{A} in	B in	\overline{B} in	Z in	\overline{Z} in
Absolute input	Clk out	\overline{Clk} out	Data in	\overline{Data} in	Not used	Not used

Fig. 2

- Master encoder input / virtual master output

There are 8 digital inputs, 8 digital output and terminals for 5 V and 24 V supply. The functions and technical data of the terminals are described in the following.

Terminal description

There are 4 terminal blocks, 2 with 10 poles and 2 with 8 poles. (See figure below)

MK3A Digital Inputs

I1	I2	I3	I4	I5	I6	I7	I8	24V	COM

MK3B Master / Virtual Master

5V	COM	A1	A1	B1	B1	Z1	Z1

MK3C Digital Outputs

O1	O2	O3	O4	O5	O6	O7	O8	24V	COM

MK3D Feedback

5V	COM	A2	A2	B2	B2	Z2	Z2

Supply voltages

The option card is supplied by the internal 24 V DC supply of VLT 5000, but as the available power is limited it can be necessary to use an external 24 V DC supply.

The 24 V DC supply of VLT 5000 can supply a total of 420 mA including the load on the control card (terminal 12, 13 and output 42 and 45).

The 5 V output on the option card is generated from the 24 V supply. The maximum power on the 5 V side is $5\text{ V} * 280\text{ mA} = 1.4\text{ W}$, this corresponds to app. 60 mA on the 24 V side.

When an external 24 V DC voltage source is used the internal 24 V supply from the control card must be disconnected, this is done by opening switch 1.1 and 1.2

Each digital input on the option card takes 8 mA. Each digital output on the option card can supply up to 0.7 A (external 24V-supply) depending on the load. The load from the 24 V supply (internal or external) can be calculated as follows:

- 8 mA * number of digital inputs
- +
- Load on digital outputs (mk3 C, O1 – O8)
- +
- load on 5 V supply (mk3 B/D, 5 V/com)
- +
- Load on control card (24 V supply, terminal 12/13 and outputs, terminal 42/45)

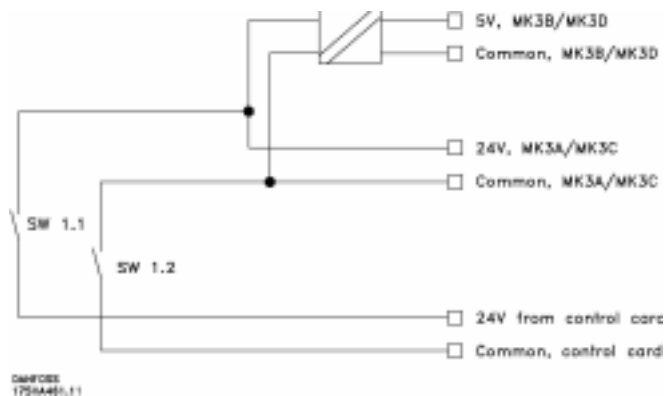

Encoder monitor

Both encoder interfaces are equipped with a monitoring circuit that can detect open circuit as well as short circuit of each encoder channel. Each encoder channel has a LED showing the status: Green light means ok, no light means fault. Zero channel monitoring can be switched off by means of switch 1.4, this is necessary when using incremental encoders without Zero channel or absolute encoders. Switch 1.4 disables monitoring of both master and slave Zero channel. If disabling of only one of the two Zero channels is required (e.g. when using incremental master encoder and absolute slave encoder) the unused Zero channel input must be connected to 5V/common as shown below.

An encoder fault will only result in an "Option error" 92 if encoder monitoring is activated via parameter 713 (master) and 711 (slave).

Note: Monitoring of the master encoder is disabled when switch 1.3 is "OFF".

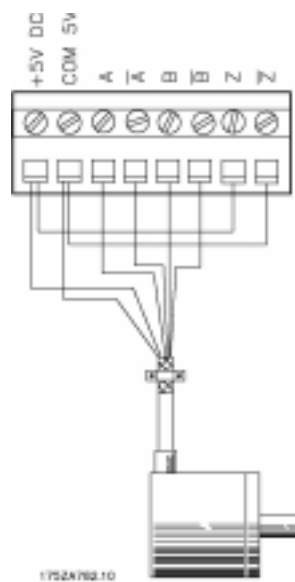

Option card layout

Option card layout showing the position of connectors and dip switch.

Encoder monitor master, channel A, B and Z:
LED off = Short or open circuit

175ZA783.10

Encoder monitor slave, channel A, B and Z:
LED off = Short or open circuit
LED green = Ok.

5V monitor:
LED off = no 5V
D Green = 5V ok.

CPU monitor:
LED must flash at 1 Hz to indicate a running CPU system

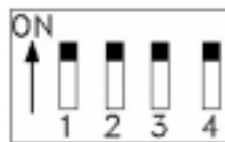
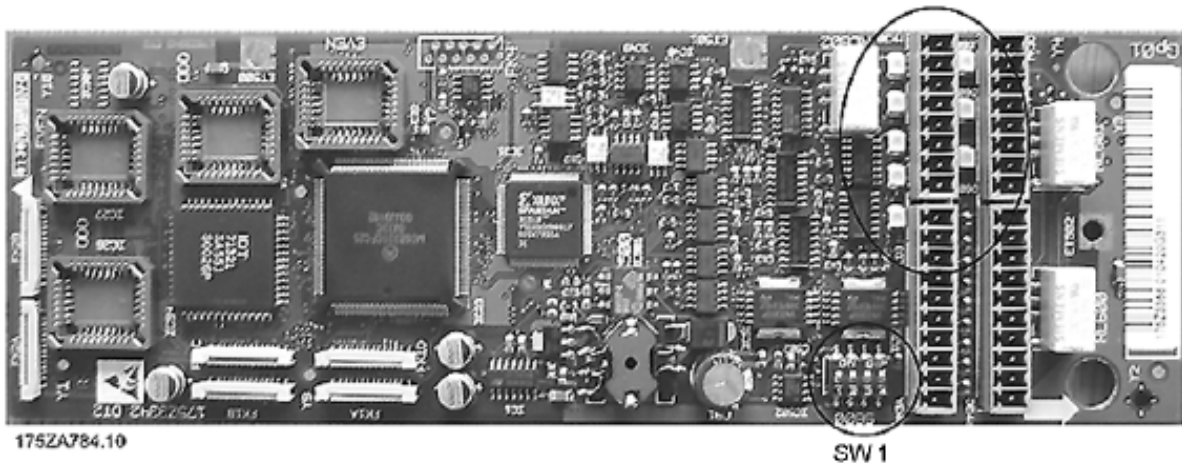

DANFOSS
175ZA068.10

- SW 1.1: Connect(ON)/disconnect(OFF) 24 V from control card (see description of supply voltages).
- SW 1.2: Connect(ON)/disconnect(OFF) 24 V common from control card.
- SW 1.3: Connect(ON)/disconnect(OFF) termination resistor for master encoder (see description of virtual master function).
Note: When OFF the master encoder monitor is disabled.
- SW 1.4: Switch Z-channel encoder monitor ON/OFF for both master and slave.

Default setting of switch 1.1. - 1.4 is ON.

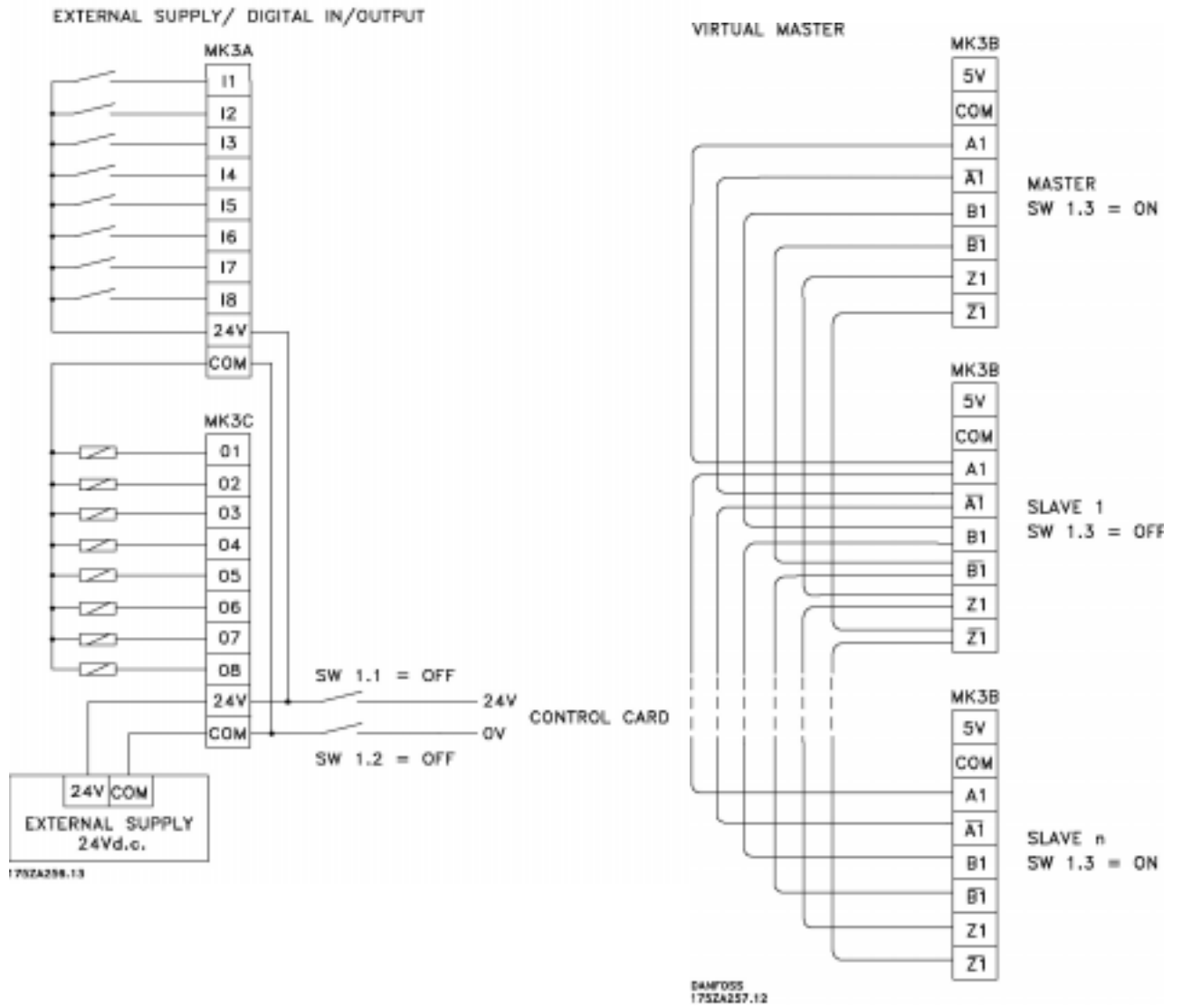

The terminating resistors on both end of the bus have to be switch on with dip switch SW 1.3.

Technical Data

Terminals:

Type.....	Plugs with screw connections
Maximum cable size	1.3 mm ² (AWG 16)

Digital inputs, MK3A:

Terminal designations	I1 – I8
Voltage level	0 – 24 V DC (PNP positive logic)
Voltage threshold logical “0”	5 V DC
Voltage threshold logical “1”	10 V DC
Maximum voltage	28 V DC
Input impedance	4 kΩ
Min. pulse duration (ON INT).....	1 msec

Galvanic isolation: All digital inputs are galvanically isolated by means of optocouplers, but with the same common as the digital outputs.

Digital outputs, MK3C:

Terminal designations	O1 – O8
Voltage level	0 – 24 V DC
Maximum load	0.7A (with external power supply)
Update rate.....	1 msec

Galvanic isolation: All digital outputs are galvanically isolated by means of optocouplers, but with the same common as the digital inputs.

External 24 V DC supply:

(see VLT 5000 manual)

Encoder input 1, MK3B (master):

Terminal designations	A1, $\overline{A1}$, B1, $\overline{B1}$, Z1, $\overline{Z1}$.
-----------------------------	---

Incremental:

Signal level	5 V differential
Signal type	Linedriver, RS 422
Input impedance	120 Ω (Dip switch 1.3 = ON)
.....	> 24 kΩ (Dip switch 1.3 = OFF)
Maximum frequency	220 kHz (at 50 % duty cycle)
Phase displacement between A and B.....	90° ±30°

Absolute:

Signal level	5 V differential
Signal type	SSI
Data coding	Gray code
Data length	25 bit
Parity.....	none
Clock frequency.....	105 or 260 kHz
Protocol	Gray
Maximum positions per revolution.....	8192
Maximum number of revolutions	4096

Encoder input 2, MK3D (slave):

Terminal designations	A2, $\overline{A2}$, B2, $\overline{B2}$, Z2, $\overline{Z2}$
<i>Incremental:</i>	
Signal level	5 V differential
Signal type	Linedriver, RS422
Input impedance	120 Ω
Maximum frequency	220 kHz (at 50 % duty cycle)
Phase displacement between A and B	90° \pm 30°
<i>Absolute:</i>	
Signal level	5 V differential
Signal type	SSI
Protocol	Gray code
Data length	25 bit
Parity	none
Clock frequency	105 or 260 kHz
Maximum positions per revolution	8192
Maximum number of revolutions	4096

Encoder cable:

Cable type... Twisted pair and screened. **Note:** Please observe the prescriptions of the encoder supplier

Cable length..... Observe the prescriptions of the encoder supplier.

Absolute encoder is tested ok up to 150 meter cable at 105 kHz clock and 100 m at 260 kHz clock.
*(Tested with TR electronic encoder type CE-65 M 8192*4096 and appropriate cable prescribed by TR electronic.)*

Maximum allowed time delay between clock and data signal measured at the controller terminals.....

..... 105 kHz clock = 9 μ sec

..... 260 kHz clock = 3.5 μ sec

Encoder output, MK3B:

Terminal designations	A1, $\overline{A1}$, B1, $\overline{B1}$, Z1, $\overline{Z1}$
Signal type	Linedriver, RS485
Maximum frequency	150 kHz
Minimum frequency	150 Hz
Maximum number of slaves	31 (more when using repeaters)
Maximum cable length.....	400 m

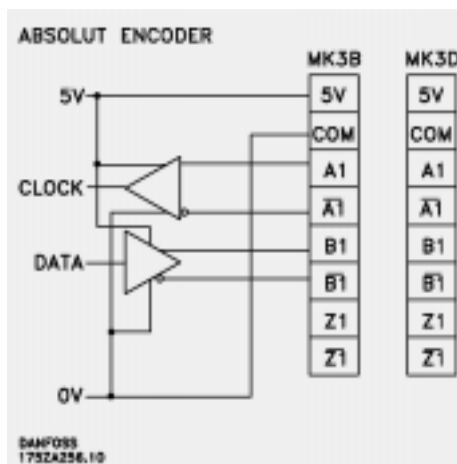
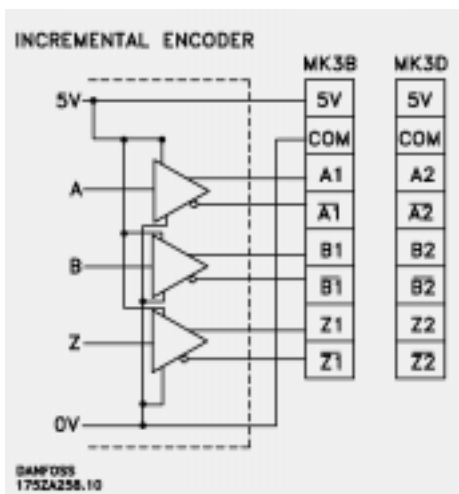

Examples of encoder interface connections

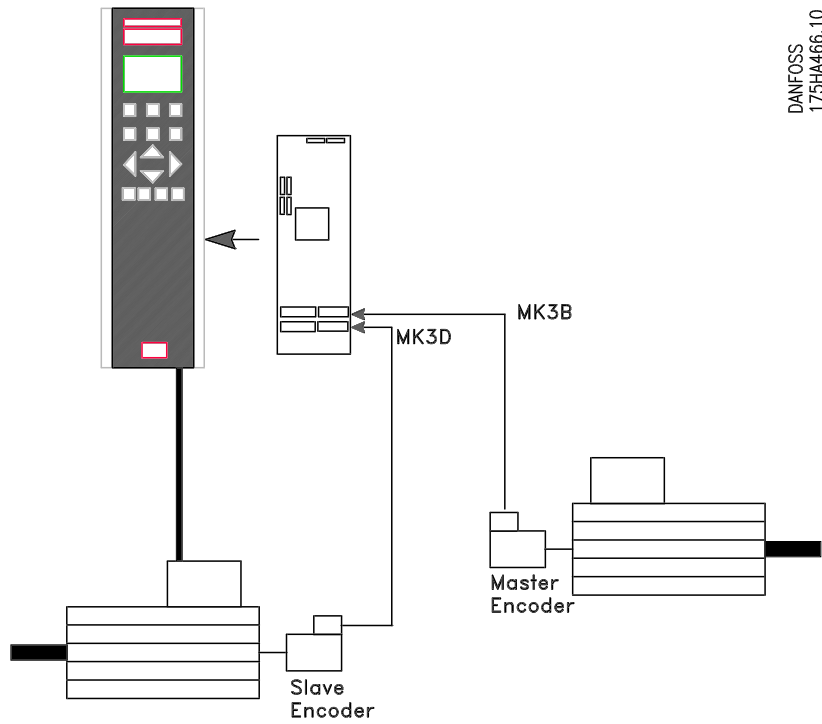

Figure 6: Master-Slave connection

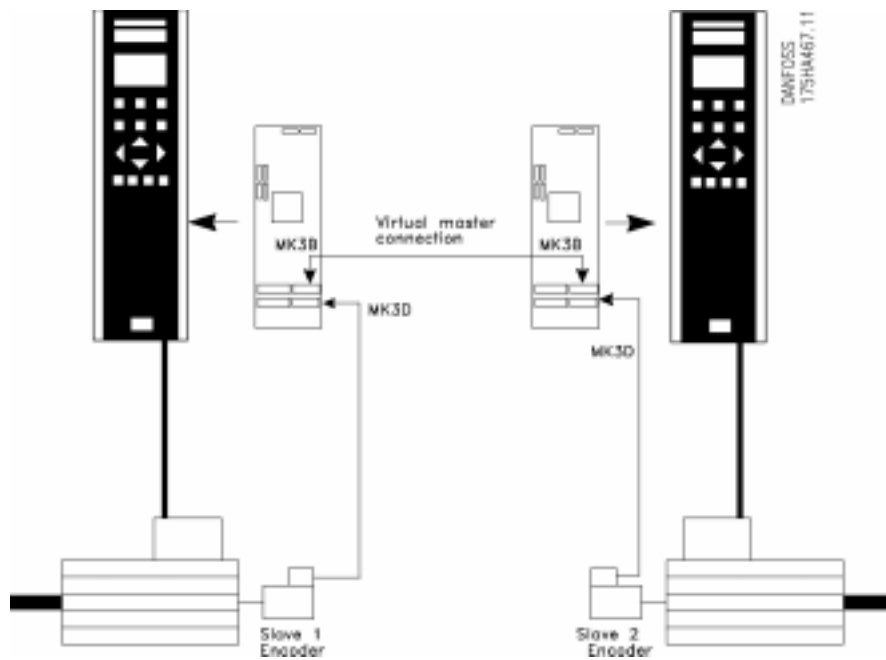

Figure 7: Virtual Master-Slave connection

Description of terminals

I/O #	Designation	Description
12	24V DC	24V power supply for switches etc. maximum load: see page 8
13	24V DC	24V power supply for switches etc. maximum load: see page 8
16	Gear ratio 2 ¹	Synchronous operation; Program 2: Gear ratio most significant bit
17	Gear ratio 2 ⁰	Synchronous operation; Program 2: Gear ratio least significant bit
18	Not used	
19	Home run	Synchronous operation; Program 2: Starts the homing.
20	GND	Ground for 24V, normally bridged with Terminal 39, but this can be set to "OFF" by means of Switch SW4 on the control card.
27	Reset/Enable	Error reset on rising edge. To enable operation, this input must be switched to "1". "0" = motor coast.
29	Hold	Synchronous operation; Program 2: The drive is held at a programmable, or the present speed. Synchronous control is not activated.
32	Test run reverse Speed/Pos –	Test run; Program 1: Test run reverse at the speed defined in Parameter 725 Synchronous operation; Program 2: In velocity synchronous mode (P. 725 = 0, 1, 6 or 7) the gear ratio and thus the velocity of the slave can be changed by the value specified in parameter 744. In position synchronous and marker synchronous operation (P. 725 = 1, 2, 4 or 5), the position offset of the slave can be changed by the value specified in Parameter 744.
33	Test run forward Speed/Pos +	Test run; Program 1: Test run forward at the speed defined in Parameter 725 Synchronous operation; Program 2: In velocity synchronous mode (P. 725 = 0, 1, 6 or 7) the gear ratio and thus the velocity of the slave can be changed by the value specified in parameter 744. In position synchronous and marker synchronous operation (Parameter 725 = 1, 2, 4 or 5), the position offset of the slave can be changed by the value specified in Parameter 744.

01	COM; 240V AC/2A	Relay output:
02	NO	Function can be configured by means of Parameter 323.
03	NC	
04	COM; 50V AC/1A; 75V DC/1A	Relay output:
05	NO	Function can be configured by means of Parameter 326.
39	GND	Ground for analogue inputs/outputs, normally bridged with Terminal 20, but this can be set to "OFF" by means of Switch SW 4 on the control card.
42	Slave velocity	The output value is scaled to maximum slave velocity (parameter 716); the signal type can be selected in parameter 319.
45	Master velocity	The output value is scaled to maximum slave velocity (parameter 716) multiplied by the gear ratio; the signal type can be selected in parameter 321.
50	10V DC 17mA	Power supply for reference value potentiometer
53	± 10V-In	Serves as reference input for the virtual master if "0" is selected in Parameter 748.
54	± 10V-In	Synchronous operation; Program 2: Serves as numerator for the gear ratio if "6" or "7" is selected in parameter 725.
60	± 20mA-In	Serves as reference input for the virtual master if "1" is selected in Parameter 748.

Standard RS485-Interface

61	Ground RS485	Not used
68	RS485-P	Not used
69	RS485-N	Not used

Option card MK3A

1	I1 - Sync-Start	<p>Synchronous operation; Program 2:</p> <p>Start and stop of synchronization. Input 1 must be toggled if synchronization was interrupted by an error or by input 27 (motor coast). Behaviour at stop can be selected via parameter 725.</p>
2	I2 - Take over gear ratio	<p>Synchronous operation; Program 2:</p> <p>Activates the gear ratio selected at Terminals 16 and 17.</p>
3	I3 - Start/Stop virtual master	<p>Test run; Program 1:</p> <p>Start test run with virtual master.</p> <p>Synchronous operation; Program 2: The virtual master is accelerated up to the set pulse frequency, or stopped, with the set ramp time.</p>
4	I4 - Saving the settings	<p>“1” = All 7xx parameters are saved. Input 4 must be reset to “0” to end the save procedure. Parameter 710 will be 1 and output 5 will be high while saving. Note: saving is only possible if all inputs, except input 27, are low. Input 27 must be high.</p>
5	I5 - Master marker input	<p>When using external marker signal for the master drive it must be connected to this input.</p>
6	I6 - Slave marker input	<p>When using external marker signal for the slave drive it must be connected to this input.</p>
7	<p>I7 - Measuring of the master marker interval</p> <p>Home switch</p>	<p>Test run; Program 1:</p> <p>Measuring of the master marker interval is started.</p> <p>Synchronous operation; Program 2:</p> <p>If a home position is to be attained, the home switch must be connected here. The signal must show a rising edge</p>
8	<p>I8 - measuring of the slave marker interval</p> <p>I8 - VLT mode selection</p>	<p>Test run; Program 1:</p> <p>Measurement of the slave marker interval is started.</p> <p>Synchronous operation; Program 2: Switches the VLT to normal frequency converter operation. The settings for this operating mode are to be made in Parameter set 2. Refer to the VLT 5000 Product Manual.</p>
9	24V DC	
10	COM	

Option card MK3B (master encoder)

1	5V DC	Encoder supply	
2	COM	Encoder supply	
		<i>Incremental encoder</i>	<i>Absolute encoder</i>
3	A1	A-track	Clock out
4	/A1	A-track inverted	Clock out inverted
5	B1	B-track	Data in
6	/B1	B-track inverted	Data in inverted
7	Z1	Zero-track	Not used
8	/Z1	Zero-track inverted	Not used

Option card MK3C

1	O1 - READY	<i>Synchronous operation; Program 2:</i> Ready, i.e. for the number of marker signals that were specified in Parameter 735, the slave drive has run within the tolerance (Accuracy).
2	O2 - FAULT	<i>Synchronous operation; Program 2:</i> Fault, i.e. for the number of marker signals that were specified in Parameter 734, the slave drive has run outside the tolerance (Accuracy).
3	O3 - ACCURACY	<i>Synchronous operation; Program 2:</i> The drive runs within the tolerance specified in Parameter 733.
4	O4 - Brake control	This output can be used to control a mechanical brake. "0" means that the brake must be closed (braking) "1" means that the brake must be open (not braking)
5	O5 - Saving	This output stays high while saving is in progress. The saving is initiated by Parameter 710, Input 4 or fieldbus bit 4.
6	O6 - Drive running	Signal "1" when the drive is running.
7	O7 - Home reached	<i>Synchronous operation; Program 2:</i> If the data value "1" or "2" was chosen in Parameter 729, this output shows "1" homing is completed.

8	O8 - Ready, no error	The Synchronizing controller is ready for operation.
9	24V DC	
10	COM	

Option card MK3D (slave encoder)

1	5V DC	Encoder supply	
2	COM	Encoder supply	
		<i>Incremental encoder</i>	<i>Absolute encoder</i>
3	A1	A-track	Clock out
4	/A1	A-track inverted	Clock out inverted
5	B1	B-track	Data in
6	/B1	B-track inverted	Data in inverted
7	Z1	Zero-track	Not used
8	/Z1	Zero-track inverted	Not used

Description of Field bus interface

NOTE: This section is only relevant if the VLT is equipped with a Field bus interface (option) as well as the Synchronizing controller.

The Synchronizing controller can be controlled via the digital/analogue inputs or via field bus. The control source can be selected individually for test-run and synchronizing in the parameters 753 (test-run) and 754 (synchronizing). There can only be one control source at a time meaning that the digital/analogue inputs are inactive when Field bus is selected as control source and visa versa. The only exception is input 27, which is always stop/enable also when Field bus is selected as control source. In synchronizing mode three signals are only available as digital inputs even when Field bus is selected as control source that is the marker signals for marker synchronization and the Home switch. This is because these signals are too time-critical for Field bus control.

Status signals are always available on the digital/analogue outputs but they are only available via Field bus when Field bus is selected as control source.

Data layout

Control and status signals are transferred via the so-called process data channel (PCD) of the various field bus interfaces. The telegram structure and the available number of data words depends on the Field bus used, please refer to the manual of the Field bus option in use for further details. The below example is based on the layout of a PROFIBUS telegram, the so-called PPO:

Example using PROFIBUS PPO type 5:

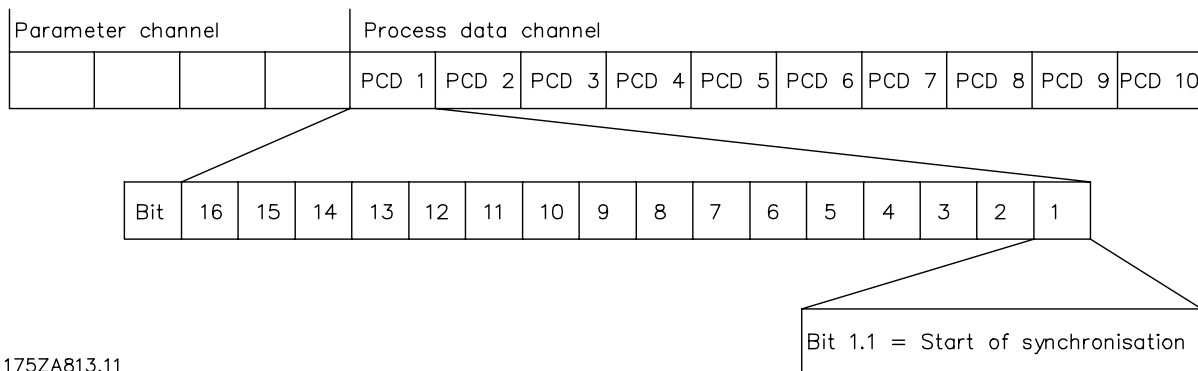

175ZA813.11

Field bus control signals:

Field bus [word.bit]	Test run	Synchronizing	Corresponding input
1.1	<i>Not used</i>	Start of synchronization	1
1.2	<i>Not used</i>	Take over gear ratio	2
1.3	Start/stop virtual master	Start/stop virtual master	3
1.4	Save settings	Save settings	4
1.5	<i>Not used</i>	VLT-mode	8
1.6	<i>Not used</i>	Gear-ratio select MSB	16
1.7	<i>Not used</i>	Gear-ratio select LSB	17
1.8	<i>Not used</i>	Start homing	19

1.9	Reset/enable	Reset/enable	27
1.10	<i>Not used</i>	Hold	29
1.11	<i>Not used</i>	Speed/position -	32
1.12	<i>Not used</i>	Speed/position +	33
1.13	Measuring master marker distance	<i>Not used</i>	7
1.14	Measuring slave marker distance	<i>Not used</i>	8
1.15	Test-run left	<i>Not used</i>	32
1.16	Test-run right	<i>Not used</i>	33
2	Virtual master reference*	Virtual master reference*	53/60

* Only when Parameter 748 = 3.

Field bus status signals:

Field bus [word.bit]	Test run	Synchronizing	Corresponding output / parameter
1.1	<i>Not used</i>	Ready	1
1.2	<i>Not used</i>	Fault	2
1.3	<i>Not used</i>	Accuracy	3
1.5	Saving	Saving	5
1.6	Running	Running	6
1.7	<i>Not used</i>	Home reached	7
1.8	Ready, no error	Ready, no error	8
2	Track error	Track error	P775/797
3	<i>Not used</i>	Synchronizing error	P797
4	<i>Not used</i>	Status of Synchronization	P778
5	Slave speed	Slave speed	P798
6	Master speed	Master speed	P799

Description of parameters

Parameter number	Description
701	Selection of the operation mode: "1" - test run; "2" - synchronization
702	P-portion of the Synchronizing controller. Setting: see Examples.
703	D-portion of the Synchronizing controller. Setting: see Examples.
704	I-portion of the Synchronizing controller. Setting: see Examples.
705	Limitation for I-portion. Setting: see Examples.
706	Band width for PID controller
707	Velocity feed forward. Setting: see Examples.
708	Acceleration feed forward. Setting: see Examples.
709	Velocity filter
710	Store data: Here you can save the selected data permanently in the EEPROM. 0 = no function, 1 = data are being saved. While saving continues, the digit value remains "1"; when saving is finished, the digit value automatically reverts to "0". Similarly, during saving, Output O5 "Saving" is set to "1". Saving is not possible during operation, but only in the disengaged, stopped state.
711	Slave encoder type: Setting range: 0 = Incremental encoder. 1 = Absolute encoder with 262kHz clock frequency, 2 = Absolute encoder with 105kHz clock frequency. 100 = as "0" but with hardware monitor active. 101 = as "1" but with hardware monitor active. 102 = as "2" but with hardware monitor active.
712	Slave encoder resolution in increments per rotation.
713	Master encoder type: Setting range: 0 = Incremental encoder. 1 = Absolute encoder with 262kHz clock frequency, 2 = Absolute encoder with 105kHz clock frequency. 100 = as "0" but with hardware monitor active. 101 = as "1" but with hardware monitor active. 102 = as "2" but with hardware monitor active.
714	Master encoder resolution in increments per rotation.

715 **Direction of rotation:**

- 1 = standard, position is counting positive when the drive is running forward.
- 1 = position is counting negative when the drive is running forward.
- 2 = as "1", but with opposite sign of the reference to the drive. This can be used as alternative to swapping two motor phases if direction of motor rotation is wrong.
- 2 = as "-1", but with opposite sign of the reference to the drive. This can be used as alternative to swapping two motor phases if direction of motor rotation is wrong.

716 **Maximum speed:** Enter here the maximum speed of the slave drive, measured at the slave encoder in revolutions per minute.

717 **Minimum ramp:** Enter here the minimum possible ramp in which the slave drive can accelerate from 0 to the speed specified in Parameter 716. This is input in milliseconds.

718 **Ramp type:** Specify here the ramp type to be used.

- 0 = linear ramp
- 1 = sinusoidal ramp

Please note that a sinusoidal ramp requires a greater acceleration torque than a linear ramp. On the other hand, a sinusoidal ramp produces less stress to the mechanics.

719 **Maximum track error:** Enter here the maximum track error. This is the permitted error between the calculated position and the feedback position. If the value is exceeded, the drive stops and displays the error message: O.ERR_8 "Position error". The value should be set higher than the permitted tolerance range ACCURACY in Parameter 733. Input in quad counts.

720 **Reversing behaviour:**

- 0 = means that the slave drive may always reverse, e.g. after overshooting the target position.
- 1 = the slave drive may only reverse when the master is reversing.
- 2 = the slave drive may never reverse.

721 **Slave marker type:** Select here the type of marker signal for the slave drive:

- 0 = rising edge of the zero track
- 1 = falling edge of the zero track
- 2 = rising edge at I6
- 3 = falling edge at I6

NOTE:

This parameter is only used in marker synchronizing mode (parameter 725 = 2 or 5).

722 **Marker interval at the slave:** Enter here the interval between two markers at the slave drive in quad counts. If this value is not known, it can be determined during the test run. For procedure, see description in the section "Testing the incremental encoders" in the packaging application example.

NOTE:

This parameter is only used in marker synchronizing mode (parameter 725 = 2 or 5).

723

Master marker type: Select here the type of marker signal for the master drive:

- 0 = rising edge of the zero track
- 1 = falling edge of the zero track
- 2 = rising edge at I5
- 3 = falling edge at I5.

NOTE:

This parameter is only used in marker synchronizing mode (parameter 725 = 2 or 5).

724

Marker interval at the master: Enter here the interval between two markers at the master drive in quad counts. If this value is not known, it can be determined during the test run. For procedure, see as described in the section “Testing the incremental encoders“ in the Loading belt, Marker synchronization, application example.

NOTE:

This parameter is only used in marker synchronizing mode (parameter 725 = 2 or 5).

725

Test run; Program 1:

Test run speed: Specify here the speed at which the test runs are to be carried out. The speed is specified as a percentage of the maximum speed defined in Parameter 716.

Synchronous operation; Program 2:

Type of operation: Select here the type of operation of the Synchronizing Controller:

Setting range:

- 0 = Speed synchronizing.
- 1 = Position synchronizing.
- 2 = Marker synchronizing.
- 3 = Speed synchronizing with motor coast after stop.
- 4 = Position synchronizing with motor coast after stop.
- 5 = Marker synchronizing with motor coast after stop.
- 6 = Speed synchronizing with motor coast after stop and setting of gear ratio via analogue input 54.
- 7 = Speed synchronizing with setting of gear ratio via analogue input 54.

With the selections “0” - “2” and “7” the motor is always controlled keeping the actual position when stopping synchronization (input 1 = “0”).

726

Test run; Program 1:

Test run acceleration: Specify here the acceleration for the test run as a percentage of the maximum acceleration. 100 % means that the drive accelerates with the minimum ramp specified in Parameter 717. 50 % means that the drive only proceeds with half the acceleration, i.e. the acceleration takes twice as long as with the minimum ramp specified in Parameter 717.

Synchronous operation; Program 2:

Hold function: If the contact at Terminal 29 is closed, the slave drive is disengaged, i.e. it no longer runs in synchrony with the master. If “0” is set, the slave drive is brought to the speed set in Parameter 727.

If “1” is set, the actual speed is maintained.

While these signals are present, the current Hold speed can be changed by means of Inputs 32 and 33.

727 *Test run; Program 1:*

Test run distance: Specify here the distance for the test run in quad counts.

Synchronous operation; Program 2:

Hold speed: If Hold function "0" was selected, enter here the speed as a percentage of the maximum speed (Parameter 716).

728 *Test run, program 1:*

Synchronizing type (Sync type): This parameter is used to specify the type of synchronization used when optimizing the PID controller for synchronization by means of the virtual master.

Setting range:

- 0 = Speed synchronizing
- 1 = Position synchronizing

Select "0" if you are going to use speed synchronizing in synchronous mode or select "1" if you are going to use position or marker synchronizing in synchronous mode.

Synchronous operation; Program 2:

Delta hold speed: Specify the percentage by which the hold speed is to change when Input 32 or 33 is activated during Hold mode.

729**Test run, program 1:**

Activate feed forward and PID calculation (FFVEL calc.): This parameter is used to trigger automatic calculation of the optimal value for velocity feed forward (par. 707) as well as PID sample time (par. 777), proportional factor (par. 702) and derivative factor (par. 703).

Setting range:

0 = No action.

1 = Activate calculation of velocity feed forward (par. 707).

The calculation is based on the following parameters that must be set before the calculation is started:

VLT5000:

Par. 104 "Nominal motor frequency",

Par. 205 "Maximum reference",

Par. 711 "Slave encoder type",

Par. 712 "Slave encoder resolution",

Par. 730 "encoder velocity",

Par. 777 "PID sample time".

VLT5000Flux:

Par. 711 "Slave encoder type",

Par. 712 "Slave encoder resolution",

Par. 730 "encoder velocity"

Par. 777 "PID sample time".

2 = Activate calculation of velocity feed forward (par. 707), PID sample time (par. 777), Proportional factor (par. 702) and derivative factor (par. 703).

The calculations are based on the following parameters that must be set before the calculation is started:

VLT5000:

Par. 104 "Nominal motor frequency",

Par. 205 "Maximum reference),

Par. 711 "Slave encoder type",

Par. 712 "Slave encoder resolution",

Par. 716 "Maximum velocity",

Par. 730 "encoder velocity".

VLT5000Flux:

Par. 711 "Slave encoder type",

Par. 712 "Slave encoder resolution",

Par. 716 "Maximum velocity",

Par. 730 "encoder velocity".

The parameter value is automatically reset to "0" when the calculation is done.

NOTE: If any of the above mentioned parameters are changed the calculation must be repeated.

Synchronous operation; Program 2:

Home function: Select how the drive is to behave on starting.

0 = the drive can synchronize from its current position;

1 = after switching on, and after an error, the drive must first be homed, from where it can synchronize,

2 = the drive must be homed before each synchronization.

730 *Test run, program 1:*

Encoder velocity (Encoder RPM): This parameter is used to specify the encoder velocity this is required for the velocity feed forward and PID calculation in parameter 729.

Setting range:
0 - 65000 RPM (Rotations Per Minute).

VL5000: The setting must be the encoder velocity in RPM corresponding to the nominal motor frequency in par. 104.

VL5000Flux: The setting must be the encoder velocity in RPM corresponding to the maximum reference in parameter 205.

Synchronous operation; Program 2:

Home speed: Set here, as a percentage of the maximum speed (Parameter 716), the speed for seeking the home position. Too high a home speed will impair the accuracy and repeatability.

731 *Synchronous operation; Program 2:*

Home acceleration: Specify here the acceleration for the homing as a percentage of the maximum acceleration. 100% means that the drive accelerates with the minimum ramp specified in Parameter 717. 50% means that the drive only proceeds with half the acceleration, i.e. the acceleration takes twice as long as with the minimum ramp specified in Parameter 717.

732 *Synchronous operation; Program 2:*

Marker synchronous operation: For marker synchronization, select how the slave is to synchronize to the master:

- 0 = last marker pulse, i.e. the slave synchronizes to the last detected marker pulse. This is achieved by accelerating to this position.
- 1 = next marker pulse: The slave waits for the next marker pulse and synchronizes to it.
- 2 = once the master speed is reached marker correction to next following markers take place (may catch up slow down).
- 3 = same as "0" but after master speed is reached.
- 4 = same as "1" but after master speed is reached.
- 5 = once the master speed is reached marker correction to closest marker take place.

If 1000 is added to the previous choices the fixed offset is not executed before the marker correction has taken place.

NOTE:

This parameter is only used in marker synchronizing mode (parameter 725 = 2 or 5).

733 Synchronous operation; Program 2:

Accuracy: This parameter specifies that maximum master - slave deviance, this is used to control the accuracy output (O 3). The accuracy output will only be high (24V) if the actual master - slave deviance is within this value.

In velocity synchronization (parameter 725 = 0, 3, 6 or 7) the value must be set in RPM (Rounds Per Minute) in all other modes it must be set in quad counts.

With a negative value in this parameter the synchronizing error (parameter 797) is shown with a sign otherwise the synchronizing error is unsigned.

734 Synchronous operation; Program 2:

Marker quantity FAULT: Enter when a FAULT signal (O2) must be set. Input the number of marker pulses, i.e. a setting of 10 means that ACCURACY must be low for 10 marker pulses before the FAULT signal is set

In position synchronization (parameter 725 = 1 or 4) only the slave marker is used; in marker synchronization (parameter 725 = 2 or 5) both slave and master marker must be detected before counting.

735 Synchronous operation; Program 2:

Marker quantity READY: Enter when a READY signal (O1) must be set. Enter the number of marker pulses, i.e. a setting of 10 means that ACCURACY must be present for 10 marker pulses before the READY signal is set.

In position synchronization (parameter 725 = 1 or 4) only the slave marker is used; in marker synchronization (parameter 725 = 2 or 5) both slave and master marker must be detected before counting.

736 Synchronous operation; Program 2:

M-S tolerance speed: Specify here the tolerated speed deviation between master and slave while the slave during synchronizing. The following apply here:

Slave must catch up: The slave can travel at the maximum permitted speed or at the speed: $\text{master speed} + \text{master speed} * \text{M-S tolerance speed} / 100$, whichever of the two is lowest.

Slave must slow down: The slave travels at the minimum speed: $\text{master speed} - \text{master speed} * \text{M-S tolerance speed} / 100$. If the M-S tolerance speed value is set to 50, the slave will not travel more slowly than half the master speed.

737 Synchronous operation; Program 2:

Gear ratio no.: Select the number of the gear ratio that you want to edit in Parameters 738 - 742.

738 Synchronous operation; Program 2:

Gear ratio numerator: Enter the numerator for the gear ratio selected in Parameter 737. Ensure that the gear ratio matches the marker ratio.

739 Synchronous operation; Program 2:

Gear ratio denominator: Enter the denominator for the gear ratio selected in Parameter 737. Ensure that the gear ratio matches the marker ratio.

740 Synchronous operation; Program 2:

Slave marker quantity: Enter the number of slave markers for the marker ratio. Ensure that the gear ratio matches the marker ratio.

NOTE:

This parameter is only used in marker synchronizing mode (parameter 725 = 2 or 5).

741 Synchronous operation; Program 2:

Master marker quantity: Enter the number of master markers for the marker ratio. Ensure that the marker ratio matches the gear ratio.

NOTE:

This parameter is only used in marker synchronizing mode (parameter 725 = 2 or 5).

742 Synchronous operation; Program 2:

Fixed offset: Enter the position offset. This makes it possible to compensate for differences in the placing of the encoder or markers. Input is in quad counts.

Note: Offset is related to the master position. Offset related to the slave position can be calculated as follows:

$$\text{Offset_slave} = \frac{\text{Offset} * \text{Parameter738}}{\text{Parameter739}}$$

743 Synchronous operation; Program 2:

Step time: Enter the time after which

- with the Hold function activated and the presence of one of the signals at Terminal 32 or 33, a change in speed takes place;
- in the engaged state, without Hold, the next change of the slave position takes place.

Input is in milliseconds.

744 Synchronous operation; Program 2:

Step Length: Enter the step value for changing the position offset in quad counts. Parameter 742 is changed accordingly.

745 Synchronous operation; Program 2:

Slave speed factor: Enter here the factor by which the slave speed must be scaled, so that the desired value is displayed. The following formula applies for calculation of the factor:

$$\text{Factor} = \frac{N_{\text{Set}} * 400 * \text{Slaveencoder_resolution}}{60 * \text{Display_value}}$$

Example: Resolution 1024 PPR, desired display 100 at 1500¹/_{min}

$$\text{Factor} = \frac{1500 \frac{1}{\text{min}} * 400 * 1024 \frac{\text{Incr.}}{\text{Rev.}}}{60 * 100} = \underline{\underline{102400}}$$

746 Synchronous operation; Program 2:

Master speed factor: Enter here the factor by which the master speed must be scaled, so that desired value is displayed. The formula for calculation of the factor is:

$$\text{Factor} = \frac{N_{Set} * 400 * \text{Masterencoder_resolution}}{60 * \text{Display_value}}$$

747 Synchronous operation; Program 2:

Synchronizing error display factor: Enter the factor by which the error must be scaled, so that the desired value is displayed. The formula for calculation of the factor is:

Speed synchronization: The factor should be 100, the synchronizing error is then displayed in RPM related to the slave.

Position synchronization:

$$\text{Factor} = \frac{*400 * \text{Slaveencoder_resolution}}{\text{Userunit}}$$

Example: Resolution 1024 PPR, user unit is 100 mm/revolution

$$\text{Factor} = \frac{*400 * 1024}{100} = 4096$$

748 Virtual master reference value: Select here the type of reference value for the virtual master.

- 0 = reference value signal 0.. ±10V via Terminal 53,
- 1 = reference value signal 0.. ±20mA via Terminal 60,
- 2 = reference value can be set via Parameter 216.
- 3 = reference value is set via Field bus (PCD 2). +/- 1000 corresponds to maximum virtual master velocity (parameter 750).

749 Virtual master acceleration: Enter here the acceleration for the virtual master in Hz/s.

$$\text{Virtual master acceleration} = \frac{\text{Pulsfrequency[Hz]}}{t[s]}$$

Example: The virtual master must correspond to an encoder with 1024 inc/rotation. The maximum speed of 25 encoder rotations per second must be attained in 1 second.

$$\text{Virtual master acceleration} = \frac{25 \frac{1}{s} * 1024 \frac{\text{Incr.}}{\text{Rev.}}}{1s} = \underline{25600 \text{ Hz/s}}$$

750 Virtual master maximum speed: Enter here the maximum speed of the virtual master in Hz.

$$\text{Virtual master maximum speed} = \frac{\text{Increments}}{\text{Rev.}} * \frac{\text{Rev.}}{s}$$

Example: The maximum virtual master signal must correspond to an incremental encoder with 1024 inc/rotation at a rotational speed of 50 rotations/s.

$$\text{Virtual master maximum speed} = \frac{1024}{1} * \frac{50}{s} = \underline{51200 \text{ 1/s}}$$

751

Marker window slave: Here you can enter how large the permitted tolerance for the occurrence of the marker is. The factory setting "0" means all markers are used. At every other setting only those markers are accepted which are within the window.

Example: Marker interval = 30000 and marker window = 1000. Only markers with an interval of 29000 to 31000 is accepted.

NOTE:

This parameter is only used in marker synchronizing mode (parameter 725 = 2 or 5).

752

Marker window master: Here you can enter how large the permitted tolerance for the occurrence of the marker is. The factory setting "0" means all markers are used. At every other setting only those markers are accepted which are within the window.

Example: Marker interval = 30000 and marker window = 1000. Only markers with an interval of 29000 to 31000 is accepted.

NOTE:

This parameter is only used in marker synchronizing mode (parameter 725 = 2 or 5).

753

Control source test run (Contr. testrun):

This parameter is used to select the control source in test run mode (par. 701 = "1"). There can only be one control source at a time: Digital inputs or field bus control word. Only exception is input 27 which is always stop also with field-bus control.

When digital control is selected status signals are updated on the digital outputs, when field bus control is selected status signals are updated on digital outputs as well as field bus.

Setting range:

- 0 = Digital inputs
- 1 = Field bus

"0" means that all control commands are activated via the digital inputs according to the description of the terminals.

"1" means that all control commands are activated via the field bus control word according to the description of field bus control.

NOTE: The new control source selected in par. 753 is not active before next power up (power cycle), remember to save (par. 710 or input 4) the settings before power down.

754 Control source synchronizing (Contr. synchron):

This parameter is used to select the control source in synchronizing mode (par. 701 = "2"). There can only be one control source at a time: Digital inputs or field bus control word. Only exception is input 27 which is always stop also with field-bus control.

When digital control is selected status signals are updated on the digital outputs, when field bus control is selected status signals are updated on digital outputs as well as field bus.

Setting range:

- 0 = Digital inputs
- 1 = Field bus

"0" means that all control commands are activated via the digital inputs according to the description of the terminals.

"1" means that all control commands are activated via the field bus control word according to the description of field bus control.

NOTE: The new control source selected in par. 754 is not active before next power up (power cycle), remember to save (par. 710 or input 4) the settings before power down.

755 Brake on delay (Brake on delay):

This parameter is used to specify the delay time between closing the mechanical brake (output 4) and disabling motor control (motor coast). This is necessary to avoid losing the load because of the reaction time of the mechanical brake.

Setting range:

0 ... 5000 msec.

The value must be set according to the reaction time of the mechanical brake.

756 Brake off delay (Brake off delay):

This parameter is used to specify the delay time between activating motor control and opening the mechanical brake (output 4). This is necessary to avoid losing the load because of the reaction time of the mechanical brake.

Setting range:

0 ... 5000 msec.

The value must be set according to the reaction time of the mechanical brake.

775 Synchronous operation, program 2:

Track error (read only): This parameter indicates the actual PID error during synchronization (same as par. 797 in test-run mode).

776 Input status (read only):

Digital control (par. 753 and par. 754): This parameter is showing the actual status of the 8 digital inputs (I1 - I8) on MK3A as a binary code.

Example:

Input 3,7 and 8 high
776 = 11000100
Input 1 and 3 high
776 = 101

Field bus control (par. 753 and par. 754): This parameter is showing the status of the field bus control word (PCD 1) as a decimal value.

Example:

Bit 3,7 and 8 high
776 = 196
Bit 1 and 3 high
776 = 5

777 PID-sample time

The parameter is setting the sample time of the control algorithm. The value should be increased if:

- The pulse frequency is very low, e.g. 1 to 2 quad counts per sample time (you need at least 10 to 20 quad counts per sample time).
- The system is very slow and heavy (high inertia). Controlling systems with 1 ms can make big motors vibrate.

The correct value can be calculated automatically, see test run parameter 729.

NOTE!

The parameter setting has direct influence on the PID loop; if you for example double the Sample time the P-portion (parameter 702) also has the double effect.

The following are display parameters only (read only)

778 Status of Synchronization

The following status flags are defined for position and marker synchronization. The flags are not updated when using speed synchronization:

Flag:	Decimal value	Bit
SYNCREADY	1	0
SYNCFAULT	2	1
SYNCACCURACY	4	2

Only marker Synchronization:

Master marker HIT	8	3
Slave marker HIT	16	4
Master marker Error	32	5
Slave marker Error	64	6

The flags are reset when restarting synchronization (SyncStart).

SYNCACCURACY

Each millisecond it is checked if the actual position deviance between master and slave is smaller than parameter 733(accuracy), if this is true the SYNCACCURACY flag is set (1), otherwise the flag is reset. (0).

SYNCFAULT / SYNCREADY

For every marker pulse it is checked whether the SYNCACCURACY flag is present or not. If it is not present the fault counter is increased and the ready counter set to 0, if it is present the ready counter is increased and the fault counter set to 0.

If the ready counter is higher than the value set in parameter 735 (marker quantity ready) then the flag SYNCREADY is set, if not the flag is reset.

If the fault counter is higher than the value in parameter 734 (marker quantity fault) the flag SYNCFAULT is set (1), if not the flag is reset (0).

Marker HIT flags:

The marker HIT flags are set (1) after detecting n marker pulses (n = parameter 740 and 741).

Marker error flags:

It is checked at each n marker pulse (n = parameter 740 or 741) whether the distance between the actual marker position and the last registered marker position is lower than 1.8 times the value of parameter 722 or 724. If this is not true, then the associated flag is set. (1). When using marker windows (par. 751 and 752) it is checked whether a marker is detected within the window. If no marker is detected the error flag is set (1).

779 Software version number:

The software version of the synchronizing controller in use appears here.

795 “Slave position”: The slave position is displayed in quad counts.

796 “Master position”: The master position is displayed in quad counts.

797 *Test run; Program 1:*

“**Track error**“: The track error is displayed in quad counts.

Synchronous operation; Program 2:

“**Sync-error**“: The synchronization error is displayed with the value calculated in Parameter 747.

798 “**Slave speed**“: The slave speed is displayed with the value calculated in Parameter 745.

799 “**Master speed**“: The master speed is displayed with the value calculated in Parameter 746.

Initializing the parameters

It is possible to restore parameter default values by means of the initialise function in parameter 620. All parameter except parameter 500, 501, 600-605, 615-617 will be reset to factory default setting.

NOTE: The VLT must be in stop mode before initialising can be carried out.

Procedure for initialising:

1. Select initialise in parameter 620
2. Press the [OK] key
3. Set parameter 710 to “1”. Wait until it changes to “0”(app. 0.5 sec)
4. Switch off mains supply and wait until the display is dark
5. Switch on the mains supply

Speed synchronization

The speed synchronization controller raise or lower the speed of the slave drive matching it to the calculated master speed taking the gear ratio into account. – There is no position control.

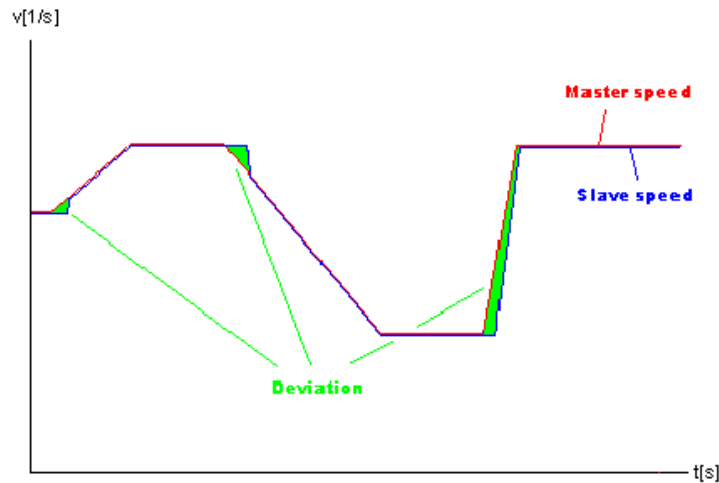

Figure 8: Control behaviour with speed synchronization

In the above diagram, it can be seen that the slave drive is following the speed of the master drive. Note: Position deviations arising in connection with speed changes are not adjusted. This type of control could for example be used for dosing pumps mixing two liquids. See example.

The example shows a batching unit where an admixture to a basic substance is carried out. The mixing proportion is freely selectable by means of the gear ratio. The advantage of pure speed synchronizing control can also be seen, as it makes little sense to compensate for position deviations that arise (i.e. too large an amount of Product B being added, for example) by means of reducing the speed of the slave drive, as that would only lead to an insufficient amount of Product B being added subsequently.

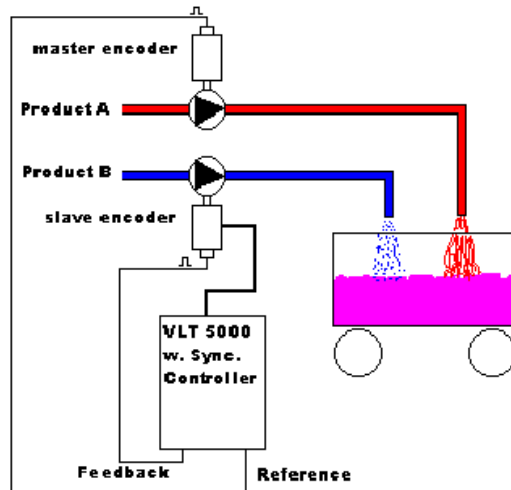

Figure 9: Mixing. Speed synchronizing control

Function diagrams for speed synchronization

SyncStart

When closing the SyncStart contact (Terminal I1), the slave drive accelerates with minimum ramp time to the speed of the master drive, taking the gear ratio into account. When I1 is opened, the slave drive ramp or coast to stop. Stop behaviour is selected in parameter 725.

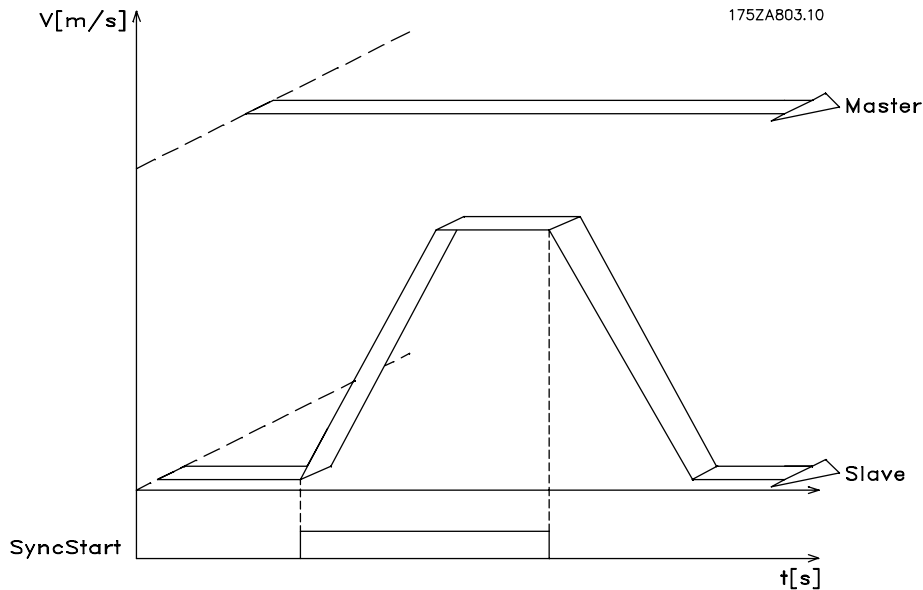

Figure 10: SyncStart with speed synchronization

Up/down factor

After the slave has been synchronized to the speed of the master by means of SyncStart (Terminal I1), the gear ratio can be changed during operation. By means of Inputs 33 Speed+ / Up-factor, or 32 Speed- / Down-factor, the gear ratio can be changed by the value set in Parameter 744 (step width). This change affects only the slave factor. For more sensitive adjustment of the gear ratio, the gear ratio digits should be extended and a small step width should be selected.

If one of the two inputs is on longer than the time defined in Parameter 743 (step time), a further step will be executed.

Example:

Gear ratio $i = 22:43$

If the step width is equal to 1, the first upward step will result in $i = 22:44$, which represents almost 3%. It would be better to set the ratio as $i = 2200:4300$. Then the upward step will result in $i = 2200:4301$, which represents a change of approx. 0.03%.

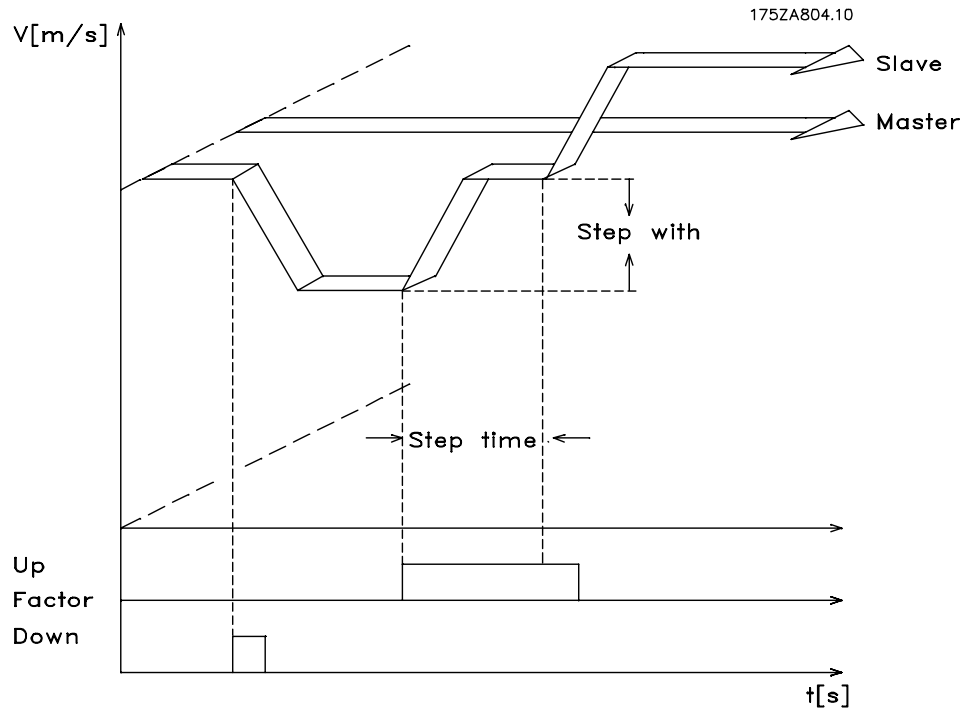

Figure 11: Up/down factor with speed synchronization

Hold function

The Hold function operates the slave drive in closed loop speed control at a speed independent of the master. With Parameter 726 (Hold function) you can choose whether the slave is to run at a fixed speed set in Parameter 727 or whether it is to maintain current speed. For the duration of the Hold signal, the speed of the master is no longer taken into account; the master can even stop without this having any effect on the slave drive. While the Hold function is activated you can change the speed with inputs 32 and 33. The speed is changing according to the settings in parameter 728(Delta hold speed) and parameter 744(Step width).

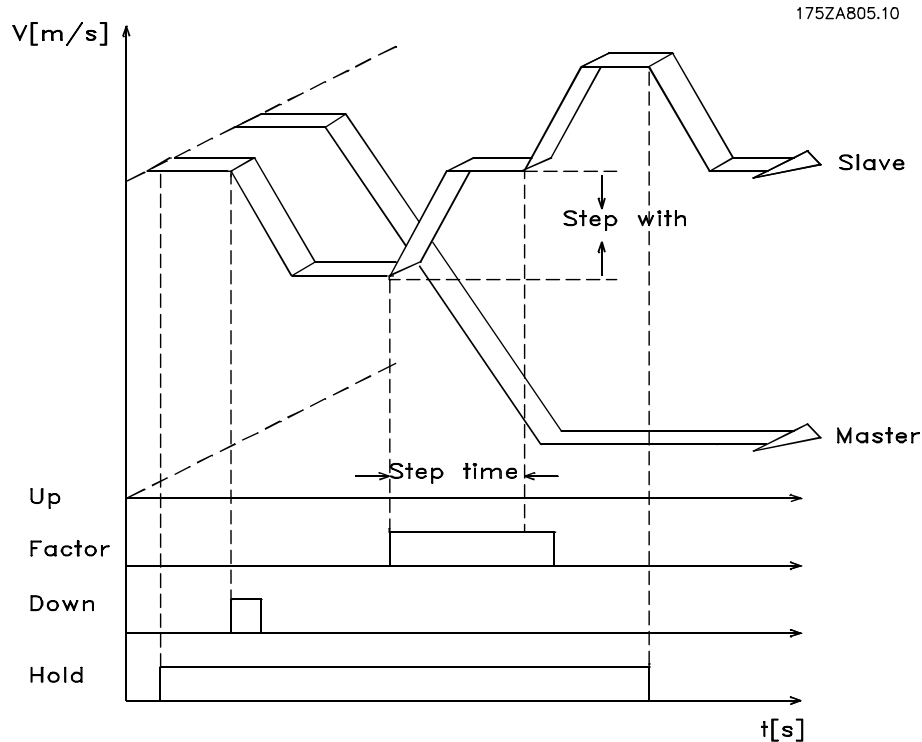

Figure 12: Hold speed

Gear changing

During synchronous operation, it is possible to switch between 4 fixed gear ratios, set in parameters 737 - 739. The fixed gear ratios are selected at terminals 16 and 17:

Input 16	Input 17	Gear ratio #
0	0	0
0	1	1
1	0	2
1	1	3

To activate the new ratio you must activate input I2. The newly set gear ratio is attained with the minimum possible ramp.

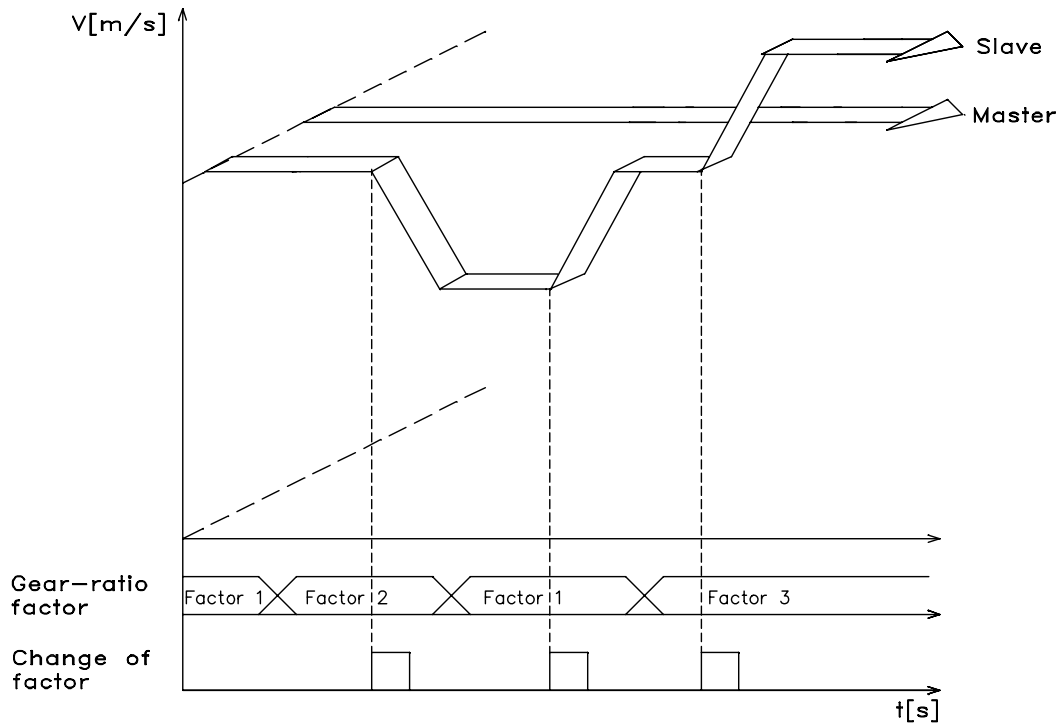

Figure 13: Changing the gear ratio in speed synchronization

Changing the gear ratio with an analogue value

As an alternative the gear ratio can be set via analogue input 54 with a +/- 10V signal, this function is active when synchronizing type 6 or 7 is selected in parameter 725.

The gear ratio denominator is fixed to 500. The gear ratio numerator is set by input 54, 5V corresponds to 500 which then gives a gear ratio of 1:1.

Application example – Admixture

A feed screw conveyor pump leads substance 1 to a nozzle adding substance 2. For different end products it must be possible to select different mixing ratios (ratio 1 = 1:1; ratio 2 = 1:1.12; ratio 3 = 1:1.2; ratio 4 = 1:1.21). During operation it must be possible manually to make slight adjustments of the selected mixing ratio.

Description of terminals and terminal configuration

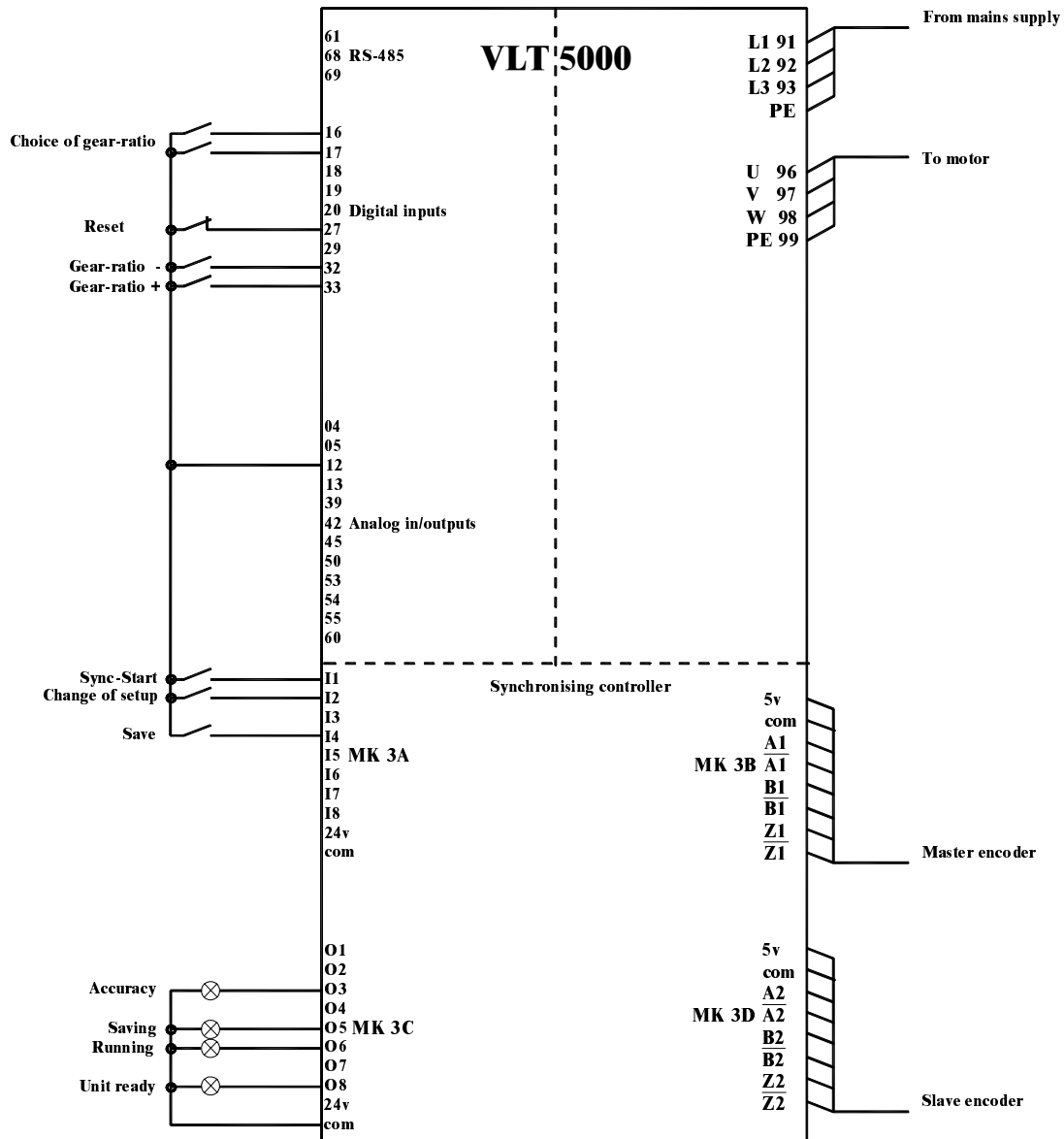

Figure 14: Wiring diagram – Batch control

Setting the parameters

For this work we recommend you to have the description of parameters at hand. **See the VLT 5000/VLT5000Flux Operating Instructions.**

NOTE: It is very important that the VLT is optimized for the motor before optimizing the Synchronizing controller. First you record the motor data and perform an AMA (Automatic Motor Adaptation) if possible and then you can start programming your synchronization functions.

Parameter 205 Maximum reference: Set the frequency for a value that is about 10% higher than the maximum value of parameter 716.

Example:

Motor 7.5 kW, 1460 $\frac{1}{\text{min}}$ at 50 Hz, speed of the application approx. 1800 $\frac{1}{\text{min}}$

$$\frac{f_{Nom} * N_{Application}}{N_{Nom}} * 1,1 = \frac{50\text{Hz} * 1800 \frac{1}{\text{min}}}{1460 \frac{1}{\text{min}}} * 1,1 = \underline{62\text{Hz maximum ref. value}}$$

Parameter 221 Torque limit for motor mode: Set for maximum. – Choose a lower value, if special safety precautions are necessary.

Parameter 222 Torque limit for regenerative operation: Set for maximum. – Choose a lower value, if special safety precautions are necessary

Parameter 701 Record “1” to start the test program.

Parameter 709 This parameter configures the velocity filter for speed synchronization. Since speed synchronization is based on speed a small fluctuation in master speed, when running at low speed, can have an effect on the pid loop control. Hence this filter will even out the effect.

$$\text{Cmdvel} = \text{Old_Cmdvel} + (\text{Actvel} - \text{Old_Cmdvel}) * \text{ms}/\text{tau_filt}$$

Cmdvel = set velocity

Old_Cmdvel = last set velocity

Actvel = actual velocity of master

ms = sample time (parameter 777)

tau_filt = filter time constant

For standard encoders the following table can be used:

Encoder resolution	Tau_filt (ms)
250	39500
256	38600
500	19500
512	19000
1000	9500
1024	9300
2000	4500
2048	4400
2500	3500
4096	1900
5000	1400

- Parameter 711 Record the type of slave encoder. "0" represents the incremental encoder.
- Parameter 712 Record the resolution of the slave encoder.
- Parameter 713 Record the type of master encoder. "0" represents the incremental encoder.
- Parameter 714 Record the resolution of the master encoder.
- Parameter 715 Record "1" for clockwise rotation of both master and slave. Record "-1" if the slave is to run in the opposite direction.
- Parameter 716 Record maximum RPM measured at the slave encoder.
- Parameter 717 Minimum ramp: Set the time in Ms for the slave drive to accelerate from standstill to maximum speed (par 716). This value is important as this setting highly affects the control accuracy!
- Parameter 718 Ramp type: Record "0" for linear ramp and "1" for s-ramp. **NOTE:** S-ramp requires higher acceleration torque.
- Parameter 720 Reversing behavior: Record "0" if reversing is allowed, "1" if the slave must always follow the direction of the master or "2" if reversion is not allowed.

How to check the motor connection

When you have programmed the above parameters you check the motor connection as follows:

1. Remove all signals to terminals 16-33 and I1-I8.
2. Select "LCP control / open loop "1" in parameter 013. Select "Local" function in Parameter 002. – VLT 5000 stops (display flashing)
3. Set the frequency for a low value, for example 3 Hz in Parameter 003
4. Press the [START] button on the VLT 5000 control panel and then [the [STOP/Reset] button watching the speed direction of the motor. If the motor rotates in the wrong direction then exchange the motor phases.

How to test the incremental encoders

When you have tested the motor speed direction you test the incremental encoder connection as follows:

1. Remove all signals to terminals 16-33 and I1-I8.
2. Press the [DISPLAY/STATUS] button on the VLT 5000 control panel. Now the following values appear in the upper line of the display: slave position, master position and track error.
3. Rotate the slave drive motor shaft manually in the forward direction. Now the display shows an ascending count of the slave position. If the count is descending, exchange the slave encoder track A by B and A/ by B/. If there is no counting in the display then check the wiring of the encoder.

Follow the same procedure when you test the master encoder.

Remember to change parameter 002 back to "Remote" and start VLT 5000 by pressing the [START] button on the control panel.

How to optimize the controller:

Synchronization is obtained via two main elements of the controller: Velocity feed forward and the PID controller.

NOTE: Before starting the optimizing procedures it is important to select the right type of synchronization in parameter 728, in this example it must be "0" for velocity synchronization. Please always have the necessary degree of accuracy in mind, you could go on optimizing for a long time, but it might not be necessary to have a 100% accuracy in the application you are dealing with.

First step is to optimize velocity feed forward this can be done via the automatic calculation function:

Velocity feed forward calculation is activated by setting parameter 729 to "1", remember to make the required parameter settings according to the description of par. 729 before starting the calculation. The calculation is done when the value of par. 729 returns to "0".

Velocity feed forward can also be optimized manually by the following procedure:

1. Set parameter 706 PID bandwidth to "0".
2. Set parameter 719 maximum track error to a high value (e.g. 1,000,000).
3. Set parameter 707 velocity feed forward to 100.
4. Start test-run with virtual master with a known velocity via input 3 = 1.
5. Increase parameter 707 while watching master and slave velocity (press [DISPLAY/STATUS] to get the velocity readouts). You have found the optimal velocity feed forward when slave velocity is approximately equal to the master velocity.
6. Stop test-run by input 3 = 0.
7. Reset parameter 719 to the original value.
8. Reset parameter 706 to 1000.

Second step is to optimize the PID controller, a good starting point can be found by means of the automatic calculation function:

By setting parameter 729 to "2" velocity feed forward calculation is activated as well as calculation of PID sample time and P/D factors, remember to make the required parameter settings according to the description of par. 729 before starting the calculation. The calculation is done when the value of par. 729 returns to "0".

Using the test run functions can optimize the PID factors further:

There are two types of test run available: Positioning where the slave drive moves a specific distance and Synchronizing with virtual master where the slave follows the virtual master in position or speed. Generally it is better to use test run with virtual master as that comes closer to the operating conditions in synchronizing mode (program 2).

For test run with positioning the following parameters must be set:

Parameter 725 Test run speed: Record the speed as a percentage of the maximum speed of parameter 716.

Parameter 726 Test run acceleration: record the acceleration time in per cent. 100% is minimum acceleration. 50% is half as fast as minimum acceleration, the ramp time will thus be twice as long.

Parameter 727 Test run distance: Record the distance (quad counts) for the drive to run during optimization.

Then use the following procedure:

1. Close the contacts at terminal 32 (clockwise/forward direction) or terminal 33 (counter-clockwise/reverse). During the test the last value of the first display line will indicate the track error (PID error). After the test run is completed you can see the maximum track error (PID error) in the display.
2. Increase the P-portion (par. 702). After each change you should make a test run to find the right setting. If the drive becomes unsteady or if a message is given about over-voltage or over-current, then reduce the value in parameter 702 to about 70-80% of the set value.
3. Now set the D-portion (parameter 703) to 5 times the value of parameter 702.
4. If a lower synchronizing error is required the I-portion (parameter 704) can be set to a low value e.g. 10 but be careful a too high value will course overshoot and instability.

For test run with virtual master the following parameters must be set:

Parameter 748 Virtual master reference: Select the reference source for setting the velocity of the virtual master. "0" is analogue input 53, "1" is analogue input 60, "2" is parameter 216 and "3" is Field bus PCD 2.

Parameter 749 Virtual master acceleration: Set the acceleration of the virtual master in encoder pulses per second².

Parameter 750 Virtual master maximum speed: Set the maximum velocity of the virtual master in encoder pulses per second.

Then use the following procedure:

1. Disconnect the master encoder from the synchronizing controller (MK3B). Start test run with virtual master by activating input 3. During test run you can read the track error in the last value of the first display line. At stop the maximum track error during the test run is read out. Because velocity synchronization is selected (parameter 728 = 0) the track error is velocity deviance between master and slave.
2. If more accurate and dynamic control is required the P-portion (parameter 702) must be increased. If the slave becomes unstable the value must be reduced to by approximately 25%.
3. Now set the D-portion (parameter 703) to 5 times the value of parameter 702
4. If a lower synchronizing error is required the I-portion (parameter 704) can be set to a low value e.g. 10 but be careful a too high value will course overshoot and instability.

To store the optimized values

Activate Input I4 (Store) or change the value of parameter 710 to "1"

How to program synchronization

Change the value of parameter 701 to "2". This will start the synchronization program of VLT 5000/VLT 5000 Flux.

To do the synchronization programming you use the following parameters:

- Parameter 725 Type of operation: Record "0" or "3" for speed synchronization.
- Parameter 726 Hold function: Specify how the drive is to react when Input 29 is activated . "Hold" switches the drive from master synchronization to a fixed frequency. Choose "0" to use the frequency set in par. 727 and "1" to use the current frequency.
- Parameter 727 Hold speed: Set here, as a percentage of the maximum speed, the speed at which the drive should move when you activate Hold and the value "0" was selected in Parameter 726.
- Parameter 728 Delta hold speed: Set here the step width by which the hold speed is to be changed upwards or downwards by activating Terminals 32 + 33.
- Parameter 737 Gear ratio No.: Record the number of the gear ratio that is to be displayed in Parameters 738 to 739. Then you set the values required in Parameters 738 to 740. Follow the same procedure for the next gear ratio(s).
- Parameter 738 Gear ratio numerator: Record the numerator value of the gear ratio. That is the encoder pulses of the slave drive. To make fine adjustment possible by means of inputs 32 and 33 a ratio of for example 7:16 must be programmed as 7000:16000.
- Parameter 739 Gear ratio denominator: Enter here the denominator value of the gear ratio. This value corresponds to the master pulses.
- Parameter 743 Step time: In Hold mode, the next frequency change and, in synchronization mode, the next change of the counter factor of the gear ratio, is carried out after this time, on the presence of one of the signals at terminal 32 or 33. The time input is in milliseconds.
- Parameter 744 Step width: In speed synchronization, the gear ratio numerator is changed by this amount, if one of the terminals 32 or 33 is closed.
- Parameter 745 Slave speed factor: Record the factor by which the slave speed must be multiplied, so that it can be displayed. Use the following formula:

$$\text{Factor} = \frac{N_{\text{Set}} * 400 * \text{Slaveencoder_resolution}}{60 * \text{Display_value}}$$

Example:

Resolution 1024 increments, desired display 100 at 1500¹/min

$$\text{Factor} = \frac{1500 \frac{1}{\text{min}} * 400 * 1024 \frac{\text{Incr.}}{\text{Rev.}}}{60 * 100} = \underline{\underline{102400}}$$

Parameter 746 Master speed factor: Record the factor by which the master speed must be multiplied, so that it can be displayed. Use the following formula:

$$\text{Factor} = \frac{N_{Set} * 400 * \text{Masterencoder_resolution}}{60 * \text{Display_value}}$$

Parameter 747 Synchronizing error display factor: This factor must be 100, the synchronizing error is then displayed in RPM related to the slave.

Store your data settings by means of Store Input (I4) or by changing Parameter 710 to "1".

Operation and operating functions

After all the values have been set as described and the controller optimized for the application, normal operation can begin.

Starting synchronization

Synchronization with the master is achieved by closing the SyncStart contact (I1); the drive accelerates the maximum permitted acceleration to the speed of the master (calculated by means of the gear ratio).

Stopping synchronization

When the SyncStart contact (I1) is opened, the slave is stopped at the permitted acceleration.

Fine setting of the gear ratio

Fine setting of the gear ratio can now be undertaken by means of Inputs 32 + 33. This setting is only temporary, i.e. the fine setting data will be lost as soon as VLT 5000 is disconnected from the mains. If the setting is to be saved, a Store operation must be carried out by closing the Store contact (I4) or by means of Parameters 710 before the VLT 5000 is switched off.

Switching to another gear ratio

During synchronization, a new gear ratio can be selected at Inputs 16 and 17. The gear ratio is then activated by means of the Switching Input (I2). The slave will then proceed at the permitted acceleration to this new gear ratio.

Error procedure

Errors of tracking, over current etc. make the drive stop and the Ready output (O8) is reset.

Reset is done with Input 27 or fieldbus bit 1.9.

Reset is also possible with the [STOP/RESET] key of the local control panel of the drive. This is only possible if the local stop function is disabled in parameter 014.

Note: You cannot stop the drive via the local control panel if local stop is disabled.

In case the drive has stopped because of earth fault or short-circuit, do disconnect the drive from the mains before you reset!

Position synchronization (angle synchronization)

The position controller adjusts the slave drive position or angle to the master.

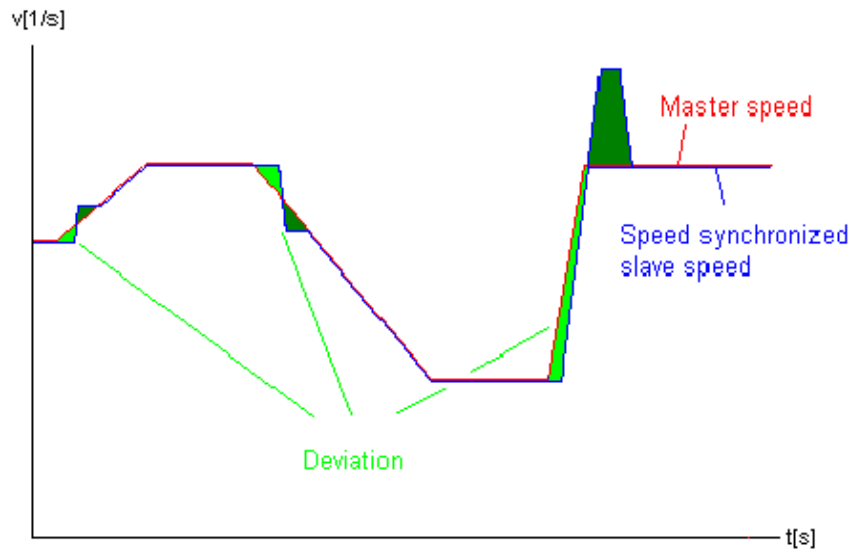

Figure 15: Control behaviour with position synchronization

It appears from the diagram that the control accuracy depends on the master acceleration and on the speed deviation between slave and master. A typical application for this type of synchronizing could be the replacement of a mechanical shaft. Or mixing controls where a mixing rate is required.

The following example shows how embossing patterns on moulds is controlled. This application requires accurate position control.

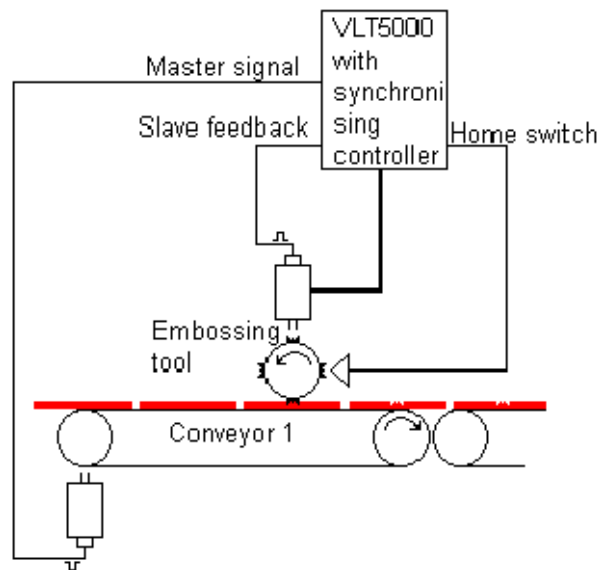

Figure 16: Embossing with position synchronization

Function diagrams for position synchronization

SyncStart to a stationary master

If the slave is synchronized to a stationary master drive, the slave will remain stationary. However, if a fixed offset is defined for the activated gear ratio, the slave travels to the extent of this offset during synchronization.

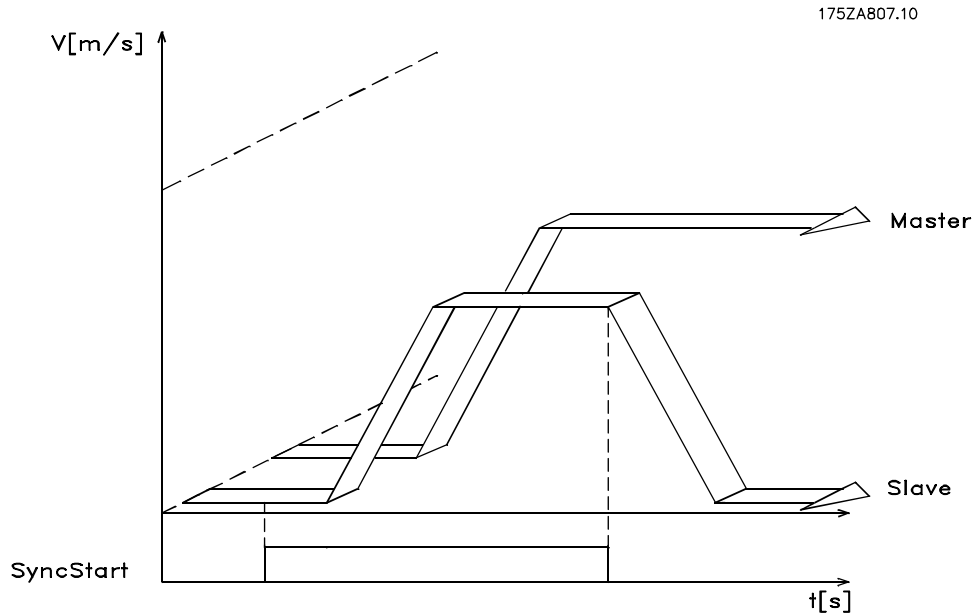

Figure 17: Synchronizing to a stationary master

SyncStart to a running master

If synchronization is effected to a running master, the slave drive first makes up the deviation of distance then it proceeds synchronously with the master. Any Offset setting is taken into account.

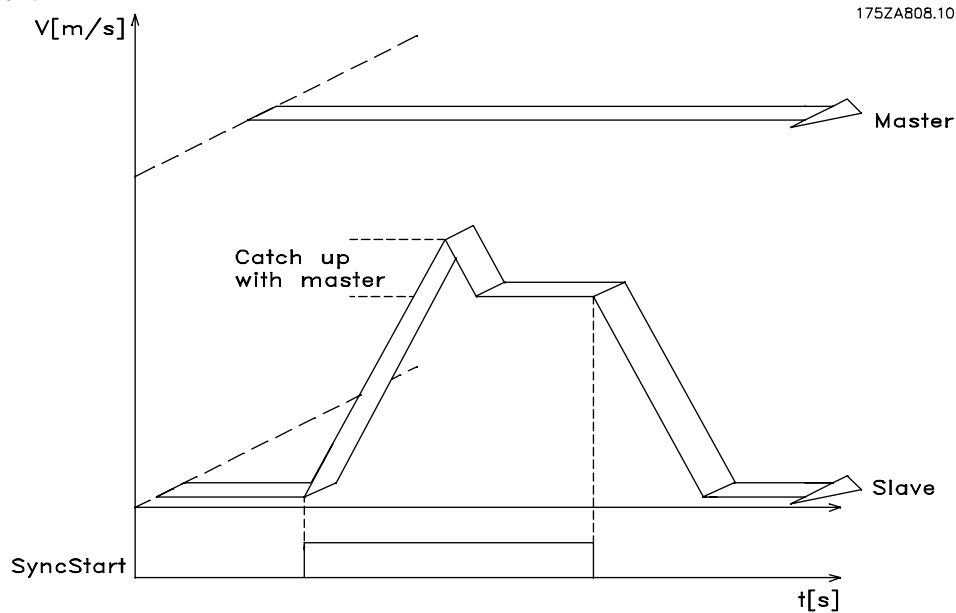

Figure 18: Synchronizing to a running master

Position displacement with a running master

If one of the Inputs 32 or 33 is activated during synchronous travel, the actual position in relation to the master is displaced by the value set in Parameter 742. If the displacement is positive, the slave accelerates in order to travel the necessary distance in order then again to travel synchronously to the master at the speed determined via the gear ratio. If the displacement is negative, the slave decelerates in order to attain the necessary distance to then again travel synchronously with the master at the speed determined via the gear ratio.

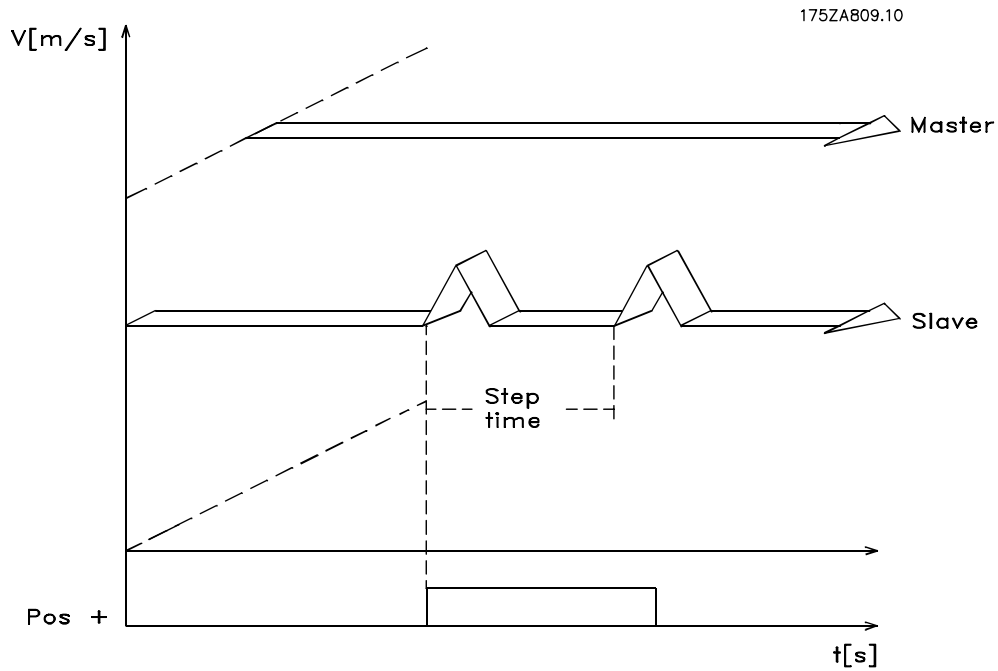

Figure 19: Position displacement

Application example – Embossing patterns on mould

Moulds of two different kinds and lengths are embossed with a pattern. The conveyor belt operator changes the position of the pattern by means of two buttons. Each of the two incremental encoders has a zero track for marker synchronization.

Description of terminals and terminal configuration

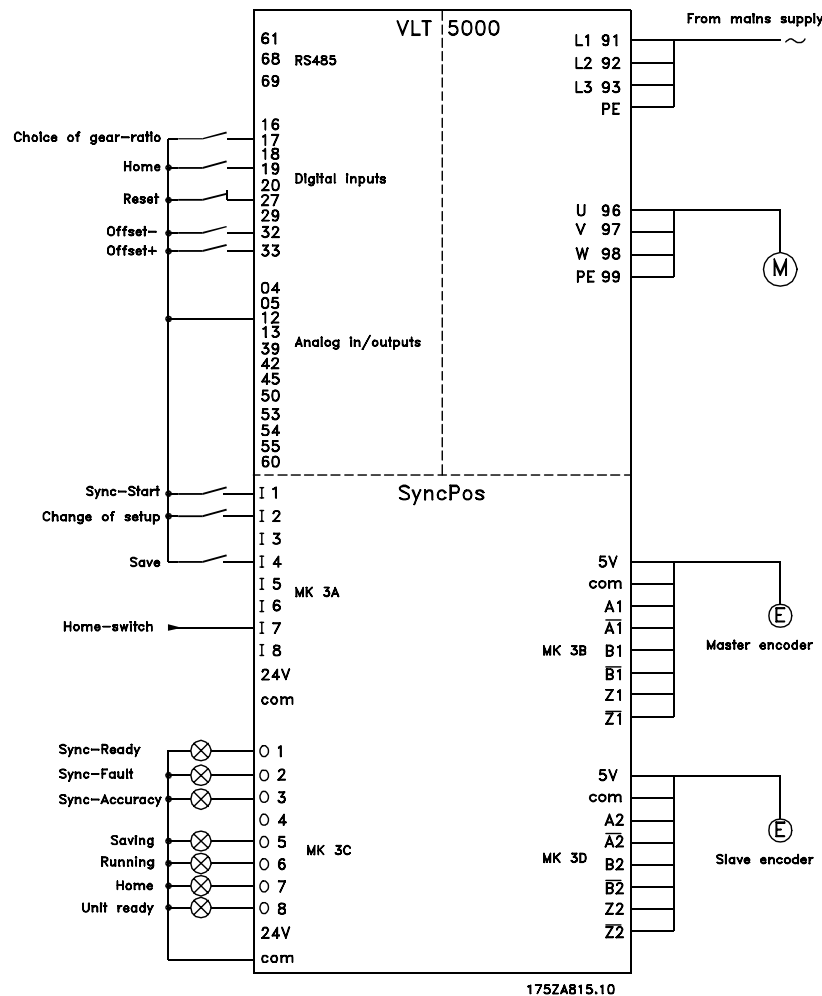

Figure 20: Wiring diagram – application example

Setting the parameters

For this we recommend you to have the description of parameters at hand. **See the VLT 5000/VLT5000Flux Operating Instructions.**

NOTE: It is very important that the VLT is optimized for the motor before optimizing the Synchronizing controller. First you record the motor data and perform an AMA (Automatic Motor Adaptation) if possible and then you can start programming your synchronization functions

Parameter 205 Maximum reference: Set the frequency for a value that is about 10% higher than the maximum value of parameter 716.

Example:

Motor 7.5kW, 1460 $\frac{1}{\text{min}}$ at 50Hz, speed of the application approx. 1800 $\frac{1}{\text{min}}$

$$\frac{f_{Nom} * N_{Application} * 1,1}{N_{Nom}} = \frac{50Hz * 1800 \frac{1}{\text{min}} * 1,1}{1460 \frac{1}{\text{min}}} = 62Hz \text{ Maximum ref. value}$$

Parameter 221 Torque limit for motor mode: Set for maximum. – Choose a lower value, if special safety precautions are necessary.

Parameter 222 Torque limit for regenerative operation: Set for maximum. – Choose a lower value, if special safety precautions are necessary.

Parameter 223 Set the minimum current that is to activate the brake. Choose a value that is below the motor magnetisation current.

Parameter 701 Record “1” to start the test program.

Parameter 709 When performing position synchronization this parameter is used to insert a filter to compensate for an oscillating master signal. If, for example, the master is experiencing shock loads the pid loop of the synchronizing controller will have a tendency to oscillate as well. A negative value must be entered.

Example:

If a filter factor of –100000 (100 ms) is used the correction is balanced within: 1000/(filter factor *10)= 1 second.

Parameter 711 Record the slave encoder type. “0” represents the incremental encoder.

Parameter 712 Record the resolution of the slave encoder.

Parameter 713 Record the master encoder type. “0” represents the incremental encoder.

Parameter 714 Record the resolution of the master encoder.

Parameter 715 Record “1” for clockwise rotation of both master and slave. Record “-1” if the slave is to run in the opposite direction.

Parameter 716 Record maximum RPM measured at the slave encoder.

Parameter 717 Minimum ramp: Set the time in ms for the slave drive to accelerate from standstill to maximum speed (par 716). The value is important, as this setting highly affects the control accuracy!

- Parameter 718 Ramp type: Record “0” for linear ramp and “1” for s-ramp. **Note:** S-ramp requires higher acceleration torque
- Parameter 719 Maximum track error: Record the value that is to generate “Track error” indication in the display, if exceeded. Input is in quad counts.
- Parameter 720 Reversing behaviour: Record “0” if reversing is allowed, “1” if the slave must always follow the direction of the master or “2” if reversing is not allowed.

How to check the motor connection

When you have programmed the above parameters you check the motor connection as follows:

1. Remove all signals to terminals 16-33 and I1-I8. Only input 27 must be connected and closed.
2. Select “Local” function in Parameter 002. – VLT 5000 stops (display flashing)
3. Set the frequency for a low value, for example 3 Hz in parameter 003.
4. Press the [START] button on the VLT 5000 control panel and then the [STOP/RESET] button watching the speed direction of the motor. If the motor rotates in the wrong direction then exchange the motor phases.

Testing the incremental encoders

When you have tested the motor speed direction you test the incremental encoder connection as follows

1. Remove all signals to terminals 16-33 and I1-I8. Only Input 27 must be connected and closed.
2. Press the [DISPLAY/STATUS] button on the VLT 5000 control panel. Now the following values appear in the upper line of the display: slave position, master position and track error.
3. Rotate the slave drive motor shaft manually in the allowed direction. Now the display shows an ascending count of the slave position. If the count is descending, exchange the slave encoder track A by B and A/ by B/. If there is no counting in the display then check the wiring of the encoder.

Follow the same procedure when you test the master encoder. **Note:** To be right the count must be ascending here.

Remember to change parameter 002 back to “Remote” and start VLT 5000 by pressing the [START] button on the control panel.

How to optimise the controller

Synchronization is obtained via two main elements of the controller: Velocity feed forward and the PID controller.

NOTE: Before starting the optimizing procedures it is important to select the right type of synchronization in parameter 728, in this example it must be “1” for position synchronization.

Please always have the necessary degree of accuracy in mind, you could go on optimizing for a long time, but it might not be necessary to have a 100% accuracy in the application you are dealing with.

First step is to optimise velocity feed forward this can be done via the automatic calculation function:

Velocity feed forward calculation is activated by setting parameter 729 to “1”, remember to make the required parameter settings according to the description of par. 729 before starting the calculation. The calculation is done when the value of par. 729 returns to “0”.

Velocity feed forward can also be optimized manually by the following procedure:

1. Set parameter 706 PID bandwidth to "0".
2. Set parameter 719 maximum track error to a high value (e.g. 1.000.000).
3. Set parameter 707 velocity feed forward to 100.
4. Start test-run with virtual master with a known velocity via input 3 = 1.
5. Increase parameter 707 while watching master and slave velocity (press [DISPLAY/STATUS] to get the velocity readouts). You have found the optimal velocity feed forward when slave velocity is approximately equal to the master velocity.
6. Stop test-run by input 3 = 0.
7. Reset parameter 719 to the original value.
8. Reset parameter 706 to 1000.

Second step is to optimise the PID controller, a good starting point can be found by means of the automatic calculation function:

By setting parameter 729 to "2" velocity feed forward calculation is activated as well as calculation of PID sample time and P/D factors, remember to make the required parameter settings according to the description of par. 729 before starting the calculation. The calculation is done when the value of par. 729 returns to "0".

Using the test run functions can optimise the PID factors further:

There are two types of test run available: Positioning where the slave drive moves a specific distance and Synchronizing with virtual master where the slave follows the virtual master in position or speed. Generally it is better to use test run with virtual master as that comes closer to the operating conditions in synchronizing mode (program 2).

For test run with positioning the following parameters must be set:

Parameter 725 Test run speed: Record the speed as a percentage of the maximum speed of parameter 716.

Parameter 726 Test run acceleration: record the acceleration time in per cent. 100% is minimum acceleration. 50% is half as fast as minimum acceleration, the ramp time will thus be twice as long.

Parameter 727 Test run distance: Record the distance (quad counts) for the drive to run during optimization.

Then use the following procedure:

1. Close the contacts at terminal 32 (clockwise direction) or terminal 33 (counter-clockwise). During the test the last value of the first display line will indicate the track error (PID error). After the test run is completed you can see the maximum track error (PID error).
2. Increase the P-portion (par. 702). After each change you should make a test run to find the right setting. If the drive becomes unsteady or if a message is given about over-voltage or over-current, then reduce the value in parameter 702 to about 70-80% of the set value.
3. Now set the D-portion (parameter 703) to 5 times the value of parameter 702.
4. If a lower synchronizing error is required the I-portion (parameter 704) can be set to a low value e.g. 10 but be careful a too high value will cause overshoot and instability

For test run with virtual master the following parameters must be set:

Parameter 748 Virtual master reference: Select the reference source for setting the velocity of the virtual master. "0" is analogue input 53, "1" is analogue input 60, "2" is parameter 216 and "3" is Field bus PCD 2.

Parameter 749 Virtual master acceleration: Set the acceleration of the virtual master in encoder pulses per second².

Parameter 750 Virtual master maximum speed: Set the maximum velocity of the virtual master in encoder pulses per second.

Then use the following procedure:

1. Start test run with virtual master by activating input 3. During test run you can read the track error in the last value of the first display line. At stop the maximum track error during the test run is read out.
2. If more accurate and dynamic control is required the P-portion (parameter 702) must be increased. If the slave becomes unstable the value must be reduced to by approximately 25%.
3. Now set the D-portion (parameter 703) to 5 times the value of parameter 702
4. If a lower synchronizing error is required the I-portion (parameter 704) can be set to a low value e.g. 10 but be careful a too high value will course overshoot and instability.

To store the optimized values:

Activate Input I4 (Store) or change first the value of parameter 710 to "1" .

How to program synchronization

Change the value of parameter 701 to "2". This will start the synchronization program of VLT 5000. To do the synchronization programming you use the following parameters:

- Parameter 725 Type of operation: Record "1" or "4" for position synchronization.
- Parameter 729 Home function: Specify the start function of the drive:
"0" no defined position
"1" Home run must be carried out before the first start of synchronization
"2" Home run must be carried out before each start of synchronization.
- Parameter 730 Home speed: Set the speed (% of maximum speed) at which Homing is to be made. Positive values for clockwise rotation, negative values for counter-clockwise rotation.
- Parameter 731 Home acceleration: Set the acceleration (% of minimum acceleration) for homing.
- Parameter 733 Accuracy: Record a value (quad counts) for a tolerance within which the slave position may deviate from the position of the master. With a negative value the synchronizing error (parameter 797) show the error with a sign.
- Parameter 734 Marker quantity Fault: Inaccuracy: Record the number of marker signals to generate a Fault signal.
- Parameter 735 Marker quantity Ready: Accuracy: Record the number of marker signals to generate a Ready signal.
- Parameter 737 Gear ratio No.: Record the number of the gear ratio that is to be displayed in Parameters 738 to 739. First set the number of the gear ratio, then the necessary values for this gear ratio can be set in Parameters 738 and 739. The next gear ratio is then selected in Parameter 737 and the same procedure is repeated.
- Parameter 738 Gear ratio numerator: Enter here the numerator value of the gear ratio. The value corresponds to the encoder pulses of the slave drive. To make fine adjustment possible by means of inputs 32 and 33 a ratio of for example 7:16 must be programmed as 7000:16000.

Parameter 739 Gear ratio denominator: Record the denominator value of the gear ratio. This value corresponds to the master pulses.

Parameter 742 Fixed Offset: Record a fixed position offset for the selected gear ratio (quad counts). You use this value to specify the position deviation between slave and master. During operation you can change the value by means of inputs 32 and 33.

Note: Offset is related to the master position. Offset related to the slave position can be calculated as follows:

$$\text{Offset_slave} = \frac{\text{Offset} * \text{Parameter738}}{\text{Parameter739}}$$

Parameter 743 Step time: Record the delay in ms from one frequency change to another (hold mode) and from one gear ratio numerator factor change to another (synchronization mode) when there is a signal on terminal 32 or 33.

Parameter 744 Step width: Record a value to specify the position displacement between slave and master.

Parameter 745 Slave speed factor: Record the factor by which the slave speed must be multiplied, so that the desired value is displayed. To calculate the value use the following formula:

$$\text{Factor} = \frac{N_{Set} * 400 * \text{Slaveencoder_resolution}}{60 * \text{Display_value}}$$

Example:

Resolution 1024 increments, desired display 100 at 1500¹/_{min}

$$\text{Factor} = \frac{1500 \frac{1}{\text{min}} * 400 * 1024 \frac{\text{Incr.}}{\text{Rev.}}}{60 * 100} = \underline{\underline{102400}}$$

Parameter 746 Master speed factor: Record the factor by which the master speed must be multiplied, so that the desired value is displayed. To calculate the value use the following formula:

$$\text{Factor} = \frac{N_{Set} * 400 * \text{Masterencoder_resolution}}{60 * \text{Display_value}}$$

Parameter 747 Synchronization error display factor: Record the factor by which the error must be multiplied, so that the desired value is displayed. To calculate the value use the following formula:

$$\text{Factor} = \frac{N_{Set} * 400 * \text{Slaveencoder_resolution}}{60 * \text{Display_value}}$$

Store your data settings by means of Store Input (I4) or by changing Parameter 710 to "1".

Operation and operating functions

After all values have been set as described and the controller has been optimized for the application, Parameter 729 Home function is set to the value of “2”. The drive can now be operated normally.

Home run

As parameter 729 is set to “2”, homing must be carried out before each start. To start homing the contact at Terminal 19 is closed. The slave drive then travels to the home switch and stops there. If the reversing procedure is set to “0”, the slave travels back to the start of the home switch; otherwise, the offset arising from disabling reversing is added to the fixed offset.

Starting synchronization

Preferably, the master is first similarly brought into its start position and the slave activated by means of I1 (SyncStart), then the master is started. This produces optimum synchronization. The slave can, of course, also be started by, e.g. a start signal from the master, although in that case it should be noted that the delay of the start signal can be prolonged by the scan time of e.g. the PLC. Attention should be paid to the accuracy of the start signal. Hence, it is better to start the slave drive when the master is in position. The position of the master, plus the value of the fixed offset, is the synchronization position to which the slave drive will travel at the maximum permitted acceleration when started. It may happen here that the slave drive travels faster than the master, as the slave drive needs to catch up with the master position.

Stopping synchronization

On opening the SyncStart contact (I1), the slave is stopped at the permitted acceleration. Because Home function is set at “2”, a new start is only possible after a renewed Home run.

Fine setting of the position

As soon as the slave drive is in position synchronization to the master, a displacement of this position can be effected by means of Inputs 32 + 33. These settings are only temporary, i.e. the fine-setting data are lost as soon as the converter is disconnected from the mains. If the displacement data are to be retained, they must be stored by activating save Input (I4) or by means of Parameter 710 before switching off.

Offset is related to the master position. Offset related to the slave position can be calculated as follows:

$$\text{Offset_slave} = \frac{\text{Offset} * \text{Parameter738}}{\text{Parameter739}}$$

Switching to another gear ratio

During synchronization, a new gear ratio can be selected at Inputs 16 and 17. The gear ratio is then activated by means of the Switching Input (I2). The slave will then proceed at the permitted acceleration to this new gear ratio. The offset is related to the first gear ratio after SyncStart. Therefore a stop and then start must be performed if the offset must relate to the latest gear ratio if the gear ratio has been changed.

Error procedure

Errors of tracking, over current etc. make the drive stop. The Ready output (O8) is set low.

Reset is done with Input 27 or fieldbus bit 1.9.

Reset is also possible with of the local control panel of the drive. This is only possible if the local stop function is the [STOP/RESET] key disabled in parameter 014.

Note: You cannot stop the drive via the local control panel if local stop is disabled.

In case the drive has stopped because of earth fault or short-circuit, disconnect the drive from the mains before you reset!

Marker synchronizing

Using Marker synchronizing you do not predefine the start position. The Marker will alter the position during operation, as required.

Marker synchronizing is for example used to compensate for any undesired slip.

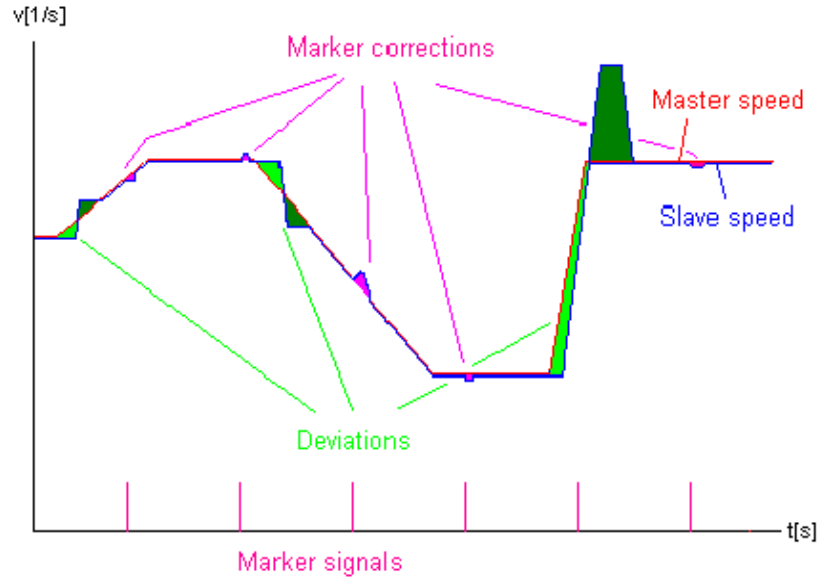

Figure 21: Control behavior with marker synchronization

It appears from the diagram that the control accuracy depends on the master acceleration and on the speed deviation between slave and master.

The following example shows the use of marker synchronization to compensate for friction slip that can arise from dropping a box onto Conveyor belt 1. By means of marker correction in the form of object recognition, the slave belt is controlled so that the product will always be placed right in the middle of the box, even if the box itself is not centrally positioned in its conveyor compartment.

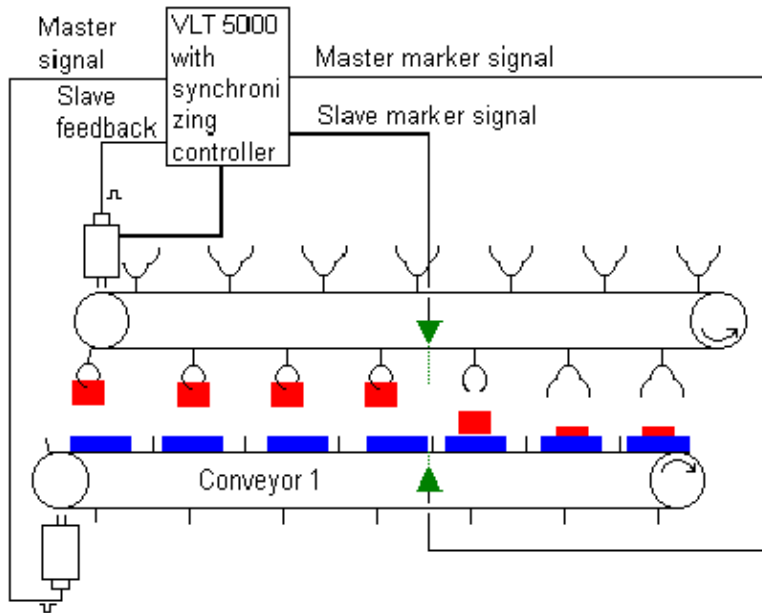

Figure 22: Conveyor belt with marker synchronization

Function diagrams for marker synchronization

SyncStart to a running master after Power ON

If the slave is synchronized to a running master drive, the slave automatically synchronizes its position to the master. After at least one slave marker and one master marker have been detected, the marker compensation comes into effect.

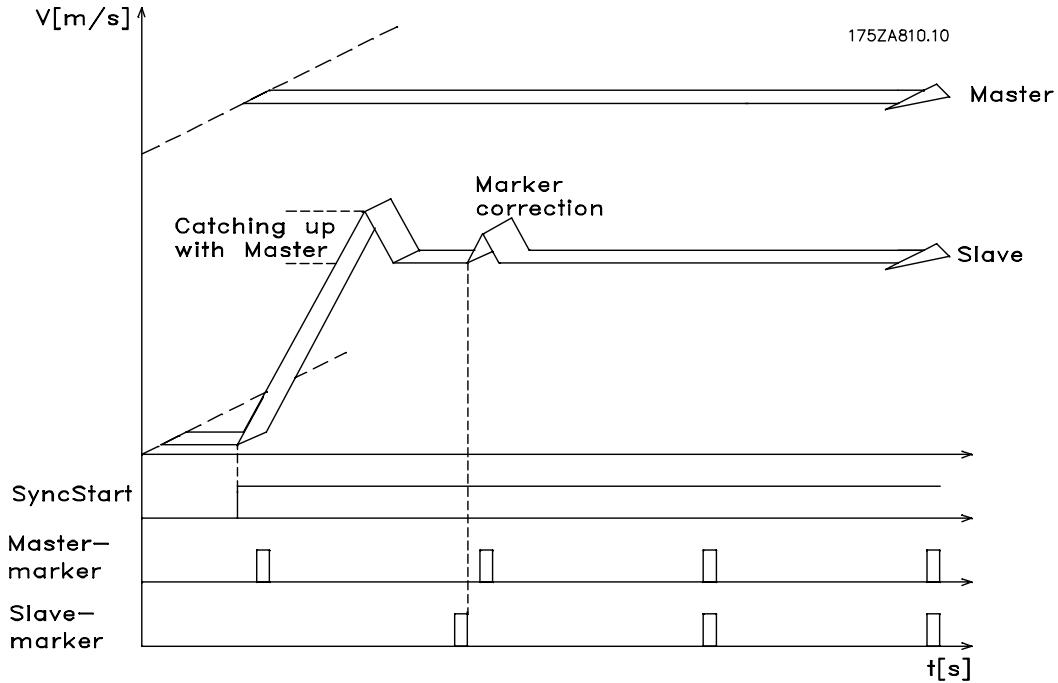

Figure 23: Initial start-up with marker synchronization

Marker correction during operation

During operation, marker correction is always carried out when the markers is detected. This ensures optimum synchronization, no matter whether the gear ratios are not accurate or there is a slip.

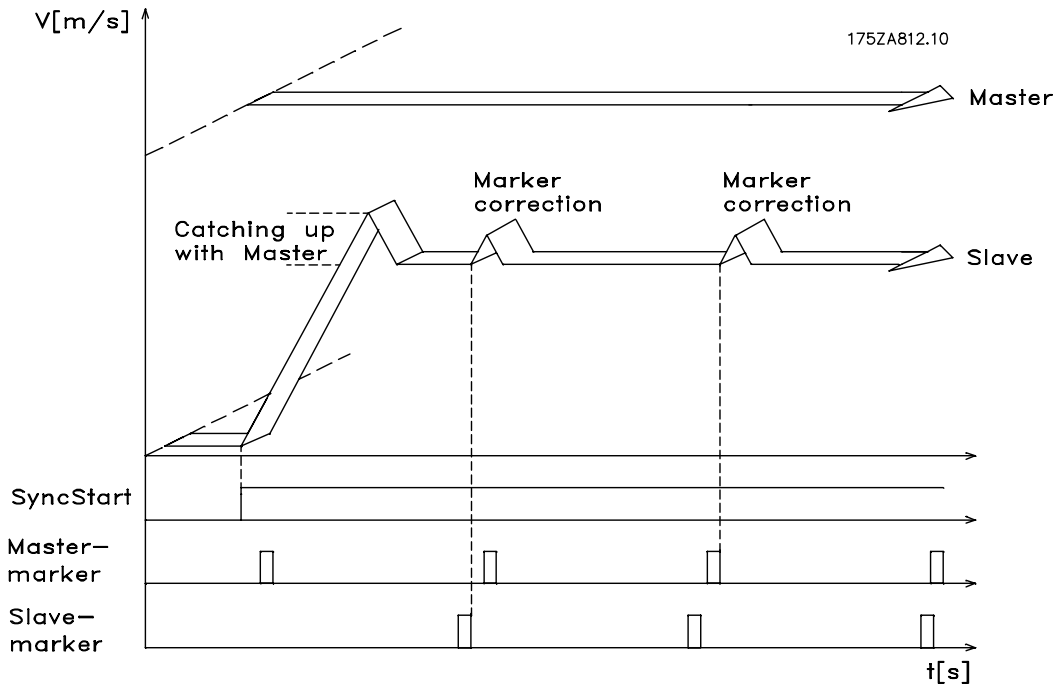

Figure 24: Marker correction during operation

Application example - Packaging

This example is a conveyor belt with cardboard boxes of low weight and different lengths. To ensure that the components to be packed are placed right in the middle of the boxes you must use synchronization with marker correction. The grab belt is controlled by position synchronization and as soon as one of the two markers is recognized, the grab belt is either moved forward to the conveyor belt position or slowed down. It is also possible for the operator to change the position by means of two pushbuttons.

Terminals and terminal configuration

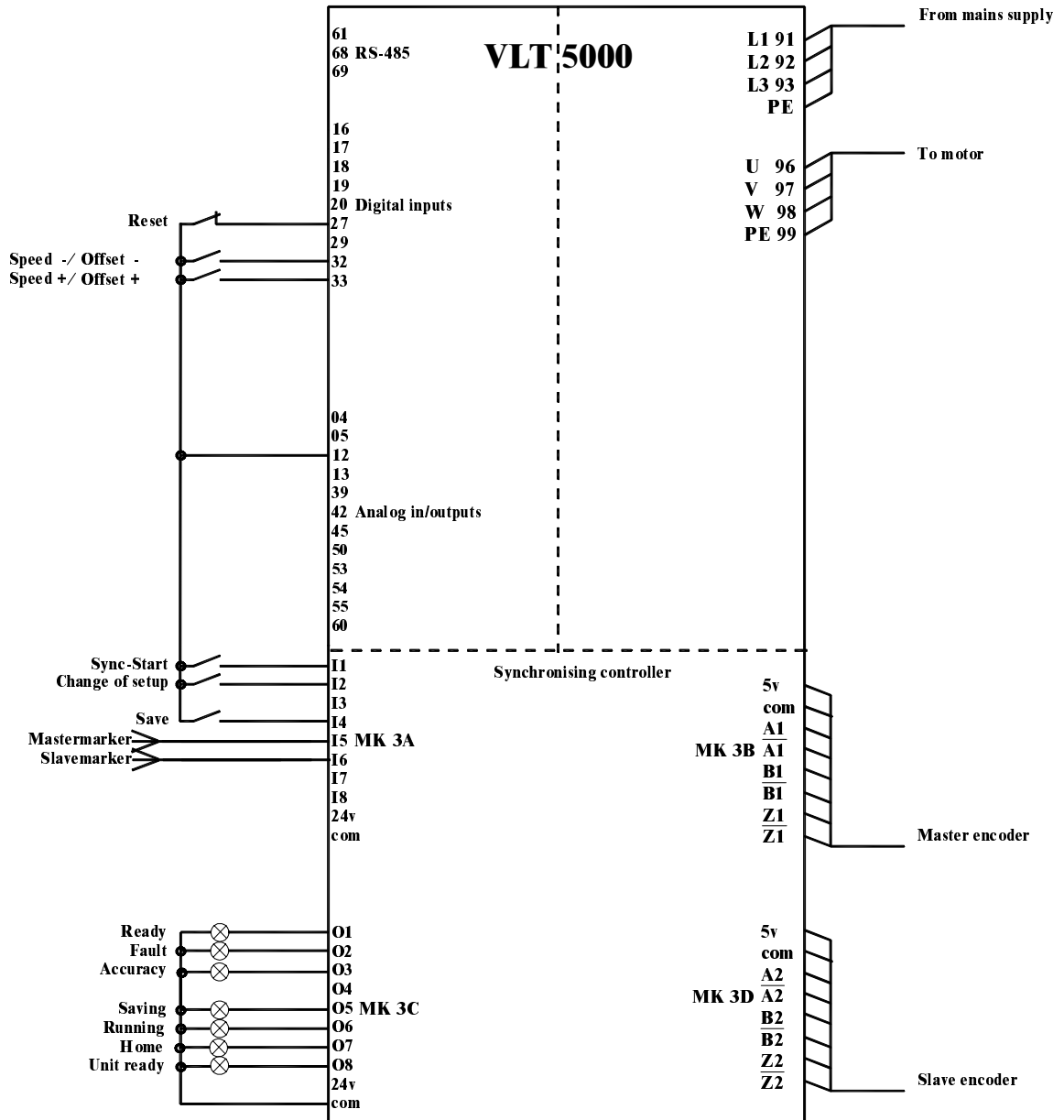

Figure 26: Wiring diagram - conveyor belt regulation

Setting the parameters

For this we recommend to have the description of parameters at hand. **See the VLT 5000/VLT5000Flux Operating Instructions.**

NOTE: It is very important that the VLT is optimized for the motor before optimizing the Synchronizing controller. First you record the motor data and perform an AMA (Automatic Motor Adaptation) if possible and then you can start programming your synchronization functions

Parameter 205 Maximum reference: Set the frequency for a value that is about 10% higher than the maximum value of parameter 716.

Example:

Motor 7.5kW, 1460 $\frac{1}{\text{min}}$ at 50Hz, speed of the application approx. 1800 $\frac{1}{\text{min}}$

$$\frac{f_{Nom} * N_{Application}}{N_{Nom}} * 1,1 = \frac{50\text{Hz} * 1800 \frac{1}{\text{min}}}{1460 \frac{1}{\text{min}}} * 1,1 = \underline{\underline{62\text{Hz maximum ref. value}}}$$

Parameter 701 Record "1" to start the test program.

Parameter 709 When performing position synchronization this parameter is used to insert a filter to compensate for an oscillating master signal. If, for example, the master is experiencing shock loads the pid loop of the synchronizing controller will have a tendency to oscillate as well. A negative value must be entered.

Example:

If a filter factor of -100000 (100 ms) is used the correction is balanced within: $1000/(\text{filter factor} * 10) = 1 \text{ second.}$

Parameter 711 Record the slave encoder type. "0" represents an incremental encoder.

Parameter 712 Record the resolution of the slave encoder.

Parameter 713 Record the master encoder type. "0" represents an incremental encoder.

Parameter 714 Record the resolution of the master encoder.

Parameter 715 Direction of rotation: Record "1" for clockwise rotation of the slave. Record "-1" if the slave is to run in the opposite direction.

Parameter 716 Record maximum RPM measured at the slave encoder.

Parameter 717 Minimum ramp: Set the time in ms for the slave drive to accelerate from standstill to maximum speed (par. 716). Consider the value carefully as this setting will highly affect the control accuracy!

Parameter 718 Ramp type: Record "0" for linear ramp and "1" for s-ramp. NOTE: S-ramp requires higher acceleration torque.

Parameter 719 Maximum track error: Record the value that is to generate "Track error" indication in the display, if exceeded.

Parameter 720 Reversing procedure: Record "0" if reversing is allowed, "1" if the slave must always follow the direction of the master or "2" if reversing is not allowed.

- Parameter 721 Slave marker type: As external marker signals are used, you can set the type of edge triggering of the external marker signal; “2” for a positive edge, “3” for a negative edge.
- Parameter 722 Slave marker interval: Record the interval between two marker signals of the slave. Input of the interval is in quad counts. If the interval is not known, it can also be determined during the test run.
- Parameter 723 Master marker type: As external marker signals are used, you can set the type of edge triggering of the external marker signal here; “2” for a positive edge, “3” for a negative edge.
- Parameter 724 Master marker interval: Record the interval between two marker signals of the master. Input of the interval is in quad counts. If the interval is not known, it can also be determined during the test run.
- Parameter 725 Test run speed: Record the speed at which you want to carry out the optimization run. Record the speed as a percentage of the speed in Parameter 716.
- Parameter 726 Test run acceleration: Record the acceleration for the test run in percent of the minimum acceleration time. 100% represents the minimum acceleration, 50% is half as fast as minimum acceleration; the ramp time is thus twice as long.
- Parameter 727 Test run distance: Record the distance (quad counts) for the drive to travel during optimization.

How to check the motor connection

When you have programmed the above parameters you check the motor connection as follows:

1. Remove all signals to terminals 16-33 and I1-I8). Only input 27 must be connected and closed.
2. Select “Local” function in parameter 002. – VLT 5000 stops (display flashing)
3. Set the frequency for a low value, for example 3 Hz in parameter 003.
4. Press the [START] button on the VLT 5000 control panel and then the [STOP/Reset] button watching the direction of the motor. If the motor rotates in the wrong direction then exchange the motor phases.

How to test the incremental encoders

When you have tested the motor speed direction you test the incremental encoder connection as follows:

1. Remove all signals to terminals 16-33 and I1-I8. Only input 27 must be connected and closed
2. Press the [DISPLAY/STATUS] button on the VLT 5000 control panel. Now the following values appear in the upper line of the display: slave position, master position and track error.
3. Rotate the slave drive motor shaft manually in the allowed direction. Now the display shows an ascending count of the slave position. If the count is descending, exchange the slave encoder track A by B and A/ by B/. If there is no counting in the display then check the wiring of the encoder.

Follow the same procedure when you test the master encoder. Note: To be right the count must be ascending here.

Remember to change parameter 002 back to “Remote” and start VLT 5000 by pressing the [START] button on the control panel.

How to optimize the controller

Synchronization is obtained via two main elements of the controller: Velocity feed forward and the PID controller.

NOTE: Before starting the optimizing procedures it is important to select the right type of synchronization in parameter 728, in this example it must be “1” for position synchronization. Please always have the necessary degree of accuracy in mind, you could go on optimizing for a long time, but it might not be necessary to have a 100% accuracy in the application you are dealing with.

First step is to optimize velocity feed forward this can be done via the automatic calculation function:

Velocity feed forward calculation is activated by setting parameter 729 to “1”, remember to make the required parameter settings according to the description of par. 729 before starting the calculation. The calculation is done when the value of par. 729 returns to “0”.

Velocity feed forward can also be optimized manually by the following procedure:

9. Set parameter 706 PID bandwidth to “0”.
10. Set parameter 719 maximum track error to a high value (e.g. 1.000.000).
11. Set parameter 707 velocity feed forward to 100.
12. Start test-run with virtual master with a known velocity via input 3 = 1.
13. Increase parameter 707 while watching master and slave velocity (press [DISPLAY/STATUS] to get the velocity readouts). You have found the optimal velocity feed forward when slave velocity is approximately equal to the master velocity.
14. Stop test-run by input 3 = 0.
15. Reset parameter 719 to the original value.
16. Reset parameter 706 to 1000.

Second step is to optimise the PID controller, a good starting point can be found by means of the automatic calculation function:

By setting parameter 729 to “2” velocity feed forward calculation is activated as well as calculation of PID sample time and P/D factors, remember to make the required parameter settings according to the description of par. 729 before starting the calculation. The calculation is done when the value of par. 729 returns to “0”.

Using the test run functions can optimise the PID factors further:

There are two types of test run available: Positioning where the slave drive moves a specific distance and Synchronizing with virtual master where the slave follows the virtual master in position or speed. Generally it is better to use test run with virtual master as that comes closer to the operating conditions in synchronizing mode (program 2).

For test run with positioning the following parameters must be set:

Parameter 725 Test run speed: Record the speed as a percentage of the maximum speed of parameter 716.

Parameter 726 Test run acceleration: record the acceleration time in per cent. 100% is minimum acceleration. 50% is half as fast as minimum acceleration, the ramp time will thus be twice as long.

Parameter 727 Test run distance: Record the distance (quad counts) for the drive to run during optimization.

Then use the following procedure:

5. Close the contacts at terminal 32 (clockwise direction) or terminal 33 (counter-clockwise). During the test the last value of the first display line will indicate the track error (PID error). After the test run is completed you can see the maximum track error (PID error).
6. Increase the P-portion (par. 702). After each change you should make a test run to find the right setting. If the drive becomes unsteady or if a message is given about over-voltage or over-current, then reduce the value in parameter 702 to about 70-80% of the set value.
7. Now set the D-portion (parameter 703) to 5 times the value of parameter 702.
8. If a lower synchronizing error is required the I-portion (parameter 704) can be set to a low value e.g. 10 but be careful a too high value will course overshoot and instability

For test run with virtual master the following parameters must be set:

Parameter 748 Virtual master reference: Select the reference source for setting the velocity of the virtual master. "0" is analogue input 53, "1" is analogue input 60, "2" is parameter 216 and "3" is Field bus PCD 2.

Parameter 749 Virtual master acceleration: Set the acceleration of the virtual master in encoder pulses per second².

Parameter 750 Virtual master maximum speed: Set the maximum velocity of the virtual master in encoder pulses per second.

Then use the following procedure:

1. Start test run with virtual master by activating input 3. During test run you can read the track error in the last value of the first display line. At stop the maximum track error during the test run is read out. Because velocity synchronization is selected (parameter 728 = 0) the track error is velocity deviance between master and slave.
2. If more accurate and dynamic control is required the P-portion (parameter 702) must be increased. If the slave becomes unstable the value must be reduced to by approximately 25%.
3. Now set the D-portion (parameter 703) to 5 times the value of parameter 702
4. If a lower synchronizing error is required the I-portion (parameter 704) can be set to a low value e.g. 10 but be careful a too high value will course overshoot and instability.

If the interval between two marker signals at the slave is not known, this interval can now be measured. To do this, the contact at the Slave marker search input (I8) is closed. The slave drive now rotates at the set test run speed. With each master signal, the interval can be read off in Parameter 722. If the marker search is stopped by opening the Slave marker search contact (I8), an average of all the marker intervals is taken, and this is entered as the value in Parameter 722. Similarly, the intervals between the marker signals of the master drive are measured by means of the Master marker search input (I7). To do this, it is necessary to start the master. The intervals are continuously displayed in Parameter 724. After opening the Master marker search contact (I7), the calculated average of all the measurements is again entered as the final result in Parameter 724.

After the drive has been optimized, the data found are stored by activating Input I4 (Store), or by changing Parameter 710 to "1".

How to program synchronization

Change the value of parameter 701 to "2". This will start the synchronization program of VLT 5000. To do the synchronization programming you use the following parameters:

- Parameter 725 Type of operation: Record "2" or "5" for marker synchronization.
- Parameter 732 Marker synchronization behaviour: Specify here how the slave drive is to react while synchronizing to the master marker. "0" means the last marker pulse of the master - the slave synchronizes to the last master marker pulse already registered - it catches up. "1" means the next master marker pulse - the slave waits for the next master marker and synchronizes to it - the slave slows down. "2" means that the slave uses the nearest master marker - it decides for itself whether to catch up or slow down.
- Parameter 733 Accuracy: Record a value (quadcounts) for a tolerance within which the slave position may deviate from the position of the master.
- Parameter 734 Marker quantity Fault: Inaccuracy: Record the number of marker signals to generate a Fault signal.
- Parameter 735 Marker quantity Ready: Accuracy: Record the number of marker signals to generate a Ready signal.
- Parameter 737 Gear ratio No.: Record the number of the gear ratio that is to be displayed in Parameters 738 to 742. First set the number of the gear ratio, then in Parameters 738 to 742 the necessary values for this gear ratio. The next gear ratio is then selected in Parameter 737 and the same procedure is repeated.
- Parameter 738 Gear ratio numerator: Record the numerator value for the gear ratio. That is the encoder pulses of the slave drive. To make fine adjustment possible by means of inputs 32 and 33 a ratio of for example 7:16 must be programmed as 7000:16000.
- Parameter 739 Gear ratio denominator: Record the denominator value of the gear ratio. This value corresponds to the master pulses.
- Parameter 740 Slave markers: Record the number of slave markers for the marker ratio. Ensure that the gear ratio and the marker ratio match each other.
- Parameter 741 Master markers: Record the number of master markers for the marker ratio. Ensure that the gear ratio and the marker ratio match each other.
- Parameter 742 Fixed Offset: Record a fixed position offset for the selected gear ratio (quad counts). This value specifies the position deviation between the slave marker and the master marker. During operation the offset can be changed by means of inputs 32 and 33.
Note: Offset is related to the master position. Offset related to the slave position can be calculated as follows:
- $$\text{Offset_slave} = \frac{\text{Offset} * \text{Parameter 738}}{\text{Parameter 739}}$$
- Parameter 743 Step time: Record the delay in ms from one frequency change to another (hold mode) and from one gear ratio numerator factor change to another (synchronization mode) when there is a signal on terminal 32 or 33.

Parameter 744 Step width: In marker synchronization mode, Offset Parameter 740 is changed by this value when Terminal 32 or Terminal 33 is activated.

Parameter 745 Slave speed factor: Record the factor by which the slave speed must be multiplied, so that the desired value is displayed. To calculate the value use the following formula:

$$\text{Factor} = \frac{N_{Set} * 400 * \text{Slaveencoder_resolution}}{60 * \text{Display_value}}$$

Example:

resolution 1024 increments, desired display 100 at 1500¹/_{min}

$$\text{Factor} = \frac{1500 \frac{1}{\text{min}} * 400 * 1024 \frac{\text{Inkr.}}{\text{Umdr.}}}{60 * 100} = \underline{\underline{102400}}$$

Parameter 746 Master speed factor: Record the factor by which the master speed must be multiplied, so that the desired value is displayed. To calculate the value use the following formula:

$$\text{Factor} = \frac{N_{Set} * 400 * \text{Masterencoder_resolution}}{60 * \text{Display_value}}$$

Parameter 747 Synchronizing error display factor: Record the factor by which the error must be multiplied, so that the desired value is displayed. To calculate the value, use the following formula:

$$\text{Factor} = \frac{N_{Set} * 400 * \text{Slaveencoder_resolution}}{60 * \text{Display_value}}$$

Store your data settings by means of Store Input (I4) or by changing Parameter 710 to "1".

Operation and operating functions

After all the values have been set as described, the drive can now be operated normally.

Starting synchronization

Synchronization of the slave is started by means of SyncStart (I1), then the master is started. This ensures optimum synchronization. The slave drive travels in position synchronization to the master until both slave and master marker has been detected. The slave accelerates or slows down, according to the setting of Parameter 732, in order to attain the marker position plus the set offset. It may happen that the slave drive travels faster than the master does, if the slave drive needs to catch up with the position.

Stopping synchronization

On opening contact I1 (SyncStart), the slave is stopped at the permitted acceleration.

Fine setting of the position

As soon as the slave drive is in position synchronization to the master, an adjustment of this position can be made by means of Inputs 32 + 33. This setting is only temporary, i.e. the fine-setting data are lost as soon as the converter is disconnected from the mains. If the adjustment data are to be retained, storage must be carried out by activating the Save Input (I4) or by means of Parameter 710 before switching off the drive.

Note: Offset is related to the master position. Offset related to the slave position can be calculated as follows:

$$\text{Offset_slave} = \frac{\text{Offset} * \text{Parameter738}}{\text{Parameter739}}$$

Switching to another gear ratio

During synchronization, a new gear ratio can be selected at Inputs 16 and 17. The gear ratio is then activated by means of the Switching Input (I2). The slave will then proceed at the permitted acceleration to this new gear ratio. The offset is related to the first gear ratio after SyncStart. Therefore a stop and then start must be performed if the offset must relate to the latest gear ratio if the gear ratio has been changed.

Error procedure

Errors of tracking, over current etc. make the drive stop and the Ready output (O8) is set low.

Reset is done with Input 27 or fieldbus bit 1.9.

Reset is also possible with the [STOP/RESET] key of the local control panel of the drive. This is only possible if the local stop function is disabled in parameter 014.

Note: You cannot stop the drive via the local control panel if local stop is disabled.

In case the drive has stopped because of earth fault or short-circuit, disconnect the drive from the mains before you reset!

Appendix

Messages and error reference

All messages are shown in abbreviated form in the VLT LCP display.

You can find brief information on the error messages in the table or detailed information in the section following the table.

Table of error messages

The table contains the error messages in numerical order.

O.ERR	LCP DISPLAY
5	ERROR NOT CLEARED
8	POSITION ERROR
9	INDEX NOT FOUND
13	VLT NOT READY
16	PARAM. ERROR EEPROM
17	PROGR. ERROR EEPROM
18	RESET BY CPU
92	ENCODER ERROR
xx	INTERNAL ERROR

Error messages in detail

As in the table above, the messages are in numerical order: here you will find additional notes on possible causes of errors as well as tips for clearing errors.

O.ERR_5

Error not cleared

Cause

An attempt was made to execute a command to move, although an existing error message had not been erased.

O.ERR_8

Position error

Meaning

The interval between the reference position and the feedback position was greater than defined in Tolerated Position Error Parameter.

Causes

Mechanically blocked or overloaded drive, tolerated position error too small, reference speed greater than VLT Parameters 202 and 205, reference acceleration too great, Proportional factor too low or VLT not released.

O.ERR_9

Index pulse (encoder) not found

Meaning

During a reference or index search, the encoder index pulse could not be found within one encoder rotation.

Causes

A encoder without an index pulse is being used, the index pulse is not correctly connected, incorrect index pulse, or the encoder resolution has been set too low.

O.ERR_13

VLT NOT READY

Cause

VLT is not ready but the PID controller is active. The VLT status word (Bit 09 and bit 11) is monitored every 20msec when the PID controller is active. The VLT is in the "Not ready" state when:

- it has an alarm,
- it is in local mode (parameter 002 = local),
- local LCP stop is activated,

O.ERR 13 can be reset by toggling input 27.

Note

When pressing local stop on the LCP error 13 may show on the display. To avoid this you can set parameter 014 to "disable" but that will disable the stop function of the local control panel.

O.ERR_16

Parameters in EEPROM are corrupted

Meaning

The parameter set recorded in the memory is no longer correctly available.

Causes

Defective EEPROM or power failure during the parameter save procedure.

Note

You must re-initialise the parameters by following the initialising procedure on page 35. If this does not cure the problem the option card must be replaced.

O.ERR_17

Programs in EEPROM are corrupted

Meaning

The program data recorded in the memory are no longer available or no longer correct.

Causes

Defective EEPROM

Note

Replace the option card.

O.ERR_18

Reset by CPU

Meaning

The processor was stopped. This, in turn, was detected by an internal monitoring circuit (Watch dog) and automatically triggered a reset.

Causes

Temporary voltage drop, voltage peak or short-circuit.

O.ERR_92

Encoder error

Meaning

There is a short or open circuit on one of the encoder inputs.

Causes

A defective encoder or a problem with the encoder cable.

O.ERR xx

Internal error ##

Meaning

If an error like this appears, please perform a power cycle, if the problem persists the option card must be replaced.

Parameter overview

Parameter number	Description
702	P-portion Factory setting: 10 Setting range from: 0 to: 65000 User setting: _____
703	D-portion Factory setting: 0 Setting range from: 0 to: 65000 User setting: _____
704	I-portion. Factory setting: 0 Setting range from: 0 to: 65000 User setting: _____
705	Limitation for I-portion Factory setting: 1000 Setting range from: 0 to: 65000 User setting: _____
706	Band width PID controller Factory setting: 1000 Setting range from: 0 to: 65000 User setting: _____
707	Velocity feed forward Factory setting: 0 Setting range from: 0 to: 65000 User setting: _____
708	Acceleration feed forward Factory setting: 0 Setting range from: 0 to: 65000 User setting: _____
709	Velocity filter Factory setting: 0 Setting range from: 0 to: 65000 User setting: _____
710	Store data Factory setting: 0 Setting range from: 0 to: 1 User setting: _____

711	<p>Slave encoder type Factory setting: 0 Setting range from: 0 to: 102 User setting: _____</p>
712	<p>Slave encoder resolution Factory setting: 1024 increments Setting range from: 1 to: 2147483647 increments User setting: _____ increments</p>
713	<p>Master encoder type Factory setting: 0 Setting range from: 0 to: 102 User setting: _____</p>
714	<p>Master encoder resolution Factory setting: 1024 increments Setting range from: 1 to: 2147483647 increments User setting: _____ increments</p>
715	<p>Direction of rotation Factory setting: 1 Setting range from: -2 to: 2 User setting: _____</p>
716	<p>Maximum speed Factory setting: 1500 ¹/_{min} Setting range from: 1 to: 65535 ¹/_{min} User setting: _____ ¹/_{min}</p>
717	<p>Minimum ramp Factory setting: 100 ms Setting range from: 50 to: 2147483647 ms User setting: _____ ms</p>
718	<p>Ramp type Factory setting: 0 Setting range from: 0 to: 1 User setting: _____</p>
719	<p>Maximum track error Factory setting: 10000 quad counts Setting range from: 1 to: 2147483647 quad counts User setting: _____ quad counts</p>
720	<p>Reversing behavior Factory setting: 0 Setting range from: 0 to: 2</p>

	User setting: _____
721	Slave marker type Factory setting: 0 Setting range from: 0 to: 3 User setting: _____
722	Marker interval at the slave Factory setting: 4096 quad counts Setting range from: 0 to: 2147483647 quad counts User setting: _____ quad counts
723	Master marker type Factory setting: 0 Setting range from: 0 to: 3 User setting: _____
724	Marker interval at the master Factory setting: 4096 quad counts Setting range from: 0 to: 2147483647 quad counts User setting: _____ quad counts
725	<i>Test run; Program 1:</i> Test run speed Factory setting: 10 % Setting range from: 1 to: 100 % User setting: _____ % <i>Synchronous operation; Program 2:</i> Type of operation Factory setting: 0 Setting range from: 0 to: 7 User setting: _____
726	<i>Test run; Program 1:</i> Test run acceleration Factory setting: 10 % Setting range from: 1 to: 200 % User setting: _____ % <i>Synchronous operation; Program 2:</i> Hold function Factory setting: 0 Setting range from: 0 to: 1 User setting: _____
727	<i>Test run; Program 1:</i> Test run distance Factory setting: 4096 quad counts Setting range from: 1 to: 2147483647 quad counts

	<p>User setting: _____ quad counts</p> <p><i>Synchronous operation; Program 2:</i></p> <p>Hold speed Factory setting: 10% Setting range from: 0 to: 100 %</p> <p>User setting: _____ %</p>
728	<p><i>Test run, program 1:</i></p> <p>Synchronizing type (Sync type) Factory setting: 0 Setting range from: 0 to: 1</p> <p>User setting: _____</p> <p><i>Synchronous operation; Program 2:</i></p> <p>Delta hold speed Factory setting: 5 % Setting range from: 1 to: 100%</p> <p>User setting: _____ %</p>
729	<p><i>Test run, program 1:</i></p> <p>Activate feed forward and PID calculation (FFVEL calc.). Factory setting: 0 Setting range from: 0 to: 2</p> <p>User setting: _____</p> <p><i>Synchronous operation; Program 2:</i></p> <p>Home function Factory setting: 0 Setting range from: 0 to: 2</p> <p>User setting: _____</p>
730	<p><i>Test run, program 1:</i></p> <p>Encoder velocity (Encoder RPM). Factory setting: 1500 Setting range from: 1 to: 65000 RPM</p> <p>User setting: _____ RPM</p> <p><i>Synchronous operation; Program 2:</i></p> <p>Home speed Factory setting: 10 % Setting range from: 1 to: 100 %</p> <p>User setting: _____ %</p>
731	<p>Home acceleration Factory setting: 10 % Setting range from: 1 to: 200 %</p> <p>User setting: _____ %</p>

732	Marker synchronizing mode Factory setting: 0 Setting range from: 0 to: 1005 User setting: _____
733	Accuracy Factory setting: 1000 quad counts Setting range from: - 2147483647 to: 2147483647 quad counts User setting: _____ quad counts
734	Marker quantity FAULT Factory setting: 5 markers Setting range from: 1 to: 10000 markers User setting: _____ markers
735	Marker quantity READY Factory setting: 10 markers Setting range from: 1 to: 10000 markers User setting: _____ markers
736	M-S tolerance speed Factory setting: 0 % Setting range from: 0 to: 100 % User setting: _____ %
737	Gear ratio no. Factory setting: 0 Setting range from: 0 to: 3
738	Gear ratio numerator Factory setting: 1000 Setting range from: 1 to: 2147483647
739	Gear ratio denominator Factory setting: 1000 Setting range from: 1 to: 2147483647
740	Slave marker quantity Factory setting: 1 Setting range from: 1 to: 2147483647
741	Master marker quantity Factory setting: 1 Setting range from: 1 to: 2147483647

742	Fixed offset				
	Factory setting: 0 Setting range from: -2147483647 to: 2147483647				
737	Gear ratio no.	0	1	2	3
738	Numerator				
739	Denominator				
740	Slave markers				
741	Master markers				
742	Fixed offset				
743	Step time				
	Factory setting: 100 ms Setting range from: 10 to: 2147483647 ms User setting: _____ ms				
744	Step width				
	Factory setting: 1 Setting range from: -2147483647 to: 2147483647 User setting: _____				
745	Slave speed factor				
	Factory setting: 400 Setting range from: 1 to: 2147483647 User setting: _____				
746	Master speed factor				
	Factory setting: 400 Setting range from: 1 to: 2147483647 User setting: _____				
747	Synchronizing error display factor				
	Factory setting: 400 Setting range from: to: 2147483647 User setting: _____				
748	Virtual master reference value				
	Factory setting: 0 Setting range from: 0 to: 3 User setting: _____				
749	Virtual master acceleration				
	Factory setting: 25600 Hz/s Setting range from: 1 to: 2147483647 Hz/s User setting: _____ Hz/s				

750	Virtual master maximum speed Factory setting: 25600 $\frac{1}{s}$ Setting range from: 1 to: 2147483647 $\frac{1}{s}$ User setting: _____ $\frac{1}{s}$
751	Marker window slave Factory setting: 0 Setting range from: 1 to: 2147483647 User setting: _____
752	Marker window master Factory setting: 0 Setting range from: 1 to: 2147483647 User setting: _____
753	Control source test run (Contr. testrun). Factory setting: 0 Setting range from: 0 to 1 User setting: _____
754	Control source synchronizing (Contr. synchron). Factory setting: 0 Setting range from: 0 to 1 User setting: _____
755	Brake on delay (Brake on delay). Factory setting: 0 Setting range from: 0 to 5000msec. User setting: _____ msec
756	Brake off delay (Brake off delay). Factory setting: 0 Setting range from: 0 to 5000msec. User setting: _____ msec
775	<i>Synchronous operation, program 2:</i> Track error (read only).
776	Input status (read only). <i>Digital control (par. 753 and par. 754):</i> This parameter is showing the actual status of the 8 digital inputs (I1 - I8) on MK3A as a binary code. <i>Field bus control (par. 753 and par. 754):</i> This parameter is showing the status of the field bus control word (PCD 1) as a decimal value.

777	<p>PID-sample time Factory setting: 1 ms Setting range: 1 – 1000 ms User setting: _____ms</p>																											
778	<p><i>The following are display parameters only (read only)</i></p> <p>Status of Synchronization The following status flags are defined for position and marker synchronization. The flags are not updated when using speed synchronization:</p> <table border="0"> <thead> <tr> <th style="text-align: left;">Flag:</th> <th style="text-align: left;">Decimal value</th> <th style="text-align: left;">Bit</th> </tr> </thead> <tbody> <tr> <td>SYNCREADY</td> <td>1</td> <td>0</td> </tr> <tr> <td>SYNCFULT</td> <td>2</td> <td>1</td> </tr> <tr> <td>SYNCACCURACY</td> <td>4</td> <td>2</td> </tr> <tr> <td colspan="3"><i>Only marker Synchronization:</i></td> </tr> <tr> <td>Master marker HIT</td> <td>8</td> <td>3</td> </tr> <tr> <td>Slave marker HIT</td> <td>16</td> <td>4</td> </tr> <tr> <td>Master marker Error</td> <td>32</td> <td>5</td> </tr> <tr> <td>Slave marker Error</td> <td>64</td> <td>6</td> </tr> </tbody> </table> <p>The flags are reset when restarting synchronization (SyncStart).</p>	Flag:	Decimal value	Bit	SYNCREADY	1	0	SYNCFULT	2	1	SYNCACCURACY	4	2	<i>Only marker Synchronization:</i>			Master marker HIT	8	3	Slave marker HIT	16	4	Master marker Error	32	5	Slave marker Error	64	6
Flag:	Decimal value	Bit																										
SYNCREADY	1	0																										
SYNCFULT	2	1																										
SYNCACCURACY	4	2																										
<i>Only marker Synchronization:</i>																												
Master marker HIT	8	3																										
Slave marker HIT	16	4																										
Master marker Error	32	5																										
Slave marker Error	64	6																										
779	<p>Software version number. This is the software version number of your synchronizing controller</p>																											
795	<p>„Slave position“. The slave position is displayed in quad counts.</p>																											
796	<p>„Master position“. The master position is displayed in quad counts.</p>																											
797	<p><i>Test run; Program 1:</i></p> <p>„Track error“. The track error is displayed in quad counts.</p> <p><i>Synchronous operation; Program 2:</i></p> <p>„Sync-error“, The synchronization error is displayed with the value calculated in Parameter 747.</p>																											
798	<p>„Slave speed“. The slave speed is displayed with the value calculated in Parameter 745.</p>																											
799	<p>„Master speed“, The master speed is displayed with the value calculated in Parameter 746.</p>																											

Glossary of key terms

Master-Slave - It means that a signal is taken from a master drive. The signal is then used to control a second, "slave" drive that follows the master. The master drive does not have to be a drive; it can be any given part of a power transmission system.

Incremental encoder - This is an encoder system that picks up the speed and the direction of rotation and transmits on the appropriate configuration. The number of tracks, and thus the number of signals, indicates the properties of the encoder system. There are single-track systems that deliver a pulse signal dependent on the speed as well as a fixed direction signal. Dual-track systems deliver two pulse signals that are offset 90 degrees. By evaluating the two tracks, the direction signal is also obtained. Three-track encoders deliver, as well as the two tracks of the dual-track encoder, an additional "zero-track". This emits a signal when the zero transit is passed through.

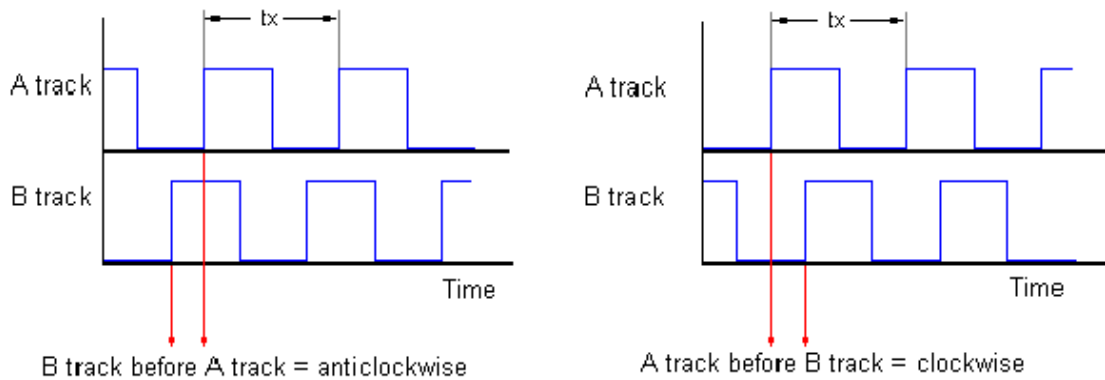

Figure 27: Incremental encoder signals

Quadcounts - Through edge detection, a quadrupling of the increments is produced by both tracks (A/B) of the incremental encoder. This improves the resolution.

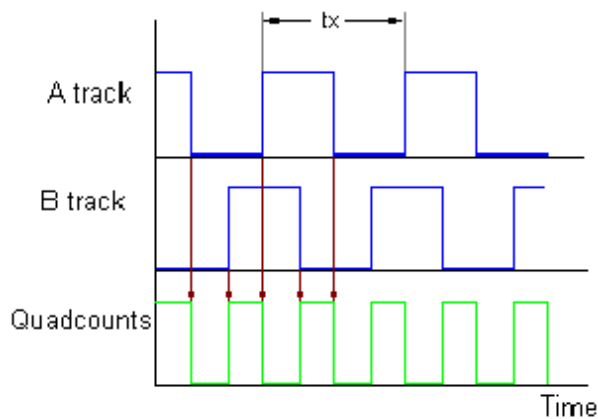

Figure 28: Derivation of quad counts

- Absolute value encoder - This is a special form of incremental encoder, as it indicates not only the speed and direction of rotation but also the absolute physical position. This is communicated via transfer of the position in parallel form or in the form of a telegram in serial form. Absolute value encoders also come in two versions: Single-Turn encoders supply an absolute position on a shaft rotation; Multi-Turn encoders can report the absolute position via a specific quantity, or via a freely-definable number of rotations.

- Track error - The synchronizing controller of the slave drive uses the master drive signal and the gear ratio to calculate a reference position value for the slave drive. The deviation of the feedback position from the calculated position is known as the track error. This is specified in quad counts. The maximum track error is also a threshold value that defines the permitted operating area of the synchronizing controller.

- Accuracy - This value specifies the permitted deviation between the master and slave at which synchronization is still present.

- PPR - Pulses per revolution

- Virtual master - If several axes are to travel in synchrony, or if the synchronization error is so to be kept as small as possible, it is often more advantageous not to take the reference position from a drive, but to have a master that simulates the reference position. This has the advantage that the cycle times of the individual drives are not added. These differences are illustrated below for the synchronous control of three conveyor belts. First, we show the classic synchronization procedure, where the reference value signal is taken from the preceding drive in each case.

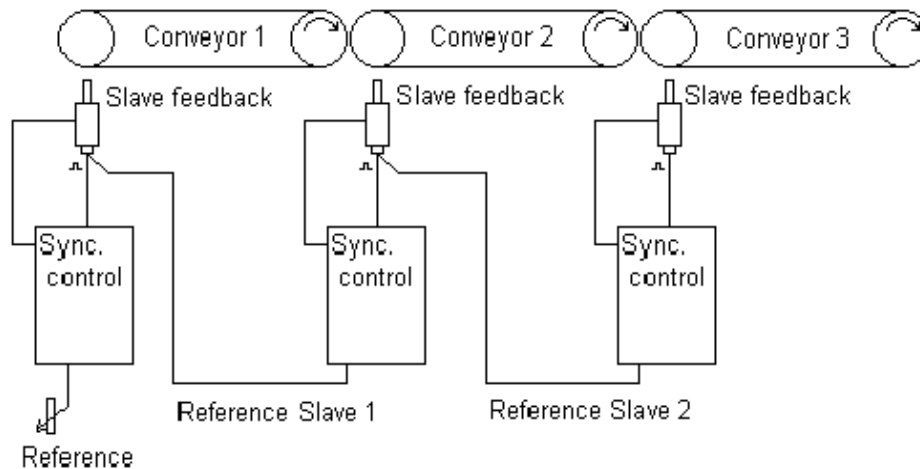

Figure 29: Synchronization without virtual master

As can be seen from the diagram below, at Start, as well as with every change in speed of the master drive, the cycle times are added; they are then compensated for again based on the control characteristics of the controller in question.

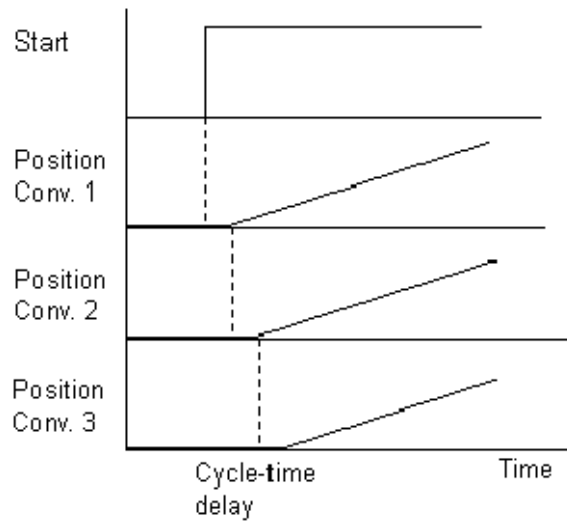

Figure 30: Addition of the cycle times

In this case, the same application is realised by means incorporating a virtual master. Although the way that the reference value is introduced at the first belt is analogous, the value is used to set the virtual master signals.

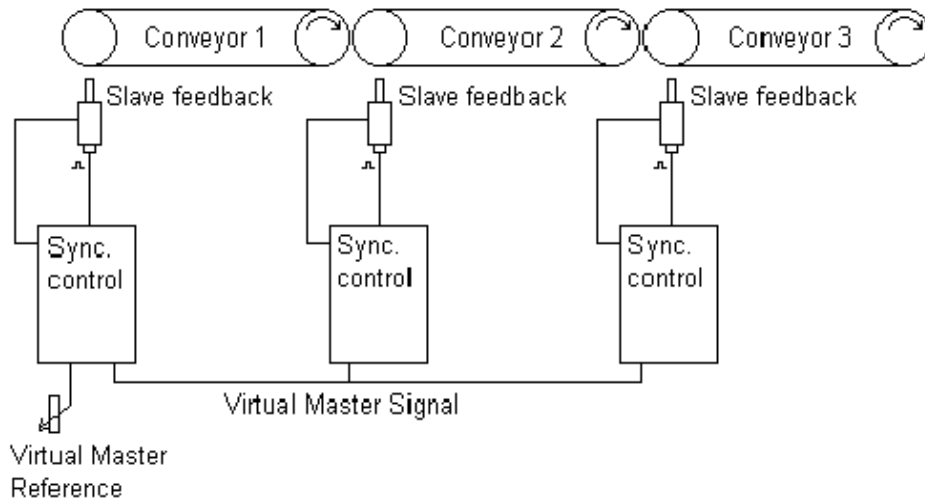

Figure 31: Synchronization with virtual master

It can be seen from the diagram below that the cycle time error is not added; instead, one cycle time applies for all the drives. The advantage of this is that the control has fewer errors to correct.

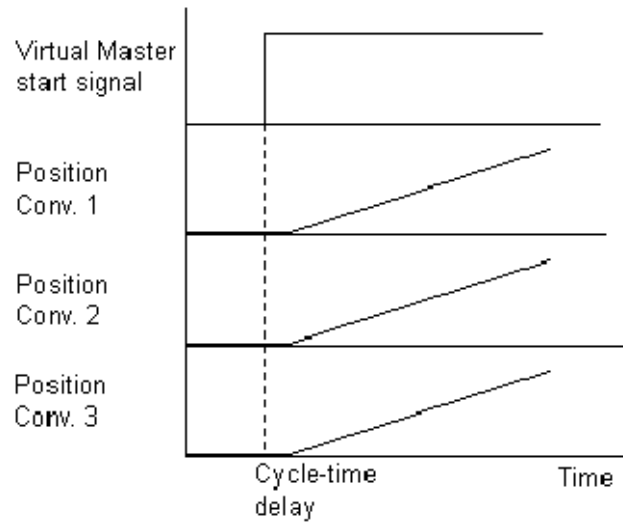

Figure 32: No addition of the cycle times

List of illustrations

Figure 1: Calculation example	5
Figure 6: Master-Slave connection	14
Figure 7: Virtual Master-Slave connection	14
Figure 8: Control behaviour with speed synchronization.....	36
Figure 9: Mixing. Speed synchronizing control.....	36
Figure 10: SyncStart with speed synchronization	37
Figure 11: Up/down factor with speed synchronization.....	38
Figure 12: Hold speed.....	39
Figure 13: Changing the gear ratio in speed synchronization	40
Figure 14: Wiring diagram – Batch control	41
Figure 15: Control behaviour with position synchronization.....	48
Figure 16: Embossing with position synchronization	48
Figure 17: Synchronizing to a stationary master.....	49
Figure 18: Synchronizing to a running master	49
Figure 19: Position displacement.....	50
Figure 20: Wiring diagram – application example.....	51
Figure 21: Control behaviour with marker synchronization.....	58
Figure 22: Conveyor belt with marker synchronization	58
Figure 23: Initial start-up with marker synchronization	59
Figure 24: Marker correction during operation.....	60
Figure 26: Wiring diagram - conveyor belt regulation.....	61
Figure 27: Incremental encoder signals	79
Figure 28: Derivation of quad counts	79
Figure 29: Synchronization without virtual master	80
Figure 30: Addition of the cycle times.....	81
Figure 31: Synchronization with virtual master	81
Figure 32: No addition of the cycle times.....	82

Index

A

Absolute value encoder	80
Acceleration feed forward	71
Accuracy	75, 80
Activate feed forward calculation	74
Admixture	41
Angle synchronization	4, 48
Application example	
admixture	41
embossing patterns on mould	51
packaging	60

B

Band width PID controller	71
Brake off delay	77
Brake on delay	77

C

Calculation sample	
with corrected numerical values	6
with insufficient numerical values	6
Changing the gear ratio with an analogue value	40
Control source synchronizing	77
Control source test run	77

D

Data layout	20
Delta hold speed	74
Denominator	76
Description of Field bus interface	20
Description of parameters	22
Description of terminals	15
admixture	41
embossing patterns on mould	51
packaging	61
Direction of rotation	72
Display parameters	78
D-portion	71

E

Encoder	
Input 1 (master)	12
input 2, MK3D (slave)	13
Output (Virtual master)	13
Encoder cable	13
Encoder monitor	9
Encoder velocity	74
Error messages	69
Error procedure	
admixture	47
embossing patterns on mould	57
packaging	68
Error reference	69
Examples of encoder interface connections	14
External 24 V DC supply	12

F

FFVEL calc	74
Field bus	
control signals	20
interface	20

status signals	21
Fine setting of the gear ratio - admixture	47
Fine setting of the position	
embossing patterns on mould	57
packaging	68
Fixed offset	76
Function description	4
Function diagrams for	
marker synchronization	59
position synchronization	49
speed synchronization	37

G

Gear changing	39
Gear ratio denominator	75
Gear ratio no.	75, 76
Gear ratio numerator	75
Glossary	79

H

Hardware	7
Hold function	39, 73
Hold speed	73
Home acceleration	74
Home function	74
Home run - embossing patterns on mould	57
Home speed	74
How to check the motor connection	
admixture	43
embossing patterns on mould	53
packaging	63
How to optimize the controller	
admixture	44
embossing patterns on mould	53
packaging	64
How to program synchronization	
admixture	46
embossing patterns on mould	55
packaging	66
How to test the incremental encoders	
admixture	43
embossing patterns on mould	53
packaging	63

I

Incremental encoder	79
Initializing the parameters	35
Input status	77
Introduction	4
I-portion	71

L

Limitation for I-portion	71
--------------------------------	----

M

Marker correction during operation	59
Marker interval at the master	73
Marker interval at the slave	73
Marker quantity FAULT	75
Marker quantity READY	75
Marker synchronization	4, 58
Marker synchronizing mode	75
Marker window master	77

Marker window slave.....	77	Slave speed	78
Master	79	Slave speed factor	76
Master encoder resolution	72	Software version number	78
Master encoder type	72	Speed synchronization	4, 36
Master marker quantity	75	Standard RS485-Interface.....	16
Master marker type	73	Starting synchronization	
Master markers	76	admixture.....	47
Master position.....	78	embossing patterns on mould	57
Master speed	78	packaging.....	68
Master speed factor	76	Status of Synchronization.....	78
Maximum speed.....	72	Step time	76
Maximum track error	72	Step width.....	76
Mechanical brake control	5	Stopping synchronization	
Messages.....	69	admixture.....	47
Minimum ramp	72	embossing patterns on mould	57
M-S tolerance speed	75	packaging.....	68
N		Store data.....	71
Numerator	76	Supply voltages	8
O		Switching to another gear ratio	
Operation and operating functions		admixture.....	47
admixture	47	embossing patterns on mould	57
embossing patterns on mould.....	57	packaging.....	68
packaging.....	68	Sync-error.....	78
Option card layout.....	10	Synchronizing error display factor	76
Option card MK3A.....	17	Synchronizing type (Sync type)	74
Option card MK3B (master encoder)	18	SyncStart.....	37
Option card MK3C.....	18	to a running master	49
Option card MK3D (slave encoder).....	19	to a running master after Power ON.....	59
Option card terminals.....	7	to a stationary master.....	49
P		T	
Packaging	60	Technical Data	7, 12
Parameter overview	71	Terminal configuration	
Parameters	22	admixture.....	41
PID calculation	74	embossing patterns on mould	51
Position displacement with a running master.....	50	packaging.....	61
Position synchronization	4, 48	Terminal description	8
P-portion	71	Terminals	12, 15
R		Test run acceleration.....	73
Ramp type.....	72	Test run distance.....	73
Reversing behaviour	72	Test run speed	73
S		Tips and tricks	5
Setting the parameters		Track error.....	77, 78, 80
admixture	42	Type of operation	73
embossing patterns on mould.....	52	U	
packaging.....	62	Up/down factor	37
Slave	79	V	
Slave encoder resolution	72	Velocity feed forward.....	71
Slave encoder type	72	Velocity filter	71
Slave marker quantity	75	Virtual master	80
Slave marker type	73	Virtual master acceleration.....	76
Slave markers	76	Virtual master maximum speed.....	77
Slave position.....	78	Virtual master reference value	76
		VLT control card terminals	7



VLT® 5000/VLT® 5000 FLUX



Operating Instructions Synchronizing Controller

VLT® frequency converters **BAUER** geared motors

Danfoss can accept no responsibility for possible errors in catalogues, brochures and other printed material. Danfoss reserves the right to alter its products without notice. This also applies to products already on order provided that such alterations can be made without subsequential changes being necessary in specifications already agreed. All trademarks in this material are property of the respective companies. Danfoss and the Danfoss logotype are trademarks of Danfoss A/S. All rights reserved.

