

BF3RX

High accuracy fiber optic amplifier with twin adjuster



■ Features

- Convenient DIN rail mounting type
- High speed response : Max. 1ms
- Able to adjust sensitivity with high accuracy by dual adjuster
- Selectable Light ON/Dark ON mode by control wire
- Reverse power polarity and short-circuit (Overcurrent) protection circuit
- Able to use for explosion proof(Fiber part)
- Adjustable length with free cut type fiber optic cable



⚠ Please read "Caution for your safety" in operation manual before using.

■ Specifications

Model	BF3RX	BF3RX-P
Response time	Max. 1ms	
Power supply	12-24VDC \pm 10% (Ripple P-P:Max. 10%)	
Current consumption	Max. 40mA	
Light source	Red LED (Modulated)	
Sensitivity adjustment	Adjuster (Dual adjustment : Coarse adjustment, Fine adjustment)	
Operation mode	Selectable Light ON/Dark ON by control wire	
Control output	<ul style="list-style-type: none"> ● NPN open collector output  Load voltage : Max. 30VDC, Load current : Max. DC200mA, Residual voltage : Max. 1VDC 	<ul style="list-style-type: none"> ● PNP open collector output  Output voltage : Min. (Power supply-2.5)VDC Load current : Max. DC200mA
Protection circuit	Reverse power polarity, Output short-circuit (Overcurrent) protection circuit	
Indication	Operation indicator : Red LED	
Connection	Outgoing cable (2m)	
Insulation resistance	Min. 20M Ω (at 500VDC mega)	
Noise strength	\pm 240V the square wave noise (pulse width:1 μ s) by the noise simulator	
Dielectric strength	1,000VAC 50/60Hz for 1minute	
Vibration	1.5mm amplitude at frequency of 10 ~ 55Hz in each of X, Y, Z directions for 2 hours	
Shock	500m/s ² (50G) in X, Y, Z directions for 3 times	
Ambient illumination	Sunlight : Max. 11,000lx, Incandescent lamp : Max. 3,000lx	
Ambient temperature	-10 ~ +50 $^{\circ}$ C (at non-freezing status), Storage : -25 ~ +70 $^{\circ}$ C	
Ambient humidity	35 ~ 85%RH, Storage : 35 ~ 85%RH	
Material	Case : ABS	
Cable	4P, ϕ 5mm, Length : 2m	
Unit weight	Approx. 90g	

Fiber Optic Amplifier

Feature data

Transmitted beam

Measurement : BF3RX + FT-420-10

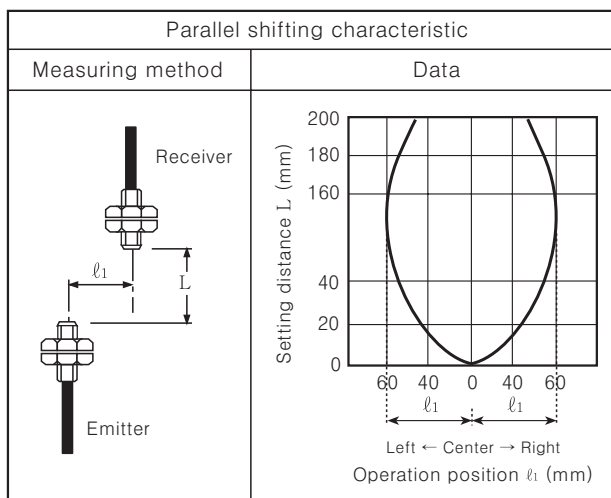

Diffuse reflective

Measurement : BF3RX + FD-620-10

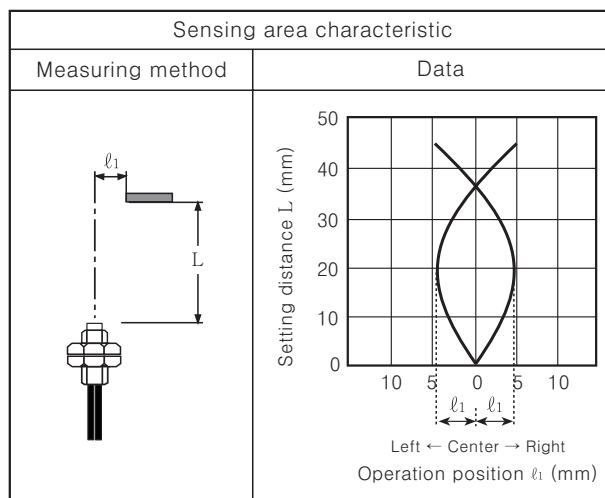

Control output diagram

BF3RX

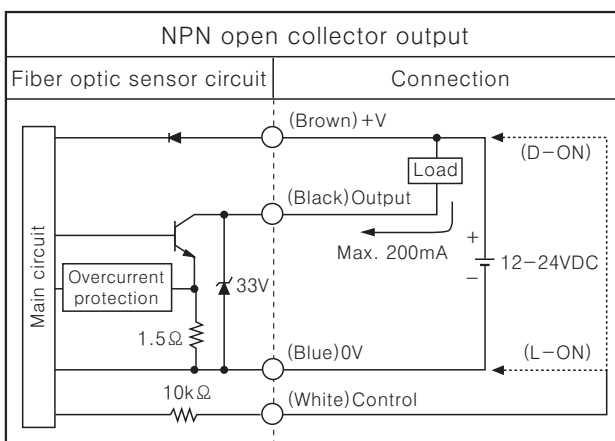

BF3RX-P

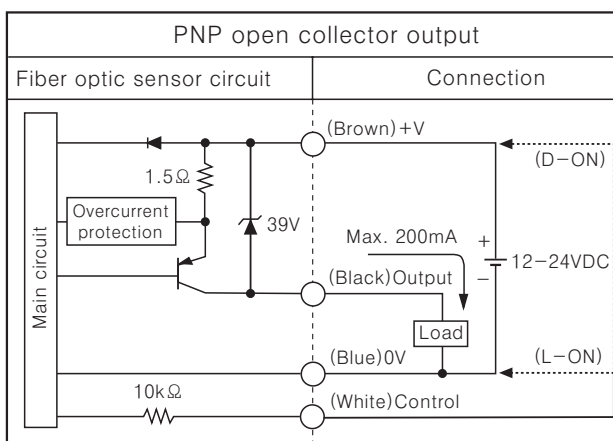

※When select Dark ON or Light ON, please use control wire(White) Light ON : Connect control wire to 0V
Dark ON : Connect control wire to +V

Operation mode

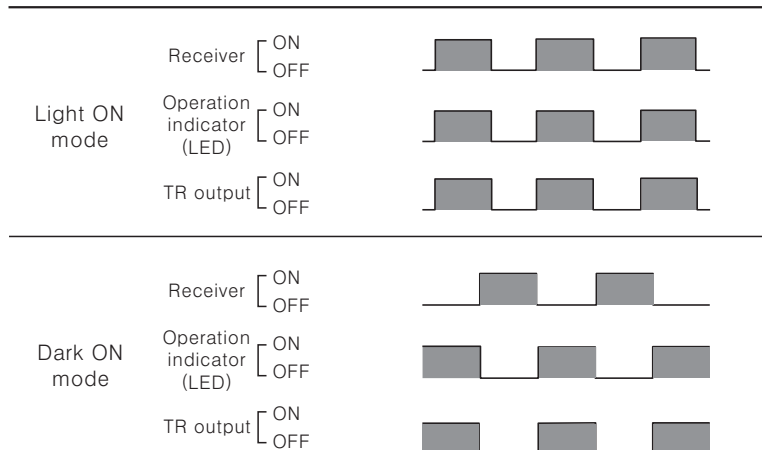

(A) Counter

(B) Timer

(C) Temp. controller

(D) Power controller

(E) Panel meter

(F) Tacho/Speed/Pulse meter

(G) Display unit

(H) Sensor controller

(I) Switching power supply

(J) Proximity sensor

(K) Photo electric sensor

(L) Pressure sensor

(M) Rotary encoder

(N) Stepping motor & Driver & Controller

(O) Graphic panel

(P) Production stoppage models & replacement

BF3RX

Connections

BF3RX

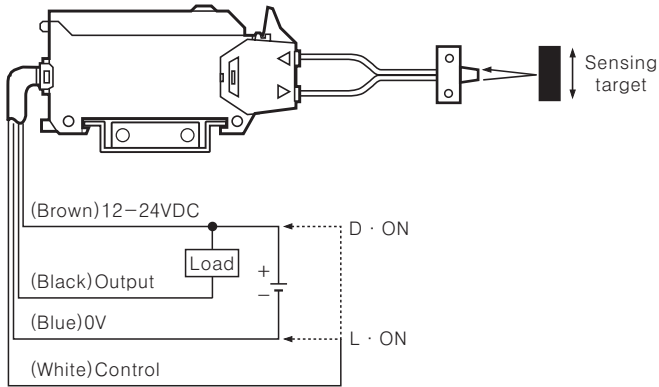

BF3RX-P

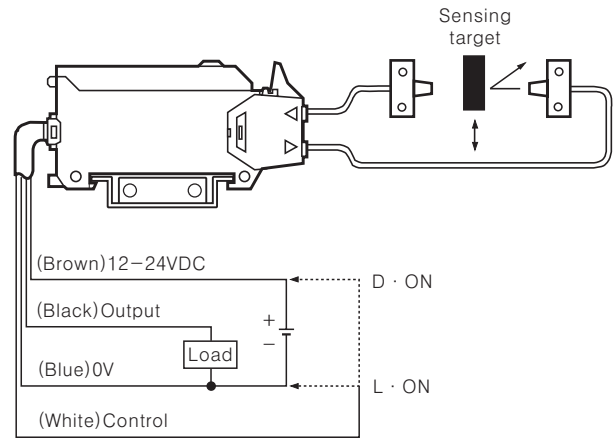

- ※ Enable to use as Diffuse reflective type or Transmitted beam type according to the fiber Optic Cable.
- ※ **Adapter** marked Fiber Optic Cable should be used with Adapter ().
- ※ GT-420-14H2 cannot be used because the length inserted into Amp is too short.

Dimensions

(Unit:mm)

Product

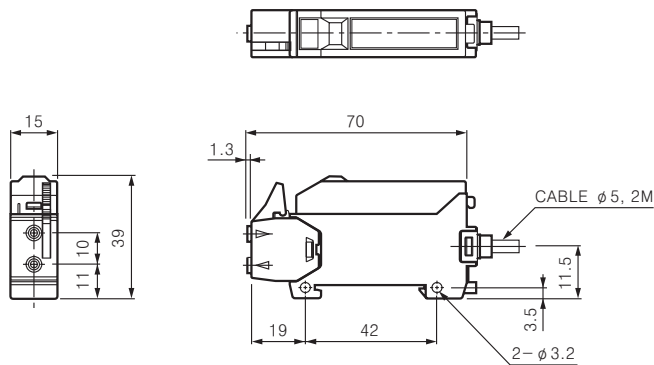

Bracket

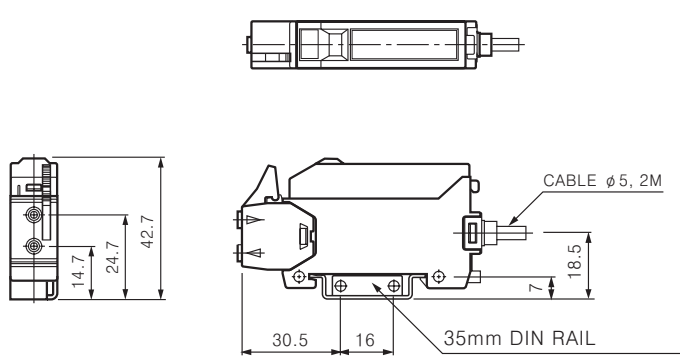



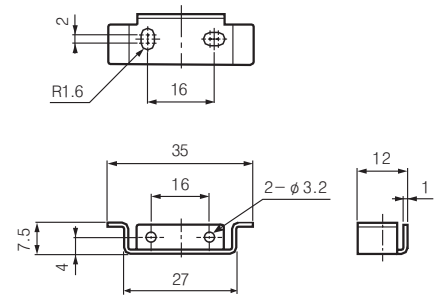











Bracket

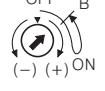
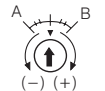

Fiber Optic Amplifier

■ Sensitivity adjustment

- Adjust as the optimum sensitivity according to the order as shown below.
- Please observe below chart because operation lamp will be changed by sensing method.

Order	Sensing type		Adjustment	Adjuster	
	Reflective	Transmitted beam		COARSE	FINE
1	Initial setting		Adjuster(Coarse) should be fixed at min. and fixed at center (▼) for Fine adjustment.		
2	Light ON 	Light ON 	Fix adjuster(Coarse) to ON position by turning clockwise slowly when light is being received.		
3	Light ON 	Light ON 	Turn adjuster(Fine) until it is OFF toward(-), and turn until it is ON toward(+) again, then confirm that this will be A position.	Adjuster(Coarse) is not required to set afterwards.	
4	Dark ON 	Dark ON 	And then turn adjuster(Fine) until it is ON toward(+), and turning until it is OFF toward(-) again when light is not received. Then confirm that this position will be B position. (When it will not be ON, max. position will be B.)		
5	—	—	Fix it at middle of A and B position. This will be the best position to set.		
6	Light ON 	Light ON 	If you cannot adjust as above method, set adjuster(Fine) at max. position toward(+), then execute again.		

(A) Counter

(B) Timer

(C) Temp. controller

(D) Power controller

(E) Panel meter

(F) Tacho/ Speed/ Pulse meter

(G) Display unit

(H) Sensor controller

(I) Switching power supply

(J) Proximity sensor

(K) Photo electric sensor

(L) Pressure sensor

(M) Rotary encoder

(N) Stepping motor & Driver & Controller

(O) Graphic panel

(P) Production stoppage models & replacement