

BM Series

Small and light, popular type photoelectric sensor

■ Features

- Easy to mount at a narrow space with small size and light weight.
- Convenient to adjust the sensitivity by external sensitivity adjustment control.
(Applied to diffuse reflective type only)
- Easy to mount by screw type in mounting hole.
- Reverse power polarity protection circuit.



(MS-2)

(MS-5)

*MS-5 is sold separately.

! Please read "Caution for your safety" in operation manual before using.



■ Specifications

Model	BM3M-TDT	BM1M-MDT	BM200-DDT
Sensing type	Transmitted beam	Retroreflective	Diffuse reflective
Sensing distance	3m	(*1) 0.1 ~ 1m	(*2) 200mm
Sensing target	Opaque materials of min. ϕ 8mm	Opaque materials of min. ϕ 60mm	Transparent, Translucent, Opaque materials
Hysteresis	—————		Max. 10% at rated setting distance
Response time	Max. 3ms		
Power supply	12-24VDC \pm 10% (Ripple P-P : Max. 10%)		
Current consumption	Max. 45mA	Max. 40mA	
Light source	Infrared LED(modulated)		
Sensitivity adjustment	Fixed		Adjuster
Operation mode	Dark ON		Light ON Dark ON
Control output	NPN open collector output \Rightarrow Load voltage : Max. 30VDC, Load current : Max. 100mA, Residual voltage : Max. 1V		
Protection circuit	Reverse polarity protection		
Indication	Operation indicator : Red LED		
Connection	Outgoing cable		
Insulation resistance	Min. 20M Ω (at 500VDC mega)		
Noise strength	\pm 240V the square wave noise(pulse width:1 μ s) by the noise simulator		
Dielectric strength	1,000VAC 50/60Hz for 1minute		
Vibration	1.5mm amplitude at frequency of 10 ~ 55Hz in each of X, Y, Z directions for 2 hours		
Shock	500m/s ² (50G) in X, Y, Z directions for 3 times		
Ambient illumination	Sunlight : Max. 11,000lx, Incandescent lamp : Max. 3,000lx		
Ambient temperature	-10 ~ +60 $^{\circ}$ C (at non-freezing status), Storage : -25 ~ +70 $^{\circ}$ C		
Ambient humidity	35 ~ 85%RH, Storage : 35 ~ 85%RH		
Material	Case : ABS, Lens : PMMA		
Cable	3P(2P for Transmitted beam type), ϕ 4mm, Length : 2m		
Accessories	Individual	—————	Reflector(MS-2) Adjustment driver
	Common	Fixing bracket, Bolts/nuts	
Approval	CE		
Unit weight	Approx. 170g	Approx. 105g	Approx. 88g

※(*1) It is mounting distance between sensor and reflector MS-2 and it is same when MS-5 is used. It is detectable under 0.1m.

※(*2) It is for Non-glossy white paper(100 \times 100mm)

Amplifier Built-in Type for General Purpose

Feature data

⊙ Transmitted beam

● BM3M-TDT

Parallel shifting characteristic		Angle characteristic	
Measuring method	Data	Measuring method	Data

⊙ Retroreflective

● BM1M-MDT

Parallel shifting characteristic		Sensor angle characteristic	
Measuring method	Data	Measuring method	Data

⊙ Retroreflective

● BM1M-MDT

Reflector angle characteristic	
Measuring method	Data

⊙ Diffuse reflective

● BM200-DDT

Sensing area characteristic	
Measuring method	Data
<p>Standard sensing target : Non-glossy white paper 200×200mm</p>	

(A) Counter

(B) Timer

(C) Temp. controller

(D) Power controller

(E) Panel meter

(F) Tacho/Speed/Pulse meter

(G) Display unit

(H) Sensor controller

(I) Switching power supply

(J) Proximity sensor

(K) Photo electric sensor

(L) Pressure sensor

(M) Rotary encoder

(N) Stepping motor & Driver & Controller

(O) Graphic panel

(P) Production stoppage models & replacement

BM Series

Control output diagram

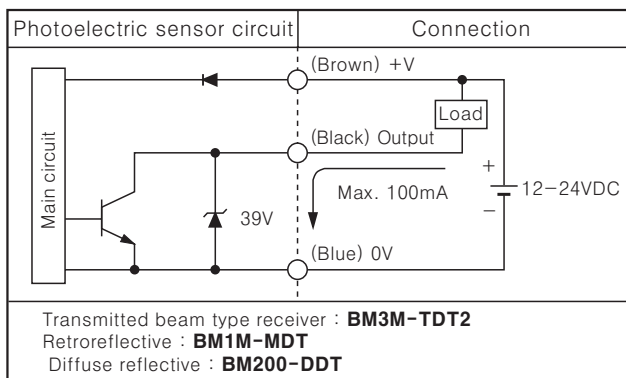

Operation mode

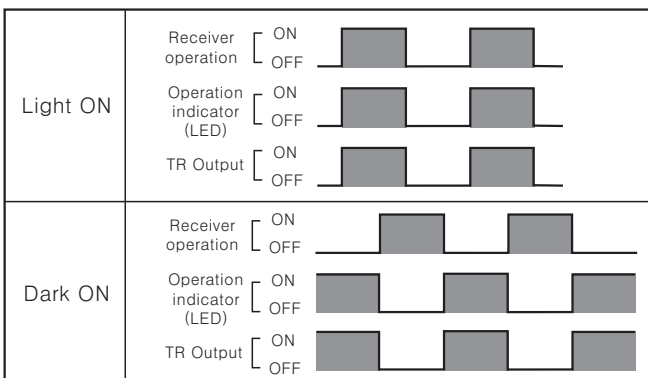

Connections

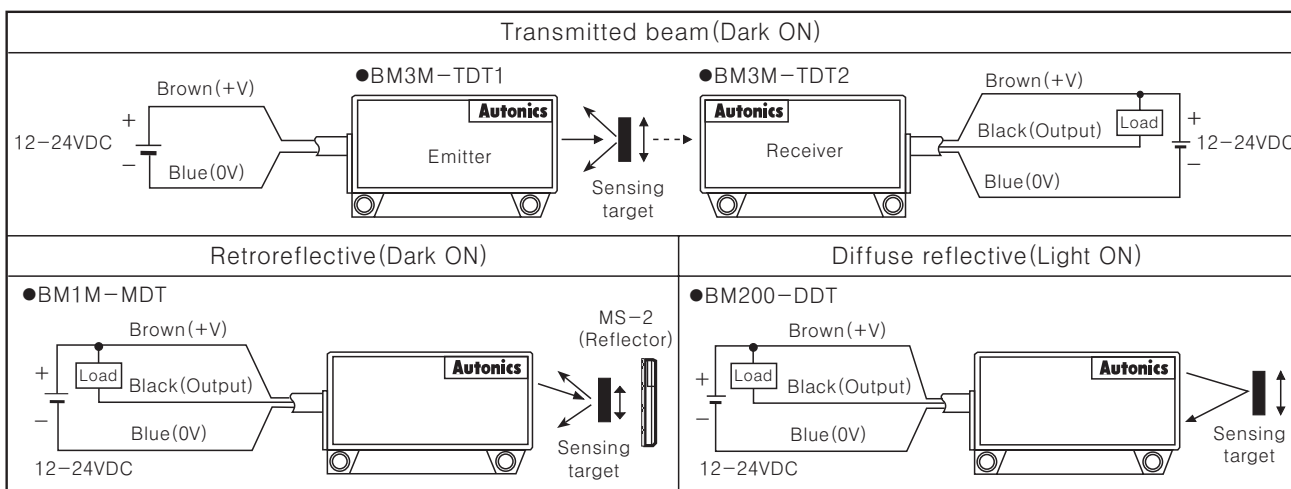

Dimensions

Product

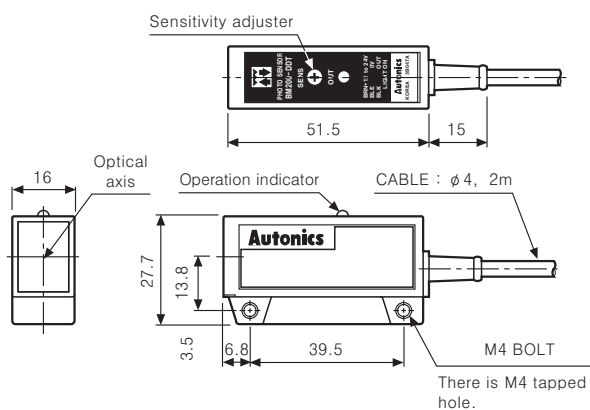

Bracket

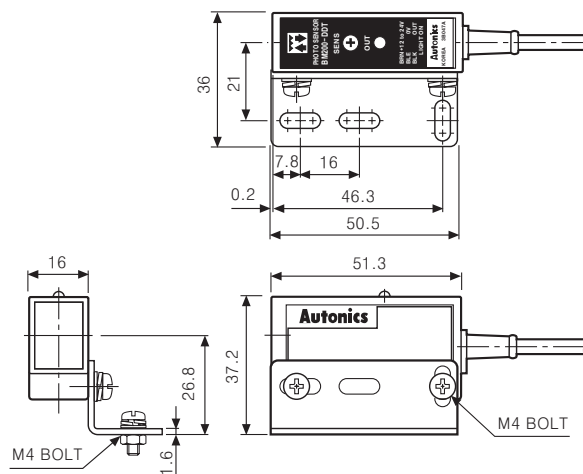

Reflector

< MS-2 >

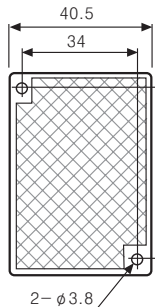

< MS-5 >

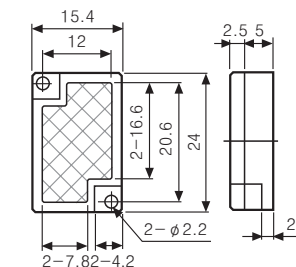

Bracket

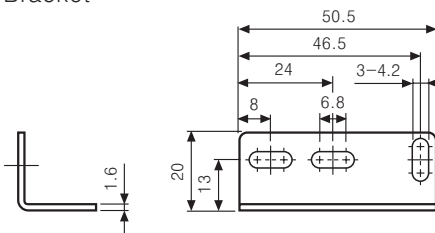

(Unit:mm)

Amplifier Built-in Type for General Purpose

■ Mounting and sensitivity adjustment

○ Transmitted beam type

1. Supply the power to the photoelectric sensor, after set the emitter and the receiver facing each other.
 2. Set the receiver in the middle of the operation range of indicator adjusting the receiver or the emitter right and left, up and down.
 3. Adjust up and down direction as the same.
 4. After adjustment, check the stability of operation putting the object at the optical axis.
- ※ If the sensing target is translucent body or smaller than $\varnothing 8\text{mm}$, it can be missed by sensor because light penetrate it.

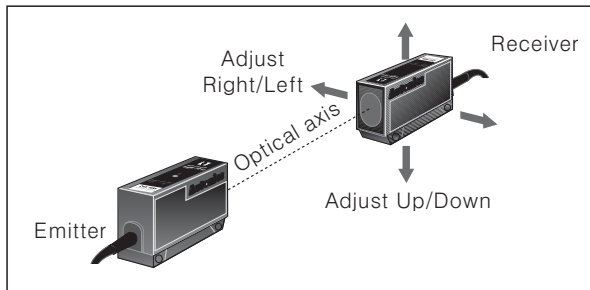

○ Diffuse reflective type

1. The sensitivity should be adjusted depending on a sensing target or mounting place.
2. Set the target at a position to be detected by the beam, then turn the adjuster until position ① where the indicator turns on from min. position of the adjuster.
3. Take the target out of the sensing area, then turn the adjuster until position ② where the indicator turns on. If the indicator does not turn on, Max. position is position ②.
4. Set the adjuster at the center of two switching position ①, ②.

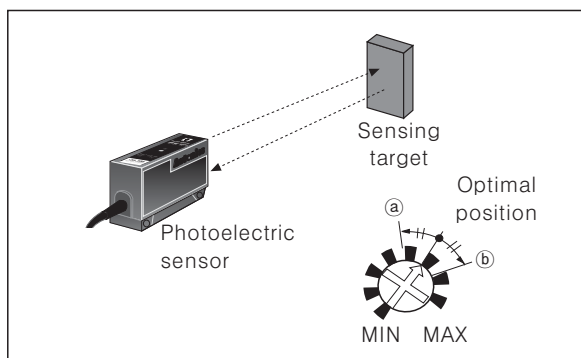

- ※ The sensing distance indicated on specification chart is for $200 \times 200\text{mm}$ of non-glossy white paper. Be sure that it can be different by size, surface and gloss of target.

○ Retroreflective type

1. Supply the power to the photoelectric sensor, after set the emitter and the reflector (MS-2) facing to each other.
 2. Set the reflector or photoelectric sensor in the middle of the operation range of indicator adjusting the mirror or the sensor right and left, up and down.
 3. Adjust up and down direction as the same.
 4. After adjustment, check the stability of operation putting the object at the optical axis.
- ※ If use more than 2 photoelectric sensors in parallel, the space between them should be more than 30cm.

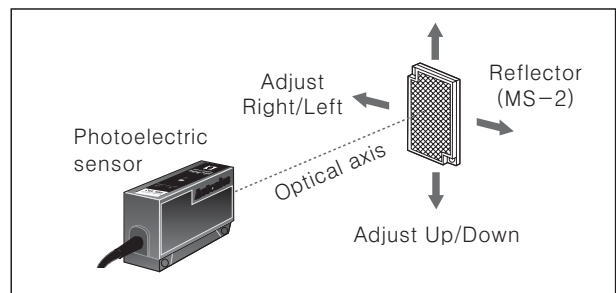

- ※ If reflectance of target is higher than non-glossy white paper, it might cause malfunction by reflection from the target when the target is near to photoelectric sensor. Therefore enough space between the target should be used and photoelectric sensor or the surface of target should be installed at an angle of $30^\circ \sim 45^\circ$ against optical axis.

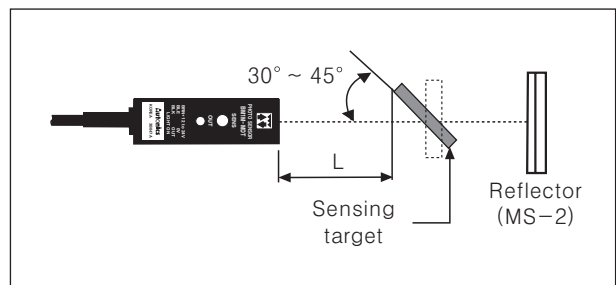

- ※ If the installing place is too small, please use MS-5 instead of MS-2 for same sensing distance.



(A)	Counter
(B)	Timer
(C)	Temp. controller
(D)	Power controller
(E)	Panel meter
(F)	Tacho/Speed/Pulse meter
(G)	Display unit
(H)	Sensor controller
(I)	Switching power supply
(J)	Proximity sensor
(K)	Photo electric sensor
(L)	Pressure sensor
(M)	Rotary encoder
(N)	Stepping motor & Driver & Controller
(O)	Graphic panel
(P)	Production stoppage models & replacement