

Autonics ROTARY ENCODER (ABSOLUTE TYPE) EP58 SERIES



Thank you very much for selecting Autonics products.
For your safety, please read the following before using.

Caution for your safety

- Please keep these instructions and review them before using this unit.
- Please observe the cautions that follow:
 - Warning** Serious injury may result if instructions are not followed.
 - Caution** Product may be damaged, or injury may result if instructions are not followed.
- The following is an explanation of the symbols used in the operation manual.
 - Caution:** Injury or danger may occur under special conditions.

Warning

- In case of using this unit with machineries (Nuclear power control, medical equipment, vehicle, train, airplane, combustion apparatus, entertainment or safety device etc), it is required to install fail-safe device, or contact us. It may cause a fire, human injury or property loss.

Caution

- Do not drop water or oil on this unit. It may cause damage or miscontrol due to malfunction.
- Please observe voltage rating. It may shorten the life cycle or damage to the product.
- Please check the polarity of power and wrong wiring. It may cause damage to this unit.
- Do not short circuit the load. It may cause damage to this unit.

Outline

This is an absolute type encoder producing a unique digital code for each distinct angle of shaft divided with fixed ratio from the reference point (shaft=0°). Since each angle has its own digital code, electrical factors can barely have influences on encoder's output. Therefore, it features strong noise strength and no memory back required.

Features

- Shaft diameter ϕ 58mm flange type
- Diverse front mounting styles available
- Various output code (BCD, Binary, Gray code)
- Realization of high resolution (720 division, 1024 division)

Application

- Precision machine tool
- Fabric machinery
- Robot
- Parking system

Ordering information

EP58SC	10	1024	1	R	P	24
Series Diameter ϕ 58mm	Shaft diameter	Resolution/1revolution	Output code	Rotating direction	Control output	Power supply
SC : Shaft Clamping	10 ϕ 10mm	Refer to resolution	1:BCD Code	F:Output value increases at CW direction	P:PNP open collector output	5:5VDC \pm 5%
SS : Shaft Synchro	6 ϕ 6mm		2:Binary Code	R:Output value increases at CCW direction	N:NPN open collector output	
HB : Built-in	8 ϕ 8mm		3:Gray Code	*Shaft based		

*Gray code is optional.

Dimensions

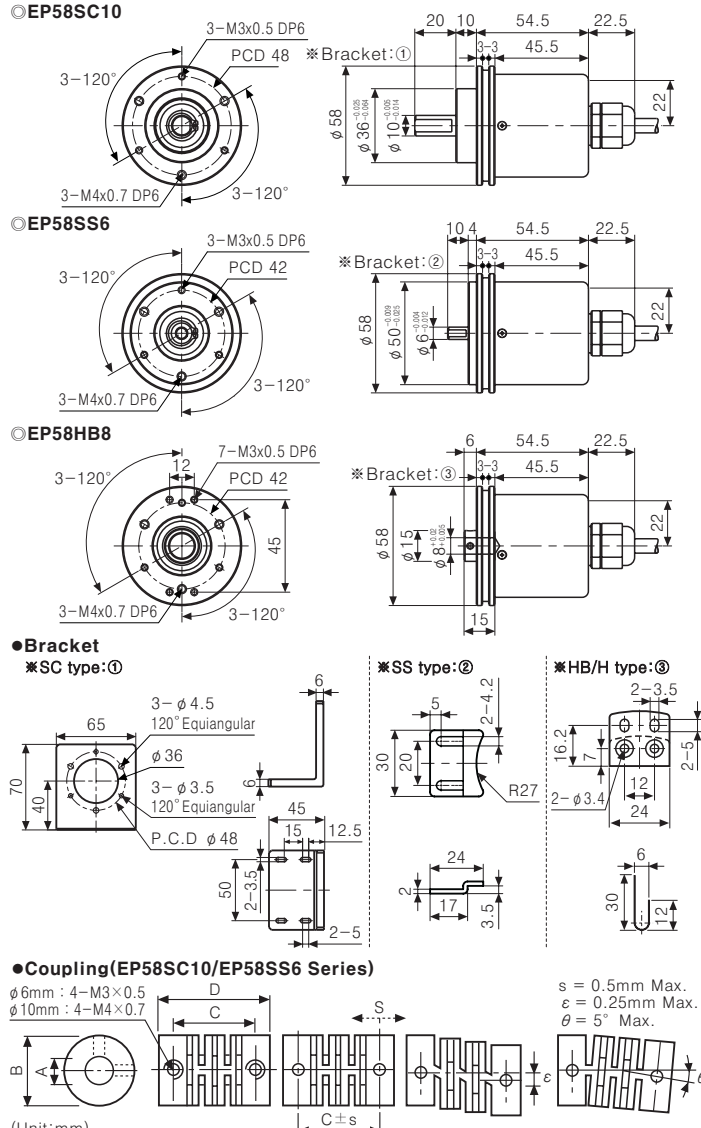

Type	Item	A	B	C	D
EP58SS6 ϕ 6mm	ϕ 6 ^{±0.1}	ϕ 15	16.5	22	
EP58SC10 ϕ 10mm	ϕ 10 ^{±0.1}	ϕ 22	18.2	25	

*When mounting the coupling to encoder shaft, if there is big eccentricity or bend between rotating encoder shaft and mate shaft, it may cause encoder and coupling's life cycle to shorten.
*Do not load overweight on the shaft.
*The above specifications are subject to change without notice.

Specifications

Type	Diameter ϕ 58mm Absolute Rotary Encoder								
Model	PNP open collector output EP58□□-□□□□-□□- P -□				NPN open collector output EP58□□-□□□□-□□- N -□				
Resolution	720, 360, 180, 90, 45 division				1024, 512, 256, 128, 64 division				
Electrical specification	Output code	BCD Code		Binary Code		Gray Code			
	Output phase/Output angle	720 division	TS:Signal Pulse(11bit) TS:0.5° \pm 25'	TS:Signal Pulse(10bit) TS:0.5° \pm 25'	TS:Signal Pulse(10bit) TS:1° \pm 25'	1024 division	TS:Signal Pulse(13bit) TS:0.3515° \pm 15'	TS:Signal Pulse(10bit) TS:0.3515° \pm 15'	TS:Signal Pulse(10bit) TS:0.703° \pm 15'
		360 division	TS:Signal Pulse(10bit) TS:1° \pm 25'	TS:Signal Pulse(9bit) TS:1° \pm 25'	TS:Signal Pulse(9bit) TS:2° \pm 25'	512 division	TS:Signal Pulse(11bit) TS:0.703° \pm 15'	TS:Signal Pulse(9bit) TS:0.703° \pm 15'	TS:Signal Pulse(9bit) TS:1.406° \pm 15'
		180 division	TS:Signal Pulse(9bit) TS:2° \pm 25'	TS:Signal Pulse(8bit) TS:2° \pm 25'	TS:Signal Pulse(8bit) TS:4° \pm 25'	256 division	TS:Signal Pulse(10bit) TS:1.406° \pm 15'	TS:Signal Pulse(8bit) TS:1.406° \pm 15'	TS:Signal Pulse(8bit) TS:2.8125° \pm 15'
		90 division	TS:Signal Pulse(8bit) TS:4° \pm 25'	TS:Signal Pulse(7bit) TS:4° \pm 25'	TS:Signal Pulse(7bit) TS:8° \pm 25'	128 division	TS:Signal Pulse(9bit) TS:2.8125° \pm 15'	TS:Signal Pulse(7bit) TS:2.8125° \pm 15'	TS:Signal Pulse(7bit) TS:5.625° \pm 15'
45 division	TS:Signal Pulse(7bit) TS:8° \pm 25'	TS:Signal Pulse(6bit) TS:8° \pm 25'	TS:Signal Pulse(6bit) TS:16° \pm 25'	64 division	TS:Signal Pulse(7bit) TS:5.625° \pm 15'	TS:Signal Pulse(6bit) TS:5.625° \pm 15'	TS:Signal Pulse(6bit) TS:11.25° \pm 15'		
Control output	PNP open collector output NPN open collector output				Output voltage : Min. (Power supply - 1.5VDC), Load current : Max. 32mA Load current : Max. 32mA, Residual voltage : Max. 1VDC				
Response time(Rising time, Falling time)	Ton=800nsec, Toff=Max. 800nsec(Cable : 2m, I sink = 32mA)								
Max. Response frequency	35kHz								
Power supply	5VDC \pm 5%(Ripple P-P : Max. 5%)				12-24VDC \pm 5%(Ripple P-P : Max. 5%)				
Current consumption	Max. 100mA(disconnection of the load)								
Insulation resistance	Min. 100M Ω (at 500VDC mega for all terminals and case)								
Dielectric strength	750VAC 50/60Hz for 1 minute(all terminals and case)								
Connection	Cable outgoing type(Cable gland)								
Mechanical specification	Starting torque	SC/SS type : Max. 40gf \cdot cm(0.004N \cdot m)				HB type : Max. 90gf \cdot cm(0.009N \cdot m)			
	Moment of inertia	SC/SS type : Max. 15g \cdot cm ² (1.5 \times 10 ⁻⁴ kg \cdot m ²)				HB type : Max. 20g \cdot cm ² (2.0 \times 10 ⁻⁴ kg \cdot m ²)			
	Shaft loading	SC/SS type : Radial : 10kg \cdot f, Thrust : 2.5kg \cdot f				HB type : Radial : 2kg \cdot f, Thrust : 1kg \cdot f			
	Max. allowable revolution	3000rpm							
Vibration	1.5mm amplitude at frequency of 10 to 55Hz(for one minute cycle) in each of X, Y, Z direction for 2 hours								
Shock	Max. 50G								
Ambient temperature	-10 to 70°C(at non-freezing status), Storage:-25 to 85°C								
Ambient humidity	35 to 85%RH, Storage:35 to 90%RH								
Protection	IP50(IEC standard)								
Cable	ϕ 7mm, 15P, Length:2m, Shield cable								
Accessories	ϕ 10mm(SC type)/ ϕ 6mm(SS type) coupling, Fixing bracket								
Unit weight	Clamping : Approx. 435g				Synchro : Approx. 415g				
Approval	Built-IN : Approx. 410g				CE				

360division output waveform(BCD code output) : Representative model

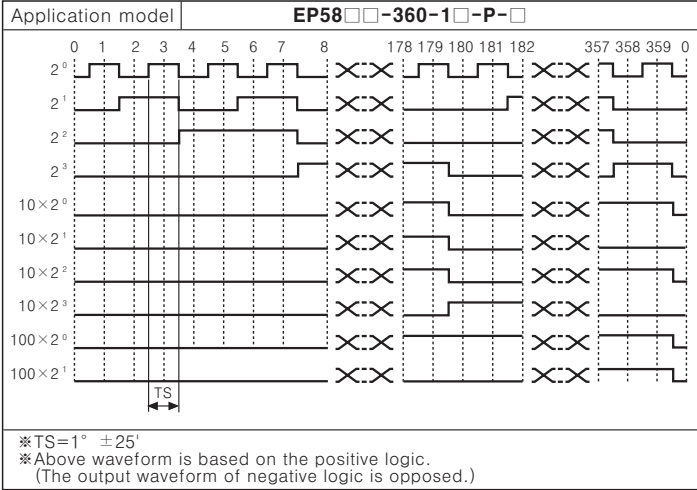

360division output waveform(Binary code output) : Representative model

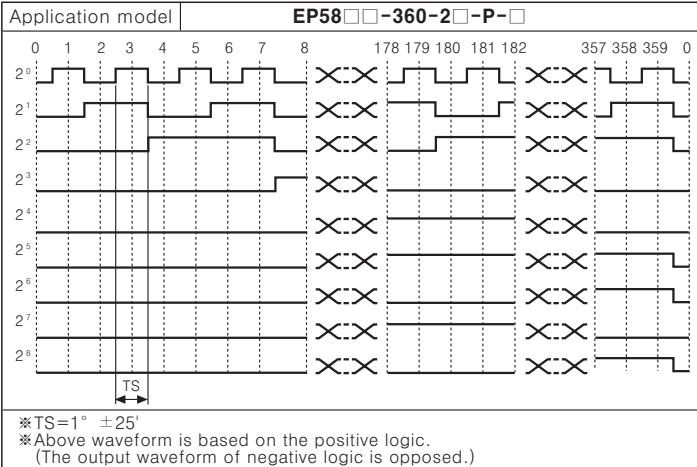

1024division output waveform(BCD code output) : Representative model

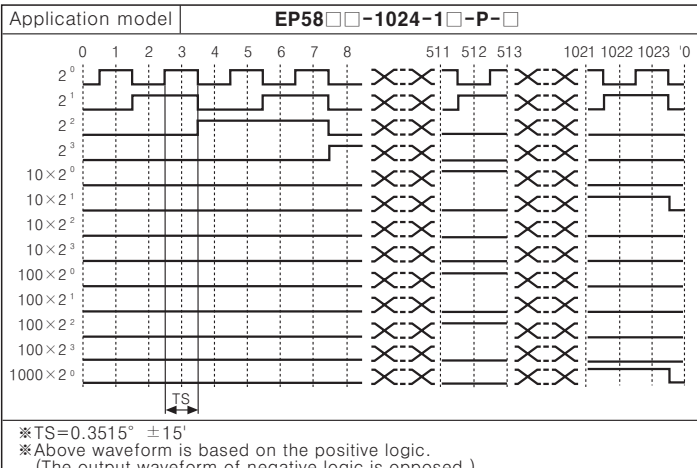

1024division output waveform(Binary code output) : Representative model

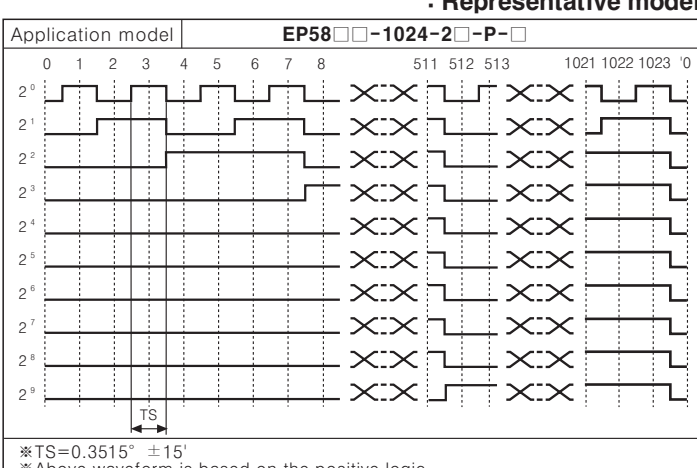

Control output circuit

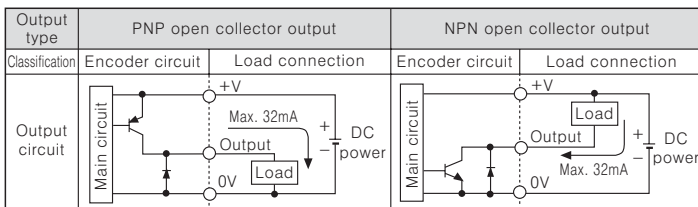

*In case of overload or short on output terminal, it may cause output circuit break.

Connections

Color	Resolution	45 division		64 division		90 division		128 division		180 division		256 division		360 division		512 division		720 division		1024 division	
		+	-	+	-	+	-	+	-	+	-	+	-	+	-	+	-	+	-	+	-
White		+V		GND(0V)																	
Black		GND(0V)																			
Brown		2 ⁰																			
Red		2 ¹																			
Orange		2 ²																			
Yellow		2 ³																			
Blue		(2 ⁰ \times 10)																			
Purple		(2 ¹ \times 10)																			
Gray		(2 ² \times 10)																			
White/Brown		N.C																			
White/Red		N.C																			
White/Orange		N.C																			
White/Yellow		N.C																			
White/Blue		N.C																			
White/Purple		N.C																			
Shield wire		F.G																			

Binary Code/Gray Code

Color	Resolution	45 division		64 division		90 division		128 division		180 division		256 division		360 division		512 division		720 division		1024 division	
		+	-	+	-	+	-	+	-	+	-	+	-	+	-	+	-	+	-	+	-
White		+V		GND(0V)																	
Black		GND(0V)																			
Brown		2 ⁰																			
Red		2 ¹																			
Orange		2 ²																			
Yellow		2 ³																			
Blue		2 ⁴																			
Purple		2 ⁵																			
Gray		N.C																			
White/Brown		N.C																			
White/Red		N.C																			
White/Orange		N.C																			
White/Yellow		N.C																			
White/Blue		N.C																			
White/Purple		N.C																			
Shield wire		F.G																			

- Non-using wires must be insulated.
- Encoder case and shield wire must be grounded.
- N.C(Not Connected) : Not using.
- Please make sure that short is not occurred when wiring output lines because an exclusive driver IC is used at output circuit.

Caution for using

- Installation
 - Handle the unit with care since it consists of precision components.
 - Be careful not to make eccentricity and deflection angle larger, it may shorten the life cycle.
 - Do not put strong impact when insert coupling into shaft.
 - Please set Zero-Position with metallic tool for sub-mounting, then use this unit.
- For using
 - Please connect shield wire to F.G terminal.
 - Do not connect and cut circuit during power on, or it may cause damage to the unit.
 - When use switching power, install the surge absorber on power line and make the wire as short as possible to avoid noise.
- Environment
 - Please do not use this unit with below environment, it may cause malfunction.
 - Place where this unit or component may be damaged by strong vibration or impact.
 - Place where there are lots of flammable or corrosive gases.
 - Place where strong magnet field or electric noise occurs.
 - Place where is beyond of rating temperature or humidity.
 - Place where strong acids or alkali near by.
- Vibration and Impact
 - When the strong impact loads on this unit, it may cause an error.
 - High resolution encoder can be easily affected by vibration, fix the bracket firmly to install.
 - Please use metallic coupling when the application needs severe acceleration or deceleration frequently.
- Wire connection
 - Do not draw the wire with over strength 30N after wiring.
 - If wire encoder cable with high voltage line or power cable in the same conduit, it may cause a malfunction or mechanical problem. Please wire it separately or use separated conduit.

*It may cause malfunction if above instructions are not followed.

Major products

- PROXIMITY SENSOR
- AREA SENSOR
- DOOR/DOOR SIDE SENSOR
- PRESSURE SENSOR
- SENSOR CONTROLLER
- SWITCHING POWER SUPPLY
- TEMPERATURE CONTROLLER
- TEMPERATURE/HUMIDITY TRANSDUCER
- TACHOMETER/PULSE(RATE) METER
- PANEL METER
- SIGNAL CONVERTOR
- TIMER
- GRAPHIC PANEL, LOGIC PANEL
- STEPPING MOTOR & DRIVER & MOTION CONTROLLER
- PHOTOELECTRIC SENSOR
- FIBER OPTIC SENSOR
- ROTARY ENCODER
- RECORDER
- COUNTER
- DISPLAY UNIT

Autonics Corporation
http://www.autonics.com

Satisfiable Partner For Factory Automation

HEAD QUARTERS
41-5, Yongdang-dong, Yangsan-si, Gyeongsang, 626-847, Korea

ROVERSE SALES :
Blg. 402 3rd Fl., Bucheon Techno Park, 193, Yaldae-dong, Wonmi-gu, Bucheon-si, Gyeonggi-do, 420-734, Korea
TEL:82-32-610-2730 / FAX:82-32-329-0728
E-mail : sales@autonics.com

The proposal of a product improvement and development : Product@autonics.com

EP-KE-09-0160