

Autonics

**PHOTOELECTRIC SENSOR
BUP SERIES**

M A N U A L



Thank you very much for selecting Autonics products.
For your safety, please read the following before using.

Caution for your safety

- *Please keep these instructions and review them before using this unit.
- *Please observe the cautions that follow;
- Warning** Serious injury may result if instructions are not followed.
- Caution** Product may be damaged, or injury may result if instructions are not followed.
- *The following is an explanation of the symbols used in the operation manual.
- Caution:**Injury or danger may occur under special conditions.

Warning

1. In case of using this unit with machineries(Nuclear power control, medical equipment, vehicle, train, airplane, combustion apparatus, entertainment or safety device etc), it requires installing fail-safe device, or contact us for information on type required.
It may result in serious damage, fire or human injury.
2. Do not disassemble and modify this unit, when it requires.
If needs, please contact us.
It may give an electric shock and cause a fire.

Caution

1. This equipment shall not be used outdoors.
It might shorten the life cycle of the product or give an electric shock.
2. Do not use this unit in place where there is flammable or explosive gas.
It may cause a fire or explosion.
3. Please observe voltage rating and do not supply AC power.
It may result in damage to this unit.
4. Please check the polarity of power and wrong wiring.
It may result in damage to this unit.
5. Do not use this unit in place where there is vibration or impact.
It may result in damage to this unit.
6. In cleaning the unit, do not use water or an oil-based detergent
It might cause an electric shock or fire that will result in damage to this product.

Ordering information

BUP-50 S-P		
	NPN open collector output	
	P	PNP open collector output
	Fixed sensitivity type	
	S	Adjustable sensitivity VR built-in type
Sensing distance	30	30mm
	50	50mm
	BUP	Series

Operating mode

Operation mode	Light ON mode	Dark ON mode
Receiver operation	Received light	Interrupted light
Operation indicator(LED)	ON	OFF
Output TR	ON	OFF

Note)If the control output terminal is short-circuited or flow beyond rating current, the control signal will not be output normally due protection circuit.

*The above specifications are subject to change without notice.

Specification

Model	BUP-30	BUP-30-P	BUP-30S	BUP-30S-P	BUP-50	BUP-50-P	BUP-50S	BUP-50S-P
Detecting target	Min. ϕ 4mm Opaque		Min. ϕ 1.5mm Opaque		Min. ϕ 4mm Opaque		Min. ϕ 1.5mm Opaque	
Operation mode	Selectable Light ON or Dark ON by control wire							
Detecting distance	30mm				50mm			
Response time	Max. 1ms							
Power supply	12-24VDC \pm 10%(Ripple P-P:Max. 10%)							
Current consumption	Max. 30mA							
Light source	Infrared LED(modulated)							
Sensitivity adjustment	Fixed		Adjustable VR		Fixed		Adjustable VR	
Control output	<ul style="list-style-type: none"> • NPN open collector output Load voltage : Max.30VDC, Load current : Max.200mA, Residual voltage : Max.1V • PNP open collector output Output voltage : Min.(Power supply-2.5)V, Load current : Max.200mA 							
Protection circuit	Reverse polarity protection, Short-circuit protection							
Indication	Power indicator : Green LED, Operation indicator : Red LED							
Connection	Outgoing cable							
Insulation resistance	Min. 20M Ω (500VDC)							
Noise strength	\pm 240V the square wave noise(pulse width:1 μ s) by the noise simulator							
Dielectric strength	1000VAC 50/60Hz for 1minute							
Vibration	1.5mm amplitude at frequency of 10 to 55Hz in each of X, Y, Z directions for 2 hours							
Shock	500m/s ² (50G) in X, Y, Z directions for 3 times							
Ambient illumination	Sunlight : Max. 11,000lx Incandescent lamp : Max. 3,000lx							
Ambient temperature	Operation : -25 to +65 $^{\circ}$ C [BUP-30S(-P) & BUP-50S(-P) : -10 to +60 $^{\circ}$ C], Storage : -25 to +70 $^{\circ}$ C (non-freezing condition)							
Ambient humidity	Operation and storage : 35 to 85%RH(non-freezing condition)							
Protection	IP66(IEC specification)		IP50(IEC specification)		IP66(IEC specification)		IP50(IEC specification)	
Material	Case : ABS, Cap : PC							
Cable	4P, ϕ 4, Length:2m							
Accessories					Driver		Driver	
Weight	Approx. 90g				Approx. 140g			

Dimension

BUP-30, BUP-30-P, BUP-30S, BUP-30S-P

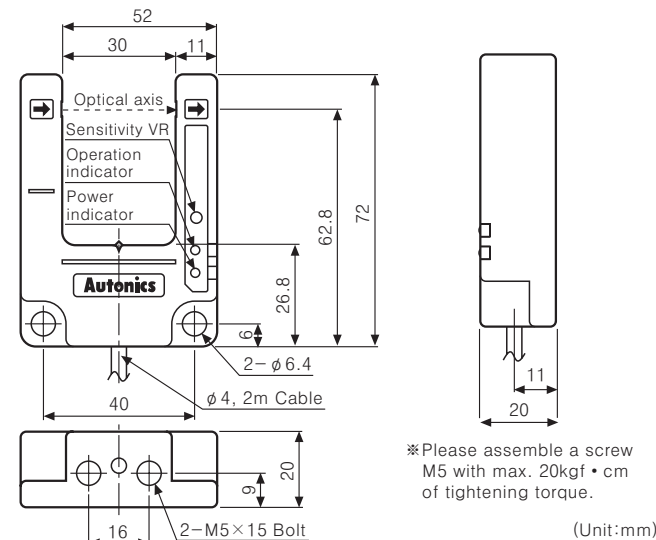

BUP-50, BUP-50-P, BUP-50S, BUP-50S-P

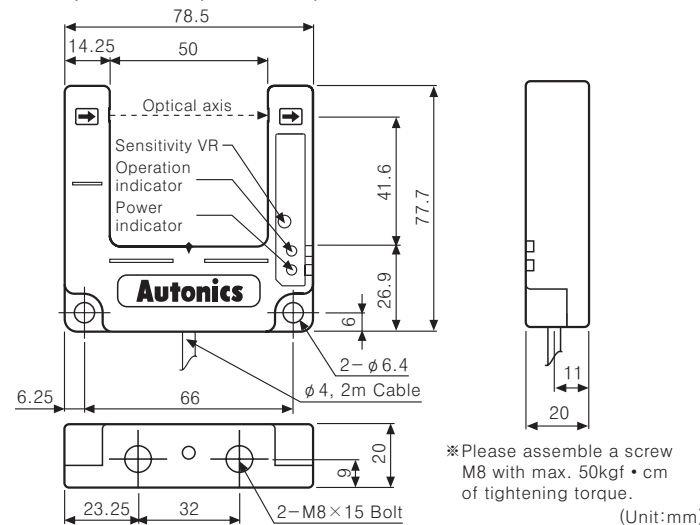

Connection

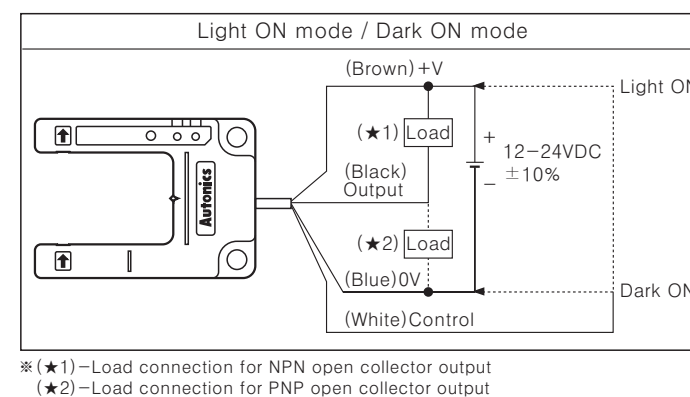

Control output circuit diagram

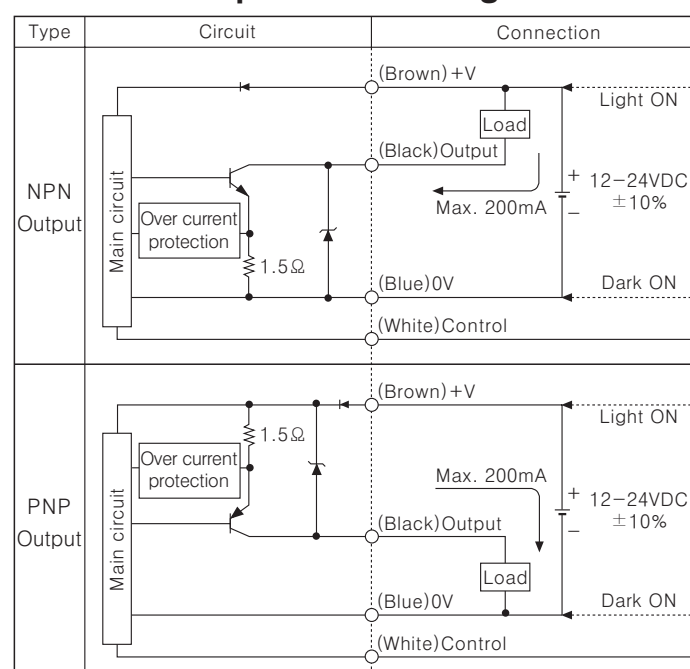

Mounting & Adjustment

Check the position where it will be used and connected then apply the power and set sensitivity as below.

Sensitivity adjustment

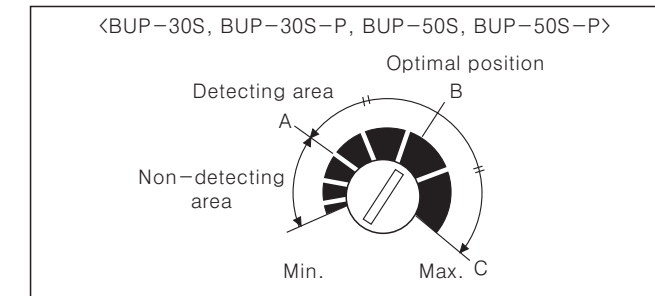

When place a target within detecting range of sensor, turn the VR from minimum position until the LED is turned on or off(Dark on mode/Light on mode), this position is "A". (The LED can be turned on or off where the the lowest sensitivity position.)
Turn the VR to "B" in the middle between "A" and "C"(The highest sensitivity position), this will be the best sensitivity position.

Caution for using

1. Intercept a strong source of light as like sunlight, spotlight within inclination angle range of photoelectric sensor.
2. The photoelectric sensor may cause malfunction under the fluorescent lamp light, so be sure to use cut-off light with panel.
3. When wire the photoelectric sensor with high voltage line, power line in the same conduit, it may cause malfunction or mechanical trouble.
Therefore please wire separately or use different conduit.
4. Avoid installing the unit as following place.
Corrosive gas, oil or dust, strong flux, noise, sunlight, strong alkali, acid.
5. In case of connect DC relay as inductive load to output, please remove surges by using diode or varistor.
6. The photoelectric sensor cable shall be used as short as possible, because it may cause malfunction by noise through the cable.
7. When it is stained by dirt at lens, please clean the lens with dry cloth, but don't use an organic materials such as alkali, acid, chromic acid.
8. When use switching power supply as the source of supplying power, F.G terminal shall be good earth ground and condenser for removing noise shall be installed between 0V and F.G terminal.

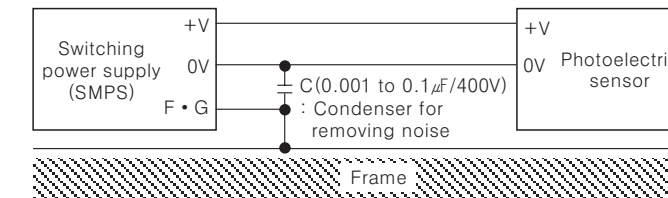

It may cause malfunction if above instructions are not followed.

Major products

- Proximity sensors
- Photoelectric sensors
- Area sensors
- Fiber optic sensors
- Door/Door side sensors
- Pressure sensors
- Rotary encoders
- Sensor controllers
- Switching power supply
- Temperature controllers
- Temperature/Humidity transducers
- Power controllers
- Recorders
- Tachometer/Pulse(Rate) meters
- Panel meters
- Indicators
- Signal converters
- Counters
- Timers
- Display units
- Graphic/Logic panel
- Stepping Motors&Drivers & Motion controllers

Autonics Corporation
http://www.autonics.com

Satisfiable Partner For Factory Automation

■ HEAD QUARTERS :
41-5, Yongdang-dong, Yangsan-si, Gyeongsang, 626-847, Korea

■ OVERSEAS SALES :
Bldg. 402 3rd Fl., Bucheon Techno Park, 193, Yakdae-dong, Wonmi-gu, Bucheon-si, Gyeonggi-do, 420-734, Korea
TEL:82-32-610-2730 / FAX:82-32-329-0728
■ E-mail : sales@autonics.com

The proposal of a product improvement and development : Product@autonics.com