

Autonics

**PHOTOELECTRIC SENSOR
BJN SERIES**

M A N U A L



Dimensions

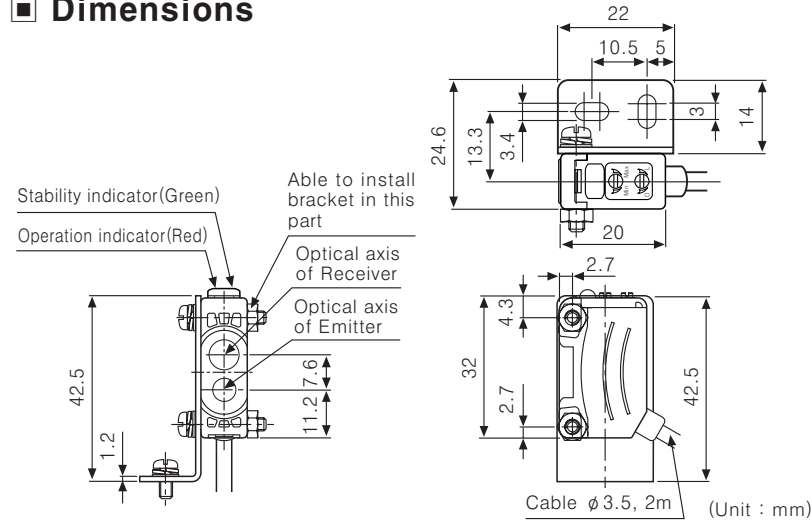

Specifications

		Narrow beam reflective type	
Sensing type	NPN output	BJN50-NDT	BJN100-NDT
	PNP output	BJN50-NDT-P	BJN100-NDT-P
Power supply	12-24VDC ±10% (Ripple P-P : Max.10%)		
Current consumption	Max. 30mA		
Min. diameter of transmitting SPOT	Approx. φ 2.0mm	Approx. φ 2.5mm	
Min. sensing target	Approx. min. φ 0.2mm (Copper wire)		
Sensing target	Transparent, Translucent, Opaque materials		
Sensing distance	30~70mm (100×100mm Non-glossy white paper)	70~130mm (100×100mm Non-glossy white paper)	
Hysteresis	Max. 25% at sensing distance	Max. 20% at sensing distance	
Light source / Wavelength	Pin Point LED(Point source) / 650nm		
Control output	NPN or PNP Open collector type • Load voltage : Max. 26.4VDC • Load current : Max. 100mA • Residual voltage ⇨ NPN : Max. 1V, PNP : Min. (Power voltage -2.5V)		
Operation mode	Light ON / Dark ON selectable (Short rotator adjuster)		
Protection circuit	Reverse polarity protection, Output short-circuit protection, Interference prevention function		
Response time	Max. 1ms		
Sensitivity adjustment	Short rotator adjuster(210°)		
Ambient illumination	Sunlight:Max. 11,000lx, Incandescent lamp:Max. 3,000lx (Receiver illumination)		
Ambient temperature	Operation:-25~55°C, Storage:-40~70°C (at non-freezing, non-dew status)		
Ambient humidity	Operation & Storage : 35~85%RH (at non-dew status)		
Insulation resistance	Min. 20MΩ (500VDC)		
Dielectric strength	1,000VAC 50/60Hz for 1minute		
Vibration	1.5mm or 300mm amplitude at frequency of 10~55Hz in each of X, Y, Z directions for 2 hours		
Shock	500m/s ² X, Y, Z directions for 3 times		
Protection	IP65 (IEC standard)		
Connection	Outgoing cable type		
Indicator	Operation indicator : Red, Stability indicator : Green		
Material	Case : PC+ABS, Lens : PMMA, LED CAP : PC		
Cable	φ 3.5mm, 3P, Length : 2m		
Accessory	Mounting bracket, Bolt, Adjustment driver		
Unit weight	Approx. 45g		

Control output diagram

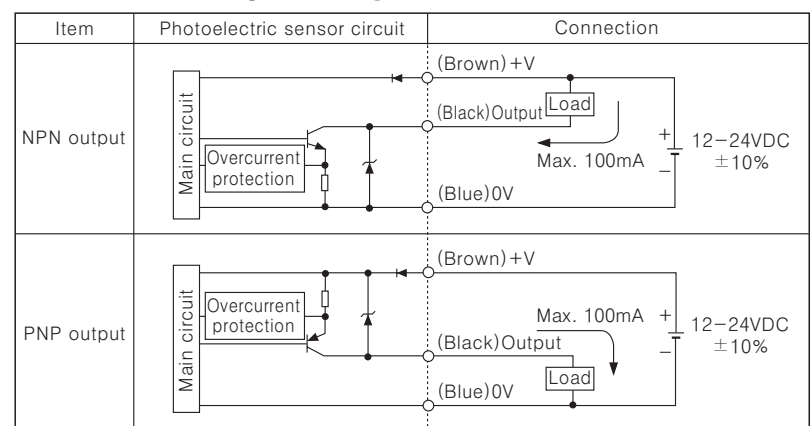

Connections

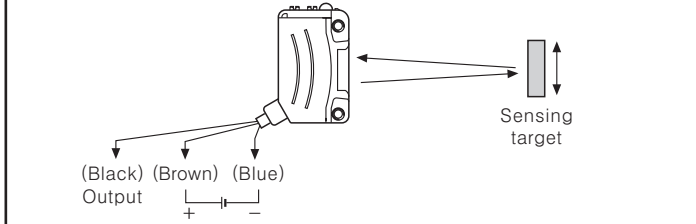

Operation mode

Operation mode	Light ON mode	Dark ON mode
Receiver	Received light Interrupted light	
Operation indicator (Red LED)	ON OFF	
TR Output	ON OFF	

Operation mode and timing diagram

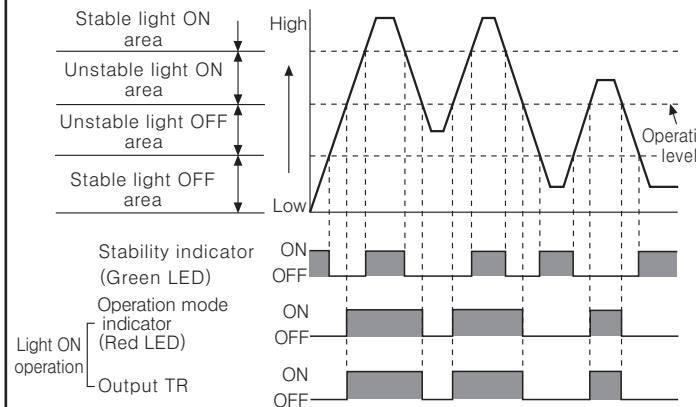

*The waveform of "Operation mode indicator" and "Output TR" is for Light ON mode, it is operated as reverse in Dark ON mode.

Mounting and sensitivity adjustment

For mounting
Please use screw M3 for mounting of sensor, set the tightening torque under 0.5N.m.

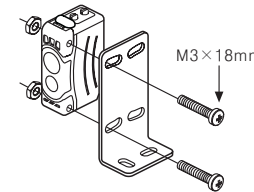

Switching of operation mode

Light ON mode (Light ON)		Turn the operation switching adjuster to right (L direction), it is set as Light ON mode.
Dark ON mode (Dark ON)		Turn the operation switching adjuster to left (D direction), it is set as Dark ON mode.

Optical axis adjustment

After place a sensing target, fix it in the middle of position where the indicator is operated adjusting the sensor to up • down, left • right.

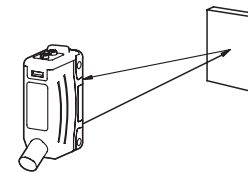

Object (Copper wire) detection

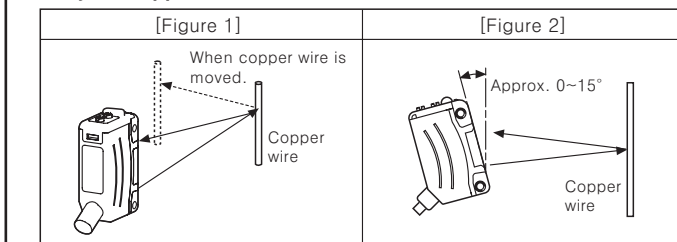

*Mount sensor slanted at an angle ranged 0~15° shown above as [Figure 2] for stable detection to detect as shown in [Figure 1].

Sensitivity adjustment

Order	Sensitivity adjuster	Description
1		Turn the sensitivity adjuster to the right of min. and check position (A) where the indicator is turned on in "Light ON status".
2		Turn the sensitivity adjuster more to the right of position (A), check position (B) where the indicator is turned on. And turn the adjuster to the left, check position (C) where the indicator is turned off in "Dark ON status". *If the indicator is not lighted although the adjuster is turned to the max. position, the max. position is (C).
3		Set the adjuster at the center of (A) and (C). To set the optimum sensitivity, check the operation and lighting of stable indicator with sensing target or without it. If the indicator is not lighted, please check the sensing method again because sensitivity is unstable.

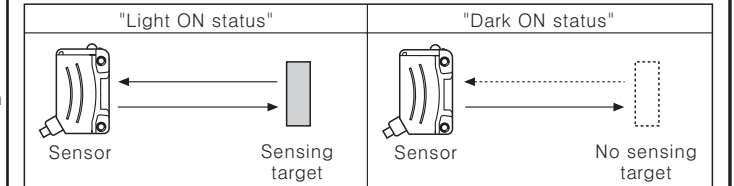

*Please set adjuster as sensitivity adjustment is executed in stable Light ON area and the reliability of environment (temperature, supply, dust etc) is increased after the mounting it in a stable area.
*Do not apply an excessive force on adjuster, it can be broken.

Caution for using

- The sensor will be in a detectable status within 500ms after supply the power. If the power line of the load and the sensor is different, supply power voltage to the sensor first.
- Shade a strong source of light as like sunlight, spotlight not to be let in the inclination angle range of photoelectric sensor directly.
- The photoelectric sensor may cause malfunction under the fluorescent lamp light, be sure to use the cover or the shutter to shade the light.
- If photoelectric sensor is installed at flat part, it may cause malfunction by reflection light from flat part. Be sure to put space between photoelectric sensor and ground.
- When wiring the photoelectric sensor with high voltage line, power line in a same conduit, it may cause malfunction or mechanical problem, please do wire separately or use different conduit.
- Avoid install the unit in place with corrosive gas, oil or dust, strong flux, noise, sunlight, strong alkali and acid.
- In case of connecting relay as inductive load to output, please remove surge by using diode or varistor.
- Photoelectric sensor cable shall be used as short as possible, because it may cause malfunction by noise through the cable.
- When it is stained by dirt at lens, please clean the lens with dry cloth, do not use an organic materials such as alkali, acid and chromic acid.
- When use switching power supply as the source of supplying power, F.G terminal shall be grounded and a condenser for removing noise shall be installed between 0V and F.G terminal.

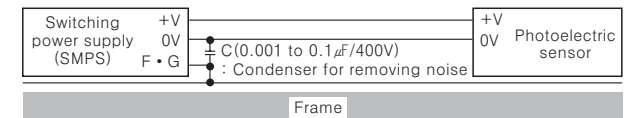

*It may cause malfunction if above instructions are not followed.

Major products

- PROXIMITY SENSOR
- PHOTOELECTRIC SENSOR
- AREA SENSOR
- FIBER OPTIC SENSOR
- DOOR/DOOR SIDE SENSOR
- PRESSURE SENSOR
- ROTARY ENCODER
- SENSOR CONTROLLER
- SWITCHING POWER SUPPLY
- TEMPERATURE CONTROLLER
- TEMPERATURE/HUMIDITY TRANSDUCER
- POWER CONTROLLER
- RECORDER
- TACHOMETER/PULSE(RATE) METER
- METER METER
- INDICATOR
- SIGNAL CONVERTER
- COUNTER
- TIMER
- DISPLAY UNIT
- GRAPHIC PANEL
- STEPPING MOTOR & DRIVER
- MOTION CONTROLLER

Autonics Corporation
http://www.autonics.com

Satisfiable Partner For Factory Automation

HEAD QUARTERS
41-5, Yongdang-dong, Yangsan-si, Gyeongsang, 626-847, Korea

OVERSEAS SALES
Bldg. 402 3rd Fl., Bucheon Techno Park, 193, Yakdean-dong, Wonmi-gu, Bucheon-si, Gyeonggi-do, 420-734, Korea
TEL: 82-32-610-2730 / FAX: 82-32-329-0728
E-mail: sales@autonics.com

The proposal of a product improvement and development : Product@autonics.com

Ordering information

BJN 50 - NDT - P	
N	NPN open collector output
P	PNP open collector output
T	Solid-state output (Transistor)
D	DC power
N	Narrow beam reflective type
Number	Sensing distance (mm)
N	Micro spot
BJ	Series name

*The above specifications are subject to change without notice.