

# Autonics FIBER OPTIC SENSOR BF4 SERIES

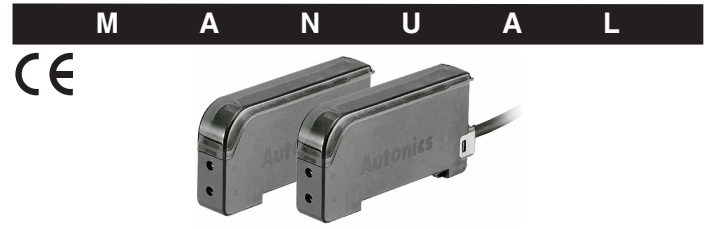

Thank you very much for selecting Autonics products.  
For your safety, please read the following before using.

## Caution for your safety

- Please keep these instructions and review them before using this unit.
- Please observe the cautions that follow:
- Warning** Serious injury may result if instructions are not followed.
- Caution** Product may be damaged, or injury may result if instructions are not followed.
- The following is an explanation of the symbols used in the operation manual.
- Caution: Injury or danger may occur under special conditions.

## Warning

- In case of using this unit with machineries (Nuclear power control, medical equipment, vehicle, train, airplane, combustion apparatus, entertainment or safety device etc.), it requires installing fail-safe device, or contact us for information on type required. It may result in serious damage, fire or human injury.
- Do not disassemble and modify this unit, when it requires. If needs, please contact us. It may give an electric shock and cause a fire.

## Caution

- This unit shall not be used outdoors. It might shorten the life cycle of the product or give an electric shock.
- Do not use this unit in place where there is flammable or explosive gas. It may cause a fire or explosion.
- Please observe voltage rating and do not supply AC power. It may result in damage to this unit.
- Please check the polarity of power and wrong wiring. It may result in damage to this unit.
- Do not use this unit in place where there is vibration or impact. It may result in damage to this unit.
- In cleaning the unit, do not use water or an oil-based detergent. It might cause an electric shock or fire that will result in damage to the product.

## Part names

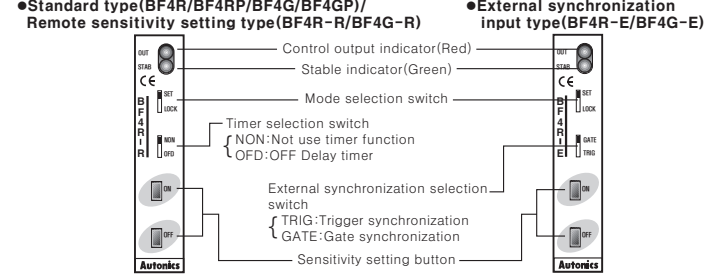

## Function

### Sensitivity adjustment

#### Adjustment by the sensitivity setting button (All models)

- Mount the fiber optic cable within detecting distance.
  - Change the mode selection switch to Set.
  - Press ON button in state of installed the detecting target. (Press ON button without the detecting target for the through-beam type)
  - The stable indicator flickers at ON state. (Check the target position)
  - Press OFF button in state of removed detecting target. (Press OFF button at state of installed the detecting target for the through-beam type)
- When there is enough sensitivity difference between ON state and OFF state, the STAB indicator flickers one time only at stable sensing area. When there is not enough sensitivity difference between ON state and OFF state, the STAB indicator flickers five times at unstable sensing area. (Note)

Change the mode selection switch to LOCK, even though somebody touches the sensitivity setting button, setting sensitivity shall not be changed.

(Note) The sensitivity can be set at unstable detecting area.

  - Setting sensitivity is memorized when power turns off.
  - Do not touch the fiber optic cable after adjusting the sensitivity.

### Dark ON Mode (Diffuse reflective type)

- Most of adjustments except ③ and ⑤ are same as Light ON mode.
- Press ON button without the detecting target. (③ state)
- Press OFF button with the detecting target. (⑤ state)
- Light ON mode: The control output turns on at state (Received light) and turns off at state (Interrupted light).
- Dark ON mode: The control output turns off at state (Received light) and turns on at state (Interrupted light).

### In case of setting as max. sensitivity

- Set the mode selection switch to SET mode.
- In case of Light ON mode: Press ON/OFF button from ON to OFF without the detecting target. (Or set ON input for remote sensitivity setting to Low level, and then set OFF input for remote sensitivity setting to Low level)
- In case of Dark ON mode: Press ON/OFF button from OFF to ON without the detecting target. (Or set OFF input for remote sensitivity setting to Low level, and then set ON input for remote sensitivity setting to Low level)
- Set the mode selection switch to LOCK mode.

### Application

- In case of extend detecting distance as the diffuse reflection type.
- In case of use the through-beam type at bad environment.

### Remote adjustment of sensitivity (BF4R-R/BF4G-R only)

- BF4R-R/BF4G-R type can adjust the sensitivity with input signal times in regardless to the mode selection switch as follow diagram:
- Adjustment at Light ON Mode**
- SW1 (ON input of remote sensitivity setting): SW1 turns on and then turns off instead of ③ method by the sensitivity setting button.
  - SW2 (OFF input of remote sensitivity setting): SW2 turns on and then turns off instead of ⑤ method by the sensitivity setting button.
- Adjustment at Dark ON Mode**
- SW2 (OFF input of remote sensitivity setting): SW2 turns on and then turns off instead of ⑤ method by the sensitivity setting button.
  - SW1 (ON input of remote sensitivity setting): SW1 turns on and then turns off instead of ③ method by the sensitivity setting button.

### Answer Back function (BF4R-R/BF4G-R only)

- When ON or OFF input of remote sensitivity setting is applied, after 300ms, self-diagnosis output turns on for 40ms and then the sensor keeps normal detecting state. (Note: Time chart)
- Self-diagnosis output does not turn on if there is no difference of sensitivity between ON input and OFF input and stable sensing is not excited, but stable sensing operates after 340ms.
- (Time Chart: Light ON Mode)

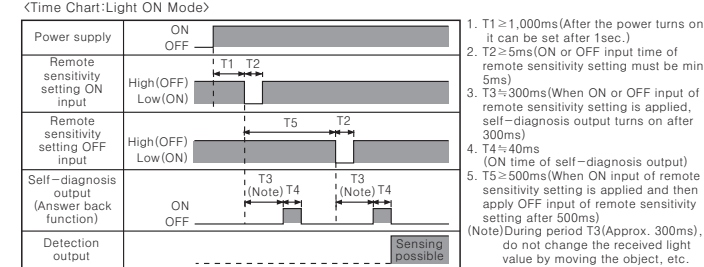

### Interference prevention function (All models)

- BF4 series have a built-in interference prevention function, two fiber optic cables can be mounted very closely by setting different emission frequencies.
- Interference prevention function (Operation of dual frequency mode)**

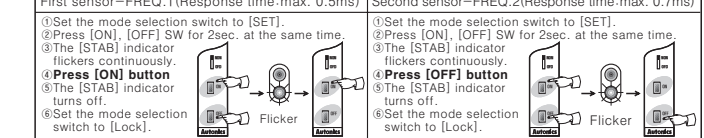

### Interference prevention function (Operation of normal mode) - Response time: Max. 0.5ms

- Set the mode selection switch to [Set].
- Press [ON], [OFF] SW for 2sec. at the same time.
- The [STAB] indicator flickers continuously.
- Press [ON] button
- The [STAB] indicator turns off.
- Set the mode selection switch to [Lock].

### Interference prevention function (Operation of normal mode) - Response time: Max. 0.7ms

- Set the mode selection switch to [Set].
  - Press [ON], [OFF] buttons for 2 sec. at the same time.
  - The [STAB] indicator flickers continuously.
  - Press [ON], [OFF] buttons at the same time.
  - The [STAB] indicator turns off.
  - Set the mode selection switch to [Lock].
- In case of using interference prevention function, hysteresis & response time will be longer than normal operation.
- The above specifications are changeable without notice anytime.**

## Specifications

Type	Standard type	External synchroni-zation input type	Remote sensitivity setting type	Standard type
Model	BF4R	BF4R-E	BF4R-R	BF4RP
	BF4G	BF4G-E	BF4G-R	BF4GP
Power voltage	12~24VDC ±10%, Ripple p-p: Max. 10%			
Current consumption	Max. 45mA			
Control output	NPN O · C output		PNP O · C output	
	Applied voltage: Max. 30VDC, Load current: Max. 100mA Residual voltage: Max. 1V (at 100mA load current), Max. 0.4V (at 16mA load current)		Applied voltage: Max. 30VDC Load current: Max. 100mA Output voltage: Min. power supply - 2.5V	
Self-diagnosis output	ON state under unstable sensing (When the target stays for 300ms in unstable area) or ON state when control output short-circuited		ON state under unstable sensing (When the target stays for 300ms in unstable area) or ON state when control output short-circuited	
	Applied voltage: Max. 30VDC, Load current: Max. 50mA Residual voltage: Max. 1V (at 50mA load current), Max. 0.4V (at 16mA load current)		Applied voltage: Max. 30VDC Load current: Max. 50mA Output voltage: Min. power supply - 2.5V	
Operation mode	Selectable the sensitivity in front of this unit with ON/OFF button			
Protection circuit	Short-circuit protection, Reverse polarity protection circuit			
Light source	Red LED/Green LED (Modulated)			
Response time	Max. 0.5ms (Note 1)			
Control output indication (OUT)	Red LED			
Stable indication (STAB)	Green LED flickers when the target stays in stable sensing area			
Emission disable input function	Built in			
External synchroni-zation function	Built in (Gate/Trigger)			
Remote sensitivity setting function	Built in			
Interference prevention function	Built-in selectable FREQ.1 or FREQ.2 by ON/OFF button (Note 1)			
Timer function (Selectable)	OFF delay timer (Approx. 40ms fixed)	OFF delay timer (Approx. 40ms fixed)		
Ambient illumination	Sunlight : Max. 11,000lx, Incandescent lamp : Max. 3,000lx			
Noise strength	±240V the square wave noise (pulse width: 1μs) by the noise simulator			
Dielectric strength	1,000VAC 50/60Hz for 1 minute			
Insulation resistance	Min. 20MΩ (at 500VDC)			
Vibration	1.5mm amplitude at frequency of 10 to 55Hz in each of X, Y, Z directions for 2 hours			
Shock	500m/s <sup>2</sup> (50G) X, Y, Z direction for 3 times			
Operating temperature	-10 to 50°C (at non-freezing state)			
Storage temperature	-20 to 70°C			
Ambient humidity	35 to 85%RH			
Material	Case : Heat-resistant ABS, Case cover : Polycarbonate			
Cable	φ4, 4P, Length: 2m		φ4, 6P, Length: 2m	
Weight	Approx. 65g			
	*(Note1) Frequency 1 (Normal mode): Max. 0.5ms, Frequency 2: Max. 0.7ms			

## Control output circuit diagram

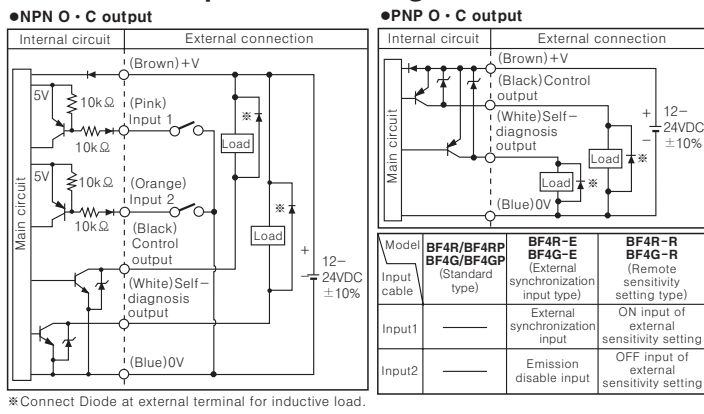

## Dimensions

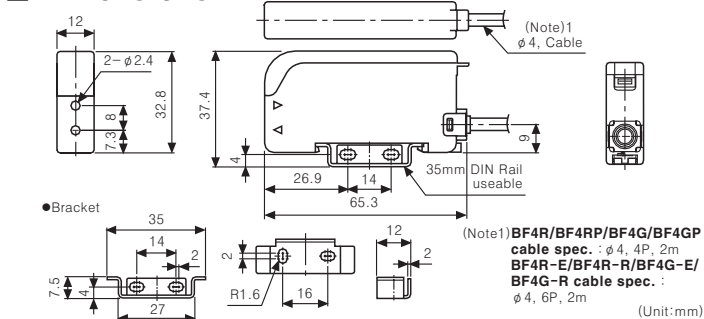

## Self-diagnosis function (All models)

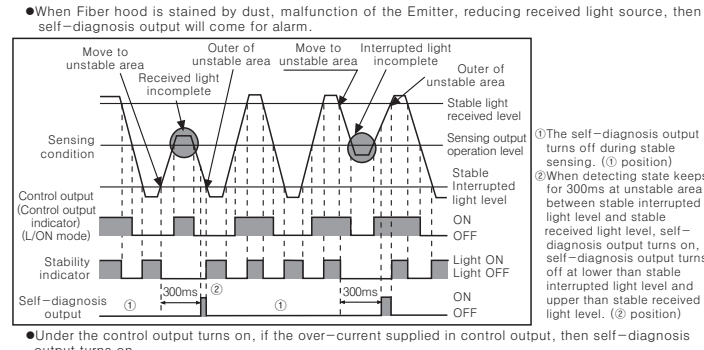

## OFF Delay timer function (BF4R/BF4G/BF4RP/BF4GP/BF4R-R/BF4G-R only)

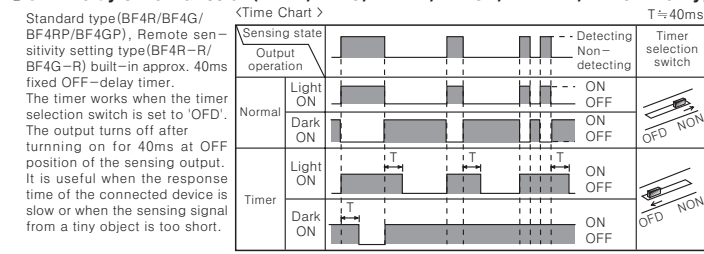

## External synchronization input function (BF4R-E/BF4G-E only)

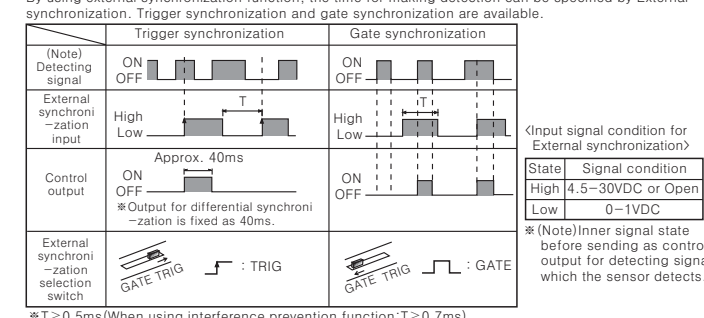

## Emission disable function (BF4R-E/BF4G-E only) - Operation Test

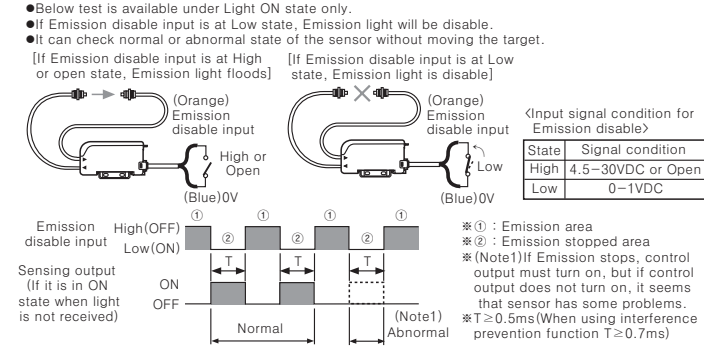

## Connection

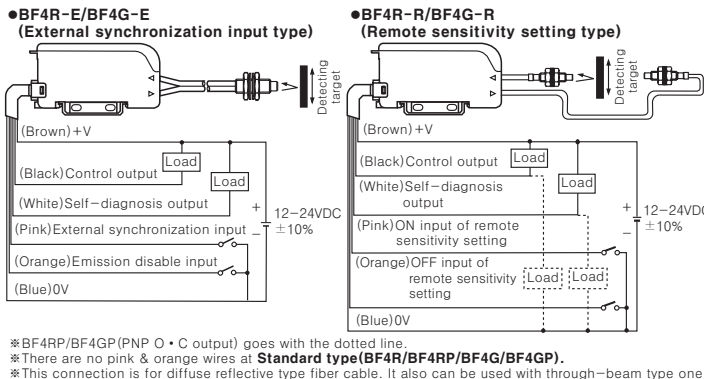

- BF4RP/BF4GP (PNP O · C output) goes with the dotted line.
- There are no pink & orange wires at Standard type (BF4R/BF4RP/BF4G/BF4GP).
- This connection is for diffuse reflective type fiber cable. It also can be used with through-beam type one.

## Mounting

- Amplifier**
  - When mounting the Amp.
    - Hook the amp on the front of DIN Rail (or Bracket).
    - Press the rear part of the amp on DIN Rail (or Bracket).
  - In case of separating Amp Push the back of Amp toward ③ and lift the hole for fiber toward ④ up then simply take it out without tools.
- Installation of fiber optic cable**
  - In case of using L bracket
    - Insert the fiber optic cable into the L Bracket.
    - Tightening torque: Max. 2kgf · cm
  - In case of screw
    - Insert the fiber optic cable into the screw.
    - Tightening torque: Max. 2kgf · cm
- Connection of fiber optic cable & Amp.**
  - Open the Lock lever to 'V' direction.
  - Insert the fiber optic cable into the Amp. slowly. (Depth: 1.0mm)
  - Close the Lock lever to 'V' direction.

## Mode setting

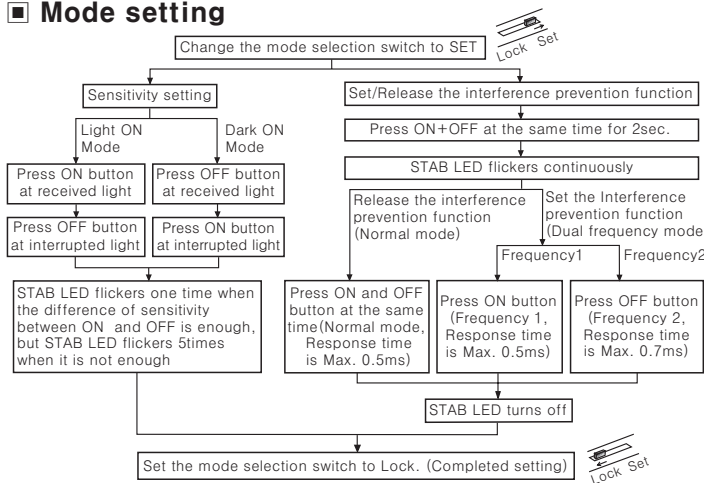

## Fiber optic cable model

Detecting type	Model	Allowable band radius	Min. detecting object	Detecting distance (mm)	Dimension
Through-beam type	FT-320-05	15R	φ0.5	150	Adapter 12, 2000
	FT-420-10	30R	φ1	500	Adapter 12, 2000
Diffuse reflective type	FD-320-05	15R	φ0.03	40	Adapter 12, 2000
	FD-620-10	30R	φ0.03	120	Adapter 12, 2000

## Specification (Example)

Model	Dimension	Features
FTH-310	φ6, 12, 1000, φ4.6, φ3	Fiber optic cable protection pipe (Shock, Vibration, Cable cut)
FTH-410	φ7, 12, 1000, φ5.8, φ4	
FDH-610	φ9, 11, 1000, φ7, φ5.5	

## Accessories

Model	Dimension	Features
FTH-310	φ6, 12, 1000, φ4.6, φ3	Fiber optic cable protection pipe (Shock, Vibration, Cable cut)
FTH-410	φ7, 12, 1000, φ5.8, φ4	
FDH-610	φ9, 11, 1000, φ7, φ5.5	

## Caution for using

- Do not scratch the section of fiber optic cable.
  - Intercept a strong source of light as like sunlight, spotlight within inclination angle range of photoelectric sensor.
  - Do not apply a strong tensile force to fiber optic cable.
  - In case of installing the fiber optic cable, be sure not to curve the fiber optic cable over tolerance that mentioned in our catalog.
  - When wire the photoelectric sensor with high voltage line, power line in the same conduit, it may cause malfunction or mechanical trouble. Therefore please wire separately or use different conduit.
  - Avoid installing the unit as following place.
    - Corrosive gas, oil or dust, strong flux, noise, sunlight, strong alkali, acid.
    - In case of connecting inductive load such as DC relay at load, use shielded cable, diode and varistor in order to remove noise.
  - The amp. cable shall be used shortly, because it might cause malfunction by noise through the cable.
  - When it is stained by dirt at a detecting part of the fiber optic cable, please clean the detecting part with dry cloth softly. But don't use an organic materials such as alkali, acid, chromic acid.
  - When the unit is supplied by switching power supply unit, as a power source, please earth Frame Ground (F.G) terminal, and connect condenser for removing noise.
- It may cause malfunction if above instructions are not followed.**

## Main products

- COUNTER
- TIMER
- TEMPERATURE CONTROLLER
- PANEL METER
- TACHO/LINE SPEED/PULSE METER
- DISPLAY UNIT
- PROXIMITY SENSOR
- PHOTOELECTRIC SENSOR
- FIBER OPTIC SENSOR
- PRESSURE SENSOR
- ROTARY ENCODER
- SENSOR CONTROLLER
- POWER CONTROLLER
- STEPPING MOTOR & DRIVER & CONTROLLER
- LASER MARKING SYSTEM (CO<sub>2</sub>, Nd:YAG)

**Autonics Corporation**  
http://www.autonics.com

**Satisfiable Partner For Factory Automation**

**HEADQUARTERS:**  
41-5, Yongdang-ri, Ulsung-eup, Yongsan-si, Gyeongnam, 626-847, Korea

**INTERNATIONAL SALES:**  
Bldg. 402 3rd Fl., Bucheon Techno Park, 193, Yakdae-dong, Wonmi-gu, Bucheon-si, Gyeonggi-do, 420-734, Korea  
TEL: 82-32-610-2730 / FAX: 82-32-329-0728  
E-mail: sales@autonics.net

EP-KE-08-0240G