

PowerFlex Digital DC Drive

Technical Data



Allen-Bradley

efesotomasyon.com



efesotomasyon.com

LISTEN.
THINK.
SOLVE.®

Product Description

The PowerFlex Digital DC drive provides digital control for precise speed and current regulation, easy programmability, extensive diagnostics, non-regenerative and regenerative operation, and is easily interfaced for integration into larger drive systems. PowerFlex DC drives are well suited to a variety of applications including extruding operations, finishing, drawing, and coating processes, applications exhibiting shock loads, high inertia, rapid accel/decel or continuous regeneration, and is an excellent choice for existing DC machinery upgrades. The compact design of this drive includes a fully contained power module and a common control structure for the entire range of horsepower. And, to make connectivity even easier, the PowerFlex DC drive provides a standard DPI interface that is compatible with all PowerFlex DPI communication products.

The standard hardware offering consists of an open type enclosure, armature converter, regulated field converter for field weakening or economy applications, an advanced regulator with integrated DPI functionality, DC tachometer and encoder capability.

Table of Contents

<u>Description</u>	<u>Page</u>
Standard Drives Program	4
Catalog Number Explanation	6
Standard Drives Product Selection	7
Factory Installed Options	9
User Installed Options	9
Installation Considerations	17
Circuit Protection	47
Mounting	60
Approximate Dimensions	61
Parameter List	67
PowerFlex DC Configured Drives	72
Specifications	77
Watts Loss	80
Reference Materials	82



Standard Drives Program



Packaging and Mounting

- **IP20, Nema/UL Type Open** - For conventional mounting inside or outside a control cabinet.

Easy to Use Communication Tools

The PowerFlex Digital DC drive provides common communication tools that are familiar and easy to use, including the LCD Human Interface Module (HIM) and PC-based configuration tools.

- The LCD HIM provides:
 - Large and easy to read 7 line x 21 character, backlit display
 - Alternate function keys for shortcuts to common tasks
 - “Calculator-like” number pad for fast and easy data entry (Full Numeric version only)
 - Control keys for local start, stop, speed, and direction
 - Remote versions for panel mount applications
- PC-based Configuration tools include:
 - DriveExplorer™ and DriveExplorer Lite (v5.02 or higher). A simple and flexible “On-line” tool for monitoring and configuring while connected to a drive.
 - DriveTools™ SP (v4.01 or higher is required with a PowerFlex DC drive specific software patch. The patch can be downloaded from <http://www.ab.com/support/abdrives/webupdate/>). A suite of software tools which provide an intuitive means for programming, troubleshooting and maintaining Allen-Bradley drives, including the PowerFlex DC Drive Start-Up Wizard.
- Internal Communications allow you to integrate the drive into the manufacturing process. Status indicators for all internal communication options are visible on the cover for easy setup and monitoring of drive communications. You can easily manage information from “shop floor to top floor” and seamlessly integrate a complete system as you control, configure and collect data.

Drive Features

- Fast-acting **Current Limit** and **Voltage Regulation** result in maximum accel/decel without tripping.
- **High speed analog inputs** improve drive response to torque or speed commands.
- **Programming flexibility** allows parameters to be linked within the drive.
- **Field flashable firmware** through DPI interface.
- **Flying Start** delivers smooth and instantaneous connection into rotating loads, regardless of commanded direction, without the need for any speed feedback.
- **Single Phase Regulated Field supply** (10, 14, & 20A) standard on all frames.
- **Integral Process PI Control** can eliminate the need for a separate process loop controller.
- **Speed Regulation** - Open Loop or Closed Loop
 - Armature Feedback provides a 2000:1 rpm speed range
 - DC Tachometer Feedback provides up to 0.1% speed regulation
 - Encoder Feedback provides up to 0.1% speed regulation for the tightest application requirements.
- **Torque Regulation** - Open Loop or Closed Loop
 - Open Loop torque regulation provides $\pm 5\%$ regulation.
 - Encoder Feedback provides $\pm 2\%$ regulation and the ability to hold full load at zero speed.

Unsurpassed Capability in Network Communications

PowerFlex drives are fully compatible with the wide variety of Allen-Bradley DPI™ communication adapters, offering the following benefits:

ControlNet™	DeviceNet™	EtherNet/IP™	Interbus™	PROFIBUS™	Remote I/O	RS485 DF1	Description
✓	✓	✓					(Unconnected Messaging) permits other network devices (e.g. PanelView™) to communicate directly to a drive without routing the communication through the network scanner.
✓	✓	✓				✓	Adapter Routing - Plug PC into one drive and talk to all other Allen-Bradley drives on same network, without being routed through network scanner.
✓	✓	✓	✓	✓	✓	✓	Access to 100% of all parameters over the network.
	✓	✓	✓				AutoBaud capability makes initial connections less problematic.
	✓						Change of State significantly reduces network traffic by configuring control messages to be sent only upon customer defined states. Very flexible configuration for each node (Example: "reference must change by more than 5%").
	✓	✓					Peer Control provides master-slave type control between drives, where one or more slave drives (consumers) can run based on the status of a master drive (producer), which can also significantly reduce network traffic.
	✓						ADR (Automatic Device Replacement) saves significant time and effort when replacing a drive, by allowing the scanner to be configured to automatically detect a new drive and download the required parameter settings.
✓	✓	✓	✓	✓	✓	✓	Flexible Fault Configuration - Adapters can be programmed to take fault based actions as ramp to stop, coast-to-stop and hold last state, as well as send user configurable logic control and speed reference values. In addition, different actions can be taken based on whether the network experienced a serious problem (broken cable etc.) versus network idle condition (PLC set to "Program").

Catalog Number Explanation

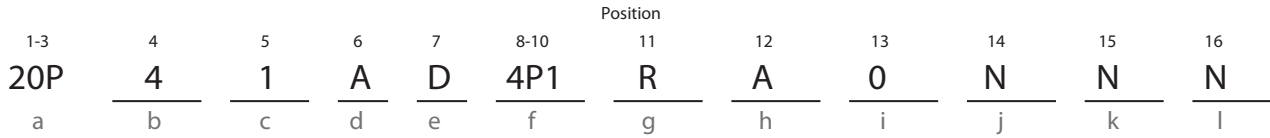

a

Drive	
Code	Type
20P	PowerFlex DC

b

Motor Operation	
Code	Type
2	Two Quadrant Operation *
4	Four Quadrant Operation

* Not available for 230V AC input drives.

c

Input Type	
Code	Type
1	6 Pulse

d

Enclosure		
Code	Enclosure Rating	Conform. Coat
A	IP20, NEMA/UL Type Open	No

e

Input Voltage	
Code	Voltage
B	230V AC
D	460V AC *
E	600V AC
F	690V AC

* Use this code for 400V AC input applications.

f1

230V, 60 Hz Input				
Code	Hp	Armature Amps	Frame	Field Amps
7P0	1.5	7	A	10
9P0	2	9	A	10
012	3	12	A	10
020	5	20	A	10
029	7.5	29	A	10
038	10	38	A	10
055	15	55	A	10
073	20	73	A	14
093	25	93	A	14
110	30	110	A	14
146	40	146	B	20
180	50	180	B	20
218	60	218	B	20
265	75	265	B	20
360	100	360	B	20
434	125	434	B	20
521	150	521	C	20
700	200	700	C	20
875	250	875	D	40
1K0	300	1050	D	40

f2

460V, 60 Hz Input				
Code	Hp	Armature Amps	Frame	Field Amps
4P1	2	4.1	A	10
6P0	3	6	A	10
010	5	10	A	10
014	7.5	14	A	10
019	10	19	A	10
027	15	27	A	10
035	20	35	A	10
045	25	45	A	10
052	30	52	A	10
073	40	73	A	14
086	50	86	A	14
100	60	100	A	14
129	75	129	A	14
167	100	167	B	20
207	125	207	B	20
250	150	250	B	20
330	200	330	B	20
412	250	412	B	20
495	300	495	C	20
667	400	667	C	20
830	500	830	D	40
996	600	996	D	40
1K1	700	1162	D	70
1K3	800	1328	D	70
1K4	900	1494	D	70

f3 *

575V, 60 Hz Input				
Code	Hp	Armature Amps	Frame	Field Amps
067	50	67.5	B	20
101	75	101.3	B	20
135	100	135	B	20
270	200	270	B	20
405	300	405	B	20
540	400	504	C	20
675	500	675	C	20
810	600	810	D	40
1K0	800	1080	D	40
1K2	900	1215	D	40
1K3	1000	1350	D	40
1K6	1250	1668	D	40

* Frame B & C drives not yet available at this input rating. Consult with factory for availability.

f4 *

690V, 60 Hz Input				
Code	Hp	Armature Amps	Frame	Field Amps
452	400	452	C	20
565	500	565	C	20
678	600	678	D	40
791	700	791	D	40
904	800	904	D	40
1K0	900	1017	D	40
1K1	1000	1130	D	70
1K2	1100	1243	D	70
1K4	1250	1413	D	70
1K5	1400	1582	D	70

* Frame C drives not yet available at this input rating. Consult with factory for availability.

Catalog Number Explanation, Continued

1-3	4	5	6	7	8-10	Position 11	12	13	14	15	16
20P	4	1	A	D	4P1	R	A	0	N	N	N
a	b	c	d	e	f	g	h	i	j	k	l

g

Field Supply	
Code	Type
R	Single-Phase Regulated

h

Packaging/Documentation		
Code	Shipping Carton	User Manual
A	Yes	Yes

i

HIM	
Code	Operator Interface
0	Blank Cover *

* Standard - for additional selections, refer to the PowerFlex Digital DC Drive Technical Data, publication 20P-TD001...

j

I/O Options *	
Code	Control
A	I/O Expansion Card (4 Additional 24V dc Digital Inputs & Outputs, 2 Analog Outputs)
B	115V ac Conversion Card (8 Digital Inputs & Outputs)
C	I/O Expansion Card + 115V ac Conversion
N	None (8 - 24V dc Digital Inputs & Outputs, 3 Analog Outputs and 2 Analog Inputs are Standard)

* All I/O Options are purchased separately and are user installed.

k

Communication Options	
Code	Description
N	None *

* Standard - for additional selections, refer to the PowerFlex Digital DC Drive Technical Data, publication 20P-TD001...

l

Cabinet Options	
Code	Type
N	None

Standard Drives Product Selection

IP20, NEMA/UL Type Open (Position d = A)

All drives are rated 150% overload for 60 seconds, 200% for three seconds.

230V AC, Three-Phase

Drive Output Rating			Non-Regenerative Drives ⁽¹⁾	Regenerative Drives	Frame Size
Normal Duty kW	Normal Duty HP	Amps	Cat. No.	Cat. No.	
1.2	1.5	7	20P21AB7P0RA0NNN	20P41AB7P0RA0NNN	A
1.5	2	9	20P21AB9P0RA0NNN	20P41AB9P0RA0NNN	A
2.2	3	12	20P21AB012RA0NNN	20P41AB012RA0NNN	A
3.7	5	20	20P21AB020RA0NNN	20P41AB020RA0NNN	A
5.5	7.5	29	20P21AB029RA0NNN	20P41AB029RA0NNN	A
7.5	10	38	20P21AB038RA0NNN	20P41AB038RA0NNN	A
11	15	55	20P21AB055RA0NNN	20P41AB055RA0NNN	A
15	20	73	20P21AB073RA0NNN	20P41AB073RA0NNN	A
18.5	25	93	20P21AB093RA0NNN	20P41AB093RA0NNN	A
22	30	110	20P21AB110RA0NNN	20P41AB110RA0NNN	A
30	40	146	20P21AB146RA0NNN	20P41AB146RA0NNN	B
37	50	180	20P21AB180RA0NNN	20P41AB180RA0NNN	B
45	60	218	20P21AB218RA0NNN	20P41AB218RA0NNN	B
56	75	265	20P21AB265RA0NNN	20P41AB265RA0NNN	B

Drive Output Rating			Non-Regenerative Drives ⁽¹⁾	Regenerative Drives	Frame Size
Normal Duty kW	Normal Duty HP	Amps	Cat. No.	Cat. No.	
75	100	360	20P21AB360RA0NNN	20P41AB360RA0NNN	B
93	125	434	20P21AB434RA0NNN	20P41AB434RA0NNN	B
112	150	521	20P21AB521RA0NNN	20P41AB521RA0NNN	C
149	200	700	20P21AB700RA0NNN	20P41AB700RA0NNN	C
186	250	875	20P21AB875RA0NNN	20P41AB875RA0NNN	D
224	300	1050	20P21AB1K0RA0NNN	20P41AB1K0RA0NNN	D

(1) Currently not available or sale.

460V AC, Three-Phase

Drive Output Rating			Non-Regenerative Drives	Regenerative Drives	Frame Size
Normal Duty kW	Normal Duty HP	Amps	Cat. No.	Cat. No.	
1.5	2	4.1	20P21AD4P1RA0NNN	20P41AD4P1RA0NNN	A
2.2	3	6	20P21AD6P0RA0NNN	20P41AD6P0RA0NNN	A
3.7	5	10	20P21AD010RA0NNN	20P41AD010RA0NNN	A
5.5	7.5	14	20P21AD014RA0NNN	20P41AD014RA0NNN	A
7.5	10	19	20P21AD019RA0NNN	20P41AD019RA0NNN	A
11	15	27	20P21AD027RA0NNN	20P41AD027RA0NNN	A
15	20	35	20P21AD035RA0NNN	20P41AD035RA0NNN	A
18.5	25	45	20P21AD045RA0NNN	20P41AD045RA0NNN	A
22	30	52	20P21AD052RA0NNN	20P41AD052RA0NNN	A
30	40	73	20P21AD073RA0NNN	20P41AD073RA0NNN	A
37	50	86	20P21AD086RA0NNN	20P41AD086RA0NNN	A
45	60	100	20P21AD100RA0NNN	20P41AD100RA0NNN	A
56	75	129	20P21AD129RA0NNN	20P41AD129RA0NNN	A
75	100	167	20P21AD167RA0NNN	20P41AD167RA0NNN	B
93	125	207	20P21AD207RA0NNN	20P41AD207RA0NNN	B
112	150	250	20P21AD250RA0NNN	20P41AD250RA0NNN	B
149	200	330	20P21AD330RA0NNN	20P41AD330RA0NNN	B
187	250	412	20P21AD412RA0NNN	20P41AD412RA0NNN	B
224	300	495	20P21AD495RA0NNN	20P41AD495RA0NNN	C
298	400	667	20P21AD667RA0NNN	20P41AD667RA0NNN	C
373	500	830	20P21AD830RA0NNN	20P41AD830RA0NNN	D
447	600	996	20P21AD996RA0NNN	20P41AD996RA0NNN	D
552	700	1162	20P21AD1K1RA0NNN	20P41AD1K1RA0NNN	D
597	800	1328	20P21AD1K3RA0NNN	20P41AD1K3RA0NNN	D
671	900	1494	20P21AD1K4RA0NNN	20P41AD1K4RA0NNN	D

575V AC, Three-Phase

Drive Output Rating			Non-Regenerative Drives	Regenerative Drives	Frame Size
Normal Duty kW	Normal Duty HP	Amps	Cat. No.	Cat. No.	
447	600	810	20P21AE810RA0NNN	20P41AE810RA0NNN	D
597	800	1080	20P21AE1K0RA0NNN	20P41AE1K0RA0NNN	D
671	900	1215	20P21AE1K2RA0NNN	20P41AE1K2RA0NNN	D
746	1000	1350	20P21AE1K3RA0NNN	20P41AE1K3RA0NNN	D
932	1250	1688	20P21AE1K6RA0NNN	20P41AE1K6RA0NNN	D

690V AC, Three-Phase

Drive Output Rating			Non-Regenerative Drives	Regenerative Drives	Frame Size
Normal Duty kW	Normal Duty HP	Amps	Cat. No.	Cat. No.	
447	600	678	20P21AF678RA0NNN	20P41AF678RA0NNN	D
552	700	791	20P21AF791RA0NNN	20P41AF791RA0NNN	D
597	800	904	20P21AF904RA0NNN	20P41AF904RA0NNN	D
671	900	1017	20P21AF1K0RA0NNN	20P41AF1K0RA0NNN	D
746	1000	1130	20P21AF1K1RA0NNN	20P41AF1K1RA0NNN	D
820	1100	1243	20P21AF1K2RA0NNN	20P41AF1K2RA0NNN	D
932	1250	1413	20P21AF1K4RA0NNN	20P41AF1K4RA0NNN	D
1044	1400	1582	20P21AF1K5RA0NNN	20P41AF1K5RA0NNN	D

Factory Installed Options

Each PowerFlex DC drive includes one encoder and DC analog tachometer input. No other factory installed options are available at this time.

User Installed Options

Human Interface and Wireless Interface Modules



No HIM (Blank Plate)
20-HIM-A0

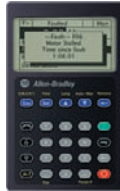

LCD Display, Full
Numeric Keypad
20-HIM-A3



LCD Display,
Programmer Only
20-HIM-A5



Wireless Interface
Module
20-WIM-N1



Remote (Panel Mount)
LCD Display, Full
Numeric Keypad
20-HIM-C3S



Remote (Panel Mount)
LCD Display,
Programmer Only
20-HIM-C5S



Remote (Panel Mount)
Wireless Interface
Module
20-WIM-N4S

Description	Handheld/Local (Drive Mount)	Remote (Panel Mount) IP66, NEMA/UL Type 4x/12 *
	Cat. No.	Cat. No.
No HIM (Blank Plate)	20-HIM-A0	-
LCD Display, Full Numeric Keypad	20-HIM-A3	20-HIM-C3S ‡
LCD Display, Programmer Only	20-HIM-A5	20-HIM-C5S ‡
Wireless Interface Module	20-WIM-N1	20-WIM-N4S

* For indoor use only.

‡ Includes a 1202-C30 interface cable (3 meters) for connection to drive.

Human Interface Module Accessories

Description	Cat. No.
Bezel Kit for LCD HIMs, NEMA/UL Type 1 ‡	20-HIM-B1
PowerFlex HIM Interface Cable, 1 m (39 in) †	20-HIM-H10
Cable Kit (Male-Female) >	
0.33 Meters (1.1 Feet)	1202-H03
1 Meter (3.3 Feet)	1202-H10
3 Meter (9.8 Feet)	1202-H30
9 Meter (29.5 Feet)	1202-H90
DPI/SCANport™ One to Two Port Splitter Cable	1203-S03

‡ Includes a 1202-C30 interface cable (3 meters) for connection to drive.

† Required only when HIM is used as handheld or remote.

> Required in addition to 20-HIM-H10 for distances up to a total maximum of 10 Meters (32.8 Feet).

I/O Option Kit

Description	Cat. No.
I/O Expansion board	20P-S5V62
115V ac to 24V dc 8 Channel I/O Converter Board	20P-S520L

User Installed Options, Continued

Communication Option Kits

Description	Cat. No.
BACnet * MS/TP RS485 Communication Adapter	20-COMM-B
ControlNet™ Communication Adapter (Coax)	20-COMM-C
DeviceNet™ Communication Adapter	20-COMM-D
EtherNet/IP™ Communication Adapter	20-COMM-E
HVAC Communication Adapter ❖	20-COMM-H
Interbus™ Communication Adapter	20-COMM-I
PROFIBUS™ DP Communication Adapter	20-COMM-P
ControlNet™ Communication Adapter (Fiber)	20-COMM-Q
Remote I/O Communication Adapter	20-COMM-R
RS485 DF1 Communication Adapter	20-COMM-S
External Communications Kit Power Supply	20-XCOMM-AC-PS1
DPI External Communications Kit	20-XCOMM-DC-BASE
External DPI I/O Option Board †	20-XCOMM-IO-OPT1
Compact I/O to DPI/SCANport Module	1769-SM1
Serial Null Modem Adapter	1203-SNM
Smart Self-powered Serial Converter (RS232) includes 1203-SFC and 1202-C10 Cables	1203-SSS
Universal Serial Bus™ (USB) Converter includes 2m USB, 20-HIM-H10 & 22-HIM-H10 Cables	1203-USB

† For use only with External DPI Communications Kits 20-XCOMM-DC-BASE.

❖ Only ModBus RTU can be used with Vector Control.

PC Programming Software

Description	
DriveTools™ SP Software †	
DriveExplorer™ Software (Lite/Full) †❖	See publication 9303-PL002... for ordering/pricing information.
Pocket DriveExplorer™ Software	

† Set-up wizards are available for use with DriveTools SP and DriveExplorer (Lite/Full) only.

❖ DriveExplorer Lite is available for free download at: http://www.ab.com/drives/driveexplorer/free_download.html

Isolation Transformers

Isolation Transformers are available for installations that have specific types of AC supply configurations or require drive protection due to AC line disturbances.

Three Phase Primary Voltage			Three Phase Secondary Voltage		
kVA	kW (HP)	Voltage	230V AC Catalog Number	460V AC Catalog Number	575V AC Catalog Number
5	1.2 - 2.2 (1.5 - 3)	230	1321-3TW005-AA	1321-3TW005-AB	N/A
		460	1321-3TW005-BA	1321-3TW005-BB	N/A
		575	1321-3TW005-CA	1321-3TW005-CB	N/A
7.5	3.7 (5)	230	1321-3TW007-AA	1321-3TW007-AB	N/A
		460	1321-3TW007-BA	1321-3TW007-BB	N/A
		575	1321-3TW007-CA	1321-3TW007-CB	N/A
11	5.5 (7.5)	230	1321-3TW011-AA	1321-3TW011-AB	N/A
		460	1321-3TW011-BA	1321-3TW011-BB	N/A
		575	1321-3TW011-CA	1321-3TW011-CB	N/A
14	7.5 (10)	230	1321-3TW014-AA	1321-3TW014-AB	N/A
		460	1321-3TW014-BA	1321-3TW014-BB	N/A
		575	1321-3TW014-CA	1321-3TW014-CB	N/A
20	11 (15)	230	1321-3TW020-AA	1321-3TW020-AB	N/A
		460	1321-3TW020-BA	1321-3TW020-BB	N/A
		575	1321-3TW020-CA	1321-3TW020-CB	N/A
27	15 (20)	230	1321-3TW027-AA	1321-3TW027-AB	N/A
		460	1321-3TW027-BA	1321-3TW027-BB	N/A
		575	1321-3TW027-CA	1321-3TW027-CB	N/A
34	18.5 (25)	230	1321-3TW034-AA	1321-3TW034-AB	N/A
		460	1321-3TW034-BA	1321-3TW034-BB	N/A
		575	1321-3TW034-CA	1321-3TW034-CB	N/A

Three Phase Primary Voltage		Three Phase Secondary Voltage			
kVA	kW (HP)	Voltage	230V AC Catalog Number	460V AC Catalog Number	575V AC Catalog Number
40	22 (30)	230	1321-3TW040-AA	1321-3TW040-AB	N/A
		460	1321-3TW040-BA	1321-3TW040-BB	N/A
		575	1321-3TW040-CA	1321-3TW040-CB	N/A
51	30 (40)	230	1321-3TW051-AA	1321-3TW051-AB	N/A
		460	1321-3TW051-BA	1321-3TW051-BB	N/A
		575	1321-3TW051-CA	1321-3TW051-CB	N/A
63	37 (50)	230	1321-3TH063-AA	1321-3TH063-AB	1321-3TH063-AC
		460	1321-3TH063-BA	1321-3TH063-BB	1321-3TH063-BC
		575	1321-3TH063-CA	1321-3TH063-CB	1321-3TH063-CC
75	45 (60)	230	1321-3TH075-AA	1321-3TH075-AB	1321-3TH075-AC
		460	1321-3TH075-BA	1321-3TH075-BB	1321-3TH075-BC
		575	1321-3TH075-CA	1321-3TH075-CB	1321-3TH075-CC
93	56 (75)	230	1321-3TH093-AA	1321-3TH093-AB	1321-3TH093-AC
		460	1321-3TH093-BA	1321-3TH093-BB	1321-3TH093-BC
		575	1321-3TH093-CA	1321-3TH093-CB	1321-3TH093-CC
118	75 (100)	230	1321-3TH118-AA	1321-3TH118-AB	1321-3TH118-AC
		460	1321-3TH118-BA	1321-3TH118-BB	1321-3TH118-BC
		575	1321-3TH118-CA	1321-3TH118-CB	1321-3TH118-CC
145	93 (125)	230	1321-3TH145-AA	1321-3TH145-AB	1321-3TH145-AC
		460	1321-3TH145-BA	1321-3TH145-BB	1321-3TH145-BC
		575	1321-3TH145-CA	1321-3TH145-CB	1321-3TH145-CC
175	112 (150)	230	1321-3TH175-AA	1321-3TH175-AB	1321-3TH175-AC
		460	1321-3TH175-BA	1321-3TH175-BB	1321-3TH175-BC
		575	1321-3TH175-CA	1321-3TH175-CB	1321-3TH175-CC
220	145 (200)	230	1321-3TH220-AA	1321-3TH220-AB	1321-3TH220-AC
		460	1321-3TH220-BA	1321-3TH220-BB	1321-3TH220-BC
		575	1321-3TH220-CA	1321-3TH220-CB	1321-3TH220-CC
275	187 (250)	230	1321-3TH275-AA	1321-3TH275-AB	1321-3TH275-AC
		460	1321-3TH275-BA	1321-3TH275-BB	1321-3TH275-BC
		575	1321-3TH275-CA	1321-3TH275-CB	1321-3TH275-CC
330	224 (300)	230	1321-3TH330-AA	1321-3TH330-AB	1321-3TH330-AC
		460	1321-3TH330-BA	1321-3TH330-BB	1321-3TH330-BC
		575	1321-3TH330-CA	1321-3TH330-CB	1321-3TH330-CC
440	298 (400)	230	N/A	1321-3TH440-AB	1321-3TH440-AC
		460	N/A	1321-3TH440-BB	1321-3TH440-BC
		575	N/A	1321-3TH440-CB	1321-3TH440-CC
550	373 (500)	230	N/A	1321-3TH550-AB	1321-3TH550-AC
		460	N/A	1321-3TH550-BB	1321-3TH550-BC
		575	N/A	1321-3TH550-CB	1321-3TH550-CC
660	448 (600)	230	N/A	1321-3TH660-AB	1321-3TH660-AC
		460	N/A	1321-3TH660-BB	1321-3TH660-BC
		575	N/A	1321-3TH660-CB	1321-3TH660-CC
770	522 (700)	230	N/A	1321-3TH770-AB	1321-3TH770-AC
		460	N/A	1321-3TH770-BB	1321-3TH770-BC
		575	N/A	1321-3TH770-CB	1321-3TH770-CC
880	597 (800)	230	N/A	1321-3TH880-AB	1321-3TH880-AC
		460	N/A	1321-3TH880-BB	1321-3TH880-BC
		575	N/A	1321-3TH880-CB	1321-3TH880-CC

AC Input Line Reactors and Contactors

If a DC Contactor is used, an AC Input contactor is not needed.

230V AC Input Drives

Non-Regenerative Drive Cat. No.	Regenerative Drive Cat. No.	DC Amps	AC Line Amps	HP	IP00 (Open Style) Line Reactor Cat No.	Line Reactor kW (HP)	AC Input Contactor Cat. No.
20P-21AB7P0	20P-41AB7P0	7	5.7	1.5	1321-3R8-A	.75 (1)	100-C12D10
20P-21AB9P0	20P-41AB9P0	9	7.4	2	1321-3R12-A	1.49 (2)	100-C12D10
20P-21AB012	20P-41AB012	12	9.8	3	1321-3R18-A	0.75-3.7 (1-5)	100-C12D10
20P-21AB020	20P-41AB020	20	16	5	1321-3R18-A	0.75-3.7 (1-5)	100-C23D10
20P-21AB029	20P-41AB029	29	24	7.5	1321-3R55-A	5.5-11 (7.5-15)	100-C30D10
20P-21AB038	20P-41AB038	38	31	10	1321-3R55-A	5.5-11 (7.5-15)	100-C37D10
20P-21AB055	20P-41AB055	55	45	15	1321-3R55-A	5.5-11 (7.5-15)	100-C60D10
20P-21AB073	20P-41AB073	73	60	20	1321-3R80-A	15 (20)	100-C60D10
20P-21AB093	20P-41AB093	93	76	25	1321-3R100-A	18.5-22 (25-30)	100-C85D10
20P-21AB110	20P-41AB110	110	90	30	1321-3R100-A	18.5-22 (25-30)	100-D110D11
20P-21AB146	20P-41AB146	146	119	40	1321-3R160-A	30-37 (40-50)	100-D140D11
20P-21AB180	20P-41AB180	180	147	50	1321-3R160-A	30-37 (40-50)	100-D180D11
20P-21AB218	20P-41AB218	218	178	60	1321-3RB250-A	45-56 (60-75)	100-D180D11
20P-21AB265	20P-41AB265	265	217	75	1321-3RB250-A	45-56 (60-75)	100-D250ED11
20P-21AB360	20P-41AB360	360	294	100	1321-3RB320-A	75 (100)	100-D300ED11
20P-21AB434	20P-41AB434	434	355	125	1321-3RB400-A	93 (125)	100-D420ED11
20P-21AB521	20P-41AB521	521	426	150	1321-3R500-A	112 (150)	100-D630ED11
20P-21AB700	20P-41AB700	700	572	200	1321-3R600-A	149 (200)	100-D630ED11
20P-21AB875	20P-41AB875	875	715	250	1321-3R750-A	186 (250)	100-D860ED11
20P-21AB1K0	20P-41AB1K0	1050	858	300	1321-3R850-A	224 (300)	100-D860ED11

460V AC Input Drives

Non-Regenerative Drive Cat. No.	Regenerative Drive Cat. No.	DC Amps	AC Line Amps	HP	IP00 (Open Style) Line Reactor Cat No.	Line Reactor kW (HP)	AC Input Contactor Cat. No.
20P-21AD4P1	20P-41AD4P1	4.1	3.3	2	1321-3R4-A	.55 (.75)	100-C12D10
20P-21AD6P0	20P-41AD6P0	6	4.9	3	1321-3R8-A	.75 (1)	100-C12D10
20P-21AD010	20P-41AD010	10	8.2	5	1321-3R18-B	1.5-7.5 (2-10)	100-C12D10
20P-21AD014	20P-41AD014	14	11.4	7.5	1321-3R18-B	1.5-7.5 (2-10)	100-C12D10
20P-21AD019	20P-41AD019	19	15.5	10	1321-3R18-B	1.5-7.5 (2-10)	100-C23D10
20P-21AD027	20P-41AD027	27	22.1	15	1321-3R55-B	11-22 (15-30)	100-C23D10
20P-21AD035	20P-41AD035	35	28.6	20	1321-3R55-B	11-22 (15-30)	100-C30D10
20P-21AD045	20P-41AD045	45	36.8	25	1321-3R55-B	11-22 (15-30)	100-C37D10
20P-21AD052	20P-41AD052	52	42.5	30	1321-3R55-B	11-22 (15-30)	100-C43D10
20P-21AD073	20P-41AD073	73	59.6	40	1321-3R80-B	30 (40)	100-C60D10
20P-21AD086	20P-41AD086	86	70.3	50	1321-3R100-B	37-45 (50-60)	100-C85D10
20P-21AD100	20P-41AD100	100	81.7	60	1321-3R100-B	37-45 (50-60)	100-C85D10
20P-21AD129	20P-41AD129	129	105.4	75	1321-3R160-B	56-75 (75-100)	100-D110D11
20P-21AD167	20P-41AD167	167	136.4	100	1321-3R160-B	56-75 (75-100)	100-D140D11
20P-21AD207	20P-41AD207	207	169.1	125	1321-3RB250-B	93-112 (125-150)	100-D180D11
20P-21AD250	20P-41AD250	250	204.3	150	1321-3RB250-B	93-112 (125-150)	100-D210ED11
20P-21AD330	20P-41AD330	330	269.6	200	1321-3RB320-B	149 (200)	100-D300ED11
20P-21AD412	20P-41AD412	412	336.6	250	1321-3RB400-B	186.4 (250)	100-D420ED11
20P-21AD495	20P-41AD495	495	404.4	300	1321-3R500-B	223.7 (300)	100-D420ED11
20P-21AD667	20P-41AD667	667	544.9	400	1321-3R600-B	298.3 (400)	100-D630ED11
20P-21AD830	20P-41AD830	830	678.1	500	1321-3R750-B	372.8 (500)	100-D860ED11
20P-21AD996	20P-41AD996	996	813.7	600	1321-3R850-B	447.4 (600)	100-D860ED11
20P-21AD1K1	20P-41AD1K1	1162	949.4	700	1321-3R1000-B	552 (700)	100-G860KD22
20P-21AD1K3	20P-41AD1K3	1328	1085.0	800	(1)	-	100-G860KD22
20P-21AD1K4	20P-41AD1K4	1494	1220.6	900	(2)	-	100-G1200KD12

(1) No Line Reactor available for this drive rating. Use the recommended Isolation Transformer: 1321-3TH880-BB.

(2) No Line Reactor or Isolation Transformer available for this drive rating - must be sourced locally.

575V AC Input Drives

Non-Regenerative Drive Cat. No.	Regenerative Drive Cat. No.	DC Amps	AC Line Amps	HP	IP00 (Open Style) Line Reactor Cat No.	Line Reactor kW (HP)	AC Input Contactor Cat. No.
20P21AE810	20P41AE810	810	661.8	600	1321-3R600-B	447 (600)	100-D860ED11
20P21AE1K0	20P41AE1K0	1080	882.4	800	1321-3R750-B	597 (800)	100-G700KD22
20P21AE1K2	20P41AE1K2	1215	992.7	900	1321-3R850-B	671 (900)	100-G860KD22
20P21AE1K3	20P41AE1K3	1350	1103.0	1000	1321-3R1000-B	746 (1000)	100-G1000KD12
20P21AE1K6	20P41AE1K6	1687.5	1378.7	1250	(1)	–	(2)

(1) No Line Reactor or Isolation Transformer available for this drive rating - must be sourced locally.

(2) No AC Input Contactor available for this drive rating - must be sourced locally.

690V AC Input Drives

Non-Regenerative Drive Cat. No.	Regenerative Drive Cat. No.	DC Amps	AC Line Amps	HP	IP00 (Open Style) Line Reactor Cat No.	Line Reactor kW (HP)	AC Input Contactor Cat. No.
20P21AF678	20P41AF678	678	554	600	Line Reactors or Isolation Transformers for 690V AC input voltage drives must be sourced locally.	–	100-D630ED11
20P21AF791	20P41AF791	791	646	700		–	100-D860ED11
20P21AF904	20P41AF904	904	739	800		–	100-D860ED11
20P21AF1K0	20P41AF1K0	1017	831	900		–	100-D860ED11
20P21AF1K1	20P41AF1K1	1130	923	1000		–	100-G700KD22
20P21AF1K2	20P41AF1K2	1243	1016	1100		–	100-G860KD22
20P21AF1K4	20P41AF1K4	1412.5	1154	1250		–	100-G1200KD12
20P21AF1K5	20P41AF1K5	1582	1292	1400		–	100-G1200KD12

Dynamic Brake Resistor Kits and DC Output Contactors

See [Alternate Dynamic Brake Resistor Kits and DC Output Contactors on page 15](#) for recommended alternate DC Output Contactors for 575V and 690V AC input drives, respectively.

230V AC Input Drives

Frame	Drive Current Rating Code	DC Amps	AC Line Amps	HP	Dynamic Brake Resistor Kit Cat. No.	Armature Voltage (Volts)	DB Resistor Size (ohms)	DB Resistor Size (Watts)	Brake Amps Required	DC Loop Contactor Cat. No. ⁽³⁾	DC Contactor Crimp Lugs Cat. No. ⁽⁴⁾
A	7P0	7	5.7	1.5	1370-DBL62	240	20	420	12.00	1370-DC56	1370-LG40
	9P0	9	7.4	2	1370-DBL63	240	20	420	12.00	1370-DC56	1370-LG40
	012	12	9.8	3	1370-DBL64	240	15	420	16.00	1370-DC56	1370-LG40
	020	20	16	5	1370-DBL65	240	8.6	420	27.91	1370-DC56	1370-LG40
	029	29	24	7.5	1370-DBL66	240	6	345	40.00	1370-DC56	1370-LG40
	038	38	31	10	1370-DBL67	240	5	330	48.00	1370-DC56	1370-LG40
	055	55	45	15	1370-DBL68	240	3.5	385	68.57	1370-DC56	1370-LG56
	073	73	60	20	1370-DBL69	240	2.6	385	92.31	1370-DC110	1370-LG92
	093	93	76	25	1370-DBL70	240	2	330	120.00	1370-DC110	1370-LG92
	110	110	90	30	1370-DBL71	240	2	330	120.00	1370-DC110	1370-LG110
B	146	146	119	40	1370-DBL72	240	0.7	280	342.86	1370-DC180	1370-LG160
	180	180	147	50	1370-DBL73	240	0.5	365	480.00	1370-DC180	1370-LG180
	218	218	178	60	1370-DBL74	240	0.5	365	480.00	1370-DC280	1370-LG228
	265	265	217	75	1370-DBL75	240	2	330	120.00	1370-DC280	1370-LG268
	360	360	294	100	1370-DBL76	240	1.4	290	171.43	(1)	(5)
	434	434	355	125	(1)	240	0.5	1458	651	(1)	(5)
	521	521	426	150	(1)	240	0.322	6221	781	(1)	(5)
C	700	700	572	200	(2)	240	–	–	–	(1)	(5)
	875	875	715	250	(2)	240	–	–	–	(1)	(5)
D	1K0	1050	858	300	(2)	240	–	–	–	(1)	(5)

(1) See [Alternate Dynamic Brake Resistor Kits and DC Output Contactors Amp](#) on page 15.

(2) No Dynamic Brake Resistor kit available for this drive rating - must be sourced locally.

(3) Coil voltage = 115V AC, 50/60Hz.

(4) See [DC Contactor Crimp Lug Kit Specifications Amp](#) on page 14 for more information.

(5) Wire and Lug size dependant on enclosure dimensions and local codes.

460V AC Input Drives

Frame	Drive Current Rating Code	DC Amps	AC Line Amps	HP	Dynamic Brake Resistor Kit Cat. No.	Armature Voltage (Volts)	DB Resistor Size (ohms)	DB Resistor Size (Watts)	Brake Amps Required	DC Loop Contactor Cat. No.(3)	DC Contactor Crimp Lugs Cat. No.(4)
A	4P1	4.1	3.3	2	1370-DBH63	500	81	255	6.17	1370-DC56	1370-LG40
	6P0	6	4.9	3	1370-DBH64	500	62	245	8.06	1370-DC56	1370-LG40
	010	10	8.2	5	1370-DBH65	500	45	245	11.11	1370-DC56	1370-LG40
	014	14	11.4	7.5	1370-DBH66	500	27	350	18.52	1370-DC56	1370-LG40
	019	19	15.5	10	1370-DBH67	500	20	420	25.00	1370-DC56	1370-LG40
	027	27	22.1	15	1370-DBH68	500	12	405	41.67	1370-DC56	1370-LG40
	035	35	28.6	20	1370-DBH69	500	5	330	100.00	1370-DC56	1370-LG40
	045	45	36.8	25	1370-DBH70	500	4.5	330	111.11	1370-DC56	1370-LG52
	052	52	42.5	30	1370-DBH71	500	3.5	385	142.86	1370-DC56	1370-LG52
	073	73	59.6	40	1370-DBH72	500	2.6	345	192.31	1370-DC110	1370-LG92
	086	86	70.3	50	1370-DBH73	500	2	345	250.00	1370-DC110	1370-LG92
	100	100	81.7	60	1370-DBH74	500	2	345	250.00	1370-DC110	1370-LG110
129	129	105.4	75	1370-DBH75	500	1	270	500.00	1370-DC180	1370-LG140	
B	167	167	136.4	100	1370-DBH76	500	0.7	280	714.29	1370-DC180	1370-LG180
	207	207	169.1	125	1370-DBH77	500	0.7	280	714.29	1370-DC280	1370-LG228
	250	250	204.3	150	1370-DBH78	500	0.5	365	1000.00	1370-DC280	1370-LG268
	330	330	269.6	200	1370-DBH79	500	0.7	280	714.29	(1)	(5)
	412	412	336.6	250	(1)	500	0.808	7292	-	(1)	(5)
C	495	495	404.4	300	(1)	500	0.595	6069	-	(1)	(5)
	667	667	544.9	400	(1)	500	0.542	6439	-	(1)	(5)
D	800	830	678.1	500	(2)	500	0.463	6338	-	(1)	(5)
	960	996	813.7	600	(2)	500	0.322	6221	-	(1)	(5)
	1K1	1162	949.4	700	(2)	500	0.322	6221	-	(1)	(5)
	1K3	1328	1085.0	800	(2)	500	0.255	5718	-	(1)	(5)
	1K4	1494	1220.6	900	(2)	500	0.255	5718	-	(1)	(5)

- (1) See [Alternate Dynamic Brake Resistor Kits and DC Output Contactors Amp](#) on page 15.
(2) No Dynamic Brake Resistor kit available for this drive rating - must be sourced locally.
(3) Coil voltage = 115V AC, 50/60Hz.
(4) See [DC Contactor Crimp Lug Kit Specifications Amp](#) on page 14 for more information.
(5) Wire and Lug size dependant on enclosure dimensions and local codes.

DC Contactor Crimp Lug Kit Specifications

Use the information provided in the table below to assist you in ordering the correct Lug kit for your application.

Rated Motor Armature Current (1) A DC	DC Contactor Rating A DC	Armature Conductor Size (2) AWG	DB Conductor Size (3) AWG	Armature Conductor Crimp Lug Hole Size	DB Conductor Crimp Lug Hole Size	Lug Kit Catalog Number
4.1...35	56	8	8	#10	#10	1370-LG40
45...52	56	6	8	#10	#10	1370-LG52
55	56	4	8	#10	#10	1370-LG56
60...86	110	2	6	0.25 in.	0.25 in.	1370-LG92
100...110	110	1/0	4	0.25 in.	0.25 in.	1370-LG110
129	180	2/0	2	0.3125 in.	0.3125 in.	1370-LG140
146	180	3/0	2	0.3125 in.	0.3125 in.	1370-LG160
147...167	180	4/0	2	0.3125 in.	0.3125 in.	1370-LG180
207...218	280	300MCM	1/0	0.5 in.	0.375 in.	1370-LG228
250...265	280	400MCM	2/0	0.5 in.	0.375 in.	1370-LG268
266...280	280	500MCM	3/0	0.5 in.	0.375 in.	1370-LG280

- (1) The Rated Motor Armature Current is taken directly from the motor nameplate or motor data. The current listed in this column is the maximum current allowed for the Armature Conductor Size (column 3) and the DC Contactor Rating (column 2).
(2) The armature conductors are sized by multiplying the Rated Motor Armature Current by 1.25 as provided for in NEC 420-22 (1987). The DC lug ratings are determined from NEC Table 310-16 (1987) for copper conductors, insulation temperature rated at 75° C (167° F) at an ambient temperature of 30° C (86° F). If conditions are other than shown in NEC Table 310-16, then refer to application codes.
(3) The dynamic braking (DB) conductors are sized as in footnote 2 above, but at half ampacity due to the short time duration of current flow in these conductors, and has been sized to satisfy NEMA Standard ICS 3-302.62 - Dynamic Braking. If the load inertia is larger than that of the motor, calculations must be made to determine correct conductor sizing and DB resistor wattage per NEMA Standard ICS 3-302.62.

Alternate Dynamic Brake Resistor Kits and DC Output Contactors

The following alternate dynamic brake resistor kits and/or DC output contactors may be used with the corresponding PowerFlex DC drives but must be sourced separately from the drive.

230V AC Input Drives

Frame	Drive Current Rating Code	DC Amps	AC Line Amps	HP	Dynamic Brake Resistor Kit Cat. No.	Armature Voltage (Volts)	DB Resistor Size (ohms)	DB Resistor Size (Watts)	Brake Amps Required	DC Loop Contactor Cat. No. ⁽²⁾		DC Contactor Crimp Lugs Cat. No. ⁽³⁾
										Drive w/No Dynamic Brake	Drive w Dynamic Brake	
B	360	360	294	100	1370-DBL76	240	1.4	290	171.43	ABB_EHDB360C2P-1L2S	ABB_EHDB360C-1L22SS	(4)
	434	434	355	125	CUTLER-HAMMER_G3AP50 (Qty 4 - two in series, two in parallel)	240	0.5	1458	651	ABB_EHDB520C2P-1L2S	ABB_EHDB520C-1L22SS	
C	521	521	426	150	HUBBELL_Y139W322GB	240	0.322	6221	781			
	700	700	572	200	(1)	240	-	-	-	ABB_EHDB800C2P-1L2S	ABB_EHDB800C-1L22SS	
D	875	875	715	250		240	-	-	-	ABB_EHDB960C2P-1L2S	ABB_EHDB960C-1L22SS	
	1K0	1050	858	300		240	-	-	-	SIEMENS-MFG_14-193-101-58-2 (Qty 2)	SIEMENS-MFG_14-193-101-58-2 (Qty 1)	

(1) No Dynamic Brake Resistor kit available for this drive rating - must be sourced locally.

(2) Coil voltage = 115V AC, 50/60Hz.

(3) See [DC Contactor Crimp Lug Kit Specifications Amp](#) on page 14 for more information.

(4) Wire and Lug size dependant on enclosure dimensions and local codes.

460V AC Input Drives

Frame	Drive Current Rating Code	DC Amps	AC Line Amps	HP	Dynamic Brake Resistor Kit Cat. No.	Armature Voltage (Volts)	DB Resistor Size (ohms)	DB Resistor Size (Watts)	Brake Amps Required	DC Loop Contactor Cat. No. ⁽²⁾		DC Contactor Crimp Lugs Cat. No. ⁽³⁾
										Drive w/No Dynamic Brake	Drive w Dynamic Brake	
B	330	330	269.6	200	1370-DBH79	500	0.7	280	714.29	ABB_EHDB360C2P-1L2S	ABB_EHDB360C-1L22SS	(4)
	412	412	336.6	250	HUBBELL_Y95W808GB	500	0.808	7292	-	ABB_EHDB520C2P-1L2S	ABB_EHDB520C-1L22SS	
C	495	495	404.4	300	HUBBELL_Y101W595GB	500	0.595	6069	-	ABB_EHDB520C2P-1L2S	ABB_EHDB520C-1L22SS	
	667	667	544.9	400	HUBBELL_Y109W542GB	500	0.542	6439	-	ABB_EHDB800C2P-1L2S	ABB_EHDB800C-1L22SS	
D	800	830	678.1	500	(1)	500	0.463	6338	-	ABB_EHDB960C2P-1L2S	ABB_EHDB960C-1L22SS	
	960	996	813.7	600		500	0.322	6221	-	SIEMENS-MFG_14-193-101-58-2 (Qty 2)	SIEMENS-MFG_14-193-101-58-2 (Qty 1)	
	1K1	1162	949.4	700		500	0.322	6221	-	SIEMENS-MFG_14-193-101-58-2 (Qty 2)	SIEMENS-MFG_14-193-101-58-2 (Qty 1)	
	1K3	1328	1085.0	800		500	0.255	5718	-	CUTLER-HAMMER_6702ED636-2 (Qty 2)	CUTLER-HAMMER_6702ED636-2 (Qty 1)	
	1K4	1494	1220.6	900		500	0.255	5718	-	CUTLER-HAMMER_6702ED636-2 (Qty 2)	CUTLER-HAMMER_6702ED636-2 (Qty 1)	

(1) No Dynamic Brake Resistor kit available for this drive rating - must be sourced locally.

(2) Coil voltage = 115V AC, 50/60Hz.

(3) See [DC Contactor Crimp Lug Kit Specifications Amp](#) on page 14 for more information.

(4) Wire and Lug size dependant on enclosure dimensions and local codes.

575V AC Input Drives

Frame	Drive Current Rating Code	DC Amps	AC Line Amps	HP	Dynamic Brake Resistor Kit Cat. No.	Armature Voltage (Volts)	DB Resistor Size (ohms)	DB Resistor Size (Watts)	Brake Amps Required	DC Loop Contactor Cat. No. ⁽²⁾		DC Contactor Crimp Lugs Cat. No. ⁽³⁾
										Drive w/No Dynamic Brake	Drive w Dynamic Brake	
D	810	810	662	600	(1)	600	0.494	-	-	ABB_EHDB960C2P-1L2S	ABB_EHDB960C-1L22SS	(4)
	1K0	1080	882	800		600	0.370	-	-	SIEMENS-MFG_14-193-101-58-2 (Qty 2)	SIEMENS-MFG_14-193-101-58-2 (Qty 1)	
	1K2	1215	993	900		600	0.329	-	-	SIEMENS-MFG_14-193-101-58-2 (Qty 2)	SIEMENS-MFG_14-193-101-58-2 (Qty 1)	
	1K3	1350	1103	1000		600	0.296	-	-	CUTLER-HAMMER_6702ED636-2 (Qty 2)	CUTLER-HAMMER_6702ED636-2 (Qty 1)	
	1K6	1688	1379	1250		600	0.237	-	-	CUTLER-HAMMER_6702ED636-2 (Qty 2)	CUTLER-HAMMER_6702ED636-2 (Qty 1)	

(1) No Dynamic Brake Resistor kit available for this drive rating - must be sourced locally.

(2) Coil voltage = 115V AC, 50/60Hz.

(3) See [DC Contactor Crimp Lug Kit Specifications Amp](#) on page 14 for more information.

(4) Wire and Lug size dependant on enclosure dimensions and local codes.

690V AC Input Drives

Frame	Drive Current Rating Code	DC Amps	AC Line Amps	HP	Dynamic Brake Resistor Kit Cat. No.	Armature Voltage (Volts)	DB Resistor Size (ohms)	DB Resistor Size (Watts)	Brake Amps Required	DC Loop Contactor Cat. No. ⁽²⁾		DC Contactor Crimp Lugs Cat. No. ⁽³⁾
										Drive w/No Dynamic Brake	Drive w Dynamic Brake	
D	678	678	554	600	⁽¹⁾	700	0.688	–	–	SIEMENS-MFG_14-193-101-58-2 (Qty 2)	SIEMENS-MFG_14-193-101-58-2 (Qty 1)	⁽⁴⁾
	791	791	646	700		700	0.590	–	–	SIEMENS-MFG_14-193-101-58-2 (Qty 2)	SIEMENS-MFG_14-193-101-58-2 (Qty 1)	
	904	904	739	800		700	0.516	–	–	SIEMENS-MFG_14-193-101-58-2 (Qty 2)	SIEMENS-MFG_14-193-101-58-2 (Qty 1)	
	1K0	1017	831	900		700	0.459	–	–	SIEMENS-MFG_14-193-101-58-2 (Qty 2)	SIEMENS-MFG_14-193-101-58-2 (Qty 1)	
	1K1	1130	923	1000		700	0.413	–	–	SIEMENS-MFG_14-193-101-58-2 (Qty 2)	SIEMENS-MFG_14-193-101-58-2 (Qty 1)	
	1K2	1243	1016	1100		700	0.375	–	–	SIEMENS-MFG_14-193-101-58-2 (Qty 2)	SIEMENS-MFG_14-193-101-58-2 (Qty 1)	
	1K4	1413	1154	1250		700	0.330	–	–	CUTLER-HAMMER_6702ED636-2 (Qty 2)	CUTLER-HAMMER_6702ED636-2 (Qty 1)	
	1K5	1582	1292	1400		700	0.295	–	–	CUTLER-HAMMER_6702ED636-2 (Qty 2)	CUTLER-HAMMER_6702ED636-2 (Qty 1)	

- ⁽¹⁾ No Dynamic Brake Resistor kit available for this drive rating - must be sourced locally.
- ⁽²⁾ Coil voltage = 115V AC, 50/60Hz.
- ⁽³⁾ See [DC Contactor Crimp Lug Kit Specifications Amp](#) on page 14 for more information.
- ⁽⁴⁾ Wire and Lug size dependant on enclosure dimensions and local codes.

Frame D Terminal Adapter Kits

The following frame D drives require the listed terminal adapter kits in order to meet UL installation requirements.

Voltage Class	Drive Current Rating Code	U, V, W Terminal Adapter Kit Number	C, D Terminal Adapter Kit Number
230	1K0	SK-20P-S726171	–
460	1K1		–
	1K3		–
	1K4		–
575	1K0		–
	1K2		–
	1K3		–
	1K6		SK-20P-S726173
690	1K0		–
	1K1		–
	1K2		–
	1K4		–
	1K5	–	

Installation Considerations

The PowerFlex Digital DC drive has the following built in protective features to help simplify installation:

- Ground fault protection during start up and running ensures reliable operation
- Electronic motor overload protection increases motor life

There are many other factors that must be considered for optimal performance in any given application. The block diagram below highlights the primary installation considerations.

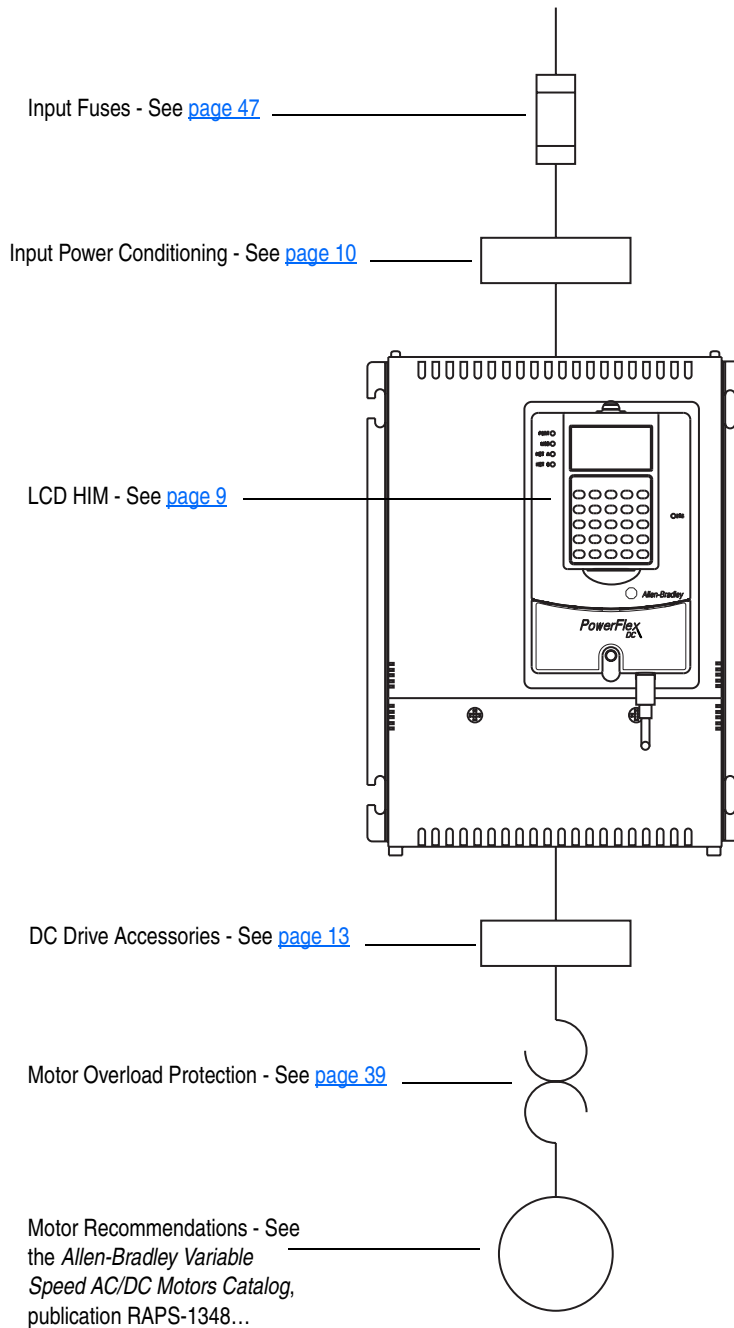

Power Wiring

AC Input Voltages

PowerFlex DC drives are rated for the following AC input voltages @ 50/60 Hz $\pm 5\%$:

Mains Circuit (Terminals U, V, W)

- 230V $\pm 10\%$, 3Ph
- 400V $\pm 10\%$, 3Ph
- 440V $\pm 10\%$, 3Ph
- 460V $\pm 10\%$, 3Ph
- 480V $\pm 10\%$, 3Ph
- 575V $\pm 10\%$, 3Ph
- 690V $\pm 10\%$, 3Ph

Field Circuit (Terminals U1, V1)

- 230V $\pm 10\%$, 1Ph
- 400V $\pm 10\%$, 1Ph
- 460V $\pm 10\%$, 1Ph

Control Circuit (Terminals U2, V2)

- 115V $\pm 15\%$ or 230V $\pm 15\%$, 1Ph

Note: For frame B and C drives only, a jumper must be placed between terminals SA-SB on the Switching Power Supply circuit board for the control circuits to work with 115V AC input. Refer to [SA-SB Terminal Block Location on Frame B Drives on page 34](#) and [SA-SB Terminal Block Location on Frame C Drives on page 35](#) for terminal block locations.

DC Output Voltages

The output voltages below take into account an AC input undervoltage within the stated tolerance limits and a voltage drop of 4% due to an AC input line reactor. It is the same as the rated armature voltage suggested for the connected motor.

Armature Circuit

AC Input Voltage (Terminals U, V, W)	DC Output Armature Voltage (Terminals C & D)	
	Two Quadrant Drive	Four Quadrant Drive
230V $\pm 10\%$, 3Ph	260V	240V
400V $\pm 10\%$, 3Ph	470V	420V
440V $\pm 10\%$, 3Ph	530V	460V
460V $\pm 10\%$, 3Ph	560V	480V
480V $\pm 10\%$, 3Ph	580V	500V
575V $\pm 10\%$, 3Ph	680V	600V
690V $\pm 10\%$, 3Ph	810V	720V

Field Circuit

AC Input Voltage (Terminals U1 & V1)	DC Output Field Voltage ⁽¹⁾ (Terminals C1 & D1)	
	Fixed Field	Adjustable Field
230V $\pm 10\%$, 1Ph	200V	200V
400V $\pm 10\%$, 1Ph	310V	310V
460V $\pm 10\%$, 1Ph	360V	360V

⁽¹⁾ The max field voltage is equal to 0.85 x AC input line voltage

Typical Power Wiring Diagrams

The following diagram represents recommended power wiring configurations:

Power Wiring with AC Input Contactor

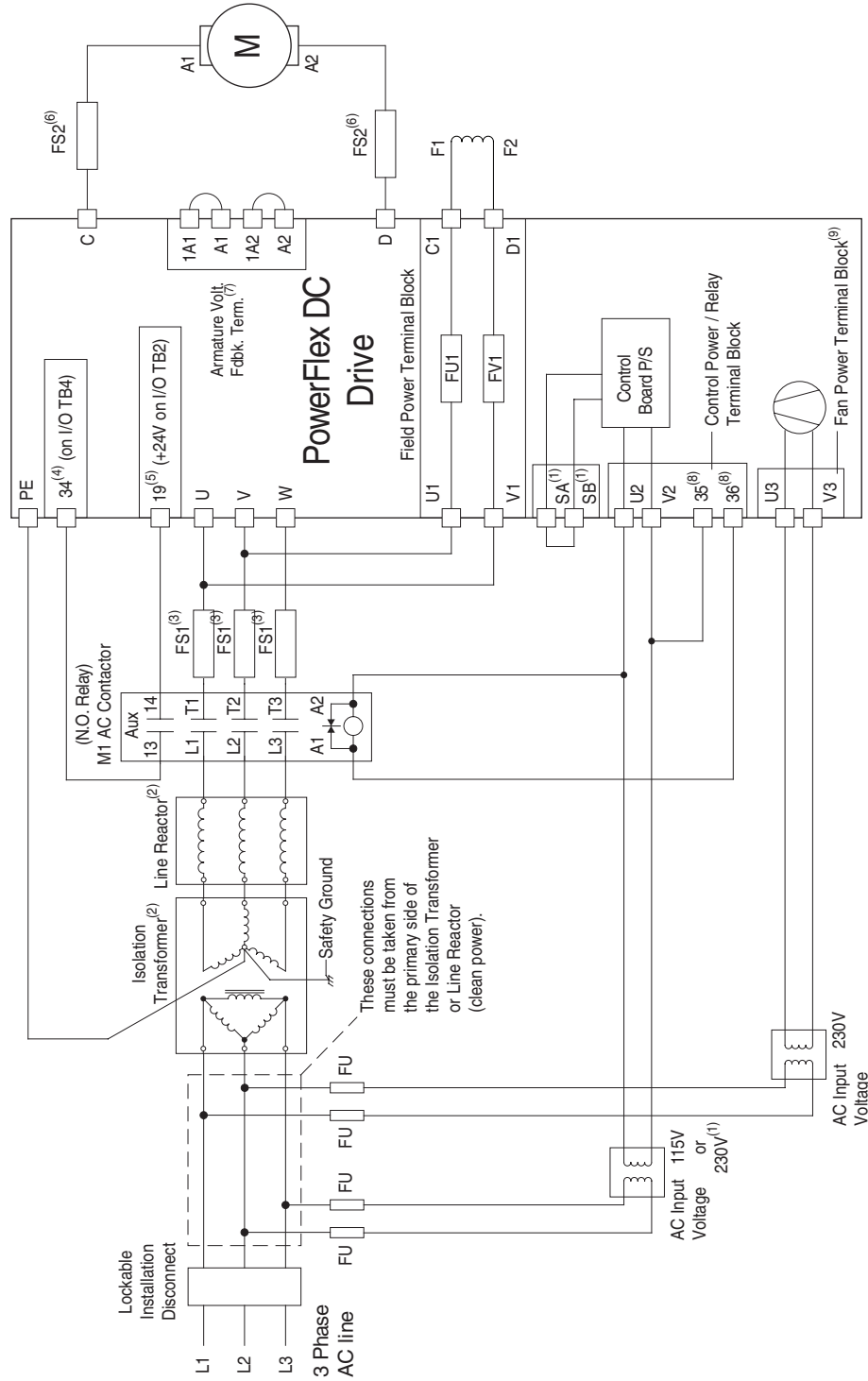

- (1) For frame B and C drives only, a jumper is required between terminals SA and SB for 115V AC control input power. See [Control Circuit Input Power on page 32](#) for more information.
- (2) An Isolation Transformer and/or 3...5% impedance Line Reactor is required. If the Isolation Transformer provides the required 3...5% impedance, a Line Reactor is not required. See [AC Input Line Reactors and Contactors on page 12](#) and [Isolation Transformers on page 10](#) for recommendations.
- (3) AC input fuses for the armature converter are customer supplied for frame A and B drives and are internally mounted on frame C and D drives. See [Circuit Protection on page 47](#) for fuse recommendations.
- (4) Par 140 [Digital In8 Sel] set to 31 "Contactor"
- (5) If using the +24V internal power supply, terminal 18 (24V common) must be jumpered to terminal 35 (digital input common).
- (6) Customer supplied armature output fuses are required on four quadrants and are recommended on two quadrant Frame A and B drives. See [Circuit Protection on page 47](#) for fuse recommendations. Fuses with Trip Indicator Switches are recommended for Inverting Fault protection when the motor will be Field Weakened and run above base speed. Refer to [Power Wiring with Armature Output Fuses and Inverting Fault Status on page 22](#).
- (7) Optional armature voltage feedback sensing not needed with AC Contactor if Fuses with Trip Indicator are used (and wired to Inverting Fault input). See [Power Wiring with Armature Output Fuses and Inverting Fault Status on page 22](#). If regular fuses are used, armature voltage TB can be used for overvoltage fault.
- (8) Par 1391 [ContactorControl] = 1 "AC Ctrlr" and Par 1392 [Relay Out 1 Sel] = 25 "Contactor". **Important:** Terminal 35 and 36 are on the Control Power / Relay Terminal block, NOT the I/O terminal blocks. See [Relay Outputs on page 39](#) for locations.
- (9) Frame C & D drives only require an external power supply for the heatsink cooling fan. See [Frame C Heatsink Cooling Fans Power Supply Terminals on page 36](#) and [Frame D Heatsink Cooling Fan Power Supply Terminals on page 37](#) for more information.

Power Wiring with DC Output Contactor

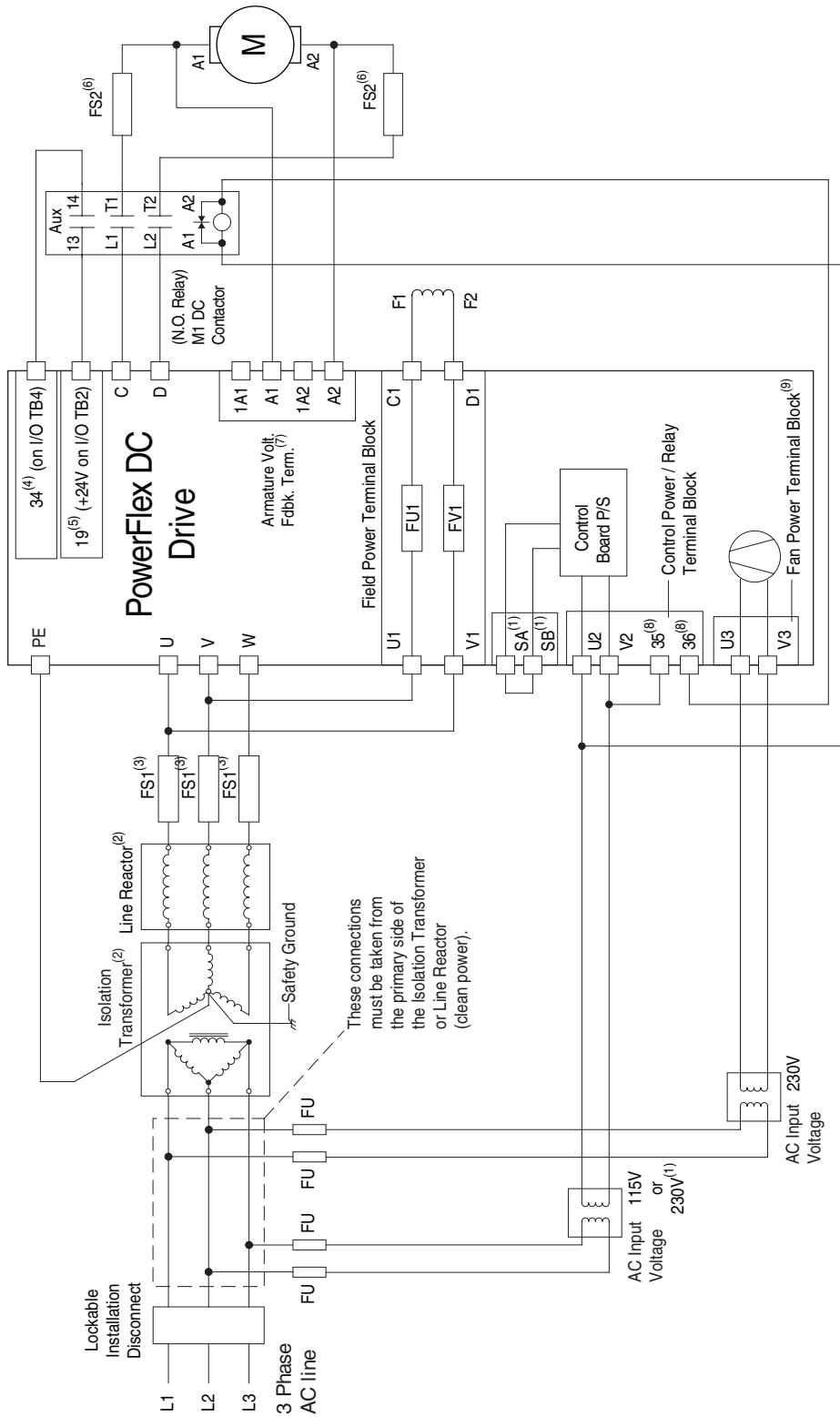

- (1) For frame B and C drives only, a jumper is required between terminals SA and SB for 115V AC control input power. See [Control Circuit Input Power on page 32](#) for more information.
- (2) An Isolation Transformer and/or 3...5% impedance Line Reactor is required. If the Isolation Transformer provides the required 3...5% impedance, a Line Reactor is not required. See [AC Input Line Reactors and Contactors on page 12](#) and [Isolation Transformers on page 10](#) for recommendations.
- (3) AC input fuses for the armature converter are customer supplied for frame A and B drives and are internally mounted on frame C and D drives. See [Circuit Protection on page 47](#) for fuse recommendations.
- (4) Par 140 [Digital In8 Sel] set to 31 "Contactor"
- (5) If using the +24V internal power supply, terminal 18 (24V common) must be jumpered to terminal 35 (digital input common).
- (6) Customer supplied armature output fuses are required on four quadrant and are recommended on two quadrant Frame A and B drives. See [Circuit Protection on page 47](#) for fuse recommendations. Fuses with Trip Indicator Switches are recommended for Inverting Fault protection when the motor will be Field Weakened and run above base speed. Refer to [Power Wiring with Armature Output Fuses and Inverting Fault Status on page 22](#).
- (7) Optional armature voltage feedback sensing not needed with DC contactor if Fuses with Trip Indicator are used (and wired to Inverting Fault input). See [Power Wiring with Armature Output Fuses and Inverting Fault Status on page 22](#). If regular fuses are used, armature voltage TB can be used for overvoltage fault.
- (8) Par 1391 [ContactorControl] = 3 "DC Cntctr" and Par 1392 [Relay Out 1 Sel] = 25 "Contactor". **Important:** Terminal 35 and 36 are on the Control Power / Relay Terminal block, NOT the I/O terminal blocks. See [Relay Outputs on page 39](#) for locations.
- (9) Frame C & D drives only require an external power supply for the heatsink cooling fan. See [Frame C Heatsink Cooling Fans Power Supply Terminals on page 36](#) and [Frame D Heatsink Cooling Fan Power Supply Terminals on page 37](#) for more information.

Power Wiring with DC Output/Dynamic Braking Contactor and a Dynamic Brake

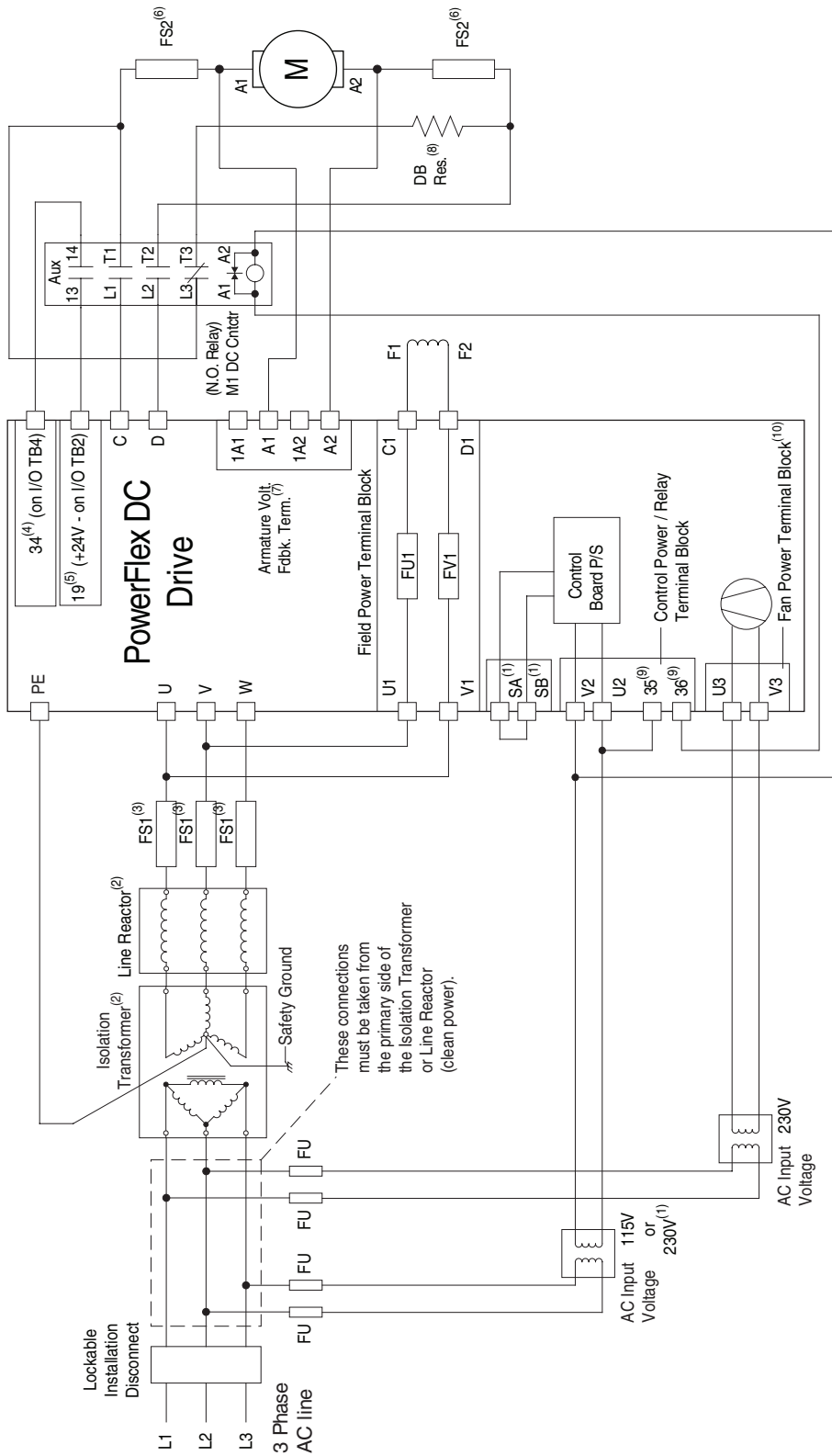

- (1) For frame B and C drives only, a jumper is required between terminals SA and SB for 115V AC control input power. See [Control Circuit Input Power on page 32](#) for more information.
- (2) An isolation transformer and/or 3...5% impedance Line Reactor is required. If the isolation transformer provides the required 3...5% impedance, a Line Reactor is not required. See [AC Input Line Reactors and Contactors on page 12](#) and [Isolation Transformers on page 10](#) for recommendations.
- (3) AC input fuses for the armature converter are customer supplied for frame A and B drives and are internally mounted on frame C and D drives. See [Circuit Protection on page 47](#) for fuse recommendations.
- (4) Par 140 [Digital In8 Sel] set to 31 "Contactor"
- (5) If using the +24V internal power supply, terminal 18 (24V common) must be jumpered to terminal 35 (digital input common).
- (6) Customer supplied armature output fuses are required on four quadrant and are recommended on two quadrant Frame A and B drives. See [Circuit Protection on page 47](#) for fuse recommendations. Fuses with Trip Indicator Switches are recommended for Inverting Fault protection when the motor will be Field Weakened and run above base speed. Refer to [Power Wiring with Armature Output Fuses and Inverting Fault Status on page 22](#).
- (7) Optional armature voltage feedback sensing not needed with DC contactor if Fuses with Trip Indicator are used (and wired to Inverting Fault input). See [Power Wiring with Armature Output Fuses and Inverting Fault Status on page 22](#). If regular fuses are used, armature voltage TB can be used for overvoltage fault.
- (8) The "Enable" input must be removed in order to perform a dynamic braking stop.
- (9) Par 1391 [ContactorControl] = 3 "DC Cntcr" and Par 1392 [Relay Out 1 Sel] = 24 "ContactorDB". **Important:** Terminal 35 and 36 are on the Control Power / Relay Terminal block, NOT the I/O terminal blocks. See [Relay Outputs on page 39](#) for locations.
- (10) Frame C & D drives only require an external power supply for the heatsink cooling fan. See [Frame C Heatsink Cooling Fans Power Supply Terminals on page 36](#) and [Frame D Heatsink Cooling Fan Power Supply Terminals on page 37](#) for more information.

Power Wiring with Armature Output Fuses and Inverting Fault Status

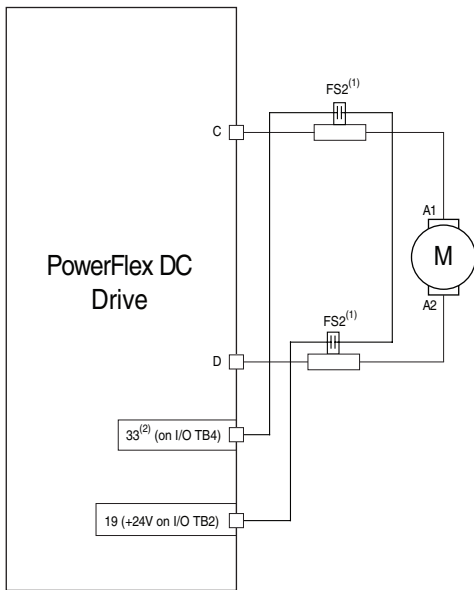

- (1) Customer supplied armature output fuses are required on four quadrant and are recommended on two quadrant Frame A and B drives. See [Circuit Protection on page 47](#) for fuse recommendations. Fuses with Trip Indicator Switches are recommended for Inverting Fault protection when the motor will be Field Weakened and run above base speed.
- (2) Par 139 [Digital In7 Sel] set to 64 "Invert Flt".

Armature Power Terminal Connections

Terminals	Description
U, V, W	Three phase AC input to the armature converter
C, D	DC output to the motor armature
PE	Safety ground

Frame A Armature Terminal Block Locations

Bottom View



Loosen the two screws that secure the power terminal cover to the drive chassis and remove the terminal cover in order to connect the armature power wiring.

Front View

Note: Front view of drive shown with bottom protective and power terminal covers removed.

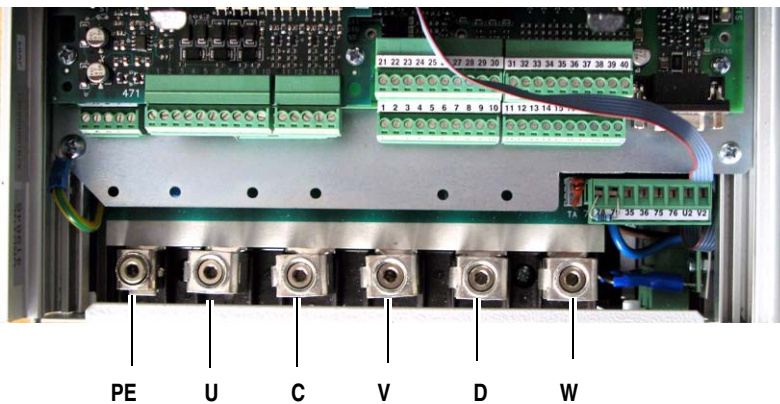

ATTENTION: Do not operate the drive with the power terminal cover removed. Operating the drive with the power terminal cover removed may result in a hazardous condition that could cause personal injury and/or equipment damage.

Frame B Armature Terminal Block Locations

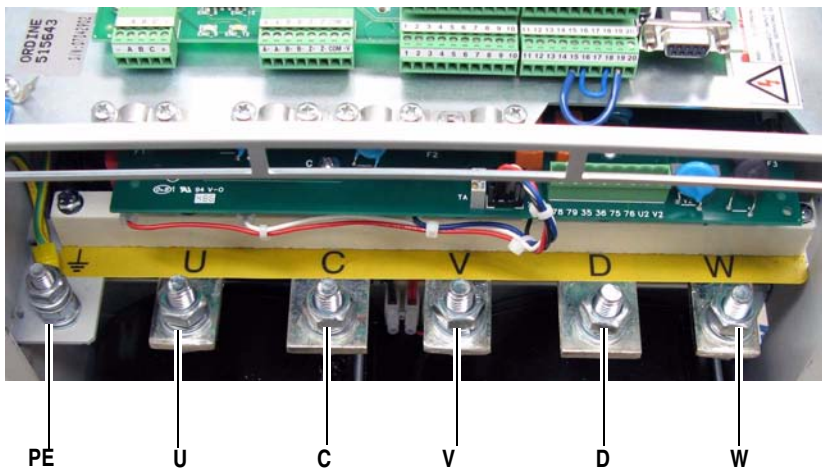

Frame C Armature Terminal Block Locations

Front View



PE U C V D W

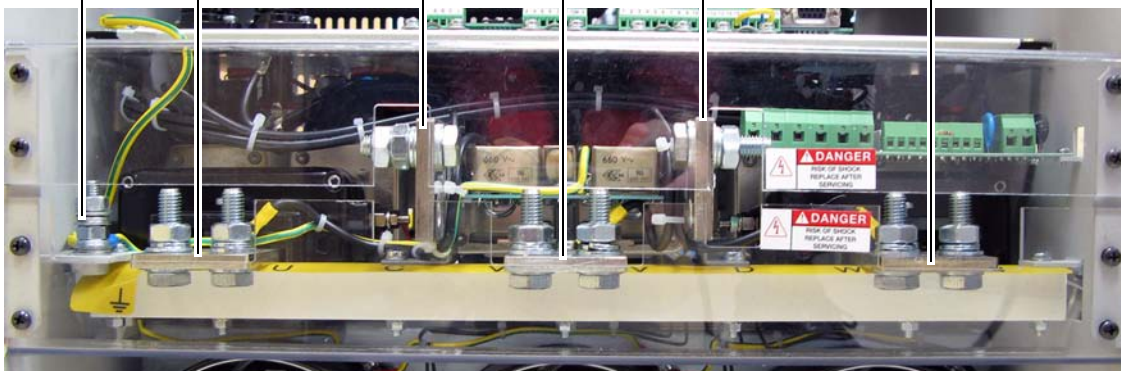

Bottom View

Frame D Armature Terminal Block Locations

Important: Certain frame D drives require the use of a terminal adapter kit(s) for terminals U, V, W, C and D. Refer to [Frame D Terminal Adapter Kits on page 16](#) for details.

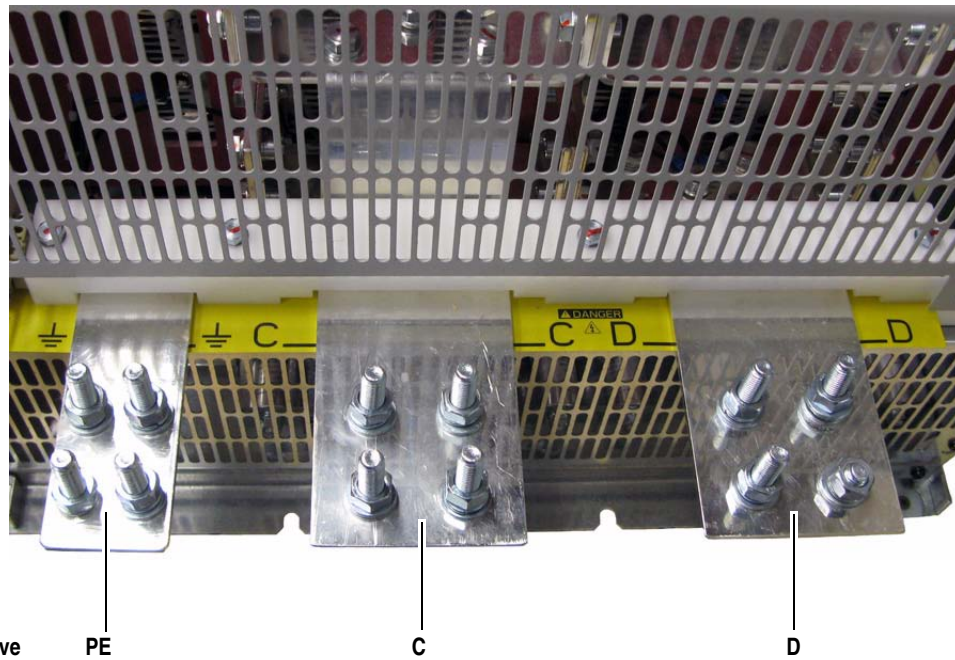
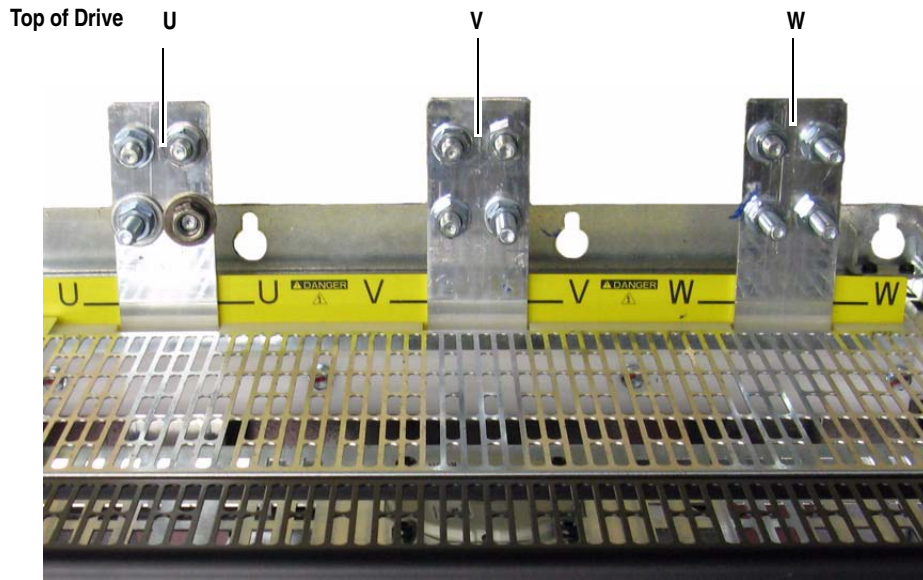

Armature Power Terminal and Ground (PE) Wire Sizes

Frame	Drive Current Rating Code ⁽¹⁾				Terminals	Wire Size and Type	Terminal Bolt Size (mm)	Tightening Torque N•m (lb•in)
	230V	460V	575	690				
A	7P0...055	4P1...052	–	–	U, V, W, C, D, PE	See “Cable and Wiring Recommendations” in the <i>PowerFlex Digital DC Drive User Manual</i> , publication 20P-UM001.	5	6 (53)
	073...110	073...129	–	–			Terminal Block	12 (106)
B	All	All	–	–	U, V, W, C, D PE		10	25 (221)
							8	15 (132.75)
C	All	All	–	–	U, V, W, C, D PE		10	25 (221)
							8	15 (132.75)
D	All	All	All	All	U, V, W, C, D, PE		12	45 (398.2)

⁽¹⁾ See [Catalog Number Explanation on page 6](#), positions 8, 9 and 10 for corresponding drive HP rating, armature amp rating and field amp rating.

Important: Certain frame D drives require the use of a terminal adapter kit(s) for terminals U, V, W, C and D. Refer to [Frame D Terminal Adapter Kits on page 16](#) for details.

Armature Voltage Feedback Connections

When a DC output contactor or inverting fault breaker/fuse is used with the drive, and a speed feedback device (tachometer or encoder) is not used, the Armature Voltage Feedback terminals can be used to monitor the armature voltage at the motor regardless of the state of the contactor or inverting fault device. When this terminal block is not connected to the motor armature terminals, the terminals must be jumpered (as described in the table below) and the armature voltage feedback is monitored internally within the drive. In this case, when a DC contactor is used with the drive, a speed feedback device is not used, and the contactor opens, the drive will no longer receive the armature voltage feedback signal.

Important: By default, these terminals are jumpered - 1A1 to A1 and 1A2 to A2. If these terminals are not wired to the motor terminals, the jumpers must be installed.

Note that this terminal block is not present on drives shipped from the factory prior to those with v3.001 firmware installed. However, new Pulse Transformer boards shipped as replacement parts from the factory will contain this terminal block and can be used with any version of firmware.

Terminals	Description
1A1	Jumpered to A1 when internal armature voltage feedback is used. Not used when A1 is connected to motor terminal A1.
A1	Voltage feedback from motor terminal A1.
1A2	Jumpered to A2 when internal armature voltage feedback is used. Not used when A2 is connected to motor terminal A2.
A2	Voltage feedback from motor terminal A2.

Armature Voltage Feedback Circuit Wire Sizes and Terminal Specifications

Frame	Terminals	Wire Size and Type ⁽¹⁾	Tightening Torque N•m (lb•in)
A, B & C	1A1, A1, 1A2, A2	24...10 AWG/kcmils	0.5...0.6 (4.4...5.3)
D		22...8 AWG/kcmils	0.8...1.6 (7.1...14.2)

⁽¹⁾ Wire with an insulation rating of 600V or greater is recommended. See “Cable and Wiring Recommendations” in the *PowerFlex Digital DC Drive User Manual*, publication 20P-UM001, for cable spacing information.

Frame A Armature Voltage Feedback Circuit Terminal Block Location

Bottom of View of Drives

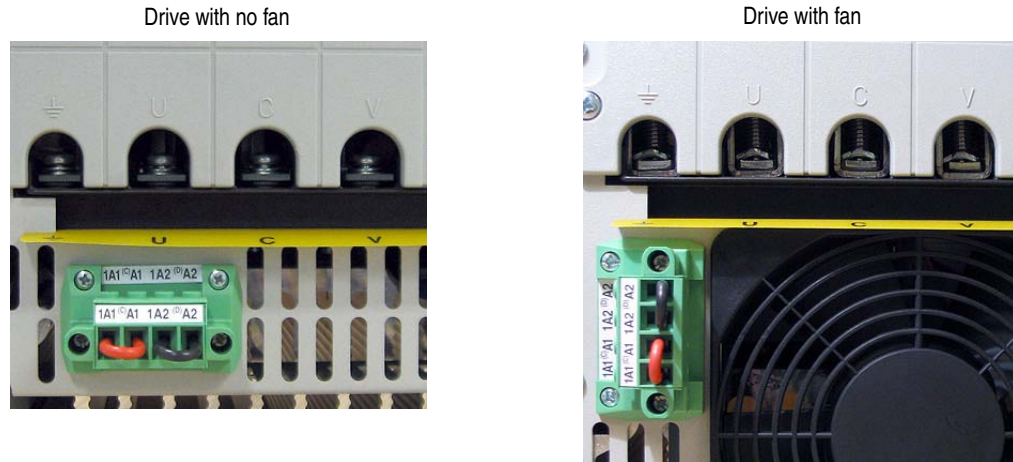

Shown with terminals jumpered for internal armature voltage feedback.

Frame B Armature Voltage Feedback Circuit Terminal Block Location



Top of Drive

Shown with terminals jumpered for internal armature voltage feedback.

Frame C Armature Voltage Feedback Circuit Terminal Block Location

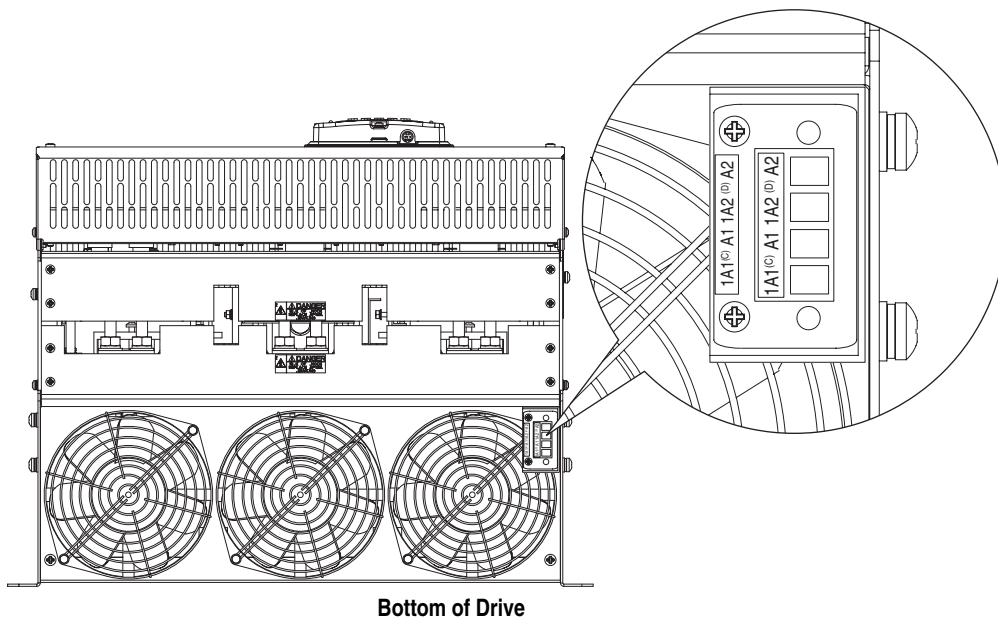

Frame D Armature Voltage Feedback Circuit Terminal Block Location

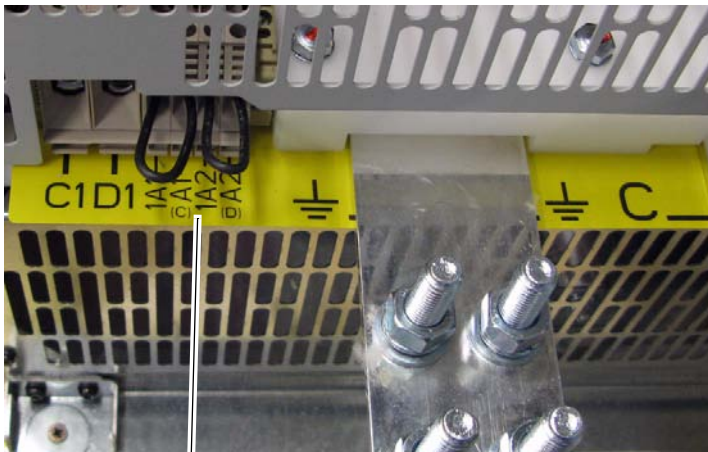

Shown with terminals jumpered for internal armature voltage feedback.

**Bottom of Drive,
Left Side**

Field Converter Connections

Field Converter Terminal Designations

Terminal	Description
U1, V1	Single-phase AC line input power to the field circuit.
C1, D1	DC output power to the motor field.

Frame A Field Circuit Terminal Block Location

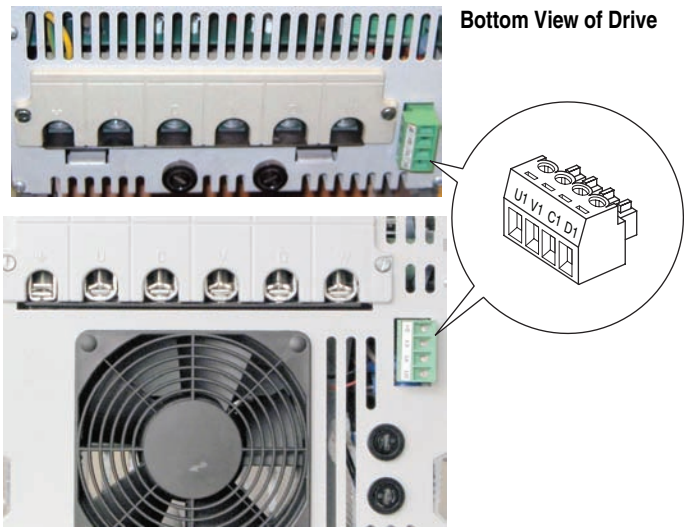

Frame B Field Circuit Terminal Block Location

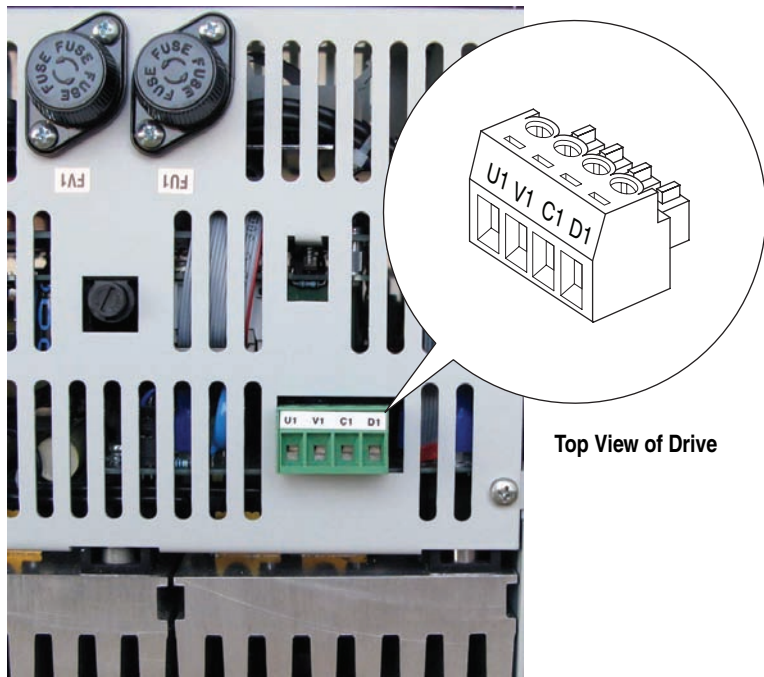

Frame C Field Circuit Terminal Block Location

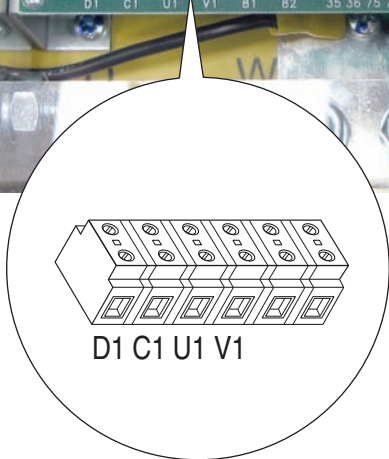
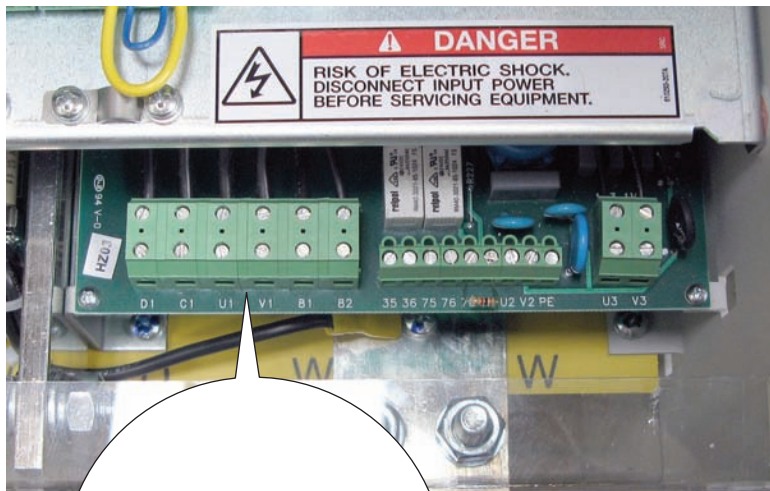

Front View of Drive

Frames A...C Field Circuit Wire Sizes and Terminal Specifications

Terminals	Wire Size and Type ⁽¹⁾	Tightening Torque N•m (lb•in)
U1, V1, C1, D1	24...10 AWG/kcmils	0.5...0.8 (4.4...7.1)

⁽¹⁾ See "Cable and Wiring Recommendations" in the *PowerFlex Digital DC Drive User Manual*, publication 20P-UM001, for cable spacing information.

Frame D Field Circuit Terminal Block Location

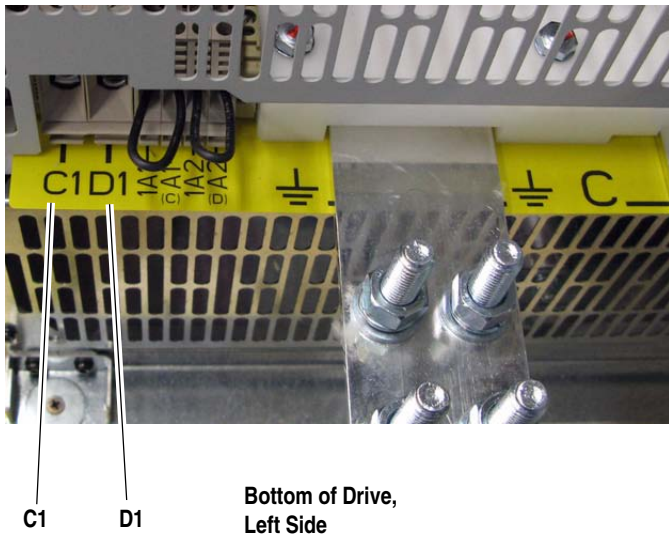
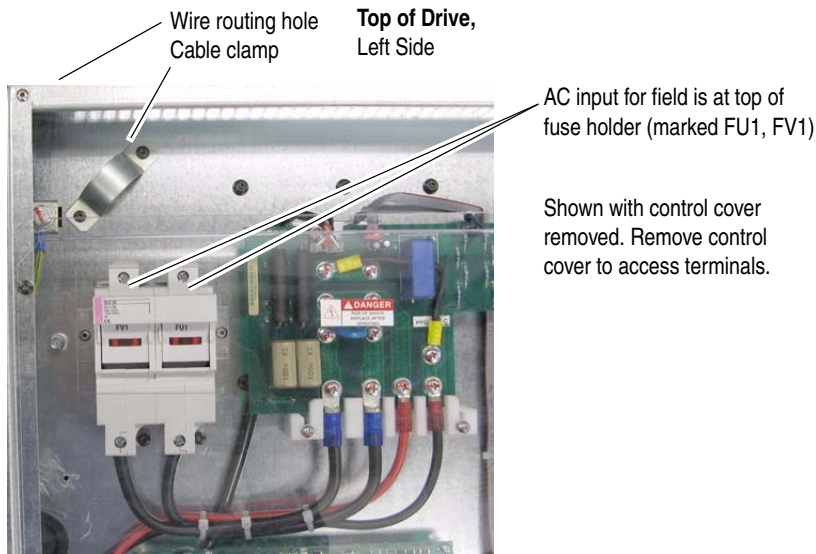

Frame D Field Circuit Wire Sizes and Terminal Specifications

Drive Current Rating Code ⁽¹⁾				Terminals	Wire Size ⁽²⁾	Tightening Torque N•m (lb•in)
230V	460V	575V	690V			
875	830	810	678	U1, V1, C1, D1	6 AWG	4.0 (35.4)
1K0	996	1K0	791			
–	–	1K2	904			
–	–	1K3	1K0			
–	–	1K6	–			
–	1K1	–	1K1			
–	1K3	–	1K2		2 AWG	
–	1K4	–	1K4			
–	–	–	1K5			
–	–	–	–			

(1) See [Catalog Number Explanation on page 6](#), positions 8, 9 and 10 for corresponding drive HP rating, armature amp rating and field amp rating.

(2) See "Cable and Wiring Recommendations" in the *PowerFlex Digital DC Drive User Manual*, publication 20P-UM001, for cable spacing information.

Control Circuit Input Power

The control circuit must be powered by an external 230V AC or 115V AC single phase power supply. For frame B and C drives only, a jumper is required between terminals SA and SB for 115V AC control input power. Refer to [SA-SB Terminal Block Location on Frame B Drives on page 34](#) and [SA-SB Terminal Block Location on Frame C Drives on page 35](#) for terminal block locations.

Control Circuit Terminal Designations

Terminal	Description
U2	Single-phase AC power for the control circuits.
V2	

Frame A Control Circuit Terminal Block Location

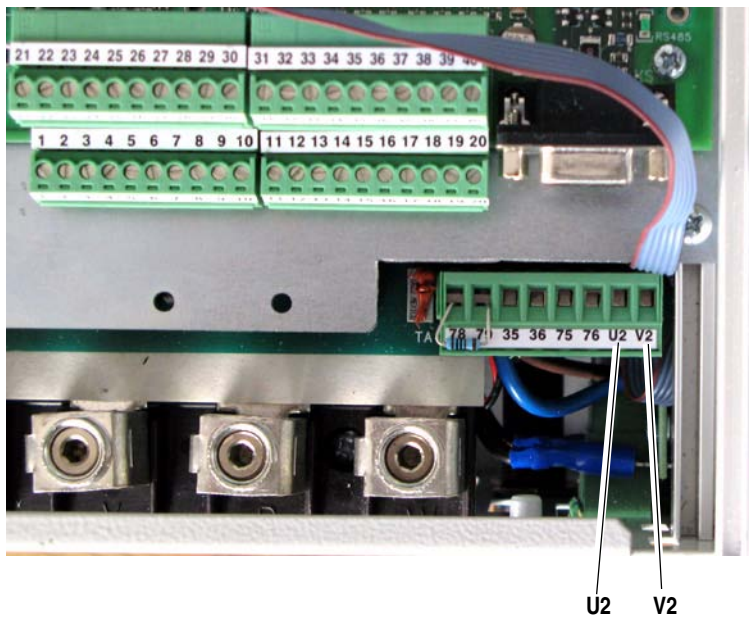

Frame B Control Circuit Terminal Block Location

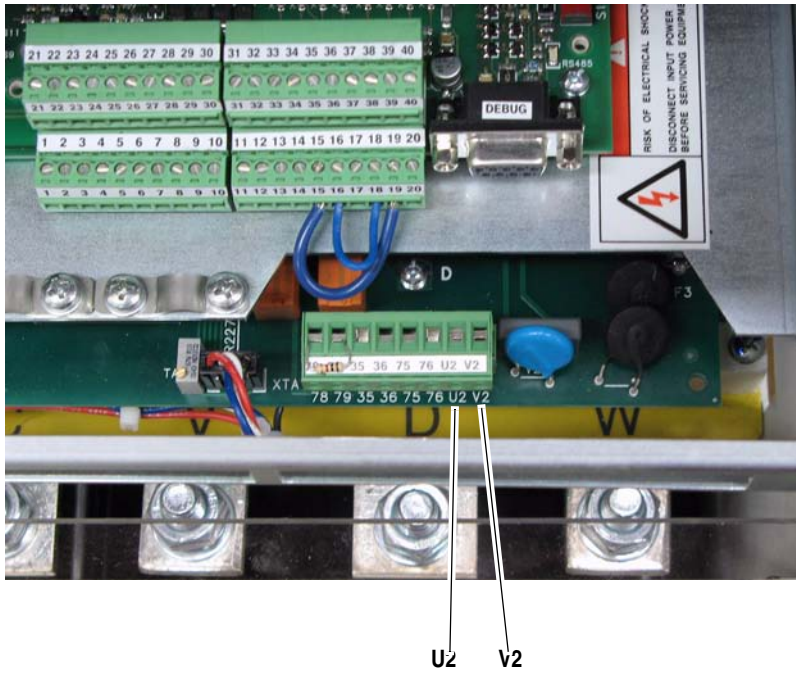

Frame C Control Circuit Terminal Block Location

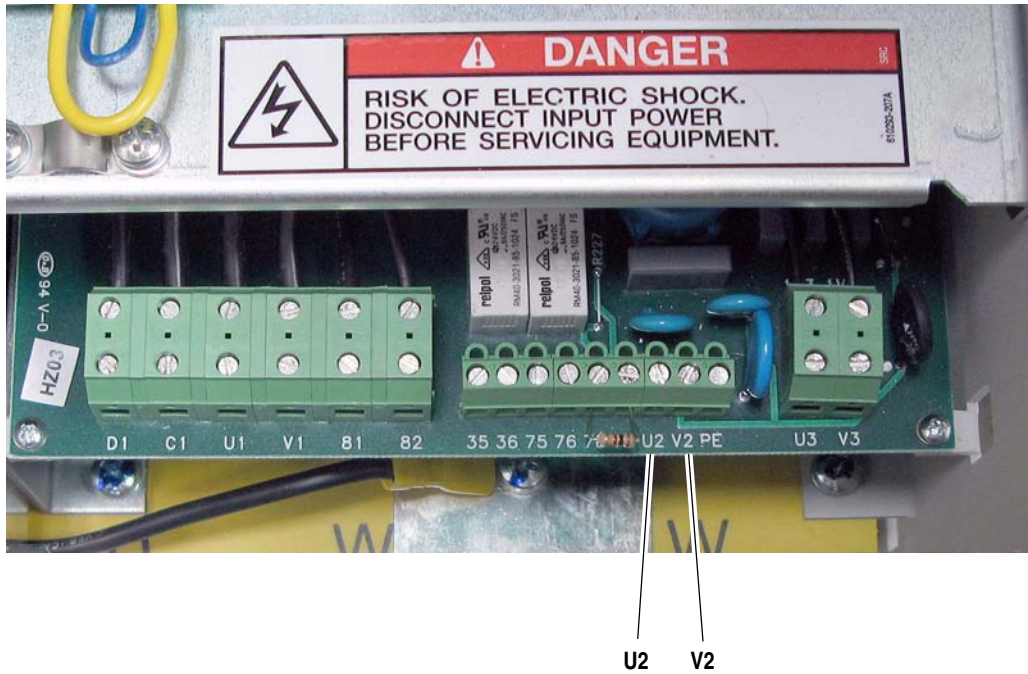

Frame D Control Circuit Terminal Block Location

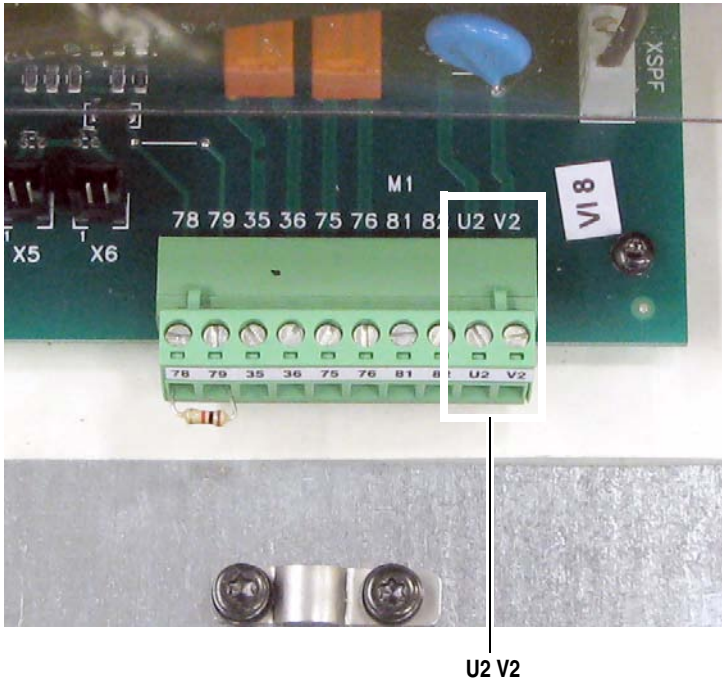

Control Circuit Wire Sizes

Terminals	Wire Size and Type ⁽¹⁾			Tightening Torque N•m (lb•in)
	Flexible (mm ²)	Multi-core (mm ²)	AWG	
U2, V2	0.14...1.5	0.14...2.5	26...14	0.5 (4.4)
PE	2.5...10	2.5...10	12...8	2.0 (18.0)

⁽¹⁾ See "Cable and Wiring Recommendations" in the *PowerFlex Digital DC Drive User Manual*, publication 20P-UM001, for cable spacing information.

SA-SB Terminal Block Location on Frame B Drives



SA-SB Terminal Block Location on Frame C Drives

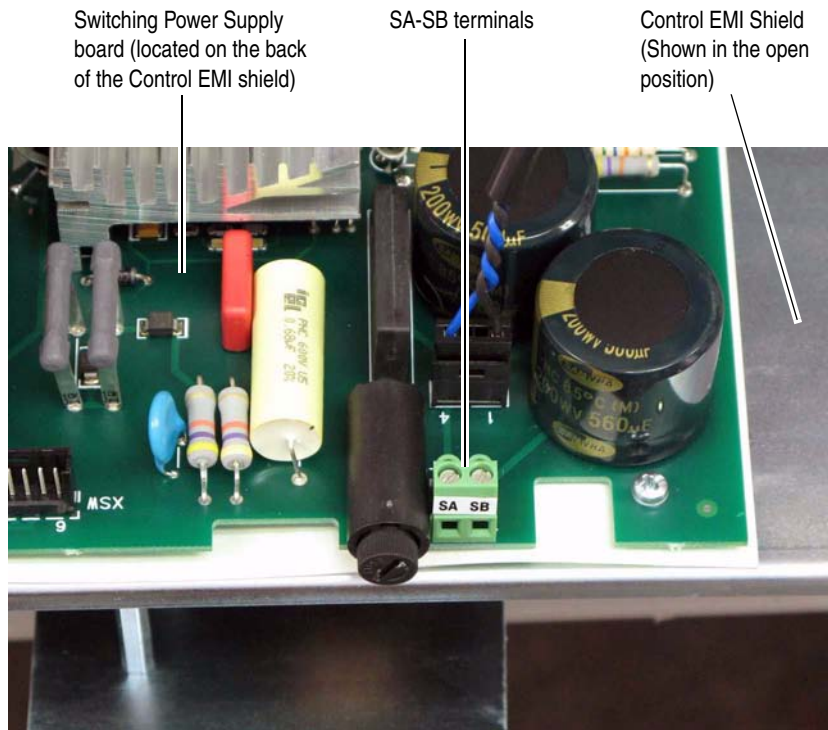

Front of drive shown with top protective cover removed. Control EMI shield

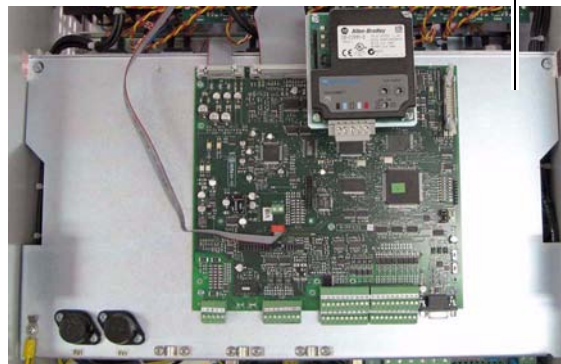

Frame C Heatsink Cooling Fans Power Supply Terminals

Frame C drives require an external 230V AC power supply for the heatsink cooling fans. The power supply connections must be taken from the primary side of the installed Isolation Transformer or Line Reactor (clean power). Refer to [Typical Power Wiring Diagrams on page 19](#).

In addition, the fan power input terminals U3 and V3 are required to be short circuit protected. This protection can be provided by using a circuit breaker. The circuit breaker must be selected to survive the short circuit available current of the feeder source for this circuit and the inrush current of the fan.

The rating of the circuit breaker should be sized mainly to protect the wiring from the circuit breaker connections to terminals U3 and V3, and not nuisance trip or blow from the inrush current.

Frame C Heatsink Cooling Fans Terminal Designations

Terminal	Description	Maximum Voltage	Maximum Current
U3	Single-phase AC input power for cooling fans.	230V AC	1 A
V3			

Frame C Heatsink Cooling Fans Wire Sizes and Terminal Specifications

Terminals	Wire Size and Type ⁽¹⁾			Tightening Torque N•m (lb•in)
	Flexible (mm ²)	Multi-core (mm ²)	AWG	
U3, V3	0.14...1.5	0.14...2.5	26...16	0.4 (3.5)

⁽¹⁾ See "Cable and Wiring Recommendations" in the *PowerFlex Digital DC Drive User Manual*, publication 20P-UM001, for cable spacing information.

Frame C Heatsink Cooling Fan Terminal Block Location

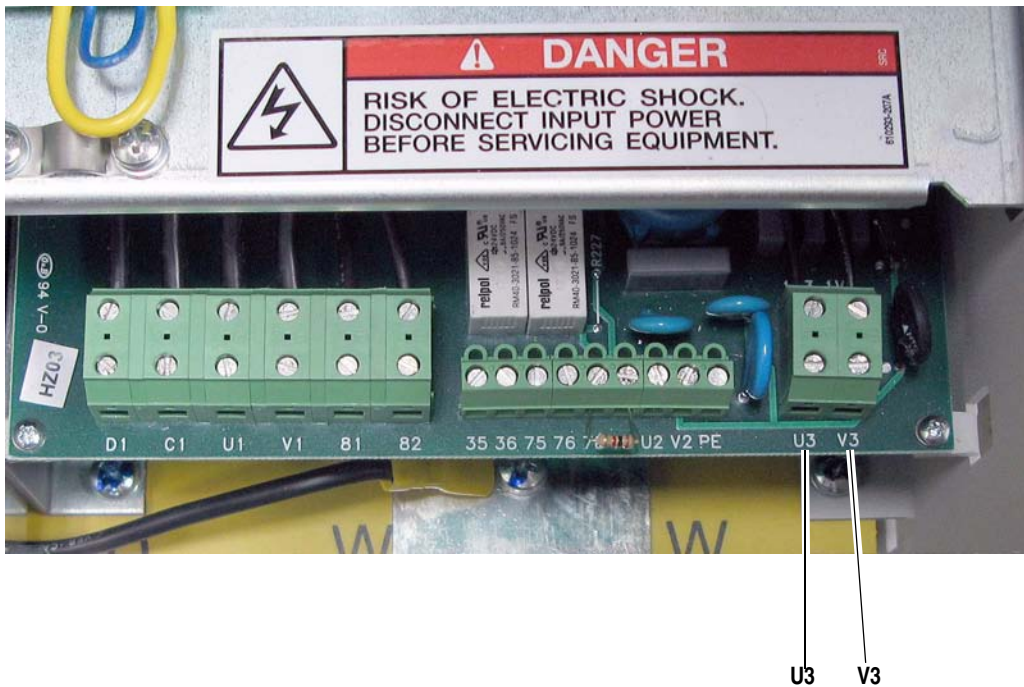

Frame D Heatsink Cooling Fan Power Supply Terminals

Frame D drives require an external 230V AC power supply for the heatsink cooling fan. The power supply connections must be taken from the primary side of the installed Isolation Transformer or Line Reactor (clean power). Refer to [Typical Power Wiring Diagrams on page 19](#).

The fan power input terminals U3 and V3 are required to be short circuit protected. This protection can be provided by using a circuit breaker. The circuit breaker must be selected to survive the short circuit available current of the feeder source for this circuit and the inrush current of the fan.

The rating of the circuit breaker should be sized mainly to protect the wiring from the circuit breaker connections to terminals U3 and V3, and not nuisance trip or blow from the inrush current.

In addition, a N.C. contact (at terminals 31 and 32) can be connected to an external device to provide indication of a fan supply failure or can be wired to drive digital input terminals configured for 14 “Aux Fault” (via Pars133...144).

Frame D Heatsink Cooling Fan Terminal Designations

Terminal	Description	Maximum Voltage	Maximum Current
U3	Single-phase AC input power for cooling fans.	230V AC	2.4...3.3 A
V3			(50/60 Hz)
31	Normally closed contact.	250V AC	1 A
32			
PE	Safety ground		

Frame D Heatsink Cooling Fan Signal Wire Sizes and Terminal Specifications

Terminals	Wire Size and Type ⁽¹⁾			Tightening Torque N*m (lb*in)
	Flexible (mm ²)	Multi-core (mm ²)	AWG	
U3, V3, 31, 32, PE	0.14...1.5	0.14...2.5	28...12	0.5...0.6 (4.4...5.3)

⁽¹⁾ See "Cable and Wiring Recommendations" in the *PowerFlex Digital DC Drive User Manual*, publication 20P-UM001, for cable spacing information.

Frame D Heatsink Cooling Fan Terminal Block Location

Top of Drive,
Left Side

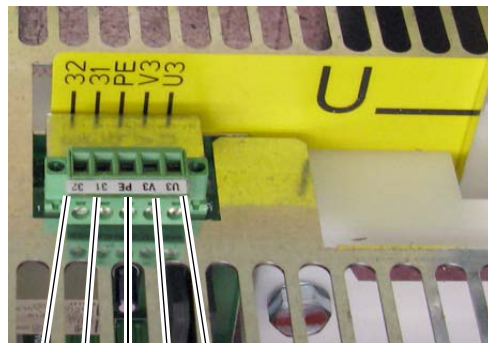

32 31 PE V3 U3

Frame C and D Armature Fuse Signal Terminals

Terminals 81 and 82 on frame C and D drives are connected to the internal armature circuit protection fuses and can be connected to an external device to provide indication that the fuses have opened. Alternatively, terminals 81 and 82 can be wired to drive digital input terminals configured for 64 “Invert Flt” (via Pars 133...144).

Armature Fuse Signal Terminal Designations

Terminal	Description	Maximum Voltage	Maximum Current
81	Internal armature fuse intervention signal.	250V AC	1 A
82			

Armature Fuse Signal Wire Size and Terminal Specifications

Terminals	Wire Size and Type ⁽¹⁾			Tightening Torque N•m (lb•in)
	Flexible (mm ²)	Multi-core (mm ²)	AWG	
81, 82	0.14...1.5	0.14...2.5	26...16	0.4 (3.5)

⁽¹⁾ See “Cable and Wiring Recommendations” in the *PowerFlex Digital DC Drive User Manual*, publication 20P-UM001, for cable spacing information.

Frame C Internal Armature Fuse Signal Terminal Block Location



Frame D Internal Armature Fuse Signal Terminal Block Location

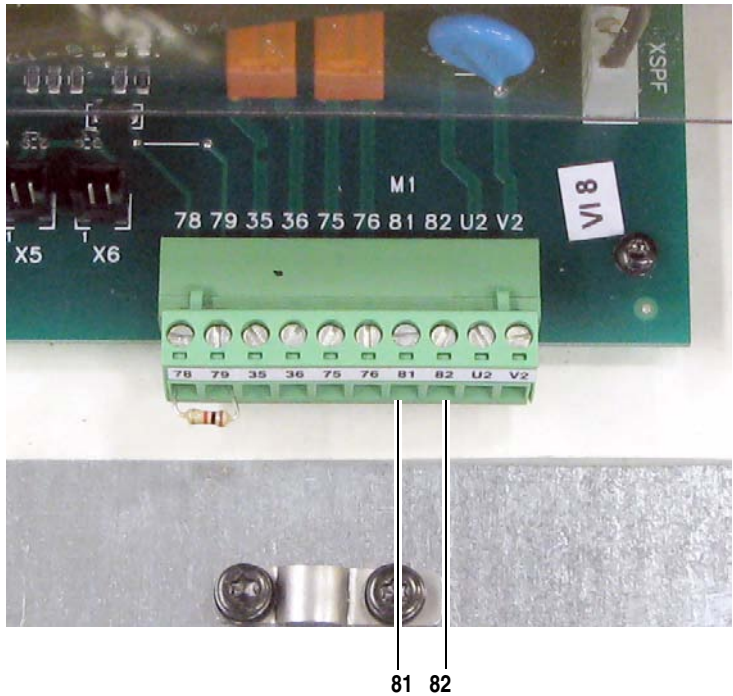

Relay Outputs

Terminals 35 and 36 and 75 and 76 are N.O. relay outputs. The relay output between terminals 35 and 36 is configured with parameter 1392 [Relay Out 1 Sel]. The relay output between terminals 75 and 76 is configured with parameter 629 [Relay Out 2 Sel]. Refer to “Using Contactors” in the *PowerFlex Digital DC Drive User Manual*, publication 20P-UM001..., for more information.

Thermistors and Thermal Switches

To detect motor overheating and protect the motor from overloading, an external, user-supplied thermistor (PTC) or thermal switch must be connected to terminals 78 and 79. The drive’s response to a motor over temperature fault is configured in parameter 365 [OverTemp Flt Cfg]. If a temperature sensor is not used, a 1k ohm resistor must be connected between terminals 78 and 79 (installed at the factory). The instructions for installing a thermal sensor are detailed below.

Thermistors (PTC)

PTC thermistors fitted in the motor can be connected directly to the drive via terminals 78 and 79. In this case the 1k ohm resistor is not required between terminals 78 and 79.

Thermal Switches (Klixon®) in the Motor Windings

“Klixon” type temperature-dependent contacts can disconnect the drive from the motor via an external control or can be configured as an external fault using a digital input on drive. They can also be connected to terminals 78 and 79 in order to indicate a drive “Motor Over Temp” fault (F16), though this is not recommended due to the noise sensitivity of the current threshold circuitry. If a thermal switch is used a 1k ohm resistor must be placed in series between the switch and one of the terminals.

Contact Relay and Thermistor Terminal Designations

Terminal	Description
35	Normally open contact. Configured with parameter 1392 [Relay Out 1 Sel] - set to 25 "Contactor" by default.
36	
75	Normally open contact. Configured with parameter 629 [Relay Out 2 Sel] - set to 5 "Ready" by default.
76	
78	Motor thermistor connections (PTC)
79	

Frame A Contact Relay and Thermistor Terminal Block Locations

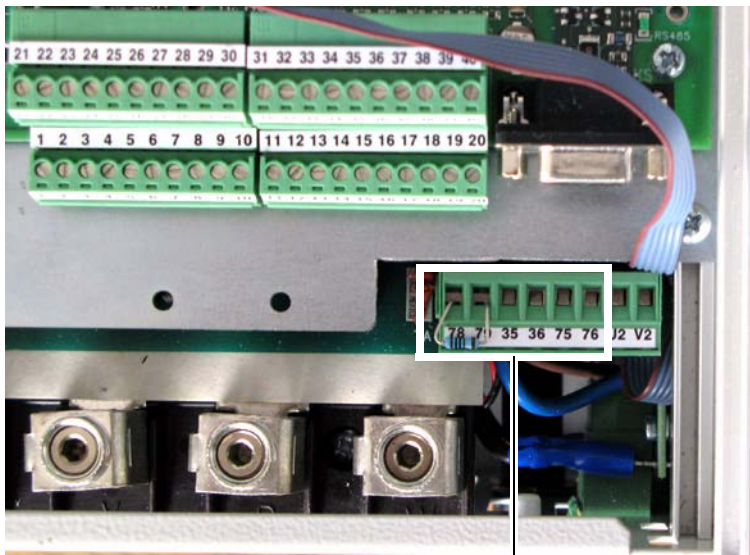

Note: Terminals 78 and 79 shown with 1k ohm resistor in place of temperature sensor.

78 79 35 36 75 76

Frame B Contact Relay and Thermistor Terminal Block Locations

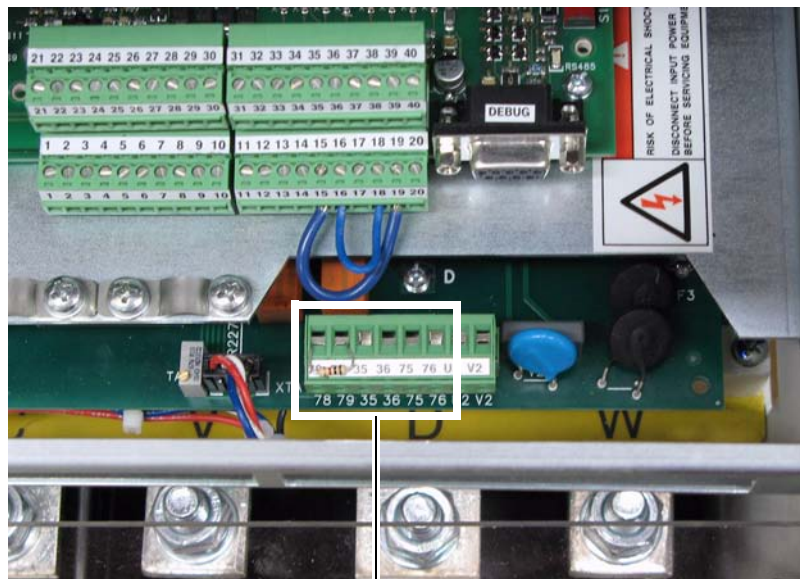

78 79 35 36 75 76

Frame C Contact Relay and Thermistor Terminal Block Locations



Frame D Contact Relay and Thermistor Terminal Block Locations

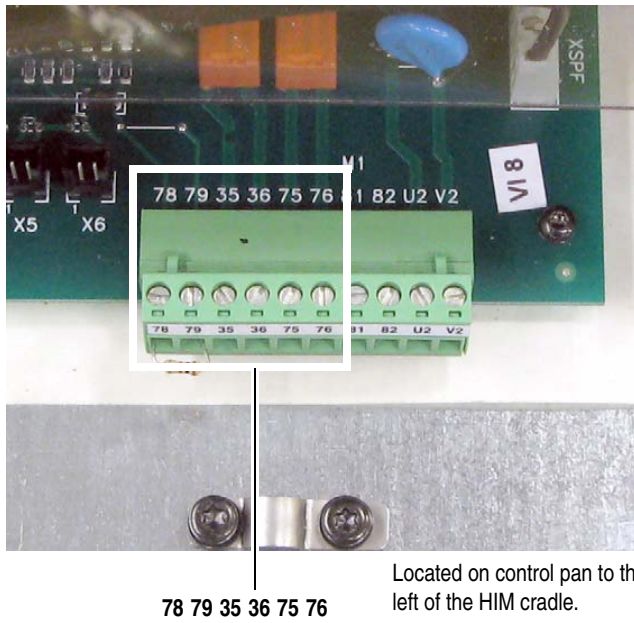

Recommended Signal Wire Size for Relay Outputs and Thermistor/Thermal Switch Terminals

Signal Type	Terminals	Wire Size and Type ⁽¹⁾			Tightening Torque N•m (lb•in)
		Flexible (mm ²)	Multi-core (mm ²)	AWG	
Relay Outputs	35 & 36, 75 & 76	0.140...1.500	0.140...1.500	26...14	0.5 (4.4)
Thermistor and Thermal Switches	78 & 79				

⁽¹⁾ See "Cable and Wiring Recommendations" in the *PowerFlex Digital DC Drive User Manual*, publication 20P-UM001, for cable spacing information.

I/O Signal and Control Wiring

Eight (8) digital inputs, four (4) digital outputs, three (3) analog inputs, and two (2) analog outputs are available on the standard I/O terminal blocks provided with the drive. One digital input (1-8) must be configured for “Enable”.

Additional digital and analog I/O is available when using the optional I/O Expansion circuit board. Refer to Appendix F - “Optional Analog and Digital I/O Expansion Circuit Board”, in the *PowerFlex Digital DC Drive User Manual*, publication 20P-UM001..., for more information. Also, you can use the optional 115V AC Converter circuit board to convert 115V AC digital input signals to 24V DC digital inputs signals to interface with the digital inputs on the standard I/O terminal blocks. Refer to Appendix G - “Optional 115V AC to 24V DC I/O Converter Circuit Board” in the *PowerFlex Digital DC Drive User Manual*, publication 20P-UM001..., for more information. All I/O terminal blocks are located on the control board.

I/O Terminal Block Locations

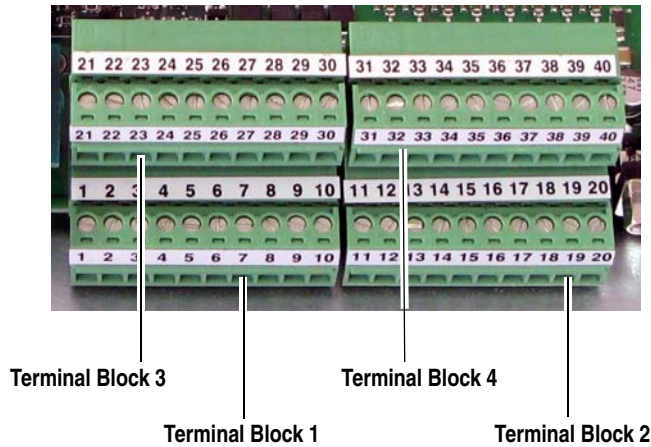

I/O Terminal Block 1 Designations

No.	Signal	Description	Factory Default	Related Parameter
1	Analog Input 1 (+)	Isolated ⁽¹⁾ , bipolar, differential, ±10V / 0-20mA, or 4-20mA. Important: 0-20mA or 4-20mA operation requires that switch S9, S10, and S11 on the Control board be in the “Off” position. Drive damage may occur if the switch is not in the correct position based on the type of input signal. Refer to “DIP Switch and Jumper Settings” in the <i>PowerFlex Digital DC Drive User Manual</i> , publication 20P-UM001... Max ±10V, Max 0.25mA.	1 “Speed Ref A”	70 [Anlg In1 Sel]
2	Analog Input 1 (-)		0 “Off”	75 [Anlg In2 Sel]
3	Analog Input 2 (+)		0 “Off”	80 [Anlg In3 Sel]
4	Analog Input 2 (-)			
5	Analog Input 3 (+)			
6	Analog Input 3 (-)			
7	+10V Pot Reference	2-5k ohm load. Max ±10V, Max 10mA.	-	-
8	-10V Pot Reference			
9	Pot Common	For (+) and (-) 10V pot references.	-	-
10	PE ground	PE ground to drive chassis.	-	-

⁽¹⁾ Differential Isolation - External source must be maintained at less than 160V with respect to PE. Input provides high common mode immunity.

I/O Terminal Block 2 Designations

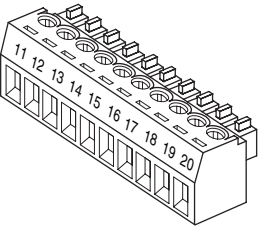

No.	Signal	Description	Factory Default	Related Parameter
11	Internal 0V		–	–
12	Digital Input 1	Max Volt. +30V, Max Cur. 15V/3.2mA, 24V/5mA, and 30V/6.4mA.	2 “Stop/CF”	133 [Digital In1 Sel]
13	Digital Input 2		3 “Start”	134 [Digital In2 Sel]
14	Digital Input 3		11 “Jog”	135 [Digital In3 Sel]
15	Digital Input 4		1 “Enable” ⁽¹⁾	136 [Digital In4 Sel]
16	Digital Input Common ⁽²⁾		–	–
17	Not Used		–	–
18	24V Supply Common	Common for the internal power supply.	–	–
19	+24V DC Supply	Drive supplied control input power. Max. +20-30V, 200mA ⁽³⁾	–	–
20	PE ground	PE ground to drive chassis.	–	–

- (1) A digital input (1-8) must be configured for “Enable”.
- (2) When using the internal +24V DC supply (terminal 19) for digital inputs 1-4, you must connect the digital input common (terminal 16) to the +24V supply common (terminal 18).
- (3) The total current draw is the sum of encoder power, digital outputs and any other loads connected to terminal 19.

I/O Terminal Block 3 Designations

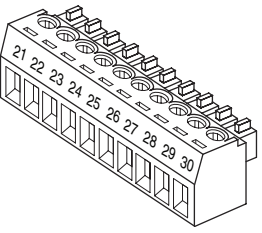

No.	Signal	Description	Factory Default	Related Parameter
21	Analog Output 1 (+)	Max. ±10V, Max. 5 mA.	12 “Motor Speed”	66 [Anlg Out1 Sel]
22	Analog Output 1 (–)			
23	Analog Output 2 (+)		13 “Motor Curr”	67 [Anlg Out2 Sel]
24	Analog Output 2 (–)			
25	Digital Output Common		–	–
26	Digital Output 1	Max. +30V, Max 50mA	5 “Ready”	145 [Digital Out1 Sel]
27	Digital Output 2		9 “Fault”	146 [Digital Out2 Sel]
28	Digital Output 3		2 “Spd Thresh”	147 [Digital Out3 Sel]
29	Digital Output 4		4 “CurrentLimit”	148 [Digital Out4 Sel]
30	+24VDC	Drive supplied power for Digital Outputs. Max. ±80V, Max. 80mA.	–	–

I/O Terminal Block 4 Designations

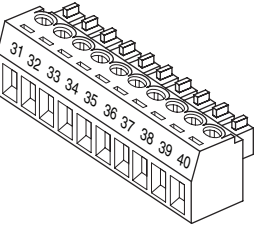

No.	Signal	Description	Factory Default	Related Parameter
31	Digital Input 5	Max Volt. +30V, Max Cur. 15V/3.2mA, 24V/5mA, and 30V/6.4mA.	17 “Speed Sel 1”	137 [Digital In5 Sel]
32	Digital Input 6		18 “Speed Sel 2”	138 [Digital In6 Sel]
33	Digital Input 7		19 “Speed Sel 3”	139 [Digital In7 Sel]
34	Digital Input 8		31 “Contactor”	140 [Digital In8 Sel]
35	Digital Input Common	Important: When using the internal +24V DC supply (terminal 19) for digital inputs 5-8, you must connect the digital input common (terminal 35) to the +24V supply common (terminal 18).	–	–
36-40	Not Used		–	–

Recommended Signal Wire Size for Analog I/O and Digital I/O

Signal Type	Terminal Block (Terminals)	Wire Size and Type ⁽¹⁾			Tightening Torque N•m (lb•in)
		Flexible (mm ²)	Multi-core (mm ²)	AWG	
Analog and Digital I/O	TB1...4 (1...40)	0.140...1.500	0.140...1.500	26...16	0.4 (3.5)

(1) See “Cable and Wiring Recommendations” in the *PowerFlex Digital DC Drive User Manual*, publication 20P-UM001, for cable spacing information.

Digital Encoder Terminal Block

The encoder connection cables should always be connected directly to the terminals on the encoder terminal block. The encoder cable must be made up of twisted pairs with the shield connected to the shield ground on the drive side. Do not connect the shield to ground on the motor side. In some cases (i.e., cable lengths that exceed 100 meters), it may be necessary to ground the shield of each twisted pair on the power supply. Refer to Appendix A of the *PowerFlex Digital DC Drive User Manual*, publication 20P-UM001..., for Digital Encoder specifications.

Digital Encoder Terminal Designations

No.	Description	
A+	Encoder A	Single channel or quadrature A input
A-	Encoder A (NOT)	
B+	Encoder B	Dual channel quadrature B input
B-	Encoder B (NOT)	
Z+	Encoder Z	Pulse, marker or registration input ⁽²⁾
Z-	Encoder Z (NOT)	
COM	+5/12-15V ⁽¹⁾ DC Return	Internal power common
+V	+5/12-15V ⁽¹⁾ DC Power	Internal power source 200 mA

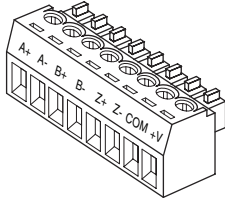

- ⁽¹⁾ Selectable via switch S21 on the Control board. Refer to "DIP Switch and Jumper Settings" in the *PowerFlex Digital DC Drive User Manual*, publication 20P-UM001..., for more information.
- ⁽²⁾ Selectable via switch S20 on the Control board. Refer to "DIP Switch and Jumper Settings" in the *PowerFlex Digital DC Drive User Manual*, publication 20P-UM001..., for more information.

Digital Encoder Terminal Block Location

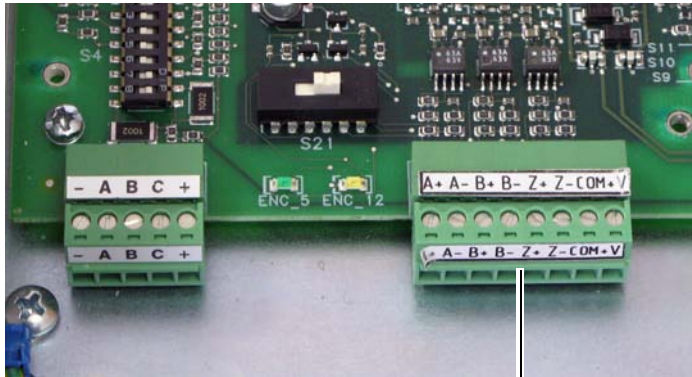

Digital Encoder terminal block

Sample Encoder Wiring

I/O	Connection Example
<p>Encoder Power – (1) Internal Drive Power Internal (drive) +5/12-15V DC, 200mA</p>	
<p>Encoder Power –External Power Source</p>	
<p>Encoder Signal –Single-Ended, Dual Channel</p>	
<p>Encoder Signal –Differential, Dual Channel</p>	

(1) Shield connection is on the drive Control EMI Shield. Refer to [Digital Encoder Terminal Block Location on page 44](#).

DC Analog Tachometer Terminal Block



ATTENTION: The Drive can overspeed if DIP switch S4 is set incorrectly, or the tachometer is wired incorrectly. Failure to observe this precaution could result in damage to, or destruction of, the equipment.

DC Analog Tachometer Terminal Designations

No.	Signal	Description
-	Negative input	-
A	(Not Used)	
B		
C		
+	Positive input Feedback polarity is determined during the start up routine.	22.7 / 45.4 / 90.7 / 181.6 / 302.9V ⁽¹⁾ max voltage 8 mA max. current

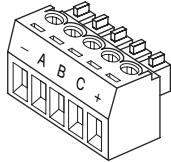

⁽¹⁾ Maximum voltage depends on the configuration of DIP switch S4. Refer to the *PowerFlex® Digital DC Drive User Manual*, publication 20P-UM001... for information on jumper settings.

Analog Tachometer Terminal Block Location

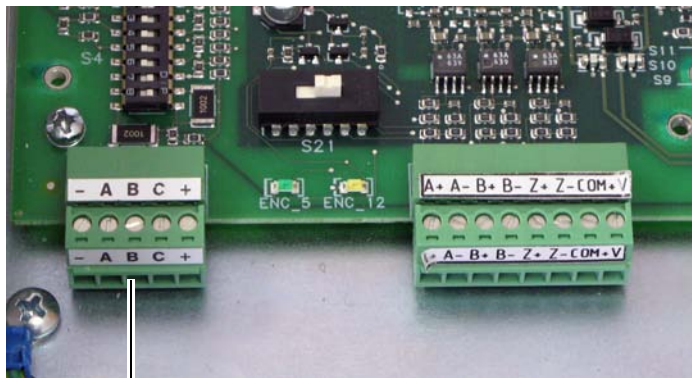

Analog Tachometer terminal block

Recommended Signal Wire Size for DC Analog Tachometer

Signal Type	Terminal Block (Terminals)	Wire Type and Size ⁽¹⁾			Tightening Torque N•m (lb•in)
		Flexible (mm ²)	multi-core (mm ²)	AWG	
DC Analog Tach	M3 (+ and -)	0.140...1.500	0.140...1.500	26...16	0.4 (3.5)

⁽¹⁾ See "Cable and Wiring Recommendations in the *PowerFlex Digital DC Drive User Manual*, publication 20P-UM001...

Circuit Protection

The tables on the following pages provide drive ratings and the recommended fuses for protecting the armature and field circuits. Externally mounted fuses (as indicated in the figures below) must be sourced separately when installing the drive. Internally mounted fuses are provided with the drive.

Frame A and B Fuse Designations

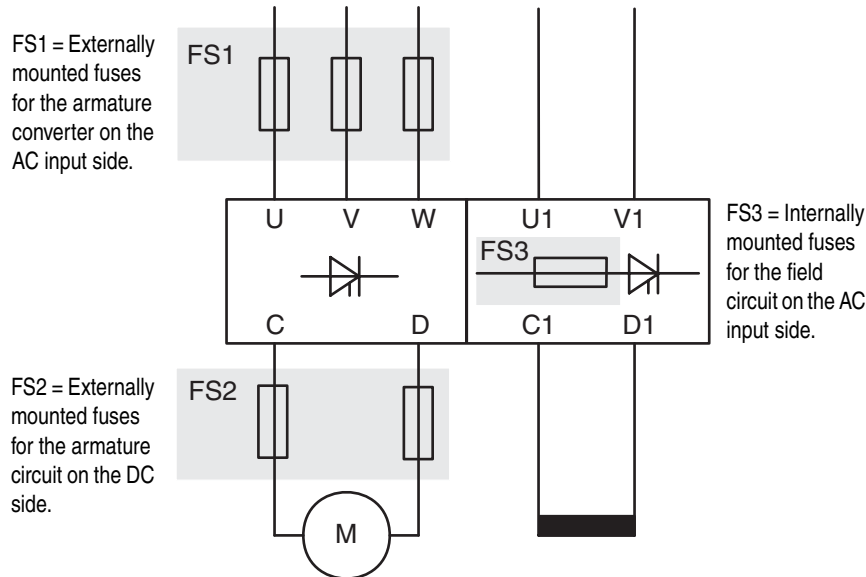

Frame A and B Recommended AC Input Line Fuses

230V AC Input Drives

Frame	Drive Current Rating Code	DC Amps	AC Line Amps	Fuse Code FS1 (See Frame A and B Fuse Designations above)					
				Bussmann			Ferraz Shawmut (Gould Shawmut)		
				Ferrule FWP Type	Ferrule Fuse Block	North American FWP Type	North American Fuse Block	Ferrule A70QS Type	North American A70P / A70QS Type
A	7P0	7	5.7	FWP-10A14F	CH143D	FWP-10B	-	A70QS10-14F	A70P10-4
	9P0	9	7.4	FWP-15A14F		FWP-15B	-	A70QS16-14F	A70P15-4
	012	12	9.8	FWP-20A14F		FWP-20B	-	A70QS20-14F	A70P20-4
	020	20	16	FWP-25A14F		FWP-25B	-	A70QS25-14F	A70QS25-4
	029	29	24	FWP-40A22F	CH223D	FWP-40B	-	A70QS40-22F	A70QS40-4
	038	38	31	FWP-63A22F		FWP-60B	-	A70QS63-22F	A70QS60-4
	055	55	45	FWP-80A22F		FWP-80B	-	A70QS80-22F	A70QS80-4
	073	73	60	-	-	FWP-100A	ST14	-	A70QS100-4K
	093	93	76	-	-	FWP-150A		-	A70QS150-4K
	110	110	90	-	-	FWP-175A		-	A70QS175-4K
B	146	146	119	-	-	FWP-250A		-	A70QS250-4
	180	180	147	-	-	FWP-300A	-	A70QS300-4	
	218	218	178	-	-	FWP-350A	-	A70QS350-4	
	265	265	217	-	-	FWP-400A	ST38-72612	-	A70QS400-4
	360	360	294	-	-	FWP-600A		-	A70QS600-4K
	434	434	355	-	-	FWP-600A		-	A70QS600-4

460V AC Input Drives

Frame	Drive Current Rating Code	DC Amps	AC Line Amps	Fuse Code FS1 (See Frame A and B Fuse Designations on page 47)					
				Bussmann				Ferraz Shawmut (Gould Shawmut)	
				Ferrule FWP Type	Ferrule Fuse Block	North American FWP Type	North American Fuse Block	Ferrule A70QS Type	North American A70P / A70QS Type
A	4P1	4.1	3.3	FWP-10A14F	CH143D	FWP-10B	–	A70QS10-14F	A70P10-4
	6P0	6	4.9	FWP-10A14F		FWP-10B	–	A70QS10-14F	A70P10-4
	010	10	8.2	FWP-20A14F		FWP-20B	–	A70QS20-14F	A70P25-4
	014	14	11.4	FWP-25A14F		FWP-25B	–	A70QS25-14F	A70P25-4
	019	19	15.5	FWP-25A14F		FWP-25B	–	A70QS25-14F	A70P25-4
	027	37	22.1	FWP-40A22F	CH223D	FWP-40B	–	A70QS40-22F	A70QS40-4
	035	35	28.6	FWP-63A22F		FWP-60B	–	A70QS63-22F	A70QS60-4
	045	45	36.8	FWP-80A22F		FWP-80B	–	A70QS80-22F	A70QS80-4
	052	52	42.5	FWP-80A22F		FWP-80B	–	A70QS80-22F	A70QS80-4
	073	73	59.6	–	–	FWP-100A	ST14	–	A70QS100-4K
	086	86	70.3	–	–	FWP-150A		–	A70QS150-4K
	100	100	81.7	–	–	FWP-175A		–	A70QS175-4K
	129	129	105.4	–	–	FWP-175A		–	A70QS175-4K
B	167	167	136.4	–	–	FWP-300A		–	A70QS300-4
	207	207	169.1	–	–	FWP-350A	–	A70QS350-4	
	250	250	204.3	–	–	FWP-400A	ST38-72612	A70QS400-4	
	330	330	269.6	–	–	FWP-600A		A70QS600-4K	
	412	412	336.6	–	–	FWP-600A		A70QS600-4	

Frame A and B Recommended Armature DC Output Fuses

230V AC Input Drives

Frame	Drive Current Rating Code	DC Amps	AC Line Amps	Fuse Code FS2 ⁽¹⁾ (See Frame A and B Fuse Designations on page 47)					
				Bussmann				Ferraz Shawmut (Gould Shawmut)	
				Ferrule FWP Type	Ferrule Fuse Block	North American FWP Type	North American Fuse Block	Ferrule A70QS Type	North American A70P / A70QS Type
A	7P0	7	5.7	FWP-15A14F	CH142D	FWP-15B	–	A70QS16-14F	A70P15-4
	9P0	9	7.4	FWP-20A14F		FWP-20B	–	A70QS20-14F	A70P20-4
	012	12	9.8	FWP-25A14F		FWP-25B	–	A70QS25-14F	A70P25-4
	020	20	16	FWP-40A14F		FWP-40B	–	A70QS40-14F	A70QS40-4
	029	29	24	FWP-63A22F	CH222D	FWP-60B	–	A70QS63-22F	A70QS60-4
	038	38	31	FWP-80A22F		FWP-80B	–	A70QS80-22F	A70QS80-4
	055	55	45	–		–	FWP-125A	ST14	A70QS125-4K
	073	73	60	–	–	FWP-150A	A70QS150-4K		
	093	93	76	–	–	FWP-200A	A70QS200-4K		
	110	110	90	–	–	FWP-225A	A70QS250-4		
	B	146	146	119	–	–	FWP-300A		–
180		180	147	–	–	FWP-350A	–	A70QS350-4	
218		218	178	–	–	FWP-450A	ST38-72612	A70QS450-4	
265		265	217	–	–	FWP-600A		A70QS600-4K	
360		360	294	–	–	FWP-700A		A70QS700-4	
434		434	355	–	–	FWP-900A	–	A70P900-4	

⁽¹⁾ Required on four quadrant drives only, highly recommended on two quadrant drives.

460V AC Input Drives

Frame	Drive Current Rating Code	DC Amps	AC Line Amps	Fuse Code FS2 ⁽¹⁾ (See Frame A and B Fuse Designations on page 47)					
				Bussmann			Ferraz Shawmut (Gould Shawmut)		
				Ferrule FWP Type	Ferrule Fuse Block	North American FWP Type	North American Fuse Block	Ferrule A70QS Type	North American A70P / A70QS Type
A	4P1	4.1	3.3	FWP-10A14F	CH142D	FWP-10B	–	A70QS10-14F	A70P10-4
	6P0	6	4.9	FWP-15A14F		FWP-15B	–	A70QS16-14F	A70P15-4
	010	10	8.2	FWP-20A14F		FWP-20B	–	A70QS20-14F	A70P20-4
	014	14	11.4	FWP-30A14F		FWP-30B	–	A70QS32-14F	A70P30-4
	019	19	15.5	FWP-40A14F		FWP-40B	–	A70QS40-14F	A70QS40-4
	027	37	22.1	FWP-63A22F	CH222D	FWP-60B	–	A70QS63-22F	A70QS60-4
	035	35	28.6	FWP-80A22F		FWP-70B	–	A70QS80-22F	A70QS70-4
	045	45	36.8	FWP-100A22F		FWP-90B	–	–	A70QS90-4
	052	52	42.5	FWP-100A22F		FWP-100B	–	–	A70QS100-4
	073	73	59.6	–		–	FWP-150A	ST14	–
	086	86	70.3	–	–	FWP-175A	–		A70QS175-4K
	100	100	81.7	–	–	FWP-200A	–		A70QS200-4K
129	129	105.4	–	–	FWP-250A	–	A70QS250-4		
B	167	167	136.4	–	–	FWP-350A	–		A70QS350-4
	207	207	169.1	–	–	FWP-400A	–	A70QS400-4	
	250	250	204.3	–	–	FWP-500A	ST38-72612	–	A70QS500-4K
	330	330	269.6	–	–	FWP-700A		–	A70QS700-4
	412	412	336.6	–	–	FWP-800A		–	A70QS800-4

(1) Required on four quadrant drives only, highly recommended on two quadrant drives.

Frame A and B Recommended Field Circuit Fuses

230V AC Input Drives

Frame	Drive Current Rating Code	Field Amps	Type	Fuse Code FS3 ⁽¹⁾ (See Frame A and B Fuse Designations on page 47 and Frame A Field AC Input Line Fuses Location on page 50 and Frame B Field AC Input Line Fuses Location on page 51 for location.)		
				Bussmann	Ferraz Shawmut (Gould Shawmut)	SIBA
				A	7P0	10
9P0						
012						
020						
029						
038						
055						
073						
093						
110						
B	146	20	10 x 38 mm	FWC-25A10F	A60Q25-2	60 033 05.25
180						
218						
265						
360						
434						

(1) Internal fuses - provided with the drive.

460V AC Input Drives

Frame	Drive Current Rating Code	Field Amps	Type	Fuse Code FS3 ⁽¹⁾ (See Frame A and B Fuse Designations on page 47 and Frame A Field AC Input Line Fuses Location below and Frame B Field AC Input Line Fuses Location on page 51 for location.)			
				Bussmann	Ferraz Shawmut (Gould Shawmut)	SIBA	
A	4P1	10	6 x 32 mm	FWH-016A6F	E085449	70 125 40.16	
	6P0						
	010						
	014						
	019						
	027						
	035						
	045						
	052						
	073						
	B	167	20	10 x 38 mm	FWC-25A10F	A60Q25-2	60 033 05.25
		207					
		250					
330							
412							

(1) Internal fuses - provided with the drive.

Frame A Field AC Input Line Fuses Location

Bottom View of Drive with Fan



Bottom View of Drive without Fan

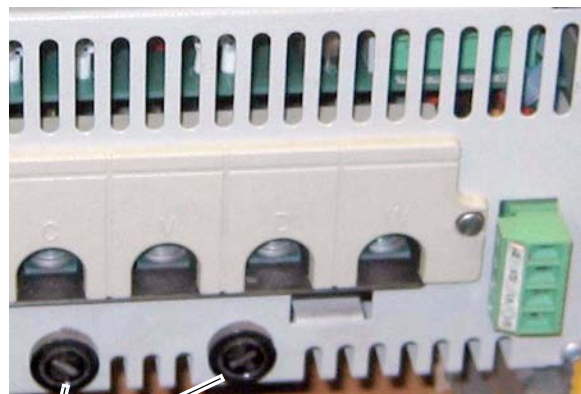

Field circuit fuses

Frame B Field AC Input Line Fuses Location

Top View of Drive



Field circuit fuses

Frame C and D Fuse Designations

All fuses for armature and field circuit protection are internally mounted and provided with frame C and D drives.

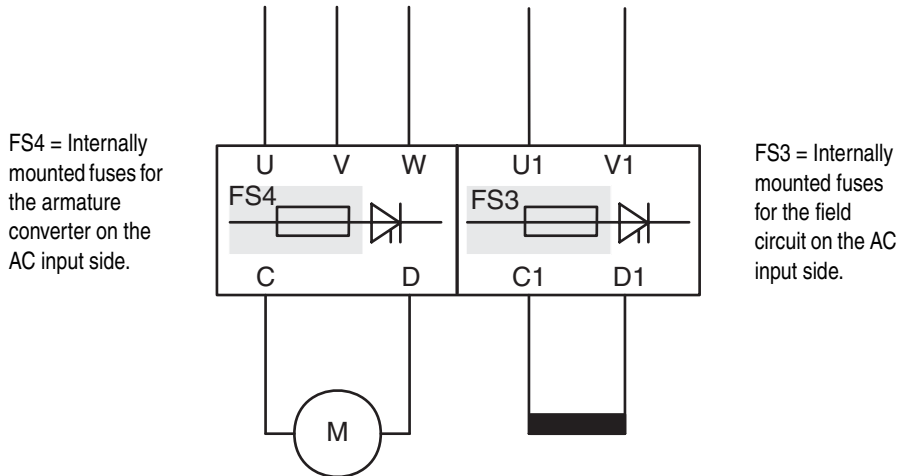

Frame C and D Recommended Field Circuit Fuses

230V AC Input Drives

Frame	Drive Current Rating Code	Field Amps	Type	Fuse Code FS3 (See Frame C and D Fuse Designations on page 51 and Frame C Field Circuit Fuse Location on page 53 and Frame D Field Circuit Fuse Location on page 53 for location.)			
				Qty	Bussmann	Ferraz Shawmut (Gould Shawmut)	SIBA
C	521	20	10 x 38 mm	2	FWC-25A10F	A60Q25-2	6003305.25
	700						
D	875	40	22 x 58 mm		FWP-50A22F	A70QS50-22F	5014006.50
	1K0						

460V AC Input Drives

Frame	Drive Current Rating Code	Field Amps	Type	Fuse Code FS3 (See Frame C and D Fuse Designations on page 51 and Frame C Field Circuit Fuse Location on page 53 and Frame D Field Circuit Fuse Location on page 53 for location.)			
				Qty	Bussmann	Ferraz Shawmut (Gould Shawmut)	SIBA
C	495	20	10 x 38 mm	2	FWC-25A10F	A60Q25-2	6003305.25
	667					A60Q25-8	
D	830	40	22 x 58 mm		FWP-50A22F	A70QS50-22F	5014006.50
	996						
	1K1	70			FWP-100A22F	A70QS100-22F	5014006.100
	1K3						
	1K4						

575V AC Input Drives

Frame	Drive Current Rating Code	Field Amps	Type	Qty	Fuse Code FS3 (See Frame C and D Fuse Designations on page 51 and Frame D Field Circuit Fuse Location on page 53 for location.)		
					Bussmann	Ferraz Shawmut (Gould Shawmut)	SIBA
D	810	40	22 x 58 mm	2	FWP-50A22F	A70QS50-22F	5014006.50
	1K0						
	1K2						
	1K3						
	1K6						

690V AC Input Drives

Frame	Drive Current Rating Code	Field Amps	Type	Qty	Fuse Code FS3 (See Frame C and D Fuse Designations on page 51 and Frame D Field Circuit Fuse Location on page 53 for location.)		
					Bussmann	Ferraz Shawmut (Gould Shawmut)	SIBA
D	678	40	22 x 58 mm	2	FWP-50A22F	A70QS50-22F	5014006.50
	791						
	904						
	1K0						
	1K1	70			FWP-100A22F	A70QS100-22F	5014006.100
	1K2						
	1K4						
	1K5						

Frame C Field Circuit Fuse Location

Field AC input fuses are located on the Control EMI shield, which holds the Control board.

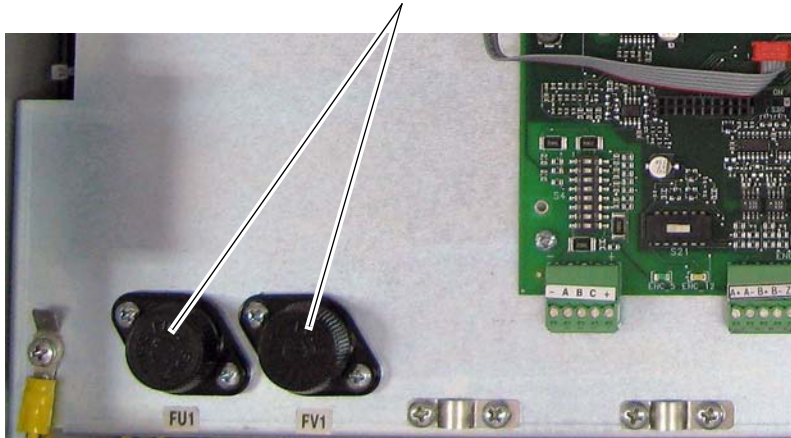

Frame D Field Circuit Fuse Location

Top, left side of drive control panel.

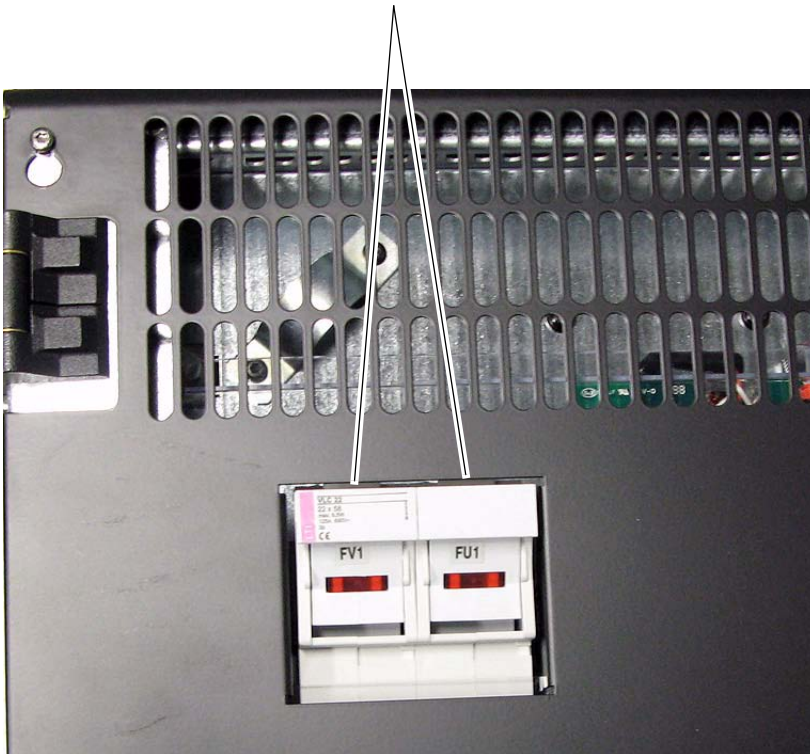

Fuses for Regenerative Frame C and D Drives

Recommended Leg Fuses - 230V AC Input Frame C Drives

Drive Current Rating Code	DC Amps	AC Line Amps	Qty	Fuse Code FS4 (See Frame C and D Fuse Designations on page 51 and Frame C Regenerative Drive - Leg Fuse Location on page 55 for location)		
				Bussmann	Ferraz Shawmut (Gould Shawmut)	SIBA
Square Body - Flush End Contact						
521	521	426	6	170M5464 + switch 170H0069	6,9 URD 32 TTF 800 + switch MS 3-V1-5 BS	20 671 32.800 + switch 28 001 04
700	700	571	6	170M5464 + switch 170H0069	6,9 URD 32 TTF 800 + switch MS 3V 1-5 BS	20 671 32.800 + switch 28 001 04

Recommended Leg Fuses - 230V AC Input Frame D Drives

Drive Current Rating Code	DC Amps	AC Line Amps	Qty	See Fuse Code FS4 (See Frame C and D Fuse Designations on page 51 and Frame D Regenerative Drive - Leg Fuse Location on page 55 for location)		
				Bussmann	Ferraz Shawmut (Gould Shawmut)	SIBA
Square Body - DIN 43653 Stud-Mount						
875	875	715	6	170M6263 + switch 170H0069	Y300263 + switch MS 3V 1-5 UR	20 635 32.900 + switch 28 001 04
1K0	1050	858	6	170M6264 + switch 170H0069	Z300264 + switch MS 3V 1-5 UR	20 635 32.1000 + switch 28 001 04

Recommended Leg Fuses - 460V AC Input Frame C Drives

Drive Current Rating Code	DC Amps	AC Line Amps	Qty	See Fuse Code FS4 (See Frame C and D Fuse Designations on page 51 and Frame C Regenerative Drive - Leg Fuse Location on page 55 for location)		
				Bussmann	Ferraz Shawmut (Gould Shawmut)	SIBA
Square Body - Flush End Contact						
495	495	404.4	6	170M5462 + switch 170H0069	6,9 URD 32 TTF 630 + switch MS 3-V1-5 BS	20 671 32.630 + switch 28 001 04
667	667	544.9	6	170M5464 + switch 170H0069	6,9 URD 32 TTF 800 + switch MS 3-V1-5 BS	20 671 32.800 + switch 28 001 04

Recommended Leg Fuses - 460V AC Input Frame D Drives

Drive Current Rating Code	DC Amps	AC Line Amps	Qty	See Fuse Code FS4 (See Frame C and D Fuse Designations on page 51 and Frame D Regenerative Drive - Leg Fuse Location on page 55 for location)		
				Bussmann	Ferraz Shawmut (Gould Shawmut)	SIBA
Square Body - DIN 43653 Stud-Mount						
830	830	678.1	6	170M6262 + switch 170H0069	X300262 + switch MS 3V 1-5 UR	20 635 32.800 + switch 28 001 04
996	996	813.7	6	170M6264 + switch 170H0069	Z300264 + switch MS 3V 1-5 UR	20 635 32.1000 + switch 28 001 04
1K1	1162	949.4	6	170M6265 + switch 170H0069	A300262 + switch MS 3V 1-5 UR	20 635 32.1100 + switch 28 001 04
1K3	1328	1085.0	6	170M6266 + switch 170H0069	B300266 + switch MS 3V 1-5 UR	20 635 32.1250 + switch 28 001 04
1K4	1494	1220.6	6	170M6267 + switch 170H0069	C300267 + switch MS 3V 1-5 UR	20 635 32.1400 + switch 28 001 04

Recommended Leg Fuses - 575V AC Input Frame D Drives

Drive Current Rating Code	DC Amps	AC Line Amps	Qty	See Fuse Code FS4 (See Frame C and D Fuse Designations on page 51 and Frame D Regenerative Drive - Leg Fuse Location on page 55 for location)		
				Bussmann	Ferraz Shawmut (Gould Shawmut)	SIBA
Square Body - DIN 43653 Stud-Mount						
810	810	661	6	170M6246 + switch 170H0069	J300572 + switch MS 3V 1-5 UR	20 735 32.800 + switch 28 001 04
1K0	1080	881	6	170M6248 + switch 170H0069	L300574 + switch MS 3V 1-5 UR	20 735 32.1000 + switch 28 001 04
1K2	1215	991	12	170M6244 + switch 170H0069	G300570 + switch MS 3V 1-5 UR	20 735 32.630 + switch 28 001 04
1K3	1350	1102	12	170M6245 + switch 170H0069	H300571 + switch MS 3V 1-5 UR	20 735 32.700 + switch 28 001 04
1K6	1688	1377	12	170M6246 + switch 170H0069	J300572 + switch MS 3V 1-5 UR	20 735 32.800 + switch 28 001 04

Recommended Leg Fuses - 690V AC Input Frame D Drives

Drive Current Rating Code	DC Amps	AC Line Amps	Qty	See Fuse Code FS4 (See Frame C and D Fuse Designations on page 51 and Frame D Regenerative Drive - Leg Fuse Location below for location)		
				Bussmann	Ferraz Shawmut (Gould Shawmut)	SIBA
				Square Body - DIN 43653 Stud-Mount		
678	678	553	6	170M6244 + switch 170H0069	G300570 + switch MS 3V 1-5 UR	20 735 32.630 + switch 28 001 04
791	791	645	6	170M6246 + switch 170H0069	J300572 + switch MS 3V 1-5 UR	20 735 32.800 + switch 28 001 04
904	904	738	6	170M6247 + switch 170H0069	K300573 + switch MS 3V 1-5 UR	20 735 32.900 + switch 28 001 04
1K0	1017	830	6	170M6248 + switch 170H0069	L300574 + switch MS 3V 1-5 UR	20 735 32.1000 + switch 28 001 04
1K1	1130	922	12	170M6244 + switch 170H0069	G300570 + switch MS 3V 1-5 UR	20 735 32.630 + switch 28 001 04
1K2	1243	1014	12	170M6244 + switch 170H0069	G300570 + switch MS 3V 1-5 UR	20 735 32.630 + switch 28 001 04
1K4	1413	1153	12	170M6245 + switch 170H0069	H300571 + switch MS 3V 1-5 UR	20 735 32.700 + switch 28 001 04
1K5	1582	1291	12	170M6246 + switch 170H0069	J300572 + switch MS 3V 1-5 UR	20 735 32.800 + switch 28 001 04

Frame C Regenerative Drive - Leg Fuse Location

Note: Drive shown with front covers removed and Control EMI shield lowered.

Leg fuses and switches are located on the bus bars behind the Control EMI shield, which holds the Control board.

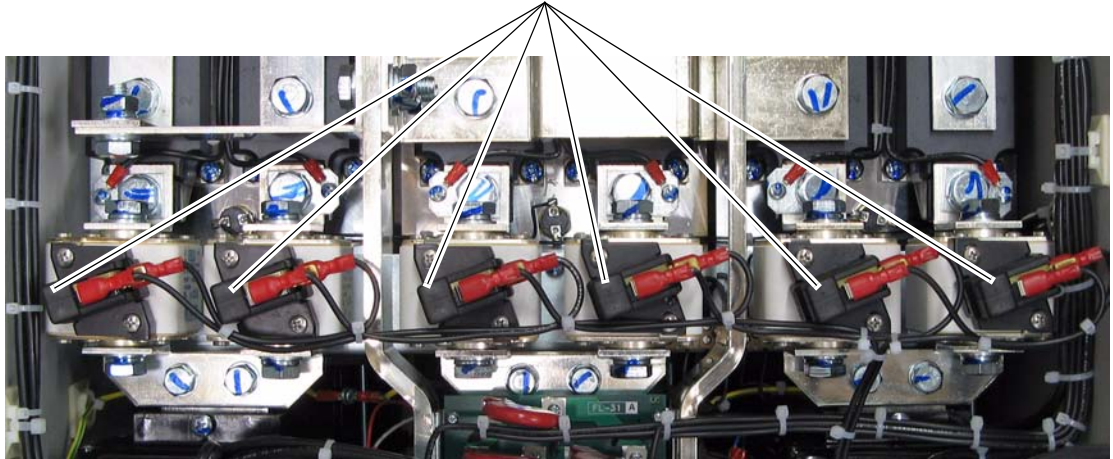

Frame D Regenerative Drive - Leg Fuse Location

Note: Drive shown with Control EMI shield in open position.

Leg fuses and switches are located on the bus bars behind the Control EMI shield, which holds the Control board.



Fuses for Non-Regenerative Frame C and D Drives

Recommended AC Input Line Fuses - 230V AC Input Frame C

Drive Current Rating Code	DC Amps	AC Line Amps	Qty	Fuse Code FS4 (See Frame C and D Fuse Designations on page 51 and Frame C Regenerative Drive - Leg Fuse Location on page 55 for location)		
				Bussmann	Ferraz Shawmut (Gould Shawmut)	SIBA
				Square Body - Flush End Contact		
521	521	426	3	170M5466 + switch 170H0069	6,9 URD 32 TTF 1000 + switch MS 3-V1-5 BS	20 671 32.1000 + switch 28 001 04
700	700	571	3	170M5466 + switch 170H0069	6,9 URD 32 TTF 1000 + switch MS 3V 1-5 BS	20 671 32.1000 + switch 28 001 04

Recommended Leg Fuses - 230V AC Input Frame D Drives

Drive Current Rating Code	DC Amps	AC Line Amps	Qty	Fuse Code FS4 (See Frame C and D Fuse Designations on page 51 for location)		
				Bussmann	Ferraz Shawmut (Gould Shawmut)	SIBA
				Square Body - DIN 43653 Stud-Mount		
875	875	715	6	170M6263 + switch 170H0069	Y300263 + switch MS 3V 1-5 UR	20 635 32.900 + switch 28 001 04
1K0	1050	858	6	170M6264 + switch 170H0069	Z300264 + switch MS 3V 1-5 UR	20 635 32.1000 + switch 28 001 04

Recommended AC Input Line Fuses - 460V AC Input Frame C

Drive Current Rating Code	DC Amps	AC Line Amps	Qty	Fuse Code FS4 (See Frame C and D Fuse Designations on page 51 and Frame C Regenerative Drive - Leg Fuse Location on page 55 for location)		
				Bussmann	Ferraz Shawmut (Gould Shawmut)	SIBA
				Square Body - Flush End Contact		
495	495	404.4	3	170M5464 + switch 170H0069	6,9 URD 32 TTF 800 + switch MS 3-V1-5 BS	20 671 32.800 + switch 28 001 04
667	667	544.9	3	170M5466 + switch 170H0069	6,9 URD 32 TTF 1000 + switch MS 3-V1-5 BS	20 671 32.1000 + switch 28 001 04

Recommended Leg Fuses - 460V AC Input Frame D Drives

Drive Current Rating Code	DC Amps	AC Line Amps	Qty	Fuse Code FS4 (See Frame C and D Fuse Designations on page 51 for location)		
				Bussmann	Ferraz Shawmut (Gould Shawmut)	SIBA
				Square Body - DIN 43653 Stud-Mount		
830	830	678.1	6	170M6262 + switch 170H0069	X300262 + switch MS 3V 1-5 UR	20 635 32.800 + switch 28 001 04
996	996	813.7	6	170M6264 + switch 170H0069	Z300264 + switch MS 3V 1-5 UR	20 635 32.1000 + switch 28 001 04
1K1	1162	949.4	6	170M6265 + switch 170H0069	A300262 + switch MS 3V 1-5 UR	20 635 32.1100 + switch 28 001 04
1K3	1328	1085.0	6	170M6266 + switch 170H0069	B300266 + switch MS 3V 1-5 UR	20 635 32.1250 + switch 28 001 04
1K4	1494	1220.6	6	170M6267 + switch 170H0069	C300267 + switch MS 3V 1-5 UR	20 635 32.1400 + switch 28 001 04

Recommended Leg Fuses - 575V AC Input Frame D Drives

Drive Current Rating Code	DC Amps	AC Line Amps	Qty	Fuse Code FS4 (See Frame C and D Fuse Designations on page 51 for location)		
				Bussmann	Ferraz Shawmut (Gould Shawmut)	SIBA
				Square Body - DIN 43653 Stud-Mount		
810	810	661	6	170M6262 + switch 170H0069	X300262 + switch MS 3V 1-5 UR	20 635 32.800 + switch 28 001 04
1K0	1080	881	6	170M6264 + switch 170H0069	Z300264 + switch MS 3V 1-5 UR	20 635 32.1000 + switch 28 001 04
1K2	1215	991	6	170M6265 + switch 170H0069	A300262 + switch MS 3V 1-5 UR	20 635 32.1100 + switch 28 001 04
1K3	1350	1102	6	170M6266 + switch 170H0069	B300266 + switch MS 3V 1-5 UR	20 635 32.1250 + switch 28 001 04
1K6	1688	1377	12	170M6262 + switch 170H0069	X300262 + switch MS 3V 1-5 UR	20 635 32.800 + switch 28 001 04

Recommended Leg Fuses - 690V AC Input Frame D Drives

Drive Current Rating Code	DC Amps	AC Line Amps	Qty	Fuse Code FS4 (See Frame C and D Fuse Designations on page 51 for location)		
				Bussmann	Ferraz Shawmut (Gould Shawmut)	SIBA
				Square Body - DIN 43653 Stud-Mount		
678	678	553	6	170M6260 + switch 170H0069	V300260 + switch MS 3V 1-5 UR	20 635 32.630 + switch 28 001 04
791	791	645	6	170M6262 + switch 170H0069	X300262 + switch MS 3V 1-5 UR	20 635 32.800 + switch 28 001 04
904	904	738	6	170M6263 + switch 170H0069	Y300263 + switch MS 3V 1-5 UR	20 635 32.900 + switch 28 001 04
1K0	1017	830	6	170M6264 + switch 170H0069	Z300264 + switch MS 3V 1-5 UR	20 635 32.1000 + switch 28 001 04
1K1	1130	922	6	170M6265 + switch 170H0069	A300262 + switch MS 3V 1-5 UR	20 635 32.1100 + switch 28 001 04
1K2	1243	1014	6	170M6266 + switch 170H0069	B300266 + switch MS 3V 1-5 UR	20 635 32.1250 + switch 28 001 04
1K4	1413	1153	6	170M6267 + switch 170H0069	C300267 + switch MS 3V 1-5 UR	20 635 32.1400 + switch 28 001 04
1K5	1582	1291	12	170M6262 + switch 170H0069	X300262 + switch MS 3V 1-5 UR	20 635 32.800 + switch 28 001 04

Frame C Non-Regenerative Drive - AC Input Line Fuse Location

AC Input fuses and switches are located on the bus bars behind the Control EMI shield, which holds the Control board.

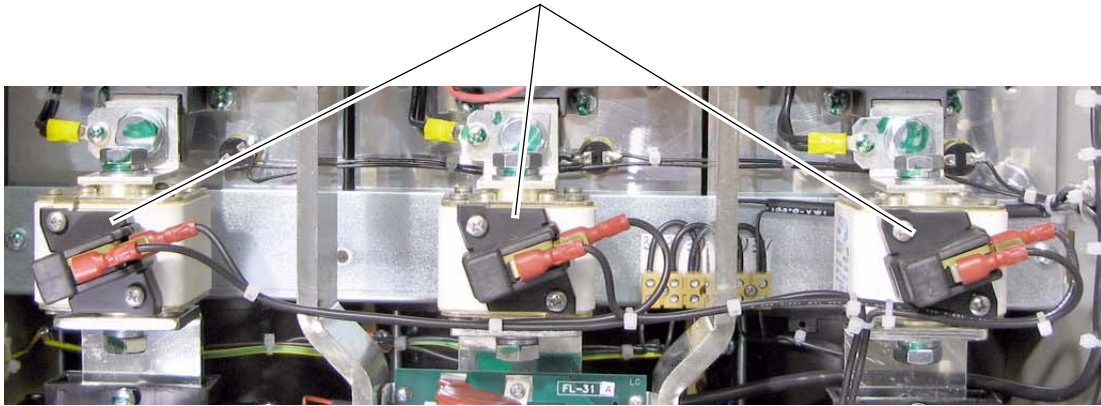

Note: Drive shown with front covers removed and Control EMI shield lowered.

Control Power Circuit Protection Fuses

The following fuses are used to protect the Switching Power Supply circuit.

Important: Verify the circuit board revision prior to ordering and installing fuses.

Frame	Circuit Board ID / Revision	Designation	Fuse (5 x 20 mm)
A	SW1-31 / H & below	F1	1 A, 250V, slow
	SW1-31 / I & above	F1	2.5 A, 250V, slow
B	SW2-32 / H & below	F1	3.15 A, 250V fast
		F2	2.5 A, 250V slow
	SW2-32 / I & above	F1	2.5 A, 250V slow
		F2	
C	SW3-32 / H & below	F1	3.15 A, 250V fast
		F2	2.5 A, 250V slow
	SW3-32 / I & above	F1	2.5 A, 250V slow
		F2	
D	SW1-31 / I & above	F1	2.5 A, 250V, slow

Frame A Switching Power Supply Fuse Location

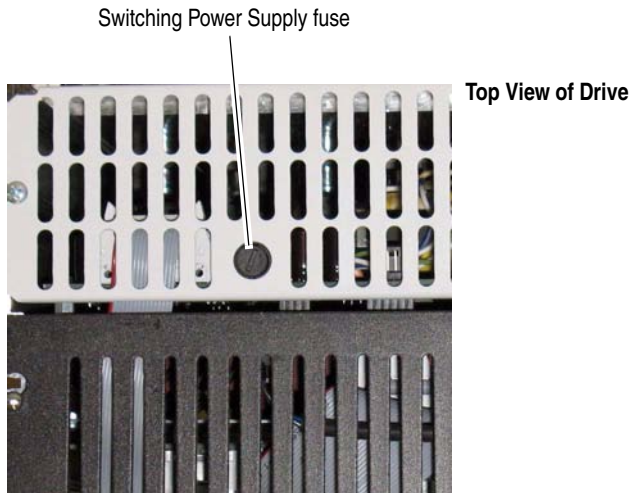

Frame B Switching Power Supply Fuse Location

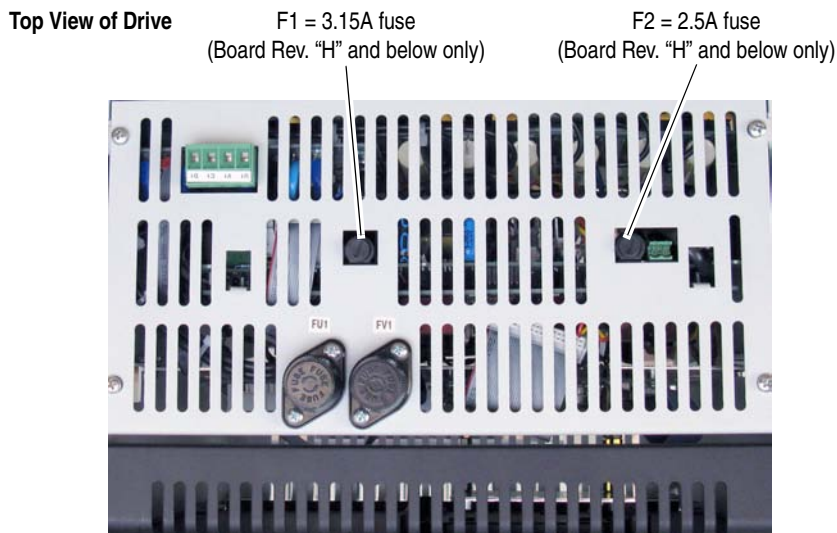

Frame C Switching Power Supply Fuse Location

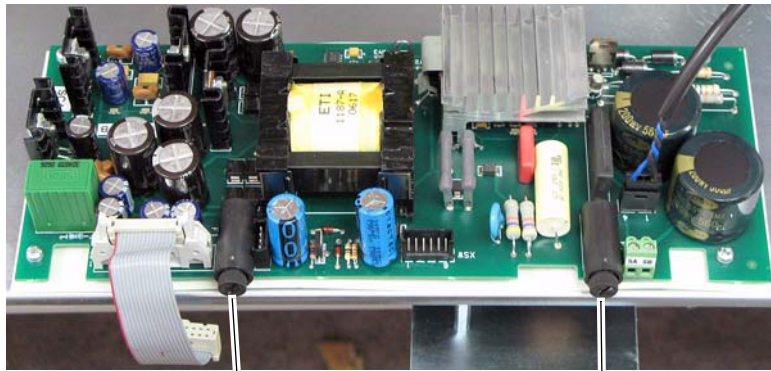

F1 = 3.15A fuse
(Board Rev. "H" and below only)

F2 = 2.5A fuse
(Board Rev. "H" and below only)

Fuses are located on the Switching Power Supply circuit board (SW-2) on the back of the Control EMI shield, which holds the Control board.

Frame D Switching Power Supply Circuit Board Fuse Location

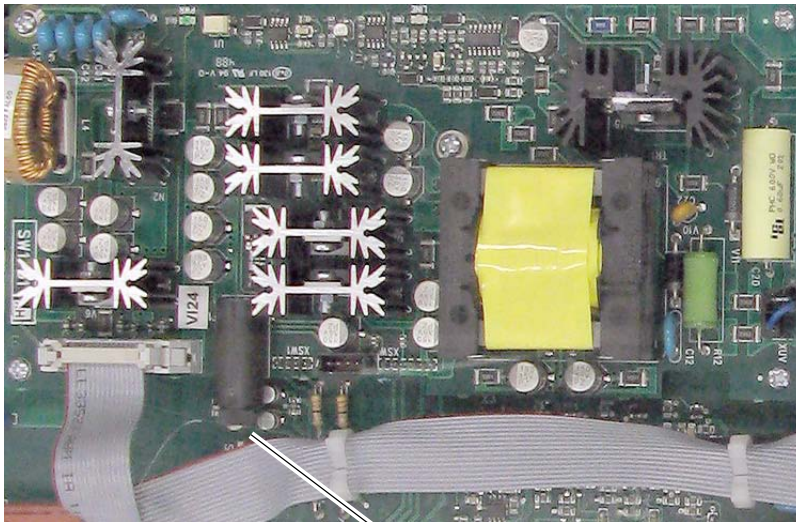

Switching Power Supply fuse holder

The Switching Power Supply circuit board is located on the Control EMI shield.

Mounting

Operating Conditions and Temperatures

PowerFlex DC drives are designed to operate at 0°...50° C (32°... 122° F) surrounding air temperature without derating. The drive must be mounted in a clean, dry location. Contaminants such as oils, corrosive vapors and abrasive debris must be kept out of the enclosure. NEMA/UL Type Open, IP20 enclosures are intended for indoor use primarily to provide a degree of protection against contact with enclosed equipment. These enclosures offer no protection against airborne contaminants.

Minimum Mounting Clearances

Minimum clearance requirements are intended to be from drive to drive. Other objects can occupy this space; however, reduced airflow may cause protection circuits to fault the drive. See Drive Enclosure Minimum Mounting Clearances below. The drive must be mounted in a vertical orientation as shown below and must not be mounted at an angle greater than 30° from vertical. In addition, inlet air temperature must not exceed the product specification.

Drive Enclosure Minimum Mounting Clearances

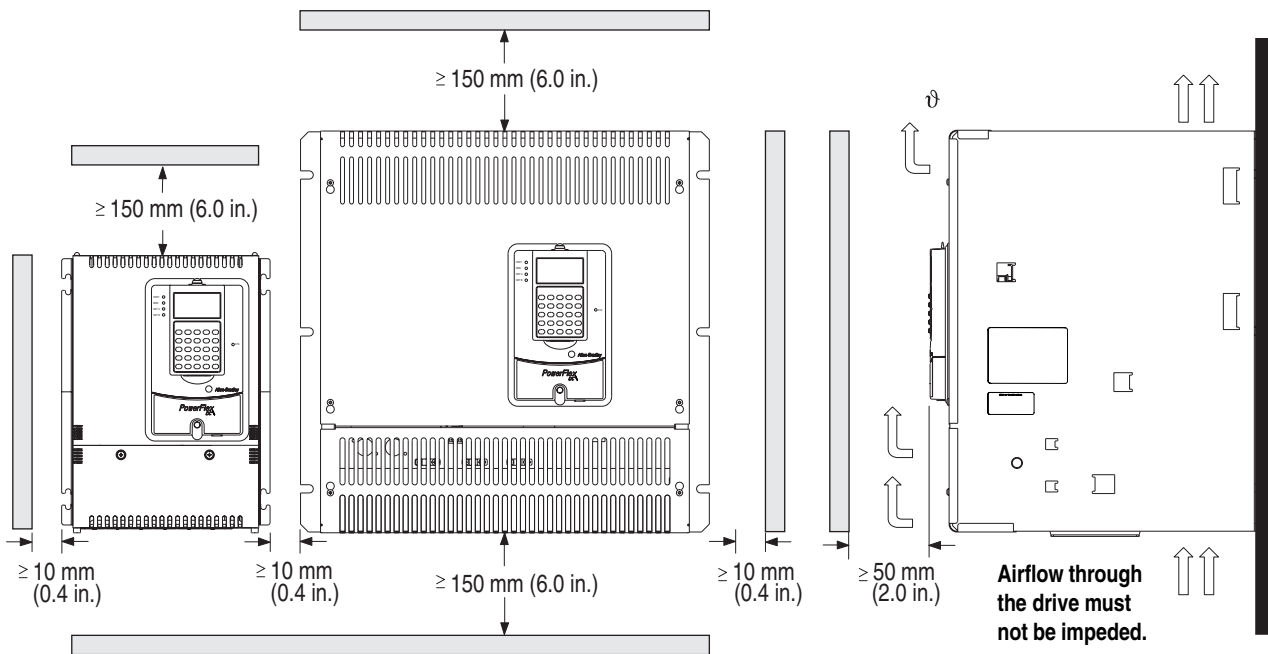

Important: Verify that all mounting screws are properly tightened before and after operation.

Approximate Dimensions

Frame A Dimensions

A	B	C	A1	A2	B1
mm (in.)	mm (in.)	mm (in.)	mm (in.)	mm (in.)	mm (in.)
267 (10.5)	359 (14.0)	287 (11.3)	7 (0.3)	250 (9.8)	275 (10.8)

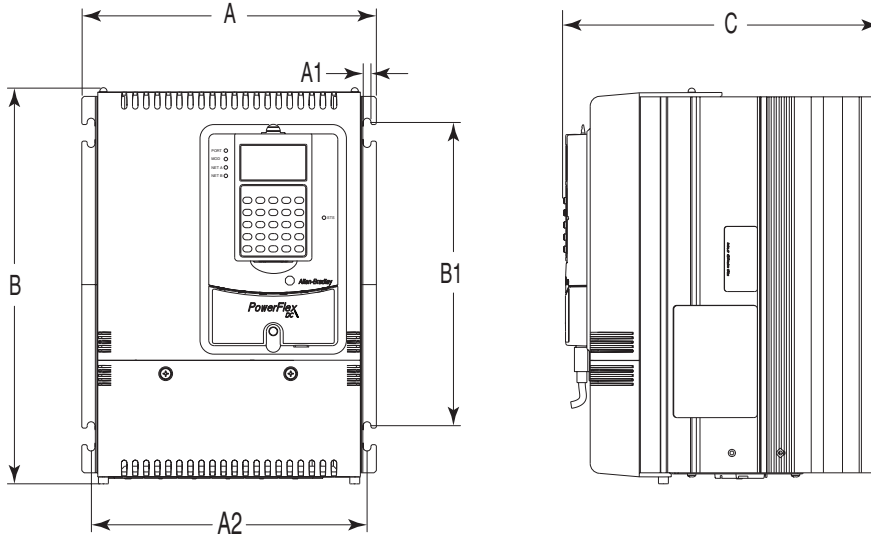

Frame A Weights

Drive w/ND Rating Code		Weight	
		Drive	Drive & Packaging
230V	460V	kg (lbs.)	kg (lbs.)
7P0	4P1	8.4 (19.5)	10.5 (23.1)
9P0	6P0		
012	010		
020	014		
-	019		
029	027		
038	035	8.8 (19.4)	11 (24.3)
055	045		
-	052		
073	073	10.8 (23.8)	13 (28.7)
093	086		
110	-		
-	100		
-	129		

Frame B Dimensions

A	A1	A2	A3	B	B1	C
mm (in.)	mm (in.)	mm (in.)	mm (in.)	mm (in.)	mm (in.)	mm (in.)
311 (12.2)	275 (10.8)	16.5 (0.65)	7 (0.3)	388 (15.3)	375 (14.8)	350 (13.8)

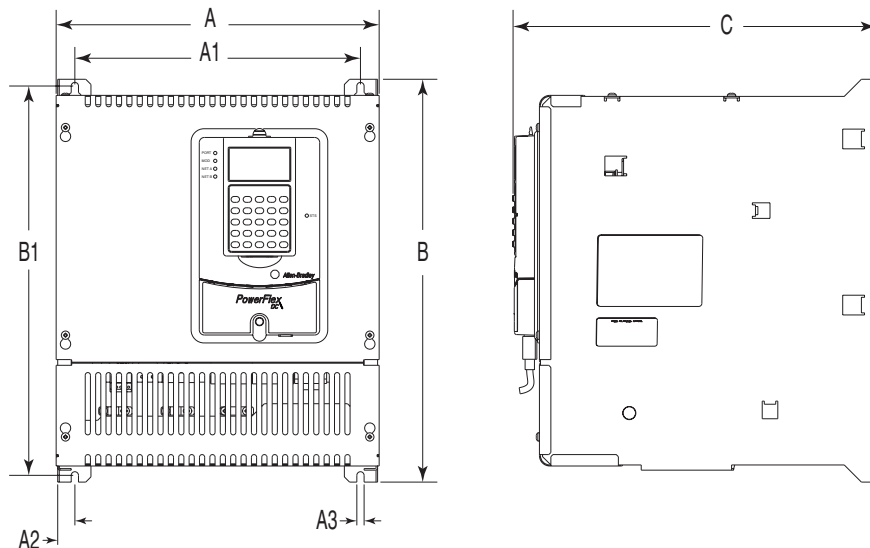

Frame B Weights

Drive w/ND Rating Code		Weight	
		Drive	Drive & Packaging
230V	460V	kg (lbs.)	kg (lbs.)
146	167	25.5 (56.2)	27.5 (60.6)
180	—		
218	207		
265	250	29.5 (65.0)	31.5 (69.4)
360	330	32 (70.5)	34 (75)
434	412		

Frame C Dimensions

A	A1	B	B1	B2	B3	B4	B5	C
mm (in.)	mm (in.)	mm (in.)	mm (in.)	mm (in.)	mm (in.)	mm (in.)	mm (in.)	mm (in.)
521 (20.5)	499 (19.7)	511 (20.1)	400 (15.7)	200 (7.9)	55 (2.2)	56 (2.2)	10.5 (0.4)	416 (16.4)

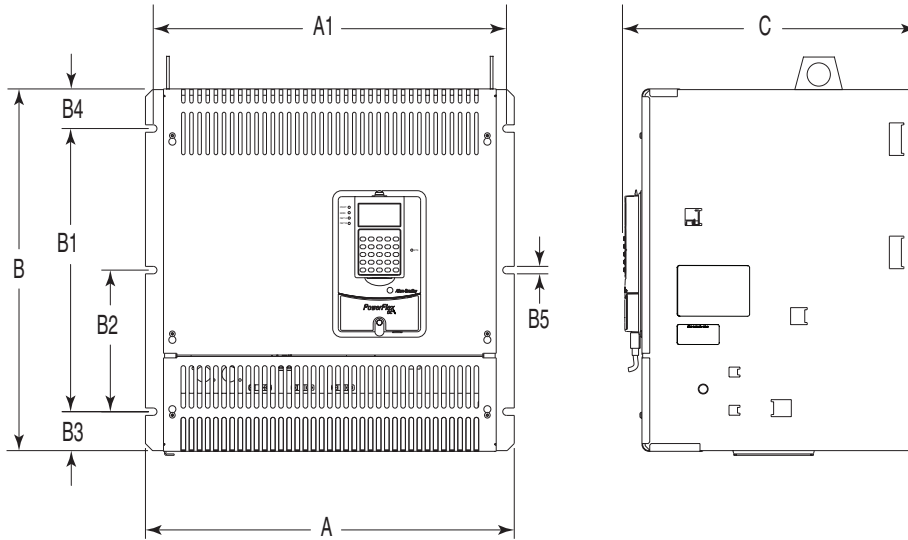

Frame C Weights

Drive w/ND Rating Code	Weight - Regenerative Drives		Weight - Non-regenerative Drives		
	Drive	Drive & Packaging	Drive	Drive & Packaging	
230V	460V	kg (lb)	kg (lb)	kg (lb)	kg (lb)
-	495	61 (134.5)	83 (183.0)	57 (125.7)	79 (174.2)
521	667	65 (143.3)	87 (191.8)	62 (136.7)	84 (185.2)
700	-				

Frame D Dimensions - Front and Side Views

Dimensions are shown in mm and (in.)

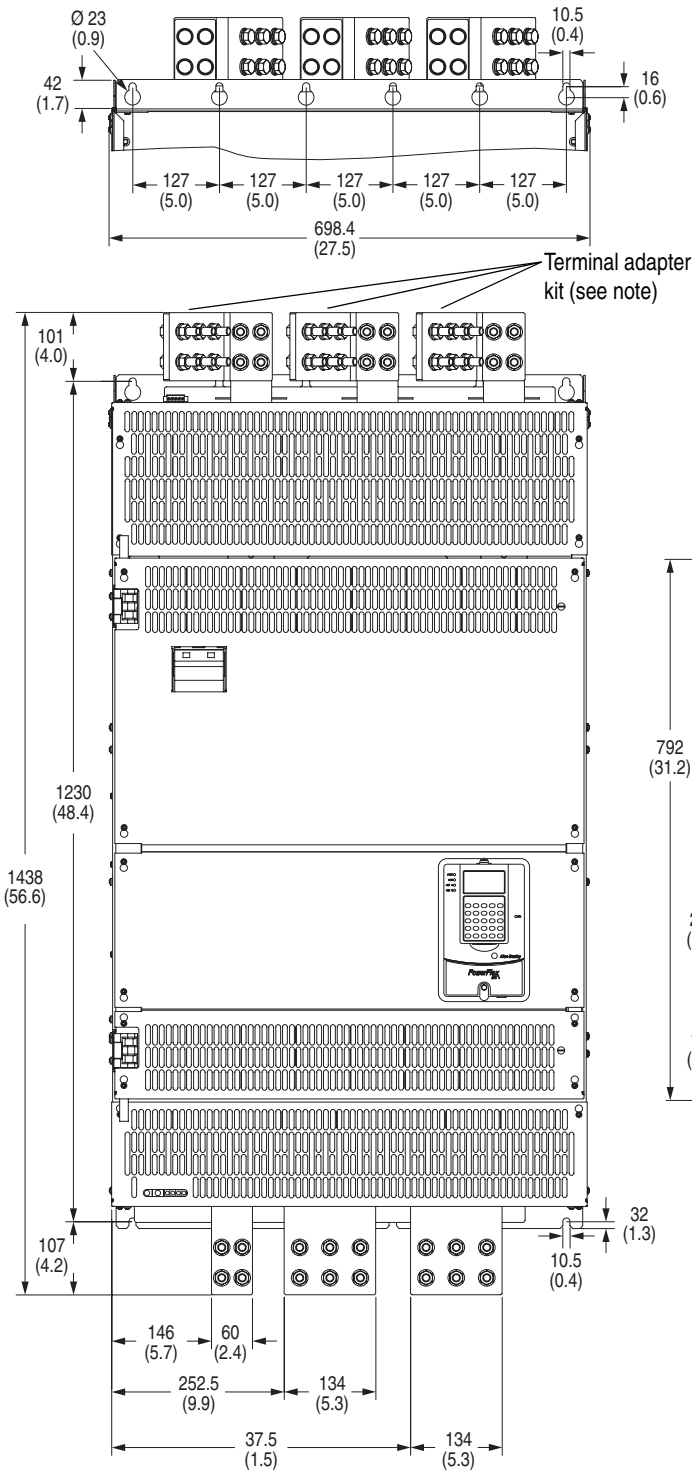

Note: Only certain frame D drives require the use of a terminal adapter kit(s) for terminals U, V, W and C, D. These kits are not included with the drive. Refer to [Frame D Terminal Adapter Kits on page 16](#) for details.

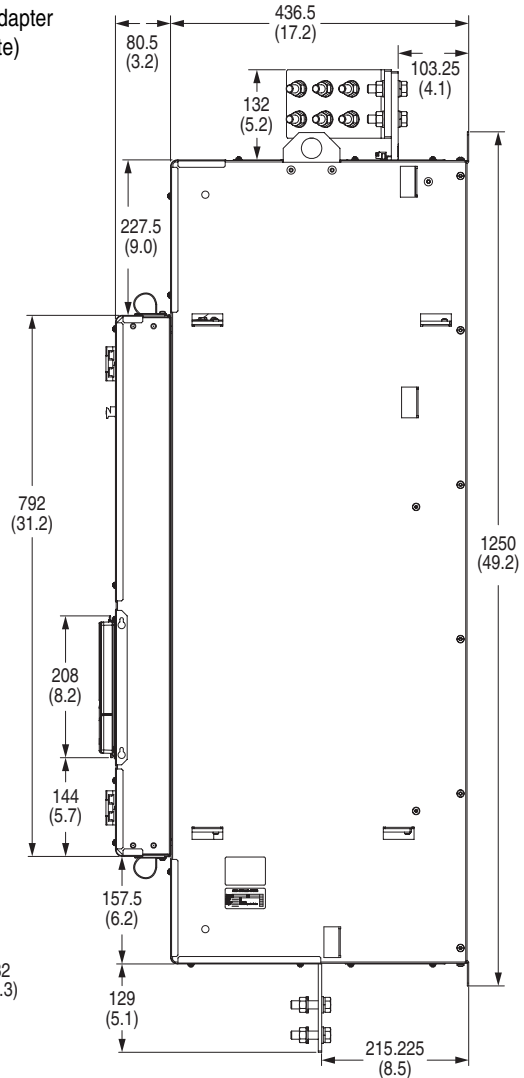

Frame D Dimensions - Top and Bottom Views

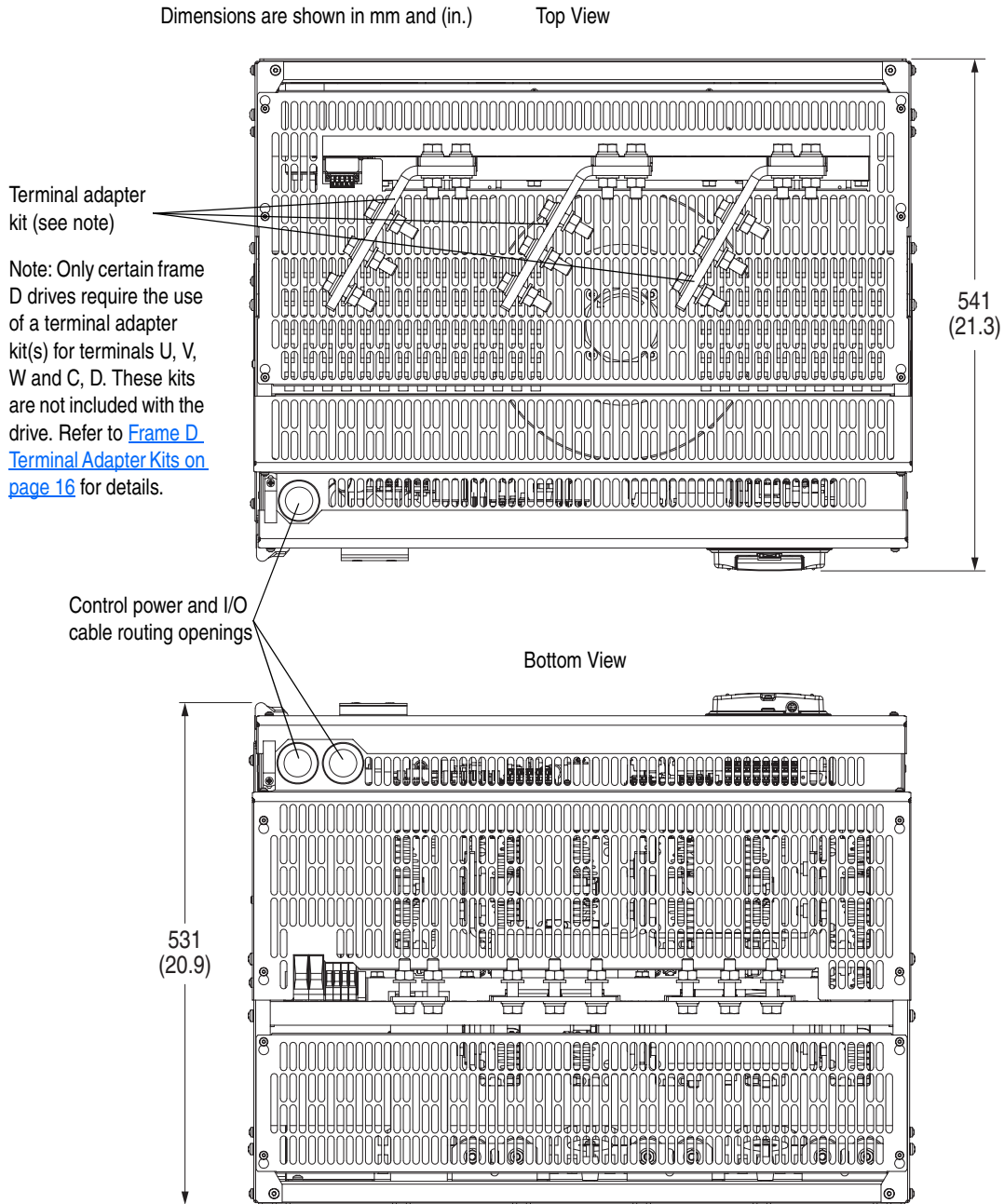

Frame D - 230V AC Input Drive Weights

Drive w/ND Rating Code	Weight - Regenerative Drives		Weight - Non-regenerative Drives	
	Drive kg (lb)	Drive & Packaging kg (lb)	Drive kg (lb)	Drive & Packaging kg (lb)
875	203 (447.5)	281 (619.5)	152 (335.1)	230 (507.1)
1K0				

Frame D - 460V AC Input Drive Weights

Drive w/ND Rating Code	Weight - Regenerative Drives		Weight - Non-regenerative Drives	
	Drive	Drive & Packaging	Drive	Drive & Packaging
	kg (lb)	kg (lb)	kg (lb)	kg (lb)
830	202 (445.3)	280 (617.3)	152 (335.1)	230 (507.1)
996				
1K1	215 (474.0)	293 (646.0)	165 (363.8)	243 (535.7)
1K3				
1K4				

Frame D - 575V AC Input Drive Weights

Drive w/ND Rating Code	Weight - Regenerative Drives		Weight - Non-regenerative Drives	
	Drive	Drive & Packaging	Drive	Drive & Packaging
	kg (lb)	kg (lb)	kg (lb)	kg (lb)
810	198 (436.5)	276 (608.5)	148 (326.3)	226 (498.2)
1K0				
1K2	215 (474.0)	293 (646.0)	165 (363.8)	243 (535.7)
1K3	222 (489.4)	300 (661.4)	172 (379.2)	250 (551.2)
1K6	241 (531.3)	319 (703.3)	191 (421.1)	269 (593.0)

Frame D - 690V AC Input Drive Weights

Drive w/ND Rating Code	Weight - Regenerative Drives		Weight - Non-regenerative Drives	
	Drive	Drive & Packaging	Drive	Drive & Packaging
	kg (lb)	kg (lb)	kg (lb)	kg (lb)
678	198 (436.5)	276 (608.5)	148 (326.3)	226 (498.2)
791				
904	200 (440.9)	278 (612.9)	150 (330.7)	228 (502.7)
1K0	202 (445.3)	280 (617.3)	152 (335.1)	230 (507.1)
1K1	215 (474.0)	293 (646.0)		
1K2			165 (363.8)	243 (535.7)
1K4	241 (531.3)	319 (703.3)	172 (379.2)	250 (551.2)
1K5			191 (421.1)	269 (593.0)

Parameter List

The LCD HIM displays parameters in a **File–Group–Parameter** or **Numbered List** view order. To switch display mode, access the Main Menu, press ALT, then Sel (View) while the cursor is on the Parameter menu selection. In addition, using Par 211 [Param Access Lvl], you have the option to display the most commonly used parameters (Basic Parameter view) or *all* parameters (Advanced Parameter View).

File–Group–Parameter Order

This simplifies programming by grouping parameters that are used for similar functions. The parameters are organized into files. Each file is divided into groups, and each parameter is an element in a group. By default, the LCD HIM displays parameters by File–Group–Parameter view.

Numbered List View

All parameters are in numerical order.

Advanced Parameter View

Parameter 211 [Param Access Lvl] set to option 1 “Advanced”.

Refer to the *PowerFlex Digital DC Drive User Manual*, publication 20P-UM001..., for a list of “Basic” view parameters in File-Group-Parameter order.

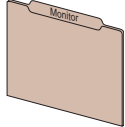
File	Group	Parameters						
	Speed Meters	[Speed Ref A]	44	[Ramp In Pct]	111	[Spd Feedback]	122	
		[Speed Ref A Pct]	47	[Ramp Out]	113	[Spd Feedback Pct]	121	
		[Speed Ref B]	48	[Ramp Out Pct]	114	[Actual Speed]	924	
		[Speed Ref B Pct]	49	[Speed Draw Out]	1018	[Encoder Speed]	420	
		[Speed Ref Out]	385	[Spd Draw Out Pct]	1019	[Tachometer Speed]	1408	
		[Spd Ref Out Pct]	384	[Speed Reg In]	118			
		[Ramp In]	110	[Speed Reg In Pct]	117			
		Current Meters	[Spd Reg Out Pct]	236	[Field Current]	351	[Filt TorqCur Pct]	928
			[Current Reg In]	41	[Fld Current Pct]	234	[Field Ref Pct]	500
	[Arm Current]		200	[Cur Lim Pos Out]	10			
	Drive Data	[Arm Current Pct]	199	[Cur Lim Neg Out]	11			
		[FaultCode]	57	[Output Voltage]	233	[Drive Size]	465	
[AC Line Voltage]		466	[Output Power]	1052	[Elapsed Lifetime]	235		
	[AC Line Freq]	588	[Drive Type]	300	[Software Version]	331		

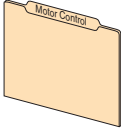
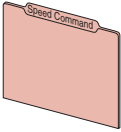
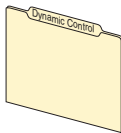
File	Group	Parameters					
	Motor Data	[Max Ref Speed]	45	[Nom Mtr Arm Amps]	179	[Drive Type Sel]	201
		[Max Feedback Spd]	162	[Nom Mtr Fld Amps]	280		
		[Rated Motor Volt]	175	[Drv Fld Brdg Cur]	374		
	Field Config	[Field Reg Enable]	497	[Fld Weaken Ratio]	456	[Fld Reg Ki Base]	98
		[Field Economy En]	499	[Fld Reg Kp]	91	[Set Fld Curve]	919
		[Field Econ Delay]	1407	[Fld Reg Ki]	92	[Reset Fld Curve]	920
		[Field Mode Sel]	469	[Force Min Field]	498	[Fld Const 40 Pct]	916
		[Max Fld Curr Pct]	467	[Out Volt Level]	921	[Fld Const 70 Pct]	917
		[Min Fld Curr Pct]	468	[Fld Reg Kp Base]	97	[Fld Const 90 Pct]	918
	Torq Attributes	[Current Limit]	7	[Torque Reduction]	342	[TrqTpr_Lim2]	753
[Current Lim Pos]		8	[Zero Torque]	353	[TrqTpr_Lim3]	754	
[Current Lim Neg]		9	[TrqTpr_Enable]	750	[TrqTpr_Lim4]	755	
[Torque Ref]		39	[TrqTpr_Lim0]	751	[TrqTpr_Spd]	756	
[Trim Torque]		40	[TrqTpr_Lim1]	752	[Filt Torq Cur]	926	
Speed Feedback	[Fdbk Device Type]	414	[Spd Fdbk Error]	455	[Z Channel Enable]	911	
	[Anlg Tach Gain]	562	[Act Spd Filter]	923	[Z Capture Pos En]	912	
	[Anlg Tach Zero]	563	[Encoder PPR]	169	[Z Captured Pos]	913	
	[Spd Fdbk Control]	457	[Encoder Out Sel]	1021			
	[SpdReg FB Bypass]	458	[Encoder Err Chk]	652			
Autotune	[Autotune Cur Lim]	1048	[Speed Tune Dir]	1029	[I Reg Error]	587	
	[CurrReg Autotune]	452	[Speed Tune Kp]	1032	[Inertia C Filter]	1012	
	[Arm Resistance]	453	[Speed Tune Ki]	1033	[Torque Const]	1013	
	[Arm Inductance]	454	[Spd Tune Inertia]	1030	[Inertia]	1014	
	[Spd Reg Autotune]	1027	[SpdTune Friction]	1031	[Friction]	1015	
Test Generator	[TstGen Output]	58	[TstGen Amplitude]	60	[TstGen Offset]	61	
	[TstGen Frequency]	59					
	Limits	[Minimum Speed]	1	[Min Speed Rev]	6	[Max Speed Fwd]	3
		[Min Speed Fwd]	5	[Maximum Speed]	2	[Max Speed Rev]	4
	Discrete Speeds	[Jog Speed]	266	[Preset Speed 3]	156	[Preset Speed 7]	160
		[Jog Off Delay]	1409	[Preset Speed 4]	157	[TB Manual Ref]	267
		[Preset Speed 1]	154	[Preset Speed 5]	158		
		[Preset Speed 2]	155	[Preset Speed 6]	159		
	Speed References	[Trim Ramp]	42	[Trim Speed]	43	[Speed Ratio]	1017
		[Trim Ramp Pct]	378	[Trim Speed Pct]	379		
	Speed Regulator	[Speed Reg En]	242	[Speed Thresh Neg]	102	[Flying Start En]	388
		[Arm Volt Kp]	493	[Threshold Delay]	103	[Spd Fdbk Filter]	444
[Arm Volt Ki]		494	[At Speed Error]	104	[Spd Up Gain Pct]	445	
[Spd Reg Kp]		87	[At Speed Delay]	105	[Speed Up Base]	446	
[Spd Reg Ki]		88	[Ref Zero Level]	106	[Speed Up Filter]	447	
[Arm Volt Kp Base]		495	[Speed Zero Level]	107	[SpdReg Kp Bypass]	459	
[Arm Volt Ki Base]		496	[Speed Zero Delay]	108	[SpdReg Ki Bypass]	460	
[Spd Reg Kp Base]		93	[Spd Zero I En]	123	[SpdFuncSelect]	1016	
[Spd Reg Ki Base]		94	[Spd Ref Zero En]	124	[InertiaCompAct]	1191	
[Spd Reg Kp Outpt]		99	[Spd Zero P En]	125	[InertiaCompVar]	1192	
[Spd Reg Ki Outpt]		100	[Spd Zero P Gain]	126			
[Speed Thresh Pos]		101	[Lock Speed Integ]	348			
		Ramp Rates	[Speed Ramp En]	245	[MOP Decel Time]	30	[Ramp Delay]
	[Ramp Type Select]		18	[Jog Ramp Time]	1410	[Zero Ramp Output]	344
	[Accel Time 1]		660	[S Curve Time]	19	[Zero Ramp Input]	345
	[Decel Time 1]		662	[S Curve Accel 1]	665	[Freeze Ramp]	373
	[Accel Time 2]		24	[S Curve Decel 1]	666	[Acc Dec Filter]	1212
	[Decel Time 2]		32	[S Curve Accel 2]	667		
	[MOP Accel Time]		22	[S Curve Decel 2]	668		
	Load Limits	[Enable Droop]	699	[Droop Limit]	700	[Torq Limit Type]	715
		[Droop Percent]	696	[Load Comp]	698		
		[Droop Filter]	697	[Torq Red CurLim]	13		
Stop Modes	[Fast Stop Time]	38	[Closing Speed]	1262	[Ramp In Zero En]	1265	
	[Spd 0 Trip Delay]	627	[Opening Delay]	1263	[Actuator Delay]	1266	
Restart Modes	[Start At Powerup]	1344	[Powerup Delay]	1345			
Adaptv Regulator	[Adaptive Spd En]	181	[Adaptive Joint 1]	186	[Adaptive I Gain2]	191	
	[Adaptive Reg Typ]	182	[Adaptive Joint 2]	187	[Adaptive P Gain3]	192	
	[Adaptive Ref]	183	[Adaptive P Gain1]	188	[Adaptive I Gain3]	193	
	[Adaptive Spd 1]	184	[Adaptive I Gain1]	189			
	[Adaptive Spd 2]	185	[Adaptive P Gain2]	190			

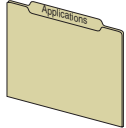
File	Group	Parameters					
Applications 	PI Control	[Enable PI]	769	[PI Central v1]	776	[PI Central vs1]	781
		[PI Steady Thrsh]	695	[PI Central v2]	777	[PI integr freeze]	783
		[PI Integral Gain]	764	[PI Central v3]	778	[PI Upper Limit]	784
		[PI Prop Gain PID]	765	[PI Central v sel]	779	[PI Lower Limit]	785
		[PI Output]	771	[PI Central vs0]	780	[PI Init Prop Gn]	793
	PD Control	[Enable PD]	770	[PD Deriv Filter]	767	[PD Deriv Gain 2]	789
		[PD Output PID]	421	[PD Prop Gain 1]	768	[PD Prop Gain 3]	790
		[PD Deriv Gain 1]	766	[PD Prop Gain 2]	788	[PD Deriv Gain 3]	791
	PID Control	[Enable PID]	1258	[PID Setpoint 0]	760	[PID Target]	782
		[Real FF PID]	418	[PID Setpoint 1]	761	[PID Source]	786
[PID Steady Delay]		731	[PID Setpoint Sel]	762	[PID Source Gain]	787	
[PI Init Intgl Gn]		734	[PID Feedback]	763	[PID Accel Time]	1046	
[PID Clamp]		757	[PID Output Sign]	772	[PID Decel Time]	1047	
[Feed Fwd PID]		758	[PID Output Scale]	773	[PID Error Gain]	1254	
[PID Error]		759	[PID Output]	774			
Scale Blocks	[Scale1 Input]	484	[Scale3 Input]	1218	[Scale5 Input]	1236	
	[Scale1 Output]	485	[Scale3 Output]	1219	[Scale5 Output]	1237	
	[Scale1 Mul]	486	[Scale3 Mul]	1220	[Scale5 Mul]	1238	
	[Scale1 Div]	487	[Scale3 Div]	1221	[Scale5 Div]	1239	
	[Scale1 In Max]	488	[Scale3 In Max]	1222	[Scale5 In Max]	1240	
	[Scale1 In Min]	489	[Scale3 In Min]	1223	[Scale5 In Min]	1241	
	[Scale1 In Off]	490	[Scale3 In Off]	1224	[Scale5 In Off]	1242	
	[Scale1 Out Off]	491	[Scale3 Out Off]	1225	[Scale5 Out Off]	1243	
	[Scale1 In Abs]	492	[Scale3 In Abs]	1226	[Scale5 In Abs]	1244	
	[Scale2 Input]	553	[Scale4 Input]	1227	[Scale6 Input]	1245	
	[Scale2 Output]	554	[Scale4 Output]	1228	[Scale6 Output]	1246	
	[Scale2 Mul]	555	[Scale4 Mul]	1229	[Scale6 Mul]	1247	
	[Scale2 Div]	556	[Scale4 Div]	1230	[Scale6 Div]	1248	
	[Scale2 In Max]	557	[Scale4 In Max]	1231	[Scale6 In Max]	1249	
	[Scale2 In Min]	558	[Scale4 In Min]	1232	[Scale6 In Min]	1250	
	[Scale2 In Off]	559	[Scale4 In Off]	1233	[Scale6 In Off]	1251	
	[Scale2 Out Off]	560	[Scale4 Out Off]	1234	[Scale6 Out Off]	1252	
	[Scale2 In Abs]	561	[Scale4 In Abs]	1235	[Scale6 In Abs]	1253	
	Diameter Calc	[Diameter Calc]	794	[Line Spd Thrsh]	1155	[Diam Preset 0]	1164
		[DncrPosSpd]	795	[Line Spd Gain]	1156	[Diam Preset 1]	1165
[Max Deviation]		796	[Diameter Reset]	1157	[Diam Preset 2]	1166	
[Gear Box Ratio]		797	[Diam Threshold]	1158	[Diam Preset 3]	1167	
[Dancer Constant]		798	[Diameter Reached]	1159	[Diam Preset Sel]	1168	
[Minimum Diameter]		799	[Line Speed Pct]	1160	[Diam Inc Dec En]	1205	
[Diameter Calc St]		800	[Diam Calc Dis]	1161	[Diam init filter]	1206	
[Max Diameter]		1153	[Diameter Filter]	1162	[Diam stdy delay]	1207	
[Roll Diameter]		1154	[Base Omega]	1163			
Winder Functions	[Variable J Comp]	1171	[Line FastStp Pct]	1186	[Torque Winder En]	1209	
	[Constant J Comp]	1172	[Winder Type]	1187	[W Target]	1210	
	[Materl Width Pct]	1173	[Torq Current Pct]	1193	[Actual Comp]	1213	
	[Static Friction]	1174	[Act Ten Ref Pct]	1194	[Closed Loop En]	1214	
	[Dynamic Friction]	1175	[Speed Match]	1195	[Speed Demand En]	1215	
	[Taper Enable]	1176	[Spd Match Acc]	1196	[Spd match torque]	1216	
	[Initial Diameter]	1177	[Spd Match Dec]	1197	[W Reference]	1217	
	[Final Diameter]	1178	[Offs Accel Time]	1198	[Jog TW Speed]	1255	
	[Tension Reduct]	1179	[W Offset]	1199	[Jog TW Enable]	1256	
	[Tension Ref]	1180	[Spd Match Gain]	1200	[Ref Spd Source]	1284	
	[Tension Scale]	1181	[Winder Side]	1201	[Ref Speed Gain]	1285	
	[Time AccDec Min]	1182	[W Gain]	1202	[Ref Line Speed]	1286	
	[Int Acc Calc En]	1183	[Spd Match Compl]	1203	[Static F Zero]	1287	
	[Line Accel Pct]	1184	[Line Spd Source]	1204			
	[Line Decel Pct]	1185	[Close Loop Comp]	1208			

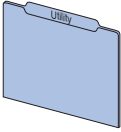
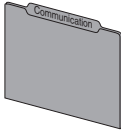
File	Group	Parameters					
	Reference Config	[Direction Mode]	1322	[Man Ref Preload]	210	[MOP Select]	1375
		[Save HIM Ref]	209	[Save MOP Ref]	249		
	Drive Memory	[Param Access Lvl]	211	[Reset Defaults]	258		
	Diagnostics	[Drive Status 1]	381	[Torque Positive]	346	[Accel Status]	1188
		[Drive Status 2]	382	[Torque Negative]	347	[Decel Status]	1189
		[Last Stop Source]	1402	[MOP Inc Active]	396	[Fast Stop Status]	1190
		[Start Inhibits]	1403	[MOP Dec Active]	397	[TestPoint Sel]	1381
		[Drive Logic Rslt]	1328	[Spd Select 0]	400	[TestPoint Data]	1382
		[At Speed]	394	[Spd Select 1]	401	[TaskLoad 32 ms]	1383
		[At Zero Speed]	395	[Spd Select 2]	402	[TaskLoad 1 ms]	1384
		[CurrLimit Active]	349	[Ramp Select 0]	403	[TaskLoad 2 ms]	1385
		[Spd Limit Active]	372	[Ramp Select 1]	404	[TaskLoad 8 ms]	1386
		[Speed Threshold]	393	[Encoder State]	651		
	Faults	[Clear Fault Que]	263	[Fault 2 Code]	1352	[Fault 2 Time]	1362
		[Fault Clear]	1347	[Fault 3 Code]	1353	[Fault 3 Time]	1363
		[Fault Clr Mode]	1348	[Fault 4 Code]	1354	[Fault 4 Time]	1364
		[Status1 at Fault]	1349	[Fault 5 Code]	1355	[Fault 5 Time]	1365
		[Status2 at Fault]	1350	[Fault 6 Code]	1356	[Fault 6 Time]	1366
		[Fault Arm Amps]	1371	[Fault 7 Code]	1357	[Fault 7 Time]	1367
		[Fault Speed]	1372	[Fault 8 Code]	1358	[Fault 8 Time]	1368
		[Fault Field Amps]	1373	[Fault 9 Code]	1359	[Fault 9 Time]	1369
		[Fault Voltage]	1374	[Fault 10 Code]	1360	[Fault 10 Time]	1370
		[Fault 1 Code]	1351	[Fault 1 Time]	1361		
	Alarms	[Drive Alarm 1]	1380	[OverTemp Flt Cfg]	365	[UnderVolt Thresh]	481
		[OverVolt Flt Cfg]	203	[FldLoss Flt Cfg]	473	[OverCurrent Thr]	584
		[Aux Inp Flt Cfg]	354	[Spd Loss Flt Cfg]	478		
	User Defined	[UsrDsplyMult0]	50	[UserDefined14]	517	[UsrDefBitWrdA15]	535
[UsrDsplyDiv0]		51	[UserDefined15]	518	[UsrDefBitWrdB]	536	
[UsrValMult1]		53	[UsrDefBitWrdA]	519	[UsrDefBitWrdB0]	537	
[UsrValDiv1]		54	[UsrDefBitWrdA0]	520	[UsrDefBitWrdB1]	538	
[UserDefined0]		503	[UsrDefBitWrdA1]	521	[UsrDefBitWrdB2]	539	
[UserDefined1]		504	[UsrDefBitWrdA2]	522	[UsrDefBitWrdB3]	540	
[UserDefined2]		505	[UsrDefBitWrdA3]	523	[UsrDefBitWrdB4]	541	
[UserDefined3]		506	[UsrDefBitWrdA4]	524	[UsrDefBitWrdB5]	542	
[UserDefined4]		507	[UsrDefBitWrdA5]	525	[UsrDefBitWrdB6]	543	
[UserDefined5]		508	[UsrDefBitWrdA6]	526	[UsrDefBitWrdB7]	544	
[UserDefined6]		509	[UsrDefBitWrdA7]	527	[UsrDefBitWrdB8]	545	
[UserDefined7]		510	[UsrDefBitWrdA8]	528	[UsrDefBitWrdB9]	546	
[UserDefined8]		511	[UsrDefBitWrdA9]	529	[UsrDefBitWrdB10]	547	
[UserDefined9]		512	[UsrDefBitWrdA10]	530	[UsrDefBitWrdB11]	548	
[UserDefined10]	513	[UsrDefBitWrdA11]	531	[UsrDefBitWrdB12]	549		
[UserDefined11]	514	[UsrDefBitWrdA12]	532	[UsrDefBitWrdB13]	550		
[UserDefined12]	515	[UsrDefBitWrdA13]	533	[UsrDefBitWrdB14]	551		
[UserDefined13]	516	[UsrDefBitWrdA14]	534	[UsrDefBitWrdB15]	552		
	Comm Control	[DPI Baud Rate]	589	[DPI Fdbk Select]	1321	[DPI Port Value]	1343
		[DPI Port Sel]	590				
	Masks & Owners	[Logic Mask]	591	[MOP Mask]	598	[Reference Owner]	604
		[Start Mask]	592	[Local Mask]	599	[Accel Owner]	605
		[Jog Mask]	593	[Decel Mask]	631	[Fault Clr Owner]	606
		[Direction Mask]	594	[Stop Owner]	600	[MOP Owner]	607
		[Reference Mask]	595	[Start Owner]	601	[Local Owner]	608
		[Accel Mask]	596	[Jog Owner]	602	[Decel Owner]	609
		[Fault Clr Mask]	597	[Direction Owner]	603		
	Datalinks	[Data In A1]	610	[Data In D1]	616	[Data Out C1]	622
		[Data In A2]	611	[Data In D2]	617	[Data Out C1]	623
		[Data In B1]	612	[Data Out A1]	618	[Data Out D1]	624
		[Data In B2]	613	[Data Out A2]	619	[Data Out D2]	625
		[Data In C1]	614	[Data Out B1]	620	[Data In Val Sel]	1319
		[Data In C2]	615	[Data Out B2]	621	[Data In SelData]	1320
	Security	[Logic Mask]	591	[Write Mask Act]	1377	[Port Mask Act]	1379
		[Logic Mask Act]	1376	[Write Mask Cfg]	1378		

PowerFlex DC Configured Drives



Overview

The PowerFlex DC Configured Drives allow users to create drive packages based on their specific needs. This program enhances stand-alone drive functionality through additional control, power and packaging options, which are ideal for Original Equipment Manufacturers (OEM) and end users with special installation needs. This program consists of:

- Standard Configured Drives
- Engineer To Order Configured Drives

Standard Configured Drives

The Standard Configured Drives Program allows users to create drive packages based on their specific needs. A complete drive package may be specified by assembling a single catalog number string that includes a base drive and all required options. Packaging is available for 230 and 460V AC requirements in IP20, NEMA/UL Type 1 MCC style enclosures or rigid-panel mounted for installation in an existing enclosure. The program consists of a fully defined catalog string identified within this publication. Focused on higher volume, repeat business, the standard designs provide consistent manufacturing and minimizes customer resources by reducing engineering, manufacturing and installation time. Typical delivery is 6...8 weeks from order entry and can be ordered through the order entry system.

Engineer To Order Configured Drives (ETO)

The Engineer To Order Configured Drives Program offers users the ability to create drive packages beyond the Standard Configured Drives offering. Options may or may not be defined within this publication. Products can be ordered by contacting your Global Drives Systems representative at the central office location or one of the Local Drive Solution Centers. Our engineering experts will assist in defining the specific requirements of your application.

The Standard Configured Drive designs may be modified to meet the design criteria or a complete custom package can be designed for any application. The typical lead time of an ETO order is 8...12 weeks based on the lead time and availability of unique components of the design.

Benefits

- Simplified installation and start-up by use of common options assembled at the factory.
- Drive functionality exceeds options offered with a standard drive.
- Multiple packaging options specific to customer needs.
- Pre-engineered options for easy order entry, consistent manufacturing, high quality and reduced delivery time.
- Selectable configurations to meet application requirements.

Features

- Standard PowerFlex DC Digital drives and drive-related options.
- 6 pulse and 12 pulse.
- Enclosure options: IP20 MCC, IP42 Filter, IP00 (mounted on a panel), either conformal coated circuit boards or without.
- Pre-engineered options.
- Custom/engineered solutions.
- UL panel recognition from the factory for pre-engineered options.

Factory Installed Options

Enclosure Options

The PowerFlex Configured DC drives can be ordered in a IP20, NEMA/UL Type 1 MCC style enclosure or a IP43, NEMA/UL Type 1 with Fan & Filter MCC style enclosure. For both of these enclosures the drive, incoming disconnect and any specified operator devices will be mounted and wired in the cabinet or on the door as required. If a cabinet mounted input line reactor is specified, it will be mounted in the cabinet for drives ratings of 200 Hp or less. The drive may also be ordered on a rigid panel for installation in a users existing cabinet. For these designs the drive and all panel mounted parts will be mounted and wired. The incoming disconnect, operator devices and input line reactor will be shipped loose for customer mounting and wiring per local codes.

All MCC cabinets are 2286 mm H x 635 mm D (90 in. H x 25 in. D) with the width determined by the size of the drive and the options requested. The standard width enclosures are 508, 635, 889 mm (20, 25 and 35 in.) wide. The rigid panel mount designs are shipped on a 1981 mm H x 508 mm W or 813 mm W (78 in. H x 20 in. W or 32 in. W) panel to fit a standard 610 mm W X 914 mm W (24 in. W or 36 in. W) enclosure.

Human Interface Module (HIM) Options

The PowerFlex Configured DC drives can be ordered with a variety of HIM modules to meet the needs of each drive. The HIM's are installed on the door of the enclosures or shipped loose on the Open Panel designs. All designs have the door mounted bezel and interconnect cable to the drive. HIM's can be installed or updated in the field.



No HIM (Blank Plate)
Catalog Code: 0



LCD Display, Full
Numeric Keypad
Catalog Code: C



LCD Display,
Programmer Only
Catalog Code: E

I/O Options

The PowerFlex Configured DC drive has built-in configurable digital and analog I/O. The digital I/O is 24V DC and the analog I/O can be configured for voltage or current operation. Additional 24V DC and analog I/O can be added or an I/O conversion card can be added to accommodate 115V AC digital I/O.

I/O Options	
Control	Code
I/O Expansion Card (4 Additional 24V dc Digital Inputs & Outputs, 2 Analog Outputs)	A
115V ac Conversion Card (8 Digital Inputs & Outputs)	B
8 - 24V - dc Digital Inputs & Outputs, 3 Analog Outputs and 2 Analog Inputs	N

Communication Options

The PowerFlex Configured DC drives are fully compatible with Allen-Bradley drive's wide variety of DPI communication adapters, offering the following options.

Description	Catalog No.
ControlNet™ Communication Adapter (Coax)	C
DeviceNet™ Communication Adapter	D
EtherNet/IP™ Communication Adapter	E
Interbus™ Communication Adapter	I
LonWorks™ Communication Adapter	L
PROFIBUS™ DP Communication Adapter	P
ControlNet™ Communication Adapter (Fiber)	Q
Remote I/O Communication Adapter	R
None	N

Cabinet Options

The Configured Drive enclosure can be equipped with a variety of standard user option. These options are predefined as described below. Other options can be ordered through the ETO program.

Description	Catalog No.
None	N
Start and Stop PB's	1
Local/Remote SS	2
E-Stop PB	3
Jog	4
Blower Motor Starter	5
Options 1 & 2	A
Options 1 & 3	B
Options 1 & 4	C
Options 1 - 3	D
Options 1 - 4	E
Options 1 - 5	F
Options A & 4	G
Options A & 5	H
Options B & 4	J
Options B & 5	K

Certifications

The PowerFlex DC Drive is a UL/cUL certified product. The Configured Drive enclosure can also be built to UL/cUL certification and to CSA certification.

Description	Code
None (Drive unit is UL/cUL)	N
UL/cUL	1
CSA Inspection & certification	2

Please contact your local distributor or sales office for product availability. Configured Drives offers Quick Ship and Pre-Engineered Programs.

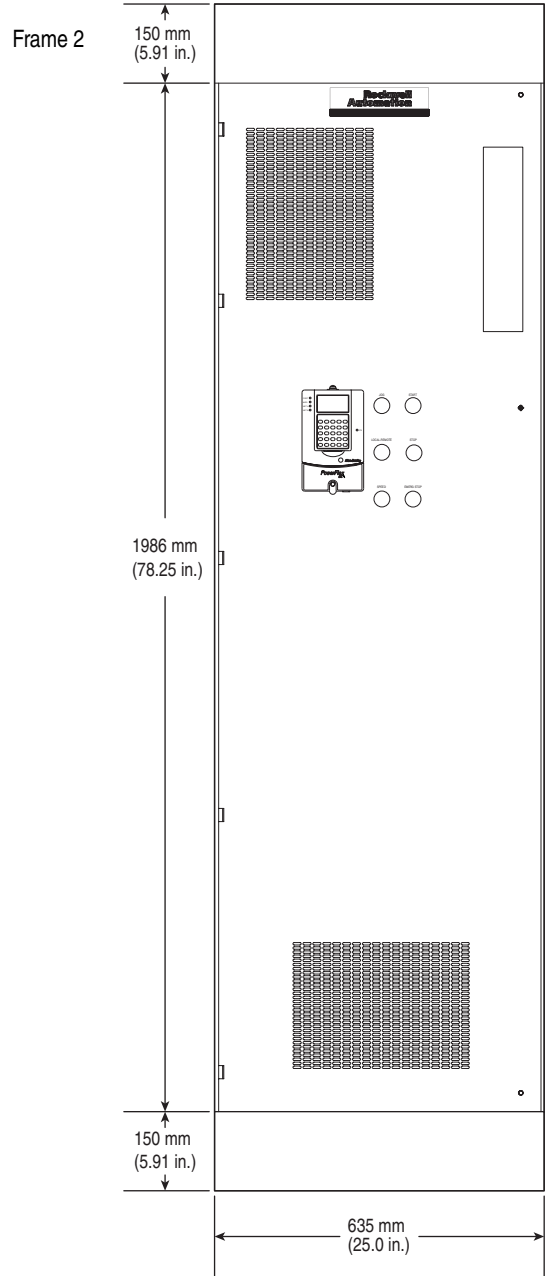
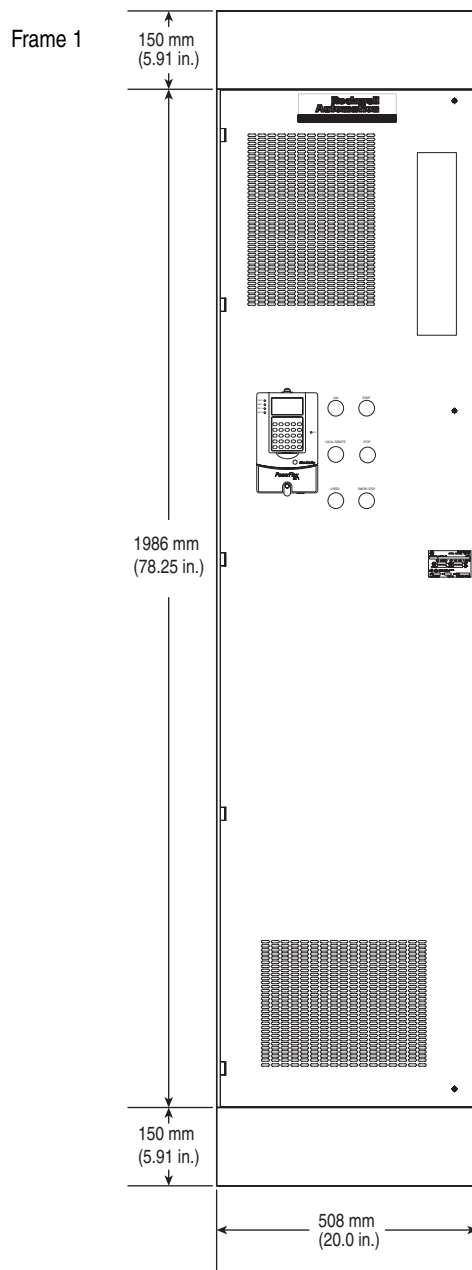

Configured Drive Enclosure Dimensions

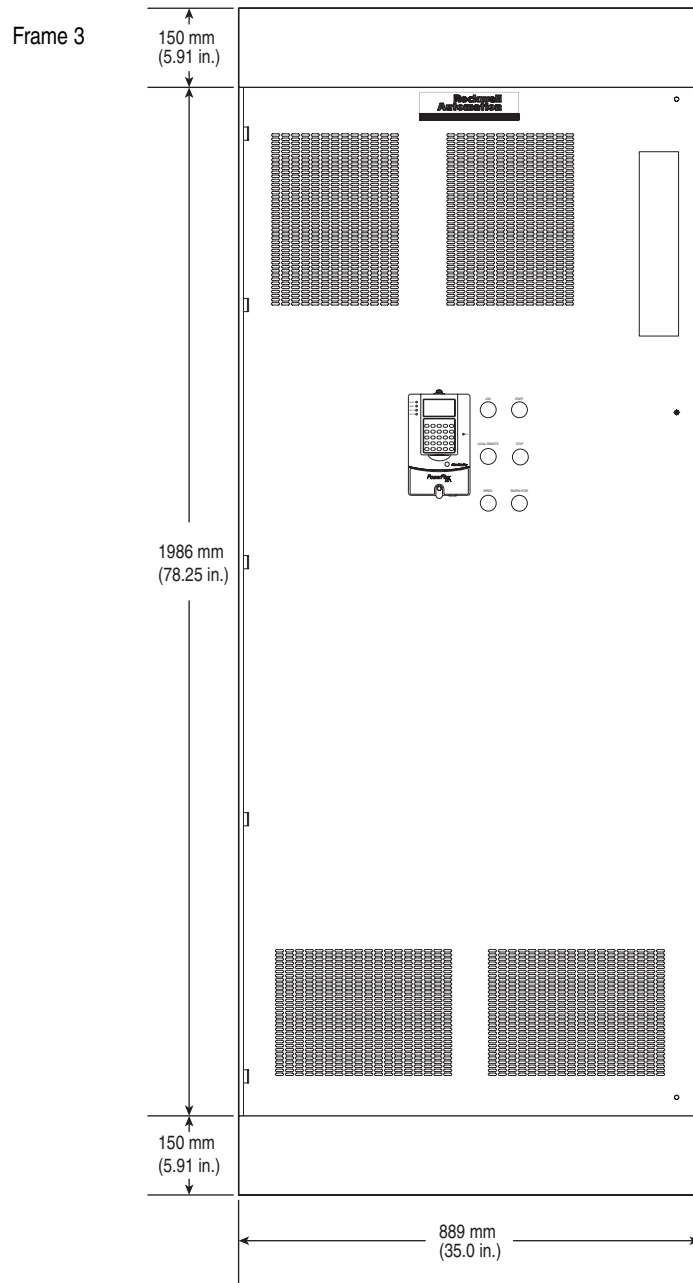

Configured Drive Enclosure Dimensions, Continued



Specifications

Category	Specification
Agency Certification	 According to file E59272 for the series of the approved devices.
	 In conformity with the following European Directives: EMC Directive (2004/108/EC) Low Voltage Directive (2006/95/EC) Standards applied: EN 50178: 1997 EN 61800-3: 2004
	 Australian Communications and Media Authority In conformity with the following: Radio communications Act: 1992 Radio communications Standard: 2008 Radio communications Labelling Notice: 2008 Standards applied: EN 61800-3:2004
The drive is also designed to meet the following specifications: NFPA 70 - US National Electrical Code	

Category	Specification	
Drive Type	Full Wave Regen, 6 Pulse, Regulated Field Supply	
Protection	Heat Sink Thermistor:	Monitored by microprocessor overtemp trip
	Drive Overcurrent Trip	
	Software Overcurrent Trip:	200% of rated current (typical)
	Hardware Overcurrent Trip:	220-300% of rated current (dependent on drive rating)
	Line transients:	Up to 2000 volts peak per IEC 6100-4-5
	Control Logic Noise Immunity:	Showering arc transients up to 1500V peak
	Power Ride-Thru:	15 milliseconds at full load
	Logic Control Ride-Thru:	0.5 seconds minimum, 2 seconds typical
	Ground Fault Trip:	Phase-to-ground on drive output
Environment ⁽¹⁾	Short Circuit Trip:	Phase-to-phase on drive output
	Altitude:	1000 m (3300 ft) max. without derating. De-rate output power by 1.2% for every 100 meters (328ft) above 1000 meters (3300ft).
	Maximum Surrounding Air Temperature IP20, NEMA Type Open:	0...50° C (32...122° F), typical. De-rate 1.25% for every 1° C over 50° C (122° F), to 55° C (131° F). Additional cooling is required for temps. above 55° C.
	Storage Temp. (all const.):	-25 to 55 degrees C (-13 to 131 degrees F)
	Atmosphere:	Important: Drive must not be installed in an area where the ambient atmosphere contains volatile or corrosive gas, vapors or dust. If the drive is not going to be installed for a period of time, it must be stored in an area where it will not be exposed to a corrosive atmosphere.
	Relative Humidity:	Operating: 5 to 85% non-condensing Storage: 5 - 95% non-condensing
	Shock:	15G peak for 11ms duration (±1.0 ms)
	Vibration:	0.152 mm (0.006 in.) displacement, 1G peak

(1) PowerFlex DC drives must be installed in a Pollution Degree 2 environment.

Category	Specification		
Drive Type	Full Wave Regen, 6 Pulse, Regulated Field Supply		
Electrical	Input Voltages:	230 to 690V AC +/- 10%, 3 Phase	
	Input Frequency:	50/60 Hz +/- 5%	
	Max. Rate of Change of Input Frequency:	2 Hz/Sec.	
	Armature Output Voltage:	Two Quadrant Drives	Four Quadrant Drives
		260V DC @ 230V AC	240V DC @ 230V AC
		470V DC @ 400V AC	420V DC @ 400V AC
		530V DC @ 440V AC	460V DC @ 440V AC
		560V DC @ 460V AC	480V DC @ 460V AC
		580V DC @ 480V AC	500V DC @ 480V AC
		680V DC @ 575V AC	600V DC @ 575V AC
810V DC @ 690V AC		720V DC @ 690V AC	
Output Horsepower (Cont.)	1.5...300 HP @ 230V AC 2...900 HP @ 460V AC 600...1250 HP @ 575V AC 600...1400 HP @ 690V AC		
Output Current:	4.1...1688A		
Overload Capability:	100% rated continuous current 150% rated current for one minute then fault 200% rated current for three seconds then fault		
Field Output Voltage	200V DC @ 230V AC 310V DC @ 400V AC 360V DC @ 460V AC Maximum field output voltage is 0.85 x AC input line voltage.		
Controller Current Overload:	150% rated current for one minute 200% rated current for three seconds		
Max. Short Circuit Rating:	100,000 A		
Control	Speed Regulation:*	All operating modes: Max. speed: 8000 rpm Digital reference resolution: 0.25 rpm Analog reference resolution: ≥ 0.25 rpm with Digital Incremental Encoder Speed feedback resolution 0.5 rpm Operating range better than 1000:1 rpm, bi-directional Performance Accuracy $\pm 0.02\%$ typical 170 rad/sec bandwidth	
		with DC Analog Tachometer Speed feedback resolution better than 2000:1 rpm Operating range better than 1000:1 rpm, bi-directional Performance accuracy $\pm 0.1\%$ 170 rad/sec bandwidth	
		with Armature Voltage Feedback Voltage feedback resolution better than 2000:1 rpm Operating range better than 100:1 rpm, bi-directional Performance accuracy: $\pm 2.0\%$ typical 80 rad/sec bandwidth *Subject to motor specs. and current loop tuning.	
Torque Regulation	Current feedback resolution better than 2000:1 rpm		
	Performance accuracy: 1.0% typical		
	500 rad/sec bandwidth		

Category	Specification	
Feedback Devices	Encoder	Type: Incremental, dual channel, two channel optional (with jumper), differential (recommended) or single-ended Input Voltage: Configurable for +2.5V - 5.2V (switch S21 in ENC_5 position) or +5.4V - 15.2V (switch S21 in ENC_12 position) Input Current: 4.5 mA / 6.8 - 10.9 mA each channel Quadrature: 90° ± 27° @ 25° C Duty cycle: 50% ± 10% Source/Sink capable Pulses Per Revolution: 100 to 32770 Maximum Frequency: 150 kHz Maximum Cable Length: Shielded, 150m (0.75 mm ²), 125m (0.5 mm ²), 55m (0.22 mm ²)
	DC Analog Tachometer	Input Voltage: 22.7, 45.4, 90.7, 181.6, & 302.9V max. Input Current: 8 mA full scale Maximum Cable Length: Shielded, depends on the installation, typical 150m.
Inputs	Analog Inputs	Three configurable, isolated, differential ±10V, 0-10V, 0-20mA or 4-20mA. Resolution: 11 Bit + sign
	Digital Inputs	Eight standard configurable, four additional configurable with the I/O Expansion circuit board. Max Voltage +30V DC input, 200mA (total current draw is the sum of encoder power, digital outputs and any other loads connected to terminal 19)
Outputs	Analog Outputs	Two standard configurable, two additional configurable with the I/O Expansion circuit board. Sampling rate 2 ms. ± 10V, 5mA, bipolar (current is not bipolar) Resolution: 11 Bit + sign
	Digital Outputs	Four standard configurable, four additional configurable with the I/O Expansion circuit board. + 30V, 50mA
	Relay Outputs	Two configurable, N.O. contacts Max. 250V AC, 1A AC1

Watts Loss

Watts loss data shown below is based on the rated current of the drive.

Frame A Drives Watts Loss and Fan Capacity

Drive Current Rating Code ⁽¹⁾		Total Watts Loss	Fan				
@ 230 VAC	@ 460 VAC		Input Voltage	Rated Current	Air Flow Capacity (m ³ /h)		
7P0	4P1	131	(no fan)				
9P0	6P0						
012	010						
020	014						
-	019						
029	027	186	(Internal power supply)				
038	035	254				80	
055	045						
-	052						
073	073	408				160	
093	086	476					
110	-	553					
-	100						
-	129						

⁽¹⁾ Refer to [Catalog Number Explanation on page 6](#), positions 8-10 for corresponding drive HP rating, armature amp rating and field amp rating.

Frame B Drives Watts Loss and Fan Capacity

Drive			Fans		
Current Rating Code ⁽¹⁾	AC Input Voltage	Total Watts Loss	Input Voltage	Rated Current	Air Flow Capacity (m ³ /h)
146	230	781	(Internal power supply)		320
180					
218		939			
265		1038			
360		1693			
434	460		680		
167		781			
207		939			
250		1038			
330		1248			
412		1693			
					320

⁽¹⁾ Refer to [Catalog Number Explanation on page 6](#), positions 8-10 for corresponding drive HP rating, armature amp rating and field amp rating.

Frame C Drives Watts Loss and Fan Capacity

Drive			Fans ⁽²⁾		
Current Rating Code ⁽¹⁾	AC Input Voltage	Total Watts Loss	Input Voltage (VAC)	Rated Current (A)	Air Flow Capacity (m ³ /h)
521	230	2143	230	0.75	1050
700		2700			
495	460	2143			
667		2590			

⁽¹⁾ Refer to [Catalog Number Explanation on page 6](#), positions 8-10 for corresponding drive HP rating, armature amp rating and field amp rating.

⁽²⁾ Fans on frames C drives must be powered by an external 230 V AC, 50/60 Hz power supply, connected to terminals U3 and V3.

Frame D Drives Watts Loss and Fan Capacity

Drive			Fans(2)		
Current Rating Code(1)	AC Input Voltage	Total Watts Loss	Input Voltage (VAC)	Rated Current	Air Flow Capacity (m ³ /h)
875	230	2694	230	2.4A@50Hz and 3.3A@60Hz	2400
1K0		3284			
830	480	3200			
996R		3568			
1K1		4189			
1K3		5229			
1K4		5117			
810	575	3122			
1K0		3819			
1K2		4679			
1K3		4879			
1K6		5720			
678	690	3174			
791		3582			
904		4028			
1K0		4064			
1K1		4509			
1K2		5368			
1K4		5543			
1K5		5886			

(1) Refer to [Catalog Number Explanation on page 6](#), positions 8-10 for corresponding drive HP rating, armature amp rating and field amp rating.

(2) Fans on frames D drives must be powered by an external 230 V AC, 50/60 Hz power supply, connected to terminals U3 and V3.

Reference Materials

For additional PowerFlex DC data and general drive information, refer to the following publications:

Title	Publication	Available Online at . . .
PowerFlex Digital DC Drive User Manual	20P-UM001...	www.rockwellautomation.com/literature
A Global Reference Guide for Reading Schematic Diagrams	100-2.10	
Guarding Against Electrostatic Damage	8000-4.5.2	
Preventive Maintenance of Industrial Control and Drive System Equipment	DRIVES-TD001...	
Safety Guidelines for the Application, Installation and Maintenance of Solid State Control	SIGI-1.1	

For other information, contact Allen-Bradley Drives Technical Support:

Title	Online at . . .
Allen-Bradley Drives Technical Support	www.ab.com/support/abdrives

www.rockwellautomation.com

Power, Control and Information Solutions Headquarters

Americas: Rockwell Automation, 1201 South Second Street, Milwaukee, WI 53204-2496 USA, Tel: (1) 414.382.2000, Fax: (1) 414.382.4444
Europe/Middle East/Africa: Rockwell Automation, Vorstlaan/Boulevard du Souverain 36, 1170 Brussels, Belgium, Tel: (32) 2 663 0600, Fax: (32) 2 663 0640
Asia Pacific: Rockwell Automation, Level 14, Core F, Cyberport 3, 100 Cyberport Road, Hong Kong, Tel: (852) 2887 4788, Fax: (852) 2508 1846