

PowerFlex 700 Sample Specification

Vector Control (Series B)

GENERAL

REFERENCES

The drive is designed to meet the following specifications:

- NFPA 70 - US National Electrical Code
- NEMA ICS 3.1 - Safety standards for Construction and Guide for Selection, Installation and Operation of Adjustable Speed Drive Systems.
- NEMA 250 - Enclosures for Electrical Equipment
- UL 508C - Underwriter's Laboratory
- CAN/CSA-C22 No. 14-M91. - Canadian Standards Association.
- IEC 146 - International Electrical Code.
- CMMA Specification #70 (Crane Manufacturers of America Association).

REGULATORY REQUIREMENTS

The drive conforms to the following requirements:

- NFPA 70
- IEC 146
- C-UL marking to provide an approved listing for Canadian users.
- UL listing
Manufacturer will furnish the product as listed and classified by Underwriter's Laboratories as suitable for the purpose specified and indicated.
- EN Standard/CE marked for the following directives (600V drives below 77 Amps have not been tested):

Low Voltage Directive (73/23/EEC)

EN50178 Electronic Equipment for use in power installations

EMC Directive (89/336/EEC)

EN61800-3 Adjustable Speed electrical power drive systems Part 3.

The drive has an internal EMC filter capable of meeting the Second Environment levels for the EMC directive without the need for additional components. First environment classification requires an additional, external filter.

- C-Tick EMC Standards for Australia / New Zealand
- SEMI 47 certification
- ATEX directive 94/9/EC. Group II Category (2) GD Applications with ATEX Approved Motors.
- RINA certification

QUALIFICATIONS MANUFACTURER:

Allen-Bradley entered the AC Variable speed drive market in 1980. Rockwell Automation / Allen-Bradley Standard Drives Business continues to specialize in the design and manufacturing of PWM Adjustable Frequency Drives.

SUPPORT:

Rockwell Automation maintains factory trained and authorized service facilities within 100 miles of the project and has a demonstrated record of service for at least the previous three years. Rockwell Automation employs full-time support personnel.

CERTIFICATION:

All Allen-Bradley drive manufacturing locations are certified to the ISO-9001 Series of Quality Standards as well as the ISO-14001 Environmental Standards. This insures all quality and corrective action procedures are documented and implemented with a goal of Total Customer Satisfaction.

PRODUCT

efesotomasyon.com

RATINGS

INPUT POWER:

The drive is available in three ranges and is self-adjustable to accept an input voltage range between;

200-240V AC, three phase +/-10%.

380-480V AC, three phase +/-10%.

500-690V AC, three phase +/-10%.

Displacement power factor ranges between 1.0 and 0.95, lagging, over the entire speed range. The efficiency of the drive is a minimum of 97% at full load and speed.

The drive is can be supplied with DC input voltages with rating that are equivalent to the AC voltages listed above.

The drive can be supplied as 6, 12 or 18 pulse in configured packages.

ENVIRONMENT:

Storage ambient temperature range: -40° C to 70° C (-40° to 158°F).

Operating ambient temperature range without derating:

IP0 / Open	0° C to 50° C (0° to 122° F)
IP20 / UL Type 1 (NEMA 1)	0° C to 40° C (0° to 104° F)
IP54 / UL Type 12 (NEMA 12)	0° C to 40° C (0° to 104° F).

The relative humidity range is 5% to 95% non-condensing.

Operating elevation: up to 1000 Meters (3,300ft) without derating.

Shock: 15G peak for 11ms duration

Vibration: 0.152 mm (0.006 inches) displacement, 1G peak

The drives can be Zero-Stacked (Mounted next to other drives with zero clearance between them).

OUTPUT POWER:

The output voltage is adjustable from 0 to rated motor voltage (230V, 400V, 460V, 575V or 690V). The output frequency range is adjustable from 0 to 420 Hz. The inverter section will produce a pulse width modulated (PWM) waveform using latest generation IGBTs.

REFLECTED WAVE

Drives have software to limit the reflected wave due to long cable lengths to a maximum of 2.25 times the bus voltage or 1600V, whichever is less, up to cable lengths of 600ft (183m). Hardware designs also limit peak voltages on the motor.

HARDWARE:

The drive hardware employs the following power components

- Diode or fully gated bridge on the input.
- DC bus inductor on all ratings
- Switching logic power supply operating from the DC bus.
- MOV protection - phase to phase and phase to ground with jumpers to remove the phase to ground unit when applicable.
- Common Mode Capacitors on all units with jumpers for removal when used on ungrounded systems, resistive grounded systems, and systems with regenerative units used as a bus supply or brake.
- Internal Common Mode Cores on the drive output - standard on all ratings (except 240V, <52A)
- Gold plated plug-in connections on printed circuit boards.
- Microprocessor based inverter logic isolated from power circuits.
- Latest generation IGBT inverter section.
- Customer Interface common for all horsepower ratings. LCD digital display standard with choices for programming keypad and operator keys options.
- The Main Control Cassette can be used on all drive ratings to optimize spare parts stocking and exchange.
- Common control connection for all ratings.
- Optimized for 4kHz carrier frequency.
- Device Peripheral Interface (DPI) for connection to common options.
- Status and Power LEDs viewable through the cover.
- Status LEDs for communications status, including embedded DPI status, adapter health and communications network status, viewable through the cover.

CONTROL LOGIC:

The drive is programmable or self-adjusting for the following:

- Operating the drive with motor disconnected.
- Controlled shut down, when properly fused, with no component failure in the event of an output phase to phase or phase to ground short circuit and annunciation of the fault condition.
- Advanced thermal manager to provide full protection of the power devices by reducing PWM frequency, and output speed.
- Adjustable PWM carrier frequency within a range of 2-10 kHz.
- Selectable Vector Control with Force Technology™, Sensorless Vector or V/Hz mode.
- Suitable for use on both Normal Duty and Heavy Duty loads.
 - Normal Duty ratings are
 - Rated Current continuously
 - 110% Overload capability for up to 1 minute
 - 150% Overload capability for up to 3 seconds
 - Heavy Duty ratings are
 - Rated Current continuously
 - 150% Overload capability for up to 1 minute
 - 200% Overload capability for up to 3 seconds
- Multiple programmable stop modes including - Ramp, Coast, Fast Brake, DC-Brake, Ramp-to-Hold and S-curve.
- Multiple acceleration and deceleration rates.
- All adjustments to be made with the door closed.
- Protection for loss of an input phase or loss of an output phase
- Adjustable output frequency up to 420 Hz.
- Adjustable Voltage Control Mode which allows independent control of voltage and frequency for non-motor applications.

TERMINAL BLOCKS:

Separate terminal blocks are provided for control and power wiring. Power terminal blocks are rated a minimum of 90 °C and marked for both inputs and outputs (R/L1, S/L2, T/L3 and U/T1, V/T2, W/T3)

POWER CONDITIONING:

The drive is designed to operate on an AC supply source that may contain line notching and up to 10% harmonic distortion. An input isolation transformer is not required for protection from normal line transients. If line conditions dictate the use of a transformer, the K factor should be 4.0 or less.

OPERATOR INTERFACE:

Interface to the drive is provided via a removable Human Interface Module (HIM) with integral display. This unit is a 7 line by 21-character backlit LCD display with graphics capability. It is used to display drive operating conditions, fault / alarm indications and programming information with full text support in multiple languages, including but not limited to English, German, French, Italian, Spanish, Portuguese and Dutch. The drive can also be programmed and display all speed values in either Hertz or RPM.

The display can be configured to display in three distinct sections.

1. The first section is a status display indicating direction, status, fault / alarm conditions and Auto / Manual mode.
2. The second section displays drive output frequency by default. This can be programmed by the user.
3. The third section can be configured to display either programming menus and information or a 2-line user display for simultaneously displaying two additional values using customized multi-lingual text and user scaled units. This section is also configurable as a "screen saver" with programmable timeout. When time expires, the LCD display automatically reverts to this display.

The LCD version is available in two styles:

- An IP20 / Type 1 drive mounted version that can also be used as a handheld terminal by connecting via a separate cable.
- An IP66 / UL Type 4X,12 remote mounted version for cabinet / panel mounting that is connected via cable.

The keypads for these include programming keys, drive operating keys (Start, Stop, Direction, Jog and Speed Control), numeric keys for direct entry and an ALT (alternate function) key to allow some of the more common drive programming or operating functions to be accessed directly without knowledge of programming structure. These ALT functions include S.M.A.R.T. Start for fast and easy commissioning, View selection, Auto Manual operation, HIM removal under power, and device selection for programming.

HARD-WIRED I/O:

Hardwired I/O is provided via I/O that resides in the Control Cassette and connects to the Main Control Board with a removable connector. Vector Control and Standard Control options are available. Vector Control is the primary offering.

Vector Control Cassette

The Vector Control cassette has dedicated digital I/O and analog I/O. These cassettes are available in two versions; one for 115 VAC digital I/O and one for 24V DC digital I/O. Both cassettes contain the following I/O points:

Analog I/O

- (2) differential, isolated $\pm 10V$ (bi-polar) / 20mA analog inputs , 11 bit plus sign, 160V common mode noise rejection
Both Inputs are fully user programmable for a variety of uses including frequency command, process loop inputs and others. Inputs are programmable for function, scaling (including invert), offset, signal loss detect and square root.
- (2) single-ended, $\pm 10V$ (bi-polar)/20 mA analog output, 11 bit plus sign. Both are fully user programmable to be proportional to one of 25 process parameters including output frequency, output current, encoder feedback, output power and others. Programming is available to select either absolute or signed values of these parameters.
- (1) input for motor protection thermistor (1.8k ohm PTC). Drive will provide fault protection if temperature exceeds protection value.

Digital I/O

- (6) digital inputs 24V DC or 115 VAC
inputs are configurable as sink or source. All inputs are individually programmable for functions from a list of 57 that include Start (3-wire control), Run (2-wire control), Stop, External fault, Speed select, Jog, Process PI functions, Level-sensitive Run and others. 24V Inputs draw 10 mA each and require a 20 V minimum for "ON" state and a maximum of 5 V for "OFF" state. 115V inputs draw 5 mA each and require a 100V minimum for "ON" state and a maximum of 30 V for "OFF" state.

One input can be set by a jumper to be a Hardware Enable. In this state, no microprocessor control is involved with disabling the drive outputs.

- (3) relay outputs , (1 - form C, 1 - form B, 1- form A)
Contact output ratings are 240 V AC/30V DC, and require 10mA minimum clearing current,. Both relays are programmable to 57 different conditions including Fault, Alarm, At Speed, Drive Ready, PI Excess Error and others. Also available are timers for each output that can control the amount of time, after the occurring event, that the output relay actually changes state. Each output has on-delay and off –delay timers relative to the function assigned to the input.

ENCODER FEEDBACK:

One incremental encoder interface option is provided. This option is selectable to receive either 5V or 12V from an encoder with a maximum of 250kHz. The encoder interface also has the ability to power the encoder. Minimum high state voltage is 3.5Vdc (5V mode) and 7.0Vdc (12V mode). Maximum low state voltage is 1Vdc (for both 5V and 12V modes). This encoder option can accept three channels (A, B and Z). The Z input can be used as a pulse input.

REFERENCE SIGNALS:

The drive is capable of the following speed reference signals:

- Digital MOP
- Jog
- HIM (Program/Control panel)
- Analog Input signals (2)
- Preset Speeds (7)
- Communication module commands
- Encoder Feedback
- Pulse Input (through Z-channel of encoder)

Analog input references are independently scaleable, both from the analog input side and from the speed reference side. A bi-polar analog signal (-10V to + 10V) may also be used to control direction.

The drive has over speed protection in the event that the output frequency exceeds the maximum reference by a specified amount.

All reference signals may have a trim signal applied to them for finer resolution and accuracy. Trim source and amount is programmable.

LOSS OF REFERENCE:

The drive is capable of sensing the following reference loss conditions;

- Remote potentiometer wiper loss
- 2-10V DC signals below 1 volts (reset at 1.5 volts)
- 4-20ma signals below 2 ma (reset at 3 mA)

In the event of loss of an analog input reference signal, the drive is user programmable to the following:

- Fault the drive
- Alarm and maintain last reference
- Alarm and go to preset speed
- Alarm and go to minimum speed
- Alarm and go to maximum speed
- Alarm and maintain last output frequency

Signal loss detection is available regardless of the function of the analog input.

ACCELERATION/DECELERATION:

Accel/Decel settings provide separate adjustments to allow either setting to be adjusted from 0.0 seconds to 3600.0 seconds. A second set of remotely selectable Accel/Decel settings is accessible through digital inputs. Programming capability allows the user to produce acc/dec profiles with linear or "S-Curve" characteristics that provide changing accel/dec rates. S-Curve profiles are adjustable.

ADJUSTMENTS:

The digital interface is used for all set-up, operation and adjustment settings. All adjustments are stored in nonvolatile memory (EEPROM). No potentiometer adjustments are used. The drive provides EEPROM memory for factory default values and user stored drive configurations.

AUTO ECONOMIZER:

This feature automatically reduces the output voltage when the drive is at a constant speed and partial load. The voltage is reduced to minimize flux current in a lightly loaded motor thus reducing kW usage. If the load increases, the drive will automatically return to normal operation.

AUTO / MANUAL MODE:

The Human Interface Module (HIM) shall have the ability to switch between Auto (remote signals) and Manual (local control from the HIM buttons) for both speed reference and start control. Auto / Manual transfer of either speed reference, start control, or both, shall be programmable. The feature shall be compatible with both two-wire and three-wire digital input run / start assignments.

The user has the choice of preloading the HIM with the current "auto" frequency reference before transferring control to allow for smooth transitions without speed "jumps".

AUTO RESTART:

The drive provides up to nine automatic fault reset and restarts following a fault condition before locking out and requiring manual restart. The automatic mode is not applicable to a ground fault, shorted output faults and other internal microprocessor faults. The time between restarts is adjustable from 0.5 seconds to 10800.0 seconds.

BRAKING OPTIONS:**Dynamic Braking**

The drives have either a standard or optional built in 7th IGBT for use as a dynamic braking chopper. This IGBT can provide at least 100% braking torque on a continuous basis. Drives less than 30 HP, 480V also have an optional "drive mounted" dynamic braking resistor for low level braking applications and interactive software to protect the "internally" mounted resistor from abuse. If the resistor's duty cycle or power rating is exceeded, the drive software manages the operation of the 7th IGBT to bring the loading below the resistors maximum level.

If applications require additional braking, the 7th IGBT is capable of driving an externally mounted resistor "cage" that can provide maximum DB capability up to the drive's rating. Resistor protection for external cages shall reside in the cage itself.

Flux Braking

The drive can provide additional braking power by eliminating additional regenerative energy as flux in the motor. This can be used during all decelerations including stopping.

Fast Braking

The drive can provide additional stopping power by using advanced slip control and eliminating additional regenerative energy as in the motor. This can be used for stopping actions.

BUS REGULATION:

DC Bus regulation is available to reduce the possibility of drive overvoltage trips due to regenerative conditions. The drive's reaction to a Bus voltage increase is programmable to one of 5 options.

Disabled:	Faults the drive on Overvoltage Fault
Adjust Frequency :	Adjusts the drive's output frequency to maintain bus voltage at a predetermined regulation level.
Dynamic Brake:	Dissipates the excess energy on the bus through the internal DB chopper and connected resistor.
Both – DB 1st	Begins by actuating the dynamic brake. If more response is needed, the drive will then adjust the output frequency.
Both – FRQ 1st	Begins by adjusting the output frequency. If more response is needed, the drive will then actuate the dynamic brake

Two bus regulation levels are available and are accessible through the digital inputs.

COMMUNICATIONS

DPI™ Peripheral INTERFACE

The drive has a Drive Peripheral Interface (DPI), which allows up to 4 independent peripherals to be connected to the drive at one time. This protocol operates between 125K and 500k baud and allows for connection to other networks via third party suppliers. Connection and identification of DPI port addresses requires no user adjustments.

COMMUNICATIONS INTERFACE:

The drive has the capability for either internally mounted or externally mounted communications interface cards. Internal cards use drive power and can operate at higher speeds. Externally mounted cards are separately powered and connected to the drive via a cable. The following are available:

- DeviceNet
- EtherNet/IP
- ControlNet Coax
- ControlNet Fiber
- Remote I/O
- Others - Other open control and communication network interface cards are available, including Profibus and Interbus-S.

CONTROL MODE:

Programming provides the ability to select either Vector Control with ForceTechnology, Sensorless Vector or V/Hz modes. The Vector Control and Sensorless Vector modes use motor nameplate data plus motor operating data such as IR drop, nominal flux current and flux up time to tune the motor / drive for optimum torque performance. The volts per hertz mode can be programmed for constant torque, fan/pump curve, or full custom patterns.

All three modes can be used with an encoder feedback option for tighter speed regulation.

CURRENT LIMIT:

Programmable current limit from .1 amps to 150% of drive rated amps. Current limit is active for all drive states; accelerating, constant speed and decelerating. Both the source of the current limit value and the gain for responsiveness adjustment are programmable. The drive employs PI regulation with an adjustable gain for smooth transition in and out of current limit.

DROOP CONTROL:

Drives have the ability to reduce output speed based on load. This assists with applications such as load sharing.

FAULT MEMORY:

The last eight fault codes with respective times are stored in the fault buffer. In addition, information about the drive's condition at the time of the last fault such as operating frequency, output current, dc bus voltage and 27 other status conditions are stored at the time of fault. Information is maintained in the event of a power loss. A power up marker is also provided at each power up time to aid in analyzing fault data.

The last eight alarm codes are also stored for additional troubleshooting reference.

FLYING START:

The drive is capable of determining the speed and direction of a spinning motor and adjusts its output to "pick-up" the motor at the rotating speed. This advanced feature can connect to a spinning motor almost instantaneously. It does not rely on a slower speed search algorithm.

INERTIA RIDE THROUGH:

The drive can respond to a loss of AC input power by adjusting the output frequency to create a regenerative situation in the motor. This regenerated energy recaptures the mechanical energy and converts it to electrical energy to power the drive logic during the power outage. This allows the drive to retain control of the motor during the power outage. Performance is based on the amount of system inertia and the length of the outage. The amount of voltage drop required to trigger inertia ride through and the level at which regulation occurs are both adjustable. Inertia Ride Through can be enabled or disabled via programming.

LIMIT SWITCH INPUTS:

Digital inputs can be selected to accept end limit switches and decel limit switches. When an end limit switch is opened, it will stop the drive and not allow it to proceed past this switch. It can operate in the reverse direction. When a decel limit switch is opened, it will slow the drive to a preset speed in the direction of travel but allow the normal reference speed in the opposite direction.

LINKS (PARAMETER LINKING):

The drive includes the ability to link parameters to pass values to other parameters. This provides additional flexibility for process or machine control.

MEMORY STORAGE:

The drive stores the factory default settings in non-volatile memory (EEPROM) so that the user can return the drive to a known state. Additional memory storage locations in the drive, known as User Sets can also be stored in the drive's non-volatile memory. Three User Set locations are offered. The user can name the sets per the process / application and recall the configuration to active drive memory as needed. These User Sets can also be activated dynamically via digital inputs or communication networks.

MOTOR OVERLOAD PROTECTION:

The drive will provide UL Listed Class 10 motor overload protection to comply with N.E.C. Article 430. Overload protection is speed sensitive and adjustable. To accommodate a variety of motors with different speed range capabilities, the frequency at which the overload begins to derate is programmable. Two different levels of accumulated overload can be signaled as alarm conditions, allow the user to adjust a process to eliminate an overload trip. A parameter is available to directly read the level of accumulated overload.

POSITION INDEXING / SPEED PROFILING:

The drive has a 16 step index array to allow positioning and speed profiling control. Homing capability is provided either to a marker pulse or digital input.

An integral position regulator provides point-to-point positioning. These moves can be incremental or absolute (referenced to a home position) using an incremental encoder.

The drive can also operate as a speed profiler providing basic positioning via digital inputs or velocity profiling via digital inputs, time, encoder counts or parameter levels.

PROCESS PID CONTROL:

The internal process PID regulator has proportional, integral and derivative gain adjustments as well as error inversion and output clamping functions. The feedback can be configured for normal or square root functions. If the feedback indicates that the process is moving away from the setpoint, the regulator will adjust the drive output until the feedback equals the reference. Process control can be enabled or disabled with a hardwired input. Transitioning in and out of process control can be tuned for faster response by preloading the integrator.

Protection is provided for a loss of feedback or reference signal. A signal can also be provided to indicate that excess error exists.

RIDE THROUGH:

The control logic is capable of "riding through" a power outage of at least 2 seconds in duration. The inverter section is shut off after an 18% drop in bus voltage to conserve power for the drive logic. The ride-through method and trigger point are adjustable by the user.

SCALE BLOCKS:

The drive includes four scale blocks which allow gain and offset control of any analog value.

SPEED REGULATION:

The programmable speed regulation modes include the following:

- Open Loop
- Slip Compensation with speed regulation from 0.1% to 0.5% depending on selected motor control mode
- Encoder feedback control with speed regulation from 0.001% to 0.1% depending on selected motor control mode
- Process PID control

SKIP FREQUENCIES:

Three adjustable set points that lock out continuous operation at frequencies, which may produce mechanical resonance, are provided. The set points have a bandwidth adjustable from 0Hz to 60Hz.

START AT POWER UP:

A user programmable restart function is provided to automatically restart the equipment after restoration of power after an outage. A maintained 2-wire start input is required for this function.

START UP ROUTINES:

Start Up Routines allow the user to commission the drive more quickly and accurately. Two type of routines exist:

S.M.A.R.T. Start
Assisted Start Up

S.M.A.R.T. Start is accessible by using the "ALT" function key on the LCD HIM. This simple 2-keystroke access brings up a list of parameters needed to program the eight most commonly adjusted drive functions. They include Start, Stop, Minimum Speed, Maximum Speed, Acceleration Time, Deceleration Time, Reference source (speed command) and Electronic Overload setting for the motor. No knowledge of parameter organization or access is required. S.M.A.R.T. Start can commission the drive in just a few minutes.

Assisted Start Up (Basic and Detailed) routine to aid the user in commissioning the drive asking simple Yes/No or “Enter Data” questions. The user is guided through the Start Up to reduce the amount of time necessary to get the drive “up and running”. The following are included in startup:

- Input Voltage Ratings
- Motor Data
- Motor Tests & Auto-tuning
- Speed/Torque Control & Direction Limits
- Speed Reference
- Start & Stop Modes
- Ramp setup
- Digital and analog I/O
- Application set-up (TorqProve, Oil Well Pumps, Positioning/Speed Profiling)

Auto-Tune is available independently or as a part of Start-up to aid in setup of the Sensorless vector and Vector control algorithms. Both a static (motor does not rotate) and a dynamic (motor rotates) routine are available. If tuning is not desirable, the drive can be instructed to calculate the values for tuning directly based on entered motor data.

SLEEP / WAKE MODE:

The Drive has the capability to use an analog input as a Start – Stop command. This input can be a separate input or also used as the speed reference. Signal level below the “sleep” level acts as a Stop Command and signal level above the “Wake” level acts as a Start Command. Sleep / Wake time and level are fully programmable and can be inverted.

TEST POINTS:

Two electronic test point parameters are available to examine data within the drive memory that is not available through other parameters.

TorqProve™ FOR LIFTING APPLICATIONS:

TorqProve automates the mechanical brake control which assures control of the load when transferring control between the drive and a mechanical brake. This feature also includes: Float capability, Fast Flux up, Brake Slip Detection, Microposition Speeds, Fast Stop, Load-Dependent Speed Control and Preset Torques.

TORQUE REGULATION:

The programmable torque regulation modes include the following:

- Encoderless control with +/-5% torque regulation.
- Encoder feedback control with +/-2% torque regulation.

Dimensions:

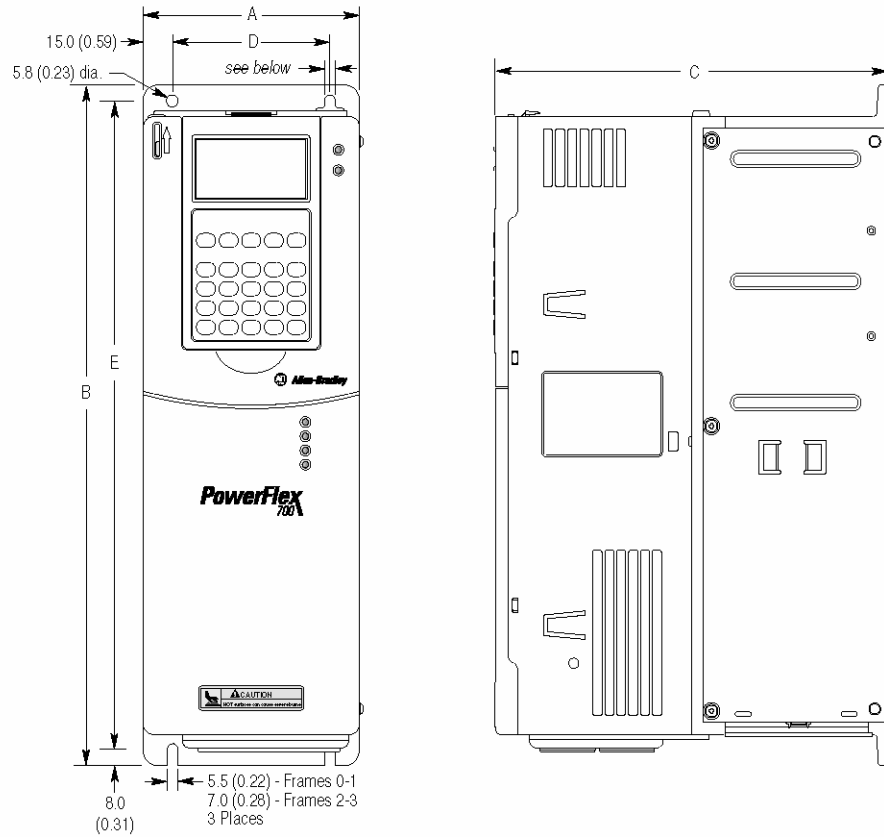

Dimensions are in millimeters and (inches).

Frame (see Table 1.B)	A	B	C	D	E	Weight ⁽¹⁾ kg (lbs.)	
						Drive	Drive & Packaging
0	110.0 (4.33)	336.0 (13.23)	200.0 (7.87)	80.0 (3.15)	320.0 (12.60)	5.22 (11.5)	8.16 (18)
1	135.0 (5.31)	336.0 (13.23)	200.0 (7.87)	105.0 (4.13)	320.0 (12.60)	7.03 (15.5)	9.98 (22)
2	222.0 (8.74)	342.5 (13.48)	200.0 (7.87)	192.0 (7.56)	320.0 (12.60)	12.52 (27.6)	15.20 (33.5)
3	222.0 (8.74)	517.5 (20.37)	200.0 (7.87)	192.0 (7.56)	500.0 (19.69)	18.55 (40.9)	22.68 (50)

⁽¹⁾ Weights include HIM and Standard I/O.

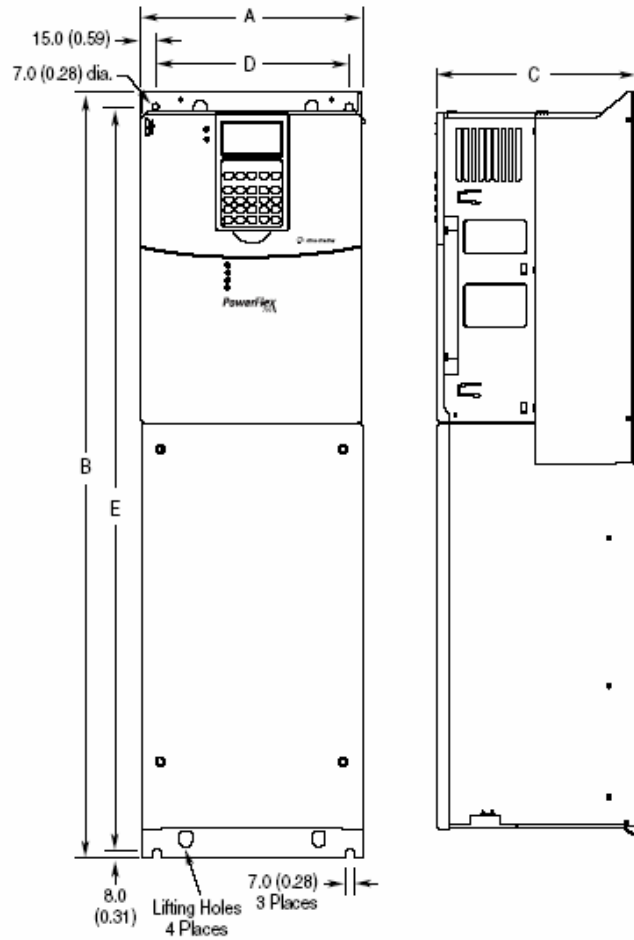

Dimensions are in millimeters and (inches)

Frame ⁽¹⁾	A (Max.)	B	C (Max.)	D	E	Approx. Weight ⁽²⁾ kg (lbs.)	
						Drive	Drive & Packaging
4	220.0 (8.66)	758.8 (29.87)	201.7 (7.94)	192.0 (7.56)	738.2 (29.06)	24.49 (54.0)	29.03 (64.0)

(1) Refer to [Table A.1](#) for frame information.

(2) Weights include HIM and Standard I/O.

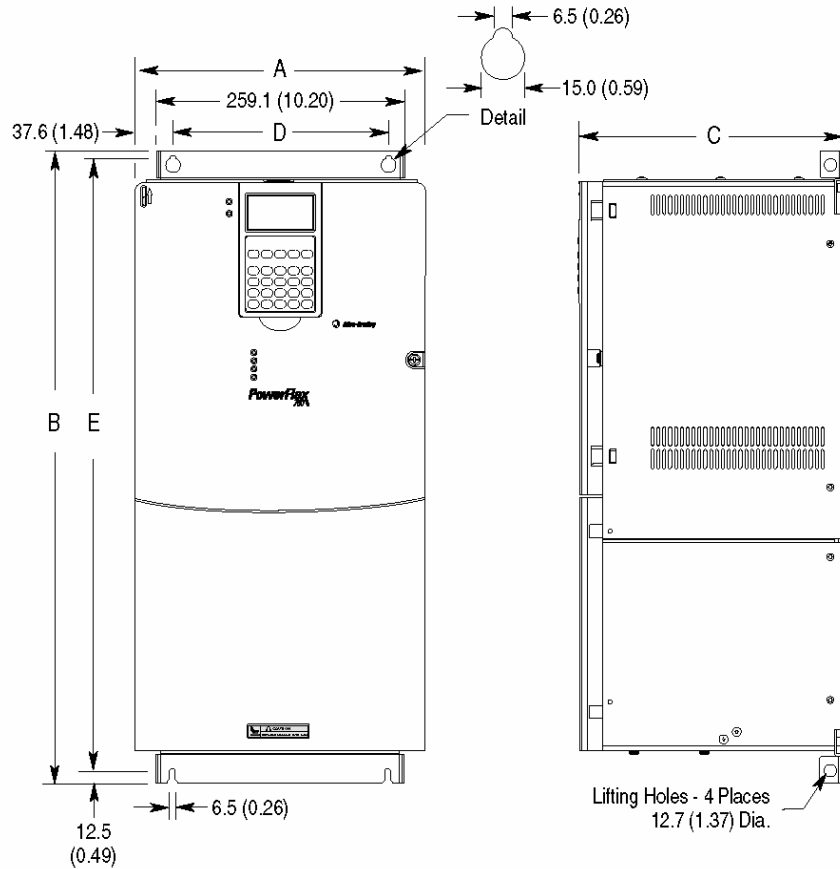

Dimensions are in millimeters and (inches).

Frame (see Table 1.B)	A (Max.)	B	C (Max.)	D	E	Approx. Weight ⁽¹⁾ kg (lbs.)	
						Drive	Drive & Packaging
5	308.9 (12.16)	644.5 (25.37) ⁽²⁾	275.4 (10.84)	225.0 (8.86)	625.0 (24.61)	37.19 (82.0)	42.18 (93.0)

(1) Weights include HIM and Standard I/O.

(2) When using the supplied junction box (100 HP drives Only), add an additional 45.1 mm (1.78 in.) to this dimension.

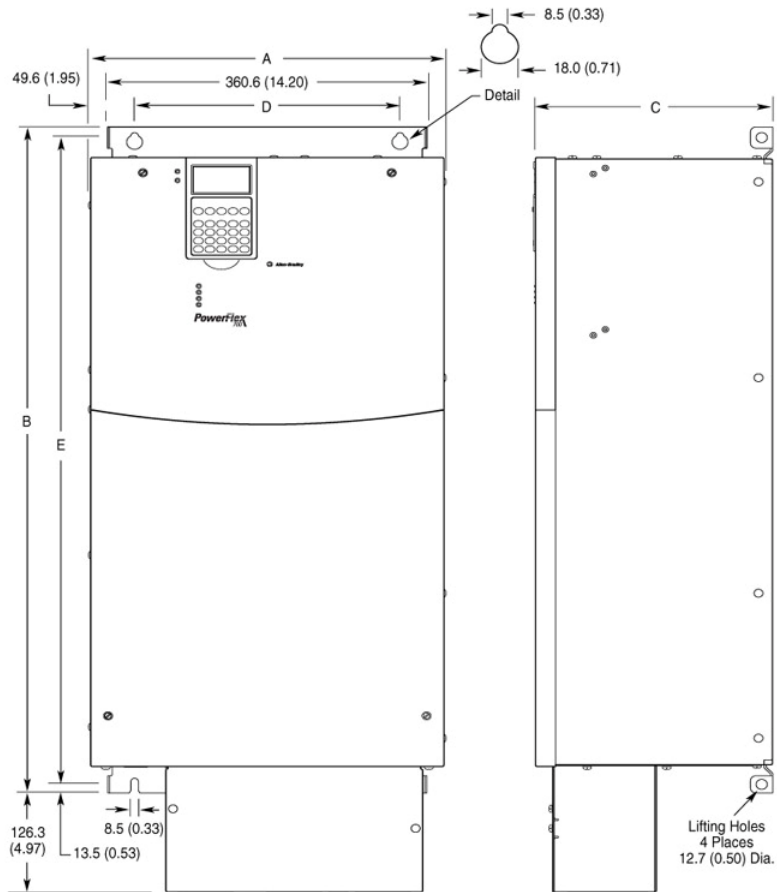

Dimensions are in millimeters and (inches)

Frame ⁽¹⁾	A (Max.)	B ⁽²⁾	C (Max.)	D	E	Approx. Weight ⁽³⁾ kg (lbs.)	
						Drive	Drive & Packaging
6	403.9 (15.90)	850.0 (33.46)	275.5 (10.85)	300.0 (11.81)	825.0 (32.48)	71.44 (157.5)	100.9 (222.0)

- (1) Refer to [Table A.1](#) for frame information.
- (2) Junction Box can be removed if drive is mounted in a cabinet.
- (3) Weights include HIM and Standard I/O. Add 13.60 kg (30.0 lbs.) for the following drives; 20BB260, 20BC260 and 20BD248.

Frame 5 NEMA Type 12 Standalone

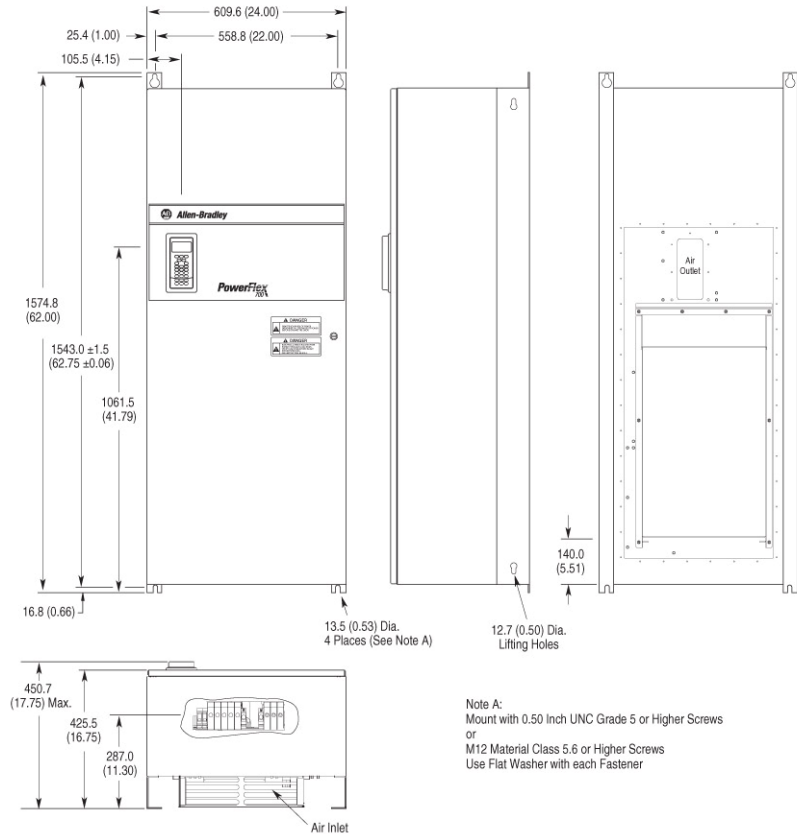

Dimensions are in millimeters and (inches)

Frame	Description	Approx. Weight ⁽¹⁾ kg (lbs.)	
		Drive	Drive & Packaging
5	Standalone	102.51 (226.0)	154.68 (341.0)

(1) Weights include HIM and Standard I/O.

Frame 5 NEMA Type 12 Flange Mount

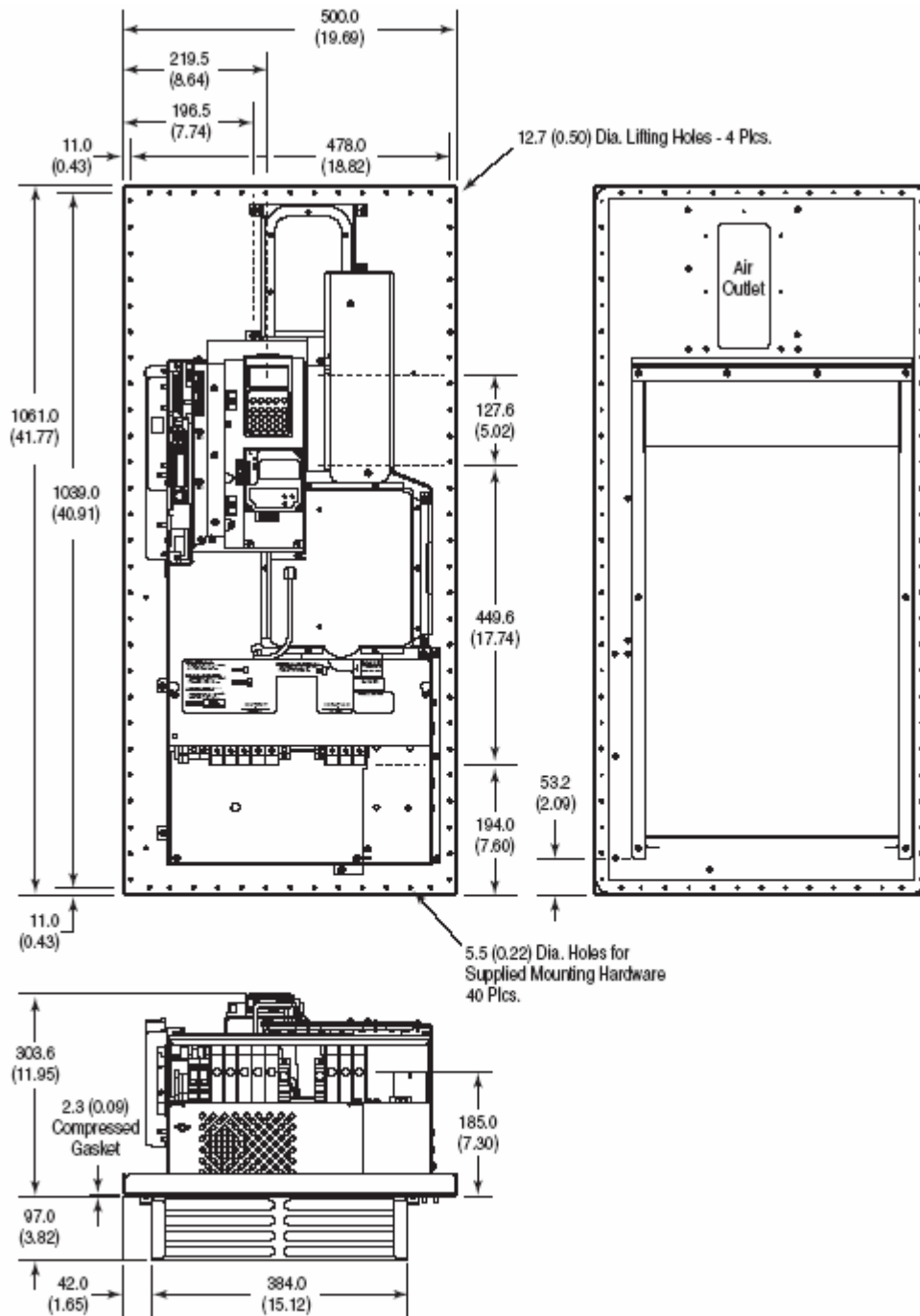

Dimensions are in millimeters and (inches)

Frame (1)	Description	Approx. Weight (2) kg (lbs.)	
		Drive	Drive & Packaging
5	Flange Mount	61.69 (136.0)	81.65 (180.0)

Frame 5 Flange Mount Cutout

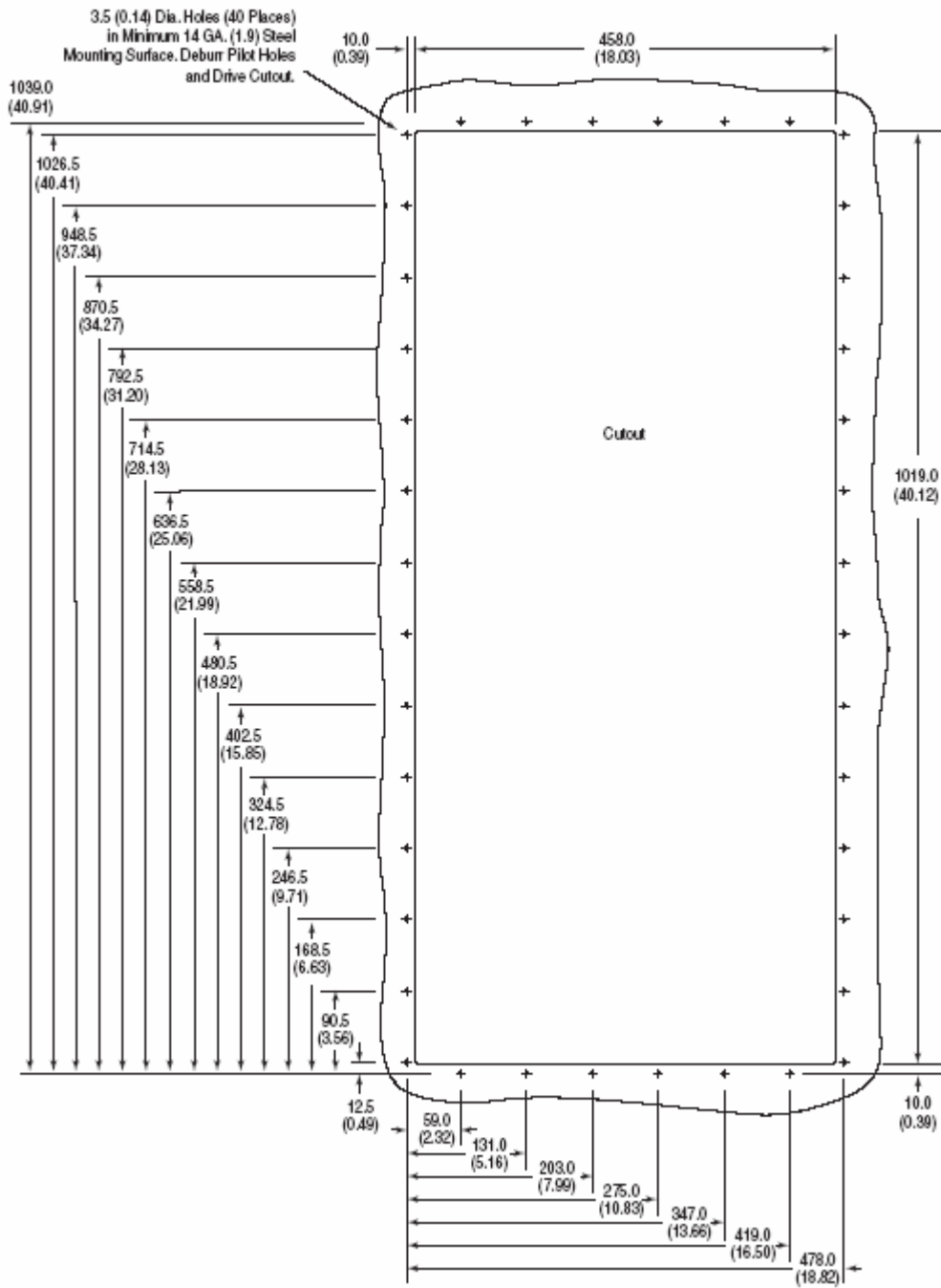

Frame 6 NEMA Type 12 Standalone

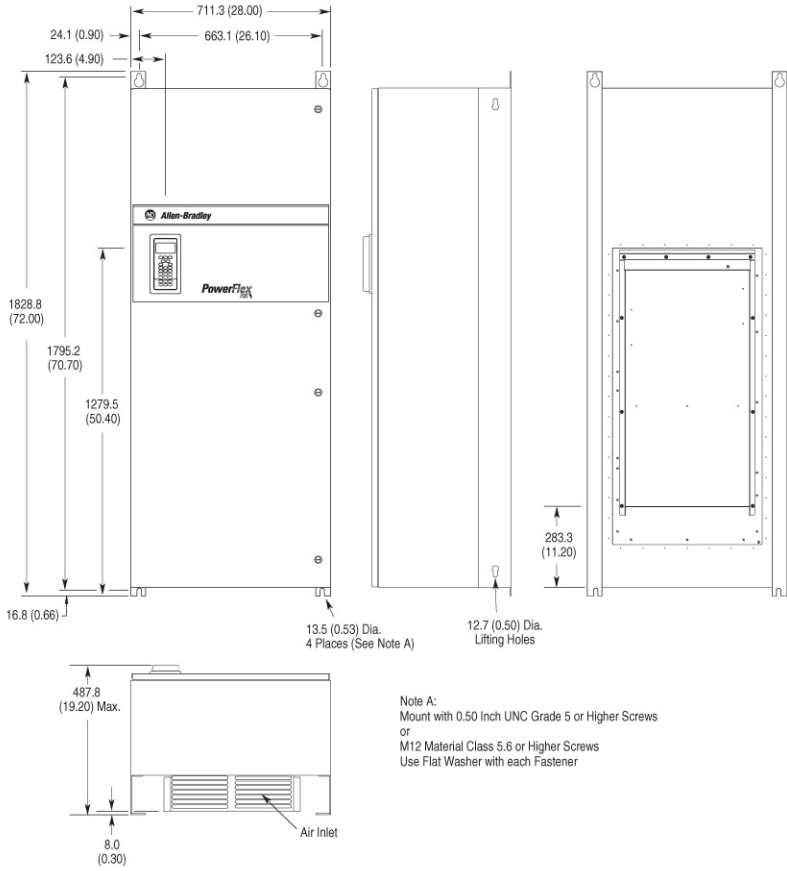

Dimensions are in millimeters and (inches)

Frame	Description	Approx. Weight ⁽¹⁾ kg (lbs.)	
		Drive	Drive & Packaging
6	Standalone	176.90 (390.0)	229.07 (505.0)

(1) Weights include HIM and Standard I/O.

Frame 6 NEMA Type 12 Flange Mount

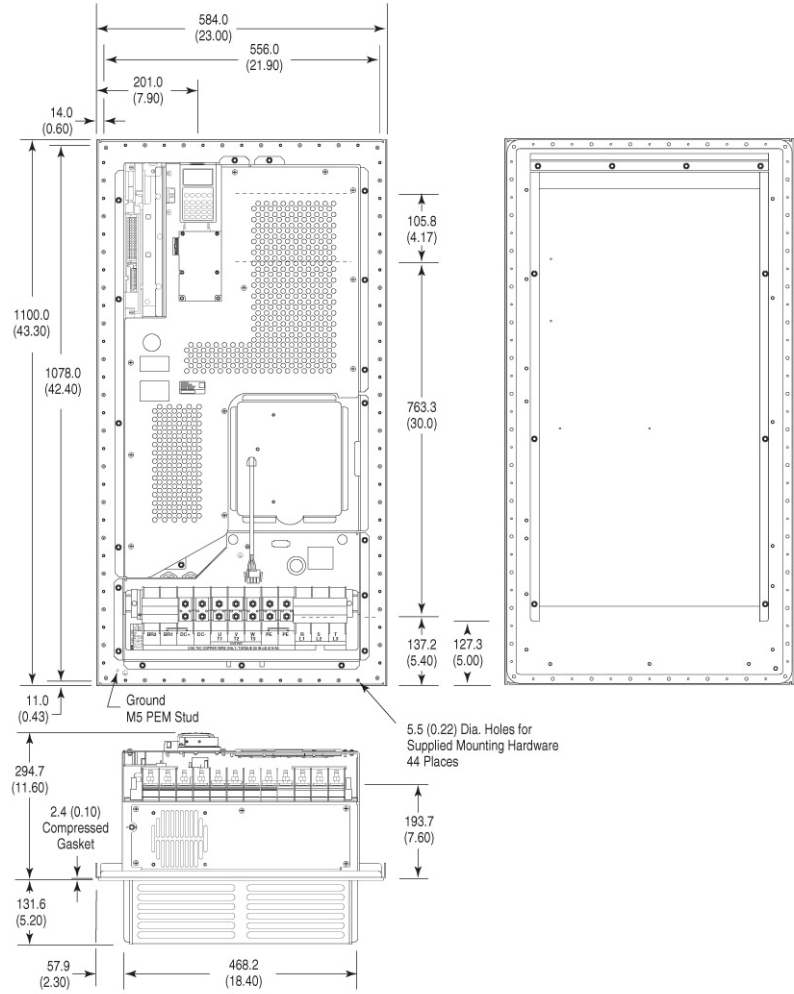

Dimensions are in millimeters and (inches)

Frame	Description	Approx. Weight ⁽¹⁾ kg (lbs.)	
		Drive	Drive & Packaging
6	Flange Mount	99.79 (220.0)	119.75 (264.0)

(1) Weights include HIM and Standard I/O.

Frame 2 Bottom View

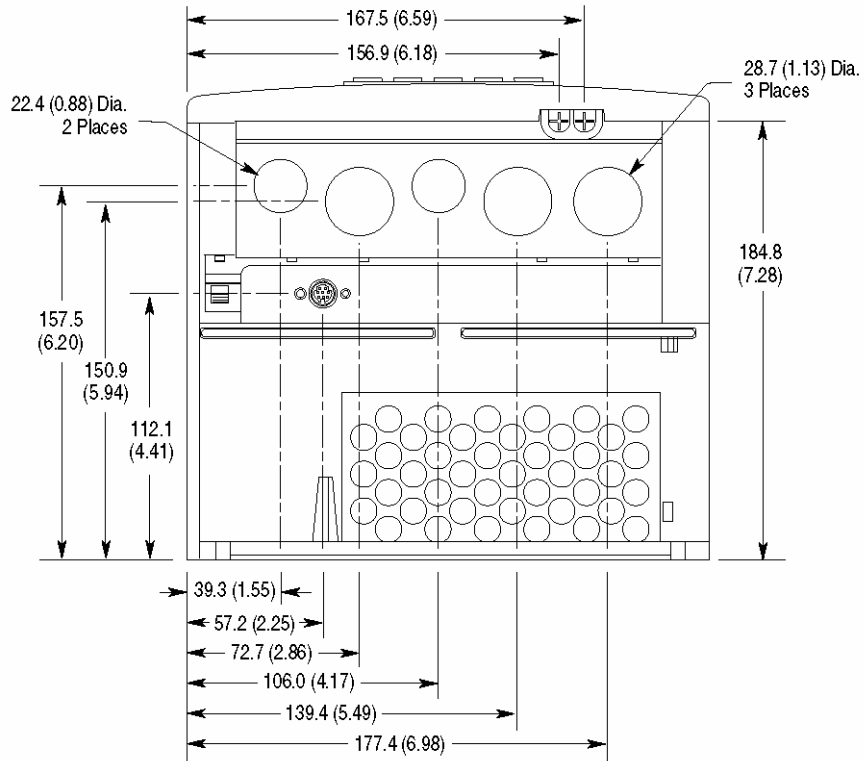

Dimensions are in millimeters and (inches)

Frame 3 Bottom View – All drives except 50 HP, 480V (37kW, 400 V)

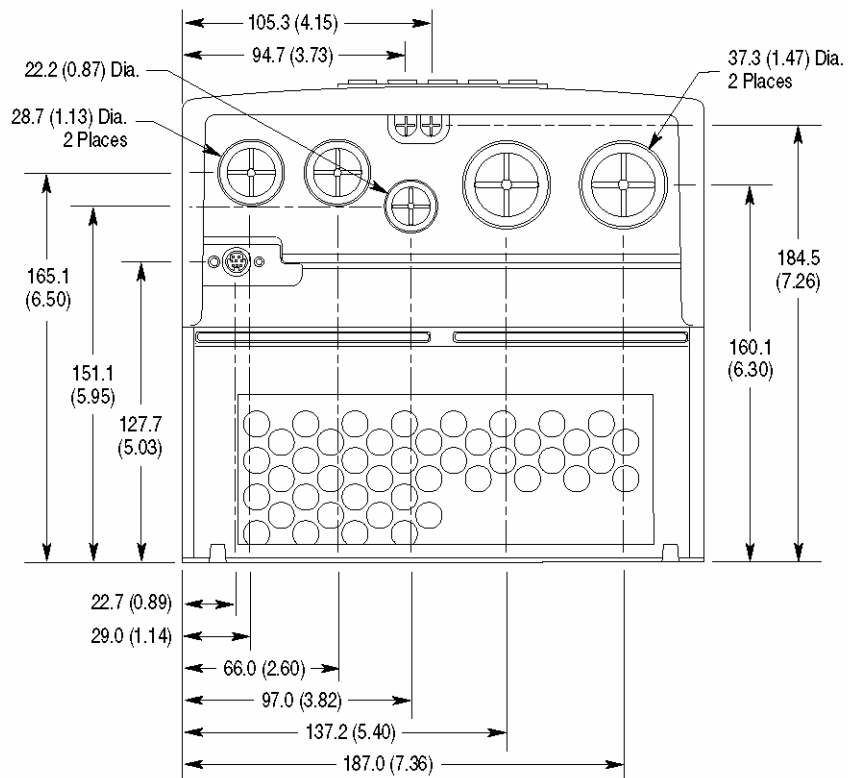

Frame 3 Bottom View – 50 HP, 480V (37kW, 400V)

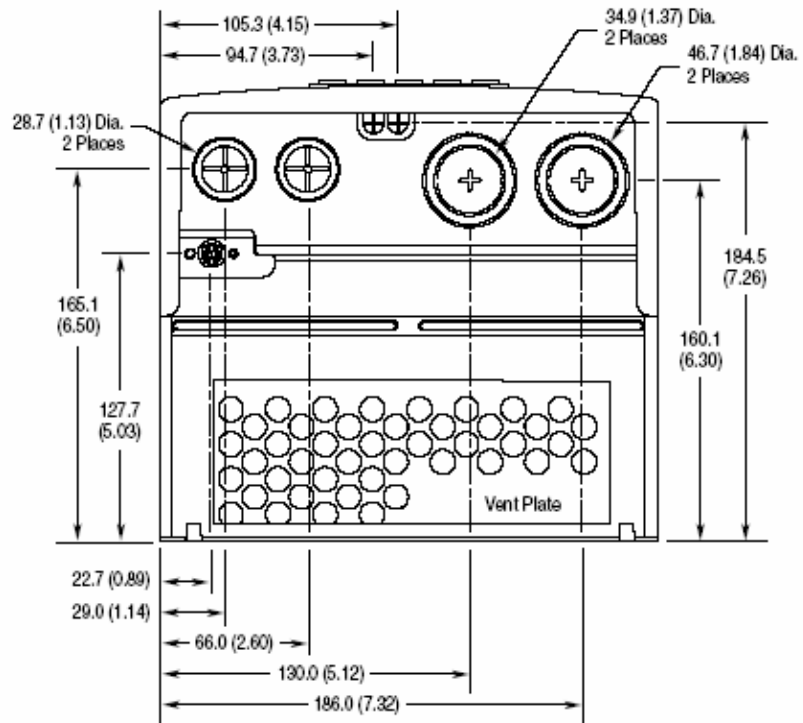

Frame 4 Bottom View – 60 HP, 480V (45kW, 400V)

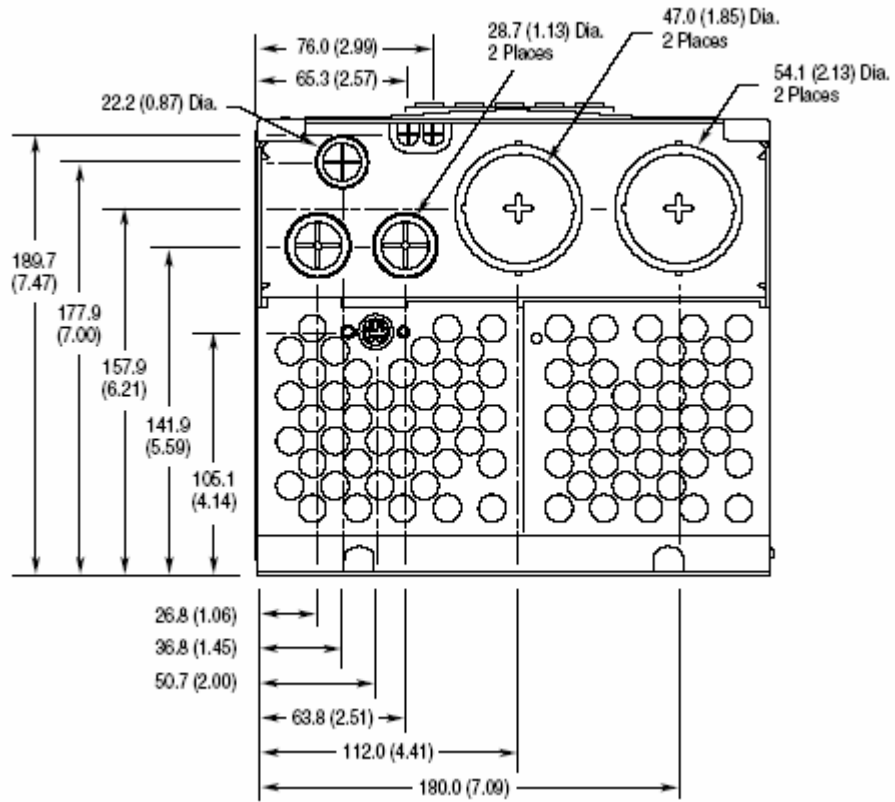

Frame 5 Bottom View – 75 HP, 480V (55 kW, 400V) Normal Duty

75 HP, 480V (55kW, 400V) Normal Duty Drive

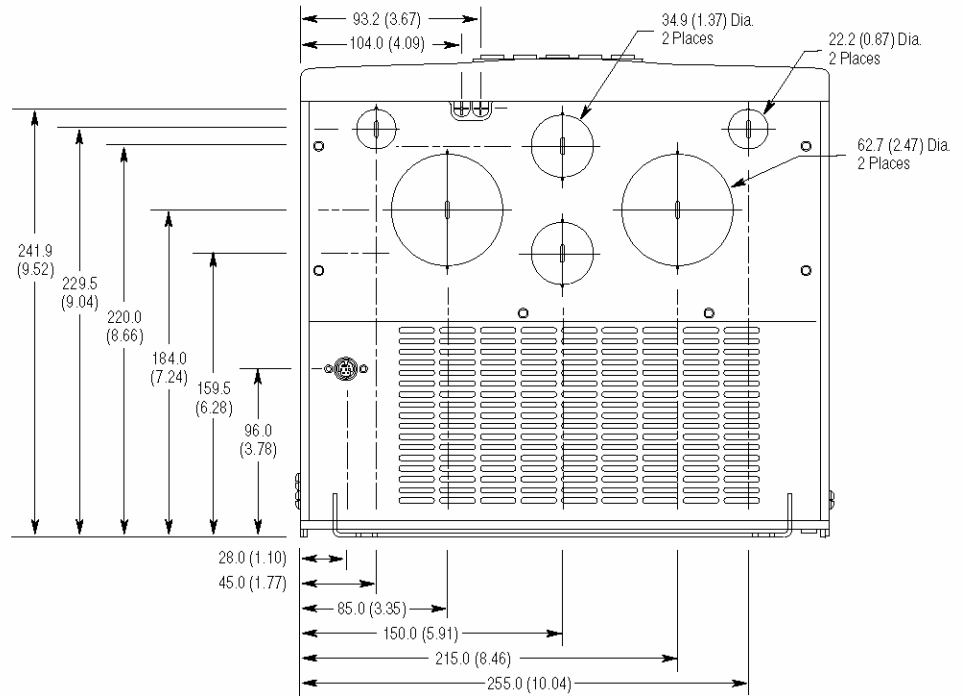

Frame 5 Bottom View –100HP, 480V Normal Duty

100 HP, 480V Normal Duty Drive

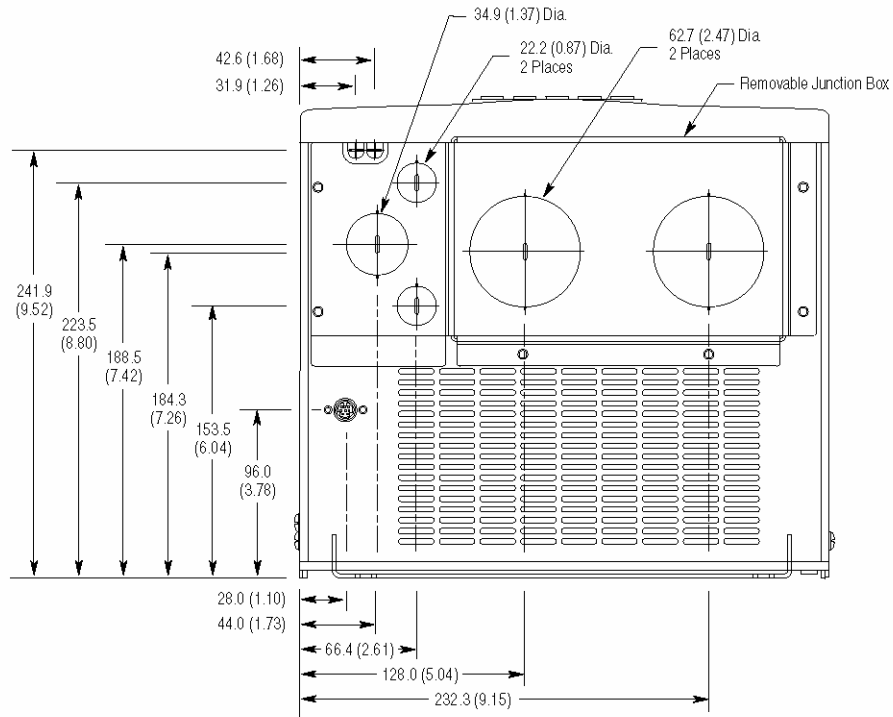

Dimensions are in millimeters and (inches)

Frame 6 Bottom View

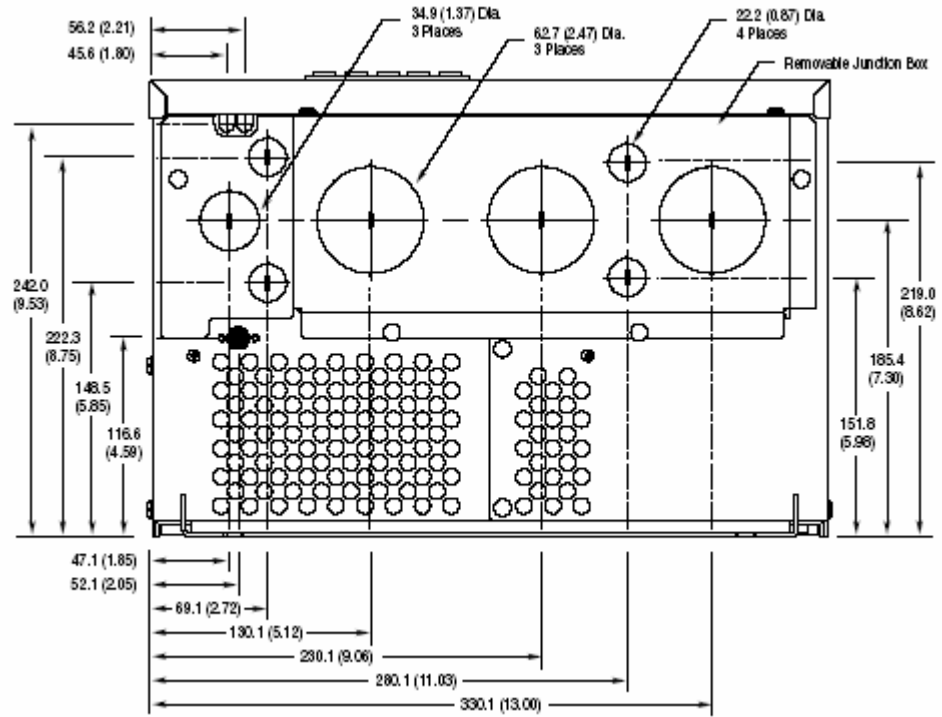

PowerFlex 700 Frames:

Frame	AC Input									
	208/240		400V		480V		600V		690V	
	ND HP	HD HP	ND kW	HD kW	ND HP	HD HP	ND HP	HD HP	ND kW	HD kW
0	0.5	0.33	0.37	0.25	0.5	0.33	1	0.5	-	-
	1	0.75	0.75	0.55	1	0.75	2	1	-	-
	-	-	1.5	0.75	2	1.5	3	2	-	-
	-	-	2.2	1.5	3	2	5	3	-	-
	-	-	4	2.2	5	3	7.5	5	-	-
	-	-	5.5	4	7.5	5	-	-	-	-
1	2	1.5	7.5	5.5	10	7.5	10	7.5	-	-
	3	2	11	7.5	15	10	15	10	-	-
	5	3	-	-	-	-	-	-	-	-
	7.5	5	-	-	-	-	-	-	-	-
2	10	7.5	15	11	20	15	20	15	-	-
	-	-	18.5	15	25	20	25	20	-	-
3	15	10	22	18.5	30	25	30	25	-	-
	20	15	30	22	40	30	40	30	-	-
	-	-	37	30	50	40	50	40	-	-
4	25	20	45	37	60	50	60	50	-	-
	30	25	-	-	-	-	-	-	-	-
5	40	30	55	45	75	60	75	60	45	37.5
	50	40	75	55	100	75	100	75	55	45
	-	-	-	-	-	-	-	-	75	55
	-	-	-	-	-	-	-	-	90	75
6	60	50	90	75	125	100	125	100	110	90
	75	60	110	90	150	125	150	125	132	110
	100	75	132	110	200	150	-	-	-	-

Frame	DC Input			
	540V		650V	
	ND HP	HD HP	ND HP	HD HP
0	-	-	0.5	0.33
	-	-	1	0.75
	-	-	2	1.5
	-	-	3	2
	-	-	5	3
	-	-	7.5	5
1	0.37	0.25	10	7.5
	0.75	0.55	15	10
	1.5	0.75	-	-
	2.2	1.5	-	-
	4	2.2	-	-
	5.5	4	-	-
	7.5	5.5	-	-
	11	7.5	-	-
2	15	11	20	15
	18.5	15	25	20
3	22	18.5	30	25
	30	22	40	30
	37	30	50	40
4	45	37	60	50
	-	-	-	-
5	55	45	75	60
	-	-	100	75
6	75	55	125	100
	90	75	150	125
	110	90	-	-
	132	110	200	150