

Allen-Bradley 1397 Open Chassis Dynamic Brake

Cat. Nos. 1397-DB-AxxxL — 240VDC
1397-DB-BxxxL — 500VDC

What This Option Provides

The 1397 Open Chassis Dynamic Brake kit provides a 1397 Dynamic Brake shipped as loose parts for customer assembly & installation.

Where This Option Is Used

Each Open Chassis Dynamic Brake kit is sized to a 1397 drive as detailed below.

Catalog Number	240VAC DB Rating		500VAC DB Rating	
	HP	(kW)	HP	(kW)
1397-DB-A001L	1.5	(1.2)	—	—
1397-DB-A002L	2	(1.5)	—	—
1397-DB-A003L	3	(2.2)	—	—
1397-DB-B003L	—	—	3	(2.2)
1397-DB-A005L	5	(3.7)	—	—
1397-DB-B005L	—	—	5	(3.7)
1397-DB-A007L	7.5	(5.5)	—	—
1397-DB-B007L	—	—	7.5	(5.5)
1397-DB-A010L	10	(7.5)	—	—
1397-DB-B010L	—	—	10	(7.5)
1397-DB-A015L	15	(11)	—	—
1397-DB-B015L	—	—	15	(11)
1397-DB-A020L	20	(15)	—	—
1397-DB-B025L	—	—	20-25	(15-18.5)
1397-DB-A025L	25	(18.5)	—	—
1397-DB-A030L	30	(22)	—	—
1397-DB-B030L	—	—	30	(22)
1397-DB-A040L	40	(30)	—	—
1397-DB-B040L	—	—	40	(30)
1397-DB-A060L	50-60	(37-45)	—	—
1397-DB-B060L	—	—	50-60	(37-45)
1397-DB-A075L	75	(56)	—	—
1397-DB-B075L	—	—	75	(56)
1397-DB-A100L	100	(75)	—	—
1397-DB-B100L	—	—	100-125	(75-93)
1397-DB-A125L	125	(93)	—	—
1397-DB-A150L	150	(112)	—	—
1397-DB-B150L	—	—	150	(112)
1397-DB-B200L	—	—	200	(149)
1397-DB-B250L	—	—	250	(187)
1397-DB-B300L	—	—	300	(224)
1397-DB-B400L	—	—	400	(298)
1397-DB-B500L	—	—	500	(373)
1397-DB-B600L	—	—	600	(448)

What These Instructions Contain

These instructions and any accompanying instructions contain the necessary information to assemble & install an Open Chassis 1397 Dynamic Brake. Each kit may be used with one or more of the 1397 drive HP ratings described on the previous page. For additional information on wire recommendations, brake parameters and related function blocks, refer to the 1397 User Manual.

Specifications

Duty Cycle	(3) repetitive stops with an average of (1) stop every (10) minutes.
Input Power	DC Power Supplied from 1397 Drive for all ratings. For 1.5-300HP drive ratings, 120V AC customer supplied power required for separate DB contactor operation. For 400-600HP drive ratings, DB uses drive contactor.
Enclosure Type	IP00 (Open).
Altitude Derating	1,000 meters (3,300 feet) maximum without derating.
Mounting Requirements	For 1397-DB-A001L-A150L and 1397-B003L-B300L kits, DB contactor must be mounted in the vertical position. For 1397-DB-B400L-B600L kits, DB uses drive contactor. All other DB components may be mounted as required.

Installation



ATTENTION: Electric Shock can cause injury or death. Remove all power before working on this product.

The drive is at line voltage when connected to incoming AC power. Before proceeding with any installation or troubleshooting activity, disconnect, lockout and tag all incoming power to the drive. Verify with a voltmeter that no voltage exists at terminals L1, L2 and L3 on the drive input power terminal block.



ATTENTION: Dynamic braking resistors may be extremely hot. Install in an enclosure or provide adequate clearance to ensure that nothing can come in direct contact with, or in proximity to the DB resistors. Failure to observe this precaution can result in severe burns and damage to, or destruction of, the equipment.

IMPORTANT: The National Electrical Code (NEC) and local regulations govern the installation and wiring of the dynamic brake. AC power wiring, DC power wiring, control wiring and conduit must be chosen and installed in accordance with these codes and the information supplied in the 1397 User Manual.

Selection

All Open Chassis Dynamic Brake kits include a resistor assembly and an open cage resistor enclosure. Each resistor assembly consists of a backplate with one or more pairs of resistors mounted in a series or in a series/parallel configuration.

Dynamic brake kits 1397-DB-A001L — A150L and 1397-DB-B003L — B300L include a DB contactor with (1) contactor suppressor that mounts across the contactor coil.

Dynamic brake kits 1397-DB-B400L — B600L use the drive contactor.

What This Option Provides

The DB contactors listed for the following kits require a 120V AC power supply that will meet the specified continuous and inrush VA values listed below. To guard against shock hazard, either the open cage enclosure or an equivalent enclosure must be used to enclose both the backplate and contactor.

240VDC DB Catalog No.	Resistor Assembly			Contactor				
	Assembly PN	Resistor PN	Description	PN	Drive HP/Voltage	Motor Armature Amps/Voltage	VA _{INRUSH}	VA _{HOLD}
1397-DB-A001L	800160-20P	48267-P	(1) Resistor	705310-100A	1.5HP/230V AC	7A/240VDC	80	10
1397-DB-A002L	800160-20R	48267-J	(2) Series Connected Resistors		2HP/230V AC	9A/240VDC		
1397-DB-A003L	800160-20S	48267-H	(2) Series Connected Resistors		3HP/230V AC	12A/240VDC		
1397-DB-A005L	800160-20T	48267-F	(2) Series Connected Resistors	705310-110A	5HP/230V AC	20A/240VDC	100	11
1397-DB-A007L	800160-20V	48267-D	(2) Series Connected Resistors		7.5HP/230V AC	29A/240VDC		
1397-DB-A010L	800160-20W	48267-C	(1) Resistor	705310-130A	10HP/230V AC	38A/240VDC	325	25
1397-DB-A015L	800160-20X	48267-A	(2) Series Connected Resistors		15HP/230V AC	55A/240VDC		
1397-DB-A020L	800160-20Y	48267-C	(4) Series/Parallel Connected Resistors		20HP/230V AC	73A/240VDC		
1397-DB-A025L	800160-20RB	48267-B	(4) Series/Parallel Connected Resistors	705310-140A	25HP/230V AC	93A/240VDC	325	25
1397-DB-A030L	800160-20RC	48267-A	(4) Series/Parallel Connected Resistors		30HP/230V AC	110A/240VDC		
1397-DB-A040L	800160-20RD	402422-3F	(2) Series Connected Resistors	705310-150A	40HP/230V AC	146A/240VDC	900	55
1397-DB-A060L	800160-20RE	402422-3G	(2) Series Connected Resistors		50HP/230V AC	180A/240VDC		
					60HP/230V AC	218A/240VDC		
1397-DB-A075L	800160-20RF	402422-3K	(2) Series Connected Resistors	705310-160A	75HP/230V AC	265A/240VDC	900	55
1397-DB-A100L	800160-20RG	402422-3L	(2) Series Connected Resistors	705310-170A	100HP/230V AC	360A/240VDC	1200	70
1397-DB-A125L	800160-20RH	402422-3P	(3) Series Connected Resistors	705310-180A	125HP/230V AC	434A/240VDC	2900	105
1397-DB-A150L	800160-20RJ	402422-3Q	(3) Series Connected Resistors		150HP/230V AC	521A/240VDC		

500VDC DB Catalog No.	Resistor Assembly			Contactor				
	Assembly PN	Resistor PN	Description	PN	Drive HP/Voltage	Motor Armature Amps/Voltage	VA _{INRUSH}	VA _{HOLD}
1397-DB-B003L	800160-20SP	48267-N	(3) Series Connected Resistors	705310-100A	3HP/460V AC	6A/500VDC	80	10
1397-DB-B005L	800160-20SR	48267-K	(3) Series Connected Resistors		5HP/460V AC	10A/500VDC		
1397-DB-B007L	800160-20SS	48267-J	(3) Series Connected Resistors		7.5HP/460V AC	14A/500VDC		
1397-DB-B010L	800160-20ST	48267-H	(3) Series Connected Resistors	705310-110A	10HP/460V AC	19A/500VDC	100	11
1397-DB-B015L	800160-20SV	48267-F	(3) Series Connected Resistors		15HP/460V AC	27A/500VDC		
1397-DB-B020L	800160-20SW	48267-C	(4) Series Connected Resistors	705310-130A	20HP/460V AC	35A/500VDC	325	25
1397-DB-B025L					25HP/460V AC	45A/500VDC		
1397-DB-B030L	800160-20SX	48267-B	(4) Series Connected Resistors		30HP/460V AC	52A/500VDC		
1397-DB-B040L	800160-20SY	48267-A	(4) Series Connected Resistors		40HP/460V AC	73A/500VDC		
1397-DB-B060L	800160-20SB	402422-3D	(3) Series Connected Resistors	705310-140A	50HP/460V AC	86A/500VDC	325	25
					60HP/460V AC	100A/500VDC		
1397-DB-B075L	800160-20SC	402422-3E	(3) Series Connected Resistors	705310-150A	75HP/460V AC	129A/500VDC	900	55
1397-DB-B100L	800160-20SD	402422-3F	(3) Series Connected Resistors		100HP/460V AC	167A/500VDC		
1397-DB-B125L					125HP/460V AC	207A/500VDC		
1397-DB-B150L	800160-20SE	402422-3J	(4) Series Connected Resistors	705310-160A	150HP/460V AC	250A/500VDC	900	55
1397-DB-B200L	800160-20SF	402422-3K	(4) Series Connected Resistors	705310-170A	200HP/460V AC	330A/500VDC	1200	70
1397-DB-B250L	802272-53R	402422-7Z	(2) Series Connected Resistors	705310-180A	250HP/460V AC	412A/500VDC	2900	105
1397-DB-B300L	802272-53S	402422-7AD	(2) Series Connected Resistors		300HP/460V AC	495A/500VDC		
1397-DB-B400L	802272-53T	402422-7AH	(2) Series Connected Resistors	Not Applicable				
1397-DB-B500L	802272-53V	402422-7AL	(2) Series Connected Resistors					
1397-DB-B600L	802272-53W	402422-7AN	(2) Series Connected Resistors					

Resistor Assembly Dimensions

Side — Single Resistor — Cat. No. 1397-DB-A001L

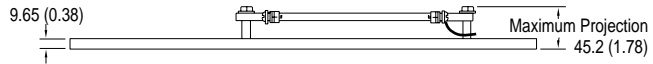

Side — Two/Four Resistors — Cat. Nos. 1397-DB-A002L - A150L

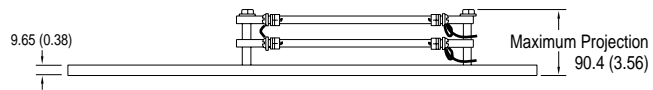

Side — Three/Four Resistors — Cat. Nos. 1397-DB-B003L - B040L

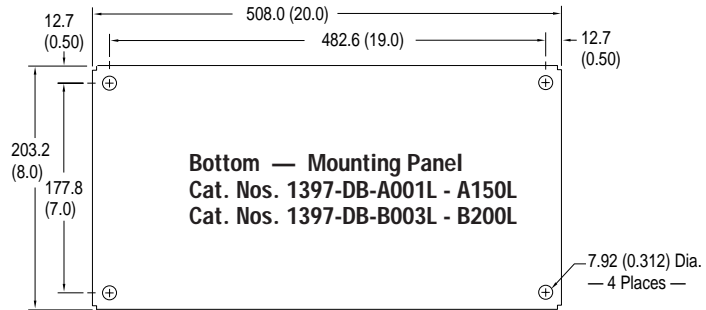
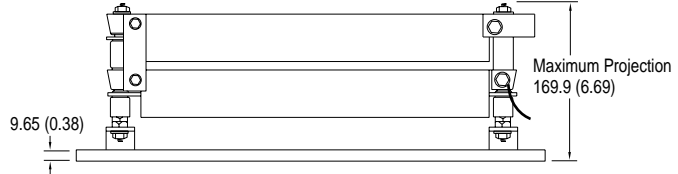

Side — Two Resistors — Cat. Nos. 1397-DB-B250L - B600L

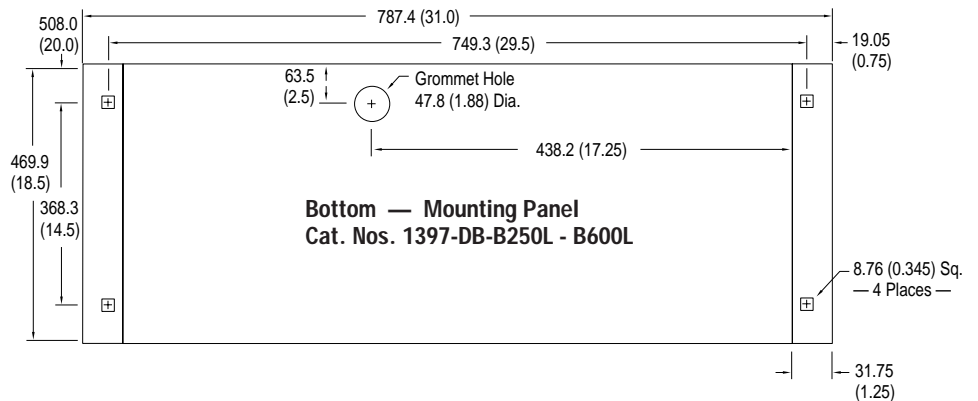
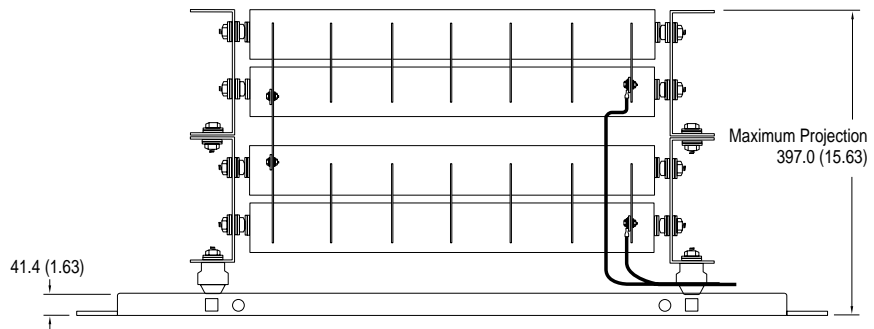

All Dimensions in Millimeters and (Inches)

Contactors Dimensions

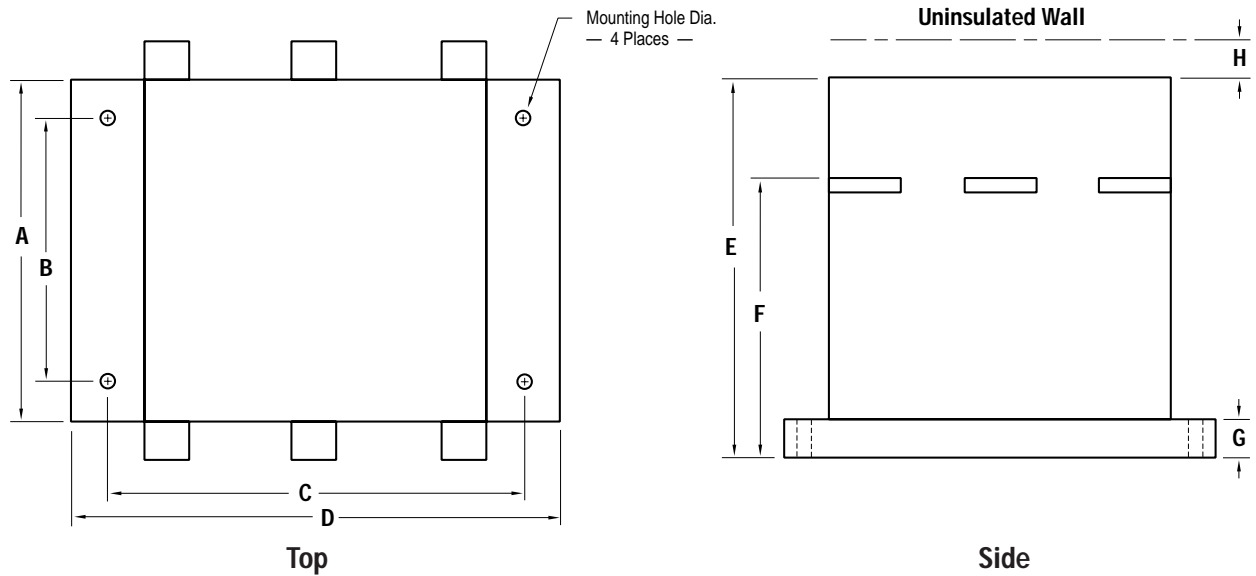

Contactor Dimensions — All Dimensions in Millimeters and (Inches)									
PN	A	B	C	D	E	F	G	H	Mounting Hole Dia.
705310-100A	69.1 (2.72)	59.9 (2.36)	35.0 (1.38)	43.9 (1.73)	118.9 (4.68)	76.0 (3.00)	0.35 (8.89)	—	4.5 (0.18)
705310-110A	81.0 (3.19)	69.4 (2.74)	45.0 (1.78)	54.0 (2.13)	121.5 (4.79)	80.0 (3.15)	8.9 (0.35)	—	4.5 (0.18)
705310-130A	130.0 (5.12)	100.0 (3.94)	90.0 (3.55)	102.0 (4.02)	137.0 (5.40)	95.0 (3.75)	21.5 (0.85)	30.0 (1.19)	5.7 (0.23)
705310-140A	130.0 (5.12)	100.0 (3.94)	90.0 (3.55)	102.0 (4.02)	137.0 (5.40)	95.0 (3.75)	21.5 (0.85)	30 (1.19)	5.7 (0.23)
705310-150A	198.0 (7.80)	140.0 (5.52)	120.0 (4.73)	136.0 (5.36)	168.0 (6.62)	103.0 (4.1)	10.5 (0.42)	15.0 (0.60)	6.8 (0.27)
705310-160A	198.0 (7.80)	140.0 (5.52)	120.0 (4.73)	136.0 (5.36)	168.0 (6.62)	103.0 (4.1)	10.5 (0.42)	15.0 (0.60)	6.8 (0.27)
705310-170A	207 (8.2)	140 (5.52)	160 (6.3)	182 (7.17)	178 (7.01)	107 (4.22)	19 (0.75)	30 (1.20)	6.8 (0.27)
705310-180A	272 (10.71)	200 (7.88)	170 (6.7)	198 (7.8)	226 (8.9)	140 (5.52)	23 (0.91)	45 (1.78)	6.8 (0.27)

Open Cage Resistor Enclosure Dimensions

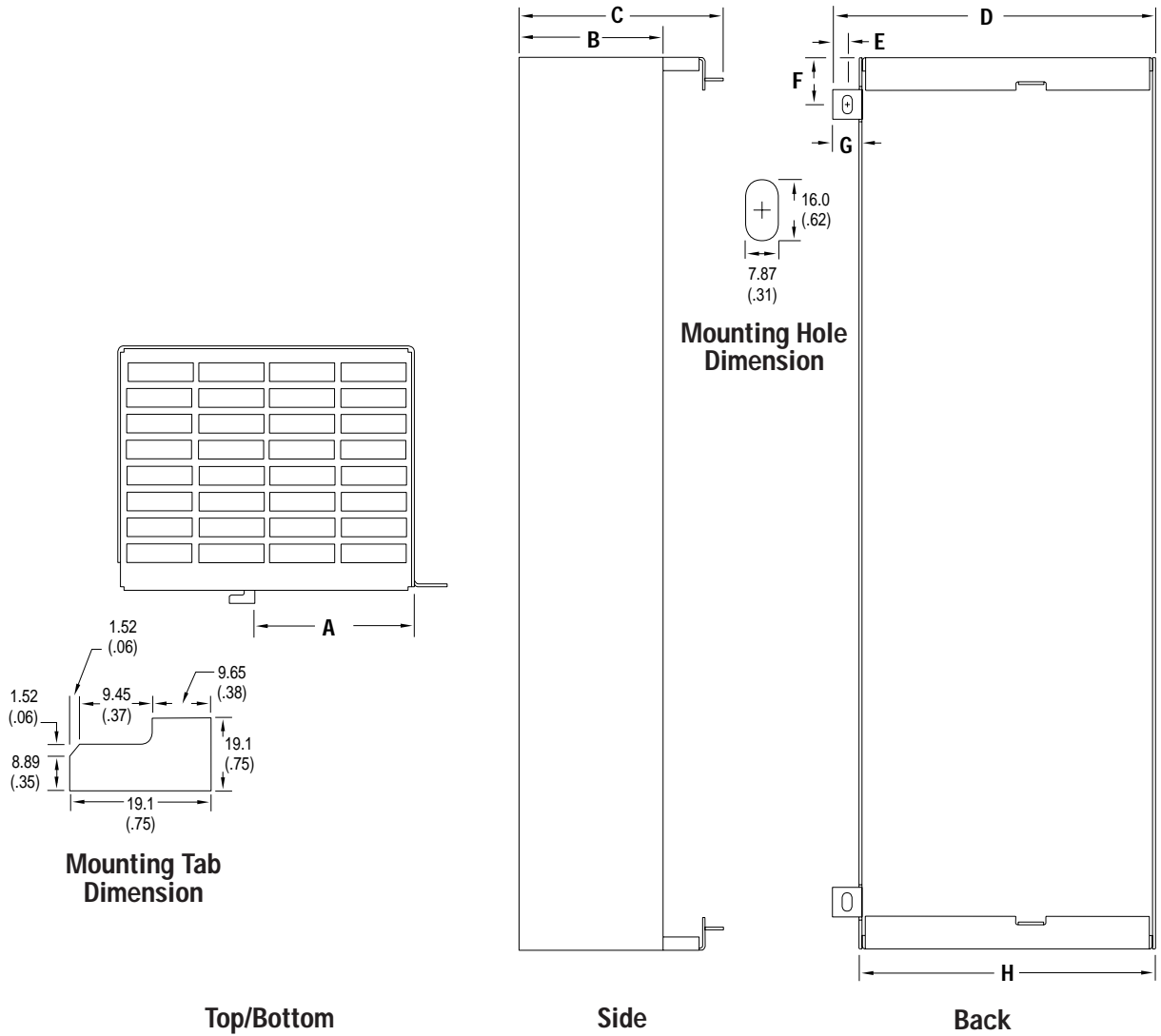

Open Cage Resistor Enclosure Dimensions — All Dimensions in Millimeters and (Inches)									
Drive Cat. Nos.	PN	A	B	C	D	E	F	G	H
1397-DB-A001L - A150L	800798-54R	131.8	142.8	187.5	266.7	25.4	46.0	25.4	241.30
1397-DB-B003L - B200L		(5.19)	(5.62)	(7.38)	(10.50)	(1.00)	(1.81)	(1.00)	(9.50)

Open Cage Resistor Enclosure Dimensions

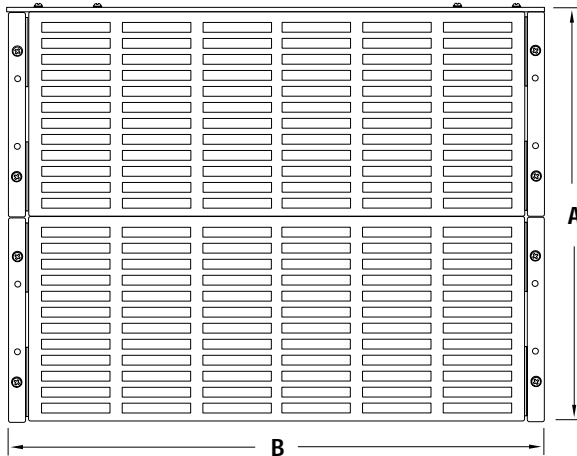

Side

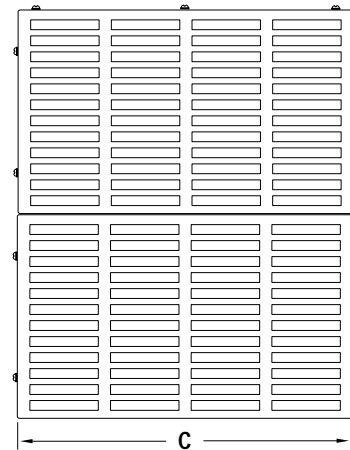

End

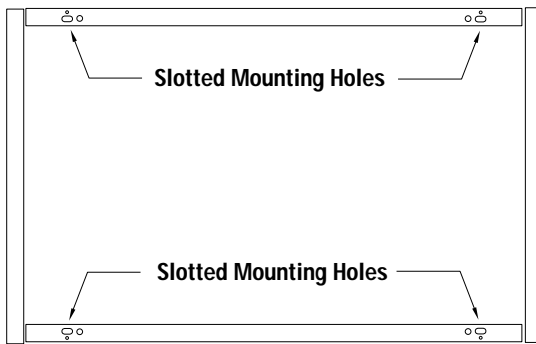

Bottom

Approximate Open Cage Resistor Enclosure Dimensions — All Dimensions in Millimeters and (Inches)				
Drive Cat. Nos.	PN	A	B	C
1397-DB-B 250L -B600L	802272-52S	454.0 (17.9)	752.5 (29.6)	468.3 (18.4)

1397-DB-A001L — A150L B003L — B300L Dynamic Brake Kit Operation

Dynamic braking slows down a rotating DC motor and its load. It is an uncontrolled process. During dynamic braking, the motor armature is disconnected from the drive. A resistor is placed across the motor's rotating armature (now acting as a generator), and the resulting current causes braking torque in the motor. The motor will decelerate, even with a drive malfunction, as long as motor shunt field excitation is maintained.

The drive must have the DC contactor open for dynamic braking to occur. Dynamic Braking is typically initiated with a Coast/DB stop command or a drive fault. Under drive fault conditions, the DC contactor opens and applies the dynamic braking grid across the armature for a dynamic braking stop.

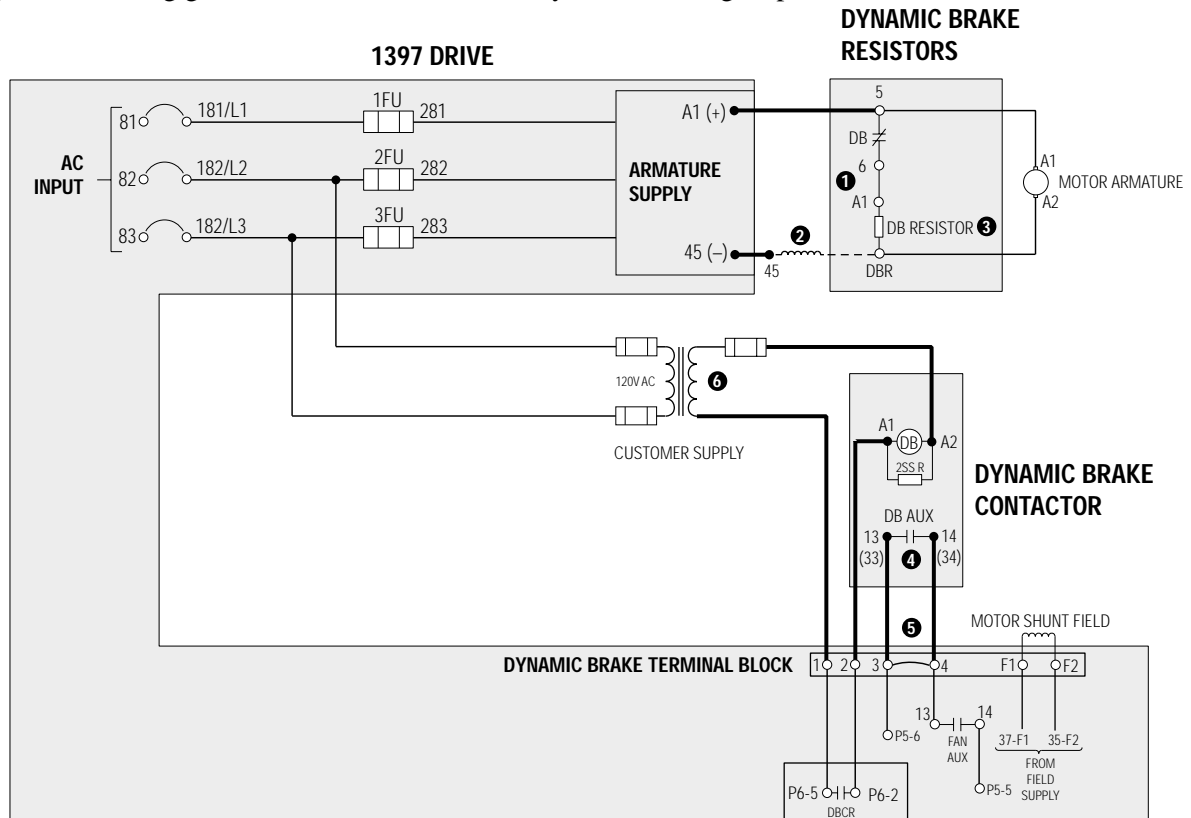

1397-DB-A001L — A150L B003L — B300L

Wiring

Remove and lockout all power to the drive and follow the wiring diagram above.

- ❶ Connect user supplied leads between drive terminals A1 & 45 and DB resistor assembly terminals 3 & DBR.
- ❷ If the motor has a series field, connect the motor series leads between drive terminal 45 and DB resistor terminal DBR.
- ❸ Connect the suppressor included with the kit between DB contactor terminals A1 and A2 and place the label included with the kit near the contactor.
- ❹ Use auxiliary contacts 33 & 34 when available.
- ❺ Remove the jumper between terminals 3 & 4 at the drive terminal block and connect user supplied leads between drive terminals 2, 3 & 4 and DB contactor terminals A1, 13 & 14.
- ❻ Connect the user supplied 120V AC DB contactor power supply as shown.

Refer to 1397-DB-A001L — A150L/B003L — B300L Dynamic Brake Kit Operation above and proceed to Setup on the last page.

1397-DB-B400L — B600L Dynamic Brake Kit Operation

Dynamic braking slows down a rotating DC motor and its load. It is an uncontrolled process. During dynamic braking, the motor armature is disconnected from the drive. A resistor is placed across the motor's rotating armature (now acting as a generator), and the resulting current causes braking torque in the motor. The motor will decelerate, even with a drive malfunction, as long as motor shunt field excitation is maintained.

When the motor is running normally, the drive's normally-open M contacts are closed and the normally-closed M contact is open. When the drive is connected to the motor, the dynamic braking resistor assembly is disconnected.

For 1397-DB-B400L — B600L Kits
If You are Using the Basic Configuration . . .

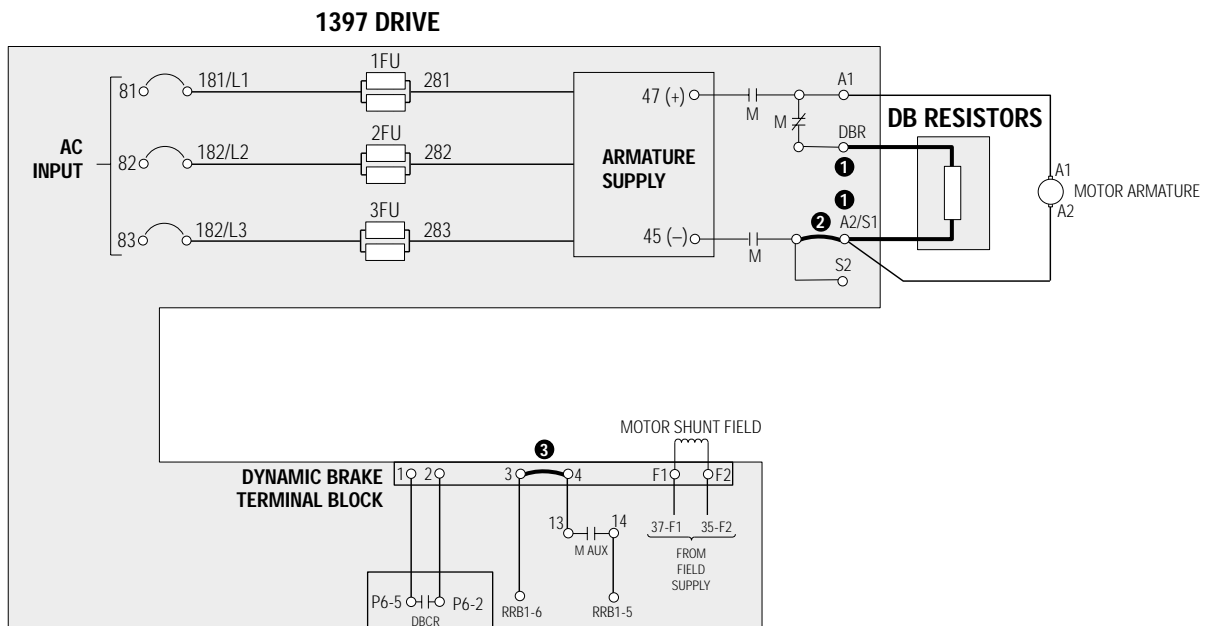

Remove and lockout all power to the drive and follow the wiring diagram above.

- ❶ Route the DB resistor cables through the grommets in the resistor mounting panel. Connect to connection bars DBR & A2/S1 at the top of the 1397 drive using the (2) M10 hex bolts, washers and KEP nuts supplied with the kit. Torque to 23.00 N-m (200 lb.-in.).
- ❷ Verify that the removable connector bar link at A2/S1 is installed.
- ❸ Verify that the jumper between terminals 3 & 4 at the drive terminal block is installed.

Remove the lockout and reapply power. Refer to 1397-DB-B400L — B600L Dynamic Brake Kit Operation above and proceed to Setup on the last page.

For 1397-DB-B400L — B600L Kits If You are Using DB with an Inverting Fault Circuit Breaker . . .

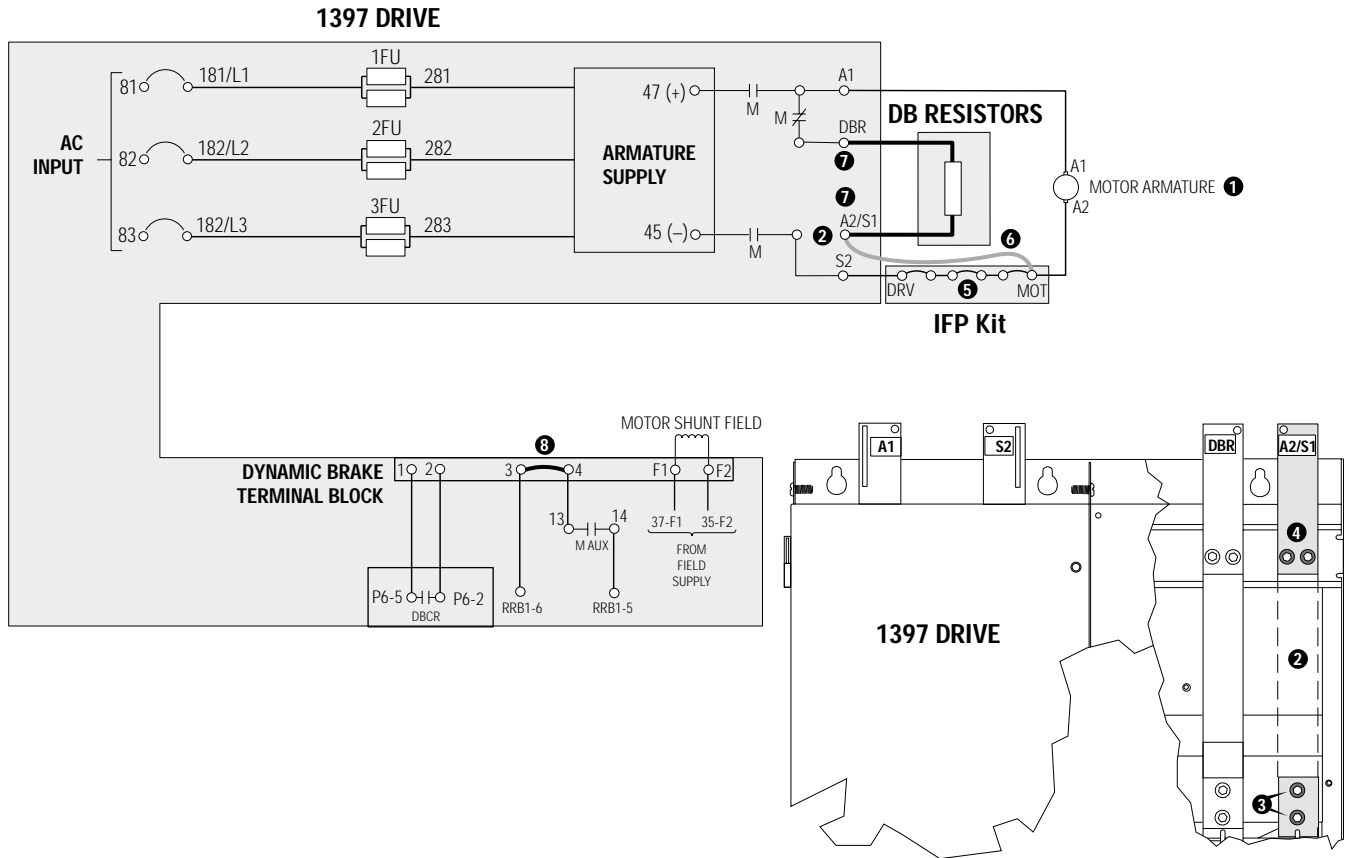

Remove and lockout all power to the drive and follow the wiring diagram above.

- ❶ Follow the wiring diagram above to connect the motor armature to the drive and Inverting Fault Circuit Breaker.
- ❷ Remove the connector bar link at A2/S1, but retain the A2/S1 connection bar and all (4) mounting bolts.
- ❸ Replace the (2) lower bar bolts removed previously. Torque to 23.00 N-m (200 lb.-in.).
- ❹ Replace the upper A2/S1 terminal bar using the (2) upper bar bolts removed previously. Torque to 23.00 N-m (200 lb.-in.).
- ❺ Connect the Inverting Fault Circuit Breaker kit to the DRV and MOT terminals as shown. Refer to the Inverting Fault Circuit Breaker Installation Instructions for additional information.
- ❻ Route customer supplied cable between A2/S1 and MOT. Cable should be sized to the same guage as the DB resistor cables.
- ❼ Route the DB resistor cables through the grommated hole in the resistor mounting panel. Connect to connection bars DBR & A2/S1 at the top of the 1397 drive using the (2) M10 hex bolts, washers and KEP nuts supplied with the kit. Torque to 23.00 N-m (200 lb.-in.).
- ❽ Verify that the jumper between terminals 3 & 4 at the drive terminal block is installed.

Remove the lockout and reapply power. Refer to 1397-DB-B400L — B600L Dynamic Brake Kit Operation above and proceed to Setup on the last page.

For 1397-DB-B400L — B600L Kits
 If You are Using DB with a Motor Series Field
 — S1 connected to A2 — with an Inverting Fault Circuit Breaker . . .

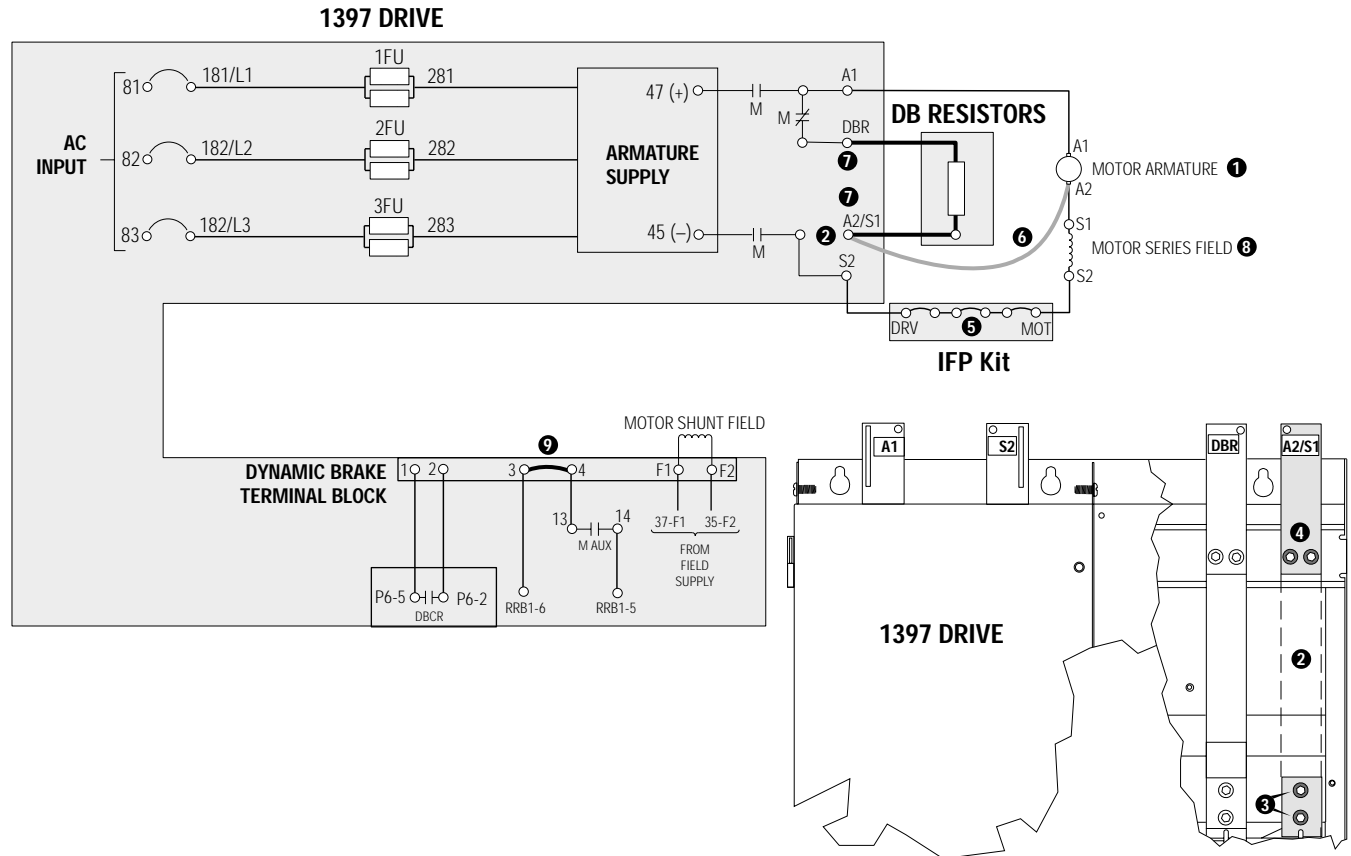

Remove and lockout all power to the drive and follow the wiring diagram above.

- ❶ Follow the wiring diagram above to connect the motor armature to the drive and Inverting Fault Circuit Breaker.
- ❷ Remove the connector bar link at A2/S1, but retain the A2/S1 connection bar and all (4) mounting bolts.
- ❸ Replace the (2) lower bar bolts removed previously. Torque to 23.00 N-m (200 lb.-in.).
- ❹ Replace the upper A2/S1 terminal bar using the (2) upper bar bolts removed previously. Torque to 23.00 N-m (200 lb.-in.).
- ❺ Connect the Inverting Fault Circuit Breaker kit to the DRV and MOT terminals as shown. Refer to the Inverting Fault Circuit Breaker Installation Instructions for additional information.
- ❻ Route customer supplied cable between A2/S1 and motor connection A2 or S1. Cable should be sized to the same guage as the DB resistor cables.
- ❼ Route the DB resistor cables through the grommated hole in the resistor mounting panel. Connect to connection bars DBR & A2/S1 at the top of the 1397 drive using the (2) M10 hex bolts, washers and KEP nuts supplied with the kit. Torque to 23.00 N-m (200 lb.-in.).
- ❽ Connect the motor series field between S1 & S2.
- ❾ Verify that the jumper between terminals 3 & 4 at the drive terminal block is installed.

Remove the lockout and reapply power. Refer to 1397-DB-B400L — B600L Dynamic Brake Kit Operation above and proceed to Setup on the last page.

For 1397-DB-B400L — B600L Kits
 If You are Using DB with a Motor Series Field
 — S1 connected to A2 — without an Inverting Fault Circuit Breaker . . .

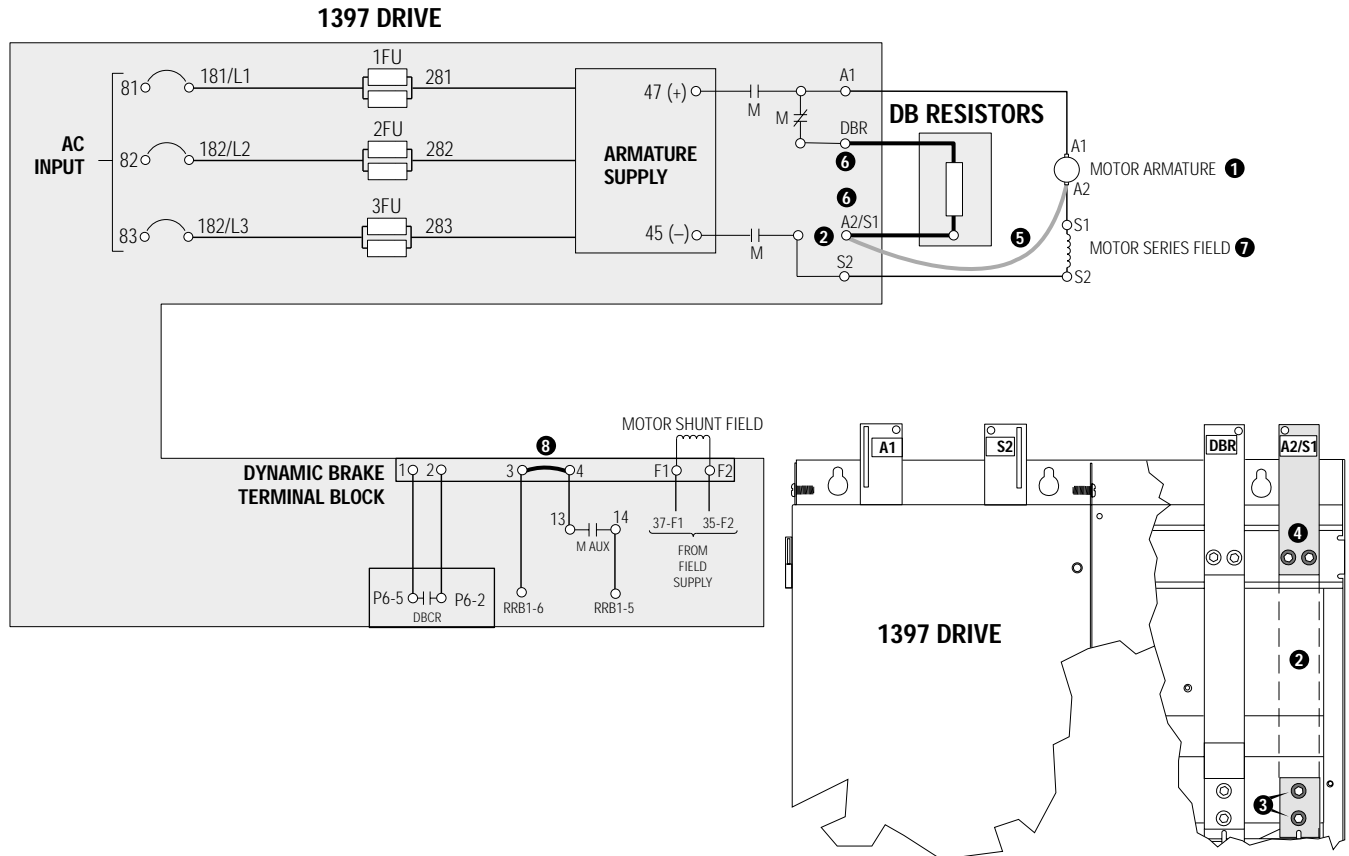

Remove and lockout all power to the drive and follow the wiring diagram above.

- ❶ Follow the wiring diagram above to connect the motor armature to the drive and Inverting Fault Circuit Breaker.
- ❷ Remove the connector bar link at A2/S1, but retain the A2/S1 connection bar and all (4) mounting bolts.
- ❸ Replace the (2) lower bar bolts removed previously. Torque to 23.00 N-m (200 lb.-in.).
- ❹ Replace the upper A2/S1 terminal bar using the (2) upper bar bolts removed previously. Torque to 23.00 N-m (200 lb.-in.).
- ❺ Route customer supplied cable between A2/S1 and motor connection A2 or S1. Cable should be sized to the same guage as the DB resistor cables.
- ❻ Route the DB resistor cables through the grommeted hole in the resistor mounting panel. Connect to connection bars DBR & A2/S1 at the top of the 1397 drive using the (2) M10 hex bolts, washers and KEP nuts supplied with the kit. Torque to 23.00 N-m (200 lb.-in.).
- ❼ Connect the motor series field between S1 & S2.
- ❽ Verify that the jumper between terminals 3 & 4 at the drive terminal block is installed.

Remove the lockout and reapply power. Refer to 1397-DB-B400L — B600L Dynamic Brake Kit Operation above and proceed to Setup on the last page.

For 1397-DB-B400L — B600L Kits
 If You are Using DB with a Motor Series Field
 — S1 connected to A2/S1 — with an Inverting Fault Circuit Breaker . . .

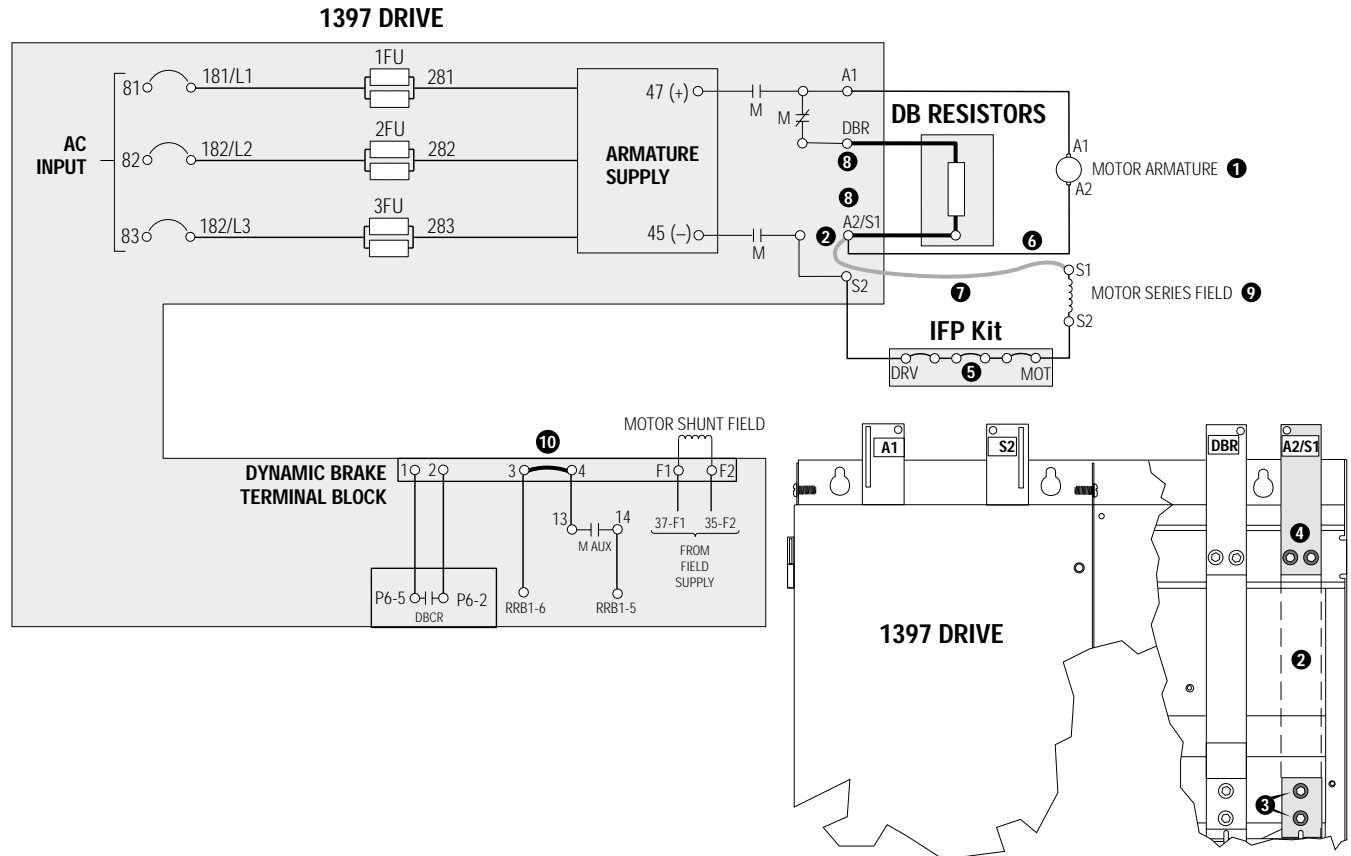

Remove and lockout all power to the drive and follow the wiring diagram above.

- ❶ Follow the wiring diagram above to connect the motor armature to the drive and Inverting Fault Circuit Breaker.
- ❷ Remove the connector bar link at A2/S1, but retain the A2/S1 connection bar and all (4) mounting bolts.
- ❸ Replace the (2) lower bar bolts removed previously. Torque to 23.00 N-m (200 lb.-in.).
- ❹ Replace the upper A2/S1 terminal bar using the (2) upper bar bolts removed previously. Torque to 23.00 N-m (200 lb.-in.).
- ❺ Connect the Inverting Fault Circuit Breaker kit to the DRV and MOT terminals as shown. Refer to the Inverting Fault Circuit Breaker Installation Instructions for additional information.
- ❻ Route and connect the A2 motor cable to drive connection bar A2/S1.
- ❼ Route customer supplied cable between A2/S1 and motor connection S1. Cable should be sized to the same gauge as the DB resistor cables.
- ❽ Route the DB resistor cables through the grommeted hole in the resistor mounting panel. Connect to connection bars DBR & A2/S1 at the top of the 1397 drive using the (2) M10 hex bolts, washers and KEP nuts supplied with the kit. Torque to 23.00 N-m (200 lb.-in.).
- ❾ Connect the motor series field between S1 & S2.
- ❿ Verify that the jumper between terminals 3 & 4 at the drive terminal block is installed.

Remove the lockout and reapply power. Refer to 1397-DB-B400L — B600L Dynamic Brake Kit Operation above and proceed to Setup on the last page.

For 1397-DB-B400L — B600L Kits
 If You are Using DB with a Motor Series Field
 — S1 connected to A2/S1 — without an Inverting Fault Circuit Breaker . . .

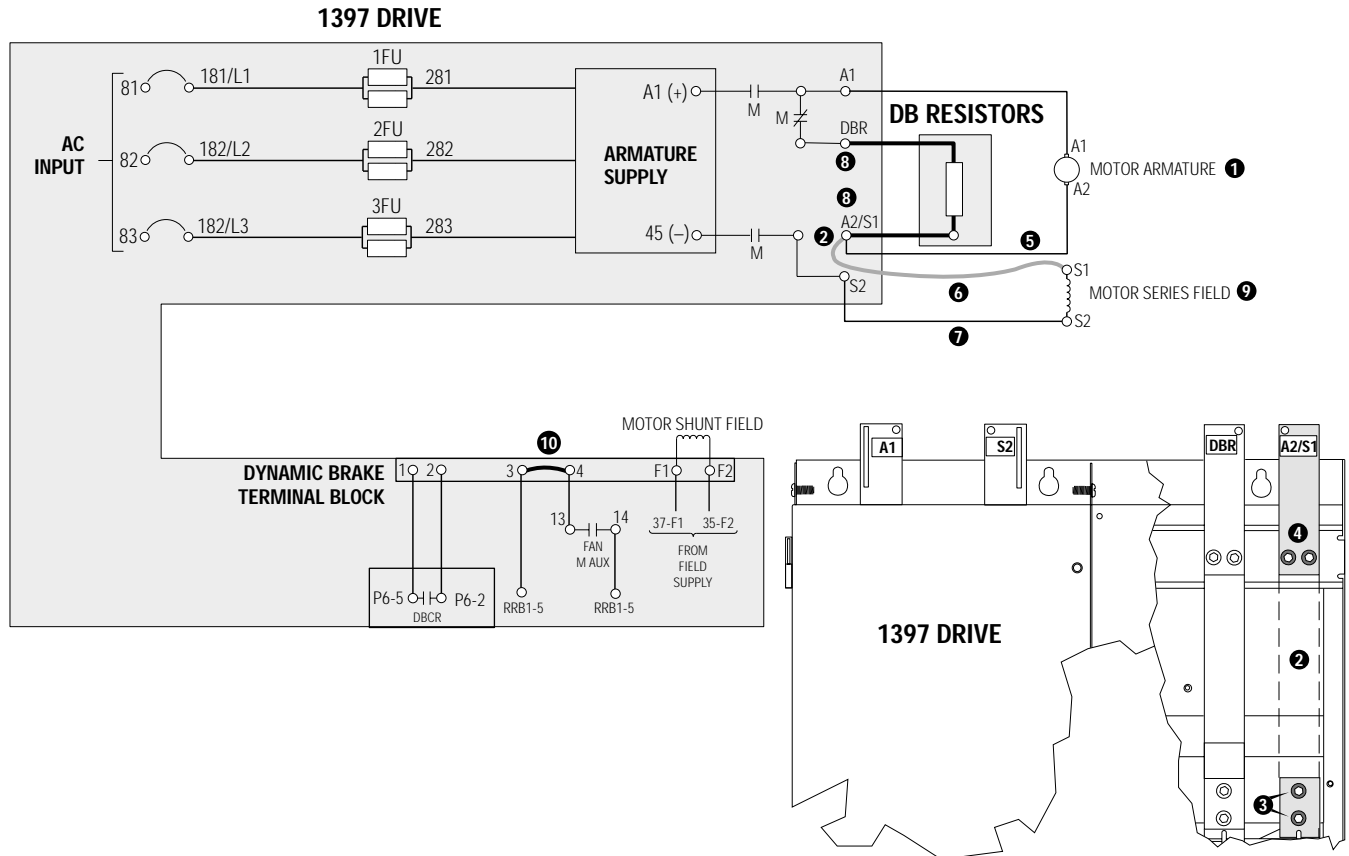

Remove and lockout all power to the drive and follow the wiring diagram above.

- ❶ Follow the wiring diagram above to connect the motor armature to the drive and Inverting Fault Circuit Breaker.
- ❷ Remove the connector bar link at A2/S1, but retain the A2/S1 connection bar and all (4) mounting bolts.
- ❸ Replace the (2) lower bar bolts removed previously. Torque to 23.00 N-m (200 lb.-in.).
- ❹ Replace the upper A2/S1 terminal bar using the (2) upper bar bolts removed previously. Torque to 23.00 N-m (200 lb.-in.).
- ❺ Route and connect the A2 motor cable to drive connection bar A2/S1.
- ❻ Route customer supplied cable between A2/S1 and motor connection S1. Cable should be sized to the same gauge as the DB resistor cables.
- ❼ Route and connect the S2 motor cable to drive connection S2.
- ❽ Route the DB resistor cables through the grommeted hole in the resistor mounting panel. Connect to connection bars DBR & A2/S1 at the top of the 1397 drive using the (2) M10 hex bolts, washers and KEP nuts supplied with the kit. Torque to 23.00 N-m (200 lb.-in.).
- ❾ Connect the motor series field between S1 & S2.
- ❿ Verify that the jumper between terminals 3 & 4 at the drive terminal block is installed.

Remove the lockout and reapply power. Refer to 1397-DB-B400L — B600L Dynamic Brake Kit Operation above and proceed to Setup on the last page.

Setup

Important: Depending upon the application, additional parameter adjustments may be required. If additional options are installed, different parameter settings may be required. Perform the Start-Up and Adjustment procedure in the 1397 User Manual to verify all parameter settings

Stop Mode

P.115 [Stop Mode Type]

Reset to 2 Coast/DB for dynamic braking.



Rockwell Automation helps its customers receive a superior return on their investment by bringing together leading brands in industrial automation, creating a broad spectrum of easy-to-integrate products. These are supported by local technical resources available worldwide, a global network of system solutions providers, and the advanced technology resources of Rockwell.

Worldwide representation.



Argentina • Australia • Austria • Bahrain • Belgium • Bolivia • Brazil • Bulgaria • Canada • Chile • China, People's Republic of • Colombia • Costa Rica • Croatia • Cyprus • Czech Republic • Denmark • Dominican Republic • Ecuador • Egypt • El Salvador • Finland • France • Germany • Ghana • Greece • Guatemala • Honduras • Hong Kong • Hungary • Iceland • India • Indonesia • Iran • Ireland • Israel • Italy • Jamaica • Japan • Jordan • Korea • Kuwait • Lebanon • Macau • Malaysia • Malta • Mexico • Morocco • The Netherlands • New Zealand • Nigeria • Norway • Oman • Pakistan • Panama • Peru • Philippines • Poland • Portugal • Puerto Rico • Qatar • Romania • Russia • Saudi Arabia • Singapore • Slovakia • Slovenia • South Africa, Republic of • Spain • Sweden • Switzerland • Taiwan • Thailand • Trinidad • Tunisia • Turkey • United Arab Emirates • United Kingdom • United States • Uruguay • Venezuela

Rockwell Automation Headquarters, 1201 South Second Street, Milwaukee, WI 53204-2496 USA, Tel: (1) 414 382-2000, Fax: (1) 414 382-4444