

## Allen-Bradley 1397 115VAC Control Interface Card Cat. No. 1397-L10

### Table of Contents

<b>What This Option Provides</b> . . . . .	1
<b>Where This Option Is Used</b> . . . . .	1
<b>What These Instructions Contain</b> . . . . .	1
<b>Specifications</b> . . . . .	2
<b>Wiring</b> . . . . .	3
<b>Installation</b> . . . . .	4
<b>Mounting Dimensions</b> . . . . .	5
<b>Setup</b> . . . . .	6

### What This Option Provides

The 115VAC Control Interface Card is a remote mounted option that provides a means of interfacing signals and commands to the 1397 drive using 115VAC signals. A 115VAC power source must be supplied by the user for the card to operate.

(12) 24VDC output terminals are provided on the card. A plug in DC cable assembly included with the kit allows direct remote connection to the Regulator Board terminal strip in the drive.

A plug in (14) input terminal strip is provided on the card to aid in making field connections. Each of the 115VAC input terminals is defined as either a command input signal or 115VAC.

### Where This Option Is Used

This option may be used with all 1397 drives.

### What These Instructions Contain

These instructions contain the necessary information to install a 1397 115VAC Control Interface Card. For additional information on signal requirements, wire recommendations and drive settings, refer to the 1397 User Manual — Publication 1397-5.0.

## Specifications

Circuits used with the 115VAC Interface Card must be cable of operating with high = true logic. In the low state, circuits must generate a voltage of no more than 50VAC. Leakage current must be 2.5-5 mA into a 10k $\Omega$ /3W load. In the high state, circuits must generate a voltage of 65-140VAC and source a current of approximately 12mA for each input.

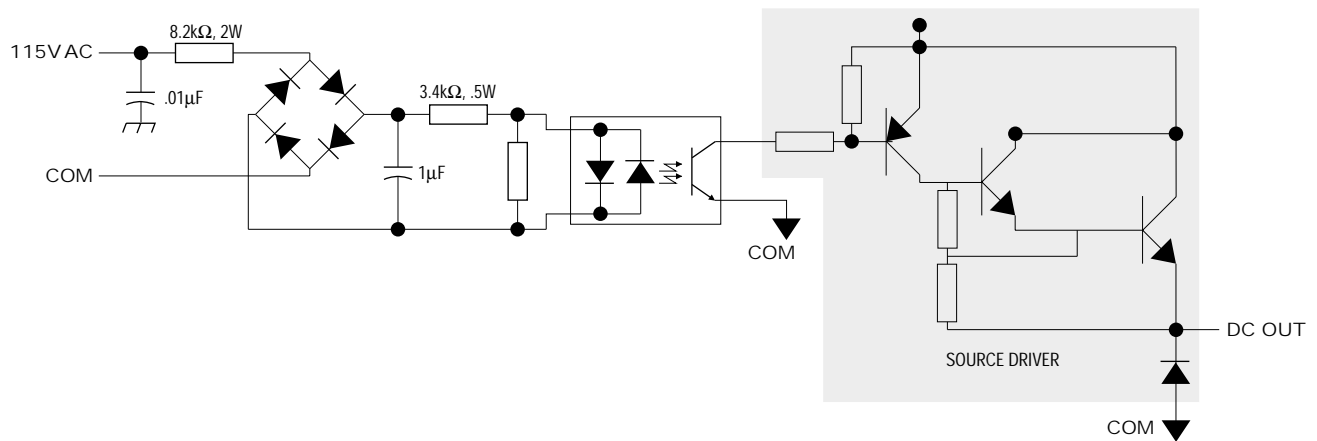

Typical 115VAC Control Interface Card I/O Circuit

<b>Card Dimensions</b>	Height:	224.8mm (8.85 in.)
	Width:	88.9mm (3.50 in.)
	Depth:	38.1mm (1.5 in.) Including Mounting Standoff
<b>Input Circuit</b>	Number of Command Inputs:	10
	Operating Voltage:	140VAC Max./120VAC Nominal
	Turn-On Voltage:	65VAC Min.
	Turn-Off Voltage:	50VAC Max.
	Input Current:	12mA per Input at 120VAC
	Total Input Current:	120mA Max. at 120VAC
	Turn-On Delay:	8.0mS Max.
	Turn-Off Delay:	2.0mS Max.
Ground:	Inputs Have Common Ground	
<b>Output Circuit</b>	Number of Command Outputs:	10
	Operating Voltage:	35VDC Max./24VDC Nominal
	Max. Current:	500mA Single Channel 3A All Channels
	Max. Leakage Current:	0.1 mA
	Max. ON State Voltage Drop:	2V
	Ground:	Outputs Have Common Ground

# Wiring



**ATTENTION:** Electric Shock can cause injury or death. Remove all power before working on this product.

The drive is at line voltage when connected to incoming AC power. Before proceeding with any installation or troubleshooting activity, disconnect, lockout and tag all incoming power to the drive. Verify with a voltmeter that no voltage exists at terminals L1, L2 and L3 on the drive input power terminal block.

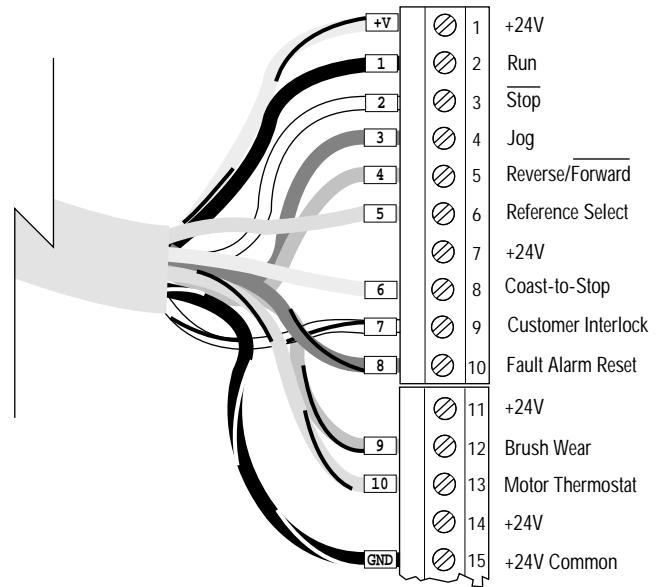

Regulator Board Terminal Strip

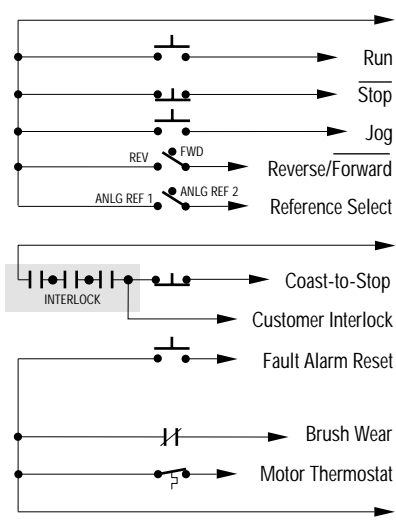
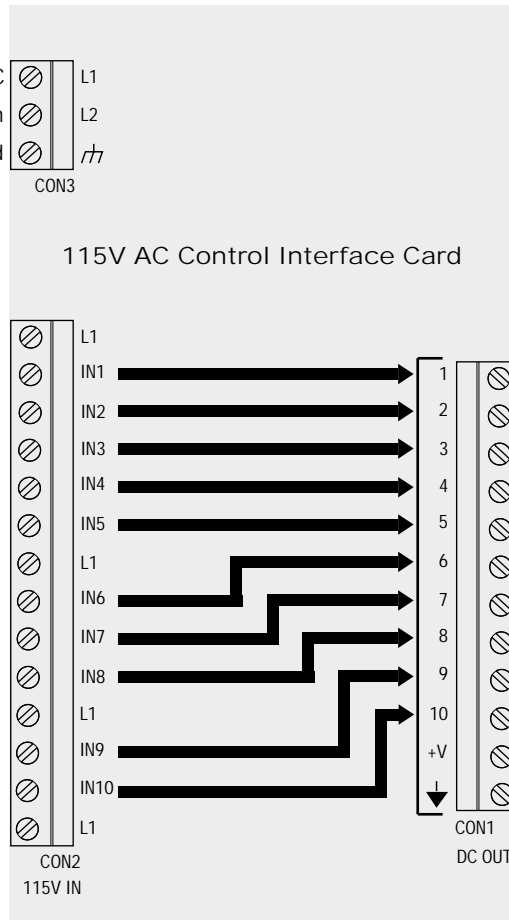
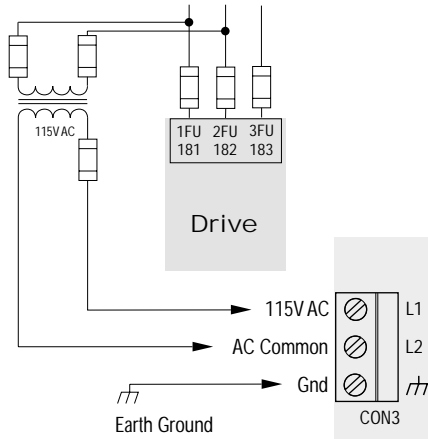

## Installation



**ATTENTION:** This board contains ESD (Electrostatic Discharge) sensitive parts and assemblies. Static control precautions are required when installing, testing, servicing or repairing this assembly. Component damage may result if ESD control precautions are not followed. If you are not familiar with static control procedures, reference publication 8000-4.5.2, "Guarding Against Electrostatic Damage" or any other applicable ESD protection handbook.

---

**IMPORTANT:** The National Electrical Codes (NEC) and local regulations govern the installation and wiring of the 115V AC Control Interface Card and enclosure selection. AC power wiring, control wiring and conduit must be chosen and installed in accordance with these codes and the information supplied in the 1397 User Manual — publication 1397-5.0.

**IMPORTANT:** If the 115V AC Control Interface Card will not be de-energized by opening the drive disconnect, attach the danger label included with the kit in a prominent location in the drive enclosure.

The 115V AC Control Interface Card is mounted within 1.22 m (48 In.) of the 1397 Drive Regulator Card using the pre-wired interconnection cable included with the kit. Use the (4) M4 × 80 Taptite screws and washers for card installation per the Mounting Dimensions on the following page.

### Mounting Dimensions

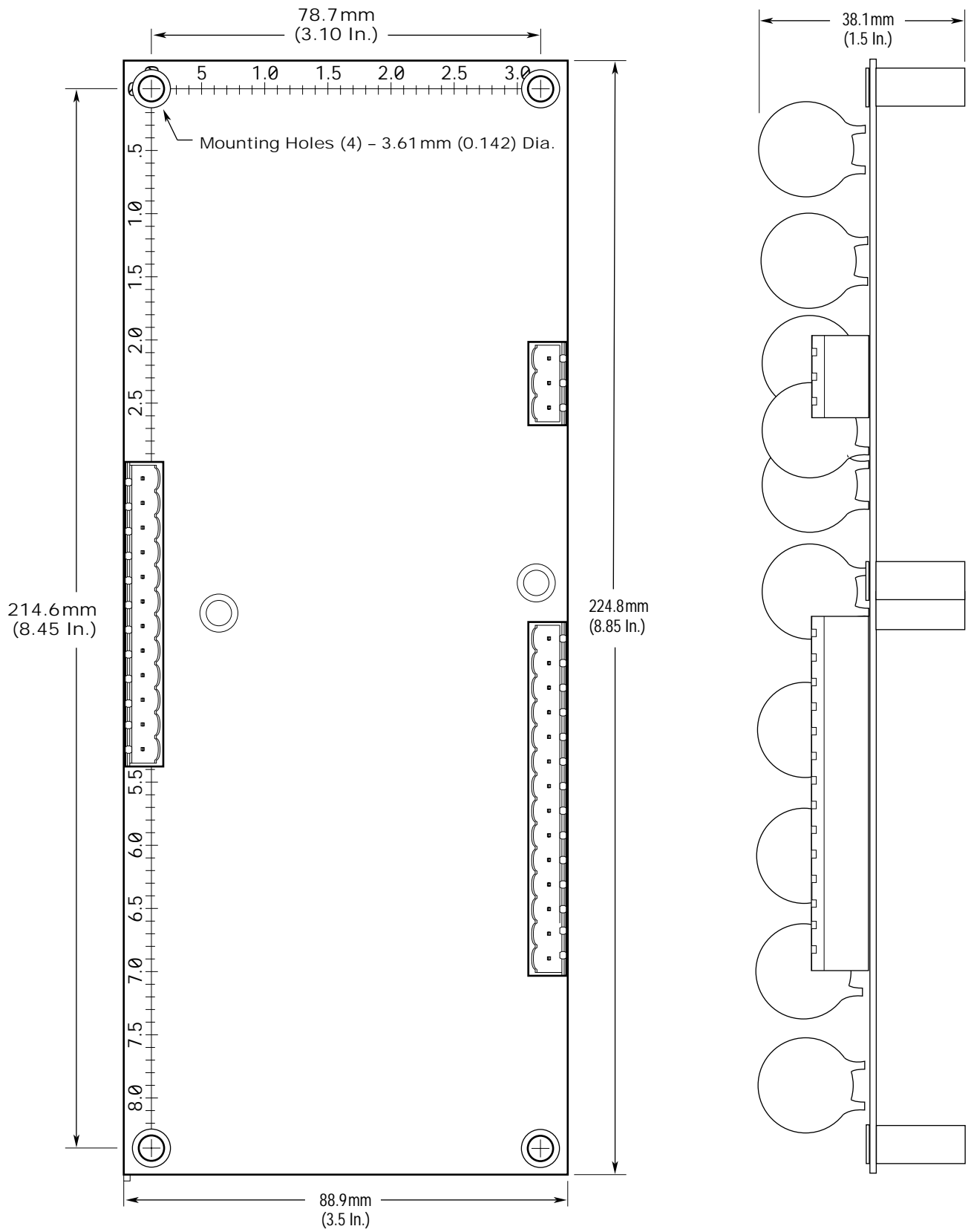

**Setup**

No software configuration or parameter changes are required to the drive when installing the 115VAC Control Interface Card.





Rockwell Automation helps its customers receive a superior return on their investment by bringing together leading brands in industrial automation, creating a broad spectrum of easy-to-integrate products. These are supported by local technical resources available worldwide, a global network of system solutions providers, and the advanced technology resources of Rockwell.

## Worldwide representation.



Argentina • Australia • Austria • Bahrain • Belgium • Bolivia • Brazil • Bulgaria • Canada • Chile • China, People's Republic of • Colombia • Costa Rica • Croatia • Cyprus • Czech Republic • Denmark • Dominican Republic • Ecuador • Egypt • El Salvador • Finland • France • Germany • Ghana • Greece • Guatemala • Honduras • Hong Kong • Hungary • Iceland • India • Indonesia • Iran • Ireland • Israel • Italy • Jamaica • Japan • Jordan • Korea • Kuwait • Lebanon • Macau • Malaysia • Malta • Mexico • Morocco • The Netherlands • New Zealand • Nigeria • Norway • Oman • Pakistan • Panama • Peru • Philippines • Poland • Portugal • Puerto Rico • Qatar • Romania • Russia • Saudi Arabia • Singapore • Slovakia • Slovenia • South Africa, Republic of • Spain • Sweden • Switzerland • Taiwan • Thailand • Trinidad • Tunisia • Turkey • United Arab Emirates • United Kingdom • United States • Uruguay • Venezuela

Rockwell Automation Headquarters, 1201 South Second Street, Milwaukee, WI 53204-2496 USA, Tel: (1) 414 382-2000, Fax: (1) 414 382-4444