



Allen-Bradley

PowerFlex[®]
Communications

EtherNet/IP Adapter

**22-COMM-E
FRN 1.xxx**

User Manual

**Rockwell
Automation**

Important User Information

Solid state equipment has operational characteristics differing from those of electromechanical equipment. “*Safety Guidelines for the Application, Installation and Maintenance of Solid State Controls*” (Publication SGI-1.1 available from your local Rockwell Automation Sales Office or online at <http://www.ab.com/manuals/gi>) describes some important differences between solid state equipment and hard-wired electromechanical devices. Because of this difference, and also because of the wide variety of uses for solid state equipment, all persons responsible for applying this equipment must satisfy themselves that each intended application of this equipment is acceptable.

In no event will Rockwell Automation, Inc. be responsible or liable for indirect or consequential damages resulting from the use or application of this equipment.

The examples and diagrams in this manual are included solely for illustrative purposes. Because of the many variables and requirements associated with any particular installation, Rockwell Automation, Inc. cannot assume responsibility or liability for actual use based on the examples and diagrams.

No patent liability is assumed by Rockwell Automation, Inc. with respect to use of information, circuits, equipment, or software described in this manual.

Reproduction of the contents of this manual, in whole or in part, without written permission of Rockwell Automation, Inc. is prohibited.

Throughout this manual we use notes to make you aware of safety considerations.



ATTENTION: Identifies information about practices or circumstances that can lead to personal injury or death, property damage, or economic loss.

Attentions help you:

- identify a hazard
- avoid the hazard
- recognize the consequences

Important: Identifies information that is especially important for successful application and understanding of the product.



Shock Hazard labels may be located on or inside the drive to alert people that dangerous voltage may be present.

ControlFLASH, DriveExplorer, DriveTools, DriveExecutive, PLC-5, SCANport, and SLC are trademarks of Rockwell Automation, Inc.

Allen-Bradley, PowerFlex, and ControlLogix are registered trademarks of Rockwell Automation, Inc.

RSLinx, RSLogix, and RSNetWorx are trademarks of Rockwell Software.

Ethernet is a trademark of Digital Equipment Corporation, Intel Corporation, and Xerox Corporation.

Netscape and Netscape Navigator are registered trademarks of the Netscape Communications Corporation.

Windows, Windows CE, Windows NT, and Microsoft are either registered trademarks or trademarks of Microsoft Corporation.

Summary of Changes

The information below summarizes the changes made to this manual since its first release (December 2003) of the EtherNet/IP adapter FRN 1.xxx:

Description of Changes	Page(s)
Corrected the values in the Input Size and Output Size columns in Table 4.A.	4-6

Preface	About This Manual	
	Related Documentation	P-1
	Conventions Used in this Manual	P-2
	Rockwell Automation Support	P-2
Chapter 1	Getting Started	
	Components	1-1
	Features	1-2
	Compatible Products	1-3
	Required Equipment	1-3
	Safety Precautions	1-4
	Quick Start	1-5
	Modes of Operation	1-6
Chapter 2	Installing the Adapter	
	Preparing for an Installation	2-1
	Setting Operating Mode and Web Pages Switches	2-1
	Connecting the Adapter to the Network	2-3
	Connecting the Adapter to the Drive	2-4
	Applying Power	2-6
	Commissioning the Adapter	2-6
Chapter 3	Configuring the Adapter	
	Configuration Tools	3-1
	Using the PowerFlex 4-Class HIM	3-2
	Using BOOTP	3-3
	Setting the IP Address, Subnet Mask, and Gateway Address	3-5
	Setting the Data Rate	3-7
	Setting the I/O Configuration	3-7
	Setting a Fault Action	3-8
	Setting Web Features Access	3-10
	Resetting the Adapter	3-11
	Viewing the Adapter Configuration	3-12
Chapter 4	Configuring the Scanner or Bridge	
	Example Network	4-1
	Adding a Bridge or Scanner to the I/O Configuration	4-2
	Adding the Adapter and Drive to the I/O Configuration	4-4
	Saving the Configuration	4-7

Chapter 5	Using I/O Messaging	
	About I/O Messaging	5-1
	Understanding the I/O Image	5-2
	Using Logic Command/Status	5-2
	Using Reference/Feedback	5-3
	Example Ladder Logic Program	5-3
Chapter 6	Using Explicit Messaging	
	About Explicit Messaging	6-1
	Formatting Explicit Messages	6-2
	Performing Explicit Messages	6-4
	About the Example Explicit Messages	6-5
	Example Get Attribute Single Message	6-6
	Example Set Attribute Single Message	6-8
Chapter 7	Using Multi-Drive Mode	
	Single Mode vs. Multi-Drive Mode	7-1
	System Wiring	7-3
	Understanding the I/O Image	7-4
	Configuring the RS-485 Network	7-5
	Multi-Drive Ladder Logic Program Example	7-6
	ControlLogix Example	7-7
	Multi-Drive Mode Explicit Messaging	7-20
	Additional Information	7-22
Chapter 8	Troubleshooting	
	Locating the Status Indicators	8-1
	PORT Status Indicator	8-2
	MOD Status Indicator	8-3
	Net A Status Indicator	8-4
	Net B Status Indicator	8-5
	Adapter Diagnostic Items in Single Drive Mode	8-5
	Adapter Diagnostic Items in Multi-Drive Mode	8-7
	Viewing and Clearing Events	8-8
Chapter 9	Viewing the Adapter's Web Pages	
	Accessing the Adapter's Web Home Page	9-1
	Process Display Pop-up Windows	9-6
	TCP/IP Configuration Web Page	9-7
	Configure E-mail Notification Web Page	9-8
	Configure Process Display Web Page	9-10
	DSI Device Information Pages	9-11

Appendix A	Specifications	
	Communications	A-1
	Electrical	A-1
	Mechanical	A-1
	Environmental	A-2
	Regulatory Compliance	A-2
Appendix B	Adapter Parameters	
	About Parameter Numbers	B-1
	Parameter List	B-1
Appendix C	EtherNet/IP Objects	
	Identity Object	C-2
	Assembly Object	C-4
	Register Object	C-6
	Parameter Object	C-9
	Parameter Group Object	C-13
	PCCC Object	C-15
	DPI Device Object	C-21
	DPI Parameter Object	C-24
	DPI Fault Object	C-28
	DPI Diagnostic Object	C-30
	TCP/IP Interface Object	C-32
	Ethernet Link Object	C-34
Appendix D	Logic Command/Status Words	
	PowerFlex 4 and PowerFlex 40 Drives	D-1
	Glossary	
	Index	

About This Manual

Topic	Page
Related Documentation	P-1
Conventions Used in this Manual	P-2
Rockwell Automation Support	P-2

Related Documentation

For:	Refer to:	Publication
EtherNet/IP	<i>EtherNet/IP Planning and Installation Manual</i> <i>EtherNet/IP Performance and Application Guide</i>	ENET-IN001... ENET-AP001...
DriveExplorer™	http://www.ab.com/drives/driveexplorer , and DriveExplorer Online Help (installed with the software)	—
DriveTools™ SP	http://www.ab.com/drives/drivetools , and DriveTools SP Online Help (installed with the software)	—
HIM	<i>HIM Quick Reference</i>	22HIM-QR001...
PowerFlex® 4 Drive	<i>PowerFlex 4 User Manual</i> <i>PowerFlex 4 Quick Start</i>	22A-UM001... 22A-QS001...
PowerFlex® 40 Drive	<i>PowerFlex 40 User Manual</i> <i>PowerFlex 40 Quick Start</i>	22B-UM001... 22B-QS001...
RSLinx™	<i>Getting Results with RSLinx Guide</i> Online help (installed with the software)	LINX-GR001...
RSLogix™ 5	<i>RSLogix 5 Getting Results Guide</i> Online help (installed with the software)	LG5-GR001...
RSLogix™ 500	<i>RSLogix 500 Getting Results Guide</i> Online help (installed with the software)	LG500-GR001 ...
RSLogix™ 5000	<i>RSLogix 5000 Getting Results Guide</i> Online help (installed with the software)	9399-RLD300G R
RSNetWorx™ for EtherNet/IP	<i>RSNetWorx for EtherNet/IP Getting Results Guide</i> Online help (installed with the software)	ENET-GR001...
ControlLogix™ and 1756-ENBT or 1756-ENET/B	<i>ControlLogix EtherNet Bridge Module User Manual</i> <i>ControlLogix EtherNet Communications Module User Manual</i>	1756-UM050... 1756-UM051...

Documentation can be obtained online at <http://www.ab.com/manuals>.

Conventions Used in this Manual

The following conventions are used throughout this manual:

- Parameter names are shown in the format **Parameter xx - [*]**. The xx represents the parameter number. The * represents the parameter name. For example **Parameter 01 - [Mode]**.
- Menu commands are shown in bold type face and follow the format **Menu > Command**. For example, if you read “Select **File > Open**,” you should click the **File** menu and then click the **Open** command.
- The firmware release is displayed as FRN X.xxx. The “FRN” signifies Firmware Release Number. The “X” is the major release number. The “xxx” is the minor update number.
- RSNetWorx for EtherNet/IP (version 4.01), RSLinx (version 2.40), and RSLogix5000 (version 11) were used for the screen shots in this manual. Different versions of the software may differ in appearance and procedures.
- This manual provides information about the 22-COMM-E EtherNet/IP adapter and using it with PowerFlex 40 drives. The adapter can be used with other products that support an internal DSI adapter. Refer to the documentation for your product for specific information about how it works with the adapter.

Rockwell Automation Support

Rockwell Automation, Inc. offers support services worldwide, with over 75 sales/support offices, over 500 authorized distributors, and over 250 authorized systems integrators located through the United States alone. In addition, Rockwell Automation, Inc. representatives are in every major country in the world.

Local Product Support

Contact your local Rockwell Automation, Inc. representative for:

- Sales and order support
- Product technical training
- Warranty support
- Support service agreements.

Technical Product Assistance

If you need to contact Rockwell Automation, Inc. for technical assistance, please review the information in [Chapter 8, Troubleshooting](#) first. If you still have problems, then call your local Rockwell Automation, Inc. representative.

U.S. Allen-Bradley Drives Technical Support:

E-mail: support@drives.ra.rockwell.com

Tel: (1) 262.512.8176

Fax (1) 262.512.2222

Online: www.ab.com/support/abdrives

UK Customer Support Center:

E-mail: esupport2@ra.rockwell.com

Tel: +44 (0) 870 2411802

Fax: +44 (0) 1908 838804

Germany Customer Service Center:

E-mail: ragermany-csc@ra.rockwell.com

Tel: +49 (0) 2104 960-630

Fax: +49 (0) 2104 960-501

Notes:

Getting Started

The 22-COMM-E EtherNet/IP adapter is a communication option intended for installation into a PowerFlex 40 drive. It can also be used with other Allen-Bradley products that support an internal DSI adapter. The Multi-Drive feature ([Chapter 7](#)) also provides a means for PowerFlex 4 drives and other DSI Hosts to connect to EtherNet/IP.

Topic	Page	Topic	Page
Components	1-1	Safety Precautions	1-4
Features	1-2	Quick Start	1-5
Compatible Products	1-3	Modes of Operation	1-6
Required Equipment	1-3		

Components

Figure 1.1 Components of the Adapter

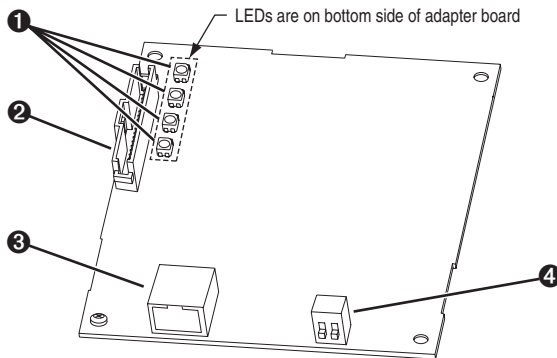

Item	Part	Description
❶	Status Indicators	Four LEDs that indicate the status of the Ethernet connection, DSI, and the adapter. Refer to Chapter 8, Troubleshooting .
❷	DSI Connector	A 20-pin, single-row shrouded male header. An Internal Interface cable is connected to this connector and a connector on the drive.
❸	Ethernet Connector	An RJ-45 connector for the Ethernet cable. The connector is CAT-5 compliant to ensure reliable data transfer on 100Base-TX Ethernet connections.
❹	Operating Mode Switch and Web Pages Switch	Selects Single or Multi-Drive mode of operation, and enables or disables the adapter web pages. Refer to Chapter 2, Setting Operating Mode and Web Pages Switches .

Features

The EtherNet/IP adapter features the following:

- The adapter is mounted in the PowerFlex 40 drive. It receives the required power from the drive.
- A switch lets you select between Single or Multi-Drive mode of operation. In Single mode (default), the adapter represents a single drive on one node. In Multi-Drive mode, the adapter represents up to 5 drives on one node.
- A switch lets you enable or disable (default) the adapter web pages.
- A number of configuration tools can be used to configure the adapter and connected drive. The tools include an external PowerFlex 4-Class HIM (22-HIM-*), network software such as RSNetWorx for EtherNet/IP, or drive-configuration software such as DriveExplorer (version 3.01 or higher) or DriveExecutive (version 3.01 or higher). In addition, you can use a BOOTP server to configure the network features on the adapter (for example, the IP address).
- Status indicators report the status of the drive communications, adapter, and network.
- I/O, including Logic Command/Reference, may be configured for your application using a parameter.
- Explicit Messages are supported.
- User-defined fault actions determine how the adapter and PowerFlex drive respond to communication disruptions on the network and controllers in idle mode.
- Each adapter has Web pages that display information about the adapter, the connected drive, and other DSI devices connected to the drive. The adapter can also be configured to send e-mail messages to desired addresses when selected drive faults occur and/or are cleared, and/or when the adapter takes a communication or idle fault action.

Compatible Products

The EtherNet/IP adapter is compatible with Allen-Bradley PowerFlex Component Class drives and other products that support an internal DSI adapter. At the time of publication, compatible products include:

- PowerFlex 40 drives

The Multi-Drive feature ([Chapter 7](#)) also provides a means for PowerFlex 4 drives and other DSI Hosts to connect to EtherNet/IP.

Required Equipment

Equipment Shipped with the Adapter

When you unpack the adapter, verify that the package includes:

- One EtherNet/IP adapter
- A 15.24 cm (6 in.) Internal Interface Cable
- This manual

User-Supplied Equipment

To install and configure the EtherNet/IP adapter, you must supply:

- A small flathead or Phillips® screwdriver
- Ethernet cable (refer to the *EtherNet/IP Media Planning and Installation Manual*, Publication No. ENET-IN001..., for details)
- Configuration tool, such as:
 - PowerFlex 4-Class HIM (22-HIM-*)
 - DriveExplorer (version 3.01 or higher)
 - DriveExecutive (version 3.01 or higher)
 - RSNetWorx for EtherNet/IP
 - BOOTP Server (version 2.1 or higher) (network setup only)
- A PC connection to the EtherNet/IP network.
- Controller configuration software
(Examples: RSLogix5, RSLogix500, or RSLogix 5000)

Phillips is a registered trademark of the Phillips Screw Company.

Safety Precautions

Please read the following safety precautions carefully.



ATTENTION: Risk of injury or death exists. The PowerFlex drive may contain high voltages that can cause injury or death. Remove all power from the PowerFlex drive, and then verify power has been removed before installing or removing an EtherNet/IP adapter.



ATTENTION: Risk of injury or equipment damage exists. Only personnel familiar with drive and power products and the associated machinery should plan or implement the installation, start-up, configuration, and subsequent maintenance of the product using an EtherNet/IP adapter. Failure to comply may result in injury and/or equipment damage.



ATTENTION: Risk of equipment damage exists. The EtherNet/IP adapter contains ESD (Electrostatic Discharge) sensitive parts that can be damaged if you do not follow ESD control procedures. Static control precautions are required when handling the adapter. If you are unfamiliar with static control procedures, refer to *Guarding Against Electrostatic Damage*, Publication 8000-4.5.2.



ATTENTION: Risk of injury or equipment damage exists. If the EtherNet/IP adapter is transmitting control I/O to the drive, the drive may fault when you reset the adapter. Determine how your drive will respond before resetting an adapter.



ATTENTION: Risk of injury or equipment damage exists. **Parameters 18 - [Comm Flt Action]** and **19 - [Idle Flt Action]** let you determine the action of the adapter and connected PowerFlex drive if communications are disrupted. By default, these parameters fault the drive. You can set these parameters so that the drive continues to run. Precautions should be taken to ensure that the settings of these parameters do not create a risk of injury or equipment damage. When commissioning the drive, verify that your system responds correctly to various situations (for example, a disconnected cable or a faulted controller).



ATTENTION: Hazard of injury or equipment damage exists. When a system is configured for the first time, there may be unintended or incorrect machine motion. Disconnect the motor from the machine or process during initial system testing.



ATTENTION: Hazard of injury or equipment damage exists. The examples in this publication are intended solely for purposes of example. There are many variables and requirements with any application. Rockwell Automation, Inc. does not assume responsibility or liability (to include intellectual property liability) for actual use of the examples shown in this publication.

Quick Start

This section is provided to help experienced users quickly start using the EtherNet/IP adapter. If you are unsure how to complete a step, refer to the referenced chapter.

Step		Refer to . . .
1	Review the safety precautions for the adapter.	Throughout This Manual
2	Verify that the PowerFlex drive is properly installed.	Drive User Manual
3	Install the adapter. Verify that the PowerFlex drive is not powered. Then, connect the adapter to the network using an Ethernet cable and to the drive using the Internal Interface cable. Use the captive screw to secure and ground the adapter to the drive.	Chapter 2, Installing the Adapter
4	Apply power to the adapter. The adapter receives power from the drive. Apply power to the drive. The status indicators should be green. If they flash red, there is a problem. Refer to Chapter 8, Troubleshooting .	Chapter 2, Installing the Adapter
5	Configure the adapter for your application. Set the following parameters for the adapter as required by your application: <ul style="list-style-type: none"> • IP address, subnet mask, and gateway address • Data rate • I/O configuration • Fault actions 	Chapter 3, Configuring the Adapter
6	Create a ladder logic program. Use a programming tool such as RSLogix to create a ladder logic program that enables you to: <ul style="list-style-type: none"> • Control the adapter and connected drive using I/O. • Monitor or configure the drive using Explicit Messages. 	Chapter 4, Configuring the Scanner or Bridge Chapter 5, Using I/O Messaging Chapter 6, Using Explicit Messaging

Modes of Operation

The adapter uses four status indicators to report its operating status. They can be viewed on the adapter or through the drive cover. See [Figure 1.2](#).

Figure 1.2 Status Indicators (location on drive may vary)

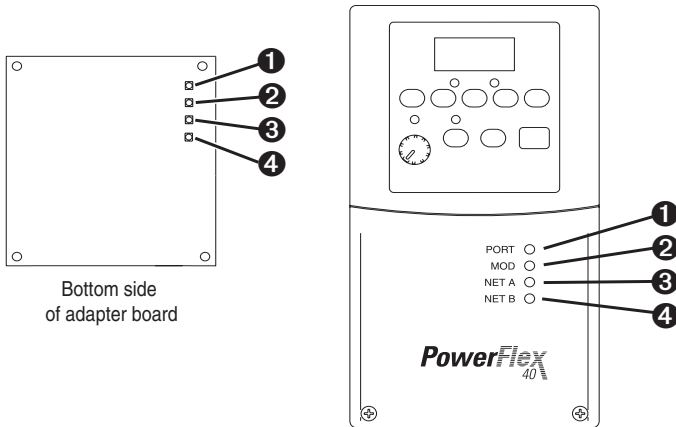

Item	Status Indicator	Status ⁽¹⁾	Description
①	PORT	Green	Normal Operation. The adapter is properly connected and is communicating with the drive.
		Flashing Green	Normal Operation. The adapter is in the process of establishing a connection to the drive. This status indicator will turn solid green or red.
②	MOD	Green	Normal Operation. The adapter is operational and is transferring I/O data.
		Flashing Green	Normal Operation. The adapter is operational but is not transferring I/O data.
③	NET A	Green	Normal Operation. The adapter is properly connected and communicating on the network.
		Flashing Green	Normal Operation. The adapter is properly connected but is not communicating with any devices on the network.
④	NET B	Flashing Green	Normal Operation. The adapter is properly connected and is transmitting data packets on the network.
		Off	Normal Operation. The adapter is not transmitting data packets.

⁽¹⁾ If all status indicators are off, the adapter is not receiving power. Refer to [Chapter 2, Installing the Adapter](#), for instructions on installing the adapter.

If any other conditions occur, refer to [Chapter 8, Troubleshooting](#).

Installing the Adapter

Chapter 2 provides instructions for installing the adapter in a PowerFlex 40 drive.

Topic	Page
Preparing for an Installation	2-1
Setting Operating Mode and Web Pages Switches	2-1
Connecting the Adapter to the Network	2-3
Connecting the Adapter to the Drive	2-4
Applying Power	2-6
Commissioning the Adapter	2-6

Preparing for an Installation

Before installing the EtherNet/IP adapter:

- Read the *EtherNet/IP Performance and Application Guide*, Publication ENET-AP001..., and the *EtherNet/IP Media Planning and Installation Manual*, Publication ENET-IN001...
- Verify that you have all required equipment. Refer to [Chapter 1, Getting Started](#).

Important: To guard against device malfunction, use a grounding wrist strap when installing the EtherNet/IP adapter.

Setting Operating Mode and Web Pages Switches

Before installing the adapter, you must set its Operating Mode Switch for Single or Multi-Drive operation. To use the adapter web pages, the Web Pages Switch must be set to its “Enable Web” position.

Important: New settings are recognized only when power is applied to the adapter, or the adapter is reset. If you change a setting, cycle power or reset the adapter.



ATTENTION: Risk of equipment damage exists. The EtherNet/IP adapter contains ESD (Electrostatic Discharge) sensitive parts that can be damaged if you do not follow ESD control procedures. Static control precautions are required when handling the adapter. If you are unfamiliar with static control procedures, refer to *Guarding Against Electrostatic Damage*, Publication 8000-4.5.2.

1. Set the Operating Mode Switch (SW1) for Single or Multi-Drive operation (see [Figure 2.1](#) and setting descriptions below). For complete details on Multi-Drive mode operation, see [Chapter 7, Using Multi-Drive Mode](#).

Figure 2.1 Setting Single/Multi-Drive Operation and Web Page Enable Switches

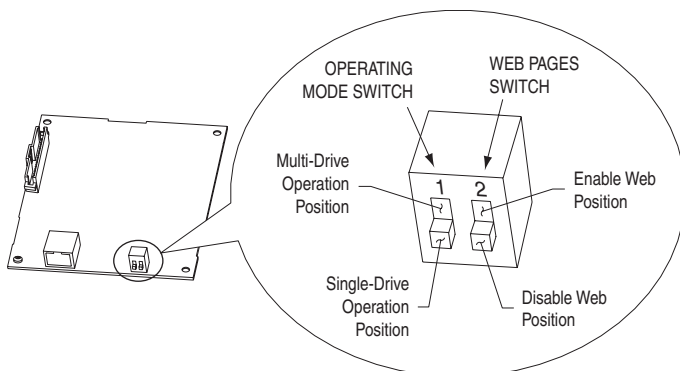

SW1 Setting	Description
Down position (DN = Closed = 0)	<p>Sets the adapter for Single drive mode (default setting) using a single drive connection.</p> <p>Important: In this mode, connections to multiple drives must be removed since all powered and connected hosts will respond to any message sent by the adapter.</p>
Up position (UP = Open = 1)	<p>Sets the adapter for Multi-Drive operation mode using up to 5 different drives. DSI peripherals (22-HIM-*, 22-SCM-*, etc.) do not operate with the adapter in this mode.</p>

2. Set the Web Pages Switch (SW2) to enable or disable the adapter web pages (see [Figure 2.1](#) and setting descriptions below). By default, the adapter web pages are disabled. For complete details on the adapter web pages, see [Chapter 9, Viewing the Adapter's Web Pages](#).

SW2 Setting	Description
Down position (DN = Closed = 0)	Disables the adapter web pages (default setting).
Up position (UP = Open = 1)	Enables the adapter web pages.

Connecting the Adapter to the Network



ATTENTION: Risk of injury or death exists. The PowerFlex drive may contain high voltages that can cause injury or death. Remove power from the PowerFlex drive, and then verify power has been discharged before installing or removing an adapter.

1. Remove power from the drive.
2. Use static control precautions.
3. Remove the drive cover.
4. Connect an Ethernet cable to the EtherNet/IP network. See [Figure 2.2](#) for an example of wiring to an EtherNet/IP network.

Figure 2.2 Connecting the Ethernet Cable to the Network

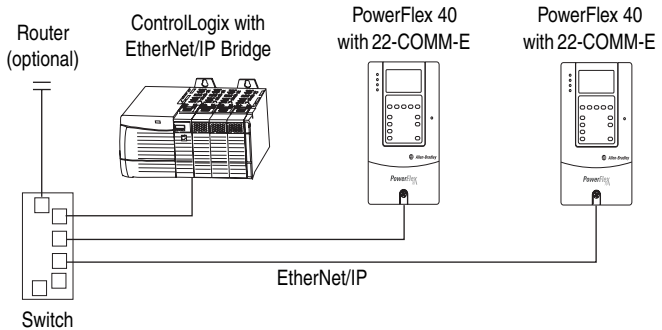

5. Route the Ethernet cable through the bottom of the PowerFlex drive ([Figure 2.3](#)), and insert the cable's plug into the mating adapter receptacle.

Connecting the Adapter to the Drive

1. Remove power from the drive.
2. Use static control precautions.
3. Mount the adapter on the *required special* drive cover (ordered separately — see [Figure 2.4](#) for part numbers).
 - C Frame: Use the adapter screw to secure the adapter to the cover.
 - B Frame: Disregard the screw and snap the adapter in place.

Important: For C Frame drives, tighten the adapter’s lower left screw to ground the adapter (see [Figure 2.4](#)). For B Frame drives, install the special drive cover onto the drive using both cover fasteners to ground the adapter.

4. Connect the Internal Interface cable to the DSI port on the drive and then to the mating DSI connector on the adapter.

Figure 2.3 DSI Ports and Internal Interface Cables

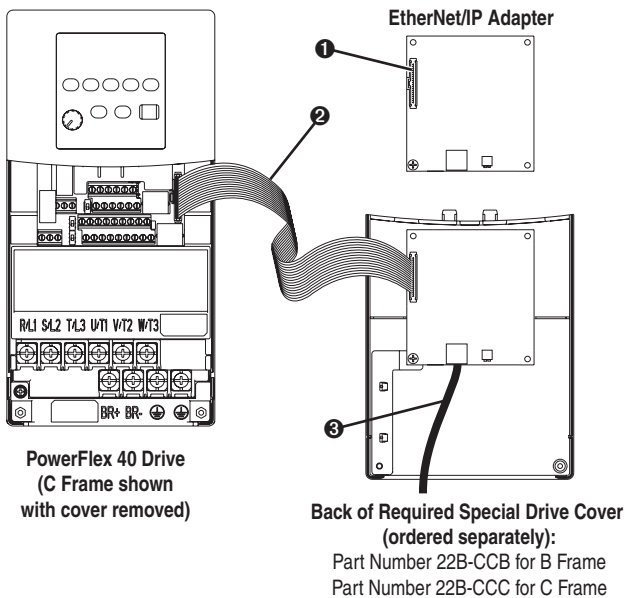

Item	Description
❶	DSI Connector
❷	15.24 cm (6 in.) Internal Interface cable
❸	Ethernet cable

Figure 2.4 Mounting and Grounding the Adapter

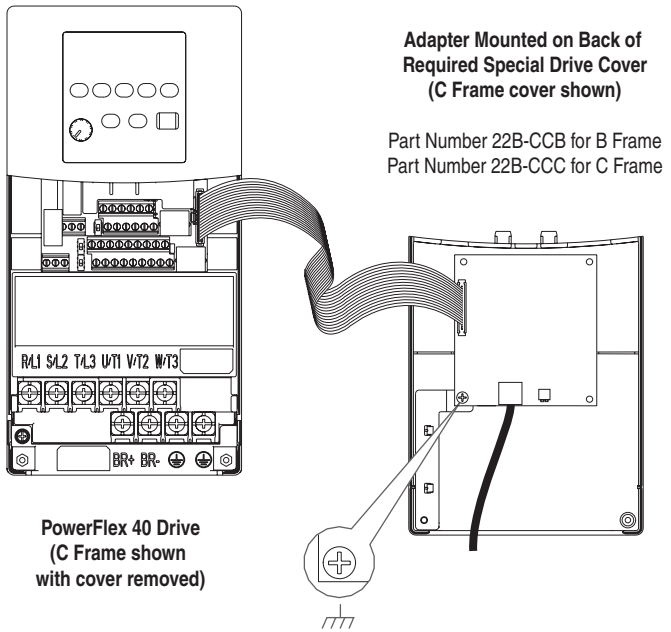

Ground for C Frame drives

NOTE: For B Frame drives, the lower left adapter screw does not ground the adapter. To ground the adapter, install the special drive cover onto the drive using both cover fasteners.

Applying Power



ATTENTION: Risk of equipment damage, injury, or death exists. Unpredictable operation may occur if you fail to verify that parameter settings and switch settings are compatible with your application. Verify that settings are compatible with your application before applying power to the drive.

1. Install the *required special* cover on the drive. The status indicators can be viewed on the front of the drive after power has been applied.
2. Apply power to the PowerFlex drive. The adapter receives its power from the connected drive. When you apply power to the product for the first time, the status indicators should be green or off after an initialization. If the status indicators go red, there is a problem. Refer to [Chapter 8, Troubleshooting](#).

Commissioning the Adapter

To commission the adapter, you must set a unique IP address. (Refer to the [Glossary](#) for details about IP addresses.) After installing the adapter and applying power, you can set the IP address by using a BOOTP server or by setting parameters.

By default, the adapter is configured so that you must set the IP address using a BOOTP server. To set the IP address using parameters, you must disable the BOOTP feature. Refer to [Chapter 3, Configuring the Adapter](#), for details.

Important: New settings for some parameters (for example, **Parameters 03 - [IP Addr Cfg 1]** through **06 - [IP Addr Cfg 4]**) are recognized only when power is applied to the adapter or it is reset. After you change parameter settings, cycle power or reset the adapter.

Configuring the Adapter

Chapter 3 provides instructions and information for setting the parameters in the adapter.

Topic	Page	Topic	Page
Configuration Tools	3-1	Setting the I/O Configuration	3-7
Using the PowerFlex 4-Class HIM	3-2	Setting a Fault Action	3-8
Using BOOTP	3-3	Setting Web Features Access	3-10
Setting the IP Address, Subnet Mask, and Gateway Address	3-5	Resetting the Adapter	3-11
Setting the Data Rate	3-7	Viewing the Adapter Configuration	3-12

For a list of parameters, refer to [Appendix B, Adapter Parameters](#). For definitions of terms in this chapter, refer to the [Glossary](#).

Configuration Tools

The EtherNet/IP adapter stores parameters and other information in its own non-volatile memory. You must, therefore, access the adapter to view and edit its parameters. The following tools can be used to access the adapter parameters:

Tool	Refer to . . .
PowerFlex 4-Class HIM (22-HIM-*)	page 3-2
BOOTP Server	page 3-3
DriveExplorer Software (version 3.01 or higher)	DriveExplorer Online help (installed with the software)
DriveExecutive Software (version 3.01 or higher)	DriveExecutive Online help (installed with the software)

Using the PowerFlex 4-Class HIM

The PowerFlex 4-Class HIM (Human Interface Module) can be used to access parameters in the adapter (see basic steps shown below). It is recommended that you read through the steps for your HIM before performing the sequence. For additional HIM information, refer to the HIM Quick Reference card.

Using the HIM

Step	Key(s)	Example Screens
1. Power up the drive. Then plug the HIM into the drive. The Parameters menu for the <u>drive</u> will be displayed.		
2. Press Sel key once to display the Device Select menu.		
3. Press Enter to display the DSI Devices menu. Press Down Arrow to scroll to 22-COMM-E.	and	
4. Press Enter to select the EtherNet/IP adapter. The Parameters menu for the <u>adapter</u> will be displayed.		
5. Press Enter to access the parameters. Edit the adapter parameters using the same techniques that you use to edit drive parameters.		

Using BOOTP

By default, the adapter is configured so that you can set its IP address, subnet mask, and gateway address by using a BOOTP utility. You can select from a variety of BOOTP utilities. These instructions use Rockwell's BOOTP Server (version 2.1), a stand-alone program that incorporates the functionality of standard BOOTP utilities with a graphical interface. It is available from <http://www.ab.com/networks>. Refer to the Readme file and online Help for detailed directions and information.



TIP: If desired, you can disable BOOTP and configure the IP address, subnet mask, and gateway address by setting parameters. For details, refer to [Setting the IP Address, Subnet Mask, and Gateway Address](#) in this chapter.

To configure the adapter using BOOTP Server

1. On the label of the adapter, locate and note the hardware address of the adapter.
2. On a computer connected to the EtherNet/IP network, start the BOOTP software. The BOOTP Server window appears ([Figure 3.1](#)). Devices on the network issuing BOOTP requests appear in the BOOTP Request History list.

Figure 3.1 BOOTP Server Window

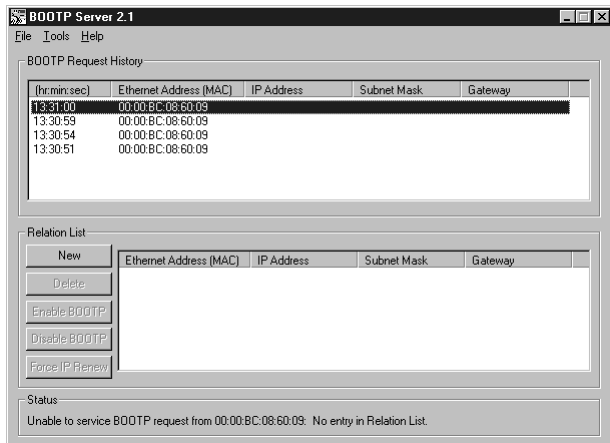

3. In the BOOTP Request History list, double-click the hardware address (Ethernet MAC address) of the adapter. The New Entry dialog box appears ([Figure 3.2](#)).

Figure 3.2 New Entry Dialog Box

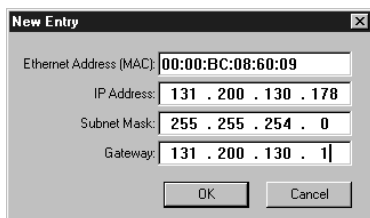

4. Edit the following:

Box ⁽¹⁾	Type
IP Address	A unique IP address for the adapter
Subnet Mask	The subnet mask for the adapter's network
Gateway	The IP address of the gateway device on the adapter's network

(1) For definitions, refer to the [Glossary](#).

5. Click **OK** to apply the settings. The adapter appears in the Relation List with the new settings ([Figure 3.3](#)).

Figure 3.3 BOOTP Server Window with an Adapter in the Relation List

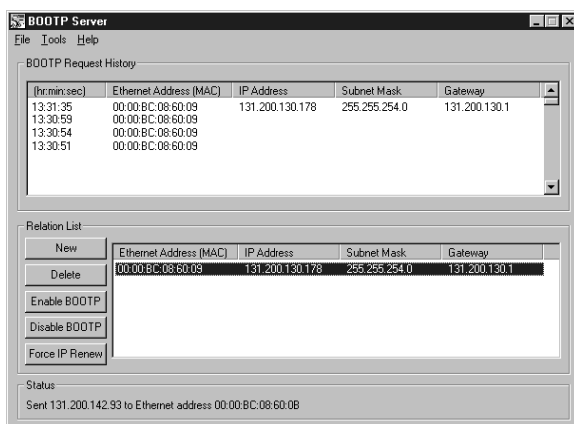

6. To assign this configuration to the adapter permanently, click **Disable BOOTP**. When power is cycled on the adapter, it will use the configuration you assigned it and not issue new BOOTP requests.



TIP: To enable BOOTP for an adapter that has had BOOTP disabled, first select the adapter in the Relation List, then click **Enable BOOTP**, and finally reset the adapter.

7. To save the Relation List, select **File > Save**.

3. Reset the adapter. See [Resetting the Adapter](#) section in this chapter.

The Net A status indicator will be solid green or flashing green if the IP address is correctly configured.

To set a subnet mask using parameters

1. Verify that **Parameter 02 - [BOOTP]** is set to **Disabled**. This parameter must be set to Disabled in order to configure the subnet mask using parameters.
2. Set the value of **Parameters 07 - [Subnet Cfg 1]** through **10 - [Subnet Cfg 4]** to the desired value for the subnet mask.

Figure 3.6 Example Subnet Mask Screen on PowerFlex 4-Class HIM (22-HIM-*)

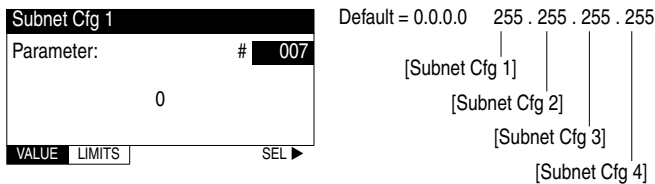

3. Reset the adapter. See [Resetting the Adapter](#) section in this chapter.

To set a gateway address for the adapter using parameters

1. Verify that **Parameter 02 - [BOOTP]** is set to **Disabled**. This parameter must be set to Disabled in order to configure the gateway address using parameters.
2. Set the value of **Parameters 11 - [Gateway Cfg 1]** through **14 - [Gateway Cfg 4]** to the IP address of the gateway device.

Figure 3.7 Example Gateway Screen on PowerFlex 4-Class HIM (22-HIM-*)

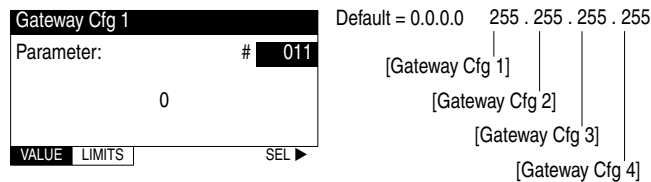

3. Reset the adapter. See [Resetting the Adapter](#) section in this chapter.

Setting the Data Rate

By default, the adapter is set to autodetect, so it automatically detects the data rate and duplex setting used on the network. If you need to set a specific data rate and duplex setting, the value of **Parameter 15 - [EN Rate Cfg]** determines the Ethernet data rate and duplex setting that the adapter will use to communicate. For definitions of data rate and duplex, refer to the [Glossary](#).

1. Set the value of **Parameter 15 - [EN Rate Cfg]** to the data rate at which your network is operating.

Figure 3.8 Ethernet Data Rate Screen on PowerFlex 4-Class HIM (22-HIM-*)

Value	Data Rate
0	Autodetect (default)
1	10M bits/sec Full
2	10M bits/sec Half
3	100M bits/sec Full
4	100M bits/sec Half

EN Rate Cfg	
Parameter:	# 015
0	
VALUE	LIMITS
	SEL ▶

2. Reset the adapter. See [Resetting the Adapter](#) section in this chapter.

Setting the I/O Configuration

The I/O configuration determines the number of drives that will be represented on the network as one node by the adapter. If the Mode Switch is set to the Single mode (default) position, only one drive is represented by the adapter and **Parameter 22 - [DSI I/O Cfg]** has no effect. If the Operating Mode Switch is set to the Multi-Drive position, up to five drives can be represented as one node by the adapter.

1. Set the value in **Parameter 22 - [DSI I/O Cfg]**.

Figure 3.9 I/O Configuration Screen on Powerflex 4-Class HIM (22-HIM-*)

Value	Description	Mode Switch Position	
		Single	Multi-Drive
0	Drive 0 (Default)	✓	✓
1	Drives 0-1		✓
2	Drives 0-2		✓
3	Drives 0-3		✓
4	Drives 0-4		✓

DSI I/O Cfg	
Parameter:	# 022
Drive 0	0
VALUE	LIMITS
	SEL ▶

Drive 0 is the PowerFlex 40 with the 22-COMM-E adapter installed. Drive 1 through 4 are PowerFlex 4 and/or 40 drives that multi-drop to the RJ45 (RS-485) port on Drive 0. Refer to [Chapter 7, Using Multi-Drive Mode](#) for more information.

2. If a drive is enabled, configure the parameters in the drive to accept the Logic Command and Reference from the adapter. For example, set **Parameters 36 - [Start Source]** and **38 - [Speed Reference]** in a PowerFlex 40 drive to “Comm Port.”
3. Reset the adapter. See [Resetting the Adapter](#) section in this chapter.

Setting a Fault Action

By default, when communications are disrupted (for example, a cable is disconnected) or the scanner is idle, the drive responds by faulting if it is using I/O from the network. You can configure a different response to communication disruptions using **Parameter 18 - [Comm Flt Action]** and a different response to an idle scanner using **Parameter 19 - [Idle Flt Action]**.



ATTENTION: Risk of injury or equipment damage exists. **Parameters 18 - [Comm Flt Action]** and **19 - [Idle Flt Action]** let you determine the action of the adapter and connected drive if communications are disrupted or the scanner is idle. By default, these parameters fault the drive. You can set these parameters so that the drive continues to run. Precautions should be taken to ensure that the settings of these parameters do not create a risk of injury or equipment damage. When commissioning the drive, verify that your system responds correctly to various situations (for example, a disconnected cable or faulted controller).

To change the fault action

- Set the values of **Parameters 18 - [Comm Flt Action]** and **19 - [Idle Flt Action]** to the desired responses:

Value	Action	Description
0	Fault	The drive is faulted and stopped. (Default)
1	Stop	The drive is stopped, but not faulted.
2	Zero Data	The drive is sent 0 for output data after a communications disruption. This does not command a stop.
3	Hold Last	The drive continues in its present state after a communications disruption.
4	Send Flt Cfg	The drive is sent the data that you set in the fault configuration parameters (Parameters 20 - [Flt Cfg Logic] and 21 - [Flt Cfg Ref]).

Figure 3.10 Fault Action Screens on PowerFlex 4-Class HIM (22-HIM-*)

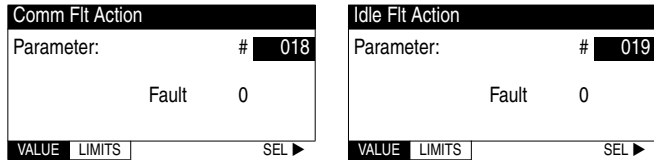

Changes to these parameters take effect immediately. A reset is not required.

If Multi-Drive mode is used, the same fault action is used by the adapter for all of the drives it controls (Drive 0 - Drive 4).

To set the fault configuration parameters

If you set **Parameter 18 - [Comm Flt Action]** or **19 - [Idle Flt Action]** to the “Send Flt Cfg,” the values in the following parameters are sent to the drive after a communications fault and/or idle fault occurs. You must set these parameters to values required by your application.

Parameter	Name	Description
20	Flt Cfg Logic	A 16-bit value sent to the drive for Logic Command.
21	Flt Cfg Ref	A 16-bit value (0 – 65535) sent to the drive as a Reference.

Changes to these parameters take effect immediately. A reset is not required.

Setting Web Features Access

By accessing the IP address set for the adapter using a web browser, you can view the adapter's web pages for information about the adapter, the PowerFlex drive to which it is connected, and other DSI devices connected to the drive such as HIMs, serial adapters or other daisy-chained drives (when adapter is in Multi-Drive mode). Additionally, the adapter can be configured to automatically send e-mail messages to desired addresses when selected drive faults occur and/or are cleared, and/or when the adapter takes a communication or idle fault action. For more details on the adapter's web pages, refer to [Chapter 9, Viewing the Adapter's Web Pages](#).

By default, the adapter web pages are disabled.

To enable the adapter web pages

- Refer to [Figure 2.1](#) and set the Web Pages Switch (SW2) to the "Enable Web" (up) position.

Important: For a change to the switch setting to take effect, the adapter must be reset (see [Resetting the Adapter](#) section in this chapter).

Bit 0 of **Parameter 30 - [Web Features]** is used to protect the configured settings for e-mail notification. By default, settings are not protected. To protect an e-mail configuration, set the value of E-mail Cfg Bit 0 to "0" (Disabled). You can unprotect the configuration by changing Bit 0 back to "1" (Enabled). E-mail notification will always remain active regardless of whether or not its settings are protected — unless e-mail notification was *never* configured. For more information about configuring adapter e-mail notification or stopping e-mail messages, refer to [Chapter 9, Configure E-mail Notification Web Page](#).

Figure 3.11 Web Features Screen on Powerflex 4-Class HIM (22-HIM-*)

Bit	Description
0	E-mail Cfg (Default = 1 = Enabled)
1	Proc Dsp Cfg (Default = 1 = Enabled)
2-7	Not Used

Access Control	
Parameter:	# 030
	x x x x x 1 1
VALUE	LIMITS
	SEL ▶

Bit 0 is the right-most bit. In [Figure 3.11](#) it is highlighted and equals "1."

Changes to this parameter take effect immediately. A reset is not required.

Bit 1 of **Parameter 30 - [Web Features]** protects the configuration of parameters (names and values) shown in the “Process status” fields on both the Home page (Single Mode only) and Process Display pop-up window. By default, this configuration is not protected. To protect the configuration, set the value of Proc Dsp Cfg Bit 1 to “0” (Disabled). You can unprotected the configuration by changing Bit 1 back to “1” (Enabled). For more information about configuring the parameters for display, refer to the [Configure Process Display Web Page](#) section in [Chapter 9](#).

Resetting the Adapter

Changes to switch settings and some adapter parameters require that you reset the adapter before the new settings take effect. You can reset the adapter by cycling power to the drive or by using the following parameter:



ATTENTION: Risk of injury or equipment damage exists. If the adapter is transmitting control I/O to the drive, the drive may fault when you reset the adapter. Determine how your drive will respond before resetting a connected adapter.

- Set **Parameter 17 - [Reset Module]** to **Reset Module**.

Figure 3.12 Reset Screen on PowerFlex 4-Class HIM (22-HIM-*)

Reset Module		
Parameter:	#	017
	Ready	0
VALUE	LIMITS	SEL ▶

Value	Description
0	Ready (Default)
1	Reset Module
2	Set Defaults

When you enter **1 = Reset Module**, the adapter will be immediately reset. When you enter **2 = Set Defaults**, the adapter will set all adapter parameters to their factory-default settings. After performing a Set Defaults, enter **1 = Reset Module** so that the new values take effect. The value of this parameter will be restored to **0 = Ready** after the adapter is reset.

Viewing the Adapter Configuration

The following parameters provide information about how the adapter is configured. You can view these parameters at any time.

Number	Name	Description
01	Mode	The mode in which the adapter is set: <u>Values</u> 0 = Single drive operation 2 = Multi-Drive operation
16	EN Rate Act	The data rate used by the adapter: <u>Values</u> 1 = 10M bits/sec full 2 = 10M bits/sec half 3 = 100M bits/sec full 4 = 100M bits/sec half
23	DSI I/O Act	Indicates the Drives that are active in the Multi-Drive mode: <u>Bit Definitions</u> 0 = Drive 0 Active 1 = Drive 1 Active 2 = Drive 2 Active 3 = Drive 3 Active 4 = Drive 4 Active
29	Web Enable	Indicates the setting of the Web Pages Switch (SW2) on the adapter when the adapter was last reset: <u>Values</u> 0 = Disabled 1 = Enabled

Configuring the Scanner or Bridge

Chapter 4 provides instructions on how to configure a ControlLogix bridge to communicate with the adapter and connected PowerFlex drive.

Topic	Page	Topic	Page
Example Network	4-1	Adding the Adapter and Drive to the I/O Configuration	4-4
Adding a Bridge or Scanner to the I/O Configuration	4-2	Saving the Configuration	4-7

Example Network

After the adapter is configured, the connected drive and adapter will be a single node on the network. This chapter provides the steps that are needed to configure a simple network like the network in [Figure 4.1](#). In our example, we will configure a 1756-ENBT bridge to communicate with a drive using Logic Command/Status and Reference/Feedback over the network.

Figure 4.1 Example EtherNet/IP Network

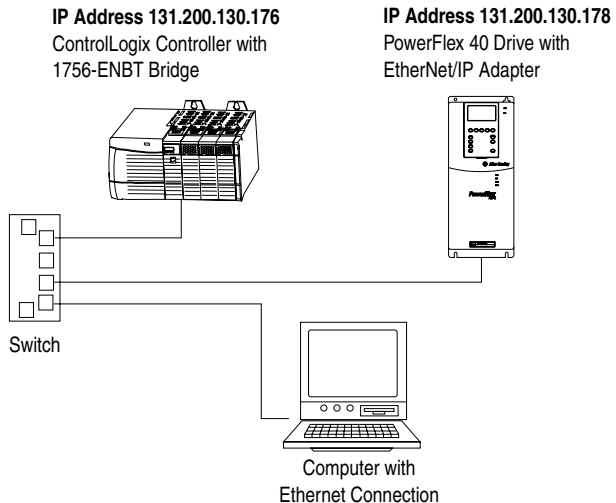

Adding a Bridge or Scanner to the I/O Configuration

To establish communications over an EtherNet/IP network, you must first add the controller and its scanner or bridge to the I/O configuration.

1. Start RSLogix 5000. The RSLogix 5000 window appears.

Figure 4.2 RSLogix 5000 Window

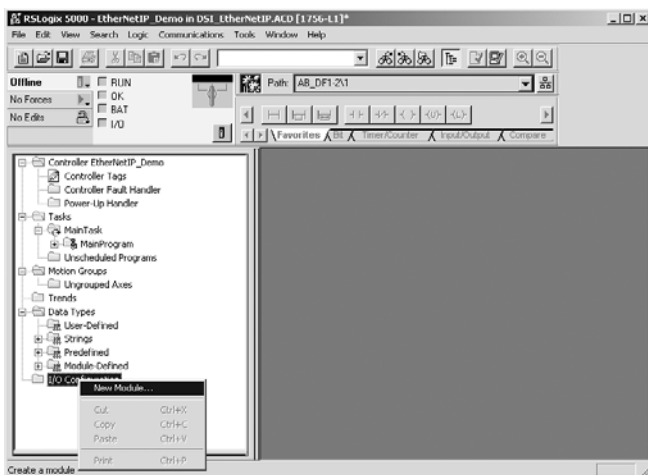

2. In the Control Organizer pane, right-click the **I/O Configuration** folder and select **New Module** (Figure 4.2). The Select Module Type dialog box (Figure 4.3) appears.

Figure 4.3 Select Module Type Dialog Box

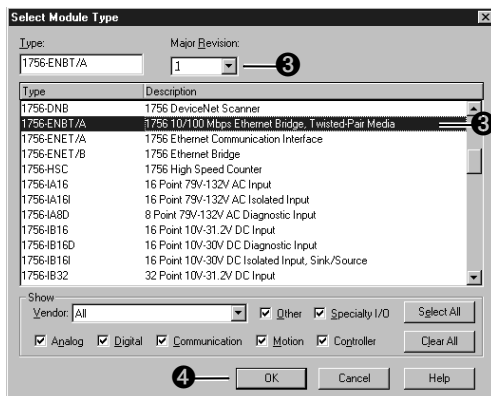

- In the list, select the EtherNet/IP scanner or bridge used by your controller and then select the major revision of its firmware in the Major Revision box. In this example (Figure 4.3), we use a 1756-ENBT EtherNet/IP Bridge (Series A), so the 1756-ENBT/A option is selected.
- Click **OK**. The Module Properties dialog box (Figure 4.4) appears.

Figure 4.4 Module Properties Dialog Box - Page 1

The screenshot shows the 'Module Properties - Local (1756-ENBT/A 2.1)' dialog box. It contains the following fields and values:

- Type: 1756-ENBT/A 1756 10/100 Mbps Ethernet Bridge, Twisted-Pair Media
- Vendor: Allen-Bradley
- Parent: Local
- Name: My_EtherNet_IP
- Description: (empty)
- Address / Host Name:
 - IP Address: 131 . 200 . 130 . 178
 - Host Name: (empty)
- Slot: 1
- Revision: 1
- Electronic Keying: Compatible Module

Buttons at the bottom: Cancel, < Back, Next >, Finish >>, Help.

- Edit the following:

Box	Type
Name	A name to identify the scanner or bridge.
Slot	The slot of the EtherNet/IP scanner or bridge in the rack.
Revision	The minor revision of the firmware in the scanner. (You already set the major revision in the Select Module Type dialog box, Figure 4.3 on page 4-2.)
IP Address	The IP address of the EtherNet/IP scanner or bridge.
Electronic Keying	Compatible Module. This setting for Electronic Keying ensures the physical module is consistent with the software configuration before the controller and scanner or bridge make a connection. Therefore, ensure that you have set the correct revision in this dialog box. Refer to the online Help if the controller and scanner have problems making a connection and you want to change this setting.

- Click **Finish>>**. The scanner or bridge is now configured for the EtherNet/IP network. It appears in the I/O Configuration folder. In our example, a 1756-ENBT bridge appears under the I/O Configuration folder (Figure 4.5).

Figure 4.5 RSLogix 5000: I/O Configuration Folder



Adding the Adapter and Drive to the I/O Configuration

To transmit data between the scanner or bridge and the adapter, you must add the 22-COMM-E adapter as a child device of the scanner or bridge.

1. In the Control Organizer pane, right-click on the scanner or bridge and select **New Module** (Figure 4.6). In our example, we right-click on the 1756-ENBT/A bridge.

Figure 4.6 Right-Clicking on the Scanner

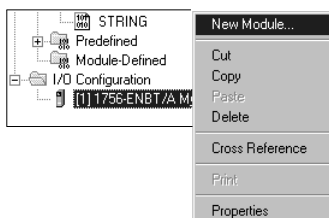

The **Select Module Type** dialog box (Figure 4.7) appears.

Figure 4.7 Select Module Type Dialog Box

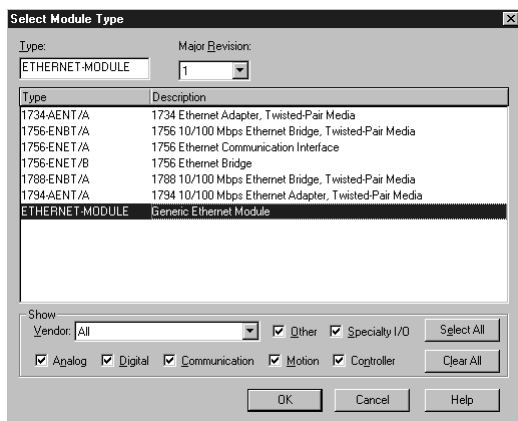

2. Select **ETHERNET-MODULE** to configure a 22-COMM-E (Figure 4.7), and then click **OK**.

The Module Properties dialog box ([Figure 4.8](#)) appears.

Figure 4.8 Module Properties Dialog Box - Page 1

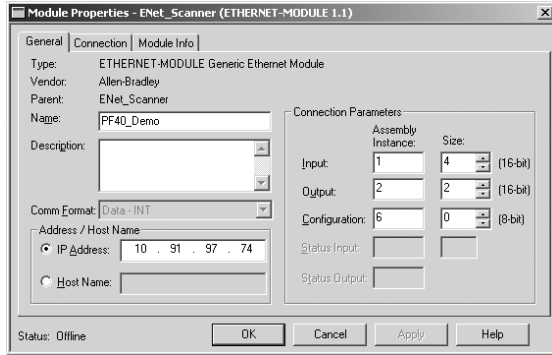

3. Edit the following information about the adapter:

Box	Type
Name	A name to identify the adapter and drive.
Comm. Format	Data - INT. This setting formats the data in 16-bit words.
IP Address	The IP address of the adapter.

4. Under Connection Parameters, edit the following:

Box	Assembly Instance	Size
Input	1 (This value is required.)	The value will vary based on your application (setting of Parameter 22 - [DSI I/O Cfg]). It will contain 2 additional words for ENBT overhead. Refer to Table 4.A on page 4-6 .
Output	2 (This value is required.)	The value will vary based on your application (setting of Parameter 22 - [DSI I/O Cfg]). Refer to Table 4.A on page 4-6 .
Configuration	6 (This value is required.)	0 (This value is required.)

Type the number of bytes that are required for your I/O in the Input Size and Output Size boxes. The size will depend on the I/O that you enabled in the adapter. This information can be found in **Parameter 22 - [DSI I/O Cfg]** in the adapter. [Table 4.A](#) shows common configuration Input/Output sizes.

In our example, we typed 4 in the Input Size and Output Size boxes because the Operating Mode Switch on the adapter is set to “Single” (default) and **Parameter 22 - [DSI I/O Cfg]** is set to “Drive 0” (only one drive being connected). Logic Command/Reference uses 2

words and Logic Status/Feedback uses 2 words. The additional 2 words for the inputs are for ENBT overhead.

Table 4.A Input/Output Size Configurations

Input Size	Output Size	Logic Command/ Status	Reference/ Feedback	Parameter 22 - [DSI I/O Cfg]	Parameter 1 - [Mode]
4	2	✓	✓	Drive 0	Single
6	4	✓	✓	Drives 0-1	Multi-Drive
8	6	✓	✓	Drives 0-2	
10	8	✓	✓	Drives 0-3	
12	10	✓	✓	Drives 0-4	



TIP: For instructions on configuring the I/O for the adapter (**Parameter 22 - [DSI I/O Cfg]**), see [Chapter 3, Configuring the Adapter](#).

5. Click **Next >** to display the next page.

Figure 4.9 Module Properties Dialog Box - Page 2

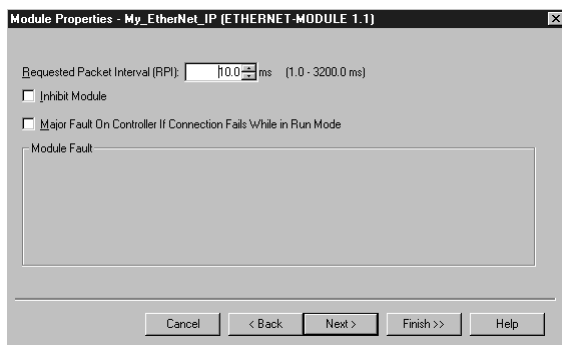

6. In the **Requested Packet Interval (RPI)** box, set the value to 5.0 milliseconds or greater. This value determines the maximum interval that a controller should use to move data to or from the adapter. To conserve bandwidth, use higher values for communicating with low priority devices.
7. Click **Finish>>**. The new node (“PF40_Demo” in this example) now appears under the scanner or bridge (“1756-ENBT” in this example) in the I/O Configuration folder. If you double-click the **Data Types** folder and then double-click on the **Module-Defined** folder, you will see that module-defined data types and tags have been automatically created. After you save and download the configuration, these tags allow you to access the Input and Output data of the adapter via the controller’s ladder logic.

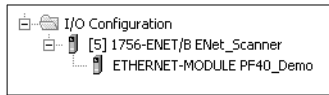
Figure 4.10 RSLogix 5000 - I/O Configuration Folder

Saving the Configuration

After adding the scanner or bridge and the adapter to the I/O configuration, you must download the configuration to the controller. You should also save the configuration to a file on your computer.

1. Select **Communications > Download**. The **Download** dialog box ([Figure 4.11](#)) appears.

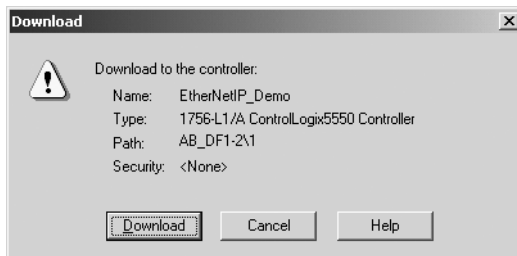
Figure 4.11 Download Dialog Box

► **TIP:** If a message box reports that RSLogix is unable to go online, select **Communications > Who Active** to try to find your controller in the Who Active dialog box. If it does not appear, you need to add or configure the EtherNet/IP driver in RSLinx. Refer to the RSLinx online help.

2. Click **Download** to download the configuration to the controller. When the download is completed successfully, RSLogix enters online mode and the I/O OK box in the upper-left part of the screen is green.
3. Select **File > Save**. If this is the first time that you saved the project, the Save As dialog box appears. Navigate to a folder, type a file name, and click **Save** to save the configuration to a file on your computer.

Notes:

Using I/O Messaging

Chapter 5 provides information and examples that explain how to use a ControlLogix controller to send I/O Messaging to control, configure, and monitor a PowerFlex 40 drive.

Topic	Page	Topic	Page
About I/O Messaging	5-1	Using Reference/Feedback	5-3
Understanding the I/O Image	5-2	Example Ladder Logic Program	5-3
Using Logic Command/Status	5-2		



ATTENTION: Risk of injury or equipment damage exists. The examples in this publication are intended solely for purposes of example. There are many variables and requirements with any application. Rockwell Automation, Inc. does not assume responsibility or liability (to include intellectual property liability) for actual use of the examples shown in this publication.

Important: At the time of publication, only ControlLogix controllers can make an EtherNet/IP network I/O connection as described in this chapter; PLC-5's and SLC's cannot. However, these controllers can perform control using explicit messaging to the CIP Register object and PCCC N41 and N42 files.

About I/O Messaging

On EtherNet/IP, I/O messaging is used to transfer the data which controls the PowerFlex drive and sets its Reference.

The EtherNet/IP adapter provides many options for configuring and using I/O, including configuring the size of I/O by selecting the number of attached drives (Single or Multi-Drive mode).

[Chapter 3, Configuring the Adapter](#), and [Chapter 4, Configuring the Scanner or Bridge](#), discuss how to configure the adapter and scanner or bridge on the network for these options. The [Glossary](#) defines the different options. This chapter discusses how to use I/O after you have configured the adapter and scanner or bridge.

Understanding the I/O Image

The terms *input* and *output* are defined from the scanner's point of view. Therefore, Output I/O is data that is produced by the scanner and consumed by the EtherNet/IP adapter. Input I/O is status data that is produced by the adapter and consumed as input by the scanner. The I/O image table will vary based on the:

- Configuration of the Operating Mode Switch (SW1) on the adapter and (**Parameter 22 - [DSI I/O Cfg]**). The image table always uses consecutive words starting at word 0.

[Figure 5.1](#) illustrates an example of a Single drive I/O image (16-bit words).

Figure 5.1 Single Drive Example of I/O Image

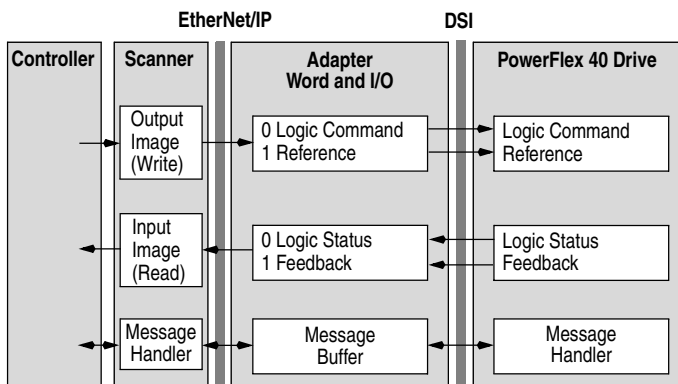

Single mode is the typical configuration, where one node consists of a PowerFlex 40 drive with a 22-COMM-E adapter.

For Multi-Drive mode, where one node can consist of up to 5 drives, refer to [Chapter 7, Using Multi-Drive Mode](#).

Using Logic Command/Status

When enabled, the Logic Command/Status word is always word 0 in the I/O image. The *Logic Command* is a 16-bit word of control produced by the scanner and consumed by the adapter. The *Logic Status* is a 16-bit word of status produced by the adapter and consumed by the scanner.

This manual contains the bit definitions for compatible products available at the time of publication in [Appendix D, Logic Command/Status Words](#). For other products, refer to their documentation.

Using Reference/Feedback

When enabled, Reference/Feedback begins at word 1 in the I/O image. The *Reference* (16 bits) is produced by the controller and consumed by the adapter. The *Feedback* (16 bits) is produced by the adapter and consumed by the controller.

Size	Valid Values ⁽¹⁾	In I/O Image	Example
16-bit	0.0 to 240.0 Hz (PowerFlex 4) or 0.0 to 400.0 Hz (PowerFlex 40)	Word 1	Figure 5.1

⁽¹⁾ The Reference for a PowerFlex 4 or 40 is set in Hz, and not in engineering units like other PowerFlex drives. For example, "300" equates to 30.0 Hz (the decimal point is always implied).

Example Ladder Logic Program

The example ladder logic program works with a ControlLogix controller and a PowerFlex 40 drive.

Function of the Example Program

This example program enables you to:

- Obtain status information from the drive.
- Use the Logic Command to control the drive (for example, start, stop).
- Send a Reference to the drive and receive Feedback from the drive.

Adapter Setting for the Example Program

- Adapter IP address 10. 91. 97. 74 is set using parameters.
- The adapter is configured for Single mode (Operating Mode Switch is set to "Single").

RSLogix 5000 Configuration

Controller Tags

When you add the adapter and drive to the I/O configuration (see [Chapter 4](#)), RSLogix 5000 automatically creates controller tags for them. In this example program, the following controller tags are used.

Figure 5.2 Controller Tags for Example ControlLogix Ladder Logic Program

	P	Tag Name	Type	Description
		PF40_Demo:C	AB:ETHERNET_...	
		PF40_Demo:I	AB:ETHERNET_...	
		PF40_Demo:O	AB:ETHERNET_...	

You can expand the Output and Input tags to reveal the output and input configuration. The Output tag for this example program requires two 16-bit words of data. The Input tag for this example requires four 16-bit words of data. See [Figure 5.3](#).

Figure 5.3 Input/Output Image for Example ControlLogix Ladder Logic Program

	P	Tag Name	Type	Description
		PF40_Demo:C	AB:ETHERNET_...	
		PF40_Demo:I	AB:ETHERNET_...	
		PF40_Demo:I.Data	INT[4]	
		PF40_Demo:I.Data[0]	INT	ENBT Overhead
		PF40_Demo:I.Data[1]	INT	ENBT Overhead
		PF40_Demo:I.Data[2]	INT	PF40 Logic Status
		PF40_Demo:I.Data[3]	INT	PF40 Feedback
		PF40_Demo:O	AB:ETHERNET_...	
		PF40_Demo:O.Data	INT[2]	
		PF40_Demo:O.Data[0]	INT	PF40 Logic Command
		PF40_Demo:O.Data[1]	INT	PF40 Demo Reference

Program Tags

In addition to the Controller tags that are automatically created, you need to create the following Program tags for this example program.

Figure 5.4 Program Tags for Example ControlLogix Ladder Logic Program

	Tag Name	Type	Description
	ClearFault_Command	BOOL	
	Drive_Active	BOOL	PF40 ACTIVE
	Drive_At_Speed	BOOL	PF40 AT SPEED
	Drive_Fault	BOOL	PF40 FAULT
	Drive_Forward	BOOL	PF40 FORWARD
	Drive_Ready	BOOL	PF40 READY
	Drive_Reverse	BOOL	PF40 REVERSE
	Feedback	INT	PF40 Feedback
	Forward_Command	BOOL	
	PerformParameterRead	BOOL	
	PerformParameterWrite	BOOL	
	Reference	INT	
	Start_Command	BOOL	
	Stop_Command	BOOL	

Logic Command/Status Words

This example uses the Logic Command word and Logic Status word for PowerFlex 40 drives. Refer to [Appendix D, Logic Command/Status Words](#) to view these. The definition of the bits in these words may vary if you are using a different DSI product. Refer to the documentation for your product.

Example ControlLogix Ladder Logic Program

Figure 5.5 Example ControlLogix Ladder Logic Program for I/O Messaging

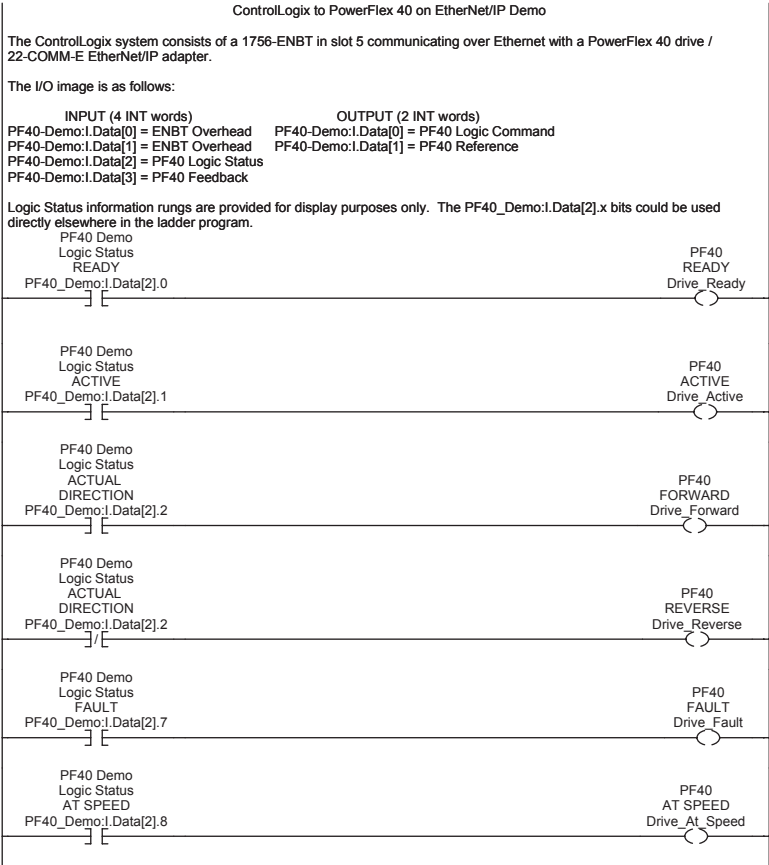
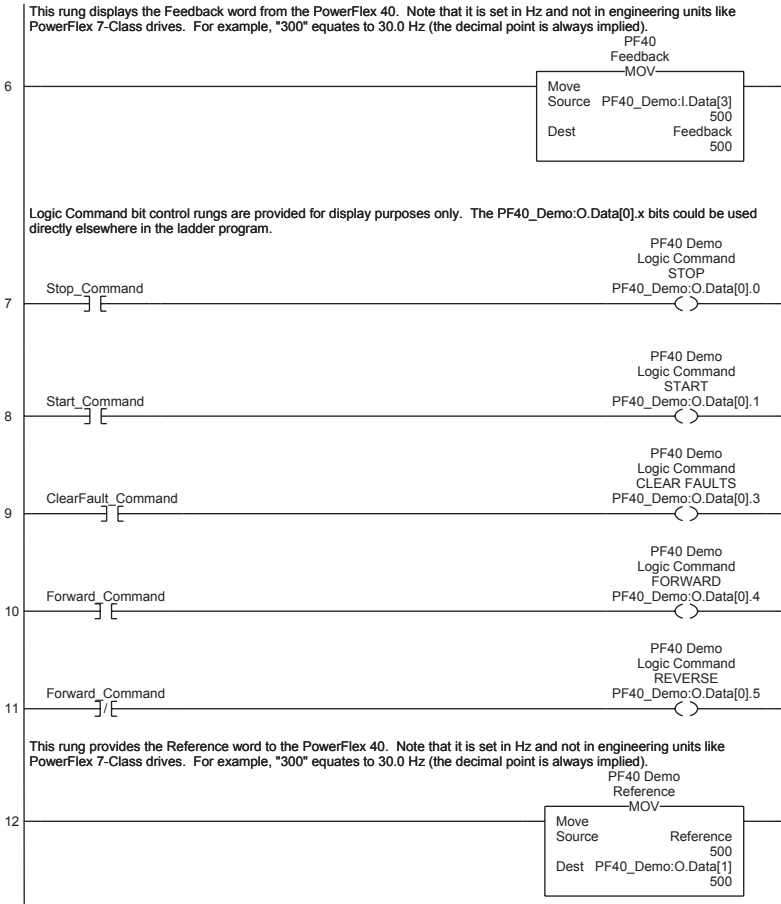

Figure 5.5 Example ControlLogix Ladder Logic Program for I/O Messaging (Cont.)



Using Explicit Messaging

Chapter 6 provides information and examples that explain how to use Explicit Messaging to configure and monitor the EtherNet/IP adapter installed and connected to the PowerFlex 40 drive.

Topic	Page	Topic	Page
About Explicit Messaging	6-1	About the Example Explicit Messages	6-5
Formatting Explicit Messages	6-2	Example Get Attribute Single Message	6-6
Performing Explicit Messages	6-4	Example Set Attribute Single Message	6-8



ATTENTION: Risk of injury or equipment damage exists. The examples in this publication are intended solely for purposes of example. There are many variables and requirements with any application. Rockwell Automation, Inc. does not assume responsibility or liability (to include intellectual property liability) for actual use of the examples shown in this publication.



ATTENTION: Risk of equipment damage exists. If Explicit Messages are programmed to write parameter data to Non-Volatile Storage (NVS) frequently, the NVS will quickly exceed its life cycle and cause the drive to malfunction. Do not create a program that frequently uses Explicit Messages to write parameter data to NVS.

Refer to [Chapter 5](#) for information about the I/O image, using Logic Command/Status and Reference/Feedback.

About Explicit Messaging

Explicit Messaging is used to transfer data that does not require continuous updates. With Explicit Messaging, you can configure and monitor a slave device's parameters on the EtherNet/IP network.

Formatting Explicit Messages

Explicit Messages for the ControlLogix Controller

ControlLogix scanners and bridges accommodate both downloading Explicit Message Requests and uploading Explicit Message Responses. The scanner or bridge module can accommodate one request or response for each transaction block. Each transaction block must be formatted as shown in [Figure 6.1](#).

Figure 6.1 ControlLogix Message Format in RSLogix 5000

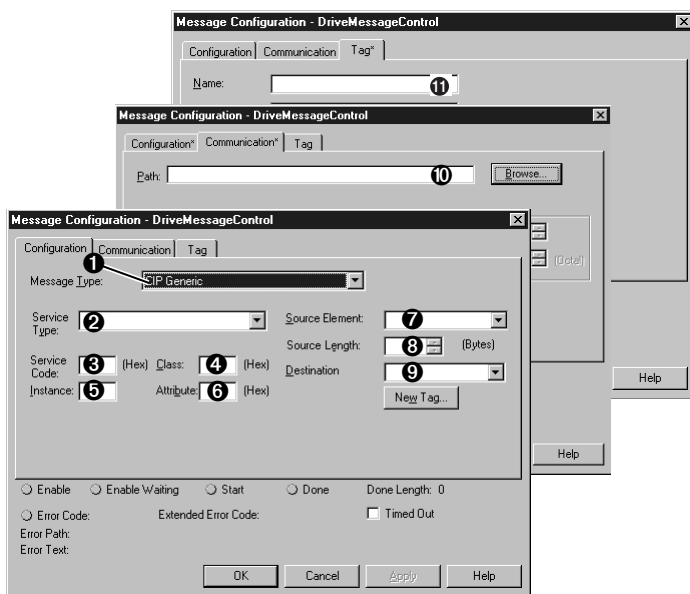

Refer to [page 6-3](#) for a description of the data that is required in each box (1 – 11).



TIP: To display the Message Configuration dialog box in RSLogix 5000, add a message instruction (MSG), create a new tag for the message (properties: Base tag type, MESSAGE data type, controller scope), and click the blue box inside the message.

ControlLogix Message Requests and Responses

Box	Description
1	<p>Message Type</p> <p>The message type must be CIP Generic.</p>
2	<p>Service Type</p> <p>The service type indicates the service (for example, Get Attribute Single or Set Attribute Single) that you want to perform. Available services depend on the class and instance that you are using. Refer to Appendix C, EtherNet/IP Objects.</p>
3	<p>Service Code</p> <p>The service code is the code for the requested EtherNet/IP service. This value changes based on the Service Type that has been selected. In most cases, this is a read-only box. If you select "Custom" in the Service Type box, then you need to specify a service code in this box (for example, 4B for a Get Attributes Scattered service or 4C for a Set Attributes Scattered service).</p>
4	<p>Class</p> <p>The class is an EtherNet/IP class. Refer to Appendix C, EtherNet/IP Objects, for available classes.</p>
5	<p>Instance</p> <p>The instance is an instance (or object) of an EtherNet/IP class. Refer to Appendix C, EtherNet/IP Objects, for available instances for each class.</p>
6	<p>Attribute</p> <p>The attribute is a class or instance attribute. Refer to Appendix C, EtherNet/IP Objects, for available attributes for each class or instance.</p>
7	<p>Source Element</p> <p>This box contains the name of the tag for any service data to be sent from the scanner or bridge to the adapter and drive.</p>
8	<p>Source Length</p> <p>This box contains the number of bytes of service data to be sent in the message.</p>
9	<p>Destination</p> <p>This box contains the name of the tag that will receive service response data from the adapter and drive.</p>
10	<p>Path</p> <p>The path is the route that the message will follow.</p> <p>Tip: Click Browse to find the path or type in the name of an adapter that you previously mapped.</p>
11	<p>Name</p> <p>The name for the message.</p>

Performing Explicit Messages

There are five basic events in the Explicit Messaging process. The details of each step will vary depending on the controller. Refer to the documentation for your controller.

Figure 6.2 Explicit Message Process

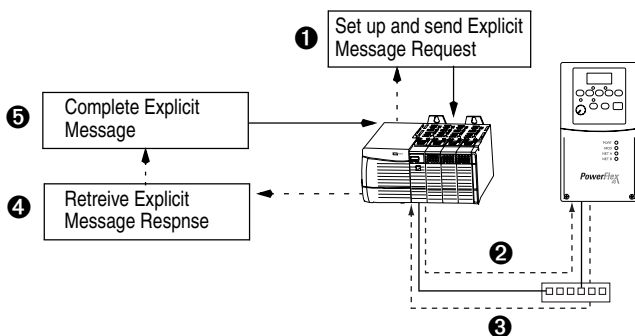

Event

1. You format the required data and set up the ladder logic program to send an Explicit Message request to the scanner or bridge module (download).
2. The scanner or bridge module transmits the Explicit Message Request to the slave device over the Ethernet network.
3. The slave device transmits the Explicit Message Response back to the scanner. The data is stored in the scanner buffer.
4. The controller retrieves the Explicit Message Response from the scanner's buffer (upload).
5. The Explicit Message is complete.

About the Example Explicit Messages

These examples show how to format and execute the following types of Explicit Messages using a ControlLogix controller:

- Get Attribute Single
- Set Attribute Single

Message Formats

When formatting an example message, refer to [Formatting Explicit Messages](#) in this chapter for an explanation of the content of each box.

Also, to format and execute these example messages, you need the Controller tags displayed in [Figure 6.3](#).

Figure 6.3 Controller Tags for Explicit Messages

Scope: EtherNet/IP_Demo(c)		Shgw: Show All	Sort: Tag Name
P	Tag Name	Type	Description
▶	ParameterReadMessage	MESSAGE	
	ParameterReadValue	INT	
	ParameterWriteMessage	MESSAGE	
	ParameterWriteValue	INT	
	PF40_Demo:C	AB:ETHERNET_...	
	PF40_Demo:I	AB:ETHERNET_...	
	PF40_Demo:O	AB:ETHERNET_...	

Ladder Logic Rungs

The ladder logic rungs for the examples in this chapter can be appended after rung 12 in the ladder logic program ([Figure 5.5](#)) in [Chapter 5, Using I/O Messaging](#).

Source and Destination Data

The example values for the source and destination data that appear in this chapter may vary in your application.

Example Get Attribute Single Message

A Get Attribute Single message reads a single attribute value. In this example, we read the value of a parameter in a PowerFlex 40 drive.

Example Message Format

Figure 6.4 Message Format for a Get Attribute Single Message

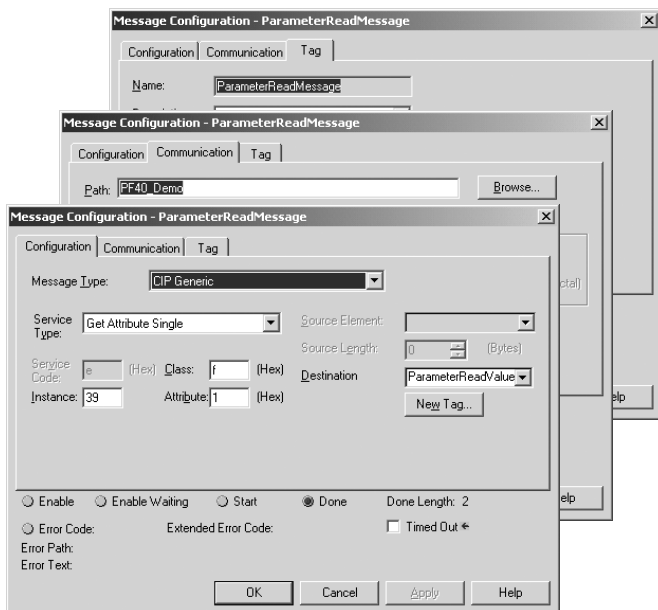

The following table identifies key settings for the message format:

Configuration	Value	Description	Refer to . . .
Service Type ⁽¹⁾	Get Attribute Single	Read parameter data	C-27
Service Code ⁽¹⁾	e (Hex.)	Get_Attribute_Single	C-12
Class	f (Hex.)	DSI Parameter Object	C-24
Instance	39 (Dec.)	Parameter 39 - [Accel Time 1]	C-24
Attribute	1 (Hex.)	Parameter Value	C-25
Destination	ParameterReadValue	Controller tag for response data	—

⁽¹⁾ The default setting for Service Type is “Custom,” which enables you to enter a Service Code that is not available from the Service Type pulldown menu. When you select a Service Type other than “Custom” from the pulldown menu, an appropriate Hex. value is automatically assigned to the Service Code box which grays out (unavailable).

Example Ladder Logic Rung

Figure 6.5 Example Get Attribute Single Message

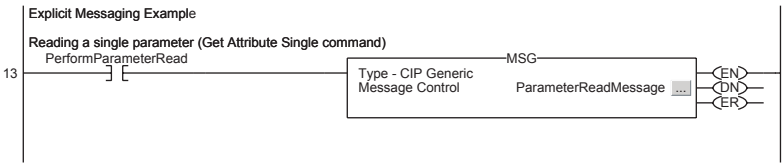

Example Destination Data

In this example, the Get Attribute Single message reads **Parameter 39 - [Accel Time 1]** in the PowerFlex 40 drive and returns its value to the destination tag named ParameterReadValue.

Figure 6.6 Example Destination Data from a Get Attribute Single Message

ParameterReadValue	100	Decimal	INT
--------------------	-----	---------	-----

The acceleration time is 10.0 seconds.

Example Set Attribute Single Message

A Set Attribute Single message writes a value for a single attribute. In this example, we write the value of a parameter in a PowerFlex 40 drive.

Example Message Format

Figure 6.7 Message Format for a Set Attribute Single Message

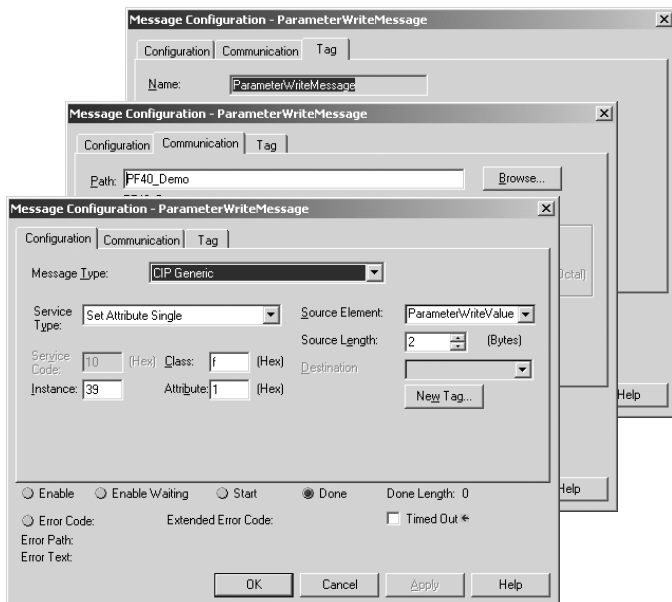

The following table identifies key settings for the data format:

Configuration	Value	Description	Refer to . . .
Service Type ⁽¹⁾	Set Attribute Single	Write parameter data	C-27
Service Code ⁽¹⁾	10 (Hex.)	Set_Attribute_Single	C-12
Class	f (Hex.)	DSI Parameter Object	C-24
Instance	39 (Dec.)	Parameter 39 - [Accel Time 1]	C-24
Attribute	1 (Hex.)	Parameter Value	C-25
Source Element	ParameterWriteValue	Controller tag for write data	—
Source Length	2 bytes	One 16-bit word of data is sent	—

⁽¹⁾ The default setting for Service Type is “Custom,” which enables you to enter a Service Code that is not available from the Service Type pulldown menu. When you select a Service Type other than “Custom” from the pulldown menu, an appropriate Hex. value is automatically assigned to the Service Code box which grays out (unavailable).

Example Ladder Logic Rung

Figure 6.8 Example Set Attribute Single Message

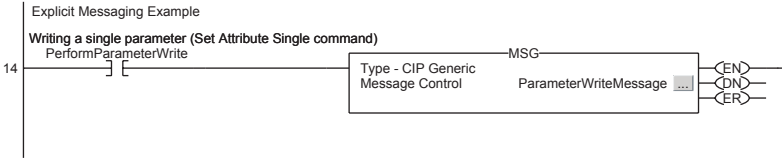

Example Source Data

In this example, the Set Attribute Single message writes 100, the value in the source tag named ParameterWriteValue, to **Parameter 39 - [Accel Time 1]** in the PowerFlex 40 drive.

Figure 6.9 Example Source Data from a Set Attribute Single Message

+	ParameterWriteValue	100	Decimal	INT
---	---------------------	-----	---------	-----

10.0 seconds is written to the parameter.

Notes:

Using Multi-Drive Mode

Chapter 7 provides information and a ControlLogix ladder example to explain how to use Multi-Drive mode.

Topic	Page	Topic	Page
Single Mode vs. Multi-Drive Mode	7-1	Multi-Drive Ladder Logic Program Example	7-6
System Wiring	7-3	ControlLogix Example	7-7
Understanding the I/O Image	7-4	Multi-Drive Mode Explicit Messaging	7-20
Configuring the RS-485 Network	7-5	Additional Information	7-22



ATTENTION: Risk of injury or equipment damage exists. The examples in this publication are intended solely for purposes of example. There are many variables and requirements with any application. Rockwell Automation, Inc. does not assume responsibility or liability (to include intellectual property liability) for actual use of the examples shown in this publication.

Single Mode vs. Multi-Drive Mode

Single mode is a typical network installation, where a single EtherNet/IP node consists of a single drive with a 22-COMM-E adapter ([Figure 7.1](#)).

Figure 7.1 Single Mode Example for Network

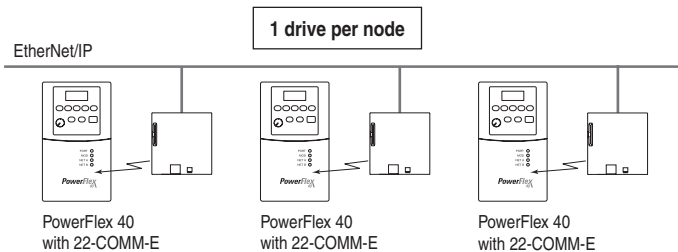

Multi-Drive mode is an alternative to the typical network installation, where a single EtherNet/IP node can consist of one to five drives ([Figure 7.2](#)). The first drive must be a PowerFlex 40 with a 22-COMM-E adapter. The remaining drives can be PowerFlex 4 or PowerFlex 40 drives that are daisy-chained over RS-485 with the first drive.

Figure 7.2 Multi-Drive Mode Example for Network

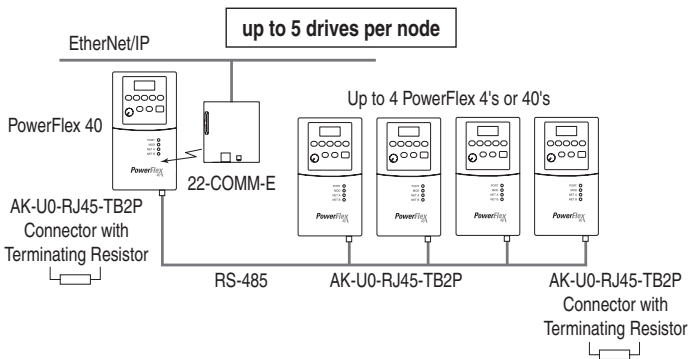

Benefits of Multi-Drive mode include:

- Lower hardware costs. Only one 22-COMM-E adapter is needed for up to five drives. PowerFlex 4's can also be used for the daisy-chained drives instead of PowerFlex 40's.
- Reduces the network node count. For example, in Single mode 30 drives would consume 30 nodes. In Multi-Drive mode, 30 drives can be connected in 6 nodes.
- Provides a means to put PowerFlex 4's on EtherNet/IP (PowerFlex 4's do not have an internal communications adapter slot).
- Controller can control, monitor, and read/write parameters for all five drives.

The trade-offs of Multi-Drive mode include:

- If the PowerFlex 40 with the 22-COMM-E adapter is powered down, then communications with the daisy-chained drives is disrupted and the drives will take the appropriate communications loss action set in each drive.
- Communications throughput to the daisy-chained drives will be slower than if each drive was a separate node on EtherNet/IP (Single mode). This is because the 22-COMM-E adapter must take the EtherNet/IP data for the other drives and sequentially send the respective data to each drive over RS-485. The approximate additional throughput time for Logic Command/Reference to be transmitted and received by each drive is:

Drive	Additional Throughput Time versus Single Mode
PowerFlex 40 with 22-COMM-E	0 ms
PowerFlex 40 with 22-COMM-E plus 1 drive	+24 ms
PowerFlex 40 with 22-COMM-E plus 2 drives	+48 ms
PowerFlex 40 with 22-COMM-E plus 3 drives	+72 ms
PowerFlex 40 with 22-COMM-E plus 4 drives	+96 ms

- Since the RS-485 ports are used for daisy-chaining the drives, there is no connection for a peripheral device such as a HIM. The AK-U0-RJ45-SC1 DSI Splitter cable cannot be used to add a second connection for a peripheral device.

System Wiring

To daisy-chain the drives off the PowerFlex 40 with the 22-COMM-E adapter (Drive 0), the AK-U0-RJ45-TB2P terminal block connector (Figure 7.3) can be used for easy installation.

Figure 7.3 AK-U0-RJ45-TB2P Terminal Block Connector



The wiring diagram for using AK-U0-RJ45-TB2P terminal block connectors is shown in Figure 7.4.

Figure 7.4 AK-U0-RJ45-TB2P Connector Wiring Diagram

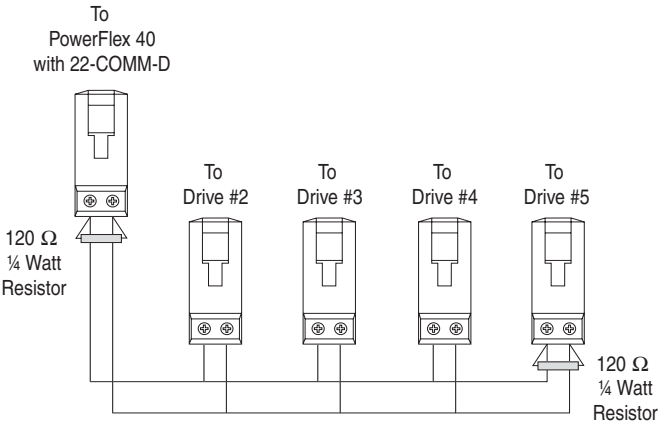

The AK-U0-RJ45-TB2P comes with (5) terminal block connectors and (2) terminating resistors.

Understanding the I/O Image

The terms *input* and *output* are defined from the scanner's point of view. Therefore, Output I/O is data that is output from the scanner and consumed by the EtherNet/IP adapter. Input I/O is status data that is produced by the adapter and consumed as input by the scanner. The I/O image table will vary based on the:

- Configuration of the Operating Mode Switch (SW1) on the adapter and **Parameter 22 - [DSI I/O Cfg]**. The image table always uses consecutive words starting at word 0.

[Figure 7.5](#) illustrates the Multi-Drive I/O image with 16-bit words.

Figure 7.5 Multi-Drive Example of I/O Image

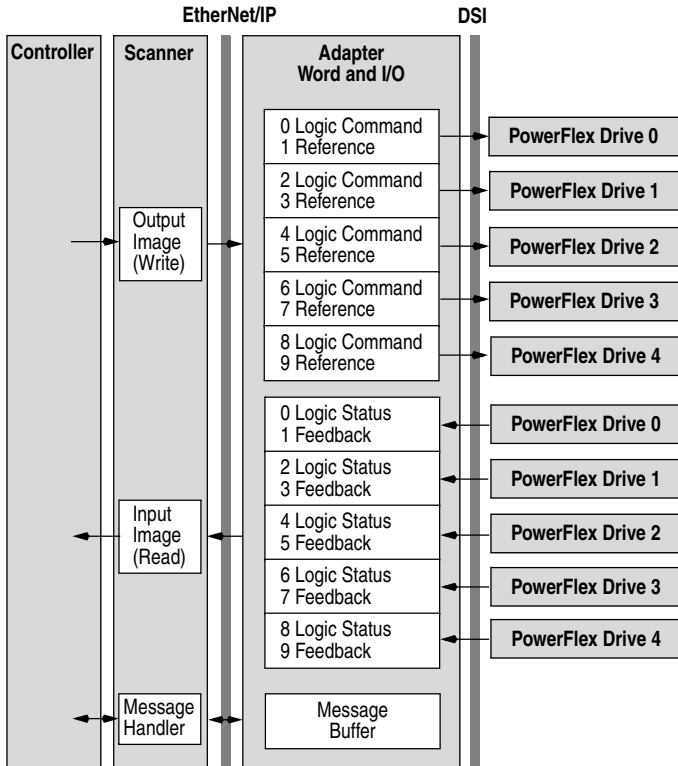

Note: If a daisy-chained drive is disconnected from the RS-485 (DSI) network or powered down, the Logic Status and Feedback words for the affected drive will be set to 0.

Configuring the RS-485 Network

The following parameters must be set in the daisy-chained drives:

Parameter	Value
P36 - [Start Source]	5 (Comm Port)
P38 - [Speed Reference]	5 (Comm Port)
A103 - [Comm Data Rate]	4 ("19.2K")
A104 - [Comm Node Addr]	1-247 (must be unique)
A107 - [Comm Format]	0 ("RTU 8-N-1")

Note that the RS-485 network is fixed at 19.2K baud, 8 data bits, no parity, and 1 stop bit.

Important: Parameters **A105 - [Comm Loss Action]** and **A106 - [Comm Loss Time]** in the daisy-chained drives are still used in Multi-Drive mode. If the RS-485 cable is disconnected or broken, the disconnected drive(s) will take the corresponding Comm Loss Action(s). On the EtherNet/IP side, **Parameters 18 - [Comm Flt Action]** and **19 - [Idle Flt Action]** in the 22-COMM-E determine the action taken for ALL of the drives on the Multi-Drive node.

The following Multi-Drive parameters must be set in the 22-COMM-E:

Parameter	Value
22 - [DSI I/O Cfg]	0 = Drive 0 connected 1 = Drives 0-1 connected 2 = Drives 0-2 connected 3 = Drives 0-3 connected 4 = Drives 0-4 connected
24 - [Drv 0 Addr]	= Parameter A104 - [Comm Node Address] in Drive 0
25 - [Drv 1 Addr]	= Parameter A104 - [Comm Node Address] in Drive 1
26 - [Drv 2 Addr]	= Parameter A104 - [Comm Node Address] in Drive 2
27 - [Drv 3 Addr]	= Parameter A104 - [Comm Node Address] in Drive 3
28 - [Drv 4 Addr]	= Parameter A104 - [Comm Node Address] in Drive 4

After setting the 22-COMM-E parameters, set the Operating Mode Switch (SW1) from Single drive operation to Multi-Drive operation (set to ON position), and reset the adapter or cycle power. Refer to [Chapter 2, Setting Operating Mode and Web Pages Switches](#).

Important: 22-COMM-E parameters can be set using a DSI peripheral (HIM, DriveExplorer with 22-SCM-232, etc.) ONLY when the Operating Mode Switch is in the Single mode position (SW1 = OFF).

Multi-Drive Ladder Logic Program Example

The example ladder logic program demonstrates using Multi-Drive mode with five drives. See [Figure 7.2](#) for a system layout diagram.

Function of the Example Program

The example program provided is for the ControlLogix, but other controllers can also be used. This example program enables you to:

- View status information from the drives such as Ready, Fault, At Speed, and Feedback.
- Control the drives using various Logic Command bits (Stop, Start, etc.) and Reference.
- Perform a single parameter read and write for each drive. The example uses drive **Parameter 39 - [Accel Time]** for both so you can see (read) the change after a write is performed.

Adapter Settings for the Example Program

- The Operating Mode Switch (SW1) on the adapter is set to the Multi-Drive operation position. See [Chapter 2, Setting Operating Mode and Web Pages Switches](#).
- The following adapter parameters are set:

Parameter	Value	Description
22 - [DSI I/O Cfg]	4	"Drives 0-4" — 5 drives on 1 node
24 - [Drv 0 Addr] ⁽¹⁾	1	Modbus address of Drive 0
25 - [Drv 1 Addr] ⁽¹⁾	2	Modbus address of Drive 1
26 - [Drv 2 Addr] ⁽¹⁾	3	Modbus address of Drive 2
27 - [Drv 3 Addr] ⁽¹⁾	4	Modbus address of Drive 3
28 - [Drv 4 Addr] ⁽¹⁾	5	Modbus address of Drive 4

⁽¹⁾ The settings for these parameters must match the Parameter A104 - [Comm Node Addr] settings in the respective drives.

Drive Settings for the Example Program

Parameter	Value				
	Drive 0	Drive 1	Drive 2	Drive 3	Drive 4
P36 - [Start Source]	5	5	5	5	5
P38 - [Speed Reference]	5	5	5	5	5
A103 - [Comm Data Rate]	4	4	4	4	4
A104 - [Comm Node Addr] ⁽¹⁾	1	2	3	4	5
A105 - [Comm Loss Action]	0	0	0	0	0
A106 - [Comm Loss Time]	5	5	5	5	5
A107 - [Comm Format]	0	0	0	0	0

⁽¹⁾ The settings for these parameters must match the respective parameter settings in the adapter (Parameter 17 - [Drv 0 Addr] through Parameter 21 - [Drv 4 Addr]).

ControlLogix Example

The following common Tags are used:

Tag Name	Type	Description
MultiDrive_Demo : I	AB: 1756_E...	1756-ENBT I/O
MultiDrive_Demo : O	AB: 1756_E...	
MultiDrive_Demo : C	AB: 1756_E...	
Drive Input Image	INT [10]	Input Image Table
Drive Output Image	INT [10]	Output Image Table

The following Tags are used for Drive 0:

Tag Name	Type	Description
Drive 0 Command Stop	BOOL	Logic Command bit 0 (STOP)
Drive 0 Command Start	BOOL	Logic Command bit 1 (START)
Drive 0 Command Jog	BOOL	Logic Command bit 2 (JOG)
Drive 0 Command Clear Faults	BOOL	Logic Command bit 3 (CLEAR FAULTS)
Drive 0 Command Forward	BOOL	Logic Command bit 4 (FORWARD)
Drive 0 Reference	INT	Speed Reference
Drive 0 Status Ready	BOOL	Logic Status bit 0 (READY)
Drive 0 Status Active	BOOL	Logic Status bit 1 (ACTIVE)
Drive 0 Status Forward	BOOL	Logic Status bit 3 (FORWARD)
Drive 0 Status Faulted	BOOL	Logic Status bit 7 (FAULT)
Drive 0 Status At Reference	BOOL	Logic Status bit 8 (AT SPEED)
Drive 0 Feedback	INT	Speed Feedback
Perform Parameter Read 0	BOOL	Initiates the parameter read
Parameter RD Value 0	INT	Read value of the parameter
Parameter RD Message 0	MESSAGE	Get_Attribute_Single (Read)

Tag Name	Type	Description
Perform Parameter Write 0	BOOL	Initiates the parameter value
Parameter WR Value 0	INT	Write value to the parameter
Parameter WR Message 0	MESSAGE	Set_Attribute_Single (Write)

The same type of Tags are also used for Drive 1 through Drive 4.

Main Routine

The Main Routine reads the network Input Image from the scanner, calls the various drive control subroutines, and writes the network Output Image to the scanner. See [Figure 7.6](#).

Figure 7.6 Main Routine

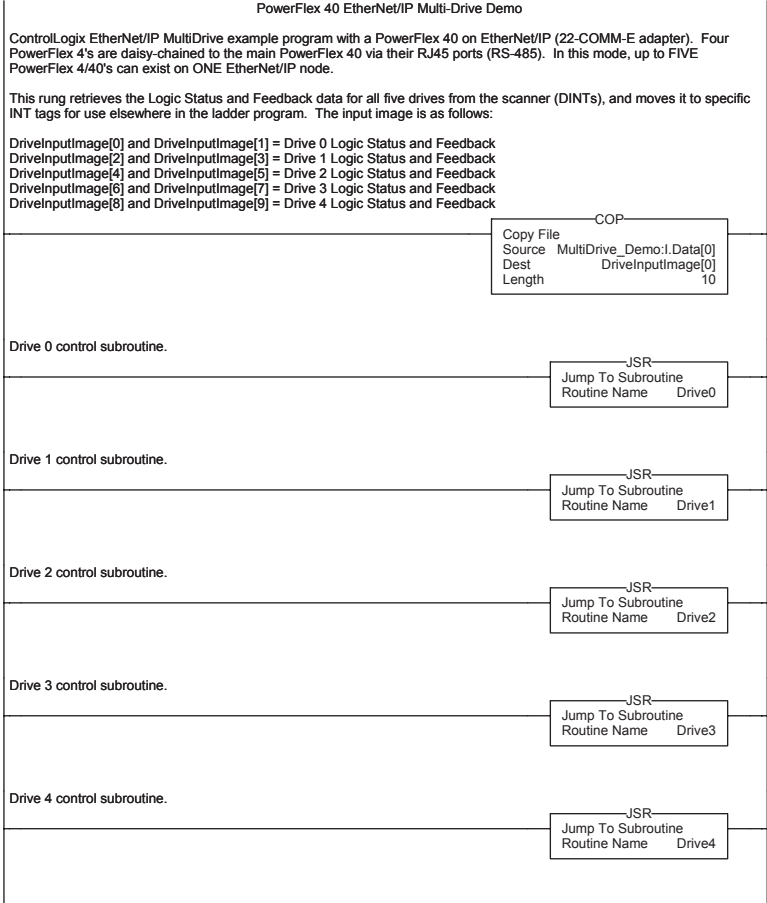
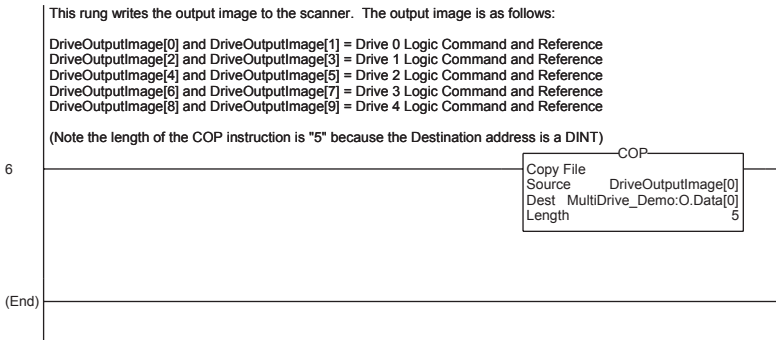

Figure 7.6 Main Routine (Continued)



Drive 0 - Drive 4 Control Routines

The following Drive Control routines provide status information (Logic Status and Feedback), control (Logic Command and Reference), and parameter read/write for each of the respective drives:

Control Routine	Refer to . . .
Drive 0	Figure 7.7
Drive 1	Figure 7.8
Drive 2	Figure 7.9
Drive 3	Figure 7.10
Drive 4	Figure 7.11

Figure 7.7 Drive 0 Control Routine

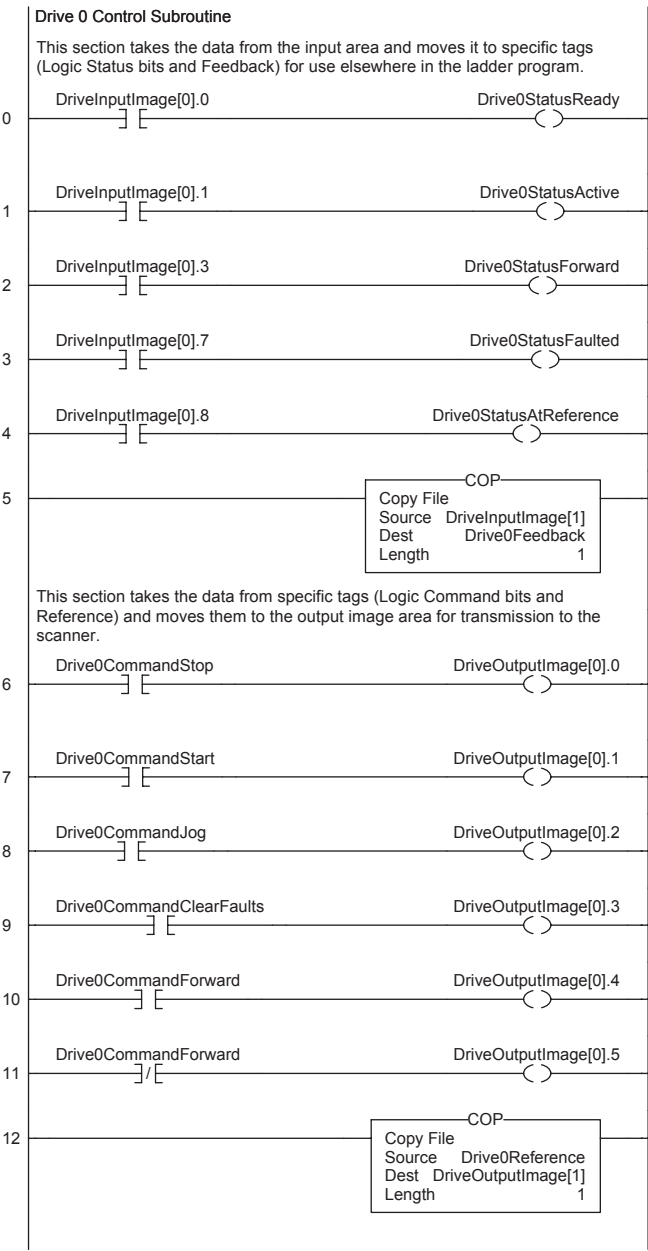

Figure 7.7 Drive 0 Control Routine (Continued)

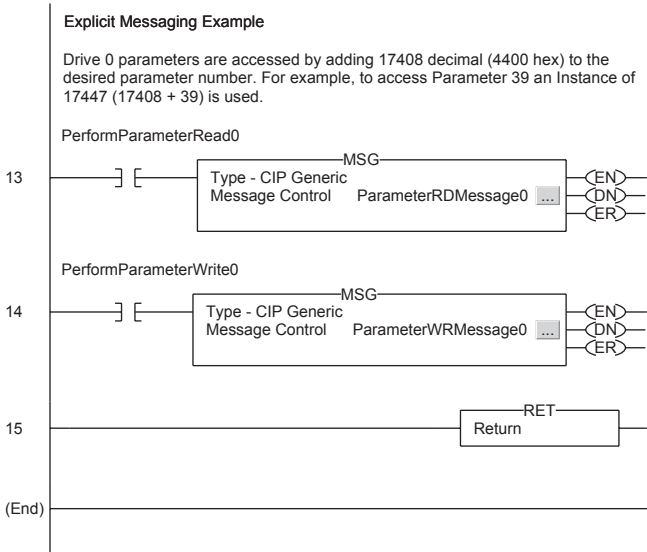

Figure 7.8 Drive 1 Control Routine

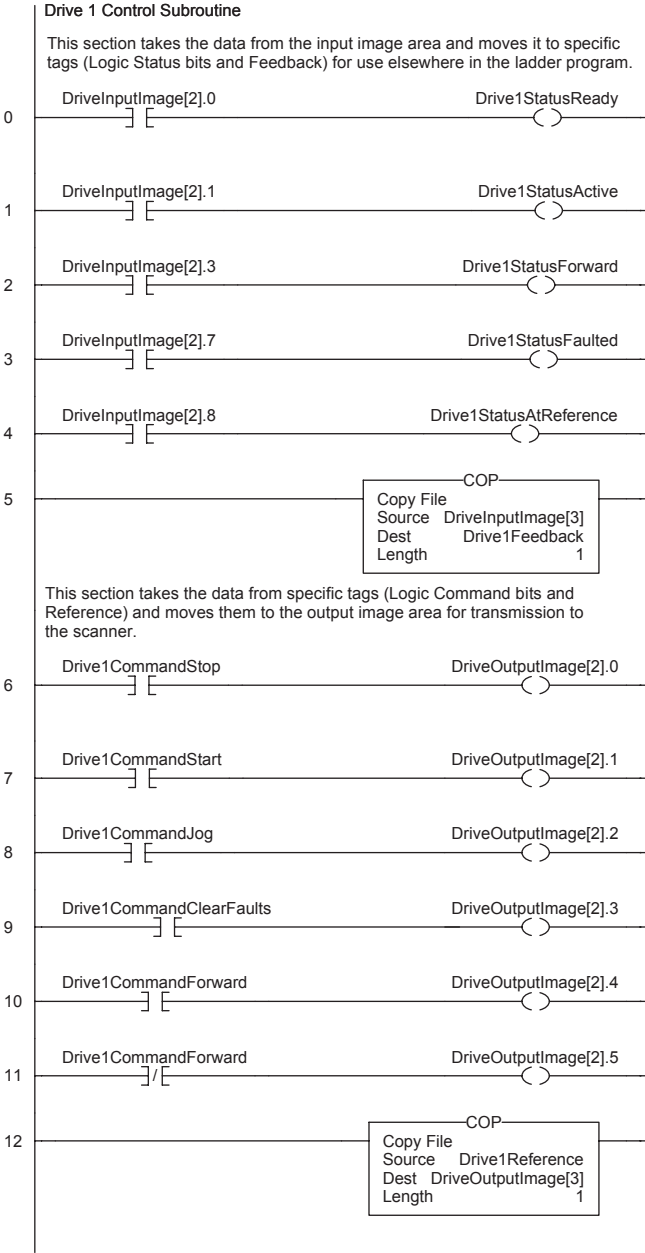

Figure 7.8 Drive 1 Control Routine (Continued)

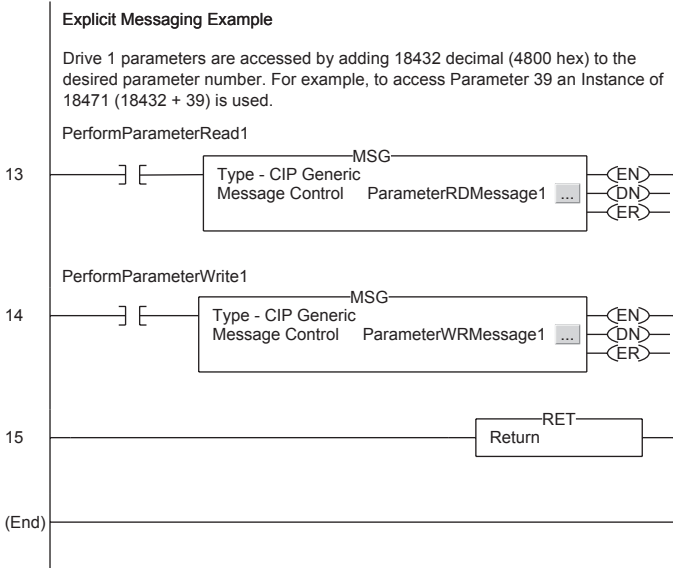

Figure 7.9 Drive 2 Control Routine

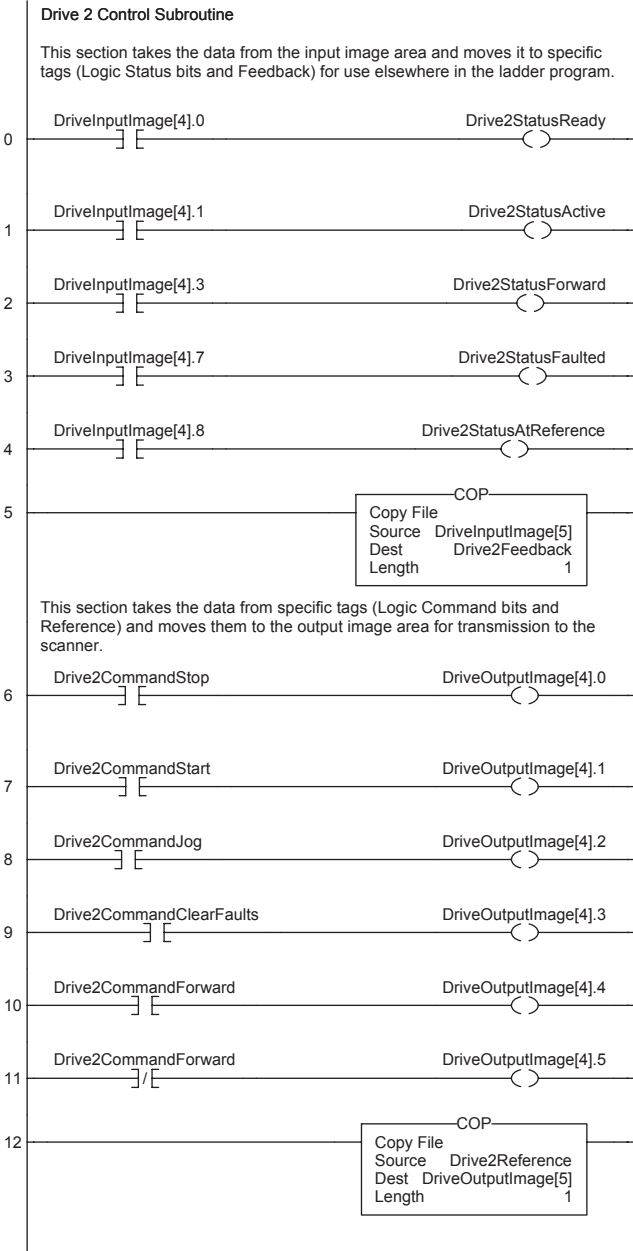

Figure 7.9 Drive 2 Control Routine (Continued)

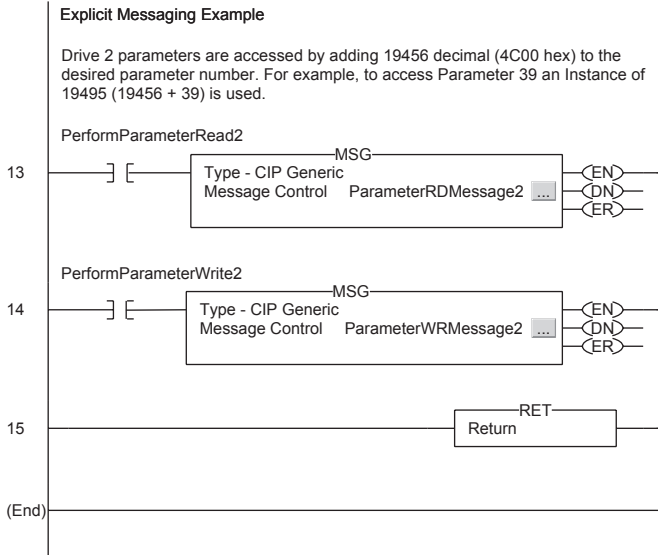

Figure 7.10 Drive 3 Control Routine

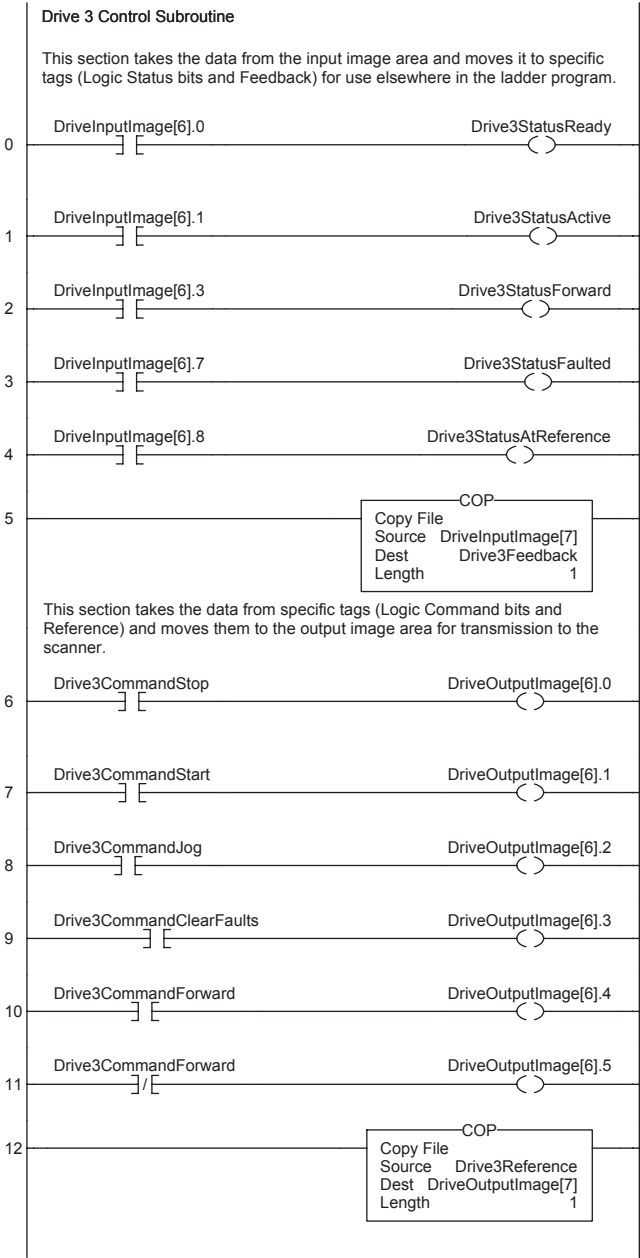

Figure 7.10 Drive 3 Control Routine (Continued)

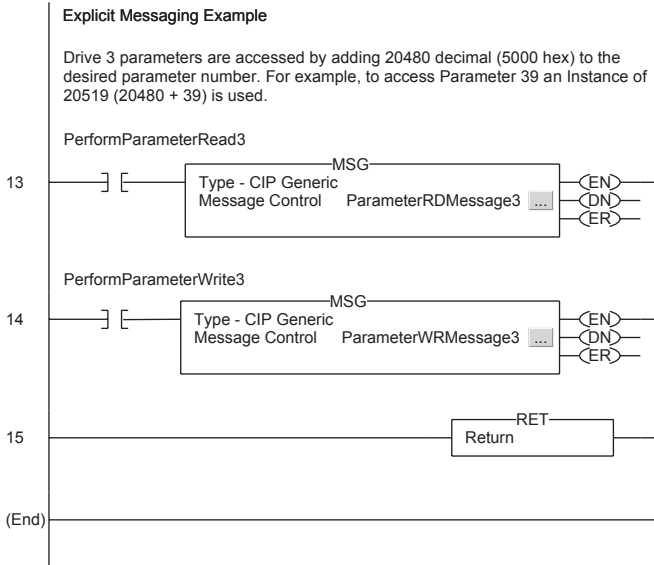

Figure 7.11 Drive 4 Control Routine

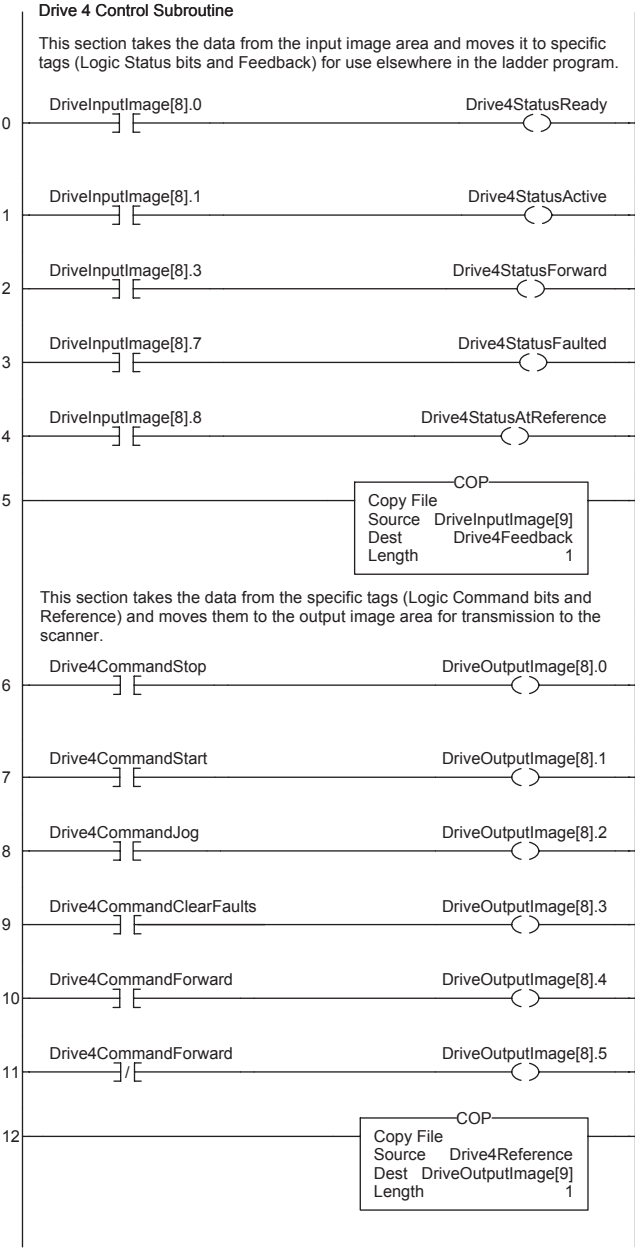
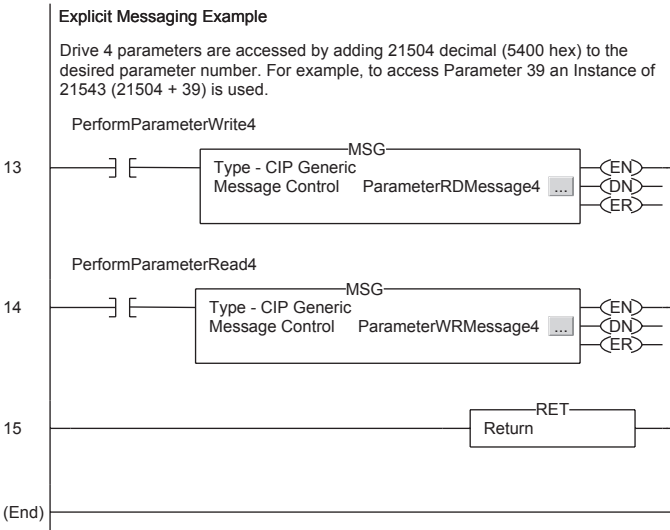

Figure 7.11 Drive 4 Control Routine (Continued)



Multi-Drive Mode Explicit Messaging

Parameter addressing for Explicit messaging is different in Multi-Drive than with Single mode. In Single mode, the Instance value in the message equals the desired parameter number in the drive. In Multi-Drive mode, an Instance table is used to account for the parameters in the adapter and up to 5 drives. The parameters in the adapter and each of the drives are offset by 400 hex (1024 decimal):

Instance (Hex.)	(Dec.)	Device	Parameter
4000 - 43FF	16384 - 17407	22-COMM-E	0 - 1023
4400 - 47FF	17408 - 18431	Drive 0	0 - 1023
4800 - 4BFF	18432 - 19455	Drive 1	0 - 1023
4C00 - 4FFF	19456 - 20479	Drive 2	0 - 1023
5000 - 53FF	20480 - 21503	Drive 3	0 - 1023
5400 - 57FF	21504 - 22527	Drive 4	0 - 1023

For example, to access **Parameter P39 - [Accel Time 1]** in each of the drives, the following Instances would be used:

- Drive 0 Instance = 17447 (17408 + 39)
- Drive 1 Instance = 18471 (18432 + 39)
- Drive 2 Instance = 19495 (19456 + 39)
- Drive 3 Instance = 20519 (20480 + 39)
- Drive 4 Instance = 21543 (21504 + 39)

Drive 0 Explicit Message Example

The Explicit message examples in the ControlLogix example program perform a read (Get_Attribute_Single) and a write (Set_Attribute_Single) to **Parameter 39 - [Accel Time 1]**. The configuration for the read is shown in [Figure 7.12](#) and the write is shown in [Figure 7.13](#).

Figure 7.12 Parameter Read Message Configuration

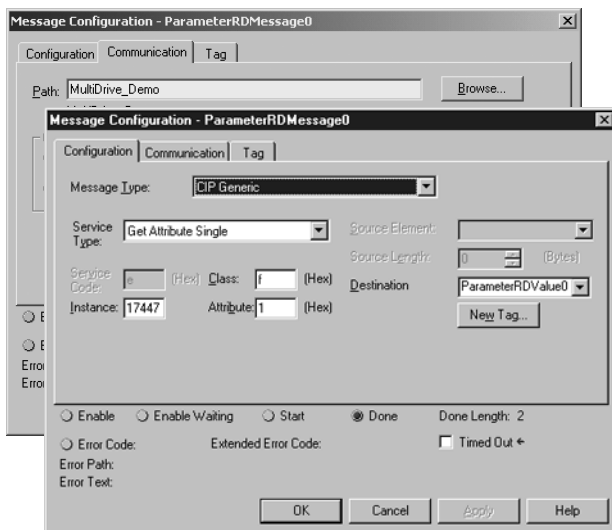
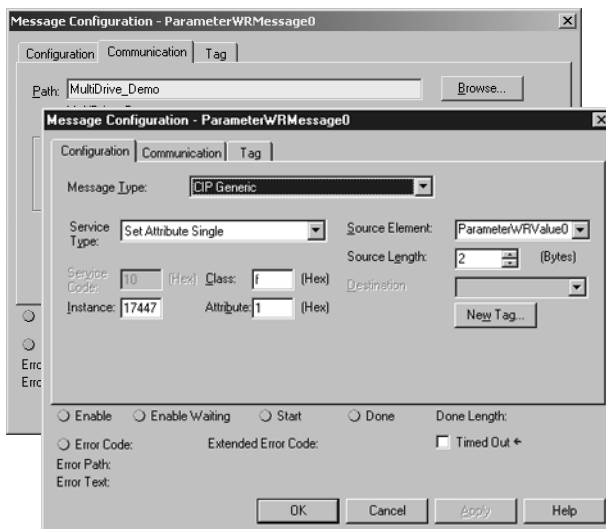

Figure 7.13 Parameter Write Message Configuration



The Class Code is “f” for the Parameter Object and the Instance Attribute is “1” to select retrieving the parameter value. See [Appendix C, Parameter Object](#) for more information. The Instance value is “17447” to access **Parameter 39 - [Accel Time 1]**.

The Explicit messages for Drive 1 to Drive 4 are identical except for the Instance values:

Drive 1 Instance = 18471 (18432 + 39)

Drive 2 Instance = 19495 (19456 + 39)

Drive 3 Instance = 20519 (20480 + 39)

Drive 4 Instance = 21543 (21504 + 39)

Additional Information

- When the PowerFlex 40 with the 22-COMM-E (Drive 0) is powered up, all configured daisy-chained drives must be present before an I/O connection is allowed on EtherNet/IP (i.e. before the drives can be controlled).
- If the PowerFlex 40 with the 22-COMM-E adapter (Drive 0) is powered down, communications with the four daisy-chained drives (Drive 1 to Drive 4) are disrupted and the drives will take their corresponding Comm Loss Actions.
- If any of the daisy-chained drives (Drive 1 to Drive 4) are powered down, the respective Input Image (Logic Status and Feedback) sent to the scanner will be zeros, and the NET A and PORT LEDs on the 22-COMM-E adapter will flash red. Status information from the scanner will not indicate there is a fault at the node, and the I/O connection will not be dropped.

Troubleshooting

Chapter 8 provides information for troubleshooting potential problems with the adapter.

Topic	Page	Topic	Page
Locating the Status Indicators	8-1	Adapter Diagnostic Items in Single Drive Mode	8-5
PORT Status Indicator	8-2	Adapter Diagnostic Items in Multi-Drive Mode	8-7
MOD Status Indicator	8-3	Viewing and Clearing Events	8-8
Net A Status Indicator	8-4		

Locating the Status Indicators

The EtherNet/IP adapter has four status indicators. They can be viewed on the adapter or through the drive cover. See [Figure 8.1](#).

Figure 8.1 Status Indicators (*location on drive may vary*)

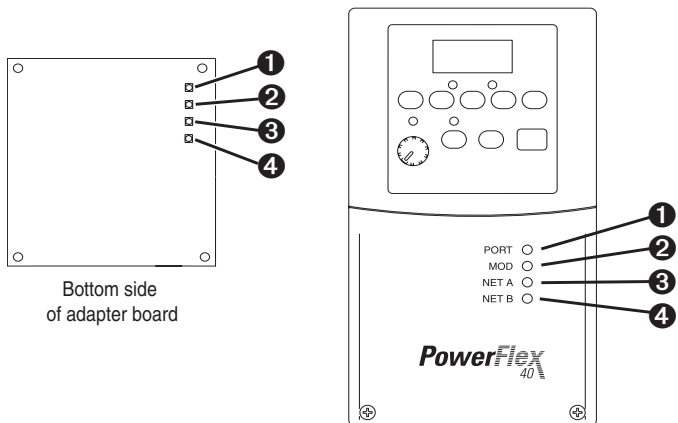

Item	Status Indicator	Description	Page
①	PORT	DSI Connection Status	8-2
②	MOD	Adapter Status	8-3
③	NET A	EtherNet/IP Connection Status	8-4
④	NET B	EtherNet/IP Transmit Status	8-5

PORT Status Indicator

Status	Cause	Corrective Action
Off	The adapter is not powered or properly connected to the drive.	<ul style="list-style-type: none"> Securely connect the adapter to the drive using the Internal Interface (ribbon) cable. Apply power to the drive.
Flashing Red	<p>In Single mode, the adapter is not receiving communication from the drive.</p> <p>In Multi-Drive mode, the adapter is not receiving communication from a drive, or a drive is not an Allen-Bradley drive.</p>	<ul style="list-style-type: none"> Verify the setting for Parameter 22 - [DSI I/O Cfg]. Verify that cables are securely connected and not damaged. Replace cables if necessary. Cycle power to the drive. Use Allen-Bradley PowerFlex 4/40 drives.
Flashing Green	The adapter is establishing communications with the drive.	No action required. This status indicator will turn solid green or flashing red.
Solid Green	The adapter is properly connected and is communicating with the drive.	No action required.
Orange	In Single mode, the drive is not an Allen-Bradley drive.	Use an Allen-Bradley PowerFlex 40 drive.

MOD Status Indicator

Status	Cause	Corrective Action
Off	The adapter is not powered or properly connected to the drive.	<ul style="list-style-type: none"> Securely connect the adapter to the drive using the Internal Interface (ribbon) cable. Apply power to the drive.
Flashing Red	The adapter has failed the firmware test.	<ul style="list-style-type: none"> Cycle power to the drive. If cycling power does not correct the problem, the adapter parameter settings may have been corrupted. Reset defaults and reconfigure the adapter. If resetting defaults does not correct the problem, flash the adapter with the latest firmware release.
Solid Red	The adapter has failed the hardware test.	<ul style="list-style-type: none"> Cycle power to the drive. Replace the adapter.
Flashing Green	The adapter is operational, but is not transferring I/O data.	<ul style="list-style-type: none"> Place the scanner in RUN mode. Program the controller to recognize and transmit I/O to the adapter. Configure the adapter for the program in the controller.
Solid Green	The adapter is operational and transferring I/O data.	No action required.

Net A Status Indicator

Status	Cause	Corrective Actions
Off	The adapter and/or network is not powered, the adapter is not properly connected to the network, or the adapter needs an IP address.	<ul style="list-style-type: none"> Securely connect the adapter to the drive using the Internal Interface (ribbon) cable and to the network using an Ethernet cable. Correctly connect the Ethernet cable to the Ethernet connector. Set a unique IP address using a BOOTP server or by disabling BOOTP and using adapter parameters. Apply power to the drive and network.
Flashing Red	An EtherNet/IP connection has timed out.	<ul style="list-style-type: none"> Place the scanner in RUN mode. Check the amount of traffic on the network.
Solid Red	The adapter failed the duplicate IP address detection test.	Configure the adapter to use a unique IP address and cycle power.
Flashing Green	The adapter is properly connected but is not communicating with any devices on the network.	<ul style="list-style-type: none"> Place the controller in RUN mode. Program the controller to recognize and transmit I/O or make a messaging connection to the adapter. Configure the adapter for the program in the controller.
Solid Green	The adapter is properly connected and communicating on the network.	No action required.

Net B Status Indicator

Status	Cause	Corrective Actions
Off	The adapter is not powered, or is not transmitting on the network.	<p>If Net A indicator is off:</p> <ul style="list-style-type: none"> Securely connect the adapter to the drive using the Internal Interface (ribbon) cable and to the network using an Ethernet cable. Correctly connect the Ethernet cable to the Ethernet connector. Set a unique IP address using a BOOTP server or by disabling BOOTP and using adapter parameters. <p>If Net A indicator is solid red:</p> <ul style="list-style-type: none"> Configure the adapter to use a unique IP address and cycle power. <p>If Net A indicator is flashing red:</p> <ul style="list-style-type: none"> Check the IP address in the adapter and scanner. Ping the adapter. <p>Normal condition if the adapter is idle.</p>
Flashing Green	The adapter is transmitting on the network.	No action required.

Adapter Diagnostic Items in Single Drive Mode

The following diagnostic items can be accessed using DriveExplorer (version 3.01 or higher).

No.	Name	Description
1	Reserved	
2	Logic Cmd	Logic Command being transmitted to the drive by the adapter.
3	Reference	Reference being transmitted to the drive by the adapter.
4	Reserved	
5	Logic Sts	Logic Status being received from the drive by the adapter.
6	Feedback	Feedback being received from the drive by the adapter.
7-22	Reserved	
23	DSI Overrun Errs	The number of DSI receive overrun errors.
24	DSI Framing Errs	The number of DSI receive framing errors.
25	DSI CRC Errs	The number of DSI receive CRC errors.

No.	Name	Description
26	Boot Flash Count	Number of boot firmware flash updates made to the adapter after shipping.
27	App Flash Count	Number of application firmware flash updates made to the adapter after shipping.
28	HW Addr 1	The most significant byte in the adapter's Ethernet MAC address.
29	HW Addr 2	The second most significant byte in the adapter's Ethernet MAC address.
30	HW Addr 3	The third most significant byte in the adapter's Ethernet MAC address.
31	HW Addr 4	The third least significant byte in the adapter's Ethernet MAC address.
32	HW Addr 5	The second least significant byte in the adapter's Ethernet MAC address.
33	HW Addr 6	The least significant byte in the adapter's Ethernet MAC address.
34	IP Addr Act 1	The most significant byte in the adapter's current IP address, or 0 if the adapter does not currently have an IP address.
35	IP Addr Act 2	The second most significant byte in the adapter's current IP address, or 0 if the adapter does not currently have an IP address.
36	IP Addr Act 3	The second least significant byte in the adapter's current IP address, or 0 if the adapter does not currently have an IP address.
37	IP Addr Act 4	The least significant byte in the adapter's current IP address, or 0 if the adapter does not currently have an IP address.
38	Subnet Act 1	The most significant byte in the adapter's current subnet mask, or 0 if the adapter does not currently have a subnet mask.
39	Subnet Act 2	The second most significant byte in the adapter's current subnet mask, or 0 if the adapter does not currently have a subnet mask.
40	Subnet Act 3	The second least significant byte in the adapter's current subnet mask, or 0 if the adapter does not currently have a subnet mask.
41	Subnet Act 4	The least significant byte in the adapter's current subnet mask, or 0 if the adapter does not currently have a subnet mask.
42	Gateway Act 1	The most significant byte in the adapter's current gateway address, or 0 if the adapter does not currently have a gateway address.
43	Gateway Act 2	The second most significant byte in the adapter's current gateway address, or 0 if the adapter does not currently have a gateway address.
44	Gateway Act 3	The second least significant byte in the adapter's current gateway address, or 0 if the adapter does not currently have a gateway address.
45	Gateway Act 4	The least significant byte in the adapter's current gateway address, or 0 if the adapter does not currently have a gateway address.
46	EN Rx Overruns	A count of the number of receive buffer overruns reported by the Ethernet MAC.
47	EN Packets Rcvd	A count of the number of receive packets reported by the Ethernet MAC.
48	EN Rx Errors	A count of the number of receive errors reported by the Ethernet MAC.
49	EN Packets Sent	A count of the number of transmitted packets reported by the Ethernet MAC.
50	EN Tx Errors	A count of the number of transmit errors reported by the Ethernet MAC.

Adapter Diagnostic Items in Multi-Drive Mode

The following diagnostic items can be accessed using DriveExplorer (version 3.01 or higher).

No.	Name	Description
1	Reserved	
2	Drv 0 Logic Cmd	Logic Command being transmitted to drive 0 by the adapter.
3	Drv 0 Reference	Reference being transmitted to drive 0 by the adapter.
4	Reserved	
5	Drv 0 Logic Sts	Logic Status being received from drive 0 by the adapter.
6	Drv 0 Feedback	Feedback being received from drive 0 by the adapter.
7	Drv 1 Logic Cmd	Logic Command being transmitted to drive 1 by the adapter.
8	Drv 1 Reference	Reference being transmitted to drive 1 by the adapter.
9	Drv 1 Logic Sts	Logic Status being received from drive 1 by the adapter.
10	Drv 1 Feedback	Feedback being received from drive 1 by the adapter.
11	Drv 2 Logic Cmd	Logic Command being transmitted to drive 2 by the adapter.
12	Drv 2 Reference	Reference being transmitted to drive 2 by the adapter.
13	Drv 2 Logic Sts	Logic Status being received from drive 2 by the adapter.
14	Drv 2 Feedback	Feedback being received from drive 2 by the adapter.
15	Drv 3 Logic Cmd	Logic Command being transmitted to drive 3 by the adapter.
16	Drv 3 Reference	Reference being transmitted to drive 3 by the adapter.
17	Drv 3 Logic Sts	Logic Status being received from drive 3 by the adapter.
18	Drv 3 Feedback	Feedback being received from drive 3 by the adapter.
19	Drv 4 Logic Cmd	Logic Command being transmitted to drive 4 by the adapter.
20	Drv 4 Reference	Reference being transmitted to drive 4 by the adapter.
21	Drv 4 Logic Sts	Logic Status being received from drive 4 by the adapter.
22	Drv 4 Feedback	Feedback being received from drive 4 by the adapter.
23	DSI Overrun Errs	The number of DSI receive overrun errors.
24	DSI Framing Errs	The number of DSI receive framing errors.
25	DSI CRC Errs	The number of DSI receive CRC errors.
26	Boot Flash Count	Number of boot firmware flash updates made to the adapter after shipping.
27	App Flash Count	Number of application firmware flash updates made to the adapter after shipping.
28	HW Addr 1	The most significant byte in the adapter's Ethernet MAC address.
29	HW Addr 2	The second most significant byte in the adapter's Ethernet MAC address.
30	HW Addr 3	The third most significant byte in the adapter's Ethernet MAC address.
31	HW Addr 4	The third least significant byte in the adapter's Ethernet MAC address.
32	HW Addr 5	The second least significant byte in the adapter's Ethernet MAC address.
33	HW Addr 6	The least significant byte in the adapter's Ethernet MAC address.
34	IP Addr Act 1	The most significant byte in the adapter's current IP address, or 0 if the adapter does not currently have an IP address.
35	IP Addr Act 2	The second most significant byte in the adapter's current IP address, or 0 if the adapter does not currently have an IP address.
36	IP Addr Act 3	The second least significant byte in the adapter's current IP address, or 0 if the adapter does not currently have an IP address.

No.	Name	Description
37	IP Addr Act 4	The least significant byte in the adapter's current IP address, or 0 if the adapter does not currently have an IP address.
38	Subnet Act 1	The most significant byte in the adapter's current subnet mask, or 0 if the adapter does not currently have a subnet mask.
39	Subnet Act 2	The second most significant byte in the adapter's current subnet mask, or 0 if the adapter does not currently have a subnet mask.
40	Subnet Act 3	The second least significant byte in the adapter's current subnet mask, or 0 if the adapter does not currently have a subnet mask.
41	Subnet Act 4	The least significant byte in the adapter's current subnet mask, or 0 if the adapter does not currently have a subnet mask.
42	Gateway Act 1	The most significant byte in the adapter's current gateway address, or 0 if the adapter does not currently have a gateway address.
43	Gateway Act 2	The second most significant byte in the adapter's current gateway address, or 0 if the adapter does not currently have a gateway address.
44	Gateway Act 3	The second least significant byte in the adapter's current gateway address, or 0 if the adapter does not currently have a gateway address.
45	Gateway Act 4	The least significant byte in the adapter's current gateway address, or 0 if the adapter does not currently have a gateway address.
46	EN Rx Overruns	A count of the number of receive buffer overruns reported by the Ethernet MAC.
47	EN Packets Rcvd	A count of the number of receive packets reported by the Ethernet MAC.
48	EN Rx Errors	A count of the number of receive errors reported by the Ethernet MAC.
49	EN Packets Sent	A count of the number of transmitted packets reported by the Ethernet MAC.
50	EN Tx Errors	A count of the number of transmit errors reported by the Ethernet MAC.

Viewing and Clearing Events

The adapter maintains an event queue that reports the history of its actions. You can view the event queue using DriveExplorer (3.01) software.

Figure 8.2 DriveExplorer Event View/Clear Screen

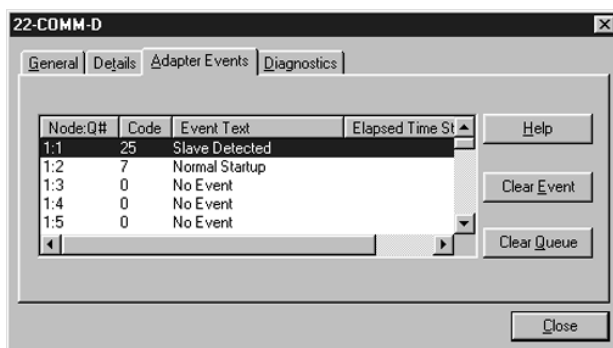

Events

Many events in the Event queue occur under normal operation. If you encounter unexpected communications problems, the events may help you or Allen-Bradley personnel troubleshoot the problem. The following events may appear in the event queue:

Code	Event	Description
Adapter Events		
0	No Event	Text displayed in an empty event queue entry.
1	Normal Startup	Power is applied to the adapter.
2	Manual Reset	The adapter was reset from the "Reset Module" parameter.
3	Watchdog T/O Flt	The software watchdog detected a failure and reset the adapter.
4	App Updated	The application firmware has been flash updated.
5	Boot Updated	The boot firmware has been flash updated.
6	EEPROM Sum Flt	The EEPROM checksum/CRC is incorrect. The functionality of the adapter will be limited. Default parameter values must be loaded to clear the condition.
7 – 9	Reserved	
DSI Events		
10	Slave Detected	The adapter detected that the slave has been connected.
11	Slave Removed	The adapter detected that the slave has been disconnected.
12	Slave Logon	The adapter has established communications with the slave.
13	Slave Timeout	The adapter has lost communications with the slave.
14	Slave Brand Flt	The slave brand is different than the adapter.
15	Host 0 Logon	The adapter has established communications with host 0.
16	Host 1 Logon	The adapter has established communications with host 1.
17	Host 2 Logon	The adapter has established communications with host 2.
18	Host 3 Logon	The adapter has established communications with host 3.
19	Host 4 Logon	The adapter has established communications with host 4.
20	Host 0 Timeout	The adapter has lost communications with host 0.
21	Host 1 Timeout	The adapter has lost communications with host 1.
22	Host 2 Timeout	The adapter has lost communications with host 2.
23	Host 3 Timeout	The adapter has lost communications with host 3.
24	Host 4 Timeout	The adapter has lost communications with host 4.
25	Host 0 Brand Flt	The host 0 brand is different than the adapter.
26	Host 1 Brand Flt	The host 1 brand is different than the adapter.
27	Host 2 Brand Flt	The host 2 brand is different than the adapter.
28	Host 3 Brand Flt	The host 3 brand is different than the adapter.
29	Host 4 Brand Flt	The host 4 brand is different than the adapter.
30–39	Reserved	
Network Events		
40	EN Link Up	The network link is established.
41	EN Link Down	The network link is lost.
42	Dup IP Addr	The adapter detected that another device is using its network address. In this case, the adapter will not participate in any network activity.

Code	Event	Description
43	EN Open	An I/O connection from the network to the adapter was opened.
44	EN Close	An I/O connection from the network to the adapter was closed.
45	EN Timeout	An I/O connection from the network to the adapter has timed out.
46	EN Comm Flt	The adapter has performed the "Comm Flt" action specified by the user.
47	EN Idle Flt	The adapter has performed the "Idle Flt" action specified by the user.
48	PCCC IO Open	The adapter has begun receiving PCCC Control messages (the PCCC Control Timeout was previously set to a non-zero value).
49	PCCC IO Close	The device sending PCCC Control messages to the adapter has set the PCCC Control Timeout to a value of zero.
50	PCCC IO Time Flt	The adapter has not received a PCCC Control message for longer than the PCCC Control Timeout.
51	EN Sent Reset	The adapter received a reset from the network.
52	Msg Ctrl Open	The adapter has begun receiving Client-Server Control messages (the Client-Server Control Timeout was previously set to a non-zero value).
53	Msg Ctrl Close	The device sending Client-Server Control messages to the adapter has set the Client-Server Control Timeout to a value of zero.
54	Msg Ctrl Timeout	The adapter has not received a Client-Server Control message for longer than the established timeout period.
55-59	Reserved	
Adapter-Specific Events		
60	BOOTP Response	The adapter received a response to its BOOTP request.
61	E-mail Failed	The adapter attempted to send an e-mail notice, but could not deliver the message to the mail server.

Viewing the Adapter's Web Pages

Chapter 9 provides instructions on how to monitor the adapter and connected PowerFlex drive using the adapter's web interface.

Topic	Page	Topic	Page
Accessing the Adapter's Web Home Page	9-1	Configure E-mail Notification Web Page	9-8
Process Display Pop-up Windows	9-6	Configure Process Display Web Page	9-10
TCP/IP Configuration Web Page	9-7	DSI Device Information Pages	9-11

Future enhancements may result in adapter web pages that look different than the examples shown in this chapter.

Accessing the Adapter's Web Home Page

After configuring the adapter, you can view its web pages. These pages present information about the adapter, the drive to which it is connected, and other DSI devices connected to the drive such as a HIM or other daisy-chained drives (when adapter is operated in Multi-Drive mode).



TIP: By default the adapter web pages are disabled. To enable the web pages, set the Web Pages Switch (SW2 in [Figure 2.1](#)) to its “Enable Web” position and then reset the adapter.

The adapter can be configured to automatically send e-mail messages to desired addresses when selected drive faults occur and/or are cleared, and/or when the adapter takes a communication or idle fault action. For more details, see the [Configure E-mail Notification Web Page](#) section in this chapter.

Bits 0 and 1 of **Parameter 30 - [Web Features]** can be used to respectively protect the configured settings for e-mail notification and the Process Display web page. The process display settings determine the parameters whose values you want shown in the “Process status” field on the Home page and the Process Display pop-up window for the host. (When the adapter is operated in Multi-Drive mode, the Home Page does not show a “Process status” field for a host.) For details to protect settings, refer to [Chapter 3, Setting Web Features Access](#).

To view the web pages of the adapter

1. On a computer with access to the EtherNet/IP network on which the adapter is installed, launch a web browser such as Microsoft[™] Internet Explorer (version 5.0 or greater) or Netscape[®] Navigator[®] (version 4.6 or greater).

The computer can access the adapter web pages if it is connected to the same network as the adapter, or if it is connected to a network with access to the adapter's network via a gateway device (for example, a router).

2. In the Address box (Explorer) or Location box (Navigator), type the IP address of the adapter, and then press ENTER. The web Home Page for the adapter appears.

Important: Clicking the browser's Refresh button always re-displays the Home Page even while viewing another adapter web page.

Figure 9.1 Adapter Web Home Page Example (Single Mode)

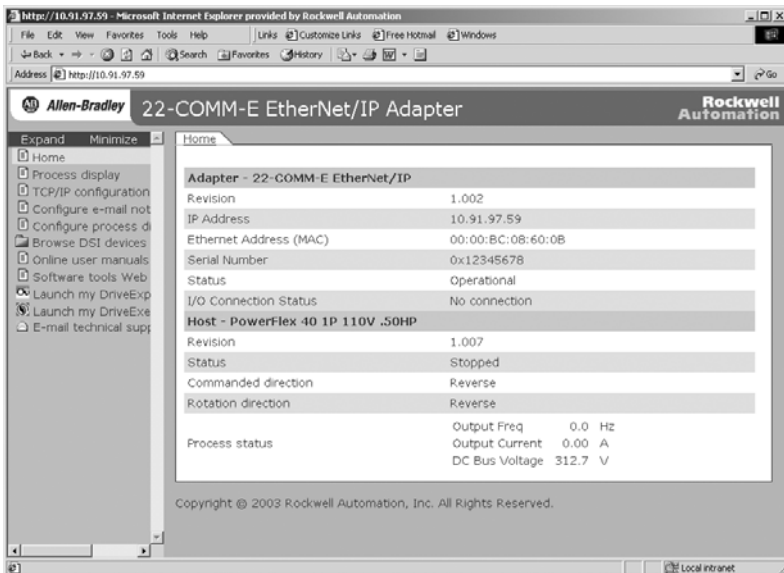
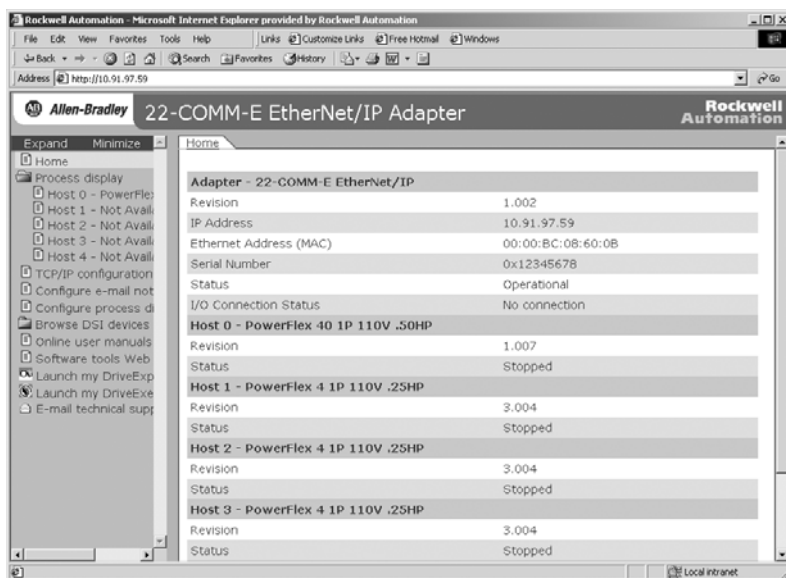

Figure 9.2 Adapter Web Home Page Example (Multi-Drive mode)



Title Bar on Adapter Web Pages

The title bar appears on all adapter web pages, including its Home Page. It consists of three elements:

Item	Description
Allen-Bradley logo (at far left)	This logo is also a link. Click it to view the ab.com web Home Page.
Adapter Title (middle)	Shows the adapter type and title.
Rockwell Automation logo (at far right)	This logo is also a link. Click it to view the Rockwell Automation web Home Page.

Navigation Menu on Adapter Web Pages

The navigation menu appears on the left side of all adapter web pages, including its Home Page. The navigation menu consists of links and link folders which can be expanded or minimized. There are some slight differences in the navigation menu when the adapter is operated in Single mode versus Multi-Drive mode. These differences are highlighted

in the following table, which shows all of the navigation menu's links and link folders:

Link/Folder	Description
Home link	Click this link to view the adapter's Home Page (Figure 9.1 or Figure 9.2).
Process Display link (only Single mode)	Click this link to view the Host's Process Display pop-up window (Figure 9.3) showing dynamic process information (updates every 3 seconds).
Process Display folder (only Multi-Drive mode)	Click this folder to expand and view the links for all connected hosts (Host 0 – X). Then click a respective host's link to view its Process Display pop-up window (Figure 9.3) showing dynamic process information (updates every 3 seconds).
TCP/IP configuration link	Click this link to view the adapter's TCP/IP Configuration web page showing information about the TCP/IP configuration, such as the adapter's IP address and the number of packets being sent. Figure 9.4 shows an example TCP/IP Configuration web page.
Configure e-mail notification link	Click this link to view the adapter's Configure E-mail Notification web page (Figure 9.5) for configuring the adapter to send automatic e-mail messages. See Figure 9.6 for an example e-mail message.
Configure process display link	Click this link to view the adapter's Configure Process Display web page (Figure 9.7) for configuring the parameters whose values you want shown in the "Process status" field on the Home Page (static values) and the Process Display pop-up window for the host (dynamic values).
Browse DSI devices folder	Click this folder to expand and view the Port folders for all present DSI devices, including the drive, adapter, and other DSI devices connected to the drive such as a HIM or other daisy-chained drives (when the adapter is in Multi-Drive mode).
Port 0 – X folders (X = total connected hosts)	Click a respective Port folder to expand and view its device's "Module information" link, "Module diagnostics" link, and "Fault queue" link, which take you to related information pages. See Figure 9.8 , Figure 9.9 , and Figure 9.10 for examples of these pages.
Online user manuals link	Click this link to view Allen-Bradley's web page with documentation for drives and other devices.
Software tools Web site link	Click this link to view Allen-Bradley's web page with information about software tools such as DriveExplorer and DriveExecutive.
Launch my DriveExplorer software link	Click this link to launch the DriveExplorer software already installed on your PC.
Launch my DriveExecutive software link	Click this link to launch the DriveExecutive software already installed on your PC.
E-mail technical support link	Click this link to view a new e-mail message window to send a message to Allen-Bradley's Technical Support Team.

Information on Adapter Home Page

The adapter Home Page displays the following information for the adapter and host:

Item	Description
Adapter Information	<ul style="list-style-type: none">• Revision• IP Address• Ethernet Address (MAC)• Serial Number• Status• I/O connection status
Host "X" Information	Information for each connected host includes: <u>Adapter In Single Mode</u> <ul style="list-style-type: none">• Revision• Status• Commanded direction• Rotation direction• Process status <u>Adapter In Multi-Drive Mode</u> <ul style="list-style-type: none">• Revision• Status

Process Display Pop-up Windows

The Process Display pop-up window dynamically shows a host's information. To view this window, click the "Process Display" link in the navigation menu.



TIP: To view Process Display pop-up windows when the adapter is operated in Multi-Drive mode, expand the "Process Display" folder and click the respective Host "X" link.

Figure 9.3 Example of Process Display Pop-up Window for Host 0

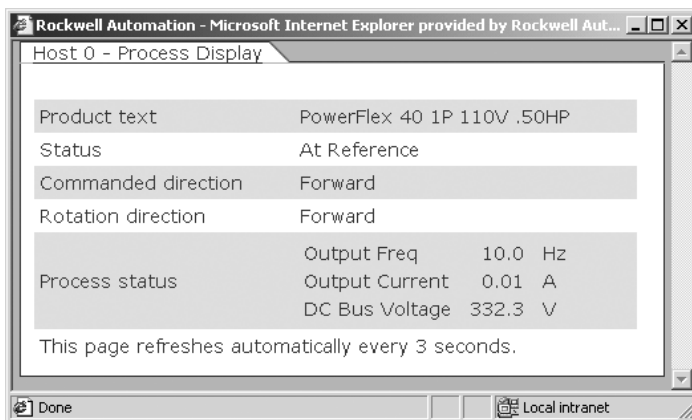

Information	Description
Product text	Description of host.
Status	Status of host.
Commanded direction	Commanded direction of host.
Rotation direction	Rotation direction of host.
Process status	Line 1 – desired parameter of host and its dynamic value. ⁽¹⁾ Line 2 – desired parameter of host and its dynamic value. ⁽¹⁾ Line 3 – desired parameter of host and its dynamic value. ⁽¹⁾

⁽¹⁾ The parameter whose value is shown on this line can be set by using the Configure Process Display web page. For details, see the [Configure Process Display Web Page](#) section in this chapter.

TCP/IP Configuration Web Page

The TCP/IP Configuration web page provides details about the adapter's EtherNet/IP settings and network activities.

Figure 9.4 Example of TCP/IP Configuration Web Page

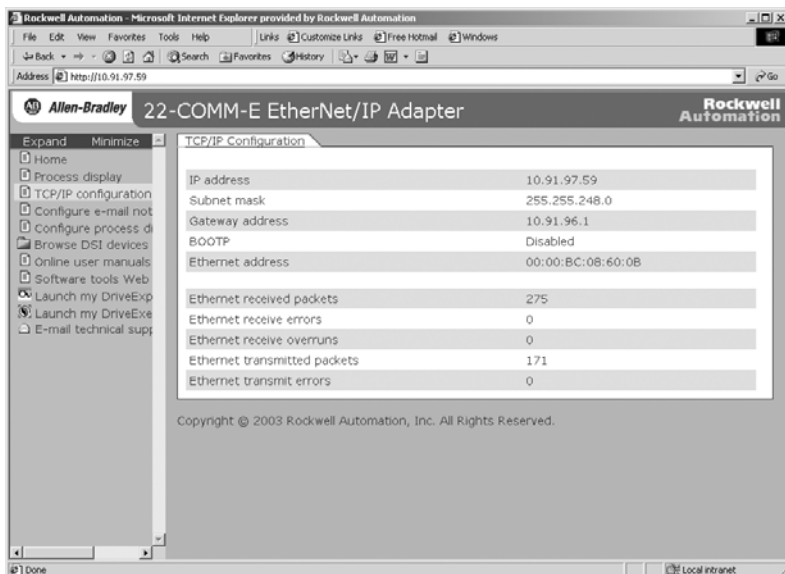

Information	Description
IP Address	IP address of the adapter.
Subnet Mask	Subnet mask for the adapter's network.
Gateway Address	Address for the gateway device on the adapter's network.
BOOTP	Whether BOOTP is being used to configure the adapter's network information.
Ethernet Address	Hardware address for the adapter.
Ethernet received packets	Number of packets that the adapter has received.
Ethernet receive errors	Number of receive errors reported by the hardware.
Ethernet receive overruns	Number of receive buffer overruns reported by the hardware.
Ethernet transmitted packets	Number of packets that the adapter has sent.
Ethernet transmit errors	Number of transmit errors reported by the hardware.

Configure E-mail Notification Web Page

The Configure E-mail Notification web page contains selections and data fields for configuring the adapter to automatically send e-mail messages to desired addresses when selected types of events occur. By default, this configuration is not protected. After configuration, the settings can be protected by setting the **Parameter 30 - [Web Features] E-mail Cfg Bit 0** value to "0" (Disabled). To change a protected configuration, it must first be unprotected by setting the E-mail Cfg Bit 0 value back to "1" (Enabled). For more information, see [Chapter 3, Setting Web Features Access](#).

Figure 9.5 Example of Configure E-mail Notification Web Page

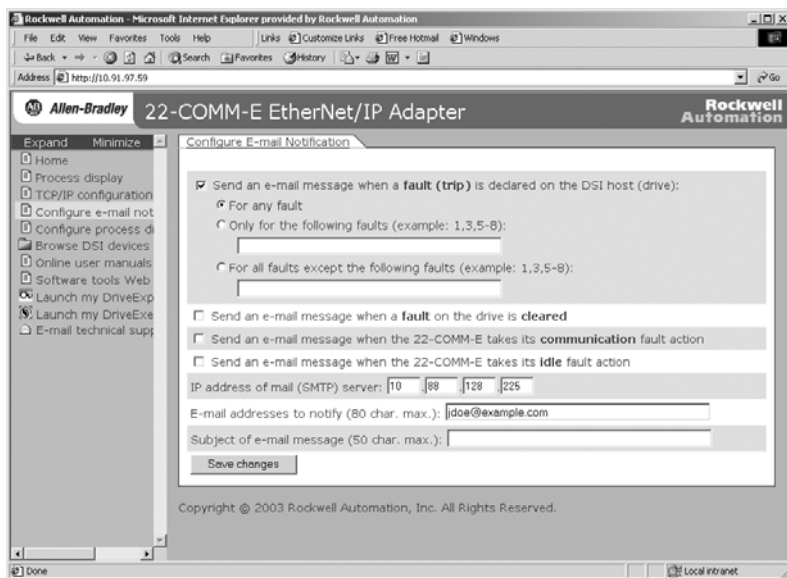

To configure e-mail notification

1. Click the desired Host Faults check boxes you want to occur that will send e-mail notification:
 - If you only want e-mail notification when specific faults occur, click this radio button and type the fault numbers in the box.
 - If you only want e-mail notification when all faults except specific faults occur, click this radio button and type the fault numbers in the box.

- Click the desired Adapter Faults check boxes you want to occur that will send e-mail notification.
- Type the following information in their respective boxes:

Information	Description
"IP address of ..."	Type in the address of the mail server that will be used to deliver the e-mail messages.
"E-mail addresses to notify ..."	Type in addresses to where you want e-mail messages to be sent. Multiple addresses can be used, but they must be separated by commas (comma delimited).
"Subject of e-mail message ..."	Type in the desired subject text for the e-mail message.

- Click **Save changes**.

Important: It is recommended that **Parameter 30 - [Web Features] E-mail Cfg Bit 0** value be set to "0" (Disabled) after E-mail Notification has been configured. Otherwise the configuration can be changed anytime the web page is accessed with a browser.

An example of an e-mail message automatically sent by the adapter in response to selected events is shown below.

Figure 9.6 Example of E-mail Message Sent by Adapter

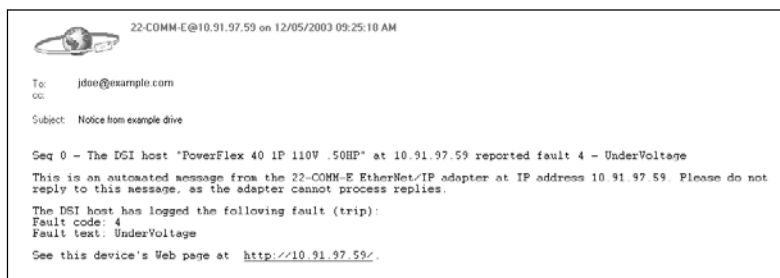

TIP: To stop e-mail messages, do one of the following:

- Delete all e-mail addresses from the Configure E-mail Notification web page.
- Uncheck all of the "Send an e-mail message when ..." boxes.

Disabling the adapter web pages by setting the Web Pages Switch (SW2 in [Figure 2.1](#)) to the "Disable Web" position will NOT stop the adapter from sending e-mail messages.

Configure Process Display Web Page

The Configure Process Display web page enables you to set a host's parameters whose values you want shown in the "Process status" fields on the Home Page and the Process Display pop-up window. (When the adapter is operated in Multi-Drive mode, the Home Page does not show a "Process status" field for a host.) By default, this configuration is not protected. After configuration, the settings can be protected by setting the **Parameter 30 - [Web Features] Proc Dsp Cfg Bit 1** value to "0" (Disabled). To change a protected configuration, it must first be unprotected by setting the Proc Dsp Cfg Bit 1 value back to "1" (Enabled). For more information, see [Chapter 3, Setting Web Features Access](#).

Figure 9.7 Example of Configure Process Display Web Page (Single Mode)

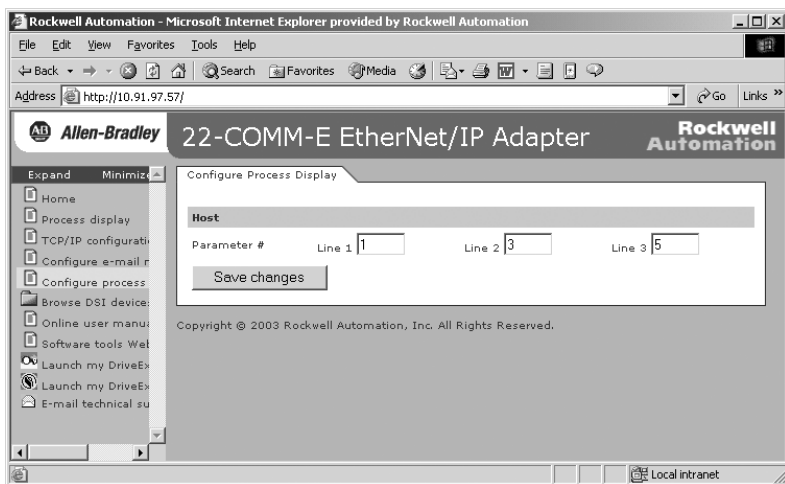

1. To set a host's parameters whose values you want shown on Lines 1, 2, and 3 of the "Process status" fields in both the Home Page (only Single mode) and Process Display pop-up window ([Figure 9.3](#)), type the corresponding parameter number in each box.

Information	Description
Line 1 – parameter #	Number of the parameter whose value you want on Line 1.
Line 2 – parameter #	Number of the parameter whose value you want on Line 2.
Line 3 – parameter #	Number of the parameter whose value you want on Line 3.

2. Click **Save changes**.

Important: It is recommended that **Parameter 30 - [Web Features] Proc Dsp Cfg Bit 1** value be set to “0” (Disabled) after configuration. Otherwise the configuration can be changed anytime the web page is accessed with a browser.

DSI Device Information Pages

DSI device information pages show a device's module information, diagnostic information, and fault queue. [Figure 9.8](#) shows a module information example page for the Port 0 device (host). [Figure 9.9](#) and [Figure 9.10](#) respectively show diagnostic information and fault queue example pages for the Port 5 device (22-COMM-E adapter).

Figure 9.8 Example of Port 0 (PowerFlex 40 Drive) Module Information Page

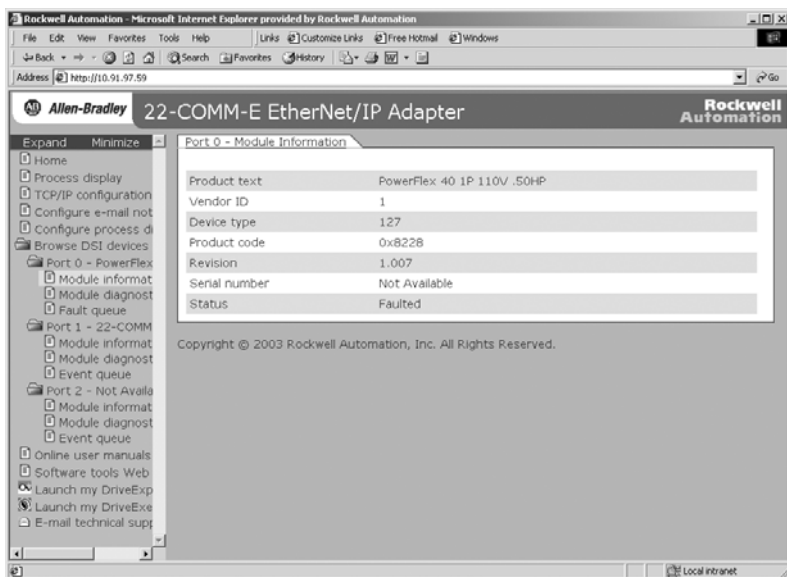

Information	Description
Product text	Text identifying the device
Vendor ID	1 = Allen-Bradley
Device type	127
Product code	Code for the product name and its rating
Revision	Firmware revision used by the device
Serial number	Serial number of the device
Status	Operating status of the device (for example, faulted)

Figure 9.9 Example of Port 5 (22-COMM-E Adapter) Diagnostic Information Page

Rockwell Automation - Microsoft Internet Explorer provided by Rockwell Automation

File Edit View Favorites Tools Help Links Custom Links Free Hotmail Windows

Address http://10.91.97.59

Allen-Bradley 22-COMM-E EtherNet/IP Adapter Rockwell Automation

Expand Minimize Port 5 - Diagnostic Items

Item no.	Description	Value	Units
1	Reserved	0	
2	Drv 0 Logic Cmd	0000 0000 0000 0000	
3	Drv 0 Reference	0	
4	Reserved	0	
5	Drv 0 Logic Sts	0000 0111 1000 0001	
6	Drv 0 Feedback	0	
7	Drv 1 Logic Cmd	0000 0000 0000 0000	
8	Drv 1 Reference	0	
9	Drv 1 Logic Sts	0000 0000 0000 0000	
10	Drv 1 Feedback	0	
11	Drv 2 Logic Cmd	0000 0000 0000 0000	
12	Drv 2 Reference	0	
13	Drv 2 Logic Sts	0000 0000 0000 0000	
14	Drv 2 Feedback	0	
15	Drv 3 Logic Cmd	0000 0000 0000 0000	
16	Drv 3 Reference	0	
17	Drv 3 Logic Sts	0000 0000 0000 0000	
18	Drv 3 Feedback	0	

Local intranet

Figure 9.10 Example of Port 5 (22-COMM-E Adapter) Fault Queue Page

Rockwell Automation - Microsoft Internet Explorer provided by Rockwell Automation

File Edit View Favorites Tools Help Links Custom Links Free Hotmail Windows

Address http://10.91.97.59

Allen-Bradley 22-COMM-E EtherNet/IP Adapter Rockwell Automation

Expand Minimize Port 5 - Event Queue

Entry no.	Event code	Description	Time stamp
1	40	EN Link Up	00:00:01.716
2	24	Host 4 Timeout	00:00:00.768
3	23	Host 3 Timeout	00:00:00.634
4	22	Host 2 Timeout	00:00:00.500
5	21	Host 1 Timeout	00:00:00.366
6	15	Host 0 Logon	00:00:00.247
7	1	Normal Startup	00:00:00.000
8	0	No Event	
9	0	No Event	
10	0	No Event	
11	0	No Event	
12	0	No Event	
13	0	No Event	
14	0	No Event	
15	0	No Event	
16	0	No Event	
17	0	No Event	
18	0	No Event	

Done Local intranet

Specifications

Appendix A presents the specifications for the adapter.

Topic	Page	Topic	Page
Communications	A-1	Environmental	A-2
Electrical	A-1	Regulatory Compliance	A-2
Mechanical	A-1		

Communications

Network	
Protocol	EtherNet/IP
Data Rates	10 Mbps Full Duplex, 10 Mbps Half Duplex, 100 Mbps Full Duplex, or 100 Mbps Half Duplex
Drive	
Protocol	DSI
Data Rates	19.2 kbps

Electrical

Consumption	
Drive	350 mA at 5 VDC supplied through the drive
Network	None

Mechanical

Dimensions	
Height	19 mm (0.75 inches)
Length	86 mm (3.39 inches)
Width	78.5 mm (3.09 inches)
Weight	85g (3 oz.)

Environmental

Temperature	
Operating	-10 to 50°C (14 to 149°F)
Storage	-40 to 85°C (-40 to 185°F)
Relative Humidity	5 to 95% non-condensing
Atmosphere	Important: Adapter must not be installed in an area where the ambient atmosphere contains volatile or corrosive gas, vapors or dust. If the adapter is not going to be installed for a period of time, it must be stored in an area where it will not be exposed to a corrosive atmosphere.

Regulatory Compliance

Certification	Specification
UL	UL508C
cUL	CAN / CSA C22.2 No. 14-M91
CE	EN50178 and EN61800-3
CTick	AS/NZS 2064, Group 1, Class A

NOTE: This is a product of category C2 according to IEC 61800-3. In a domestic environment this product may cause radio interference in which case supplementary mitigation measures may be required.

Adapter Parameters

Appendix B provides information about the EtherNet/IP adapter parameters.

Topic	Page
About Parameter Numbers	B-1
Parameter List	B-1



About Parameter Numbers

The parameters in the adapter are numbered consecutively. However, depending on which configuration tool you use, they may have different numbers.

Configuration Tool	Numbering Scheme
<ul style="list-style-type: none"> • DriveExplorer • DriveExecutive • HIM 	The adapter parameters begin with parameter 1. For example, Parameter 01 - [Mode] is parameter 1 as indicated by this manual.
<ul style="list-style-type: none"> • Explicit Messaging • RSNetWorx for EtherNet/IP 	Refer to Chapter 6, Using Explicit Messaging , and Appendix C, EtherNet/IP Objects , for details.

Parameter List

Parameter			
No.	Name and Description	Details	
01	[Mode] Displays the Single or Multi-Drive operating mode selected with the Operating Mode Switch (SW1) on the adapter.	Default: 0 = Single Drive Values: 0 = Single Drive 1 = Multiple Drive Type: Read Only	
02	[BOOTP] Configures the adapter to use BOOTP so that you can set its IP address, subnet mask, and gateway address with a BOOTP server.	Default: 1 = Enabled Values: 0 = Disabled 1 = Enabled Type: Read/Write Reset Required: Yes	

Parameter			
No.	Name and Description	Details	
15	[EN Rate Cfg] Sets the network data rate at which the adapter communicates.	Default: Values:	0 = Autodetect 0 = Autodetect 1 = 10 Mbps Full 2 = 10 Mbps Half 3 = 100 Mbps Full 4 = 100 Mbps Half
		Type: Reset Required:	Read/Write Yes
16	[EN Rate Act] Displays the network data rate currently being used by the adapter.	Default: Values:	0 = No Link 0 = No Link 1 = 10 Mbps Full 2 = 10 Mbps Half 3 = 100 Mbps Full 4 = 100 Mbps Half
		Type:	Read Only
17	[Reset Module] No action if set to "Ready." Resets the adapter if set to "Reset Module." Restores the adapter to its factory default settings if set to "Set Defaults." This parameter is a command. It will be reset to "0 = Ready" after the command has been performed.	Default: Values	0 = Ready 0 = Ready 1 = Reset Module 2 = Set Defaults
		Type: Reset Required:	Read/Write No
	 <p>ATTENTION: Risk of injury or equipment damage exists. If the adapter is transmitting I/O that controls the drive, the drive may fault when you reset the adapter. Determine how your drive will respond before resetting a connected adapter.</p>		
18	[Comm Fit Action] Sets the action that the adapter and drive will take if the adapter detects that Ethernet communications have been disrupted. This setting is effective only if I/O that controls the drive is transmitted through the adapter.	Default: Values:	0 = Fault 0 = Fault 1 = Stop 2 = Zero Data 3 = Hold Last 4 = Send Fit Cfg
		Type: Reset Required:	Read/Write No
	 <p>ATTENTION: Risk of injury or equipment damage exists. Parameter 18 - [Comm Fit Action] lets you determine the action of the adapter and connected drive if communications are disrupted. By default, this parameter faults the drive. You can set this parameter so that the drive continues to run. Precautions should be taken to ensure that the setting of this parameter does not create a risk of injury or equipment damage. When commissioning the drive, verify that your system responds correctly to various situations (for example, a disconnected drive).</p>		

Parameter		
No.	Name and Description	Details
19	<p>[Idle Flt Action] Sets the action that the adapter and drive will take if the adapter detects that the scanner is idle because the controller was switched to program mode. This setting is effective only if I/O that controls the drive is transmitted through the adapter.</p>	<p>Default: 0 = Fault Values: 0 = Fault 1 = Stop 2 = Zero Data 3 = Hold Last 4 = Send Flt Cfg Type: Read/Write Reset Required: No</p>
<p> ATTENTION: Risk of injury or equipment damage exists. Parameter 19 - [Idle Flt Action] lets you determine the action of the adapter and connected drive if the scanner is idle. By default, this parameter faults the drive. You can set this parameter so that the drive continues to run. Precautions should be taken to ensure that the setting of this parameter does not create a risk of injury or equipment damage. When commissioning the drive, verify that your system responds correctly to various situations (for example, a disconnected drive).</p>		
20	<p>[Flt Cfg Logic] Sets the Logic Command data that is sent to the drive if any of the following is true:</p> <ul style="list-style-type: none"> Parameter 18 - [Comm Flt Action] is set to "Send Flt Cfg" and communications are disrupted. Parameter 19 - [Idle Flt Action] is set to "Send Flt Cfg" and the scanner is put into Program or Test mode. <p>The bit definitions will depend on the product to which the adapter is connected.</p>	<p>Default: 0000 0000 0000 0000 Minimum: 0000 0000 0000 0000 Maximum: 1111 1111 1111 1111 Type: Read/Write Reset Required: No</p>
21	<p>[Flt Cfg Ref] Sets the Reference data that is sent to the drive if any of the following is true:</p> <ul style="list-style-type: none"> Parameter 18 - [Comm Flt Action] is set to "Send Flt Cfg" and communications are disrupted. Parameter 19 - [Idle Flt Action] is set to "Send Flt Cfg" and the scanner is put into Program or Test mode. 	<p>Default: 0 Minimum: 0 Maximum: 65535 Type: Read/Write Reset Required: No</p>
22	<p>[DSI I/O Cfg] Sets the configuration of the Drives that are active in the Multi-Drive mode. Identifies the connections that would be attempted on a reset or power cycle.</p>	<p>Default: 0 Values: 0 = Drive 0 1 = Drives 0-1 2 = Drives 0-2 3 = Drives 0-3 4 = Drives 0-4 Type: Read/Write Reset Required: Yes</p>

Parameter		
No.	Name and Description	Details
23	<p>[DSI I/O Act] Displays the Drives that are active in the Multi-Drive mode.</p> <div style="text-align: center;"> <p>Bit 7 6 5 4 3 2 1 0</p> <p>Default x x x 0 0 0 0 →</p> <p style="margin-left: 100px;">→</p> <p style="margin-left: 100px;">→</p> <p style="margin-left: 100px;">→</p> </div>	<p>Default: xxx0 0000 Bit Values: 0 = Drive Active 1 = Drive Inactive Type: Read Only</p> <hr/> <p>Bit Definitions 0 = Drive 0 Active 1 = Drive 1 Active 2 = Drive 2 Active 3 = Drive 3 Active 4 = Drive 4 Active 5 = Not Used 6 = Not Used 7 = Not Used</p>
24 25 26 27 28	<p>[Drv 0 Addr] [Drv 1 Addr] [Drv 2 Addr] [Drv 3 Addr] [Drv 4 Addr]</p> <p>Sets the corresponding node addresses of the daisy-chained drives when the adapter Operating Mode Switch (SW1) is set for Multi-Drive operation.</p> <p>Important: The settings for these parameters must match the Comm Node Addr parameter settings in the respective drives. Each setting must also be unique (no duplicate node address).</p>	<p>Default: 100 Default: 101 Default: 102 Default: 103 Default: 104 Minimum: 1 Maximum: 247 Type: Read/Write Reset Required: Yes</p>
29	<p>[Web Enable] Displays the setting of the Web Pages Switch (SW2) on the adapter when the adapter was last reset.</p>	<p>Default: 0 = Disabled Values: 0 = Disabled 1 = Enabled Type: Read Only</p>
30	<p>[Web Features] Sets the access to the Web interface and Web-configurable features.</p> <div style="text-align: center;"> <p>Bit 7 6 5 4 3 2 1 0</p> <p>Default x x x x x x 1 1 →</p> <p style="margin-left: 100px;">→</p> <p style="margin-left: 100px;">→</p> </div>	<p>Default: xxxx xx11 Bit Values: 0 = Disabled 1 = Enabled Type: Read/Write Reset Required: No</p> <hr/> <p>Bit Definitions 0 = E-mail Configuration 1 = Process Display Configuration 2-7 = Not used</p>

Notes:

EtherNet/IP Objects

Appendix C provides information about the EtherNet/IP objects that can be accessed using Explicit Messages. For information on the format of Explicit Messages and example ladder logic programs, refer to [Chapter 6, Using Explicit Messaging](#).

Object	Class Code			Object	Class Code		
	Hex.	Dec.	Page		Hex.	Dec.	Page
Identity Object	0x01	1	C-2	DPI Device Object	0x92	146	C-21
Assembly Object	0x04	4	C-4	DPI Parameter Object	0x93	147	C-24
Register Object	0x07	7	C-6	DPI Fault Object	0x97	151	C-28
Parameter Object	0x0F	15	C-9	DPI Diagnostic Object	0x99	153	C-30
Parameter Group Object	0x10	16	C-13	TCP/IP Interface Object	0xF5	245	C-32
PCCC Object	0x67	103	C-15	Ethernet Link Object	0xF6	246	C-34



TIP: Refer to the EtherNet/IP specification for more information about EtherNet/IP objects. Information about the EtherNet/IP specification is available on the ODVA web site (<http://www.odva.org>).

Supported Data Types

Data Type	Description
BYTE	8-bit unsigned integer
WORD	16-bit unsigned integer
DWORD	32-bit unsigned integer
LWORD	64-bit unsigned integer
SINT	8-bit signed integer
USINT	8-bit unsigned integer
INT	16-bit signed integer
UINT	16-bit unsigned integer
DINT	32-bit signed integer
UDINT	32-bit unsigned integer
BOOL	8-bit value -- low bit is true or false
BOOL[n]	Array of n bits
STRING[n]	Array of n characters
SHORT_STRING	1-byte length indicator + that many characters
STRUCT	Structure name only - no size in addition to elements
CONTAINER	32-bit parameter value - sign extended if necessary
TCHAR	8 or 16-bit character
REAL	32-bit floating point

Identity Object

Class Code

Hexadecimal	Decimal
0x01	1

Instances (Single-Drive Mode)

The number of instances is fixed at three and is as shown below:

Instance	Description
0	Class
1	Host drive
2	22-COMM-E
3	22-SCM-232 or 22-HIM-* (when present)

Instances (Multi-Drive Mode)

The number of instances is fixed at one and is as shown below:

Instance	Description
0	Class
1	22-COMM-E

Class Attributes

Attribute ID	Access Rule	Name	Data Type	Description
1	Get	Revision	UINT	1
2	Get	Max Instance	UINT	Total number of instances
6	Get	Max ID Number of Class Attributes	UINT	7
7	Get	Max ID Number of Instance Attributes	UINT	100

Identity Object *(Continued)*

Instance Attributes

Attribute ID	Access Rule	Name	Data Type	Description
1	Get	Vendor ID	UINT	1 = Allen-Bradley
2	Get	Device Type	UINT	127
3	Get	Product Code	UINT	Number identifying product name and rating
4	Get	Revision: Major Minor	STRUCT of: USINT USINT	Value varies Value varies
5	Get	Status	WORD	Bit 0 = Owned Bit 2 = Configured Bit 10 = Recoverable fault Bit 11 = Unrecoverable fault
6	Get	Serial Number	UDINT	Unique 32-bit number
7	Get	Product Name	SHORT_STRING	Product name and rating
9	Get	Configuration Consistency Value	UINT	CRC or checksum representing the configuration of the product
100	Get	NVS Info	STRUCT of: UDINT SHORT_STRING	First NVS instance Sub-assembly name

Services

Service Code	Implemented for:		Service Name
	Class	Instance	
0x01	Yes	Yes	Get_Attributes_All
0x05	No	Yes	Reset
0x0E	Yes	Yes	Get_Attribute_Single

Assembly Object

Class Code

Hexadecimal	Decimal
0x04	4

Instances

Instance	Description
1	All I/O data being read from the DSI drives (read-only)
2	All I/O data written to the DSI drives (read/write)

Class Attributes

Attribute ID	Access Rule	Name	Data Type	Description
1	Get	Revision	UINT	2
2	Get	Max Instance	UINT	2
100	Set	Control Timeout	UINT	Control timeout in seconds

Instance Attributes

Attribute ID	Access Rule	Name	Data Type	Description
1	Get	Number of Members	UINT	1
2	Get	Member List	ARRAY of STRUCT: UINT UINT Packed EPATH	Size of member data Size of member path Member path
3	Conditional ⁽¹⁾	Data	Array of Bits	Data to be transferred
4	Get	Size	UINT	Size of assembly data in bits

⁽¹⁾ For instance 1, access rule for the data attribute is Get. For instance 2, it is Get/Set.

Important: Setting an Assembly object attribute can be done only when the Control Timeout (class attribute 100) has been set to a non-zero value.

Assembly Object *(Continued)***Services**

Service Code	Implemented for:		Service Name
	Class	Instance	
0x0E	Yes	Yes	Get_Attribute_Single
0x10	Yes	Yes	Set_Attribute_Single

Register Object

Class Code

Hexadecimal	Decimal
0x07	7

Instances

Instance	Description	Input/ Output	Size (in bits)
1	Logic Command and Reference for all drives	Out	Varies ⁽¹⁾
2	Logic Status and Feedback for all drives	In	Varies ⁽¹⁾
3	Logic Command and Reference for Drive 0	Out	32
4	Logic Status and Feedback for Drive 0	In	32
5	Logic Command and Reference for Drive 1	Out	32
6	Logic Status and Feedback for Drive 1	In	32
7	Logic Command and Reference for Drive 2	Out	32
8	Logic Status and Feedback for Drive 2	In	32
9	Logic Command and Reference for Drive 3	Out	32
10	Logic Status and Feedback for Drive 3	In	32
11	Logic Command and Reference for Drive 4	Out	32
12	Logic Status and Feedback for Drive 4	In	32
13	Logic Command for all drives — mask-and-match register ⁽²⁾	Out	Varies ⁽¹⁾
14	Logic Command for Drive 0 — mask-and-match register ⁽²⁾	Out	32
15	Logic Command for Drive 1 — mask-and-match register ⁽²⁾	Out	32
16	Logic Command for Drive 2 — mask-and-match register ⁽²⁾	Out	32
17	Logic Command for Drive 3 — mask-and-match register ⁽²⁾	Out	32
18	Logic Command for Drive 4 — mask-and-match register ⁽²⁾	Out	32
19	Logic Command for Drive 0	Out	16
20	Logic Status for Drive 0	In	16
21	Reference for Drive 0	Out	16
22	Feedback for Drive 0	In	16
23	Logic Command for Drive 1	Out	16
24	Logic Status for Drive 1	In	16
25	Reference for Drive 1	Out	16
26	Feedback for Drive 1	In	16

⁽¹⁾ The size for this Register Object instance is 32 bits per drive. For example, if the adapter is operating in Multi-Drive mode, and is configured with Drives 0 through 4, then the size is 160 bits.

⁽²⁾ The structure for this Register Object instance is a Mask word followed by a Command word for each drive. The Logic Command for each drive is set to the value of the second word of the data where there are ones in the first word of the data.

Logic Command = (Logic Command and not Mask word) or (Command word and Mask word)

Register Object *(Continued)*

Instances (Continued)

Instance	Description	Input/ Output	Size (in bits)
27	Logic Command for Drive 2	Out	16
28	Logic Status for Drive 2	In	16
29	Reference for Drive 2	Out	16
30	Feedback for Drive 2	In	16
31	Logic Command for Drive 3	Out	16
32	Logic Status for Drive 3	In	16
33	Reference for Drive 3	Out	16
34	Feedback for Drive 3	In	16
35	Logic Command for Drive 4	Out	16
36	Logic Status for Drive 4	In	16
37	Reference for Drive 4	Out	16
38	Feedback for Drive 4	In	16

Class Attributes

Attribute ID	Access Rule	Name	Data Type	Description
1	Get	Revision	UINT	1
2	Get	Max Instance	UINT	38
3	Get	Number of Instances	UINT	38
100	Set	Control Timeout	UINT	Control timeout in seconds

Register Object *(Continued)*

Instance Attributes

Attribute ID	Access Rule	Name	Data Type	Description
1	Get	Bad Flag	BOOL	If set to 1, then attribute 4 contains invalid, bad or otherwise corrupt data. 0 = good 1 = bad
2	Get	Direction	BOOL	Direction of data transfer 0 = Input (Drive to EtherNet/IP) 1 = Output (EtherNet/IP to Drive)
3	Get	Size	UINT	Size of register data in bits
4	Conditional ⁽¹⁾	Data	ARRAY of BITS	Data to be transferred

⁽¹⁾ The access rule of Set is optional if attribute 2, Direction = 1. If Direction = 0, the access rule is Get.

Important: Setting a Register object attribute can be done only when the Control Timeout (class attribute 100) has been set to a non-zero value.

Service Code	Implemented for:		Service Name
	Class	Instance	
0x0E	Yes	Yes	Get_Attribute_Single
0x10	Yes	Yes	Set_Attribute_Single

Parameter Object

Class Code

Hexadecimal	Decimal
0x0F	15

Instances (Single-Drive Mode)

The number of instances is as shown below:

Instance	Description
0	Class
1	Drive Parameter 1
⌵	⌵
n	Drive Parameter n ⁽¹⁾
n + 1	Adapter Parameter 1
⌵	⌵
n + m	Adapter Parameter m ⁽²⁾

⁽¹⁾ n represents the number of parameters in the drive.

⁽²⁾ m represents the number of parameters in the adapter.

Instances (Multi-Drive Mode)

The number of instances is as shown below:

Instance	Description
0	Class
1	Adapter Parameter 1
⌵	⌵
m	Adapter Parameter m ⁽¹⁾

⁽¹⁾ m represents the number of parameters in the adapter.

In addition, the parameters for the other DSI devices can be accessed using the instance-offset encoding shown in the table below:

Instances (Dec.)	Single-Drive Mode	Multi-Drive Mode
16384 – 17407	Instances 0 – 1023 in the adapter	Instances 0 – 1023 in the adapter
17408 – 18431	Instances 0 – 1023 in the drive	Instances 0 – 1023 in Drive 0
18432 – 19455	Not supported	Instances 0 – 1023 in Drive 1
19456 – 20479	Not supported	Instances 0 – 1023 in Drive 2
20480 – 21503	Not supported	Instances 0 – 1023 in Drive 3
21504 – 22527	Not supported	Instances 0 – 1023 in Drive 4

Parameter Object *(Continued)*

Class Attributes

Attribute ID	Access Rule	Name	Data Type	Description
1	Get	Revision	UINT	1
2	Get	Max Instance	UINT	Number of parameters
8	Get	Parameter Class Descriptor	WORD	0 = False, 1 = True Bit 0 = Supports parameter instances Bit 1 = Supports full attributes Bit 2 = Must do NVS save command Bit 3 = Parameters are stored in NVS
9	Get	Configuration Assembly Instance	UINT	0
10	Get	Native Language	USINT	0 = English 1 = French 2 = Spanish 3 = Italian 4 = German 5 = Japanese 6 = Portuguese 7 = Mandarin Chinese 8 = Russian 9 = Dutch

Parameter Object *(Continued)*

Instance Attributes

Attribute ID	Access Rule	Name	Data Type	Description
1	(1)	Parameter Value	(2)	(3)
2	Get	Link Path Size	USINT	0 = No link specified n = The size of Attribute 3 in bytes
3	Get	Link Path		(4)
4	Get	Descriptor	WORD	0 = False, 1 = True Bit 1 = Supports ENUMs Bit 2 = Supports scaling Bit 3 = Supports scaling links Bit 4 = Read only Bit 5 = Monitor Bit 6 = Extended precision scaling
5	Get	Data Type	USINT	0xC2 = SINT (8-bits) 0xC3 = INT (16-bits) 0xC4 = DINT (32-bits) 0xC6 = USINT (8-bits) 0xC7 = UINT (16-bits) 0xCA = REAL (32-bits) 0xD2 = WORD (16-bits)
6	Get	Data Size	USINT	(3)
7	Get	Parameter Name String	SHORT_STRING	(3)
8	Get	Units String	SHORT_STRING	(3)
9	Get	Help String	SHORT_STRING	Null string
10	Get	Minimum Value	(1)	(3)
11	Get	Maximum Value	(1)	(3)
12	Get	Default Value	(1)	(3)
13	Get	Scaling Multiplier	UINT	(3)
14	Get	Scaling Divisor	UINT	(3)
15	Get	Scaling Base	UINT	(3)
16	Get	Scaling Offset	UINT	(3)
17	Get	Multiplier Link	UINT	(3)
18	Get	Divisor Link	UINT	(3)
19	Get	Base Link	UINT	(3)
20	Get	Offset Link	UINT	(3)
21	Get	Decimal Precision	USINT	(3)

(1) Access rule is defined in bit 4 of instance attribute 4. 0 = Get/Set, 1 = Get.

(2) Specified in descriptor, data type, and data size.

(3) Value varies based on parameter instance.

(4) Refer to the CIP Common specification for a description of the link path.

Parameter Object *(Continued)***Services**

Service Code	Implemented for:		Service Name
	Class	Instance	
0x01	Yes	Yes	Get_Attribute_All
0x05	Yes	No	Reset
0x0E	Yes	Yes	Get_Attribute_Single
0x10	No	Yes	Set_Attribute_Single
0x4B	No	Yes	Get_Enum_String

Parameter Group Object

Class Code

Hexadecimal	Decimal
0x10	16

Instances

The number of instances depends on the number of groups in the device. A group of adapter parameters is appended to the list of groups in the device. The total number of groups can be read in Instance 0, Attribute 2.

Number	Description
0	Class Attributes
1	Drive Group 1 Attributes
⋮	⋮
n	Drive Group n Attributes ⁽¹⁾
n + 1	Adapter Group Attributes

⁽¹⁾ n represents the number of parameter groups in the drive.

Class Attributes

Attribute ID	Access Rule	Name	Data Type	Description
1	Get	Parameter group version	UINT	1
2	Get	Max Instance	UINT	Total number of groups
8	Set	Native Language	USINT	0 = English 1 = French 2 = Spanish (Mexican) 3 = Italian 4 = German 5 = Japanese 6 = Portuguese 7 = Mandarin Chinese 8 = Russian 9 = Dutch

Parameter Group Object *(Continued)*

Instance Attributes

Attribute ID	Access Rule	Name	Data Type	Description
1	Get	Group Name String	SHORT_STRING	Group name
2	Get	Number of Members in Group	UINT	Number of parameters in group.
3	Get	1st Parameter Number in Group	UINT	⁽¹⁾
4	Get	2nd Parameter Number in Group	UINT	⁽¹⁾
n	Get	:	UINT	⁽¹⁾

⁽¹⁾ Value varies based on group instance.

Services

Service Code	Implemented for:		Service Name
	Class	Instance	
0x0E	Yes	Yes	Get_Attribute_Single
0x01	Yes	Yes	Get_Attributes_All

PCCC Object

Class Code

Hexadecimal	Decimal
0x67	103

Instances

Supports Instance 1.

Class Attributes

Not supported.

Instance Attributes

Not supported.

Services

Service Code	Implemented for:		Service Name
	Class	Instance	
0x4B	No	Yes	Execute_PCCC
0x4C	No	Yes	Execute_DH+

Message Structure for Execute_PCCC

Request		
Name	Data Type	Description
Length	USINT	Length of requestor ID
Vendor	UINT	Vendor number of requestor
Serial Number	UDINT	ASA serial number of requestor
Other	Product Specific	Identifier of user, task, etc. on the requestor
CMD	USINT	Command byte

Response		
Name	Data Type	Description
Length	USINT	Length of requestor ID
Vendor	UINT	Vendor number of requestor
Serial Number	UDINT	ASA serial number of requestor
Other	Product Specific	Identifier of user, task, etc. on the requestor
CMD	USINT	Command byte

PCCC Object *(Continued)*

Message Structure for Execute_PCCC (Continued)

Request			Response		
Name	Data Type	Description	Name	Data Type	Description
STS	USINT	0	STS	USINT	Status byte
TNSW	UINT	Transport word	TNSW	UINT	Transport word. Same value as the request.
FNC	USINT	Function code. Not used for all CMD's.	EXT_STS	USINT	Extended status. Not used for all CMD's.
PCCC_params	ARRAY of USINT	CMD/FNC specific parameters	PCCC_results	ARRAY of USINT	CMD/FNC specific result data

Message Structure for Execute_DH+

Request			Response		
Name	Data Type	Description	Name	Data Type	Description
DLink	UINT	Destination Link ID	DLink	UINT	Destination Link ID
DSta	USINT	Destination Station number	DSta	USINT	Destination Station number
DUser	USINT	Destination "User" number	DUser	USINT	Destination "User" number
SLink	UINT	Source Link ID	SLink	UINT	Source Link ID
SSta	USINT	Source Station number	SSta	USINT	Source Station number
SUser	USINT	Source User number	SUser	USINT	Source User number
CMD	USINT	Command byte	CMD	USINT	Command byte
STS	USINT	0	STS	USINT	Status byte
TNSW	UINT	Transport word	TNSW	UINT	Transport word. Same value as the request.
FNC	USINT	Function code; not used for all CMD's	EXT_STS	USINT	Extended Status; not used for all CMD's
PCCC_params	ARRAY of USINT	CMD/FNC specific parameters	PCCC_results	ARRAY of USINT	CMD/FNC specific result data

PCCC Object *(Continued)*

The adapter supports the following PCCC command types:

CMD	FNC	Description
0x06	0x03	Identify host and some status
0x0F	0x67	PLC-5 typed write
0x0F	0x68	PLC-5 typed read
0x0F	0x95	Encapsulate other protocol
0x0F	0xA2	SLC 500 protected typed read with 3 address fields
0x0F	0xAA	SLC 500 protected typed write with 3 address fields
0x0F	0xA1	SLC 500 protected typed read with 2 address fields
0x0F	0xA9	SLC 500 protected typed write with 2 address fields
0x0F	0x00	Word range read
0x0F	0x01	Word range write

See DF1 Protocol and Command Set Manual, Allen-Bradley Publication No. 1770-6.5.16.

N-Files

N-File	Description												
N40	<p>This N-file lets you use Emulated Block Transfer messages to read and write many types of DPI messages. To use Emulated Block Transfer messages, you send a Write message to N40:0 – N40:63, wait until the adapter responds with a reply message, and then read the response data in N40:0 – N40:63 with a Read message.</p> <p>For details about Block Transfer messages and the data required for each byte in the N-File, refer to the <i>Remote I/O Adapter User Manual</i>, Publication 20COMM-UM004....</p> <p>Bits 15 to 8 are the Most Significant Byte. Bits 7 to 0 are the Least Significant Byte.</p> <table border="1" style="width: 100%; border-collapse: collapse;"> <thead> <tr> <th colspan="2" style="text-align: left;"><i>Write</i></th> <th colspan="2" style="text-align: left;"><i>Read</i></th> </tr> </thead> <tbody> <tr> <td style="text-align: right;">Bits</td> <td style="text-align: center;">15</td> <td style="text-align: center;">0</td> <td style="text-align: center;">15</td> <td style="text-align: center;">0</td> </tr> </tbody> </table>				<i>Write</i>		<i>Read</i>		Bits	15	0	15	0
<i>Write</i>		<i>Read</i>											
Bits	15	0	15	0									
N40:0	0x00	Length (in Bytes)	0x00	Length (in Bytes)									
N40:1	DPI Port ⁽¹⁾	0x81	Status Size	Status Type									
N40:2	0x00	CIP Service	Data										
N40:3	CIP Class		(length varies based on message)										
N40:4	CIP Instance												
N40:5	CIP Attribute												
N40:6	Data												
:	(length varies based on message)												
N40:63													

⁽¹⁾ Use the following DPI Port Assignment table to determine the value for the DPI port.

PCCC Object *(Continued)*

N-Files *(Continued)*

DPI Port Assignments

DPI Port No.	Single-Drive Mode	Multi-Drive Mode
0	The drive	Drive 0
1	The adapter	Drive 1
2	The slave	Drive 2
3	Not supported	Drive 3
4	Not supported	Drive 4
5	Not supported	The adapter

N-File	Description								
	For Single-Drive Mode Only								
N41	<p>This N-file lets you read and write control I/O messages. You can write control I/O messages only when all of the following conditions are true:</p> <ul style="list-style-type: none"> • The adapter is not receiving I/O from a scanner. For example, there is no scanner on the network, the scanner is in idle (program) mode, the scanner is faulted, or the adapter is not mapped to the scanner. • The value of N42:3 is set to a non-zero value. 								
	<table border="1" style="width: 100%;"> <thead> <tr> <th style="text-align: left;"><i>Write</i></th> <th style="text-align: left;"><i>Read</i></th> </tr> </thead> <tbody> <tr> <td>N41:0 Logic Command Word</td> <td>Logic Status Word</td> </tr> <tr> <td>N41:1 Unused</td> <td>Unused</td> </tr> <tr> <td>N41:2 Reference</td> <td>Feedback</td> </tr> </tbody> </table>	<i>Write</i>	<i>Read</i>	N41:0 Logic Command Word	Logic Status Word	N41:1 Unused	Unused	N41:2 Reference	Feedback
<i>Write</i>	<i>Read</i>								
N41:0 Logic Command Word	Logic Status Word								
N41:1 Unused	Unused								
N41:2 Reference	Feedback								
N42	This N-file lets you read and write some values configuring the port								
N42:3	Time-out (read/write): Time (in seconds) allowed between messages to the N41 or N44 file. If the adapter does not receive a message in the specified time, it performs the fault action configured in its [Comm Flt Action] parameter.								
N42:7	Adapter Port Number (read only): DPI port on the drive to which the adapter is connected.								
N42:8	Peer Adapters (read only): Bit field of devices having DPI Peer capabilities.								

PCCC Object *(Continued)*

N-Files (Continued)

N-File	Description	
N44	For Multi-Drive Mode Only	
	<p>This N-file lets you read and write control I/O messages. You can write control I/O messages only when all of the following conditions are true:</p> <ul style="list-style-type: none"> • The adapter is not receiving I/O from a scanner. For example, there is no scanner on the network, the scanner is in idle (program) mode, the scanner is faulted, or the adapter is not mapped to the scanner. • The value of N42:3 is set to a non-zero value. 	
	<i>Write</i>	<i>Read</i>
N44:0	Drive 0 Logic Command	Drive 0 Logic Status
N44:1	Unused	Unused
N44:2	Drive 0 Reference	Drive 0 Feedback
N44:3	Drive 1 Logic Command	Drive 1 Logic Status
N44:4	Drive 1 Reference	Drive 1 Feedback
N44:5	Drive 2 Logic Command	Drive 2 Logic Status
N44:6	Drive 2 Reference	Drive 2 Feedback
N44:7	Drive 3 Logic Command	Drive 3 Logic Status
N44:8	Drive 3 Reference	Drive 3 Feedback
N44:9	Drive 4 Logic Command	Drive 4 Logic Status
N44:10	Drive 4 Reference	Drive 4 Feedback

PCCC Object *(Continued)*

N-Files *(Continued)*

Important: If your controller or HMI platform supports CIP messaging, use the CIP Parameter object to get and set parameters.

N-File	Description	
N10 – N18	These N-files let you read and write parameter values in the drive and the adapter.	
	<i>Single-Drive Mode</i>	<i>Multi-Drive Mode</i>
N10:0	Number of parameters in the drive	Number of parameters in Drive 0
N10:1 – 999	Drive parameters 1 – 999	Drive 0 parameters 1 - 999
N11:0 – 999	Drive parameters 1000 – 1999	Drive 0 parameters 1000 - 1999
N12:0 – 999	Drive parameters 2000 – 2999	Drive 0 parameters 2000 - 2999
N13:0	Number of parameters in this adapter	Number of parameters in this adapter
N13:1 – 999	Parameters 1 – 999 in this adapter	Parameters 1 – 999 in this adapter
N14:0	Number of parameters in this adapter	Number of parameters in Drive 1
N14:1 – 999	Parameters 1 – 999 in this adapter	Drive 1 parameters 1 – 999
N15:0	Number of parameters in the slave	Number of parameters in Drive 2
N15:1 – 999	Parameters 1 – 999 in the slave	Drive 2 parameters 1 – 999
N16:0	Not supported	Number of parameters in Drive 3
N16:1 – 999	Not supported	Drive 3 parameters 1 – 999
N17:0	Not supported	Number of parameters in Drive 4
N17:1 – 999	Not supported	Drive 4 parameters 1 – 999
N18:0	Not supported	Number of parameters in this adapter
N18:1 – 999	Not supported	Parameters 1 – 999 in this adapter

DPI Device Object

Class Code

Hexadecimal	Decimal
0x92	146

Instances

The number of instances depends on the number of components in the device. The total number of components can be read in Instance 0, Class Attribute 4.

Instances (Dec.)	Single-Drive Mode	Multi-Drive Mode
0 – 16383	Instances 0 – 16383 in the drive	Instances 0 – 16383 in Drive 0
16384 – 17407	Instances 0 – 1023 in the adapter	Instances 0 – 1023 in the adapter
17408 – 18431	Instances 0 – 1023 in the adapter	Instances 0 – 1023 in Drive 1
18432 – 19455	Instances 0 – 1023 in the slave	Instances 0 – 1023 in Drive 2
19456 – 20479	Not supported	Instances 0 – 1023 in Drive 3
20480 – 21503	Not supported	Instances 0 – 1023 in Drive 4
21504 – 22527	Not supported	Instances 0 – 1023 in the adapter

Class Attributes

Attribute ID	Access Rule	Name	Data Type	Description
0	Get	Family Code	BYTE	Code identifying the device.
1	Get	Family Text	STRING[16]	Text identifying the device.
2	Set	Language Code	BYTE	0 = English 1 = French 2 = Spanish 3 = Italian 4 = German 5 = Japanese 6 = Portuguese 7 = Mandarin Chinese 8 = Russian 9 = Dutch
3	Get	Product Series	BYTE	1 = A 2 = B ...
4	Get	Number of Components	BYTE	Number of components (e.g., main control board, I/O boards) in the device.

DPI Device Object *(Continued)*

Class Attributes *(Continued)*

Attribute ID	Access Rule	Name	Data Type	Description
5	Set	User Definable Text	STRING[16]	Text identifying the device with a user-supplied name
6	Get	Status Text	STRING[12]	Text describing the status of the device.
7	Get	Configuration Code	BYTE	Identification of variations.
8	Get	Configuration Text	STRING[16]	Text identifying a variation of a family device.
9	Get	Brand Code	WORD	0x0001 = Allen-Bradley
11	Get	NVS Checksum	WORD	Checksum of the Non-Volatile Storage in a device.
12	Get	Class Revision	WORD	2 = DPI
13	Get	Character Set Code	BYTE	0 = SCANport HIM 1 = ISO 8859-1 (Latin 1) 2 = ISO 8859-2 (Latin 2) 3 = ISO 8859-3 (Latin 3) 4 = ISO 8859-4 (Latin 4) 5 = ISO 8859-5 (Cyrillic) 6 = ISO 8859-6 (Arabic) 7 = ISO 8859-7 (Greek) 8 = ISO 8859-8 (Hebrew) 9 = ISO 8859-9 (Turkish) 10 = ISO 8859-10 (Nordic) 255 = ISO 10646 (Unicode)
15	Get	Languages Supported	STRUCT of: BYTE BYTE[n]	Number of Languages Language Codes (See Class Attribute 2)
16	Get	Date of Manufacture	STRUCT of: WORD BYTE BYTE	Year Month Day
17	Get	Product Revision	STRUCT of: BYTE BYTE	Major Firmware Release Minor Firmware Release
18	Get	Serial Number	DWORD	Value between 0x00 and 0xFFFFFFFF

DPI Device Object *(Continued)*

Instance Attributes

Attribute ID	Access Rule	Name	Data Type	Description
3	Get	Component Name	STRING[32]	Name of the component
4	Get	Component Firmware Revision	STRUCT of: BYTE BYTE	Major Revision Minor Revision
5	Get	Component Hardware Change Number	BYTE	
8	Get	Component Serial Number	DWORD	Value between 0x00 and 0xFFFFFFFF

Services

Service Code	Implemented for:		Service Name
	Class	Instance	
0x0E	Yes	Yes	Get_Attribute_Single
0x10	Yes	Yes	Set_Attribute_Single

DPI Parameter Object

Class Code

Hexadecimal	Decimal
0x93	147

Instances

The number of instances depends on the number of parameters in the device. The total number of parameters can be read in Instance 0, Attribute 0.

Instances (Dec.)	Single-Drive Mode	Multi-Drive Mode
0 – 16383	Instances 0 – 16383 in the drive	Instances 0 – 16383 in Drive 0
16384 – 17407	Instances 0 – 1023 in the adapter	Instances 0 – 1023 in the adapter
17408 – 18431	Instances 0 – 1023 in the adapter	Instances 0 – 1023 in Drive 1
18432 – 19455	Instances 0 – 1023 in the slave	Instances 0 – 1023 in Drive 2
19456 – 20479	Not supported	Instances 0 – 1023 in Drive 3
20480 – 21503	Not supported	Instances 0 – 1023 in Drive 4
21504 – 22527	Not supported	Instances 0 – 1023 in the adapter

Class Attributes

Attribute ID	Access Rule	Name	Data Type	Description
0	Get	Number of Instances	WORD	Number of parameters in the device
1	Set	Write Protect Password	WORD	0 = Password disabled n = Password
2	Set	NVS Command Write	BYTE	0 = No Operation 1 = Store values in active memory to NVS 2 = Load values in NVS to active memory 3 = Load default values to active memory
3	Get	NVS Parameter Value Checksum	WORD	Checksum of all parameter values in a user set in NVS
4	Get	NVS Link Value Checksum	WORD	Checksum of parameter links in a user set in NVS
5	Get	First Accessible Parameter	WORD	First parameter available if parameters are protected by passwords. A "0" indicates all parameters are protected.
7	Get	Class Revision	WORD	2 = DPI
8	Get	First Parameter Processing Error	WORD	The first parameter that has been written with a value outside of its range. A "0" indicates no errors.
9	Set	Link Command	BYTE	0 = No Operation 1 = Clear All Parameter Links (This does not clear links to function blocks.)

DPI Parameter Object (Continued)**Instance Attributes**

Attribute ID	Access Rule	Name	Data Type	Description
7	Get	DPI Online Read Full	STRUCT of: BOOL[32] CONTAINER ⁽¹⁾ CONTAINER CONTAINER CONTAINER WORD WORD STRING[4] UINT UINT UINT INT BYTE[3] BYTE STRING[16]	Descriptor (Refer to pages C-26 – C-27) Parameter value Minimum value Maximum value Default value Next parameter Previous parameter Units (e.g., Amp, Hz) Multiplier ⁽²⁾ Divisor ⁽²⁾ Base ⁽²⁾ Offset ⁽²⁾ Link (source of the value) (0 = no link) Always zero (0) Parameter name
8	Get	DPI Descriptor	BOOL[32]	Descriptor (Refer to pages C-26 – C-27)
9	Get/Set	DPI Parameter Value	Various	Parameter value in NVS. ⁽³⁾
10	Get/Set	DPI RAM Parameter Value	Various	Parameter value in temporary memory.
11	Get/Set	DPI Link	BYTE[3]	Link (parameter or function block that is the source of the value) (0 = no link)
12	Get	Help Object Instance	WORD	ID for help text for this parameter
13	Get	DPI Read Basic	STRUCT of: BOOL[32] CONTAINER CONTAINER CONTAINER CONTAINER STRING[16] STRING[4]	Descriptor (Refer to pages C-26 – C-27) Parameter value Minimum value Maximum value Default value Parameter name Units (e.g., Amp, Hz)
14	Get	DPI Parameter Name	STRING[16]	Parameter name
15	Get	DPI Parameter Alias	STRING[16]	Customer supplied parameter name. Only supported by PowerFlex 700S at time of publication.
16	Get	Parameter Processing Error	BYTE	0 = No error 1 = Value is less than the minimum 2 = Value is greater than the maximum

⁽¹⁾ A CONTAINER is a 32-bit block of data that contains the data type used by a parameter value. If signed, the value is sign extended. Padding is used in the CONTAINER to ensure that it is always 32-bits.

⁽²⁾ This value is used in the formulas used to convert the parameter value between display units and internal units. Refer to [Formulas for Converting](#) on page [C-27](#).

⁽³⁾ Do NOT continually write parameter data to NVS. Refer to the attention on page [6-1](#).

DPI Parameter Object *(Continued)*

Descriptor Attributes

Bit	Name	Description
0	Data Type (Bit 1)	Right bit is least significant bit (0). 000 = BYTE used as an array of Boolean 001 = WORD used as an array of Boolean
1	Data Type (Bit 2)	010 = BYTE (8-bit integer) 011 = WORD (16-bit integer)
2	Data Type (Bit 3)	100 = DWORD (32-bit integer) 101 = TCHAR (8-bit (not unicode) or 16-bits (unicode)) 110 = REAL (32-bit floating point value) 111 = Use bits 16, 17, 18
3	Sign Type	0 = unsigned 1 = signed
4	Hidden	0 = visible 1 = hidden
5	Not a Link Sink	0 = Parameter can sink a link 1 = Parameter cannot sink a link
6	Not Recallable	0 = Recallable from NVS 1 = Not Recallable from NVS
7	ENUM	0 = No ENUM text 1 = ENUM text
8	Writable	0 = Read only 1 = Read/write
9	Not Writable When Enabled	0 = Writable when enabled (e.g., drive running) 1 = Not writable when enabled
10	Instance	0 = Parameter value is not a Reference to another parameter 1 = Parameter value refers to another parameter
11	Reserved	Must be zero
12	Decimal Place (Bit 0)	Number of digits to the right of the decimal point. 0000 = 0 1111 = 15
13	Decimal Place (Bit 1)	
14	Decimal Place (Bit 2)	
15	Decimal Place (Bit 3)	
16	Extended Data Type (Bit 1)	Right bit is least significant bit (16). 000 = Reserved
17	Extended Data Type (Bit 2)	001 = DWORD used as an array of Boolean 010 = Reserved
18	Extended Data Type (Bit 2)	011 = Reserved 100 = Reserved 101 = Reserved 110 = Reserved 111 = Reserved

DPI Parameter Object *(Continued)*

Descriptor Attributes (Continued)

Bit	Name	Description
19	Parameter Exists	Reserved
20	Not Used	Reserved
21	Formula Links	Reserved
22	Access Level (Bit 1)	Reserved
23	Access Level (Bit 2)	Reserved
24	Access Level (Bit 3)	Reserved
25	Writable ENUM	Reserved
26	Not a Link Source	0 = Parameter can be a source for a link 1 = Parameter cannot be a source for a link
27	Enhanced Bit ENUM	Reserved
28	Enhanced ENUM	Reserved
29	Not Used	Reserved
30	Not Used	Reserved
31	Not Used	Reserved

Formulas for Converting

Display Value = ((Internal Value + Offset) x Multiplier x Base) / (Divisor x 10^{Decimal Places})

Internal Value = ((Display Value x Divisor x 10^{Decimal Places}) / (Multiplier x Base)) - Offset

Common Services

Service Code	Implemented for:		Service Name
	Class	Instance	
0x0E	Yes	Yes	Get_Attribute_Single
0x10	Yes	Yes	Set_Attribute_Single

Object Specific Services

Service Code	Service Name
0x32	Get_Attributes_Scattered ⁽¹⁾
0x34	Set_Attributes_Scattered ⁽¹⁾

⁽¹⁾ The instance and attribute are ignored for these services.

The table below lists the parameters for the Get_Attributes_Scattered and Set_Attributes_Scattered object-specific service:

Name	Data Type	Description
Scattered Parameters	STRUCT of	—
Parameter Number	WORD	Parameter to read or write
Parameter Value	WORD	Parameter value to read or write (zero when reading)

Important: The STRUCT may repeat up to 64 times in a single message.

DPI Fault Object

Class Code

Hexadecimal	Decimal
0x97	151

Products such as PowerFlex drives use this object for faults. Adapters use this object for events.

Instances

The number of instances depends on the maximum number of faults or events supported in the queue. The maximum number of faults/events can be read in Instance 0, Attribute 2.

Instances (Dec.)	Single-Drive Mode	Multi-Drive Mode
0 – 16383	Instances 0 – 16383 in the drive	Instances 0 – 16383 in Drive 0
16384 – 17407	Instances 0 – 1023 in the adapter	Instances 0 – 1023 in the adapter
17408 – 18431	Instances 0 – 1023 in the adapter	Instances 0 – 1023 in Drive 1
18432 – 19455	Instances 0 – 1023 in the slave	Instances 0 – 1023 in Drive 2
19456 – 20479	Not supported	Instances 0 – 1023 in Drive 3
20480 – 21503	Not supported	Instances 0 – 1023 in Drive 4
21504 – 22527	Not supported	Instances 0 – 1023 in the adapter

Class Attributes

Attribute ID	Access Rule	Name	Data Type	Description
1	Get	Class Revision	WORD	Revision of object
2	Get	Number of Instances	WORD	Maximum number of faults/events that the device can record in its queue
3	Set	Fault Command Write	BYTE	0 = No Operation 1 = Clear Fault/Event 2 = Clear Fault/Event Queue 3 = Reset Device
4	Get	Fault Trip Instance Read	WORD	Fault that tripped the device. For adapters, this value is always 1 when faulted.
5	Get	Fault Data List	STRUCT of: BYTE BYTE WORD[n]	Reserved
6	Get	Number of Recorded Faults	WORD	Number of faults/events in the queue. A "0" indicates the fault queue is empty.
7	Get	Fault Parameter Reference	WORD	Reserved

DPI Fault Object *(Continued)*

Instance Attributes

Attribute ID	Access Rule	Name	Data Type	Description
0	Get	Full/All Information	STRUCT of: WORD STRUCT of: BYTE BYTE STRING[16] STRUCT of: LWORD BOOL[16] WORD CONTAINER[n]	Fault code Fault source DPI port DPI Device Object Fault text Fault time stamp Timer value (0 = Timer not supported) BOOL[0]: (0 = invalid data, 1 = valid data) BOOL[1]: (0 = elapsed time, 1 = real time) BOOL[2 - 15]: Not used Reserved Reserved
1	Get	Basic Information	STRUCT of: WORD STRUCT of: BYTE BYTE STRUCT of: LWORD BOOL[16]	Fault code Fault source DPI port DPI Device Object Fault time stamp Timer value (0 = Timer not supported) BOOL[0]: (0 = invalid data, 1 = valid data) BOOL[1]: (0 = elapsed time, 1 = real time) BOOL[2 - 15]: Not used

Services

Service Code	Implemented for:		Service Name
	Class	Instance	
0x0E	Yes	Yes	Get_Attribute_Single
0x10	Yes	Yes	Set_Attribute_Single

DPI Diagnostic Object

Class Code

Hexadecimal	Decimal
0x99	153

Instances

The number of instances depends on the maximum number of diagnostic items in the device. The total number of diagnostic items can be read in Instance 0, Attribute 2.

Instances (Dec.)	Single-Drive Mode	Multi-Drive Mode
0 – 16383	Instances 0 – 16383 in the drive	Instances 0 – 16383 in Drive 0
16384 – 17407	Instances 0 – 1023 in the adapter	Instances 0 – 1023 in the adapter
17408 – 18431	Instances 0 – 1023 in the adapter	Instances 0 – 1023 in Drive 1
18432 – 19455	Instances 0 – 1023 in the slave	Instances 0 – 1023 in Drive 2
19456 – 20479	Not supported	Instances 0 – 1023 in Drive 3
20480 – 21503	Not supported	Instances 0 – 1023 in Drive 4
21504 – 22527	Not supported	Instances 0 – 1023 in the adapter

Class Attributes

Attribute ID	Access Rule	Name	Data Type	Description
1	Get	Class Revision	WORD	1
2	Get	Number of Instances	WORD	Number of diagnostic items in the device
3	Get	ENUM Offset	WORD	DPI ENUM object instance offset

DPI Diagnostic Object (Continued)**Instance Attributes**

Attribute ID	Access Rule	Name	Data Type	Description
0	Get	Full/All Info	STRUCT of: BOOL[32] CONTAINER (1) CONTAINER CONTAINER CONTAINER WORD WORD STRING[4] UINT UINT UINT INT DWORD STRING[16]	Descriptor (Refer to pages C-26 – C-27) Value Minimum value Maximum value Default value Pad Word Pad Word Units (e.g., Amp, Hz) Multiplier (2) Divisor (2) Base (2) Offset (2) Link (source of the value) (0 = no link) Always zero (0) Parameter name
1	Get/Set	Value	Various	Diagnostic item value

(1) A CONTAINER is a 32-bit block of data that contains the data type used by a value. If signed, the value is sign extended. Padding is used in the CONTAINER to ensure that it is always 32-bits.

(2) This value is used in the formulas used to convert the value between display units and internal units. Refer to [Formulas for Converting](#) on page [C-27](#).

Services

Service Code	Implemented for:		Service Name
	Class	Instance	
0x0E	Yes	Yes	Get_Attribute_Single
0x10	Yes	Yes	Set_Attribute_Single

TCP/IP Interface Object

Class Code

Hexadecimal	Decimal
0xF5	245

Instances

The adapter supports one instance of the TCP/IP Interface object.

Number	Description
0	Class Attributes
1	Object Attributes

Class Attributes

Attribute ID	Access Rule	Name	Data Type	Description
1	Get	Revision	UINT	The revision of this object

Instance Attributes

Attribute ID	Access Rule	Name	Data Type	Description
1	Get	Status of TCP/IP Network Interface	DWORD	0 = Not configured 1 = Valid configuration 2 to 15 = Reserved
2	Get	Configuration Capability	DWORD	Bit I Value (0 = False, 1 = True) 0 = Supports BOOTP 1 = DNS Client (Able to resolve host names by query to DNS server) 2 = DHCP Client (Able to obtain network configuration through DHCP) 3 = DHCP-DNS Update (Able to send its host name in the DHCP request) 4 = Configuration Settable (Able to set the network configuration via TCP/IP) 5 to 31 = Reserved

TCP/IP Interface Object *(Continued)*

Instance Attributes (Continued)

Attribute ID	Access Rule	Name	Data Type	Description
3	Set	Configuration Control	DWORD	Bit l (Value) 1 – 3 = Startup configuration (0 = Use configuration saved in NVS) (1 = Obtain configuration via BOOTP) (2 = Obtain configuration via DHCP) (3 to 15 = Reserved) 4 = DNS Enabled (Resolves host names by query to DNS server) 5 to 31 = Reserved
4	Get	Physical Link Object	STRUCT of: UJINT Padded EPATH	Path size Path
5	Get	Interface Configuration	STRUCT of UDINT UDINT UDINT UDINT UDINT STRING	Adapter's IP address Adapter's subnet mask Adapter's gateway address Primary name server Secondary name server Default domain name
6	Get	Host Name	STRING	Host name when using DHCP

Services

Service Code	Implemented for:		Service Name
	Class	Instance	
0x0E	Yes	Yes	Get_Attribute_Single
0x10	No	Yes	Set_Attribute_Single

Ethernet Link Object

Class Code

Hexadecimal	Decimal
0xF6	246

Instances

The adapter supports one instance of the TCP/IP Interface object.

Number	Description
0	Class Attributes
1	Object Attributes

Class Attributes

Attribute ID	Access Rule	Name	Data Type	Description
1	Get	Revision	UINT	The revision of this object

Instance Attributes

Attribute ID	Access Rule	Name	Data Type	Description
1	Get	Interface Speed	UDINT	Speed in megabits per second (Mbps)
2	Get	Interface Flags	DWORD	Bit I (Value) 0 = Link status (0 = inactive, 1 = active) 1 = Duplex (0 = half duplex, 1 = full duplex) 2 to 31 = Reserved
3	Get	Physical Address	USINT[6]	MAC address (XX-XX-XX-XX-XX-XX) The first octet (USINT[0]) is on the left.

Ethernet Link Object *(Continued)*

Instance Attributes *(Continued)*

Attribute ID	Access Rule	Name	Data Type	Description
4	Get	Interface Counters	STRUCT of: UDINT UDINT UDINT UDINT UDINT UDINT UDINT UDINT UDINT UDINT UDINT UDINT	Octets received Unicast packets received Non-unicast packets received Inbound packets received but discarded Inbound packets with errors (not discarded) Inbound packets with unknown protocol Octets sent Unicast packets sent Non-unicast packets sent Outbound packets discarded Outbound packets with errors
5	Get	Media Counters	STRUCT of: UDINT UDINT UDINT UDINT UDINT UDINT UDINT UDINT UDINT UDINT UDINT UDINT UDINT	RX = Received, TX = Transmitted RX frames not having integral number of octets long RX frames not passing FCS check TX frames having one collision TX frames having multiple collisions Number of times of SQE test error message TX Frames delayed first attempt by busy medium Collisions detected later than 512 bit-times in trans. TX frames failing due to excessive collisions TX frames failing due to intern MAC sublayer TX error Times of carrier sense condition loss during trans. RX frames exceeding the maximum frame size RX frames failing due to intern MAC sublayer RX error

Services

Service Code	Implemented for:		Service Name
	Class	Instance	
0x0E	Yes	Yes	Get_Attribute_Single
0x4C	No	Yes	Get_and_Clear

Notes:

Logic Command/Status Words

Appendix D provides the definitions of the Logic Command/Logic Status words that are used for some products that can be connected to the EtherNet/IP adapter. If you do not see the Logic Command/Logic Status for the product that you are using, refer to your product's documentation.

PowerFlex 4 and PowerFlex 40 Drives

Logic Command Word

Logic Bits																Command	Description
15	14	13	12	11	10	9	8	7	6	5	4	3	2	1	0		
															x	Stop	0 = Not Stop 1 = Stop
															x	Start ⁽¹⁾	0 = Not Start 1 = Start
														x		Jog	0 = Not Jog 1 = Jog
												x				Clear Faults	0 = Not Clear Faults 1 = Clear Faults
										x	x					Direction	00 = No Command 01 = Forward Command 10 = Reverse Command 11 = No Command
									x							Not used	
								x								Not used	
						x	x									Accel Rate	00 = No Command 01 = Accel Rate 1 Command 10 = Accel Rate 2 Command 11 = Hold Accel Rate
				x	x											Decel Rate	00 = No Command 01 = Decel Rate 1 Command 10 = Decel Rate 2 Command 11 = Hold Decel Rate
x	x	x														Reference Select	000 = No Command 001 = Freq Source = Select 010 = Freq Source = Int. Freq 011 = Freq Source = Comm 100 = Preset Freq 0 101 = Preset Freq 1 110 = Preset Freq 2 111 = Preset Freq 3
x																Not used	

⁽¹⁾ A 0 = Not Stop condition (logic 0) must first be present before a 1 = Start condition will start the drive.

PowerFlex 4 and PowerFlex 40 Drives

Logic Status Word

Logic Bits																Status	Description	
15	14	13	12	11	10	9	8	7	6	5	4	3	2	1	0			
																x	Ready	0 = Not Ready 1 = Ready
																x	Active	0 = Not Active 1 = Active
																x	Command Direction	0 = Reverse 1 = Forward
																x	Actual Direction	0 = Reverse 1 = Forward
																x	Accel	0 = Not Accelerating 1 = Accelerating
																x	Decel	0 = Not Decelerating 1 = Decelerating
																x	Alarm	0 = No Alarm 1 = Alarm
																x	Fault	0 = No Fault 1 = Fault
																x	At Speed	0 = Not At Reference 1 = At Reference
																x	Main Freq	0 = Not Controlled By Comm 1 = Controlled By Comm
																x	Operation Command	0 = Not Controlled By Comm 1 = Controlled By Comm
																x	Parameters	0 = Not Locked 1 = Locked
																x	Digital Input 1 Status	
																x	Digital Input 2 Status	
																x	Digital Input 3 Status ⁽¹⁾	
																x	Digital Input 4 Status ⁽¹⁾	

(1) This status is available for only PowerFlex 40 drives with firmware version 2.xx (or higher).

A Adapter

Devices such as drives, controllers, and computers usually require an adapter to provide a communication interface between them and a network such as EtherNet/IP. An adapter reads data on the network and transmits it to the connected device. It also reads data in the device and transmits it to the network.

The 22-COMM-E EtherNet/IP adapter connects PowerFlex Component Class drives to an EtherNet/IP network. Adapters are sometimes also called “cards,” “embedded communication options,” “gateways,” “modules,” and “peripherals.”

B BOOTP (Bootstrap Protocol)

BOOTP lets the adapter configure itself dynamically at boot time if the network has a BOOTP server. The BOOTP server assigns the adapter a pre-configured IP address, a subnet mask, and a gateway address; therefore, you do not have to configure these using the parameters in the adapter. BOOTP can make it easier to administer an EtherNet/IP network. A free version of Rockwell Software’s BOOTP Server can be accessed at <http://www.ab.com/networks>.

Bridge

A bridge refers to a network device that can route messages from one Ethernet network to another.

A bridge also refers to a communications module in a ControlLogix controller that connects the controller to a network. See also Scanner.

C CIP (Common Industrial Protocol)

CIP is the transport and application layer protocol used for messaging over EtherNet/IP, ControlNet, and DeviceNet networks. The protocol is used for implicit messaging (real time I/O) and explicit messaging (configuration, data collection, and diagnostics).

ControlFLASH

ControlFLASH is an Allen-Bradley software tool that lets users electronically update firmware on printed circuit boards. The tool takes advantage of the growing use of flash memory (electronic erasable chips) across industrial control products.

Controller

A controller, also called programmable logic controller, is a solid-state control system that has a user-programmable memory for storage of

instructions to implement specific functions such as I/O control, logic, timing, counting, report generation, communication, arithmetic, and data file manipulation. A controller consists of a central processor, input/output interface, and memory. See also Scanner.

D Data Rate

The data rate is the speed at which data is transferred on the EtherNet/IP network.

You can set the adapter to a data rate of 10 Mbps Full-Duplex, 10 Mbps Half-Duplex, 100 Mbps Full-Duplex, or 100 Mbps Half-Duplex. If another device on the network sets or auto-negotiates the data rate, you can set the adapter to automatically detect the data rate.

DSI (Drive Serial Interface)

DSI is based on the ModBus RTU serial communication protocol and is used by various Allen-Bradley drives and power products.

DSI Peripheral

A device that provides an interface between DSI and a network or user. Peripheral devices are also referred to as “adapters” and “modules.” The serial converter and PowerFlex 4-Class HIMs (22-HIM-xxx) are examples of DSI peripherals.

DSI Product

A device that uses the DSI communications interface to communicate with one or more peripheral devices. For example, a motor drive such as a PowerFlex 4-Class drive is a DSI product. In this manual, a DSI product is also referred to as “drive” or “host.”

DriveExplorer Software

DriveExplorer software is a tool for monitoring and configuring Allen-Bradley products and adapters. It can be run on computers running Microsoft Windows 95, Windows 98, Windows NT (version 4.0 or higher), Windows 2000, and Windows CE (version 2.0 or higher) operating systems. DriveExplorer (version 3.xx) can be used to configure this adapter and PowerFlex drives. Information about DriveExplorer software and a free lite version can be accessed at <http://www.ab.com/drives/driveexplorer>.

DriveTools SP Software

A software suite designed for Microsoft Windows 95, Windows 98, Windows NT (4.0 or higher), and Windows 2000 operating systems. This software suite provides a family of tools that you can use to program, monitor, control, troubleshoot, and maintain Allen Bradley

products. DriveTools SP (version 3.01) can be used with Allen-Bradley drives. Information about DriveTools SP can be accessed at <http://www.ab.com/drives/drivetools>.

Duplex

Duplex describes the mode of communication. *Full-duplex* communications let a device exchange data in both directions at the same time. *Half-duplex* communications let a device exchange data only in one direction at a time. The duplex used by the adapter depends on the type of duplex that other network devices, such as switches, support.

E EDS (Electronic Data Sheet) Files

EDS files are simple text files that are used by network configuration tools such as RSNetWorx for EtherNet/IP to describe products so that you can easily commission them on a network. EDS files describe a product device type, revision, and configurable parameters. EDS files for many Allen-Bradley products can be found at <http://www.ab.com/networks/eds>.

EtherNet/IP Network

Ethernet/IP (Industrial Protocol) is an open producer-consumer communication network based on the Ethernet standard (IEEE 802.3), TCP/IP, UDP/IP, and CIP. Designed for industrial communications, both I/O and explicit messages can be transmitted over the network. Each device is assigned a unique IP address and transmits data on the network. The number of devices that an EtherNet/IP network can support depends on the class of IP address. For example, a network with a Class C IP address can have 254 nodes.

General information about EtherNet/IP and the EtherNet/IP specification are maintained by the Open DeviceNet Vendor's Association (ODVA). ODVA is online at <http://www.odva.org>.

Explicit Messaging

Explicit Messages are used to transfer data that does not require continuous updates. They are typically used to configure, monitor, and diagnose a device over the network.

F Fault Action

A fault action determines how the adapter and connected drive act when a communications fault (for example, a cable is disconnected) occurs or when the scanner is switched out of run mode. The former uses a communications fault action, and the latter uses an idle fault action.

Fault Configuration

When communications are disrupted (for example, a cable is disconnected), the adapter and PowerFlex drive can respond with a user-defined fault configuration. The user sets the data that is sent to the drive in the fault configuration parameters (**Parameter 20 - [Flt Cfg Logic]** and **Parameter 21 - [Flt Cfg Ref]**). When a fault action parameter is set to use the fault configuration and a fault occurs, the data from these parameters is sent as the Command Logic and/or Reference.

Flash Update

The process of updating firmware in the adapter. The adapter can be flash updated using the X-Modem protocol and a 1203-SSS Smart Self-powered Serial converter (version 3.xx or higher firmware), the Allen-Bradley software tool ControlFLASH, or the built-in flash capability of DriveExplorer (version 4.01 or higher).

G Gateway

A gateway is a device on a network that connects an individual network to a system of networks. When a node needs to communicate with a node on another network, a gateway transfers the data between the two networks. You need to configure the address for the gateway device in the adapter if you want the adapter to communicate with devices that are not on its network.

H Hardware Address

Each Ethernet device has a unique hardware address (sometimes called a MAC address) that is 48 bits. The address appears as six digits separated by colons (for example, xx:xx:xx:xx:xx:xx). Each digit has a value between 0 and 255 (0x00 and 0xFF). This address is assigned in the hardware and cannot be changed. It is required to identify the device if you are using a BOOTP utility.

HIM (Human Interface Module)

A device that can be used to configure and control a PowerFlex 4-Class drive. PowerFlex 4-Class HIMs (22-HIM-xxx) can be used to configure connected peripherals.

Hold Last

When communications are disrupted (for example, a cable is disconnected), the adapter and PowerFlex drive can respond by holding last. Hold last results in the drive receiving the last data received via the Ethernet connection before the disruption. If the drive was running and using the Reference from the adapter, it will continue to run at the same Reference.

L Logic Command/Logic Status

The Logic Command is used to control the PowerFlex drive (e.g., start, stop, direction). It consists of one 16-bit word of input to the adapter from the network. The definitions of the bits in this word depend on the drive.

The Logic Status is used to monitor the PowerFlex drive (for example, operating state, motor direction). It consists of one 16-bit word of output from the adapter to the network. The definitions of the bits in this word depend on the drive.

N NVS (Non-Volatile Storage)

NVS is the permanent memory of a device. Devices such as the adapter and drive store parameters and other information in NVS so that they are not lost when the device loses power. NVS is sometimes called “EEPROM.”

P PCCC (Programmable Controller Communications Command)

PCCC is the protocol used by some controllers to communicate with devices on a network. Some software products (for example, DriveExplorer and DriveTools SP) also use PCCC to communicate.

Ping

A ping is a message that is sent by a DSI product to its peripheral devices. They use the ping to gather data about the product, including whether it can receive messages and whether they can log in for control.

PowerFlex Component Class Drives

The Allen-Bradley PowerFlex Component Class family of drives include the PowerFlex 4 and PowerFlex 40. These drives can be used for applications ranging from 0.2 kW (0.25 HP) to 7.5 kW (10 HP). All PowerFlex Component Class drives implement DSI, allowing those that support an internal adapter to use the 22-COMM-E EtherNet/IP adapter. The adapter can be installed in a PowerFlex 40 drive but not in the PowerFlex 4.

R Reference/Feedback

The Reference is used to send a Reference (for example, speed, frequency, torque) to the drive. It consists of one word of input to the adapter from the network.

Feedback is used to monitor the speed of the drive. It consists of one word of output from the adapter to the network.

RSLogix

RSLogix software is a tool for configuring and monitoring controllers to communicate with connected devices. It is a 32-bit application that runs on various Windows operating systems. Information about RSLogix software can be found at <http://www.software.rockwell.com/rslogix>.

RSNetWorx for EtherNet/IP

RSNetWorx for EtherNet/IP software is a tool for configuring and monitoring EtherNet/IP networks and connected devices. It is a 32-bit Windows application that runs on Windows 95, Windows 98, and Windows NT. Information about RSNetWorx for EtherNet/IP software can be found at <http://www.software.rockwell.com/rsnetworx>.

S Scanner

A scanner is a separate module (of a multi-module controller) or a built-in component (of a single-module controller) that provides communication with adapters connected to a network.

Status Indicators

Status indicators are LEDs that are used to report the status of the adapter, network, and drive. They are on the adapter and can be viewed on the front cover of the drive when the drive is powered.

Subnet Mask

A subnet mask is an extension to the IP addressing scheme that lets you use a single network ID for multiple physical networks. A bit mask identifies the part of the address that specifies the network and the part of the address that specifies the unique node on the network. A “1” in the subnet mask indicates the bit is used to specify the network. A “0” in the subnet mask indicates that the bit is used to specify the node.

For example, a subnet mask on a Class C address may appear as follows: 11111111 11111111 11111111 11000000 (255.255.255.192). This mask indicates that 26 bits are used to identify the network and 6 bits are used to identify devices on each network. Instead of a single physical Class C network with 254 devices, this subnet mask divides it into four networks with up to 62 devices each.

Switches

Switches are network devices that provide virtual connections that help to control collisions and reduce traffic on the network. They are able to reduce network congestion by transmitting packets to an individual port only if they are destined for the connected device. In a control application, in which real time data access is critical, network switches may be required in place of hubs.

T TCP (Transmission Control Protocol)

EtherNet/IP uses this protocol to transfer Explicit Messaging packets using IP. TCP guarantees delivery of data through the use of retries.

U UDP (User Datagram Protocol)

EtherNet/IP uses this protocol to transfer I/O packets using IP. UDP provides a simple, but fast capability to send I/O messaging packets between devices. This protocol ensures that adapters transmit the most recent data because it does not use acknowledgements or retries.

Z Zero Data

When communications are disrupted (for example, a cable is disconnected), the adapter and drive can respond with zero data. Zero data results in the drive receiving zero as values for Logic Command and Reference data. If the drive was running and using the Reference from the adapter, it will stay running but at zero Reference.

A

- Access Control parameter, **B-5**
- adapter
 - adding to an I/O configuration, **4-4**
 - applying power, **2-6**
 - commissioning, **2-1**
 - compatible products, **1-3**
 - components, **1-1**
 - definition, **G-1**
 - features, **1-2**
 - grounding, **2-4**
 - illustration, **1-1**
 - installing, **2-1 to 2-6**
 - IP address, **3-3, 3-5**
 - mounting, **2-4 to 2-5**
 - parameters, **B-1 to B-5**
 - resetting, **3-11**
 - Single/Multi-Drive mode of operation, **7-1**
 - specifications, **A-1**
 - switches, **1-1**
 - tools to configure, **3-1**
 - troubleshooting, **8-1 to 8-10**
 - web pages, **9-1**
- applying power to the adapter, **2-6**
- Assembly object, **C-4**
- attentions, **1-4**

B

- baud rate, *see data rate*
- bit definitions for Logic Command/
Status word, **D-1**
- BOOTP (Bootstrap Protocol)
 - definition, **G-1**
 - disabling, **3-5**
 - free server application, **G-1**
 - using, **3-3**
- BOOTP parameter, **B-1**

bridge

- adding to an I/O configuration, **4-2**
- definition, **G-1**
- example, **4-1**

C

- cables
 - DSI Internal Interface, **2-4**
 - EtherNet, **2-3**
- catalog number, **1-1**
- CIP, **G-1**
- classes of IP addresses, **G-5**
- Comm Fit Action parameter, **B-3**
- commissioning the adapter, **2-1**
- communications module, *see adapter*
- compatible products, **1-3**
- components, **1-1**
- configuration tools, **3-1**
- connecting adapter to the network, **2-3**
- ControlFLASH, **G-1**
- controller
 - definition, **G-1**
 - Explicit Messages, **6-4**
- ControlLogix
 - example program for Explicit Messages, **6-5**
 - example program for I/O, **5-3**
 - example program for Multi-Drive mode, **7-7 to 7-20**
 - formatting Explicit Messages, **6-2**
- D
 - data rate
 - definition, **G-2**
 - setting, **3-7**

diagnostic items
 for Multi-Drive mode, **8-7**
 for Single mode, **8-5**

dimensions, **A-1**

DPI Device object, **C-21**

DPI Diagnostic object, **C-30**

DPI Fault object, **C-28**

DPI Parameter object, **C-24**

DriveExplorer

 accessing parameters with, **3-1**
 definition, **G-2**
 free lite version, **G-2**
 supported feature, **1-2**

drives, *see PowerFlex drives*

DriveTools SP

 accessing parameters with, **3-1**
 definition, **G-2**
 supported feature, **1-2**

Drv 0 - 4 Addr parameters, **B-5**

DSI

 connector on adapter, **1-1**
 definition, **G-2**
 Internal Interface cable, **2-4**
 peripheral, **G-2**
 products, **G-2**

DSI I/O Act parameter, **B-5**

DSI I/O Cfg parameter, **B-4**

duplex

 definition, **G-3**
 selecting, **3-7**

E

EDS (Electronic Data Sheet) files
 definition, **G-3**
 web site, **G-3**

EEPROM, *see Non-Volatile Storage (NVS)*

EN Rate Act parameter, **B-3**

EN Rate Cfg parameter, **B-3**

environmental specifications, **A-2**

equipment required, **1-3**

Ethernet Link object, **C-34**

EtherNet/IP

 adapter, *see adapter*
 cable, **2-3**
 connector on adapter, **1-1**
 data rates, **A-1**
 example network, **4-1**
 network definition, **G-3**
 network switches, **G-7**
 objects, **C-1**
 specification, **G-3**

events

 clearing, **8-8**
 list of, **8-9**
 viewing, **8-8**

examples

 Explicit Messages, **6-5**
 I/O messaging, **5-3**

Explicit Messages

 about, **6-1**
 definition, **G-3**
 examples, **6-5**
 formatting, **6-2**
 running, **6-4**

F

fault action

 configuring the adapter for, **3-8**
 definition, **G-3**

fault configuration

 configuring the adapter for, **3-8**
 definition, **G-4**

faults, *see events*

features, **1-2**

firmware release, **S-i**, **P-2**

flash update, **G-4**

Flt Cfg Logic parameter, **B-4**

Flt Cfg Ref parameter, **B-4**

full duplex, *see duplex*

G

gateway, **G-4**

gateway address

setting with BOOTP, **3-3**

setting with parameters, **3-5**

Gateway Cfg 1 - 4 parameters, **B-2**

grounding the adapter, **2-4**

H

half duplex, *see duplex*

hardware address

definition, **G-4**

on label, **3-3**

HIM (Human Interface Module)

accessing parameters with, **3-1**

definition, **G-4**

using PowerFlex 4-Class HIM, **3-2**

hold last

configuring the adapter for, **3-8**

definition, **G-4**

host IDs, **G-5**

I

I/O

about, **5-1**

configuring the adapter for, **3-7**

configuring the scanner or bridge
for, **4-5**

definition, **G-5**

examples, **5-3, 7-6**

image, **5-2, 7-4**

Identity object, **C-2**

Idle Flt Action parameter, **B-4**

installation

applying power to the adapter, **2-6**

commissioning the adapter, **2-1**

connecting to the drive, **2-4**

connecting to the network, **2-3**

preparing for, **2-1**

Internal Interface cable

connecting to the adapter, **2-4**

connecting to the drive, **2-4**

illustration, **2-4**

IP Addr Cfg 1 - 4 parameters, **B-2**

IP address

definition/classes, **G-5**

setting with BOOTP, **3-3**

setting with parameters, **3-5**

L

LEDs, *see status indicators*

Logic Command/Status

bit definitions, **D-1**

definition, **G-6**

in I/O image, **5-2, 7-4**

using, **5-2**

M

MAC address, *see hardware address*

manual

conventions, **P-2**

related documentation, **P-1**

web site, **P-1**

mechanical dimensions, **A-1**

messages, *see Explicit Messages or
I/O*

MOD status indicator

locating, **8-1**

troubleshooting with, **8-3**

Mode parameter, **B-1**

modes of operation, **1-6**

mounting the adapter, **2-4 to 2-5**

Multi-Drive mode

- additional information, **7-22**
- Explicit messaging, **7-20**
- ladder logic program example, **7-6**
- setting with switch (SW1), **2-2**
- system wiring, **7-3**
- using, **7-1**
- versus Single mode, **7-1**

N

NET A status indicator

- locating, **8-1**
- troubleshooting with, **8-4**

NET B status indicator

- locating, **8-1**
- troubleshooting with, **8-5**

network IDs, **G-5**

Non-Volatile Storage (NVS)

- definition, **G-6**
- in adapter, **3-1**
- in drive, **6-1**

O

objects

- list of, **C-1 to C-35**
- using for Explicit messages, **6-3**

ODVA EtherNet/IP specification, **G-3**operating status, **1-6****P**Parameter Group object, **C-13**Parameter object, **C-9**

parameters

- accessing, **3-1**
- convention, **P-2**
- editing, **3-2**
- list of, **B-1 to B-5**
- numbers, **B-1**

PCCC, **G-6**PCCC object, **C-15**ping, **G-6**

PORT status indicator

- locating, **8-1**
- troubleshooting with, **8-2**

power consumption, **A-1**

PowerFlex drives

- 4/40 Logic Command/Status, **D-1**
- compatible with adapter, **1-3**
- definition, **G-6**
- HIM, **3-2**
- installing adapter on, **2-4**

preparing for an installation, **2-1**processor, *see controller*programmable logic controller, *see controller***Q**quick start, **1-5****R**

Reference/Feedback

- definition, **G-6**
- in I/O image, **5-2, 7-4**
- using, **5-3**

Register object, **C-6**regulatory compliance, **A-1**related documentation, **P-1**requested packet interval, **4-6**Reset Module parameter, **B-3**ribbon cable, *see Internal Interface cable*RSLinx, **P-2**

RSLogix

- adding devices to the I/O configuration, **4-2 to 4-7**
- definition, **G-7**
- saving the I/O configuration, **4-7**
- using RSLinx with, **4-7**

RSNetWorx for EtherNet/IP

definition, **G-7**

web site, **G-7**

S

safety precautions, **1-4**

scanner

adding to an I/O configuration, **4-2**

definition, **G-7**

Single mode

setting with switch (SW1), **2-2**

versus Multi-Drive mode, **7-1**

specifications

adapter, **A-1**

EtherNet/IP address, **G-5**

EtherNet/IP subnet mask, **G-7**

status indicators

definition, **G-7**

locating, **8-1**

normal operation, **1-6**

troubleshooting with, **8-1**

Subnet Cfg 1 - 4 parameters, **B-2**

subnet mask

definition, **G-7**

setting with BOOTP, **3-3**

setting with parameters, **3-5**

switches on adapter

locating, **1-1**

setting, **2-2**

T

TCP (Transmission Control Protocol),

G-8

TCP/IP Interface object, **C-32**

technical support, **P-2**

tools required, **1-3**

troubleshooting, **8-1 to 8-10**

U

UDP (User Datagram Protocol), **G-8**

update, *see flash update*

W

web pages

enabling with switch (SW2), **2-2**

for your adapter, **9-1**

web site

for DriveExplorer software, **G-2**

for DriveTools SP software, **G-2**

for EDS files, **G-3**

for EtherNet/IP, **G-3**

for manuals, **P-1**

wiring, *see cables*

Z

zero data

configuring the adapter for, **3-8**

definition, **G-8**

www.rockwellautomation.com

Power, Control and Information Solutions Headquarters

Americas: Rockwell Automation, 1201 South Second Street, Milwaukee, WI 53204-2496 USA, Tel: (1) 414.382.2000, Fax: (1) 414.382.4444

Europe/Middle East/Africa: Rockwell Automation, Vorstaan/Boulevard du Souverain 36, 1170 Brussels, Belgium, Tel: (32) 2 663 0600, Fax: (32) 2 663 0640

Asia Pacific: Rockwell Automation, Level 14, Core F, Cyberport 3, 100 Cyberport Road, Hong Kong, Tel: (852) 2887 4788, Fax: (852) 2508 1846

Publication 22COMM-UM004B-EN-P – January, 2004

P/N 319629-P02

Supersedes 22COMM-UM004A-EN-P - December, 2003

Copyright © 2004 Rockwell Automation, Inc. All rights reserved. Printed in USA.