

Safe Speed Monitor Option Module for PowerFlex® 750-Series AC Drives

Catalog Numbers 20-750-S1 Firmware Revision 1.xxx



Important User Information

Solid-state equipment has operational characteristics differing from those of electromechanical equipment. Safety Guidelines for the Application, Installation and Maintenance of Solid State Controls (publication [SGL-1.1](#) available from your local Rockwell Automation sales office or online at <http://www.rockwellautomation.com/literature/>) describes some important differences between solid-state equipment and hard-wired electromechanical devices. Because of this difference, and also because of the wide variety of uses for solid-state equipment, all persons responsible for applying this equipment must satisfy themselves that each intended application of this equipment is acceptable.

In no event will Rockwell Automation, Inc. be responsible or liable for indirect or consequential damages resulting from the use or application of this equipment.

The examples and diagrams in this manual are included solely for illustrative purposes. Because of the many variables and requirements associated with any particular installation, Rockwell Automation, Inc. cannot assume responsibility or liability for actual use based on the examples and diagrams.

No patent liability is assumed by Rockwell Automation, Inc. with respect to use of information, circuits, equipment, or software described in this manual.

Reproduction of the contents of this manual, in whole or in part, without written permission of Rockwell Automation, Inc., is prohibited.

Throughout this manual, when necessary, we use notes to make you aware of safety considerations.



WARNING: Identifies information about practices or circumstances that can cause an explosion in a hazardous environment, which may lead to personal injury or death, property damage, or economic loss.



ATTENTION: Identifies information about practices or circumstances that can lead to personal injury or death, property damage, or economic loss. Attentions help you identify a hazard, avoid a hazard, and recognize the consequence



SHOCK HAZARD: Labels may be on or inside the equipment, for example, a drive or motor, to alert people that dangerous voltage may be present.



BURN HAZARD: Labels may be on or inside the equipment, for example, a drive or motor, to alert people that surfaces may reach dangerous temperatures.

IMPORTANT Identifies information that is critical for successful application and understanding of the product.

The information below summarizes the changes to this manual since the last publication.

Topic	Page
Changed references from the PowerFlex 750-Series AC Drives User Manual to the new PowerFlex 750-Series AC Drives Programming Manual, publication 750-PM001.	throughout
Added Frame 8 drive details.	throughout
Parameter numbers added to diagrams for greater clarity.	throughout
Terminology section expanded.	12
Updated the PFD and PFH Data section with additional attributes and values,	19
Updated the Safety Reaction Time section with Frame 8 data.	20
Updated the Set Safety Enable Circuitry section with PowerFlex 753 and PowerFlex 755 details.	30

Notes:

Preface	About This Publication.....	11
	Who Should Use This Manual.....	11
	Conventions.....	11
	Terminology.....	12
	Additional Resources.....	13
	 Chapter 1	
Safety Concept	Introduction.....	15
	Safety Certification.....	15
	Important Safety Considerations.....	16
	Safety Category 4 Performance Definition.....	16
	Stop Category Definitions.....	17
	Performance Level and Safety Integrity Level (SIL) CL3.....	18
	Functional Proof Tests.....	18
	PFD and PFH Definitions.....	18
	PFD and PFH Data.....	19
	Safe State.....	19
	Safety Reaction Time.....	20
	Considerations for Safety Ratings.....	20
	Output Pulse Test Considerations.....	21
	Encoder Considerations.....	21
	Understanding Commutation.....	22
	Contact Information if Safety Option Failure Occurs.....	22
	 Chapter 2	
About the PowerFlex Safe Speed Monitor Option Module	Introduction.....	23
	Safety Functions.....	23
	Safety Modes.....	24
	Disabled Mode.....	25
	Lock Monitoring.....	25
	Safe Maximum Speed, Safe Maximum Acceleration, and Safe Direction Monitoring.....	25
	Hardware Features.....	26
	Configuration.....	27
	 Chapter 3	
Installation and Wiring	Introduction.....	29
	General Safety Information.....	29
	Power Supply Requirements.....	29
	Set Safety Enable Circuitry.....	30
	Install the PowerFlex Safety Option Module.....	31
	Terminal Connections.....	32
	Compatible Encoders.....	33
	Connect an Encoder.....	33

efesotomasyon.com

	Chapter 4	
Speed Monitoring I/O Signals	Introduction	35
	Inputs	35
	Safe Stop Input (SS_In)	38
	Safe Limited Speed Input (SLS_In)	38
	Door Monitor Input (DM_In)	38
	Enabling Switch Monitor Input (ESM_In)	39
	Lock Monitor Input (LM_In)	39
	Reset Input (Reset_In)	40
	Outputs	41
	Safe Stop Output (SS_Out)	41
Safe Limited Speed Output (SLS_Out)	42	
Door Control Output (DC_Out)	44	
	Chapter 5	
General Device and Feedback Monitoring Configuration	Introduction	47
	Cascaded Configuration	47
	Safety Mode	48
	Reset Type	48
	Overspeed Response Time	49
	Speed Resolution Accuracy for Rotary Systems	50
	Speed Resolution Accuracy for Linear Systems	52
	General Parameter List	53
	Feedback Monitoring	54
	Feedback Polarity	54
	Single Encoder	54
	Dual Encoders	55
	Feedback Voltage Monitor Range	57
	Feedback Fault	58
	Feedback Parameter List	58
	Chapter 6	
Safe Stop and Safe Stop with Door Monitoring Modes	Introduction	61
	Safe Stop Mode	61
	Safe Stop Types	62
	Standstill Speed and Position Tolerance	65
	Deceleration Monitoring	65
	Safe Stop Reset	66
	Door Control	67
	Lock Monitoring	69
	Safe Stop Parameter List	69
	Safe Stop Wiring Example	71
	Safe Stop with Door Monitoring Mode	72
	Lock Monitoring	72
	SS Reset	72
Safe Stop with Door Monitoring Parameter List	73	
Safe Stop with Door Monitoring Wiring Example	74	

Safe Limited Speed (SLS) Modes

Chapter 7

Introduction.....	75
Safe Limited Speed (SLS) Mode.....	75
Safe Limited Speed Reset.....	77
Safe Limited Speed Parameter List.....	78
Configuring the PowerFlex 750-Series Drive for SLS Operation.....	79
Safe Limited Speed Wiring Example.....	80
Safe Limited Speed with Door Monitoring Mode.....	81
Safe Limited Speed Reset.....	82
SLS with Door Monitoring Parameter List.....	82
SLS with Door Monitoring Wiring Example.....	83
Safe Limited Speed with Enabling Switch Monitoring Mode.....	83
Safe Stop Reset (SS Reset) and Safe Limited Speed Reset (SLS Reset).....	84
SLS with Enabling Switch Monitoring Parameter List.....	84
SLS with Enabling Switch Monitoring Wiring Example.....	85
Safe Limited Speed with Door Monitoring and Enabling Switch Monitoring Mode.....	86
Behavior During SLS Monitoring.....	87
Behavior While SLS Monitoring is Inactive.....	88
Behavior During SLS Monitoring Delay.....	88
Safe Stop Reset (SS Reset) and Safe Limited Speed Reset (SLS Reset).....	89
SLS with Door Monitoring and Enabling Switch Monitoring Parameter List.....	89
SLS with Door Monitoring and Enabling Switch Monitoring Wiring Example.....	90
Safe Limited Speed Status Only Mode.....	91
Speed Hysteresis.....	92
SLS Status Only Parameter List.....	93
SLS Status Only Wiring Examples.....	94

Chapter 8

Slave Modes for Multi-axis Cascaded Systems

Introduction.....	97
Cascaded Configurations.....	97
Slave, Safe Stop Mode.....	98
Slave, Safe Stop Parameter List.....	99
Slave, Safe Stop Wiring Examples.....	101
Slave, Safe Limited Speed Mode.....	104
Slave, Safe Limited Speed Parameters.....	104
Slave, Safe Limited Speed Wiring Examples.....	105
Slave, Safe Limited Speed Status Only Mode.....	107
Slave, Safe Limited Speed Status Only Parameter List.....	107
Slave, Safe Limited Speed Status Only Wiring Examples.....	108
Multi-axis Connections.....	110

Safe Maximum Speed and Direction Monitoring	Chapter 9	Introduction	113
		Safe Maximum Speed (SMS) Monitoring	113
		Safe Maximum Acceleration (SMA) Monitoring	116
		Safe Direction Monitoring (SDM)	118
		Max Speed, Max Accel, and Direction Monitoring Parameter List . . .	120
Safety Configuration and Verification	Chapter 10	Introduction	121
		Safety Configuration	121
		Configuration Signature ID	121
		Safety-lock	121
		Set and Change a Password	122
		Resetting the Password	122
		Resetting the Configuration	123
		Basics of Application Development and Testing	123
		Commissioning the System	124
		Specifying the Safety Configuration	125
		Configure the Safe Speed Monitor Option Module	126
		Project Verification Test	127
		Confirm the Project	127
		Safety Validation	127
		Verifying the Signature and Lock in the Safe Speed Monitor Option Module	127
	Editing the Configuration	128	
Configuration Examples	Chapter 11	Introduction	129
		Example Application 1	129
		Example 1: Initial Security Group Settings	130
		Example 1: General Group Settings	131
		Example 1: Feedback Group Settings	132
		Example 1: Stop Group Settings	133
		Example 1: Limited Speed Group Settings	135
		Example 1: Door Control Group Settings	136
		Example 1: Max Speed Group	137
		Example 1: Final Security Group Settings	138
		Example Application 2	139
		Example 2: Initial Security Group Settings	139
		Example 2: General Group Settings	140
		Example 2: Feedback Group Settings	142
		Example 2: Stop Group Settings	143
	Example 2: Limited Speed Group Settings	145	
	Example 2: Door Control Group Settings	146	
	Example 2: Max Speed Group	148	
	Example 2: Final Security Group Settings	149	

	Chapter 12	
Troubleshooting the PowerFlex Safety Option Module	Introduction.....	151
	Status Indicators	151
	Nonrecoverable Faults.....	152
	Fault Recovery	152
	Input and Output Faults.....	152
	Fault Codes and Descriptions	152
	Fault Reactions	155
	Safe State Faults	155
	Stop Category Faults and Fault While Stopping Faults	155
	Status Attributes	156
	Guard Status Attributes.....	156
	I/O Diagnostic Status Attributes	158
	Configuration Fault Codes.....	159
		Appendix A
Specifications	Introduction.....	161
	General Specifications	161
	Certifications	162
	Encoder Specifications.....	162
	Appendix B	
Parameter Data	Parameter Groups.....	163
	Parameters and Settings in a Linear List	164
Index		

About This Publication

This manual explains how PowerFlex 750-Series drives can be used in Safety Integrity Level (SIL) CL3, Performance Level [PLe], or Category (CAT) 4 applications. It describes the safety requirements, including PFD and PFH values and application verification information, and provides information on installing, configuring, and troubleshooting the PowerFlex Safe Speed Monitor Option module.

Who Should Use This Manual

Use this manual if you are responsible for designing, installing, configuring, or troubleshooting safety applications that use the PowerFlex Safe Speed Monitor Option module.

You must have a basic understanding of electrical circuitry and familiarity with PowerFlex 750-Series drives. You must also be trained and experienced in the creation, operation, and maintenance of safety systems.

Conventions

In this manual, configuration parameters are listed by number followed by the name in brackets. For example, P24 [OverSpd Response].

efesotomasyon.com

Terminology

This table defines abbreviations used in this manual.

Abbreviation	Full Term	Definition
1oo2	One out of Two	Refers to the behavioral design of a dual-channel safety system.
CAT	Category	—
CL	Capability Level	—
DC	Door Control	—
DM	Door Monitoring	—
EN	European Norm	The official European Standard.
ESD	Emergency Shutdown Systems	—
ESM	Enabling Switch Monitoring	—
ESPE	Electro-sensitive Protective Equipment	An assembly of devices and/or components working together for protective tripping or presence-sensing purposes and comprising as a minimum: " a sensing device. " controlling/monitoring devices. " output signal-switching devices (OSSD).
FMEA	Failure Mode and Effects Analysis	—
FV	Flux Vector	—
HFT	Hardware Fault Tolerance	The HFT equals n , where $n+1$ faults could cause the loss of the safety function. An HFT of 1 means that 2 faults are required before safety is lost.
HIM	Human Interface Module	A module used to configure a device.
IEC	International Electrotechnical Commission	—
IGBT	Insulated Gate Bi-polar Transistors	Typical power switch used to control main current.
ISO	International Organization for Standardization	—
LM	Lock Monitoring	—
MP	Motion Power	—
NC	Normally Closed	A set of contacts on a relay or switch that are closed when the relay is de-energized or the switch is de-activated.
NO	Normally Open	A set of contacts on a relay or switch that are open when the relay is de-energized or the switch is de-activated.
OSSD	Output Signal Switching Device	The component of the electro-sensitive protective equipment (ESPE) connected to the control system of a machine, which, when the sensing device is actuated during normal operation, responds by going to the OFF-state.
PC	Personal Computer	Computer used to interface with and program your safety system.
PELV	Protective Extra Low Voltage	An electrical system in which the voltage cannot exceed ELV under normal conditions, and under single-fault conditions, except earth faults in other circuits.
PFD	Probability of Failure on Demand	The average probability of a system to fail to perform its design function on demand.
PFH	Probability of Failure per Hour	The probability of a system to have a dangerous failure occur per hour.
PL	Performance Level	ISO 13849-1 safety rating
PM	Permanent Magnet	—
PTI	Proof Test Interval	—
SDM	Safe Direction Monitoring	—
SELV	Safety Extra Low Voltage Circuit	A secondary circuit which is so designed and protected that, under normal and single fault conditions, its voltages do not exceed a safe value.
SFF	Safe Failure Fraction	The sum of safe failures plus the sum of dangerous detected failures divided by the sum of all failures.
SIL	Safety Integrity Level	A measure of a products ability to lower the risk that a dangerous failure could occur.
SLS	Safe Limited Speed	—
SMA	Safe Maximum Acceleration	—
SMS	Safe Maximum Speed	—
SS	Safe Stop	—

Additional Resources

These documents contain additional information concerning related Rockwell Automation products.

Resource	Description
PowerFlex 750-Series AC Drive Installation Instructions, publication 750-IN001	Provides information on installing the safety option module in your PowerFlex 750-Series drive.
PowerFlex 750-Series AC Drives Programming Manual, publication 750-PM001	Provides information on mounting, installing, and configuring your PowerFlex 750-Series drive.
Enhanced PowerFlex 7-Class Human Interface Module (HIM) User Manual, publication 20HIM-UM001	Provides information on using the 20-HIM-A6 HIM module to configure the PowerFlex 750-Series drive and safety option module.
DriveExplorer Online Help	DriveExplorer online help provides information on the release, quick start steps, general information about DriveExplorer software, descriptions of the elements in the DriveExplorer window, step-by-step procedures, and troubleshooting information.
PowerFlex 750-Series Safe Torque Off User Manual, publication 750-UM002	Provides information on installing and configuring your Safe Torque Off module with PowerFlex 750-Series drives.
System Design for Control of Electrical Noise Reference Manual, publication GMC-RM001	Information, examples, and techniques designed to minimize system failures caused by electrical noise.
EMC Noise Management DVD, publication GMC-SP004	
Safety Guidelines for the Application, Installation and Maintenance of Solid State Control, publication SGI-1.1	Describes important differences between solid state control and hardwired electromechanical devices.

You can view or download publications at <http://www.rockwellautomation.com/literature>. To order paper copies of technical documentation, contact your local Rockwell Automation distributor or sales representative.

Notes:

Safety Concept

Introduction

This chapter describes the safety performance level concept and how the PowerFlex 750-Series drives can meet the requirements for SIL CL3, CAT 4, or PLe applications.

Topic	Page
Safety Certification	15
Functional Proof Tests	18
PFD and PFH Definitions	18
Safe State	19
Safety Reaction Time	20
Considerations for Safety Ratings	20
Contact Information if Safety Option Failure Occurs	22

Safety Certification

The PowerFlex 750-Series safety option is certified for use in safety applications up to and including SIL CL3 according to EN 61800-5-2, EN 61508, and EN 62061, Performance Level PLe and CAT 4 according to ISO 13849-1. Safety requirements are based on the standards current at the time of certification.

The TÜV Rheinland group has approved the PowerFlex 750-Series safety option for use in safety-related applications where the de-energized state is considered to be the safe state. All of the examples related to I/O included in this manual are based on achieving de-energization as the safe state for typical Machine Safety and Emergency Shutdown (ESD) systems.

efesotomasyon.com

Important Safety Considerations

The system user is responsible for:

- the setup, safety rating, and validation of any sensors or actuators connected to the system.
- completing a system-level risk assessment and reassessing the system any time a change is made.
- certification of the system to the desired safety performance level.
- project management and proof testing.
- programming the application software and the safety option configurations in accordance with the information in this manual.
- access control to the system, including password handling.
- analyzing all configuration settings and choosing the proper setting to achieve the required safety rating.

IMPORTANT When applying functional safety, restrict access to qualified, authorized personnel who are trained and experienced.



ATTENTION: When designing your system, consider how personnel will exit the machine if the door locks while they are in the machine. Additional safeguarding devices may be required for your specific application.

Safety Category 4 Performance Definition

To achieve Safety Category 4 according to ISO 13849-1:2006, the safety-related parts have to be designed such that:

- the safety-related parts of machine control systems and/or their protective equipment, as well as their components, shall be designed, constructed, selected, assembled, and combined in accordance with relevant standards so that they can withstand expected conditions.
- basic safety principles shall be applied.
- a single fault in any of its parts does not lead to a loss of safety function.
- a single fault is detected at or before the next demand of the safety function, or, if this detection is not possible, then an accumulation of faults shall not lead to a loss of the safety function.
- the average diagnostic coverage of the safety-related parts of the control system shall be high, including the accumulation of faults.
- the mean time to dangerous failure of each of the redundant channels shall be high.
- measures against common cause failure shall be applied.

Stop Category Definitions

The selection of a stop category for each stop function must be determined by a risk assessment.

- Stop Category 0 is achieved with immediate removal of power to the actuator, resulting in an uncontrolled coast to stop. Safe Torque Off accomplishes a Stop Category 0 stop.
- Stop Category 1 is achieved with power available to the machine actuators to achieve the stop. Power is removed from the actuators when the stop is achieved.
- Stop Category 2 is a controlled stop with power available to the machine actuators. The stop is followed by a holding position under power.

Refer to Safe Stop Mode on [page 61](#) for more information.

IMPORTANT When designing the machine application, timing and distance should be considered for a coast to stop (Stop Category 0 or Safe Torque Off). For more information regarding stop categories, refer to EN 60204-1.

Performance Level and Safety Integrity Level (SIL) CL3

For safety-related control systems, Performance Level (PL), according to ISO 13849-1, and SIL levels, according to EN 61508 and EN 62061, include a rating of the system's ability to perform its safety functions. All of the safety-related components of the control system must be included in both a risk assessment and the determination of the achieved levels.

Refer to the ISO 13849-1, EN 61508, and EN 62061 standards for complete information on requirements for PL and SIL determination.

Refer to [Chapter 10](#) for more information on the requirements for configuration and verification of a safety-related system containing the PowerFlex 750-Series drives.

Functional Proof Tests

The functional safety standards require that functional proof tests be performed on the equipment used in the system. Proof tests are performed at user-defined intervals and are dependent upon PFD and PFH values.

IMPORTANT Your specific application determines the time frame for the proof test interval.

PFD and PFH Definitions

Safety-related systems can be classified as operating in either a Low Demand mode, or in a High Demand/Continuous mode.

- Low Demand mode: where the frequency of demands for operation made on a safety-related system is no greater than one per year or no greater than twice the proof-test frequency.
- High Demand/Continuous mode: where the frequency of demands for operation made on a safety-related system is greater than once per year or greater than twice the proof test interval.

The SIL value for a low demand safety-related system is directly related to order-of-magnitude ranges of its average probability of failure to satisfactorily perform its safety function on demand or, simply, average probability of failure on demand (PFD). The SIL value for a High Demand/Continuous mode safety-related system is directly related to the probability of a dangerous failure occurring per hour (PFH).

PFD and PFH Data

These PFD and PFH calculations are based on the equations from Part 6 of EN 61508 and show worst-case values.

This table provides data for a 20-year proof test interval and demonstrates the worst-case effect of various configuration changes on the data.

Table 1 - PFD and PFH for 20-year Proof Test Interval

Attribute	Value	
	Drive Frames 2...7	Drive Frame 8
PFD	2.35E-4	5.83E-4
PFH	2.67E-9 1/h	6.75E-9 1/h
SFF	99.5%	98.4%
DC	High	Medium (98%)
SIL CL	3	3
PL	e	e
CAT.	4	4
HFT	1 (1002)	1 (1002)
PTI (Proof Test Interval)	20 years	20 years

Safe State

The Safe State encompasses all operation that occurs outside of the other monitoring and stopping behavior defined as part of the safety option. In addition, configuration takes place in the Safe State. While the safety option is in the Safe State, all safety control outputs, except the Door Control (DC_Out) output, are in their safe state (de-energized). The Door Control (DC_Out) output will be in either the locked state or in the de-energized state depending upon the condition that resulted in the safe state.

When you cycle power, the safety option enters the Safe State for self-testing. If the self-tests pass and there is a valid configuration, the safety option remains in the Safe State until a successful request for safe speed monitoring occurs.

If a Safe State fault is detected, the safety option goes to the Safe State. This includes faults related to integrity of hardware or firmware.

For more information on faults, refer to [Chapter 12](#).

Safety Reaction Time

The safety reaction time is the amount of time from a safety-related event as input to the system until the system is in the Safe State.

The safety reaction time from an input signal condition that triggers a safe stop, to the initiation of the configured Stop Type, is:

- 20 ms (maximum) for drive Frames 2...7
- 20.8 ms (maximum) for drive Frame 8

The safety reaction time from an overspeed event that triggers a safe stop, to the actual initiation of the configured Stop Type, is equal to the value of the P24 [OverSpd Response] parameter.

For more information on overspeed response time, see Overspeed Response Time on [page 49](#).

Considerations for Safety Ratings

The achievable safety rating of an application that uses the safety option installed in PowerFlex 750-Series drives is dependent upon many factors, including the encoder setup, drive options, output pulse testing, and the type of motor.

When using two independent encoders to monitor motion and when installed in a manner to avoid any common cause dangerous failure, the PowerFlex safety option can be used in applications up to and including SIL CL3, PLe, and CAT 4.

For applications that rely on commutation to generate torque and motion, a safety rating up to and including SIL CL3, PLe, and CAT 4 can be achieved.

IMPORTANT Some of the diagnostics performed on the encoder signals require motion to detect faults. You must make sure that motion occurs at least once every six months.

Output Pulse Test Considerations

If the pulse testing of *any* safety output is disabled, the maximum safety rating will be up to and including SIL CL2, PL(d), and CAT 3 for any safety chain incorporating *any input or output* of the safety option.

IMPORTANT Setting any of the P72 [SS Out Mode], P73 [SLS Out Mode], or P74 [DC Out Mode] parameters to 1 = No Pulse Test disables internal diagnostics as well as external diagnostics required to achieve higher safety ratings. You must exercise the SS_In input at least once every six months.

You may need to disable pulse-testing if the connected device does not support OSSD inputs. Refer to the product documentation for your connected device.

Encoder Considerations

When configured correctly, the safety option performs these diagnostics on the encoder:

- $\text{Sin}^2 + \text{Cos}^2$ diagnostic
- Detection of open or short-circuit
- Encoder supply voltage monitoring
- Detection of illegal quadrature transitions of the sine and cosine signals

You can use motors that use a single-encoder application if they meet the following criteria:

- Motor is a Permanent magnet (PM) brushless AC motor
- Motor controller utilizes the single encoder for control of IGBT firing (commutation)
- Controller is not configured for auto transition to encoderless commutation in the event of encoder failure
- Encoder is of the Sin / Cos type
- Motor / Encoder coupling is designed so as to exclude shaft slippage as a failure mechanism (optional – such as tapered fittings)

Understanding Commutation

Permanent magnet (PM), brushless AC motors are a class of synchronous motor that depends on electronic brushless commutation for their operation. In PM brushless motors, an electromagnetic field is created by the permanent magnets on the rotor. A rotating magnetic field is created by a number of electromagnets commutated electronically with IGBT's at the right speed, order, and times. Movement of the electromagnetic field is achieved by switching the currents in the coils of the stator winding. This process is called commutation. Interaction of the two electromagnetic fields produces magnetic force or torque.

For example, with the PowerFlex 755 drive, follow these guidelines to make sure that the incremental encoder or high-resolution feedback device is used for commutation:

- Set P35 [Motor Cntl Mode] = 1 "Induction FV" or 6 "PM FV"
- Set P125 [Pri Vel Fdbk Sel] = any available feedback device
- Set P635 [Spd Options Ctrl] bit 7 "Auto Tach SW" = 0

Contact Information if Safety Option Failure Occurs

If you experience a failure with any safety-certified device, contact your local Rockwell Automation distributor. With this contact, you can:

- return the device to Rockwell Automation so the failure is appropriately logged for the catalog number affected and a record is made of the failure.
- request a failure analysis (if necessary) to determine the probable cause of the failure.

About the PowerFlex Safe Speed Monitor Option Module

efesotomasyon.com

Introduction

This chapter describes the safety option features of the PowerFlex 750-Series drives.

Topic	Page
Safety Functions	23
Hardware Features	26
Configuration	27

Safety Functions

The PowerFlex 750-Series speed-monitoring safety option features five inputs, three sets of safety outputs, and one bipolar safety output. Each of the inputs support a specific safety function.

- Safe Stop (SS)
- Safe Limited Speed Monitoring (SLS)
- Door Monitoring (DM)
- Enabling Switch Monitoring (ESM)
- Lock Monitoring (LM)

An additional reset input provides for reset and monitoring of the safety circuit.

The safety option can be used in single-axis or multi-axis applications, and can be configured as a master or slave based on its location in the system.

Safety Modes

Parameter 21 [Safety Mode] is used to configure the safety option to operate in one of 11 user-selectable safety modes, based on combinations of the safety functions listed on the previous page.

P21 Option	Mode – Description	Page
0	Disabled – In this mode, all safety functions are disabled.	25
1	Safe Stop – The safety option activates the configured Safe Stop Type upon deactivation of the Safe Stop input or the occurrence of a Stop Category fault.	61
2	Safe Stop with Door Monitoring – In addition to monitoring for Safe Stop, the safety option monitors the status of the door.	72
3	Safe Limited Speed – In addition to monitoring for Safe Stop, the safety option monitors the feedback velocity and compares it to a configurable Safe Speed Limit. If the velocity exceeds the limit, the safety option initiates the configured Safe Stop Type.	75
4	Safe Limited Speed with Door Monitoring – In addition to monitoring for Safe Stop and Safe Limited Speed, the safety option monitors the status of the door.	81
5	Safe Limited Speed with Enabling Switch Control – In addition to monitoring for Safe Stop and Safe Limited Speed, the safety option monitors the status of the Enabling Switch input.	83
6	Safe Limited Speed with Door Monitor and Enabling Switch – In addition to monitoring for Safe Stop and Safe Limited Speed, the safety option monitors the status of the door and the Enabling Switch input.	86
7	Safe Limited Speed (status only) – In addition to monitoring for Safe Stop, the safety option monitors the feedback velocity and compares it to a configurable Safe Speed Limit. If the velocity exceeds the limit, the system status is made available as a safe output intended for a safety programmable logic controller. No stopping action takes place.	91
8	Slave, Safe Stop – The safety option performs the same functions as Safe Stop. However, it regards the Door Monitor input as a Door Control output from an upstream axis, and performs a logical AND with its internal Door Control signal to form the cascaded Door Control output.	98
9	Slave, Safe Limited Speed – The safety option performs the same functions as Safe Limited Speed mode. However, it regards the Door Monitor input as a Door Control output from an upstream axis, and performs a logical AND with its internal Door Control signal to form the cascaded Door Control output.	104
10	Slave, Safe Limited Speed (status only) – The safety option performs the same functions as Safe Limited Speed Status Only mode. However, it regards the Door Monitor input as a Door Control output from an upstream axis, and performs a logical AND with its internal Door Control signal to form the cascaded Door Control output.	107

IMPORTANT The Safe Speed Monitor option must be used with the 20-750-DENC-1 Dual Incremental Encoder module of the 20-750-UFB-1 Universal Feedback module.

Disabled Mode

When P21 [Safety Mode] = 0 “Disabled” and P6 [Operating Mode] = 1 “Run” all safety functions are disabled. Input, output, or speed monitoring diagnostics do not take place and all outputs are in their safe state. Motion power is enabled for drive commissioning in this mode.

IMPORTANT The safety option monitors motion for Safe Stop in every mode except Disabled.

Lock Monitoring

Lock monitoring helps prevent access to the hazard during motion. In many applications, it is not sufficient for the machine to initiate a stop command once the door has been opened because a high inertia machine may take a long time to stop. Preventing access to the hazard until a safe speed has been detected may be the safest condition. The lock monitoring feature is used to verify the operation of the door locking mechanism.

Lock monitoring can be enabled on single units or on the first unit in a multi-axis system. If the Lock Monitor input (LM_In) indicates that the door is unlocked when the Door Control output (DC_Out) is in the locked state, or if the Lock Monitor input indicates locked when the Door Monitor input (DM_In) transitions from closed to open, the configured Safe Stop Type is initiated.

Safe Maximum Speed, Safe Maximum Acceleration, and Safe Direction Monitoring

Three additional safety functions, Safe Maximum Speed (SMS), Safe Maximum Acceleration (SMA) and Safe Direction Monitoring (SDM), operate independent of the other modes, relying on the Safe Stop function. When you configure the safety option for Safe Maximum Speed, the feedback velocity is monitored and compared against a user-configurable limit. If the measured velocity is greater than or equal to the limit, the configured Safe Stop Type is executed.

When Safe Acceleration Monitoring is enabled, the option monitors the acceleration rate and compares it to a configured Safe Maximum Acceleration Limit. If acceleration is detected as greater than or equal to the Safe Maximum Acceleration Limit, an Acceleration fault occurs. If an Acceleration fault is detected while the option is actively monitoring motion, the configured Safe Stop Type is initiated.

Safe Direction Monitoring is also activated via option configuration. The option monitors the feedback direction and executes the configured Safe Stop Type when motion in the illegal direction is detected.

Refer to [Chapter 9](#) for detailed information on these functions.

Hardware Features

The safety option features five dual-channel inputs, two sets of sourcing safety outputs, and one bipolar safety output. You can configure dual-channel inputs to accept a following-contact configuration with two normally closed contacts, or one normally closed and one normally open contact. They can also be configured for single channel operation.

IMPORTANT Single-channel operation does not meet SIL CL3, PLe, Cat 4 safety integrity.

These inputs also support output signal switching devices (OSSD). Each output has integral pulse-test checking circuitry.

Figure 1 - PowerFlex 750-Series Safety Option Module

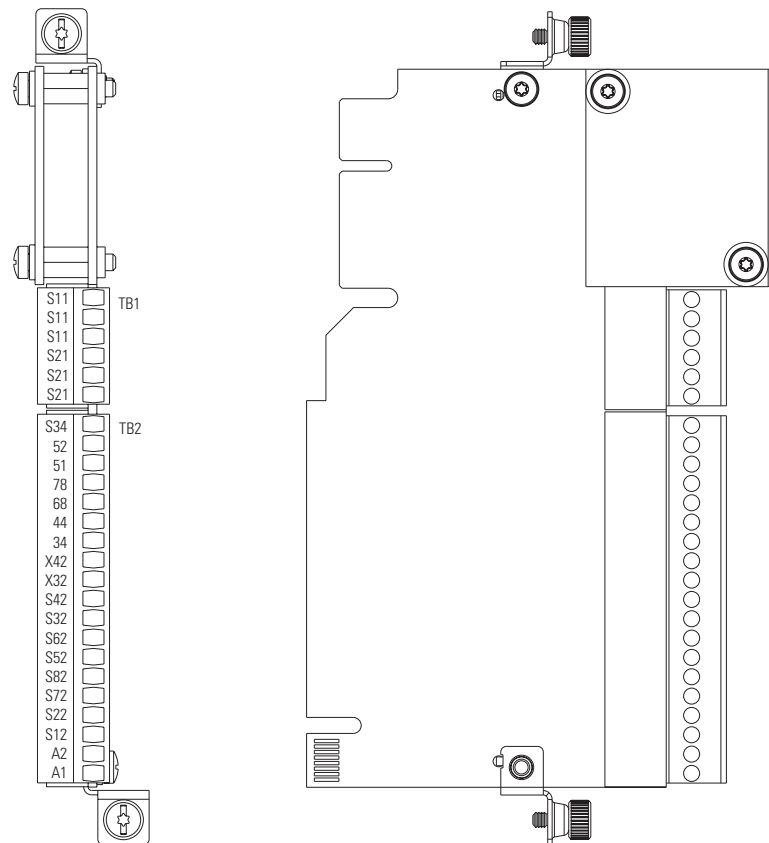

Configuration

Configure the PowerFlex 750-Series safety option by setting the configuration parameters with a HIM module. You can also use DriveExplorer or DriveExecutive software.

Drive	DriveExplorer	DriveExecutive
PowerFlex 753	Version 6.03 or later	Version 5.03 or later
PowerFlex 755	Version 6.01 or later	Version 5.01 or later

All of these configuration tools let you save the configuration and download it to another PowerFlex 750-Series drive. Only DriveExecutive software lets you edit the configuration offline.

When the safety option configuration is complete, it can be safety-locked to prevent unauthorized changes to the safety configuration. If you set a password to protect the safety configuration, you must enter the password before you can lock or unlock the configuration. Refer to [Chapter 10](#) for instructions on setting up and resetting passwords.

If you are using a HIM or DriveExplorer/Drive Executive software to configure the safety option, refer to the PowerFlex 750-Series Drives Programming Manual, publication [750-PM001](#).

Notes:

Installation and Wiring

Introduction

This chapter provides details on connecting devices and wiring the PowerFlex safety option board.

Topic	Page
General Safety Information	29
Power Supply Requirements	29
Set Safety Enable Circuitry	30
Install the PowerFlex Safety Option Module	31
Terminal Connections	32
Compatible Encoders	33
Connect an Encoder	33



ATTENTION: The safety option is intended to be part of the safety-related control system of a machine. Before installation, a risk assessment should be performed to determine whether the specifications of this safety option are suitable for all foreseeable operational and environmental characteristics for the system to which it is to be installed.

General Safety Information

Observe all electrical safety regulations stipulated by the appropriate technical authorities.



ATTENTION: Make sure that the electrical power supplied to the PowerFlex 750-Series drive is switched off before installing the safety option or making connections.

Refer to the PowerFlex 750-Series AC Drive Installation Instructions, publication [750-IN001](#), for more information.

Power Supply Requirements

The external power supply must conform to the Directive 2006/95/EC Low Voltage, by applying the requirements of EN61131-2 Programmable Controllers, Part 2 - Equipment Requirements and Tests and one of the following:

- EN60950 - SELV (Safety Extra Low Voltage)
- EN60204 - PELV (Protective Extra Low Voltage)
- IEC 60536 Safety Class III (SELV or PELV)
- UL 508 Limited Voltage Circuit
- 24V DC $\pm 10\%$ must be supplied by a power supply that complies with IEC/EN60204 and IEC/EN 61558-1.

For planning information, refer to the guidelines in Industrial Automation Wiring and Grounding Guidelines, publication [1770-4.1](#).

Set Safety Enable Circuitry

The PowerFlex 750-Series drive ships with the safety-enable jumper (SAFETY) installed. The jumper, located on the main control board, must be removed when using the Safe Speed Monitor Option module.

IMPORTANT Failure to remove the SAFETY jumper will cause the drive to fault when a start command is issued.

Figure 2 - PowerFlex 753 - SAFETY Jumper Location

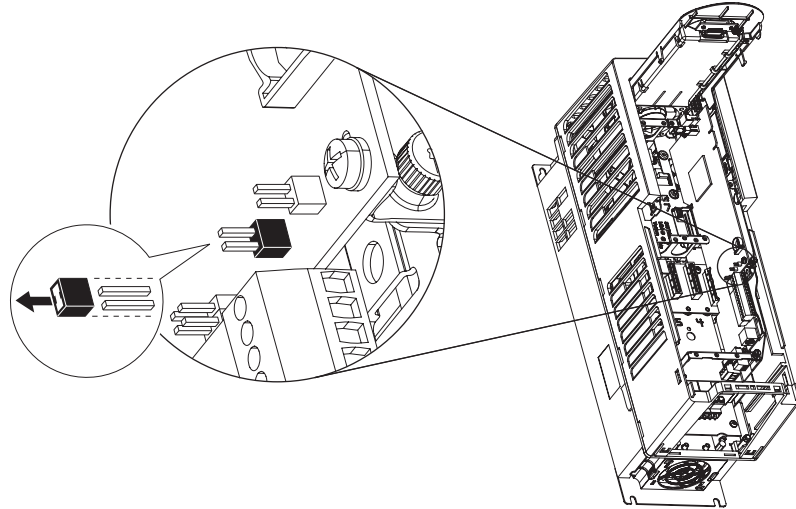
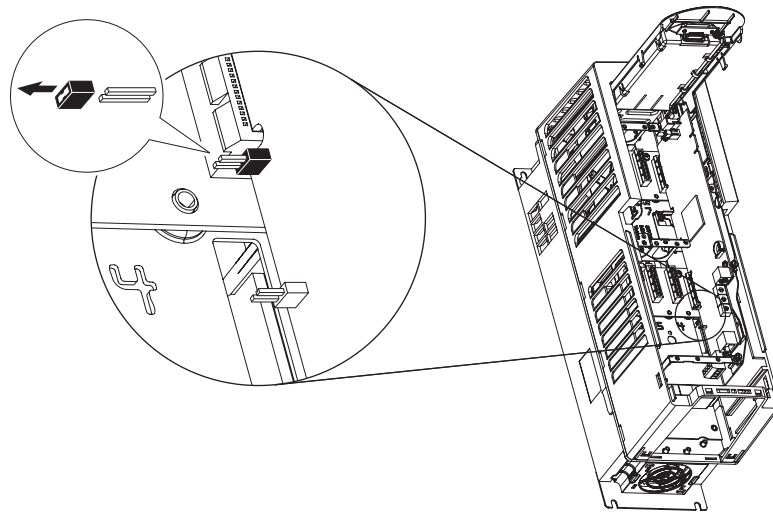

Figure 3 - PowerFlex 755 - SAFETY Jumper Location (Frames 2...7 Only)



Note: Frame 8 drives do not have a safety enable jumper.

TIP The Di0 digital output on the main control board can be designated as a "hardware enable" function by removing the ENABLE jumper. If this jumper is removed, the drive will not run unless the Di0 digital input is activated. The Di0 input is not related to the operation of the safety option. If you are not using the Di0 input as a 'hardware enable' do not remove the ENABLE jumper.

Install the PowerFlex Safety Option Module

There are multiple option module port positions in PowerFlex 750-Series drives. Restrictions and/or recommendations apply to selected option modules.

IMPORTANT The PowerFlex safety option module must be installed in port 4, 5, or 6 and must be used with the 20-750-DENC-1 Dual Incremental Encoder module or the 20-750-UFB-1 Universal Feedback module.

When used in an Integrated Motion application, the Safe Speed Monitor option must be installed in port 6.



ATTENTION: Hazard of equipment damage exists if an option module is installed or removed while the drive has power applied. To avoid damaging the drive, verify that the voltage on the bus capacitors has discharged before performing any work on the drive. Refer to the PowerFlex 750-Series AC Drive Installation Instructions, publication [750-IN001](#), for more information.

Follow these steps to install the PowerFlex safety option.

1. Firmly press the option module edge connector into the desired option module port.
2. Tighten the top and bottom retaining screws.
 - Recommended torque = 0.45 N•m (4.0 lb•in)
 - Recommended screwdriver = T15 Hexalobular

IMPORTANT Do not over-tighten retaining screws.

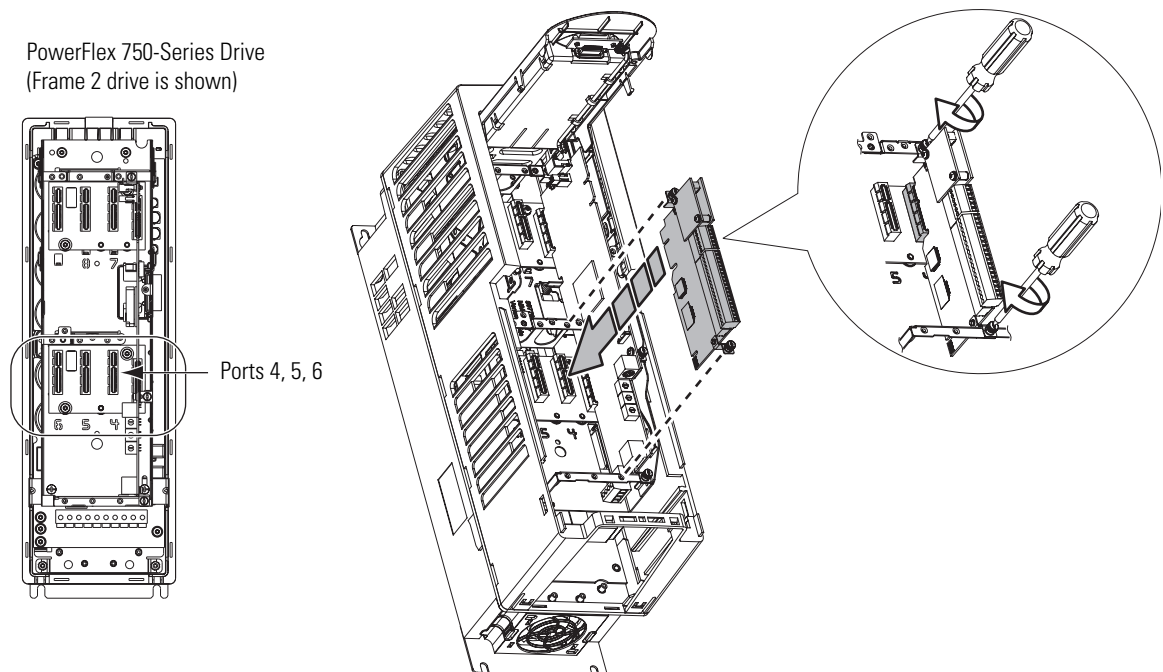

Terminal Connections

Prepare wires for termination on the safety option module with a 6 mm (0.25 in.) strip length. Tighten all terminal screws firmly and recheck them after all connections have been made. Recommended terminal screw torque is 0.2 N•m (1.8 lb•in).

Refer to [page 161](#) for the I/O signal electrical specifications.

Table 2 - Safety Option Module TB1 Pinouts

Terminal	Description	Signal Name
S11	Pulse Test	TEST_OUT_0
S11	Pulse Test	TEST_OUT_0
S11	Pulse Test	TEST_OUT_0
S21	Pulse Test	TEST_OUT_1
S21	Pulse Test	TEST_OUT_1
S21	Pulse Test	TEST_OUT_1

Table 3 - Safety Option Module TB2 Pinouts

Terminal	Description	Signal Name
S34	Reset Input	RESET_IN
52	Door Control Output	DC_OUT_CH1
51	Door Control Output	DC_OUT_CH0
78	Safe Limited Speed Output	SLS_OUT_CH1
68	Safe Limited Speed Output	SLS_OUT_CH0
44	Safe Stop Output	SS_OUT_CH1
34	Safe Stop Output	SS_OUT_CH0
X42	Lock Monitoring Input	LM_IN_CH1
X32	Lock Monitoring Input	LM_IN_CH0
S42	Door Monitoring Input	DM_IN_CH1
S32	Door Monitoring Input	DM_IN_CH0
S62	Safe Limited Speed Input	SLS_IN_CH1
S52	Safe Limited Speed Input	SLS_IN_CH0
S82	Enabling Switch Monitoring Input	ESM_IN_CH1
S72	Enabling Switch Monitoring Input	ESM_IN_CH0
S22	Safe Stop Input	SS_IN_CH1
S12	Safe Stop Input	SS_IN_CH0
A2	Common, customer supplied	24V_COM
A1	+24V DC, customer supplied	+24V

Compatible Encoders

These feedback devices, or equivalents, are supported.

Cat. No. and Description		Additional Resources
Sin/Cos Encoders ⁽¹⁾	842HR-xJxxx15FWYx	Refer to the Bulletin 842HR Sin/Cosine Encoders product profile, publication 842HR-PP001 , for more information on these encoders.
Incremental Encoders ⁽²⁾	845T-xx12xxx-x and 845T-xx13xxx-x 845T-xx42xxx and 845T-xx43xxx-x 845T-xx52xxx and 845T-xx53xxx-x	Refer to the Sensors Reference Catalog, publication C116 , for catalog number, dimensions, and specifications for Bulletin 845T and 845H Incremental Encoders.
	845H-SJxxx4xxYxx	
Rotary Motors	1326AB-Bxxx-M2L/S2L	Refer to the Kinetix Motion Control Selection Guide, publication GMC-SG001 , for more information on these motors.
	MP-Series motors with embedded Sin/Cos or incremental encoders	
	Any motor with SRS-60 Stegmann encoder	Refer to the product documentation for your specific motor to determine the encoder type.
	Any motor with SRM-60 Stegmann encoder	
	Any motor with SHS-170 Stegmann encoder	
	Any motor with SCS-60 Stegmann encoder	
	HPK-Series Asynchronous Servo Motor	
	Any motor with SCS-Kit 101 Stegmann encoder	
Any motor with SRS660 Stegmann encoder	Refer to the product documentation for your specific motor to determine the encoder type.	

(1) Maximum cable length for sin/cos encoders is 90 m (295 ft).

(2) Maximum cable length for incremental encoders is 183 m (600 ft) when using 12V or 30.5 m (100 ft) when using 5V.

Connect an Encoder

The PowerFlex 750-Series safety option uses feedback that is connected to a 20-750-DENC-1 Dual Incremental Encoder module or a 20-750-UFB-1 Universal Feedback module.

Refer to the PowerFlex 750-Series AC Drive Installation Instructions, publication [750-IN001](#), for information on how to connect encoders to these option modules.

IMPORTANT The 20-750-DENC-1 Dual Incremental Encoder module and the 20-750-UFB-1 Universal Feedback module have specified jumper or slider settings to enable use with the Safe Speed Monitor option module.

Notes:

Speed Monitoring I/O Signals

Introduction

This chapter describes the input and output signals of the Safe Speed Monitor Option module.

Topic	Page
Inputs	35
Outputs	41

Inputs

The safety option has five inputs capable of safety-certified dual-channel support. Each dual-channel input supports a specific safety function of the drive: Safe Stop, Safe Limited Speed, Door Monitoring, Enabling Switch Monitoring, and Lock Monitoring.

All five inputs are electrically identical and rely on the same pair of pulse test outputs, Test_Out_0 and Test_Out_1, when not using the OSSD configuration.

The inputs can be configured for one of the following settings:

- 1 = Dual-channel equivalent (2 Normally Closed)
- 2 = Dual-channel equivalent 3 s (2 Normally Closed 3 Seconds)
- 3 = Dual-channel complementary (1 Normally Closed + 1 Normally Open)
- 4 = Dual-channel complementary 3 s (1 Normally Closed + 1 Normally Open 3 Seconds)
- 5 = Dual-channel SS equivalent 3 s (2 Output Signal Switching Devices 3 Seconds)
- 6 = Single Channel

IMPORTANT Single-channel configuration (1NC) is not SIL CL3, PLe, Cat 4.

When configured for dual-channel operation, the consistency between the two channels is evaluated. For dual-channel equivalent configurations, the active state for both channel 0 and channel 1 is ON. For dual-channel complementary configurations, the active state for channel 0 is ON and the active state for channel 1 is OFF. Any time both channels are not active, the input pair is evaluated as OFF.

When both channels are active, if one channel's input terminal transitions from active to inactive and back to active, while the other channel's input terminal remains active, both channels must go inactive at the same time before the evaluated status may return to ON. This condition is called 'cycle inputs required'.

Figure 4 - Cycle Inputs Required

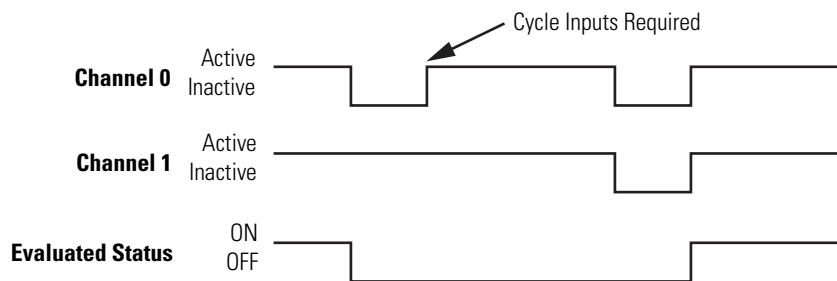

If inputs are configured with the following dual channel settings, an Input fault occurs if the inputs are discrepant for longer than 3 seconds or if a 'cycle inputs required' condition exists for longer than 3 seconds.

- 2 = Dual-channel equivalent 3 s (2NC 3s)
- 4 = Dual-channel complementary 3 s (1NC + 1NO 3s)
- 5 = Dual-channel SS equivalent 3 s (2 OSSD 3s)

If inputs are configured with one of the following dual channel settings, which have no limit on the length of time that inputs can be discrepant, an Input fault will not occur for any discrepant condition or for any "cycle inputs required" condition.

- 1 = Dual-channel equivalent (2NC)
- 3 = Dual-channel complementary (1NC + 1NO)

For all input settings except Dual-channel SS equivalent 3 s (2 OSSD 3s), if one or two channels are connected to a 24V DC source other than terminals S11 and S21, a fault occurs.

I/O faults are Stop Category faults, which initiate the configured Safe Stop Type. I/O faults are latched until the safety option is successfully reset.

For more information on I/O faults, refer to Troubleshooting the PowerFlex Safety Option Module on [page 151](#).

When using a dual-channel complementary (1NC + 1NO) device, the normally-open input must be connected to the second input, as shown in the illustration. For example, if the door is open when the input is ON, the normally-open contact must be the second input (Input 1).

Figure 5 - Safety Input Wiring Examples

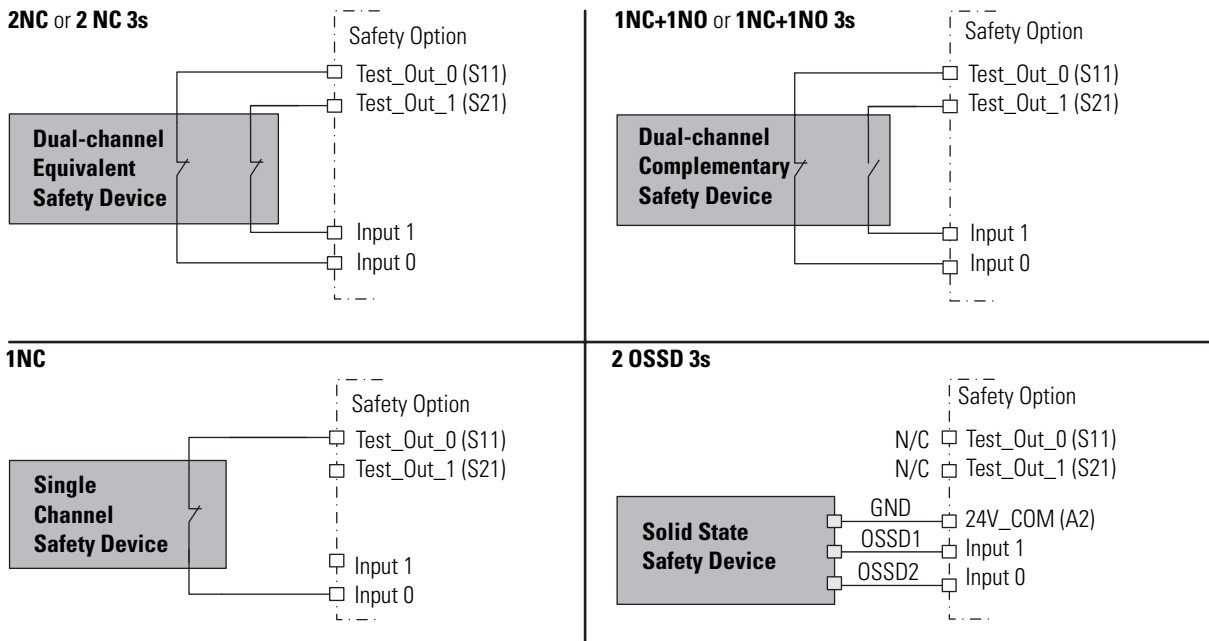

IMPORTANT Cross wiring of Test Outputs to Inputs is not allowed. For example, do not connect TEST_OUT_0 to Input 1 or TEST_OUT_1 to Input 0.

Table 4 - Safety Option Input Terminals

Function	Safe Stop (SS_In)	Safe Limited Speed (SLS_In)	Door Monitoring (DM_In)	Enabling Switch Monitoring (ESM_In)	Lock Monitoring (LM_In)
Input 0 = Channel 0	S12	S52	S32	S72	X32
Input 1 = Channel 1	S22	S62	S42	S82	X42

Short-circuits of the input loop to ground or 24V will be detected. For dual-channel inputs, cross loops will also be detected.

Safe Stop Input (SS_In)

The SS_In input is intended for connection to an E-Stop device.

The SS_In input must be active to initiate Safe Stop monitoring. If the SS_In input is being monitored, a transition from ON to OFF (closed to open) is used to request the configured Safe Stop Type.

In a cascaded configuration, the SS_In inputs of the middle and last drives are connected to the Safe Stop (SS_Out) output of an upstream safety option.

Safe Limited Speed Input (SLS_In)

The SLS_In input is used to connect to a switch whose OFF state requests Safe Limited Speed monitoring.

If Safe Limited Speed monitoring is configured, the SLS_In input is monitored from the time of a successful Safe Stop Reset or Safe Limited Speed Reset, until the time that the configured Safe Stop Type is initiated or the Safe State is entered.

If the SLS_In input is being monitored, the OFF state is used to request the Safe Limited Speed monitoring functionality of the safety option.

In a cascaded configuration, the SLS_In inputs of the middle and last drives are connected to the Safe Limited Speed (SLS_Out) output of an upstream safety option.

Door Monitor Input (DM_In)

This input monitors the status of the door to indicate if it is open or closed. The DM_In input can be connected to a non-guardlocking switch if the door does not need to be locked. The door status is monitored by the first unit in multi-axis systems.

The DM_In input is intended for connection to a guardlocking switch when the safety option is configured as a master device with door monitoring. When the safety option is configured as a slave in a cascaded system, its DM_In input is connected to the Door Control output (DC_Out) of the upstream safety option.

Refer to Door Control Output (DC_Out) on [page 44](#) for more information.

Enabling Switch Monitor Input (ESM_In)

The ESM_In input is intended to be connected to an enabling switch. A 440J-N21TNPM enabling switch is recommended. The safety option uses the ESM_In input as a safety enable only, not for control. The ESM_In inputs function and monitoring is performed by the first unit in multi-axis systems.

The ESM_In input ON state is used to enable motion under mode-specific conditions in the Safety Limited Speed with Enabling Switch (Lim Speed ES) and Safe Limited Speed with Door Monitoring and Enabling Switch Monitoring (LimSpd DM ES) modes.

Refer to Safe Limited Speed with Door Monitoring Mode on [page 81](#) and Safe Limited Speed with Door Monitoring and Enabling Switch Monitoring Mode on [page 86](#) for the conditions that must be true to start monitoring the ESM_In input.

If the ESM_In input is OFF while it is being monitored, an ESM Monitoring fault (Stop Category Fault) occurs and the safety option initiates the configured Safe Stop Type.

Refer to [Chapter 12](#) for information on faults and how to recover from them.

Lock Monitor Input (LM_In)

The LM_In input verifies that the guardlocking solenoid switch is locked. It is intended to confirm the door control function.

The LM_In input is monitored by the first unit in multi-axis systems.

Reset Input (Reset_In)

The Reset input is for reset and monitoring of the safety circuit. The reset input can be configured for automatic, manual, or manual monitored reset types.

Wire the reset input terminal (TB2-S34) to the 24V DC input terminal, (TB2-A1), depending on the configured reset type, as shown.

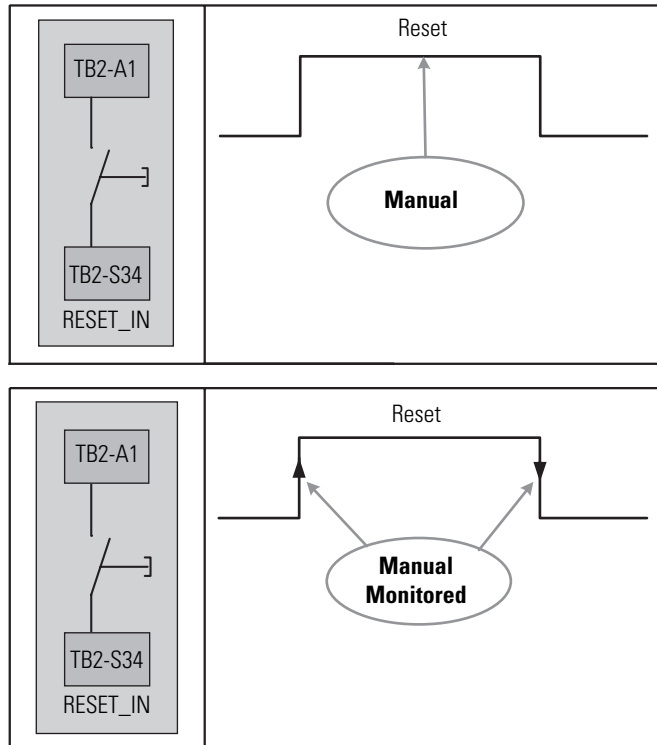

IMPORTANT If you configure the safety option for automatic reset, wiring of the reset input terminal (TB2-S34) is not required.

Outputs

The safety option has three safety control outputs. The outputs have various output current capabilities, depending on function.

See the specifications in [Appendix A](#) to verify your power requirements.

Safe Stop Output (SS_Out)

The safe state for this signal is OFF.

These outputs are typically used in multi-axis applications. In multi-axis applications, you can use these outputs to daisy-chain the master safety option to a slave.

For SS_Out to SS_In cascaded signals, the interface is a dual-channel sourcing solid-state safety output connected to a dual-channel safety input configured as OSSD. The outputs are pulse-tested when the P72 [SS Out Mode] parameter is configured for pulse-testing.

IMPORTANT If you disable pulse-testing on this output, the achievable SIL, Category, and PL ratings of your entire safety system are reduced.

Figure 6 - SS_Out to SS_In Connections for Multi-axis Applications

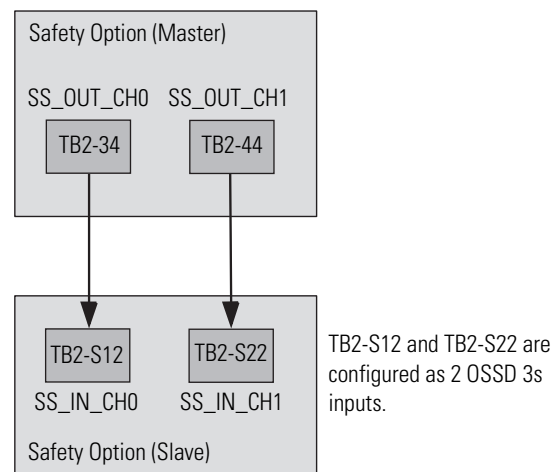

For more information on multi-axis configurations, see Cascaded Configurations starting on [page 97](#).

Alternately, the first SS_Out output may be used to signal a programmable logic controller (PLC) that a Safe Stop has been requested.

If the SS_In is ON (closed) and a successful Safe Stop Reset is performed, the SS_Out output is turned ON. If Lock Monitoring is not enabled or the door control logic state is Unlock, the SS_Out signal turns ON immediately when the SS_In turns ON. If Lock Monitoring is enabled, and the door control logic state

is Lock, the SS_Out signal is not turned ON until the door has been locked by using the DC_Out signal and the LM_In input has been verified as ON.

If the Safe Stop Type is initiated or if a Safe Stop is initiated due to a fault, the SS_Out output is turned OFF.

If an error is detected on either channel of the dual-channel output, a fault occurs. I/O faults are Stop Category faults, which initiate the configured Safe Stop Type. The fault is latched until the safety option is successfully reset.

For more information on faults, refer to [Chapter 12](#).

Safe Limited Speed Output (SLS_Out)

The safe state for this signal in all cases is OFF.

The SLS_Out output functionality is determined by the configured Safety mode. If the SLS_In is ON and a successful Safe Stop or Safe Limited Speed reset is performed, the SLS_Out turns ON in all Safe Limited Speed modes except Safe Limited Speed Status Only.

For the Safe Limited Speed modes (SLS), the SLS_Out is used to interconnect speed monitoring safety options in multi-axis applications. For SLS_Out to SLS_In cascaded signals, the interface is a dual-channel sourcing solid state safety output connected to a dual-channel safety input configured as OSSD. The outputs are read back and pulse-tested when the P73 [SLS Out Mode] parameter is configured for pulse-testing.

IMPORTANT If you disable pulse-testing on this output, the achievable SIL, Category, and PL ratings of your entire safety system are reduced.

For a single unit system or the last unit in a cascaded system, the SLS_Out is intended to be connected to an input of a safety programmable logic controller (PLC). The same PLC could also control the Safe Stop function with a safe PLC output connected to the Safe Stop input (SS_In).

For the first or middle units in a cascaded system, the SLS_Out is intended to be connected to the Safe Limited Speed input (SLS_In) of the next safety option in the cascaded system. This lets one SLS switch enable Safe Limited Speed on all axes at the same time.

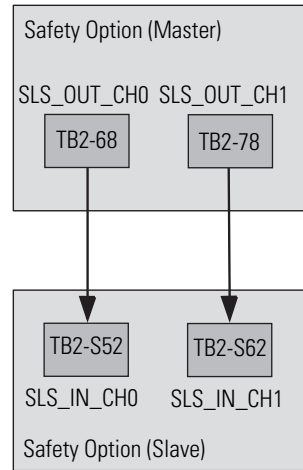
Figure 7 - SLS_Out to SLS_In Connections for Multi-axis Applications

For more information on multi-axis configurations, see Cascaded Configurations starting on [page 97](#).

For Safe Limited Speed Status Only modes, the SLS_Out output is used as an indication that the Safe Limited Speed monitoring is active and the monitored speed is less than the configured Safe Speed Limit. If the speed is greater than or equal to the Safe Speed Limit, the SLS_Out is turned OFF. When Safe Limited Speed monitoring is not active or the safety option is in a SLS Monitoring Delay [LimSpd Mon Delay], the SLS_Out output is OFF. The SLS_Out output is turned OFF when a Safe Stop has been initiated, a fault has occurred, or the safety option is in the safe state.

See Safe Limited Speed Status Only Mode on [page 91](#) for more information.

If an error is detected on either channel of the dual-channel output, a fault occurs. I/O faults are Stop Category faults, which initiate the configured Safe Stop Type. The fault is latched until the safety option is successfully reset.

For more information on faults, refer to [Chapter 12](#).

Door Control Output (DC_Out)

You can use this output for door control in single-axis and multi-axis systems. This output attempts to maintain last state when a fault occurs.

The DC_Out output is updated based on door control logic status, the P57 [Door Out Type] parameter setting, and any Safe State faults that may be detected.

This output is Unlocked only when motion is verified to be at Standstill Speed or Safe Limited Speed.

Figure 8 - Door Control and Lock Monitoring

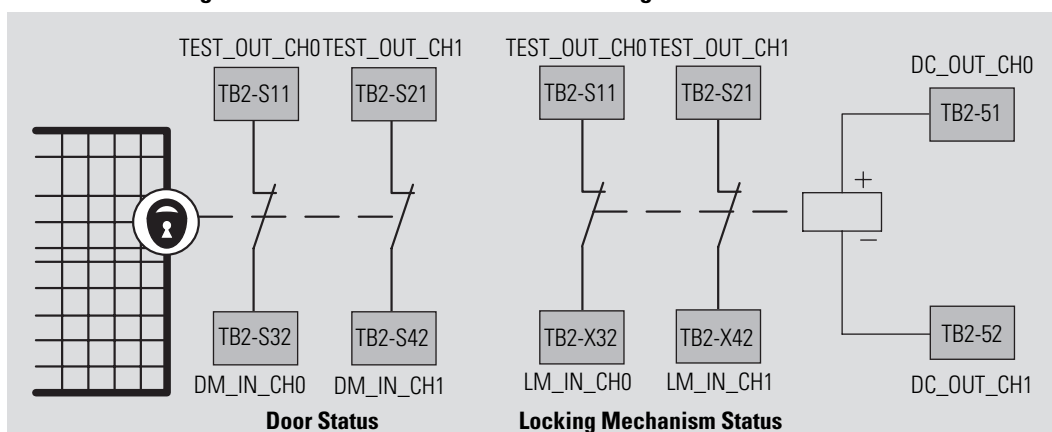

TIP Check your interlock switch for internal jumpers before installation.

If an error is detected on either channel of the dual-channel output, a fault occurs. I/O faults are Stop Category faults, which initiate the configured Safe Stop Type. The fault is latched until the safety option is successfully reset.

For more information on faults, refer to [Chapter 12](#).

The DC_Out output may be used as a bipolar output in Power to Release or Power to Lock configurations, or it may be configured as Cascading (2Ch Sourcing).

When the Door Control output is configured as cascading (2Ch Sourcing), the dual-channel bipolar output acts as two sourcing outputs capable of driving the OSSD Door Monitor input (DM_In) of the next speed monitoring safety option in the cascaded chain. The DC_out output can also be used as a source for general purpose inputs. In this configuration, the current is limited to 20 mA.

Figure 9 - Door Control Cascading Outputs

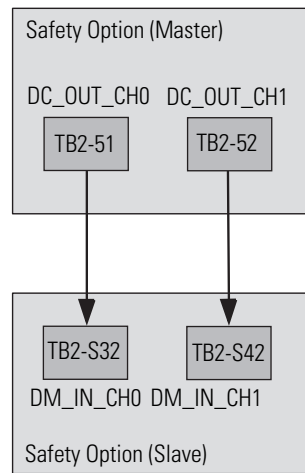

Only these wiring configurations, shown below, are supported for the Door Control output.

Figure 10 - Door Control Output Wiring

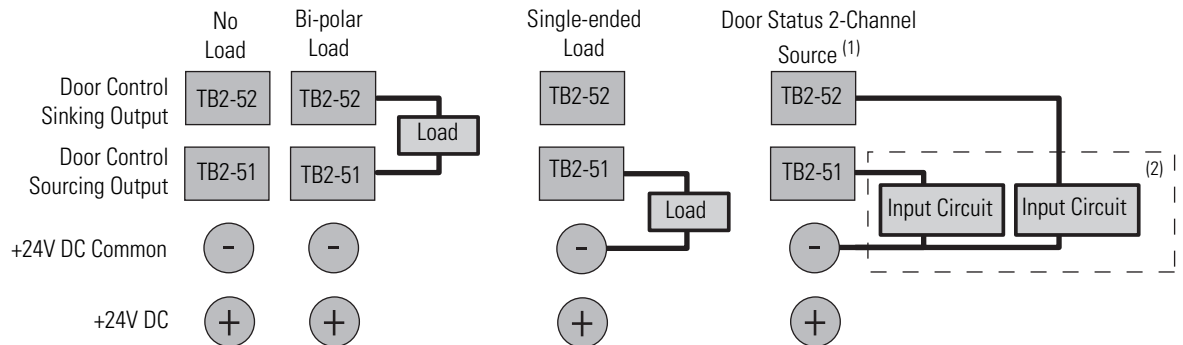

(1) When wired as a source for a safety input, current is limited to 20 mA per output.
 (2) For example, SmartGuard 600 controller, Guard I/O module.

Short-circuits of the output loop to ground or 24V will be detected. For cascaded outputs, cross loops will also be detected.

The outputs are pulse-tested when the P74 [Door Out Mode] parameter is configured for pulse-testing.

IMPORTANT If you disable pulse-testing on this output, the achievable SIL, Category, and PL ratings of your entire safety system are reduced.

Notes:

General Device and Feedback Monitoring Configuration

Introduction

This chapter describes the general and feedback configuration settings that must be configured to operate the safe speed monitor option module.

Topic	Page
Cascaded Configuration	47
Safety Mode	48
Reset Type	48
Overspeed Response Time	49
General Parameter List	53
Feedback Monitoring	54
Feedback Parameter List	58

Cascaded Configuration

The safety option may be used in single-axis or multi-axis applications. The P20 [Cascaded Config] parameter indicates the safety option's location in the system: Single Unit (Single), Cascaded First Unit (Multi First), Cascaded Middle Unit (Multi Mid), or Cascaded Last Unit (Multi Last). Single unit and cascaded first options are system masters.

Refer to [Chapter 8](#) for more information on cascaded configurations.

Safety Mode

You can configure the safety option to operate in one of 11 user-selectable Safety modes, based on combinations of the safety functions the option supports. The modes, except for Disabled, are described in detail in subsequent chapters of this manual.

For these modes	See
Master, Safe Stop (Safe Stop)	Chapter 6 , Safe Stop and Safe Stop with Door Monitoring Modes
Master, Safe Stop with Door Monitoring (Safe Stop DM)	
Master, Safe Limited Speed (Lim Speed)	Chapter 7 , Safe Limited Speed (SLS) Modes
Master, Safe Limited Speed with Door Monitoring (Lim Speed DM)	
Master, Safe Limited Speed with Enabling Switch Control (Lim Speed ES)	
Master, Safe Limited Speed with Door Monitor and Enabling Switch (LimSpd DM ES)	
Master, Safe Limited Speed Status Only (Lim Spd Stat)	
Slave, Safe Stop (Slv Safe Stp)	Chapter 8 , Slave Modes for Multi-axis Cascaded Systems
Slave, Safe Limited Speed (Slv Lim Spd)	
Slave, Safe Limited Speed Status Only (Slv Spd Stat)	

Reset Type

You can configure the P22 [Reset Type] parameter as automatic, manual, or manual monitored. The default is manual monitored. The configured Reset Type applies to both Safe Stop and Safe Limited Speed Resets.

TIP The Reset input does not require wiring for automatic reset configurations.

See Safe Stop Reset on [page 66](#) and [page 72](#), and Safe Limited Speed Reset on [page 77](#), [page 82](#), and [page 84](#) for details on how the P22 [Reset Type] parameter affects Safe Stop and Safe Limited Speed operation.



ATTENTION: For all types of reset (automatic, manual, or manual monitored), if a reset of the Safe Stop or Safe Limited Speed functions can result in machine operation, the other speed monitoring functions must be configured to detect and prevent dangerous motion.



ATTENTION: The Safe Stop Reset does not provide safety-related restart according to EN 60204-1. Restart must be performed by external measures if automatic restart could result in a hazardous situation. You are responsible for determining whether automatic restart could pose a hazard.

Overspeed Response Time

The P24 [OverSpd Response] parameter setting determines the maximum reaction time from an overspeed event to the initiation of the configured P45 [Safe Stop Type]. The safety reaction time from an overspeed event that triggers a Safe Stop Type, to the actual initiation of that Safe Stop Type, is equal to the value of the P24 [OverSpd Response] parameter. The configurable options are 42, 48, 60, 84, 132, 228, and 420 ms.

The P24 [OverSpd Response] parameter setting also determines the speed resolution that can be achieved. The Overspeed Response Time and the encoder resolution affect the speed resolution accuracy as shown in the tables on the following pages.

For example, an encoder resolution of 128 and Overspeed Response Time of 42 ms results in a speed resolution accuracy of ±19.865 RPM if your Safe Maximum Speed is configured for 100.0 RPM. An SMS Speed fault may occur when encoder 1 is at 80.135 RPM. However, the SMS Speed fault may not occur until encoder 1 reaches 119.865 RPM.



If your encoder resolution is not listed in the tables, use these equations.

For rotary systems, the conversion from Overspeed Response Time [OverSpd Response] to Speed Resolution in revolutions per minute is:

$$\text{Speed Resolution (RPM)} = \frac{15000}{(\text{OverSpd Response} - 36) \times \text{Feedback Resolution}} + \frac{\text{Speed (RPM)} \times 0.02}{(\text{OverSpd Response} - 36)}$$

For linear systems, the conversion from Overspeed Response Time [OverSpd Response] to mm/s is:

$$\text{Speed Resolution (mm/s)} = \frac{250}{(\text{OverSpd Response} - 36) \times \text{Feedback Resolution}} + \frac{\text{Speed (RPM)} \times 0.02}{(\text{OverSpd Response} - 36)}$$

Speed Resolution Accuracy for Rotary Systems

Table 5 - Encoder Resolution 16 lines/rev

Overspeed Response Time, P24 (OverSpd Response) Setting	Speed (RPM)					
	1	10	100	1000	10,000	100,000
42	156.253	156.283	156.583	159.583	189.583	489.583
48	78.127	78.142	78.292	79.792	94.792	244.792
60	39.063	39.071	39.146	39.896	47.396	122.396
84	19.532	19.535	19.573	19.948	23.698	61.198
132	9.766	9.768	9.786	9.974	11.849	30.599
228	4.883	4.884	4.893	4.987	5.924	15.299
420	2.441	2.442	2.447	2.493	2.962	7.650

Table 6 - Encoder Resolution 128 lines/rev

Overspeed Response Time, P24 (OverSpd Response) Setting	Speed (RPM)					
	1	10	100	1000	10,000	93,750
42	19.535	19.565	19.865	22.865	52.865	332.031
48	9.767	9.782	9.932	11.432	26.432	166.016
60	4.884	4.891	4.966	5.716	13.216	83.008
84	2.442	2.446	2.483	2.858	6.608	41.504
132	1.221	1.223	1.242	1.429	3.304	20.752
228	0.610	0.611	0.621	0.715	1.652	10.376
420	0.305	0.306	0.310	0.357	0.826	5.188

Table 7 - Encoder Resolution 1000 lines/rev

Overspeed Response Time, P24 (OverSpd Response) Setting	Speed (RPM)					
	1	10	100	1000	10,000	12,000
42	2.503	2.533	2.833	5.833	35.833	42.500
48	1.252	1.267	1.417	2.917	17.917	21.250
60	0.626	0.633	0.708	1.458	8.958	10.625
84	0.313	0.317	0.354	0.729	4.479	5.313
132	0.156	0.158	0.177	0.365	2.240	2.656
228	0.078	0.079	0.089	0.182	1.120	1.328
420	0.039	0.040	0.044	0.091	0.560	0.664

Table 8 - Encoder Resolution 1024 lines/rev

Overspeed Response Time, P24 (OverSpd Response) Setting	Speed (RPM)					
	1	10	100	1000	10,000	11,718.75
42	2.445	2.475	2.775	5.775	35.775	41.504
48	1.222	1.237	1.387	2.887	17.887	20.752
60	0.611	0.619	0.694	1.444	8.944	10.376
84	0.306	0.309	0.347	0.722	4.472	5.188
132	0.153	0.155	0.173	0.361	2.236	2.594
228	0.076	0.077	0.087	0.180	1.118	1.297
420	0.038	0.039	0.043	0.090	0.559	0.648

Table 9 - Encoder Resolution 3000 lines/rev

Overspeed Response Time, P24 (OverSpd Response) Setting	Speed (RPM)				
	1	10	100	1000	4000
42	0.837	0.867	1.167	4.167	14.167
48	0.418	0.433	0.583	2.083	7.083
60	0.209	0.217	0.292	1.042	3.542
84	0.105	0.108	0.146	0.521	1.771
132	0.052	0.054	0.073	0.260	0.885
228	0.026	0.027	0.036	0.130	0.443
420	0.013	0.014	0.018	0.065	0.221

Table 10 - Encoder Resolution 5000 lines/rev

Overspeed Response Time, P24 (OverSpd Response) Setting	Speed (RPM)				
	1	10	100	1000	2400
42	0.503	0.533	0.833	3.833	8.500
48	0.252	0.267	0.417	1.917	4.250
60	0.126	0.133	0.208	0.958	2.125
84	0.063	0.067	0.104	0.479	1.063
132	0.031	0.033	0.052	0.240	0.531
228	0.016	0.017	0.026	0.120	0.266
420	0.008	0.008	0.013	0.060	0.133

Speed Resolution Accuracy for Linear Systems

Table 11 - Encoder Resolution 500 lines/mm

Overspeed Response Time, P24 (OverSpd Response) Setting	Speed (mm/s)					
	0.01	0.1	1	10	100	400
42	0.083	0.084	0.087	0.117	0.417	1.417
48	0.042	0.042	0.043	0.058	0.208	0.708
60	0.021	0.021	0.022	0.029	0.104	0.354
84	0.010	0.010	0.011	0.015	0.052	0.177
132	0.005	0.005	0.005	0.007	0.026	0.089
228	0.003	0.003	0.003	0.004	0.013	0.044
420	0.001	0.001	0.001	0.002	0.007	0.022

Table 12 - Encoder Resolution 1000 lines/mm

Overspeed Response Time, P24 (OverSpd Response) Setting	Speed (mm/s)					
	0.01	0.1	1	10	100	200
42	0.042	0.042	0.045	0.075	0.375	0.708
48	0.021	0.021	0.023	0.038	0.188	0.354
60	0.010	0.011	0.011	0.019	0.094	0.177
84	0.005	0.005	0.006	0.009	0.047	0.089
132	0.003	0.003	0.003	0.005	0.023	0.044
228	0.001	0.001	0.001	0.002	0.012	0.022
420	0.001	0.001	0.001	0.001	0.006	0.011

Table 13 - Encoder Resolution 5000 lines/mm

Overspeed Response Time, P24 (OverSpd Response) Setting	Speed (mm/s)				
	0.01	0.1	1	10	40
42	0.008367	0.008667	0.011667	0.041667	0.141667
48	0.004183	0.004333	0.005833	0.020833	0.070833
60	0.002092	0.002167	0.002917	0.010417	0.035417
84	0.001046	0.001083	0.001458	0.005208	0.017708
132	0.000523	0.000542	0.000729	0.002604	0.008854
228	0.000261	0.000271	0.000365	0.001302	0.004427
420	0.000131	0.000135	0.000182	0.000651	0.002214

Table 14 - Encoder Resolution 20,000 lines/mm

Overspeed Response Time, P24 (OverSpd Response) Setting	Speed (mm/s)			
	0.01	0.1	1	10
42	0.002117	0.002417	0.005417	0.035417
48	0.001058	0.011208	0.002708	0.017708
60	0.000529	0.000604	0.001354	0.008854
84	0.000265	0.000302	0.000677	0.004427
132	0.000132	0.000151	0.000339	0.002214
228	0.000066	0.000076	0.000169	0.001107
420	0.000033	0.000038	0.000085	0.000553

General Parameter List

Set these parameters to configure general operation of the safety option.

File	Group	No.	Display Name Full Name Description	Values	Read-Write	Data Type
HOST GROUPS	General	20	Cascaded Config Cascaded Configuration Defines whether the speed monitoring safety option is a single unit or if it occupies a first, middle, or last position in a multi-axis cascaded system. "Single" (0) - Single Unit System "Multi First" (1) - Cascaded System First Unit "Multi Mid" (2) - Cascaded System Middle Unit "Multi Last" (3) - Cascaded System Last Unit	Default: 0 = "Single" Options: 0 = "Single" 1 = "Multi First" 2 = "Multi Mid" 3 = "Multi Last"	RW	Real
		21	Safety Mode Safety Mode Defines the primary operating mode of the speed monitoring safety functions. "Safe Stop" (1) - Master, Safe Stop "Safe Stop DM" (2) - Master, Safe Stop with Door Monitoring "Lim Speed" (3) - Master, Safe Limited Speed "Lim Speed DM" (4) - Master, Safe Limited Speed with Door Monitoring "Lim Speed ES" (5) - Master, Safe Limited Speed with Enabling Switch Control "LimSpd DM ES" (6) - Master, Safe Limited Speed with Door Monitoring and Enabling Switch Control "Lim Spd Stat" (7) - Master, Safe Limited Speed Status Only "Slv Safe Stp" (8) - Slave, Safe Stop "Slv Lim Spd" (9) - Slave, Safe Limited Speed "Slv Spd Stat" (10) - Slave, Safe Limited Speed Status Only	Default: 1 = "Safe Stop" Options: 0 = "Disabled" 1 = "Safe Stop" 2 = "Safe Stop DM" 3 = "Lim Speed" 4 = "Lim Speed DM" 5 = "Lim Speed ES" 6 = "LimSpd DM ES" 7 = "Lim Spd Stat" 8 = "Slv Safe Stp" 9 = "Slv Lim Spd" 10 = "Slv Spd Stat"	RW	Real
		22	Reset Type Reset Type Defines the type of reset used by the safety option.	Default: 2 = "Monitored" Options: 0 = "Automatic" 1 = "Manual" 2 = "Monitored" (Manual Monitored)	RW	Real
		24	OverSpd Response Over Speed Response Configuration for the feedback interface sampling rate.	Default: 0 = "42 ms" Options: 0 = "42 ms" 1 = "48 ms" 2 = "60 ms" 3 = "84 ms" 4 = "132 ms" 5 = "228 ms" 6 = "420 ms"	RW	Real

Feedback Monitoring

The P27 [Fbk Mode] parameter defines whether the feedback monitoring devices are configured as a single encoder or as dual encoders. When two encoders are used, the P27 [Fbk Mode] parameter also defines the type of discrepancy checking that is performed between the two encoders.

IMPORTANT Feedback device 1 can be a Sin/Cos or incremental feedback device. Feedback device 2 can only be an incremental feedback device.

You choose the type of feedback device, either sine/cosine or incremental for encoder 1 by using the P28 [Fbk 1 Type] parameter. You also choose the feedback type, resolution, and polarity of both encoders.

Configure the feedback type as rotary or linear by using the [Fbk x Units] parameter. Configure the resolution in lines per revolution or lines per millimeter by using the [Fbk x Resolution] parameter. In these parameter names the x is '1' for encoder 1 and '2' for encoder 2.

For dual encoder configurations, the resolution of the first encoder may be different than the resolution of the second encoder. After discrepancy testing has passed, the speed, relative position, and direction used by the safety option are based on encoder 1.

IMPORTANT For dual encoder configurations, the resolution of the first encoder may be different than the resolution of the second encoder, but it must be equal to or higher than the resolution of the second encoder.

Feedback Polarity

Configure the direction of polarity to be the same as the encoder or reversed by using the P30 [Fbk 1 Polarity] parameter. The safety option defines the normal positive direction for encoders as A leading B. To use encoders where B leads A, you must enter 1 for the P30 [Fbk 1 Polarity] parameter. Set the P35 [Fbk 2 Polarity] parameter so that the resulting speed direction is of the same polarity as encoder 1.

Single Encoder

If the P27 [Fbk Mode] parameter is set to 1 Encoder, the single encoder input is processed redundantly and cross-checked in a 1oo2 architecture. The speed, direction, and stopped status are derived from the single encoder by the 1oo2 architecture.

Refer to Considerations for Safety Ratings, on [page 20](#), for more information.

Dual Encoders

If the P27 [Fbk Mode] parameter is set to 2 Encoders, each encoder input is processed by a single channel and cross-checked in a 1oo2 architecture. Discrepancy checking is performed between the two encoders. After the discrepancy checks have passed, the speed, direction, and stopped status are derived from encoder 1.

IMPORTANT All monitoring functions are based on the speed of encoder 1. The encoder 2 signal is used for fault diagnostics.

Speed and direction checks are affected by these parameters:

- Dual Feedback Speed Ratio, P39 [Fbk Speed Ratio]
- Dual Feedback Position Tolerance, P41 [Fbk Pos Tol]
- Dual Feedback Speed Discrepancy Tolerance, P40 [Fbk Speed Tol]

Dual Feedback Speed Ratio

The Dual Feedback Speed Ratio, P39 [Fbk Speed Ratio] parameter, is defined as the ratio of the expected speed of encoder 2 divided by the expected speed of encoder 1. This parameter configures the anticipated gearing between encoder 1 and encoder 2.

$$\frac{\text{Dual Feedback Speed Ratio}}{\text{P39 [Fbk Speed Ratio] Parameter}} = \frac{\text{Expected Speed of Encoder 2}}{\text{Expected Speed of Encoder 1}}$$

If P27 [Fbk Mode] equals 0 (1 encoder), the only legal value for P39 [Fbk Speed Ratio] parameter is 0.0.

If P27 [Fbk Mode] is greater than 0, the range of legal values for P39 [Fbk Speed Ratio] is from 0.0001...10,000.0.

For example, if encoder 2's speed is expected to be 1000 revolutions per second while encoder 1's speed is expected to be 100 revolutions per second, then the P39 [Fbk Speed Ratio] should be configured as 10.0.

The units used to measure encoder speed are configurable as either rotary (rev) or linear (mm) units. Any combination of rotary and linear units for the two encoders is allowed.

Dual Feedback Position Discrepancy Tolerance

The Dual Feedback Position Discrepancy Tolerance, P41[Fbk Pos Tol] parameter defines the cumulative position discrepancy that will be tolerated between encoder 1 and encoder 2. The position discrepancy is defined as position change relative to encoder 1.

IMPORTANT The relative position discrepancy difference is reset to zero at each Safe Stop Reset.

This discrepancy checking is performed only while the [Fbk Mode] parameter is equal to one of these values.

Feedback Mode, P27 [Fbk Mode] Parameter Settings

1	Dual encoder with speed and position discrepancy checking
3	Dual encoder with position discrepancy checking

This table defines the legal values for each Feedback mode value.

Feedback Mode, P27 [Fbk Mode] Values		Dual Feedback Position Discrepancy Tolerance, P41 [Fbk Pos Tol] Legal Values
0	One encoder	0
1	Dual encoder with speed and position discrepancy	1...65,535 in degrees (rotary encoders) or mm (linear encoders) relative to the resolution of encoder 1
2	Dual encoder with speed discrepancy checking	0
3	Dual encoder with position discrepancy checking	1...65,535 in degrees (rotary encoders) or mm (linear encoders) relative to the resolution of encoder 1

If an illegal value is detected, an Invalid Configuration fault occurs and the safety option remains in the Safe State.

IMPORTANT When setting discrepancy tolerances, consider that configuring a high gear ratio between encoder 1 and encoder 2 could lead to unexpected dual feedback position faults. This is because a very large encoder 1 movement would translate into a very small encoder 2 movement.

Dual Feedback Speed Discrepancy Tolerance

The Dual Feedback Speed Discrepancy Tolerance P40 [Fbk Speed Tol], defines the discrepancy that will be tolerated for a difference in speed between encoder 1 and encoder 2. This speed is relative to encoder 1. This discrepancy checking is performed only while the Feedback mode is equal to one of these values.

Feedback Mode, P27 [Fbk Mode] Parameter Settings	
1	Dual encoder with speed and position discrepancy checking
2	Dual encoder with speed discrepancy checking

For rotary systems, the value is specified in revolutions per minute. For linear systems, the value is specified in mm per second.

Feedback Mode, P27 [Fbk Mode] Parameter Values	Dual Feedback Speed Discrepancy Tolerance, P40 [Fbk Speed Tol] Parameter Values	
0	One encoder	0
1	Dual encoder with speed and position discrepancy checking	0.1 ... 6553.5 in rev/min (rotary encoders) or mm/s (linear encoders)
2	Dual encoder with speed discrepancy checking	0.1 ... 6553.5 in rev/min (rotary encoders) or mm/s (linear encoders)
3	Dual encoder with position discrepancy checking	0

If an illegal value is detected, an Invalid Configuration fault occurs and the safety option remains in the Safe State.

Feedback Voltage Monitor Range

Use the P32 [Fbk 1 Volt Mon] and P37 [Fbk 2 Volt Mon] parameters to set the feedback voltage monitoring range. The monitoring ranges help define the trip zone for encoder 1 and encoder 2, respectively.

Fbk x Volt Mon Setting	5	9	12	14	
Range	4.5...5.5V	7...12V	11...14V	11.5...15V	
Trip Zone	< 4.5V	< 7V	< 11V	< 11.5V	
The encoder must be specified to operate across this complete range or larger.	May Trip	4.5...4.75V	7...7.4V	11...11.6V	11.5...12.25V
	No Trip	4.75...5.25V	7.4...11.4V	11.6...13.3V	12.25...14.75V
	May Trip	5.25...5.5V	11.4...12.0V	13.3...14.0V	14.75...15.5V
	Trip Zone	>5.5V	> 12.0V	>14.0V	>15.5V

Your power supply must stay within the No Trip range.

Feedback Fault

The allowable frequency of feedback input signals is limited. The safety option monitors feedback signals whenever its configuration is valid and the Safety mode is not configured as Disabled.

Encoder Type	Maximum Frequency
Sine/cosine	≤ 100 kHz
Incremental	≤ 200 kHz

If the feedback signals indicate greater than or equal to the maximum value, a Feedback_x fault (Safe State fault) occurs.
(x equals 1 or 2 depending upon which encoder has the fault.)

Diagnostics are performed on the encoder input signals. If the encoder diagnostic tests fail, a Feedback_x fault (Safe State fault) occurs.

Feedback Parameter List

To define the type of feedback used by the safety option, set these parameters.

File	Group	No.	Display Name Full Name Description	Values	Read-Write	Data Type
HOST GROUPS	Feedback	27	Fbk Mode Feedback Mode Selects the number of feedback devices and the type of discrepancy checking. "Single Fbk" (0) - 1 Encoder "Dual S/P Chk" (1) - 2 Encoders with Speed and Position Discrepancy Checking "Dual Spd Chk" (2) - 2 Encoders with Speed Discrepancy Checking "Dual Pos Chk" (3) - 2 Encoders with Position Discrepancy Checking	Default: 0 = "Single Fbk" Options: 0 = "Single Fbk" 1 = "Dual S/P Chk" 2 = "Dual Spd Chk" 3 = "Dual Pos Chk"	RW	Real
		28	Fbk 1 Type Feedback 1 Type Selects the type of feedback for encoder 1. When using the Safe Speed Monitor module with a 20-750-UFB-1 Universal Feedback module, set this parameter to 0 "Sine/Cosine" and ensure that the Universal Feedback module is set to a Sine/Cosine type device (P6 [FB0 Device Sel] and/or P36 [FB1 Device Sel]).	Default: 1 = "TTL" Options: 0 = "Sine/Cosine" 1 = "TTL" (Incremental)	RW	Real
		29	Fbk 1 Units Feedback 1 Units Selects rotary or linear feedback for encoder 1.	Default: 0 = "Rev" Options: 0 = "Rev" (Rotary) 1 = "mm" (Linear)	RW	Real
		30	Fbk 1 Polarity Feedback 1 Polarity Defines the direction polarity for encoder 1.	Default: 0 = "Normal" Options: 0 = "Normal" (Same as encoder) 1 = "Reversed"	RW	Real
		31	Fbk 1 Resolution Feedback 1 Resolution Counts/Revolution. 1...65,535 pulses/revolution or pulses/mm based on rotary or linear configuration defined by P29 [Fbk 1 Units].	Default: 1024 Min/Max: 1 / 65,535	RO	Real

File	Group	No.	Display Name Full Name Description	Values		Read-Write	Data Type
HOST GROUPS	Feedback	32	Fbk 1 Volt Mon Feedback 1 Voltage Monitor Encoder 1 voltage to be monitored.	Default: 0 = Voltage not monitored Options: 0 = Voltage not monitored 5 = 5V +/- 5% 9 = 7...12V 12 = 12V +/- 5% 24 = 24V - 10%...24V + 5%		RW	Real
		33	Fbk 1 Speed Feedback 1 Speed Displays the output speed of encoder 1. Units based on rotary or linear configuration defined by P29 [Fbk 1 Units].	Units: RPM mm/s Min/Max: -214,748,364.8 / 214,748,364.7 RPM -214,748,364.8 / 214,748,364.7mm/s		RO	Real
		34	Fbk 2 Units Feedback 2 Units Selects rotary or linear feedback for encoder 2.	Default: 0 = "Rev" Options: 0 = "Rev" (Rotary) 1 = "mm" (Linear)		RW	Real
		35	Fbk 2 Polarity Feedback 2 Polarity Defines the direction polarity for encoder 2.	Default: 0 = "Normal" Options: 0 = "Normal" (Same as encoder) 1 = "Reversed"		RW	Real
		36	Fbk 2 Resolution Feedback 2 Resolution Counts/Revolution. 0...65,535 pulses/revolution or pulses/mm based on rotary or linear configuration defined by P34 [Fbk 2 Units].	Default: 0 Min/Max: 1 / 65,535		RO	Real
		37	Fbk 2 Volt Mon Feedback 2 Voltage Monitor Encoder 2 voltage to be monitored.	Default: 0 = Voltage not monitored Options: 0 = Voltage not monitored 5 = 5V +/- 5% 9 = 7...12V 12 = 12V +/- 5% 24 = 24V - 10%...24V + 5%		RW	Real
		38	Fbk 2 Speed Feedback 2 Speed Displays the output speed of encoder 2. Units based on rotary or linear configuration defined by P34 [Fbk 2 Units].	Units: RPM mm/s Min/Max: -214,748,364.8 / 214,748,364.7 RPM -214,748,364.8 / 214,748,364.7mm/s		RO	Real
		39	Fbk Speed Ratio Feedback Speed Ratio Defines the ratio of the expected speed of encoder 2 divided by the expected speed of encoder 1. Ratio based on rotary or linear configuration defined by P29 [Fbk 1 Units].	Default: 0.0000 Min/Max: 0.0001 / 10,000.0		RW	Real
		40	Fbk Speed Tol Feedback Speed Tolerance Acceptable difference in speed between P33 [Fbk 1 Speed] and P38 [Fbk 2 Speed]. Units are based on rotary or linear configuration defined by P29 [Fbk 1 Units].	Units: RPM mm/s Min/Max: 0 / 6553.5 RPM 0 / 6553.5 mm/s		RW	Real
		41	Fbk Pos Tol Feedback Position Tolerance Acceptable difference in position between encoder 1 and encoder 2. Units are based on rotary or linear configuration defined by P29 [Fbk 1 Units].	Units: Deg mm Default: 0 Min/Max: 0 / 65,535 deg 0 / 65,535 mm		RW	Real

TIP Secondary feedback parameter settings are not required when P27 [Fbk Mode] is set to 0 "Single Fbk."

Notes:

Safe Stop and Safe Stop with Door Monitoring Modes

Introduction

This chapter describes the Safe Stop modes of safety operation and provides a list of configuration parameters as well as wiring examples for each Safe Stop mode.

Topic	Page
Safe Stop Mode	61
Safe Stop Parameter List	69
Safe Stop Wiring Example	71
Safe Stop with Door Monitoring Mode	72
Safe Stop with Door Monitoring Parameter List	73
Safe Stop with Door Monitoring Wiring Example	74

Safe Stop Mode

When properly configured for Safe Stop, the safety option monitors the Safe Stop input (SS_In) and initiates the configured Safe Stop Type upon deactivation of the input. The Safe Stop Type is configurable as either Safe Torque Off with or without Standstill Checking, Safe Stop 1, or Safe Stop 2. The safety option recognizes motion as stopped when encoder 1 feedback signals indicate the system has reached the configured Standstill Speed. Once Standstill Speed has been reached, the Door Control output (DC_Out) is set to Unlock.

In addition to setting the Standstill Speed, you configure both the Stop Delay P47 [Max Stop Time], the period during which deceleration occurs after a Safe Stop is initiated, and an optional Stop Monitoring Delay P46 [Stop Mon Delay], which is a delay between the action that requests the Safe Stop and the initiation of the configured Safe Stop Type. A P46 [Stop Mon Delay] can be configured only for Safe Stop 1 or Safe Stop 2.

When properly configured for Safe Stop mode, the safety option also monitors for faults and initiates the appropriate reaction. If the fault is a Safe State fault, the safety option enters the Safe State. If the fault is a Stop Category fault, the safety option initiates the configured Safe Stop Type.

Safe Stop Types

Use the P45 [Safe Stop Type] parameter to configure the type of stop that the system executes when a Safe Stop is initiated. A Safe Stop can be initiated by a transition of the SS_In input from ON to OFF or by the occurrence of a Stop Category fault.

While the safety option executes the configured Safe Stop Type, it continues to monitor the system. If a Stop Category fault is detected, the safety option sets the outputs to a faulted state, but allows for the door control logic to be set to Unlock if the feedback signals indicate Standstill Speed has been reached.

Safe Torque Off with Standstill Checking

This Safe Stop Type lets you access the hazard area immediately after motion is detected as stopped rather than waiting until a specific time has elapsed.

When Safe Torque Off with Standstill Checking is initiated, motion power is removed immediately and the configured Stop Delay P47 [Max Stop Time] begins. If the configured Standstill Speed is detected any time after the Safe Stop has been initiated and before the end of the configured Stop Delay, door control logic is set to Unlock.

If the Standstill Speed is not detected by the end of the configured Stop Delay, a Stop Speed fault occurs and the door control logic remains set to Lock until Standstill Speed is detected.

Figure 11 - Timing Diagram for Safe Torque-off with Standstill Checking

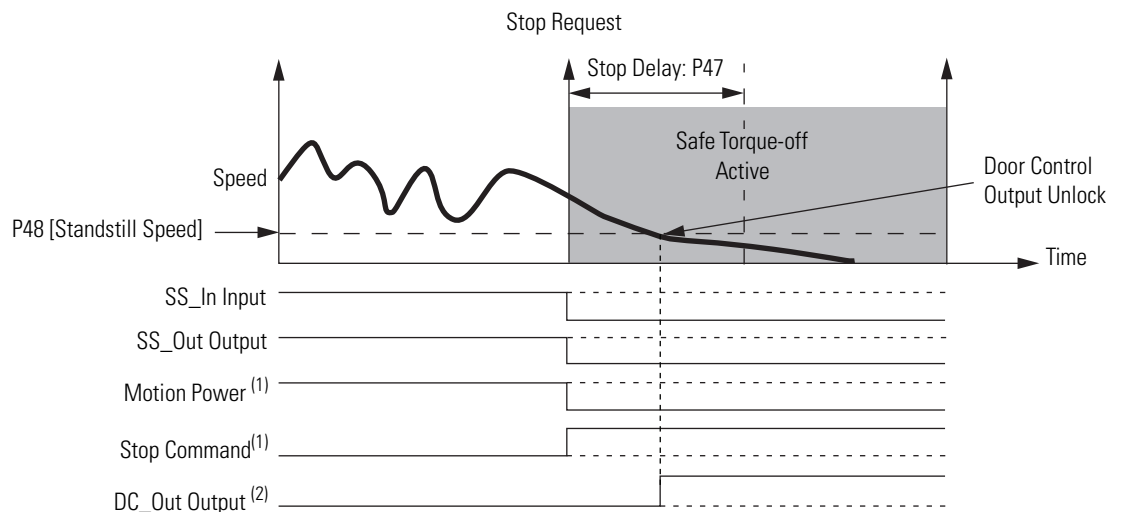

(1) This signal is internal, between the safety option and drive.

(2) DC_Out output shown configured as Power to Release. See Door Control on [page 67](#) for more information.

Safe Stop 1 and Safe Stop 2

When Safe Stop 1 or 2 is initiated by a transition of the SS_In input from ON to OFF, the safety option does not initiate the configured Stop Delay P47 [Max Stop Time] until after the optional Stop Monitoring Delay P46 [Stop Mon Delay] expires, unless a Stop Category fault occurs during the Stop Monitoring Delay.

When Safe Stop 1 or 2 is initiated by a Stop Category fault, the Stop Delay P47 [Max Stop Time] begins immediately, regardless of whether a Stop Monitoring Delay P46 [Stop Mon Delay] is configured.

Deceleration monitoring takes place during the Stop Delay P47 [Max Stop Time]. These three configurable parameters define the deceleration profile that is used:

- Deceleration Reference Speed, P50 [Decel Ref Speed]
- Deceleration Tolerance, P51 [Stop Decel Tol]
- Stop Delay, P47 [Max Stop Time]

If Standstill Speed is detected any time after the Safe Stop has been initiated and before the Stop Delay P47 [Max Stop Time] expires, door control logic is set to Unlock. If the Standstill Speed is not detected by the end of the configured Stop Delay P47 [Max Stop Time], a Stop Speed fault occurs. For Safe Stop 1, motion power is removed when Standstill Speed is reached. For Safe Stop 2, motion power is not removed.

Figure 12 - Timing Diagram for Safe Stop 1

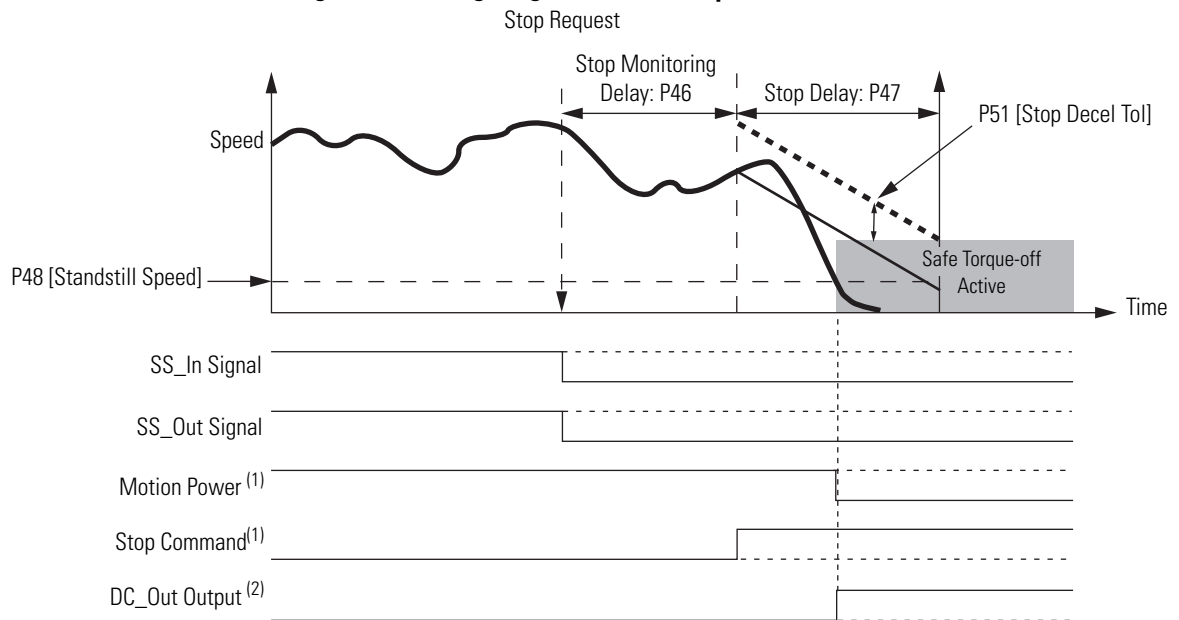

(1) This signal is internal, between the safety option and drive.

(2) DC_Out output shown configured as Power to Release. See Door Control on [page 67](#) for more information.

Figure 13 - Timing Diagram for Safe Stop 2

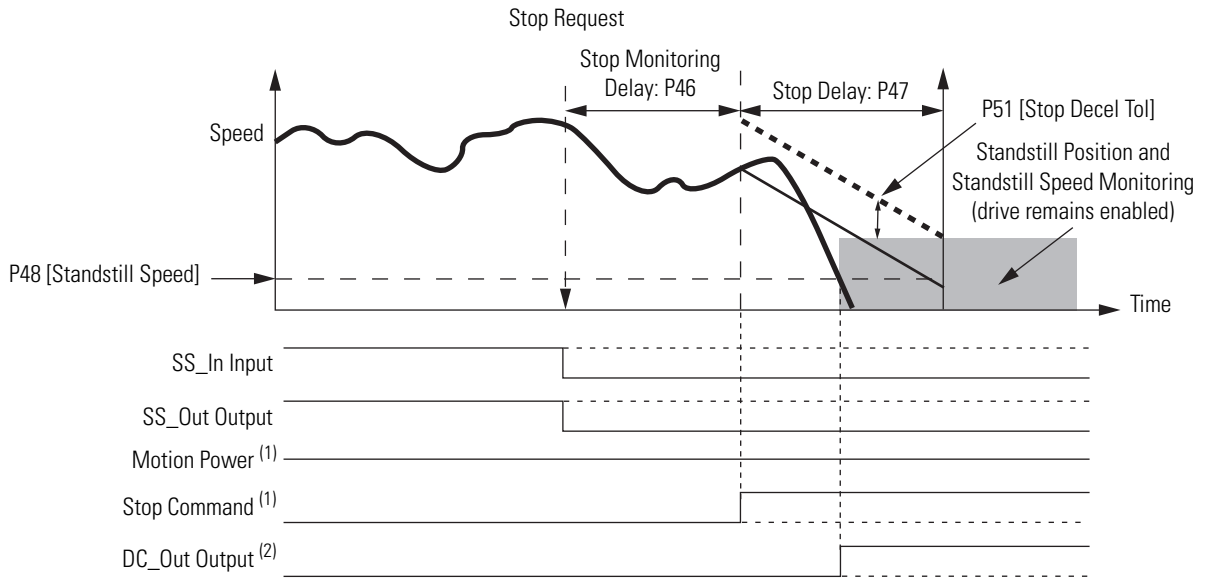

(1) This signal is internal, between the safety option and drive.
 (2) DC_Out output shown configured as Power to Release. See Door Control on [page 67](#) for more information.

Safe Torque Off without Standstill Checking

When Safe Torque Off without Standstill Checking is initiated, motion power is removed immediately and the configured Stop Delay P47 [Max Stop Time] begins. Door control logic is set to Unlock when the Stop Delay P47 [Max Stop Time] expires, regardless of speed.

Figure 14 - Timing Diagram for Safe Torque Off without Standstill Checking

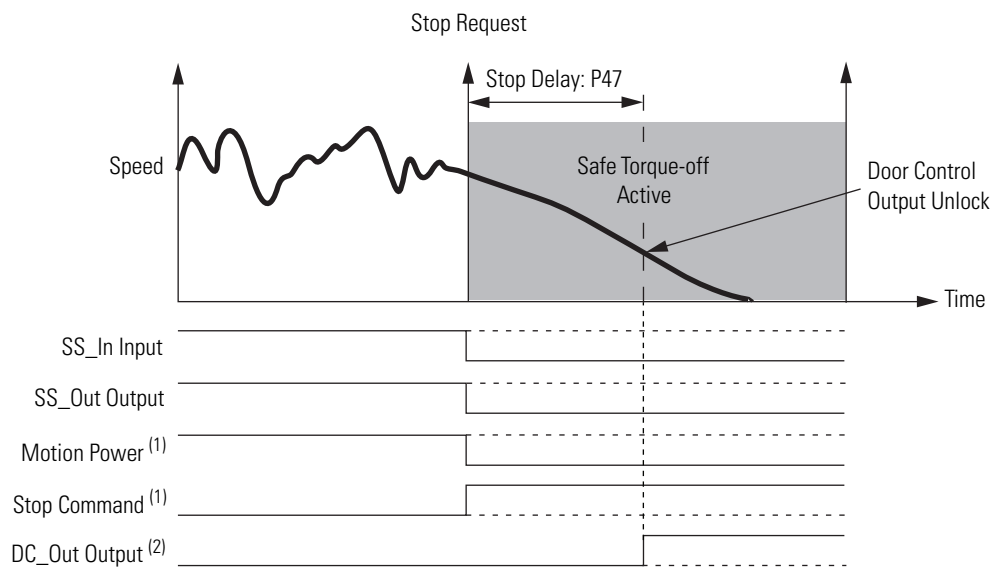

(1) This signal is internal, between the safety option and drive.
 (2) DC_Out output shown configured as Power to Release. See Door Control on [page 67](#) for more information.

TIP All Stop Types require an encoder to be connected.

Standstill Speed and Position Tolerance

For Safe Stop Types that include Standstill Checking, you set the Standstill Speed and Standstill Position Tolerance.

IMPORTANT The P48 [Standstill Speed] and P49 [Standstill Pos] parameters are not used for Safe Torque Off without Standstill Checking configurations. Set these parameters to zero.

Standstill Speed is used to declare motion as stopped. The system is at standstill when the speed detected is less than or equal to the configured Standstill Speed. The P48 [Standstill Speed] parameter defines the speed limit before the safety option determines standstill has been reached and the door control logic is set to Unlock.

IMPORTANT Standstill detection relies on the encoder 1 signal. The encoder 2 signal is used for fault diagnostics.

The P49 [Standstill Pos] parameter defines the position limit in encoder 1 units that is tolerated after standstill has been reached. If the position changes by more than the amount specified by the Standstill Position Tolerance, after standstill has been reached and the door is unlocked, a Motion After Stopped fault occurs. This type of fault results in the safety option entering the safe state.

The time required to verify that the Standstill Speed has been reached can be considerable when a very small Standstill Speed is configured and the encoder resolution of encoder 1 is very low.

- For rotary systems, the time (in seconds) will exceed $15 / [\text{Standstill Speed (RPM)} \times \text{Encoder 1 Resolution}]$.
- For linear systems, the time (in seconds) will exceed $0.25 / [\text{Standstill Speed (mm/s)} \times \text{Encoder 1 Resolution}]$.

Deceleration Monitoring

Deceleration monitoring takes place during the configured Stop Delay P47 [Max Stop Time], when the Safe Stop Type is configured as Safe Stop 1 or Safe Stop 2. The deceleration start speed is captured at the beginning of the Stop Delay P47 [Max Stop Time] and used to calculate the deceleration profile.

These parameters define the deceleration profile:

- Deceleration Reference Speed, P50 [Decel Ref Speed]
- Deceleration Tolerance, P51 [Stop Decel Tol]
- Stop Delay, P47 [Max Stop Time]

The Deceleration Reference Speed is relative to encoder 1. The P51 [Stop Decel Tol] parameter defines the percentage of the Deceleration Reference Speed that will be tolerated above the calculated deceleration profile.

Figure 15 - Deceleration Monitoring

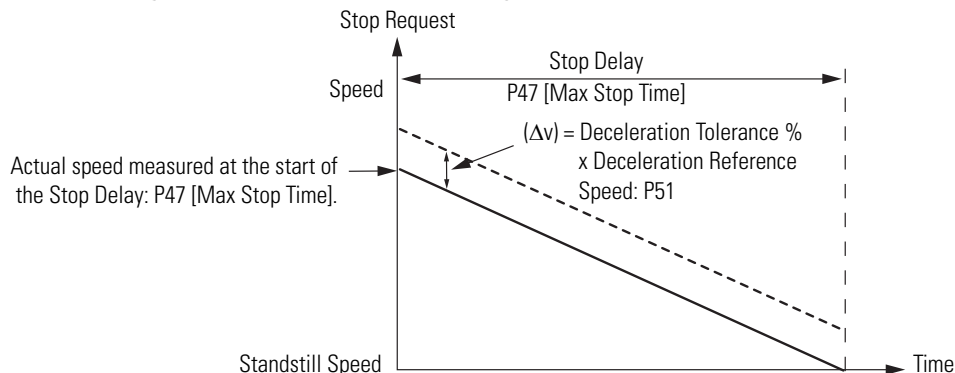

TIP To account for system overshoot and drive delay, choose Δv and set P50 [Decel Ref Speed] to the highest normal operating speed to calculate the Deceleration Tolerance. Remember that P51 [Stop Decel Tol] parameter is a percentage.

When deceleration monitoring is being performed, the speed limit monitored during the Stop Delay P47 [Max Stop Time] must be less than the Deceleration Monitoring Value or a Deceleration fault occurs. A Deceleration fault places outputs in the faulted state, but allows the door to be unlocked when the feedback signals indicate Standstill Speed has been reached.

Safe Stop Reset

The Safe Stop Reset (SS Reset) is a reset from the Safe State or from a stopping condition to actively monitoring motion. The reset is successful if the SS_In input is ON and no faults are present.



ATTENTION: For all types of reset (automatic, manual, or manual monitored), if a reset of the Safe Stop or Safe Limited Speed functions can result in machine operation, the other speed monitoring functions must be configured to detect and prevent dangerous motion.

When an SS Reset is requested, all diagnostic tests that can be performed prior to outputs being energized are performed prior to a successful SS Reset. If a diagnostic test can be performed only when outputs are energized, the test is performed immediately following the SS Reset.

IMPORTANT An SS Reset is not attempted if the Wait SS Cyc attribute is set (1), indicating that an error, other than an invalid configuration fault or ESM_In input fault, occurred.
The Wait SS Cyc attribute is bit 25 of the P68 [Guard Status] parameter.

Automatic

If the SS Reset is configured as automatic, the safety option always attempts a reset if it is in the Safe State or has initiated a Safe Stop Type. The reset is attempted when the SS_In input transitions from OFF to ON or if SS_In is ON at powerup.

Manual

If the SS Reset is configured as manual, the reset is attempted when the SS_In input is ON and the Reset_In input is ON.

Manual Monitored

A manual monitored reset requires an OFF to ON to OFF transition of the Reset_In input.



If at any time before the closing and opening of the Reset_In input, the SS_In input transitions from ON to OFF, the reset is aborted.

Faults

If a fault occurs, other than an Invalid Configuration fault or an ESM Monitoring fault, the SS_In input must turn OFF and ON again to reset the Wait SS Cyc bit before a successful SS Reset can occur.

Door Control

The status of door control logic (Lock or Unlock) and the Door Monitor Input (DM_In), along with the safety option's location in the system P20 [Cascaded Config] and Door Control Output Type P57 [Door Out Type] determine whether the Door Control output (DC_Out) is locked or unlocked during normal operation.

When the DC_Out output has no faults, the safety option is configured for Safe Stop, and the safety option is monitoring motion, the door control logic state is Locked. It remains locked while a Safe Stop is being executed. For all Safe Stop Types except Safe Torque Off without Standstill Checking, door control logic is set to Unlock only when Standstill Speed has been reached.



ATTENTION: If the Safe Stop Type is Safe Torque Off without Standstill Checking, door control logic is set to Unlock when the Stop Delay P47 [Max Stop Time] has elapsed, regardless of speed.

Configuration

You configure the type of door control for each Safe Speed Monitor Option module in the system.

P57 [Door Out Type] Settings		DC_Out Status and Lock State
Single and Last Units	First and Middle Units	
0 = Power to Release	Not valid	ON = Door is unlocked. OFF = Door is locked.
1 = Power to Lock	Not valid	ON = Door is locked. OFF = Door is unlocked.
2 = Cascading (2 Ch Sourcing)	2 = Cascading (2 Ch Sourcing)	ON = Door is unlocked. OFF = Door is locked.

A single or last safety option in a cascaded system can be configured for any Door Output Type setting. For example, choose 2 Ch Sourcing to connect to a safety programmable controller input. The first or middle safety option in a cascaded system must be configured as 2 Ch Sourcing.



ATTENTION: When the DC_Out output is configured as Power to Lock (P57 [Door Out Type] = 1), the safe state and faulted state is Unlocked. Make sure that this possibility does not create a hazard.

IMPORTANT

When the DC_Out output is configured for no pulse testing (P74 [Door Out Mode] = 1) and the P57 [Door Out Type] setting is Power to Lock, and a reset is attempted, the DC_Out output is pulsed low for 12 ms. During the 12 ms, the door is unlocked.

Effect of Faults

These fault conditions, which affect the integrity of the DC_Out output, will force the DC_Out output to its safe state (OFF) regardless of the status of door control logic:

- DC Out fault
- Invalid Configuration fault
- Internal Power Supply or MPU faults



ATTENTION: If a fault occurs after Standstill Speed has been reached, door control remains unlocked.

For fault conditions where the DC_Out output can maintain its integrity, both door control logic and the DC_Out output hold last state. If hold last state cannot be maintained, faults may turn the DC_Out output OFF.

Lock Monitoring

If Lock Monitoring is enabled, the Lock Monitoring input (LM_In) must be in the ON state any time the Door Control output (DC_Out) is in the Lock state, except for the 5 seconds following the DC_Out output's transition from the Unlocked state to the Locked state. If the LM_In input is not ON during this time, a Lock Monitoring fault occurs. The LM_In input must be OFF when the DM_In input transitions from ON to OFF (the door opens).

A Lock Monitoring fault is a Stop Category fault, which initiates the configured Safe Stop Type.

Safe Stop Parameter List

To configure the safety option for Safe Stop mode, set these parameters in addition to the General and Feedback parameters listed on [page 53](#) and [page 58](#).

File	Group	No.	Display Name Full Name Description	Values		Read-Write	Data Type
HOST GROUPS	General	21	Safety Mode Safety Mode Defines the primary operating mode of the speed monitoring safety functions.	Setting:	1 = "Safe Stop"	RW	Real
		44	Safe Stop Input Safe Stop Input Configuration for Safe Stop input (SS_In). "2NC" (1) – Dual-channel equivalent "2NC 3s" (2) – Dual-channel equivalent 3 s "1NC+1NO" (3) – Dual-channel complementary "1NC+1NO 3s" (4) – Dual-channel complementary 3 s "2 OSSD 3s" (5) – Dual-channel SS equivalent 3 s "1NC" (6) – Single channel equivalent	Default: Options:	1 = "2NC" 0 = "Not used" 1 = "2NC" 2 = "2NC 3s" 3 = "1NC+1NO" 4 = "1NC+1NO 3s" 5 = "2 OSSD 3s" 6 = "1NC"	RW	Real
	Stop	45	Safe Stop Type Safe Stop Type Safe operating stop type selection. This defines the type of Safe Stop that is performed if the Safe Stop function is initiated by a stop type condition. "Torque Off" (0) – Safe Torque Off With Standstill Checking "Torque Off NoCk" (3) – Safe Torque Off Without Standstill Checking	Default: Options:	0 = "Torque Off" 0 = "Torque Off" 1 = "Safe Stop 1" 2 = "Safe Stop 2" 3 = "Torque Off NoCk"	RW	Real
		46	Stop Mon Delay Stop Monitoring Delay Defines the monitoring delay between the request and the Max Stop Time when the request for a Safe Stop 1 or a Safe Stop 2 is initiated by an SS_In input ON to OFF transition. If the Safe Stop Type is Safe Torque Off With or Without Standstill Speed Checking, the Stop Monitor Delay must be 0 or a Invalid Configuration Fault occurs.	Units: Default: Min/Max:	Secs 0 0 / 6553.5	RW	Real
		47	Max Stop Time Maximum Stop Time Defines the maximum stop delay time that is used when the Safe Stop function is initiated by a stop type condition.	Units: Default: Min/Max:	Secs 0 0 / 6553.5	RW	Real
		48	Standstill Speed Standstill Speed Defines the speed limit that is used to declare motion as stopped. Units are based on rotary or linear configuration defined by P29 [Fbk 1 Units]. Not valid for Safe Torque Off without Standstill Checking.	Units: Default: Min/Max:	RPM mm/s 0.001 0.001 / 65.535 RPM 000 / 65.535 mm/s	RW	Real

File	Group	No.	Display Name Full Name Description	Values		Read-Write	Data Type
HOST GROUPS	Stop	49	Standstill Pos Standstill Position Defines the position limit window in encoder 1 degrees or mm that will be tolerated after a safe stop condition has been detected. Degrees (360° = 1 revolution) or mm based on rotary or linear configuration defined by P29 [Fbk 1 Units]. Not valid for Safe Torque Off without Standstill Checking.	Units: Default: Min/Max:	Deg mm 10 0 / 65,535 deg 0 / 65.535 mm	RW	Real
		50	Decel Ref Speed Deceleration Reference Speed Determines deceleration rate to monitor for Safe Stop 1 or Safe Stop 2. Units are based on rotary or linear configuration defined by encoder 1 feedback configuration, P29 [Fbk 1 Units].	Units: Default: Min/Max:	RPM mm/s 0 0 / 65,535 RPM 0 / 65,535 mm/s	RW	Real
		51	Stop Decel Tol Stop Deceleration Tolerance This is the acceptable tolerance above the deceleration rate set by the Decel Ref Speed parameter.	Units: Default: Min/Max:	% 0 0 / 100	RW	Real
	Door Control	57	Door Out Type Door Output Type Defines the lock and unlock state for door control output (DC_Out). When Door Out Type equals power to release, DC_Out is OFF in the lock state and ON in the unlock state. When Door Out Type equals power to lock, DC_Out is ON in the lock state and OFF in the unlock state. The first and middle units of a multi-axis system must be configured as cascading (2).	Default: Options:	0 = "Pwr to Rel" 0 = "Pwr to Rel" 1 = "Pwr to Lock" 2 = "2 Ch Sourcing"	RW	Real
		59	Lock Mon Enable Lock Monitor Enable Lock Monitoring can only be enabled when the speed monitoring safety option is a single unit or as the first unit in a multi-axis system (P20 [Cascaded Config] = 0 or 1).	Default: Options:	0 = "Disable" 0 = "Disable" 1 = "Enable"	RW	Real
		60	Lock Mon Input Lock Monitor Input Configuration for the Lock Monitor input (LM_In). "2NC" (1) – Dual-channel equivalent "2NC 3s" (2) – Dual-channel equivalent 3 s "1NC+1NO" (3) – Dual-channel complementary "1NC+1NO 3s" (4) – Dual-channel complementary 3 s "2 OSSD 3s" (5) – Dual-channel SS equivalent "1NC" (6) – Single channel equivalent	Default: Options:	0 = "Not used" 0 = "Not used" 1 = "2NC" 2 = "2NC 3s" 3 = "1NC+1NO" 4 = "1NC+1NO 3s" 5 = "2 OSSD 3s" 6 = "1NC"	RW	Real
		72	SS Out Mode Defines whether the SS_Out output is pulse-tested. ⁽¹⁾ If pulse-testing is turned off for any output, the SIL, Category, and PL rating is reduced for the entire safety system.	Default: Options:	0 = "Pulse test" 0 = "Pulse test" 1 = "No pulse test"	RW	Real

(1) If pulse-testing is turned off for any output, the SIL, Category, and PL rating is reduced for the entire safety system.

Safe Stop Wiring Example

This example illustrates safe stop wiring.

Figure 16 - Master, Safe Stop (First or Single Unit)

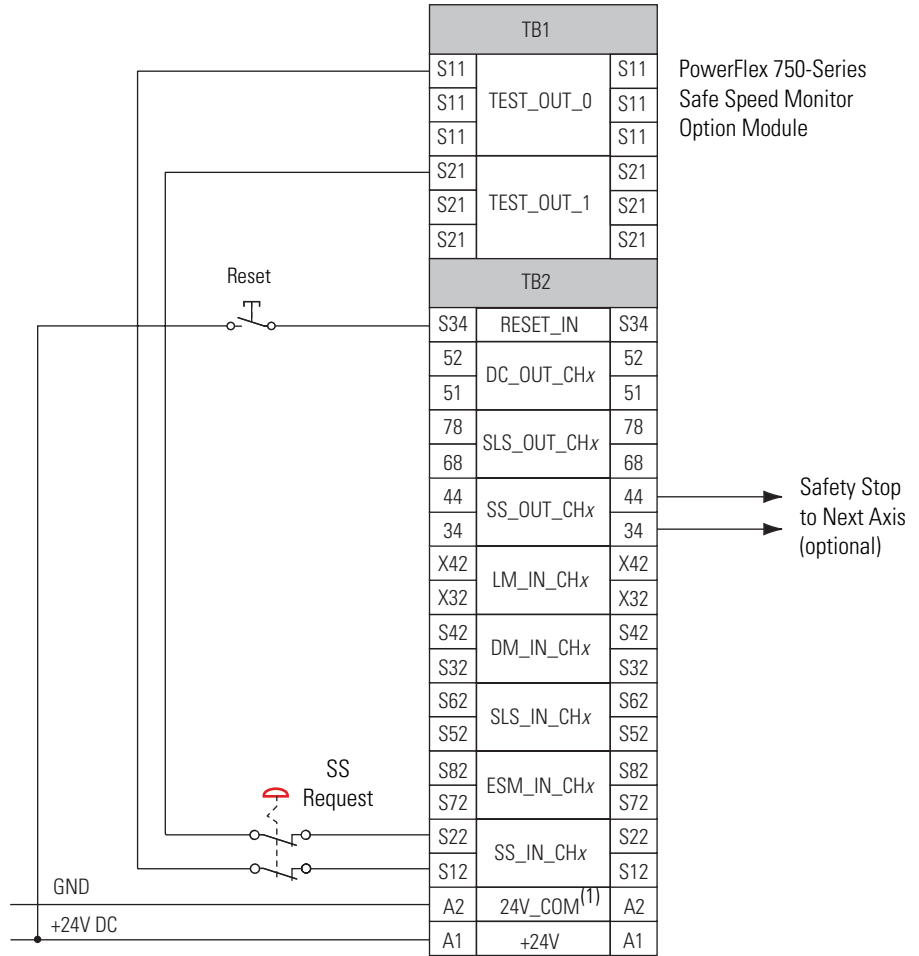

(1) 24V_Com must be at the same potential as the drive common because of the encoder signal.

Safe Stop with Door Monitoring Mode

When properly configured for Safe Stop with Door Monitoring, the safety option monitors the Safe Stop input (SS_In) and initiates the configured Safe Stop Type upon deactivation of the input as described in Safe Stop Mode on [page 61](#).

In addition, the safety option verifies through monitoring the Door Monitor input (DM_In) that the door interlock solenoid controlled by the Door Control output (DC_Out) is in an expected state. The DM_In input is ON when the door is closed and OFF when the door is open. If the door is monitored as opened during Safe Stop monitoring, a Door Monitoring fault occurs and the safety option initiates the configured Safe Stop Type.

You can monitor the door's status with or without using the Door Control (lock/unlock) function. When door control logic is set to Lock, the safety option puts the solenoid into the locked state when the machine is not at a safe speed or at Standstill Speed.

Lock Monitoring

If a Safety mode that includes Door Monitoring is selected and Lock Monitoring is enabled, the Lock Monitor input (LM_In) signal must be OFF any time that the Door Monitor input (DM_In) transitions from ON to OFF.

IMPORTANT If your application uses Lock Monitoring without Door Monitoring, you must use some means to make sure that the Lock Monitor is not stuck at Lock indication.

SS Reset

If the Door Monitor input (DM_In) is OFF when a Safe Stop (SS) Reset is attempted in any state other than actively monitoring Safe Limited Speed, a Door Monitoring fault occurs and the safety option initiates the configured Safe Stop Type.

Safe Stop with Door Monitoring Parameter List

To configure the safety option for Safe Stop with Door Monitoring, set the DM Input parameter in addition to the Safe Stop parameters listed on page 69.

File	Group	No.	Display Name Full Name Description	Values	Read-Write	Data Type
HOST GROUPS	General	21	Safety Mode Safety Mode Defines the primary operating mode of the speed monitoring safety functions.	Setting: 2 = "Safe Stop DM"	RW	Real
	Door Control	58	DM Input Door Monitor Input Configuration for the Door Monitor input (DM_In). "2NC" (1) – Dual-channel equivalent "2NC 3s" (2) – Dual-channel equivalent 3 s "1NC+1NO" (3) – Dual-channel complementary "1NC+1NO 3s" (4) – Dual-channel complementary 3 s "2 OSSD 3s" (5) – Dual-channel SS equivalent 3 s "1NC" (6) – Single channel equivalent	Default: 0 = "Not used" ⁽¹⁾ Options: 0 = "Not used" 1 = "2NC" 2 = "2NC 3s" 3 = "1NC+1NO" 4 = "1NC+1NO 3s" 5 = "2 OSSD 3s" 6 = "1NC"	RW	Real

(1) You must configure this parameter with a non-zero value in this mode.

Safe Stop with Door Monitoring Wiring Example

This example illustrates wiring for safe stop with door monitoring.

Figure 17 - Master, Safe Stop with Door Monitoring (First or Single Unit)

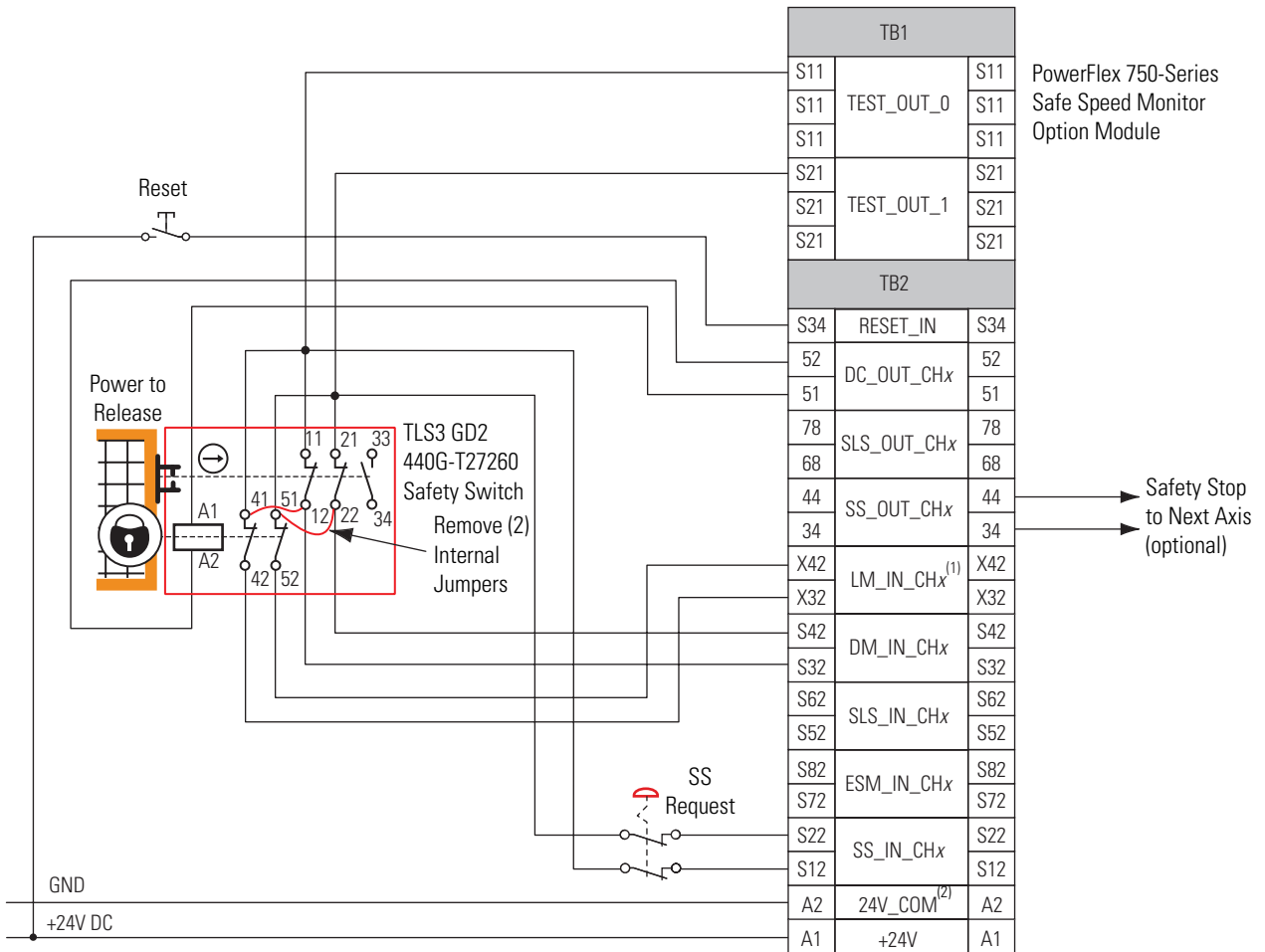

(1) Lock monitoring connections are not required for Safe Limited Speed with Door Monitoring mode operation.
 (2) 24V_Com must be at the same potential as the drive common because of the encoder signal.

Introduction

Safe Limited Speed (SLS) Modes

This chapter describes the Safe Limited Speed (SLS) modes of safety operation and provides a list of configuration parameters along with wiring examples for each mode.

Topic	Page
Safe Limited Speed (SLS) Mode	75
Safe Limited Speed Parameter List	78
Safe Limited Speed Wiring Example	80
Safe Limited Speed with Door Monitoring Mode	81
SLS with Door Monitoring Parameter List	82
SLS with Door Monitoring Wiring Example	83
Safe Limited Speed with Enabling Switch Monitoring Mode	83
SLS with Enabling Switch Monitoring Parameter List	84
SLS with Enabling Switch Monitoring Wiring Example	85
Safe Limited Speed with Door Monitoring and Enabling Switch Monitoring Mode	86
SLS with Door Monitoring and Enabling Switch Monitoring Parameter List	89
SLS with Door Monitoring and Enabling Switch Monitoring Wiring Example	90
Safe Limited Speed Status Only Mode	91
SLS Status Only Parameter List	93
SLS Status Only Wiring Examples	94

Safe Limited Speed (SLS) Mode

When properly configured for Safe Limited Speed, the safety option performs Safe Limited Speed (SLS) monitoring functions in addition to the Safe Stop function described in Safe Stop Mode on [page 61](#). When the Safe Limited Speed input (SLS_In) is OFF, feedback velocity is monitored and compared against a configurable Safe Speed Limit.

If the feedback velocity is below the Safe Speed Limit during Safe Limited Speed monitoring, the Door Control output (DC_Out) is unlocked after the P53 [LimSpd Mon Delay], if configured, has expired.



ATTENTION: Make sure that an unlocked door does not result in a hazardous situation.

If a Safe Stop Type is initiated or a fault occurs while the safety option is actively monitoring Safe Limited Speed, door control remains unlocked. The safe state of the SLS_In input may allow the door be unlocked.

If the measured velocity exceeds the Safe Speed Limit, an SLS fault occurs and the configured P45 [Safe Stop Type] is initiated. An optional P53 [LimSpd Mon Delay] can be configured to delay the start of Safe Limited Speed monitoring.

Safe Limited Speed monitoring is requested by a transition of the Safe Limited Speed input (SLS_In) from ON to OFF. When the SLS_In input is ON, the safety option does not monitor for Safe Limited Speed and the measured velocity can be above or below the Safe Speed Limit.



ATTENTION: If the Reset Type is configured as Automatic, Safe Limited Speed monitoring is disabled when the SLS_In input is turned ON and the machine operates at its normal run speed. Make sure that the SLS_In input cannot transition to ON while someone is in the hazardous area.

If you configure a P53 [LimSpd Mon Delay], the delay begins when Safe Limited Speed monitoring is requested by the SLS_In transition from ON to OFF. The safety option begins monitoring for Safe Limited Speed when the delay times out. If system speed is greater than or equal to the configured Safe Speed Limit during Safe Limited Speed monitoring, an SLS fault occurs and the safety option initiates the configured Safe Stop Type.

Figure 18 - Timing Diagram for Safe Limited Speed (SLS)

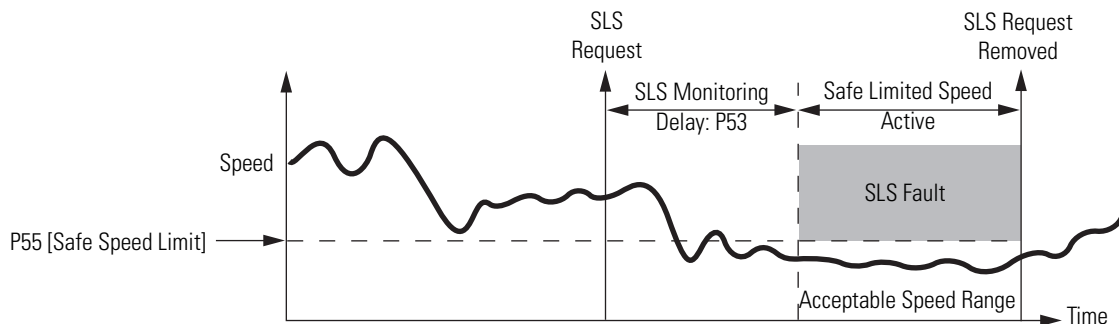

Safe Limited Speed Reset

A Safe Limited Speed (SLS) Reset is a transition out of actively monitoring safe limited speed. It can also occur during a P53 [LimSpd Mon Delay], if one is configured. When an SLS Reset occurs, the safety option no longer monitors for safe limited speed and the door is locked. Speed is no longer restricted to the configured Safe Speed Limit.

The SLS Reset function monitors the SLS_In input. If an SLS Reset is requested, the safety option checks that no faults are present and verifies that the SLS_In input is ON (closed circuit) before the reset is performed.

When the input is OFF, Safe Limited Speed monitoring takes place, after the P53 [LimSpd Mon Delay], if one is configured. An SLS Reset can be requested during active Safe Limited Speed monitoring or during a Safe Limited Speed Monitoring Delay. If a reset is requested during a Safe Limited Speed Monitoring Delay, the reset does not wait for the delay to time out.

Automatic

Once the SLS_In input is ON (closed), the safety option lets the drive resume normal operating speed. No reset button is required to re-enter the normal run state.

Manual

When the SLS_In input transitions from OFF to ON and the Reset_In input is ON, an SLS_Reset is attempted.

If the SLS_In transitions from OFF to ON and the Reset_In input is OFF, the safety option stays in its current state, whether it is actively monitoring Safe Limited Speed or is in a Safe Limited Speed Monitoring Delay, and waits for the Reset_In input to transition to ON, before attempting the SLS_Reset. If at any time, the SLS_In input transitions back to OFF, the SLS_Reset is aborted.

Manual Monitored

When the SLS_In input transitions from OFF to ON, the safety option waits for an OFF to ON to OFF transition of the Reset_In input before an SLS_Reset is attempted. If at any time during this period, the SLS_In input transitions back to OFF, the SLS_Reset is aborted.

Safe Limited Speed Parameter List

To configure the safety option for Safe Limited Speed monitoring, set these parameters in addition to the Safe Stop parameters listed beginning on [page 69](#).

File	Group	No.	Display Name Full Name Description	Values		Read-Write	Data Type
HOST GROUPS	General	21	Safety Mode Safety Mode Defines the primary operating mode of the speed monitoring safety functions.	Setting:	3 = "Lim Speed"	RW	Real
		52	Lim Speed Input Limited Speed Input Configuration for Safe Limited Speed input (SLS_In). "2NC" (1) – Dual-channel equivalent "2NC 3s" (2) – Dual-channel equivalent 3 s "1NC+1NO" (3) – Dual-channel complementary "1NC+1NO 3s" (4) – Dual-channel complementary 3 s "2 OSSD 3s" (5) – Dual-channel SS equivalent 3 s "1NC" (6) – Single channel equivalent	Default: Options:	0 = "Not used" ⁽²⁾ 0 = "Not used" 1 = "2NC" 2 = "2NC 3s" 3 = "1NC+1NO" 4 = "1NC+1NO 3s" 5 = "2 OSSD 3s" 6 = "1NC"	RW	Real
	Limited Speed	53	LimSpd Mon Delay Limited Speed Monitoring Delay Defines the Safe Limited Speed Monitoring Delay between the SLS_In ON to OFF transition and the initiation of the Safe Limited Speed (SLS) or Safe Maximum Speed (SMS) monitoring.	Units: Default: Min/Max:	Secs 0 0 / 6553.5	RW	Real
		55	Safe Speed Limit Safe Speed Limit Defines the speed limit that will be monitored in Safe Limited Speed (SLS) mode. Units are based on rotary or linear configuration defined by P29 [Fbk 1 Units].	Units: Default: Min/Max:	RPM mm/s 0 0 / 6553.5 RPM 0 / 6553.5 mm/s	RW	Real
		73	SLS Out Mode Defines whether the SLS_Out output is pulse-tested. ⁽¹⁾ If pulse-testing is turned off for any output, the SIL, Category, and PL rating is reduced for the entire safety system.	Default: Options:	0 = "Pulse test" 0 = "Pulse test" 1 = "No pulse test"	RW	Real

(1) If pulse-testing is turned off for any output, the SIL, Category, and PL rating is reduced for the entire safety system.
 (2) You must configure this parameter with a non-zero value in this mode.

Configuring the PowerFlex 750-Series Drive for SLS Operation

The safety option commands the drive to enter Manual Mode during Safe Limited Speed monitoring.

IMPORTANT The drive parameters listed below must be configured for the drive to accept this command.

P326 [Manual Cmd Mask] - Turn **off** the bit corresponding to the safety option's port to allow modules installed in other ports to continue to control the drive when it is operating in Manual Mode. For example, if the safety option is installed in port 6, then turn off bit 6 in this parameter.

Refer to [Install the PowerFlex Safety Option Module](#) on page [31](#) to review the location of ports used by the safety option.

P327 [Manual Ref Mask] - Turn **on** the bit corresponding to the safety option's port to allow the safety option to command the drive to use its Manual Speed Reference when it is operating in Manual Mode. For example, if the safety option is installed in port 6, then turn on bit 6 in this parameter.

P328 [Alt Man Ref Sel] - Set this parameter to select the desired speed reference when the drive is operating in Manual Mode. For example, set this parameter to the value Port 0: Preset Speed 1 to configure the drive to use its P571 [Preset Speed 1] parameter as the Manual Speed Reference. In this case, the drive's P571 [Preset Speed 1] parameter must be less than the P55 [Safe Speed Limit] parameter in the safety option to avoid causing an SLS Speed Fault.

When a Safe Limited Speed Reset occurs, the safety option commands the drive to exit Manual Mode and the drive will resume operation using the speed reference that was selected prior to Safe Limited Speed monitoring.

Safe Limited Speed Wiring Example

This example illustrates wiring for safe limited speed.

Figure 19 - Master, Safe Limited Speed (First or Single Unit)

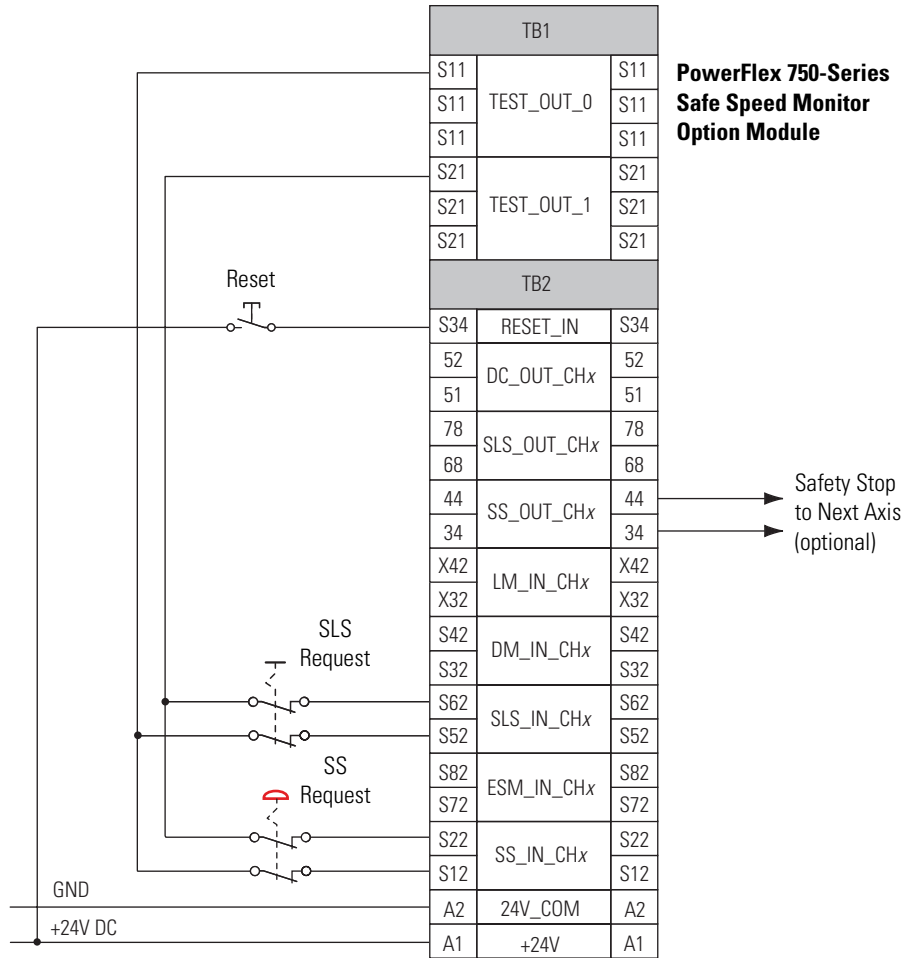

Safe Limited Speed with Door Monitoring Mode

When properly configured for Safe Limited Speed with Door Monitoring, the safety option performs Safe Limited Speed (SLS) monitoring functions as described in Safe Limited Speed (SLS) Mode on [page 75](#) in addition to the Safe Stop functions as described in Safe Stop Mode on [page 61](#).

In addition, the safety option verifies through monitoring the Door Monitor input (DM_In) that the safety option controlled by the Door Control output (DC_Out) is in the expected state. If the door is monitored as opened when it should be closed, the safety option initiates the configured Safe Stop Type.

The Door Monitor input (DM_In) is ON when the door is closed and OFF when the door is open. The DM_In input must be ON (door closed) whenever Safe Limited Speed monitoring is inactive (SLS_In is ON, meaning the circuit is closed). The DM_In input must also be ON (door closed) during a Safe Limited Speed Monitoring Delay [LimSpd Mon Delay]. A Door Monitor fault is a Stop Category fault, which initiates the configured Safe Stop Type.

If Safe Limited Speed Monitoring is active (SLS_In input is OFF) and the safety option has verified a safe speed condition, the door can be unlocked and opened.



ATTENTION: Make sure that an open door does not result in a hazardous situation.

If a Safe Stop Type is initiated or a fault occurs while the safety option is actively monitoring Safe Limited Speed, door control remains unlocked. The safe state of the SLS_In input may allow the door to be unlocked.

You can monitor the door's status with or without the door control (lock/unlock) function. When door control logic is set to lock, it prevents personnel from entering the hazardous area when the machine is not at a safe speed or at Standstill Speed.

Figure 20 - Timing Diagram for Safe Limited Speed (SLS) with Door Monitoring Mode

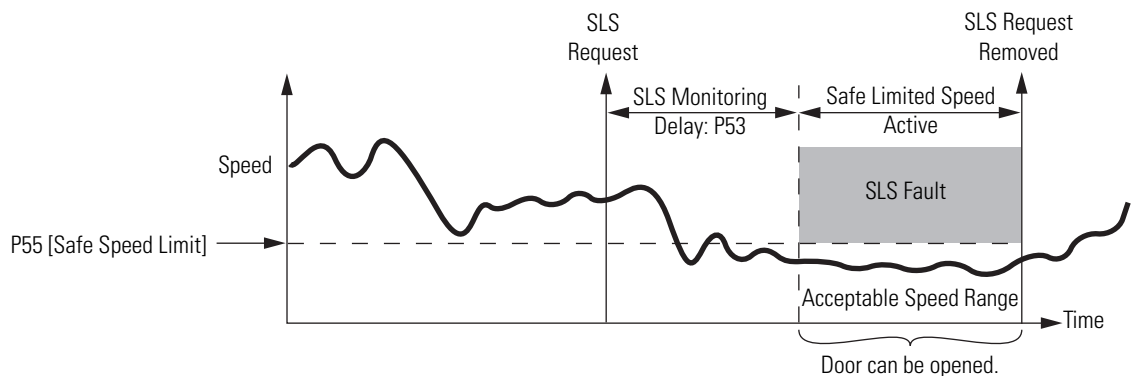

Safe Limited Speed Reset

When properly configured for Safe Limited Speed with Door Monitoring, the safety option must be monitoring motion (SLS_In input is OFF) if the door is open (DM_In is OFF). Make sure the door is closed before requesting an SLS Reset.

A Safe Limited Speed Reset results in a Door Monitoring fault if the door is open (DM_In is OFF) when the reset is requested by a transition of the SLS_In input from OFF to ON. A Door Monitor fault is a Stop Category fault, which initiates the configured Safe Stop Type.

SLS with Door Monitoring Parameter List

To configure the safety option for Safe Limited Speed with Door Monitoring, set the DM Input parameter in addition to the Safe Stop parameters listed on [page 69](#) and the Safe Limited Speed parameters listed on [page 78](#).

File	Group	No.	Display Name Full Name Description	Values		Read-Write	Data Type
HOST GROUPS	General	21	Safety Mode Safety Mode Defines the primary operating mode of the speed monitoring safety functions.	Setting:	4 = "Lim Speed DM"	RW	Real
	Door Control	58	DM Input Door Monitor Input Configuration for the Door Monitor input (DM_In). "2NC" (1) – Dual-channel equivalent "2NC 3s" (2) – Dual-channel equivalent 3 s "1NC+1NO" (3) – Dual-channel complementary "1NC+1NO 3s" (4) – Dual-channel complementary 3 s "2 OSSD 3s" (5) – Dual-channel SS equivalent 3 s "1NC" (6) – Single channel equivalent	Default: Options:	0 = "Not used" ⁽¹⁾ 0 = "Not used" 1 = "2NC" 2 = "2NC 3s" 3 = "1NC+1NO" 4 = "1NC+1NO 3s" 5 = "2 OSSD 3s" 6 = "1NC"	RW	Real

(1) You must configure this parameter with a non-zero value in this mode.

SLS with Door Monitoring Wiring Example

This example illustrates wiring for SLS with door monitoring.

Figure 21 - Master, Safe Limited Speed with Door Monitoring (First or Single Unit)

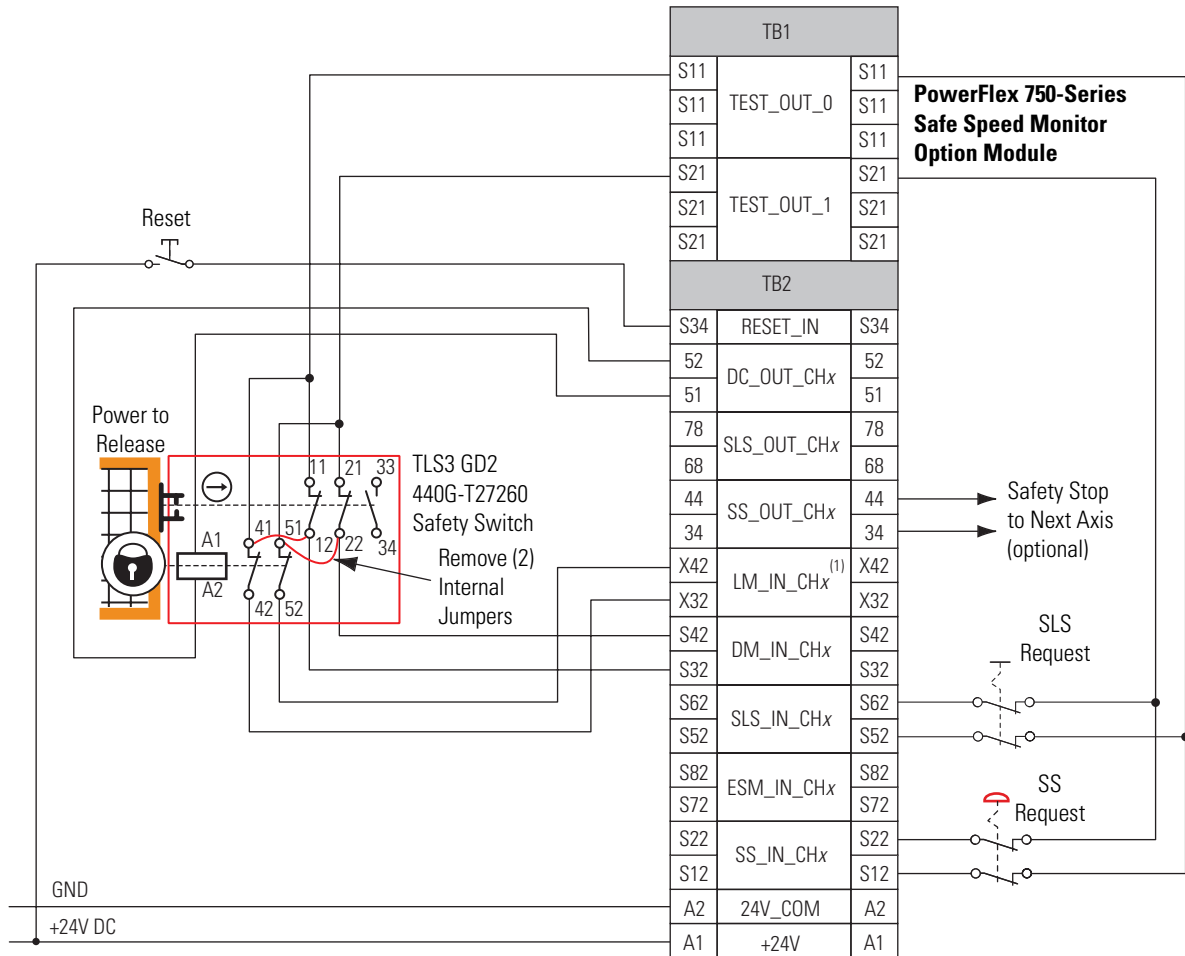

(1) Lock monitoring connections are not required for Safe Limited Speed with Door Monitoring mode operation.

Safe Limited Speed with Enabling Switch Monitoring Mode

When properly configured for Safe Limited Speed with Enabling Switch Monitoring, the safety option performs Safe Limited Speed (SLS) monitoring functions as described in Safe Limited Speed (SLS) Mode on [page 75](#) in addition to the Safe Stop functions as described in Safe Stop Mode on [page 61](#).

In addition, the safety option monitors the Enabling Switch Monitor input (ESM_In) after the Safe Limited Speed Monitoring Delay [LimSpd Mon Delay] times out. Once the enabling switch is activated, the ESM_In input must remain ON while Safe Limited Speed monitoring is active or an ESM Monitoring fault occurs. An ESM Monitoring fault is a Stop Category fault, which initiates the configured Safe Stop Type.

IMPORTANT When Safe Limited Speed Monitoring is inactive, the ESM_In input is not monitored.

Safe Stop Reset (SS Reset) and Safe Limited Speed Reset (SLS Reset)

If an ESM Monitoring Fault occurs due to the ESM_In input turning OFF (enabling switch is released), the safety option can be reset without cycling the SS_In input. To perform an SLS Reset, first return the ESM_In input to ON (grip the enabling switch in the middle position). Then, press and release the reset button. This is the only case where the SS_In input does not need to be cycled to reset the safety option following a fault.

While Safe Limited Speed is being monitored after the P53 [LimSpd Mon Delay] times out, if the SLS_In input is ON and an SLS Reset occurs, the ESM_In is not monitored.



ATTENTION: Make sure that the SLS_In input cannot transition to ON while someone is in the hazard area.

Use appropriate procedures when selecting safe limited speed to prevent other users from changing the mode while personnel are in the machine area.

If you attempt an SS Reset when the SLS_In input is OFF and the ESM_In input is OFF, an ESM Monitoring fault occurs. An ESM Monitoring fault is a Stop Category fault, which initiates the configured Safe Stop Type.

SLS with Enabling Switch Monitoring Parameter List

To configure the safety option for Safe Limited Speed with Enabling Switch Monitoring, set the P54 [Enable SW Input] parameter in addition to the Safe Stop parameters listed on [page 69](#) and the Safe Limited Speed parameters listed on [page 78](#).

File	Group	No.	Display Name Full Name Description	Values		Read-Write	Data Type
HOST GROUPS	General	21	Safety Mode Safety Mode Defines the primary operating mode of the speed monitoring safety functions.	Setting:	5 = "Lim Speed ES"	RW	Real
	Limited Speed	54	Enable SW Input Enable Switch Input Configuration for the Enabling Switch input (ESM_In). "2NC" (1) – Dual-channel equivalent "2NC 3s" (2) – Dual-channel equivalent 3 s "1NC+1NO" (3) – Dual-channel complementary "1NC+1NO 3s" (4) – Dual-channel complementary 3 s "2 OSSD 3s" (5) – Dual-channel SS equivalent 3 s "1NC" (6) – Single channel equivalent	Default: Options:	0 = "Not used" ⁽¹⁾ 0 = "Not used" 1 = "2NC" 2 = "2NC 3s" 3 = "1NC+1NO" 4 = "1NC+1NO 3s" 5 = "2 OSSD 3s" 6 = "1NC"	RW	Real

(1) You must configure this parameter with a non-zero value in this mode.

SLS with Enabling Switch Monitoring Wiring Example

This example illustrates wiring for SLS with enabling switch monitoring.

Figure 22 - Master, Safe Limited Speed with Enabling Switch Monitoring (First or Single Unit)

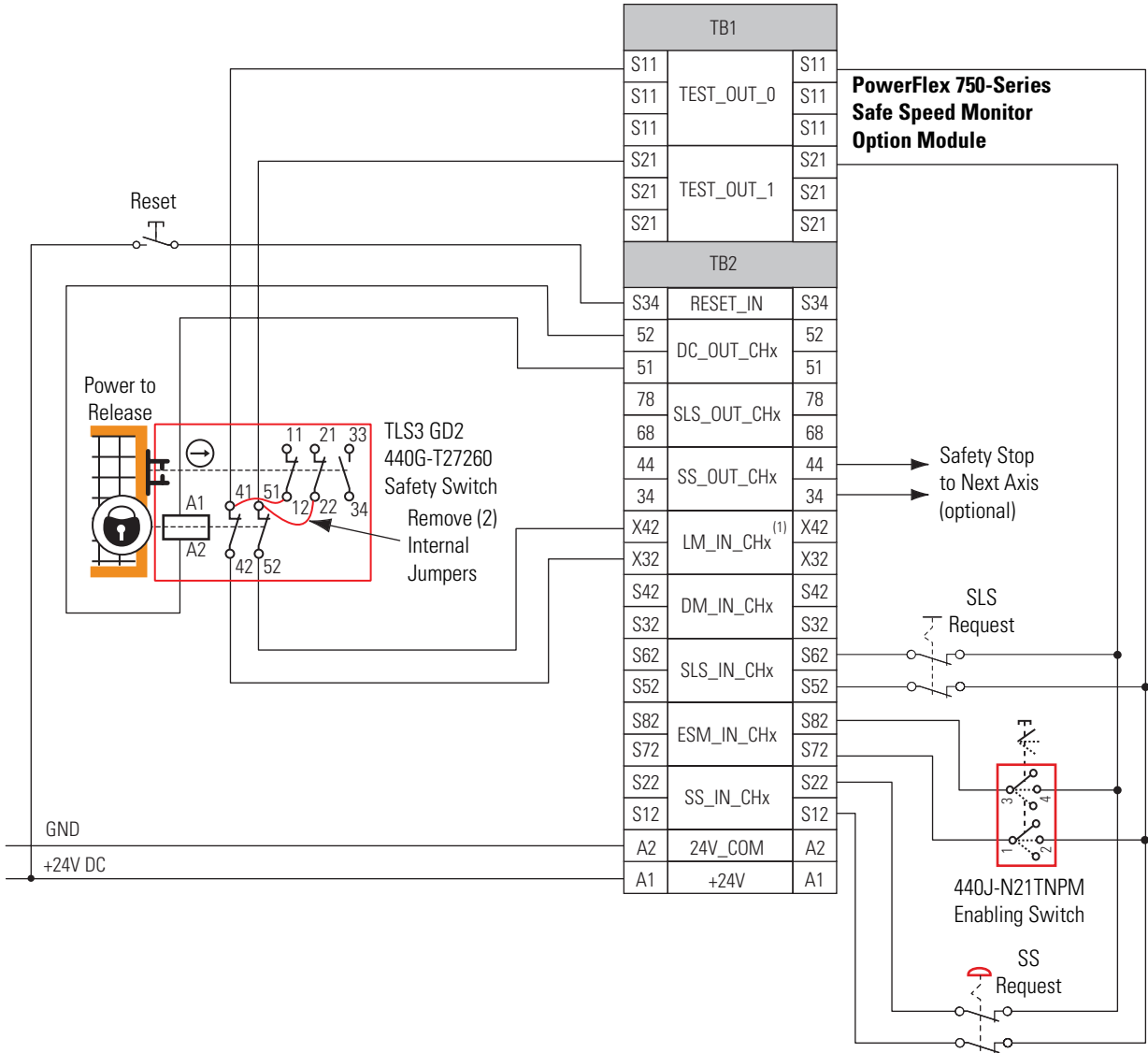

(1) Lock monitoring connections are not required for Safe Limited Speed with Enabling Switch Monitoring mode operation.

Safe Limited Speed with Door Monitoring and Enabling Switch Monitoring Mode

When properly configured for Safe Limited Speed with Door Monitoring and Enabling Switch Monitoring, the safety option performs Safe Limited Speed (SLS) monitoring functions as described on [page 75](#), in addition to the Safe Stop functions as described in Safe Stop Mode on [page 61](#).

The safety option also monitors both the Enabling Switch Monitor input (ESM_In) and the Door Monitor input (DM_In). This mode lets you access the hazardous area when the machine is under a Safe Limited Speed condition. The following is a typical procedure for accessing the hazardous area by using this mode.

1. Set the SLS_In input to OFF.

The Safe Speed Limit must not be exceeded after the P53 [LimSpd Mon Delay], if configured, times out.

2. After the Safe Limited Speed Monitoring Delay has timed out, hold the enabling switch in the middle position

Once a safe speed is detected and the enabling switch is in the middle position, the safety option unlocks the door.

3. Continue to hold the enabling switch while you open the door, enter the hazard area, and perform the required maintenance.

Follow these steps to remove the safe speed condition and resume normal run operation.

1. Leave the hazard area while holding the enabling switch.
2. Hold the enabling switch until the door is closed and you have disabled the SLS_In input by setting it to the ON or closed position.
3. Press the reset button, if manual reset is configured.
4. Release the enabling switch.

The machine resumes normal run operation.



ATTENTION: Make sure that the SLS_In input cannot transition to ON while someone is in the hazard area.

Use appropriate procedures when selecting safe limited speed to prevent other users from changing the mode while personnel are in the machine area.

Figure 23 - Timing Diagram for Safe Limited Speed (SLS) with Door Monitoring and Enabling Switch Monitoring Mode

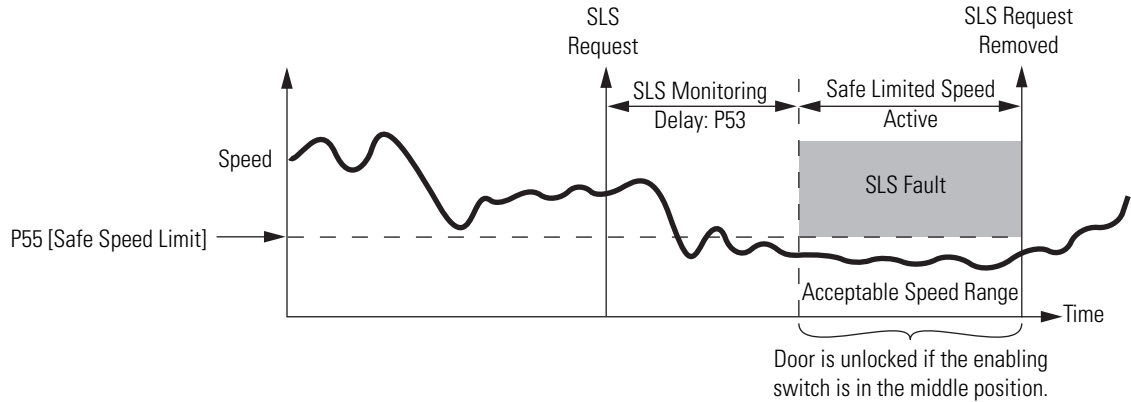

Behavior During SLS Monitoring

When Safe Limited Speed monitoring is active, door control logic is set to Unlock if the ESM_In input is ON and the speed is detected at below the Safe Speed Limit.

If the ESM_In input is ON, the door can be opened (DM_In transitions from ON to OFF). However, if the ESM_In input transitions to OFF after the door has been opened, an ESM Monitoring fault occurs. An ESM Monitoring fault is a Stop Category fault, which initiates the configured P45 [Safe Stop Type].

If the DM_In input transitions from ON to OFF (door is opened), while the ESM_In input is OFF, a Door Monitoring fault occurs. A Door Monitoring fault is a Stop Category fault, which initiates the configured P45 [Safe Stop Type].



ATTENTION: While Safe Limited Speed Monitoring is active, the ESM_In input is not monitored until the DM_In input is detected as OFF. Make sure that the ESM_In input is not relied upon for safety until the DM_In input has transitioned to OFF.

After the DM_In input turns OFF, it could turn back ON again if the door is closed behind the operator but the ESM_In input is still monitored.

Table 15 - Safe Limited Speed Operation

Safety Function Status	Drive In Safe State	Drive Able To Run (Ready)	Drive Able To Run (Ready)
DM_In	Off	On	Off
ESM_In	Off	On or Off	On

Behavior While SLS Monitoring is Inactive

If Safe Limited Speed monitoring is inactive, the DM_In input must be ON (door closed) or a Door Monitoring fault occurs and the safety option initiates the configured P45 [Safe Stop Type]. The ESM_In input can be ON or OFF.

Behavior During SLS Monitoring Delay

The status of the ESM_In input does not affect the operation of the system during a P53 [LimSpd Mon Delay]. However, the DM_In input must be ON (door closed) during the delay or a Door Monitoring fault occurs and the safety option initiates the configured P45 [Safe Stop Type].

Safe Stop Reset (SS Reset) and Safe Limited Speed Reset (SLS Reset)

The door must be closed when an SS Reset or SLS Reset is requested. An SS Reset results in a Door Monitoring fault if the door is open when the reset is requested by a transition of the SS_In input from OFF to ON. An SLS Reset also results in a Door Monitoring fault if the door is open when the reset is requested by a transition of the SLS_In input from OFF to ON. A Door Monitor fault is a Stop Category fault, which initiates the configured P45 [Safe Stop Type].

If an SS Reset is attempted while the SLS_In input is OFF, an ESM Monitoring fault occurs. An ESM Monitoring fault is a Stop Category fault, which initiates the configured P45 [Safe Stop Type].

SLS with Door Monitoring and Enabling Switch Monitoring Parameter List

To configure the safety option for Safe Limited Speed with Door Monitoring and Enabling Switch Monitoring, set the P58 [DM Input] and P54 [Enable SW Input] parameters in addition to the Safe Stop parameters listed on [page 69](#) and the Safe Limited Speed parameters listed on [page 78](#).

File	Group	No.	Display Name Full Name Description	Values		Read-Write	Data Type
HOST GROUPS	General	21	Safety Mode Safety Mode Defines the primary operating mode of the speed monitoring safety functions.	Setting:	6 = "LimSpd DM ES"	RW	Real
	Door Control	58	DM Input Door Monitor Input Configuration for the Door Monitor input (DM_In). "2NC" (1) – Dual-channel equivalent "2NC 3s" (2) – Dual-channel equivalent 3 s "1NC+1NO" (3) – Dual-channel complementary "1NC+1NO 3s" (4) – Dual-channel complementary 3 s "2 OSSD 3s" (5) – Dual-channel SS equivalent 3 s "1NC" (6) – Single channel equivalent	Default: Options:	0 = "Not used" 0 = "Not used" 1 = "2NC" 2 = "2NC 3s" 3 = "1NC+1NO" 4 = "1NC+1NO 3s" 5 = "2 OSSD 3s" 6 = "1NC"	RW	Real
	Limited Speed	54	Enable SW Input Enable Switch Input Configuration for the Enabling Switch input (ESM_In). "2NC" (1) – Dual-channel equivalent "2NC 3s" (2) – Dual-channel equivalent 3 s "1NC+1NO" (3) – Dual-channel complementary "1NC+1NO 3s" (4) – Dual-channel complementary 3 s "2 OSSD 3s" (5) – Dual-channel SS equivalent 3 s "1NC" (6) – Single channel equivalent	Default: Options:	0 = "Not used" ⁽¹⁾ 0 = "Not used" 1 = "2NC" 2 = "2NC 3s" 3 = "1NC+1NO" 4 = "1NC+1NO 3s" 5 = "2 OSSD 3s" 6 = "1NC"	RW	Real

(1) You must configure this parameter with a non-zero value in this mode.

SLS with Door Monitoring and Enabling Switch Monitoring Wiring Example

This example illustrates wiring for SLS with door monitoring and enabling switch monitoring.

Figure 24 - Master, Safe Limited Speed with Door Monitoring and Enabling Switch Monitoring (First or Single Unit)

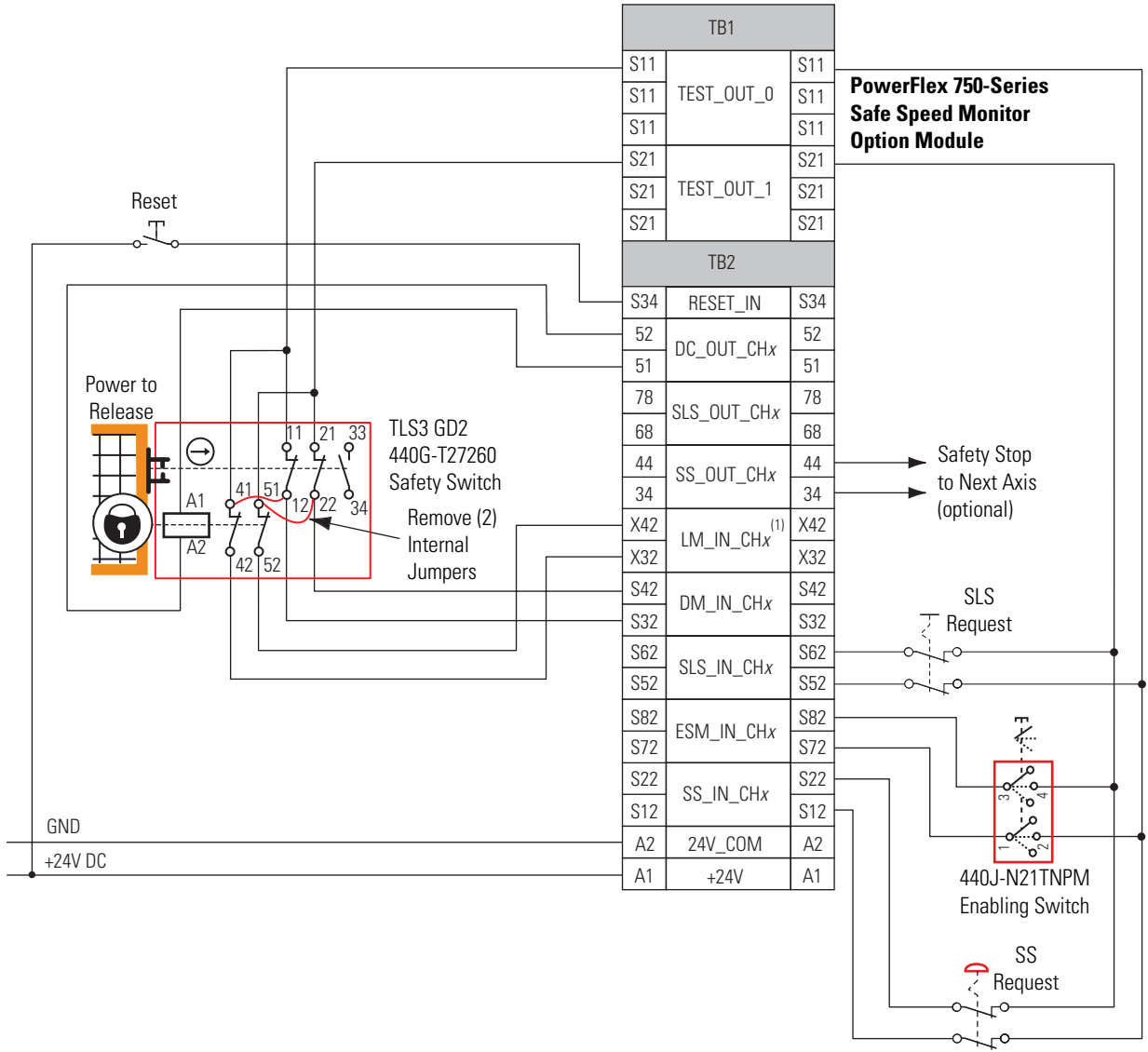

(1) Lock monitoring connections are not required for Safe Limited Speed with Door Monitoring and Enabling Switch Monitoring mode operation.

Safe Limited Speed Status Only Mode

When properly configured for Safe Limited Speed Status Only, the safety option provides Safe Limited Speed status information in addition to the Safe Stop functions as described in Safe Stop Mode on [page 61](#).

When the Safe Limited Speed input (SLS_In) is OFF, the feedback velocity is monitored and compared against a configurable Safe Speed Limit. If the measured velocity exceeds the limit, no stopping action takes place. Instead, the system status is made available as a safe output intended for a safety programmable logic controller (PLC).

You can program an optional P53 [LimSpd Mon Delay] to delay the start of Safe Limited Speed monitoring.

TIP In Safe Limited Speed Status Only mode, Door Monitoring and Enabling Switch Monitoring are not available.



ATTENTION: When the safety option is properly configured for Safe Limited Speed Status Only mode, it will not automatically initiate a Safe Stop in the event of an overspeed condition.

Safe Limited Speed monitoring is requested by a transition of the SLS_In input from ON to OFF. If you configure a P53 [LimSpd Mon Delay], the delay begins when Safe Limited Speed monitoring is requested by the SLS_In input transition from ON to OFF. The safety option begins monitoring for Safe Limited Speed when the delay times out. The SLS_Out output is ON if Safe Limited Speed monitoring is active and the speed is below the configured Safe Speed Limit, considering hysteresis.

Figure 25 - Timing Diagram for Safe Limited Speed Status Only

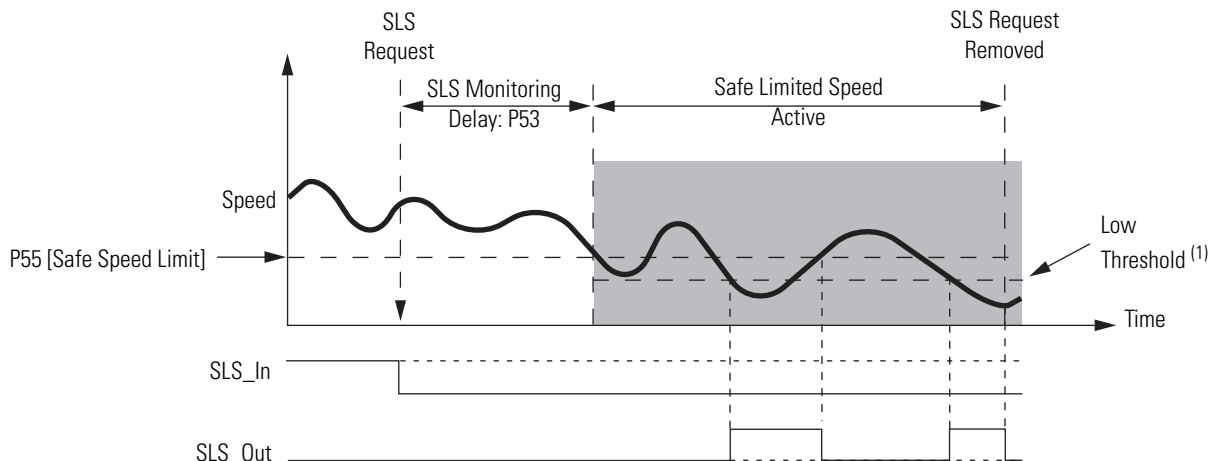

(1) Low Threshold = (P56 [Speed Hysteresis]/100) x P55 [Safe Speed Limit]

Speed Hysteresis

The P56 [Speed Hysteresis] parameter provides hysteresis for the SLS_Out output when the safety option is configured for SLS Status Only and Safe Limited Speed monitoring is active. The SLS_Out output is turned ON if the speed is less than the Low Threshold, which equals $[(\text{Speed Hysteresis}/100) \times \text{Safe Speed Limit}]$. The SLS_Out output is turned OFF when the speed is greater than or equal to the configured P55 [Safe Speed Limit].

The SLS_Out output remains OFF if Safe Limited Speed monitoring begins when the detected speed is less than the configured Safe Speed Limit but greater than or equal to the Low Threshold $[(\text{Speed Hysteresis}/100) \times \text{Safe Speed Limit}]$.

The SLS_Out output is held in its last state when the speed is less than the configured Safe Speed Limit and the speed is greater than or equal to the Low Threshold $[(\text{Speed Hysteresis}/100) \times \text{Safe Speed Limit}]$.

SLS Status Only Parameter List

To configure the safety option for Safe Limited Speed Status Only monitoring, set these parameters in addition to the Safe Stop parameters listed on [page 69](#).

File	Group	No.	Display Name Full Name Description	Values	Read-Write	Data Type
HOST GROUPS	General	21	Safety Mode Safety Mode Defines the primary operating mode of the speed monitoring safety functions.	Setting: 7 = "Lim Spd Stat"	RW	Real
	Limited Speed	52	Lim Speed Input Limited Speed Input Configuration for Safe Limited Speed input (SLS_In). "2NC" (1) – Dual-channel equivalent "2NC 3s" (2) – Dual-channel equivalent 3 s "1NC+1NO" (3) – Dual-channel complementary "1NC+1NO 3s" (4) – Dual-channel complementary 3 s "2 OSSD 3s" (5) – Dual-channel SS equivalent 3 s "1NC" (6) – Single channel equivalent	Default: 0 = "Not used" ⁽¹⁾ Options: 0 = "Not used" 1 = "2NC" 2 = "2NC 3s" 3 = "1NC+1NO" 4 = "1NC+1NO 3s" 5 = "2 OSSD 3s" 6 = "1NC"	RW	Real
		53	LimSpd Mon Delay Limited Speed Monitoring Delay Defines the Safe Limited Speed Monitoring Delay between the SLS_In ON to OFF transition and the initiation of the Safe Limited Speed (SLS) or Safe Maximum Speed (SMS) monitoring.	Units: Secs Default: 0 Min/Max: 0 / 6553.5	RW	Real
		55	Safe Speed Limit Safe Speed Limit Defines the speed limit that will be monitored in Safe Limited Speed (SLS) mode. Units are based on rotary or linear configuration defined by P29 [Fbk 1 Units].	Units: RPM mm/s Default: 0 Min/Max: 0 / 6553.5 RPM 0 / 6553.5 mm/s	RW	Real
		56	Speed Hysteresis Speed Hysteresis Provides hysteresis for SLS_Out output when Safe Limited Speed monitoring is active. 0% when P21 [Safety Mode] = 1, 2, 3, 4, 5, 6, 8, or 9 10...100% when P21 [Safety Mode] = 7 or 10	Units: % Default: 0 Min/Max: 0 / 100	RW	Real

(1) You must configure this parameter with a non-zero value in this mode.

SLS Status Only Wiring Examples

These examples illustrate wiring for SLS status only operation.

Figure 26 - Master, Safe Limited Speed Status Only (Single Unit)

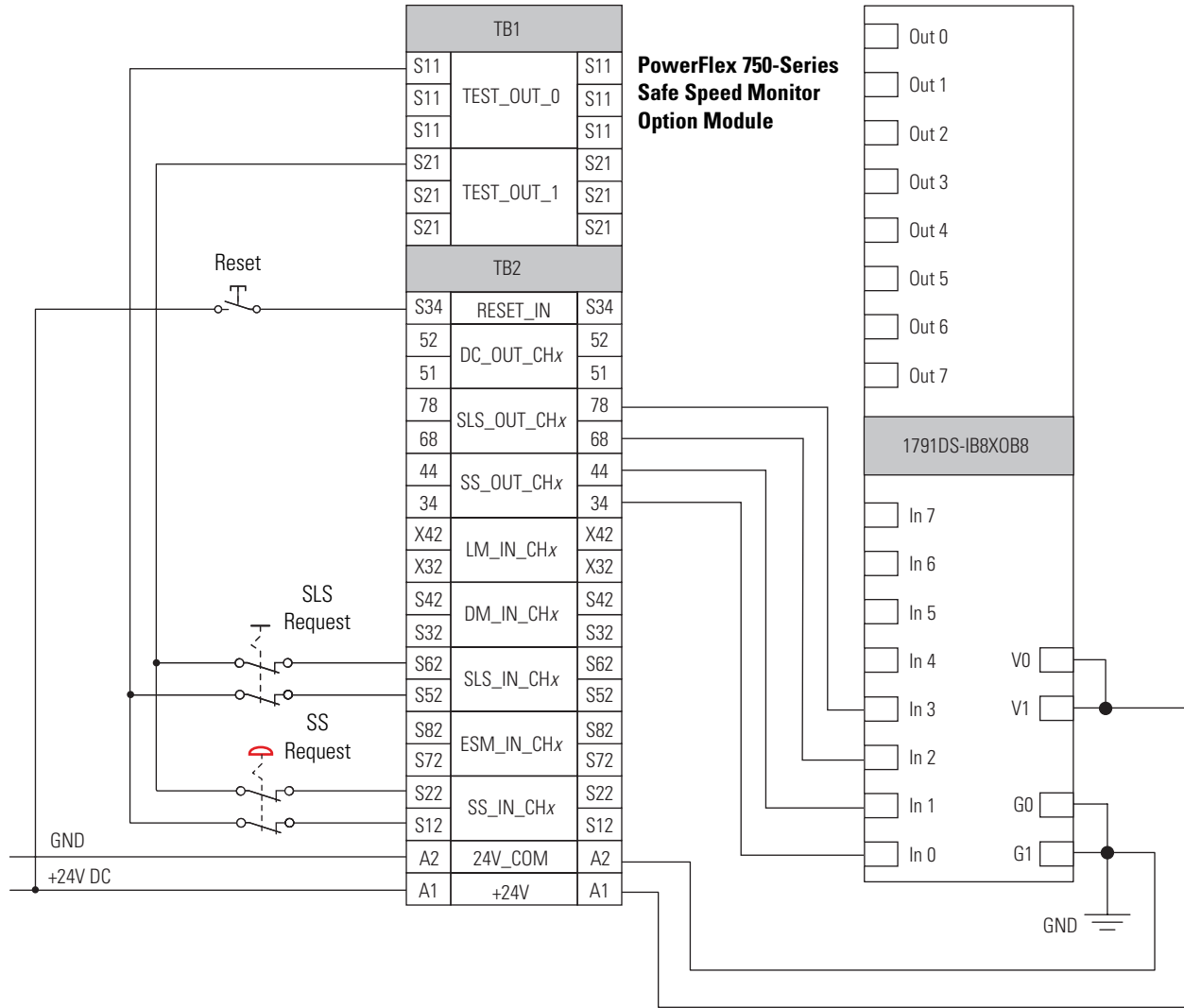
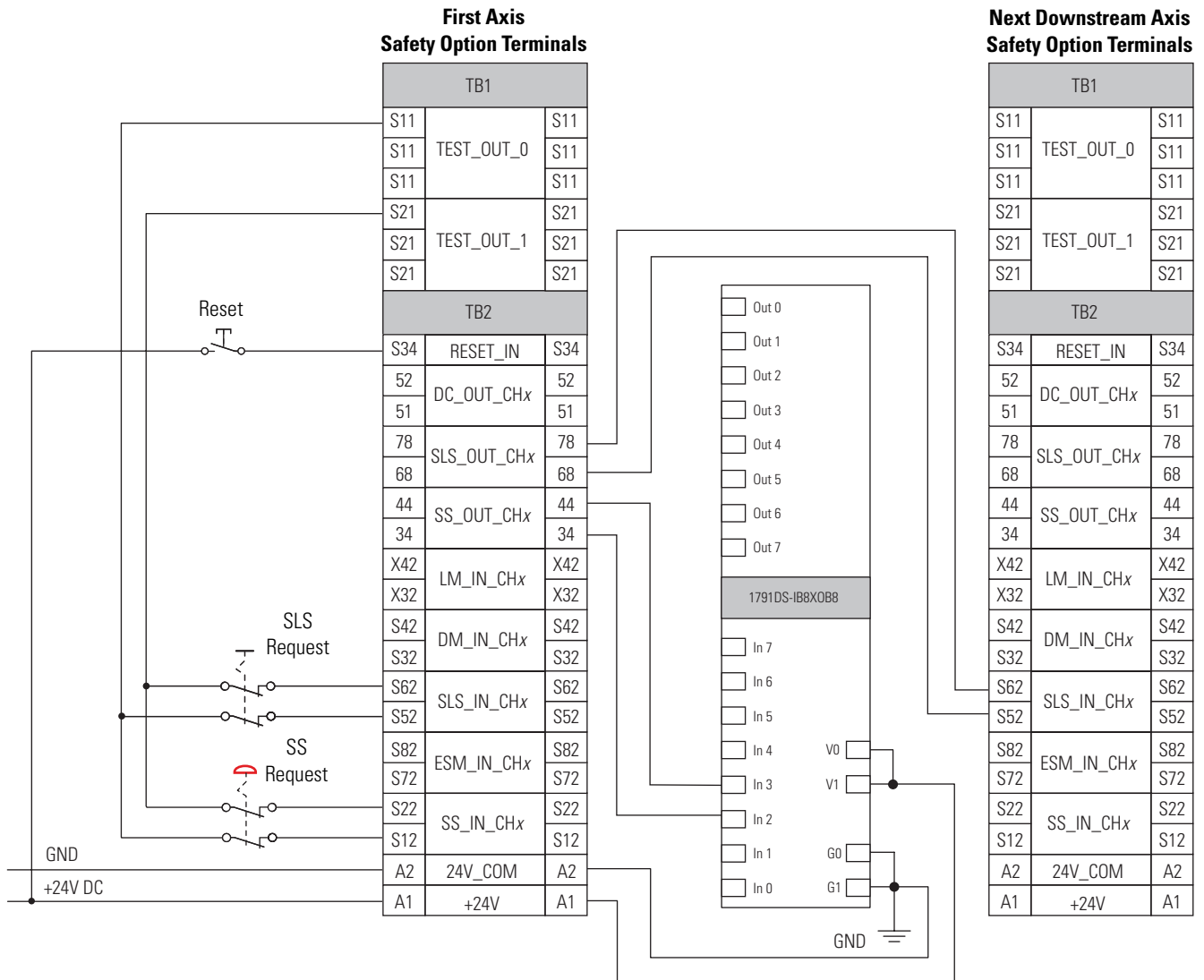

Figure 27 - Master, Safe Limited Speed Status Only (First Unit)



This example assumes that a programmable safety controller is monitoring all safety option functions and controlling the safety option. The SS_In and SLS_In inputs are connected to the I/O module; however, standard safety component inputs could also be used.

These functions are not performed by the safety option in this scenario:

- Guardlocking switch inputs
- Door locking
- Door status (open or closed)
- Enabling switch

Figure 28 - Safe Limited Speed Status Only with Programmable Controller Monitoring

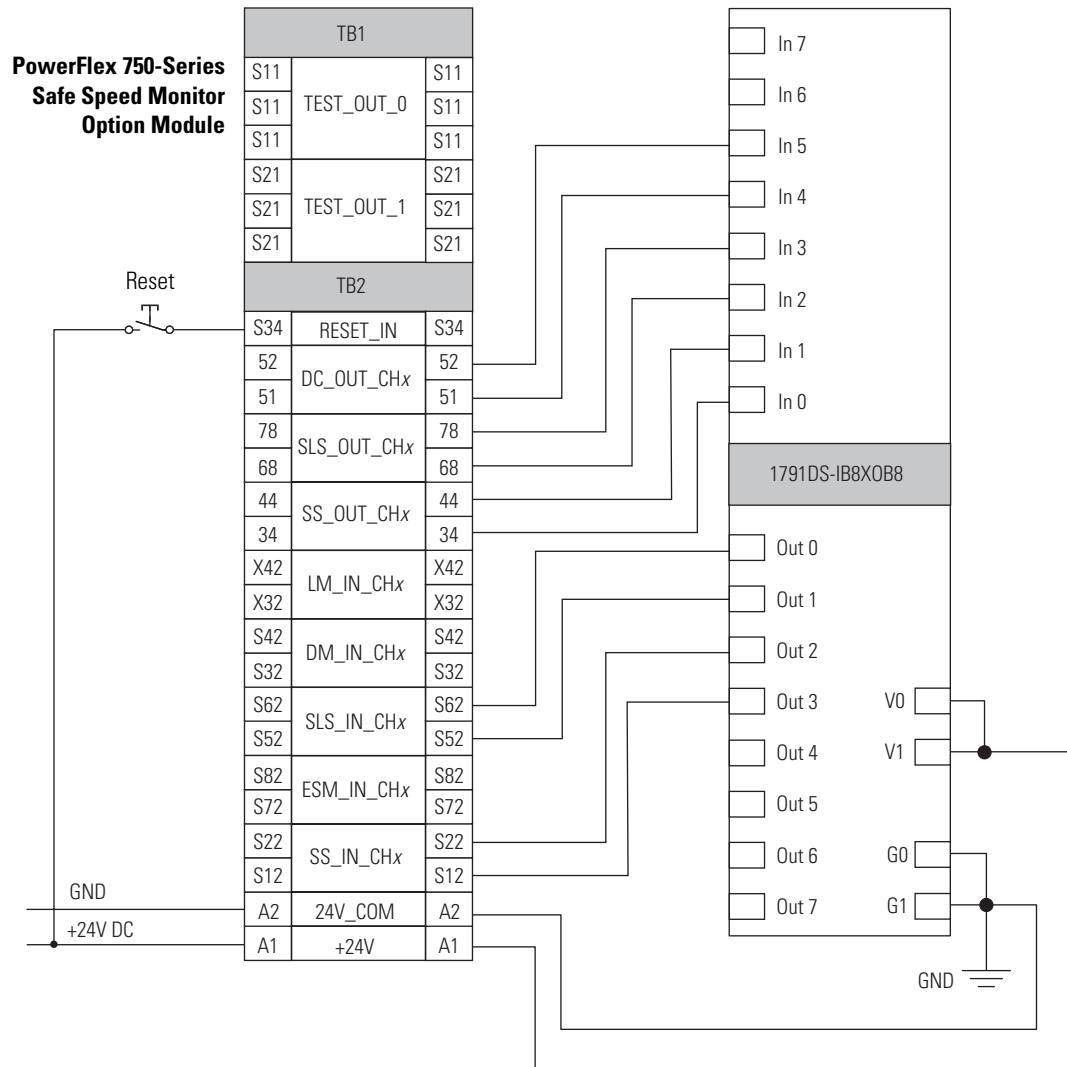

Slave Modes for Multi-axis Cascaded Systems

efesotomasyon.com

Introduction

This chapter describes the slave modes of safety operation and wiring examples of cascaded multi-axis configurations.

Topic	Page
Cascaded Configurations	97
Slave, Safe Stop Mode	98
Slave, Safe Stop Parameter List	99
Slave, Safe Stop Wiring Examples	101
Slave, Safe Limited Speed Mode	104
Slave, Safe Limited Speed Parameters	104
Slave, Safe Limited Speed Wiring Examples	105
Slave, Safe Limited Speed Status Only Mode	107
Slave, Safe Limited Speed Status Only Parameter List	107
Slave, Safe Limited Speed Status Only Wiring Examples	108
Multi-axis Connections	110

Cascaded Configurations

Use the P20 [Cascaded Config] parameter to define the safety option's position in the system as Single Unit (Single), Cascaded First Unit (Multi First), Cascaded Middle Unit (Multi Mid), or Cascaded Last Unit (Multi Last). Only the middle or last safety option in a multi-axis system can be configured for slave modes.

For cascaded safety options, connect the safety switches to the safety inputs (SS_In, SLS_In, DM_In, ESM_In, and LM_In) of the first (master) axis only. Each feedback for Safe Stop functions are connected to their respective axis. The inputs are cascaded from one safety option to the next by connecting the outputs from the previous safety option to the inputs of the next safety option.

Figure 29 - Cascaded Connections

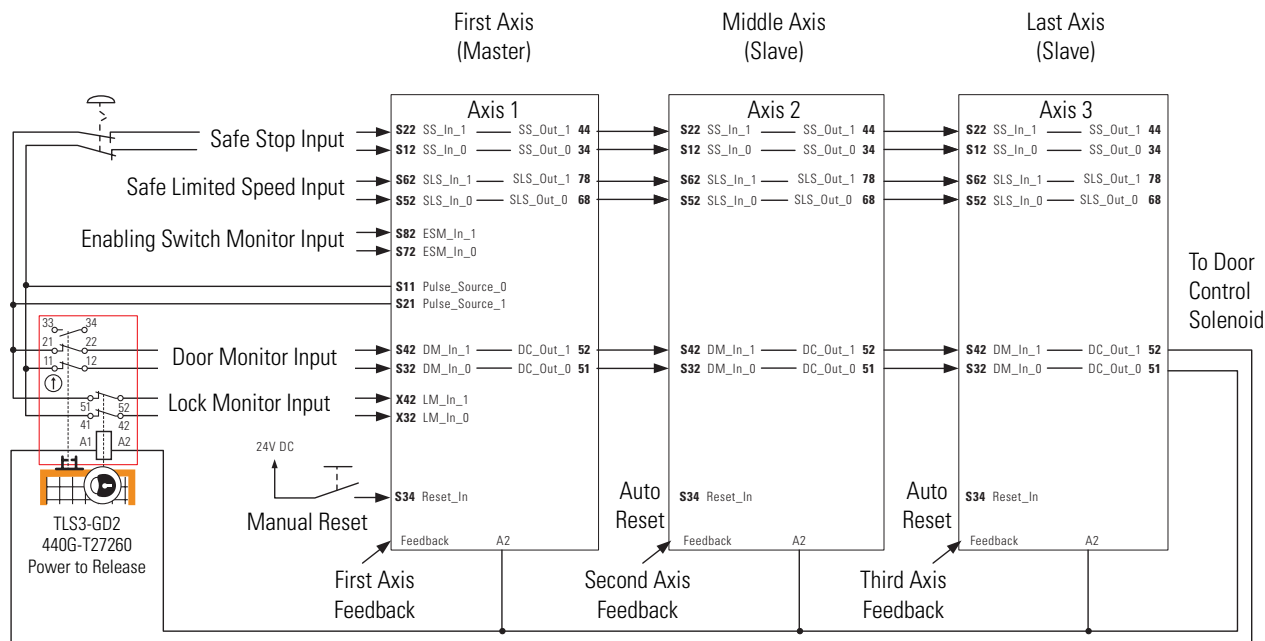

The inputs from the safety switches are monitored by the first safety option, which is the master. A Safe Limited Speed Reset detected by the first safety option is cascaded to the subsequent safety options via the SLS_Out to SLS_In chain. Although all units can be configured for any reset type, we recommend using automatic reset in all slave units to follow the master units reset type.

Any fault or transition of the SS_In input to OFF is detected by the first safety option and initiates the configured P45 [Safe Stop Type] to all of the safety options via the SS_Out to SS_In chain.

Any fault in a slave safety option initiates the configured P45 [Safe Stop Type] only to that safety option and to slave safety options further down the chain.

IMPORTANT Safe Stop monitoring is not initiated for non-faulted units earlier in the cascaded chain.

IMPORTANT The safety reaction time for a cascaded system includes the sum of the reaction times of each safety option in the chain.

Slave, Safe Stop Mode

When properly configured for Slave, Safe Stop mode, the safety option performs the same functions as Safe Stop except that the safety option regards the Door Monitor input as a Door Control output from an upstream axis, and performs a logical AND with its internal Door Control signal to form the cascaded Door Control output. This makes sure that the Door Control output commands the door to unlock only if all units command the door to unlock.

Slave, Safe Stop Parameter List

To configure the safety option for a Slave, Safe Stop mode, set these parameters. See Multi-axis Connections on [page 110](#) for details on configuring slave safety options.

File	Group	No.	Display Name Full Name Description	Values	Read-Write	Data Type
HOST GROUPS	General	20	Cascaded Config Cascaded Configuration Defines whether the speed monitoring safety option is a single unit or if it occupies a first, middle, or last position in a multi-axis cascaded system.	Options: 2 = "Multi Mid" 3 = "Multi Last"	RW	Real
		21	Safety Mode Safety Mode Defines the primary operating mode of the speed monitoring safety functions.	Option: 8 = "Slv Safe Stp"	RW	Real
	Stop	44	Safe Stop Input Safe Stop Input Configuration for Safe Stop input (SS_In). "2 OSSD 3s" (5) – Dual-channel SS equivalent 3 s	Options 5 = "2 OSSD 3s"	RW	Real
		45	Safe Stop Type Safe Stop Type Safe operating stop type selection. This defines the type of Safe Stop that is performed if the Safe Stop function is initiated by a stop type condition.	Default: 0 = "Torque Off" Options: 0 = "Torque Off" 1 = "Safe Stop 1" 2 = "Safe Stop 2" 3 = "Torque Off NoCk"	RW	Real
		46	Stop Mon Delay Stop Monitoring Delay Defines the monitoring delay between the request and the Max Stop Time when the request for a Safe Stop 1 or a Safe Stop 2 is initiated by an SS_In input ON to OFF transition. If the Safe Stop Type is Safe Torque Off With or Without Standstill Speed Checking, the Stop Monitor Delay must be 0 or a Invalid Configuration Fault occurs.	Units: Secs Default: 0 Min/Max: 0 / 6553.5	RW	Real
		47	Max Stop Time Maximum Stop Time Defines the maximum stop delay time that is used when the Safe Stop function is initiated by a stop type condition.	Units: Secs Default: 0 Min/Max: 0 / 6553.5	RW	Real
		48	Standstill Speed Standstill Speed Defines the speed limit that is used to declare motion as stopped. Units are based on rotary or linear configuration defined by P29 [Fbk 1 Units]. Not valid for Safe Torque Off without Standstill Checking.	Units: RPM mm/s Default: 0.001 Min/Max: 0.001/ 65.535 RPM 000/ 65.535 mm/s	RW	Real
		49	Standstill Pos Standstill Position Defines the position limit window in encoder 1 degrees or mm that will be tolerated after a safe stop condition has been detected. Degrees (360° = 1 revolution) or mm based on rotary or linear configuration defined by P29 [Fbk 1 Units]. Not valid for Safe Torque Off without Standstill Checking.	Units: Deg mm Default: 10 Min/Max: 0 / 65,535 deg 0 / 65.535 mm	RW	Real
		50	Decel Ref Speed Deceleration Reference Speed Determines deceleration rate to monitor for Safe Stop 1 or Safe Stop 2. Units are based on rotary or linear configuration defined by encoder 1 feedback configuration, P29 [Fbk 1 Units].	Units: RPM mm/s Default: 0 Min/Max: 0 / 65,535 RPM 0 / 65,535 mm/s	RW	Real
		51	Stop Decel Tol Stop Deceleration Tolerance This is the acceptable tolerance above the deceleration rate set by the Decel Ref Speed parameter.	Units: % Default: 0 Min/Max: 0 / 100	RW	Real

File	Group	No.	Display Name Full Name Description	Values		Read-Write	Data Type
HOST GROUPS	Door Control	57	Door Out Type Door Output Type Defines the lock and unlock state for door control output (DC_Out). When Door Out Type equals power to release, DC_Out is OFF in the lock state and ON in the unlock state. When Door Out Type equals power to lock, DC_Out is ON in the lock state and OFF in the unlock state. The first and middle units of a multi-axis system must be configured as cascading (2).	Default:	0 = "Pwr to Rel"	RW	Real
				Options:	0 = "Pwr to Rel" 1 = "Pwr to Lock" 2 = "2 Ch Sourcing"		
		58	DM Input Door Monitor Input Configuration for the Door Monitor input (DM_In). "2 OSSD 3s" (5) – Dual-channel SS equivalent 3 s	Options:	5 = "2 OSSD 3s"	RW	Real

Slave, Safe Stop Wiring Examples

These examples show two different Slave, Safe Stop configurations.

The first example shows the safety option configured as a cascaded middle unit via the P20 [Cascaded Config] parameter (Multi Mid). It has SS_In and DM_In input connections from the previous upstream safety option, as well as SS_Out and DC_Out output connections to the next downstream safety option. This unit is configured with automatic reset so it follows the function of the previous axis.

See Safe Stop with Door Monitoring Wiring Example on [page 74](#) for an example of a first (master) unit.

Figure 30 - Slave, Safe Stop, Middle Unit

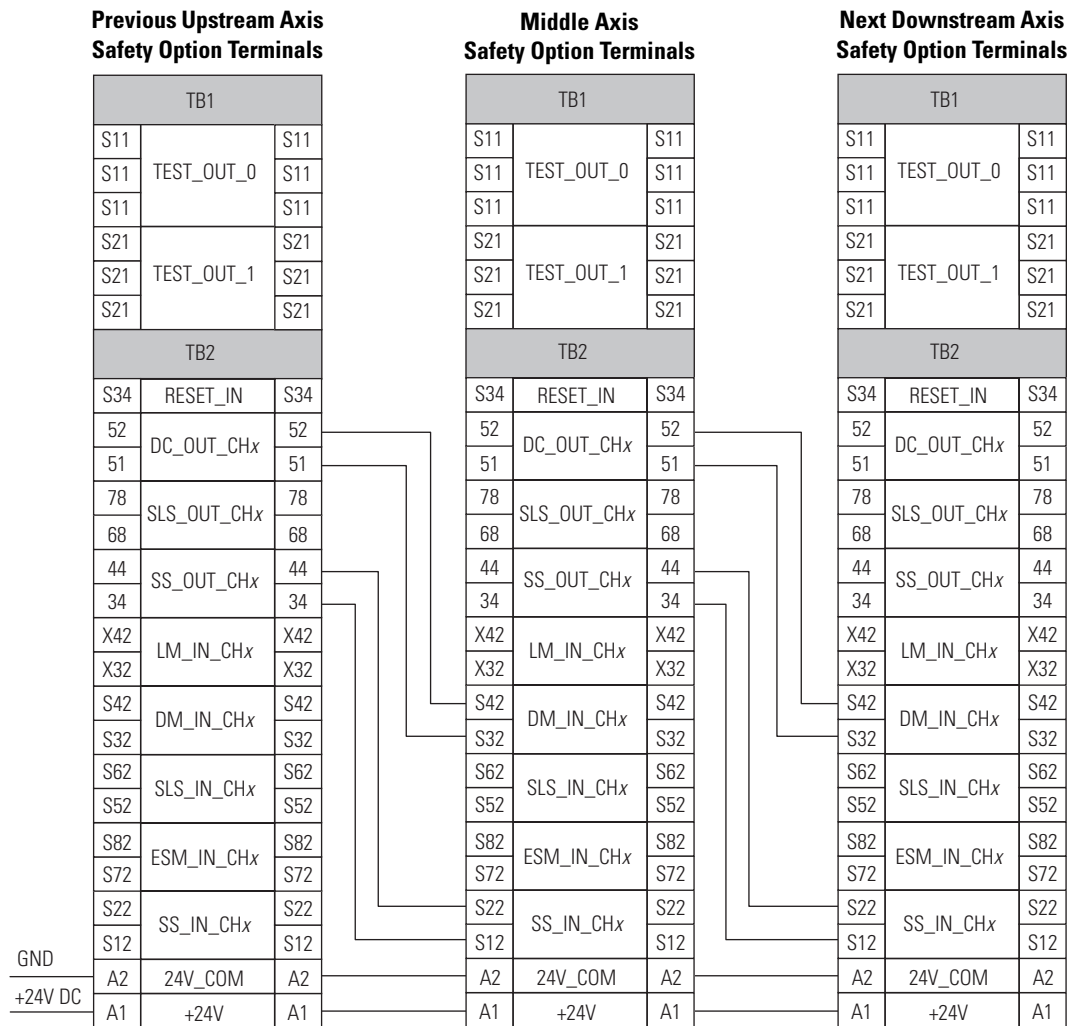

This example shows the last cascaded slave safety option in the system. It has SS_In and DM_In inputs from the previous upstream safety option, but its DC_Out output is connected to a guardlocking interlock switch. This unit is configured with automatic reset so it follows the function of the previous axis.

Figure 31 - Slave, Safe Stop, Last Unit

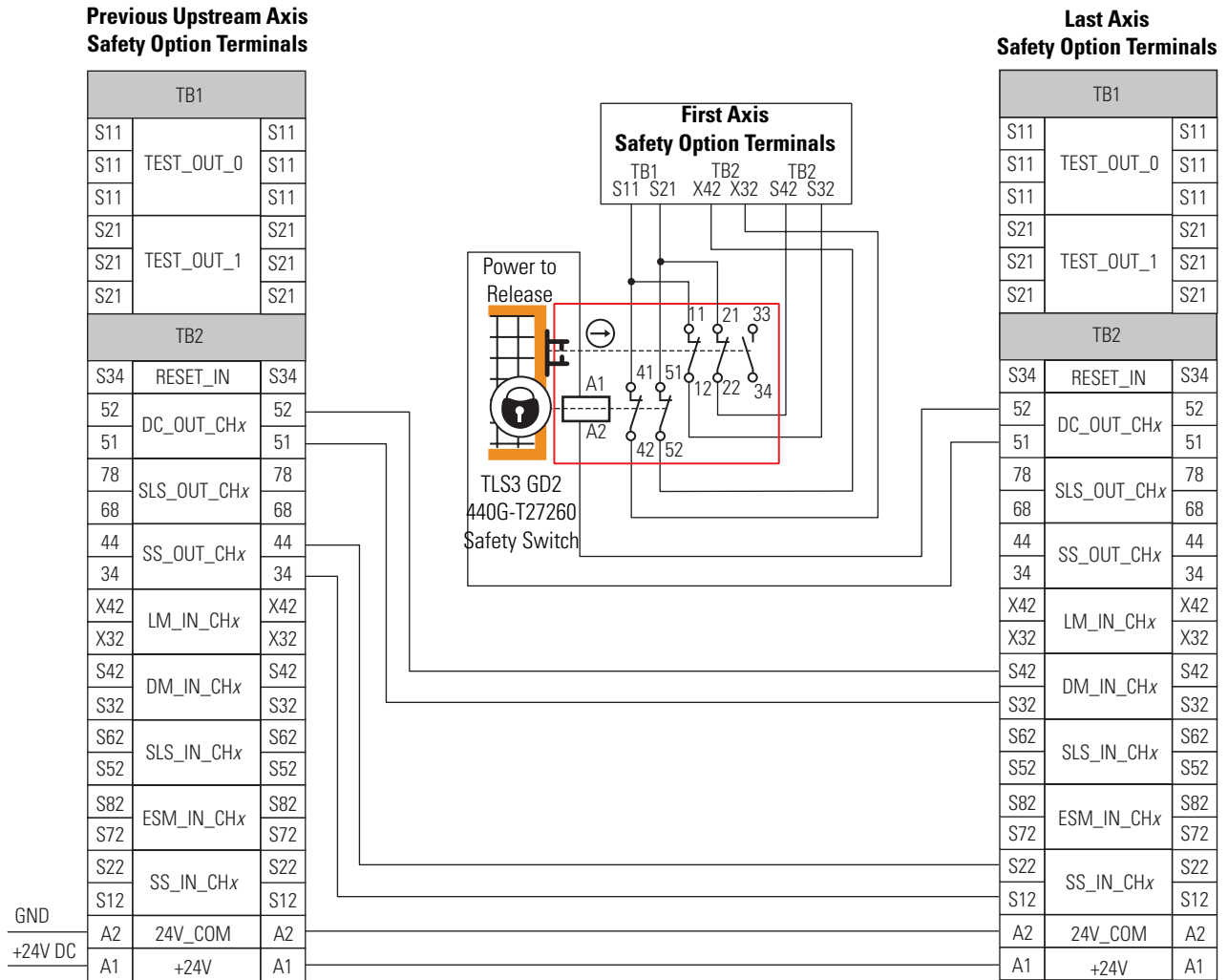

This example shows three safety options connected together in a cascaded system.

IMPORTANT All safety option modules must share a common ground.

Figure 32 - First, Middle, and Last Safety Options in a Cascaded System with Door Control and Lock Monitoring

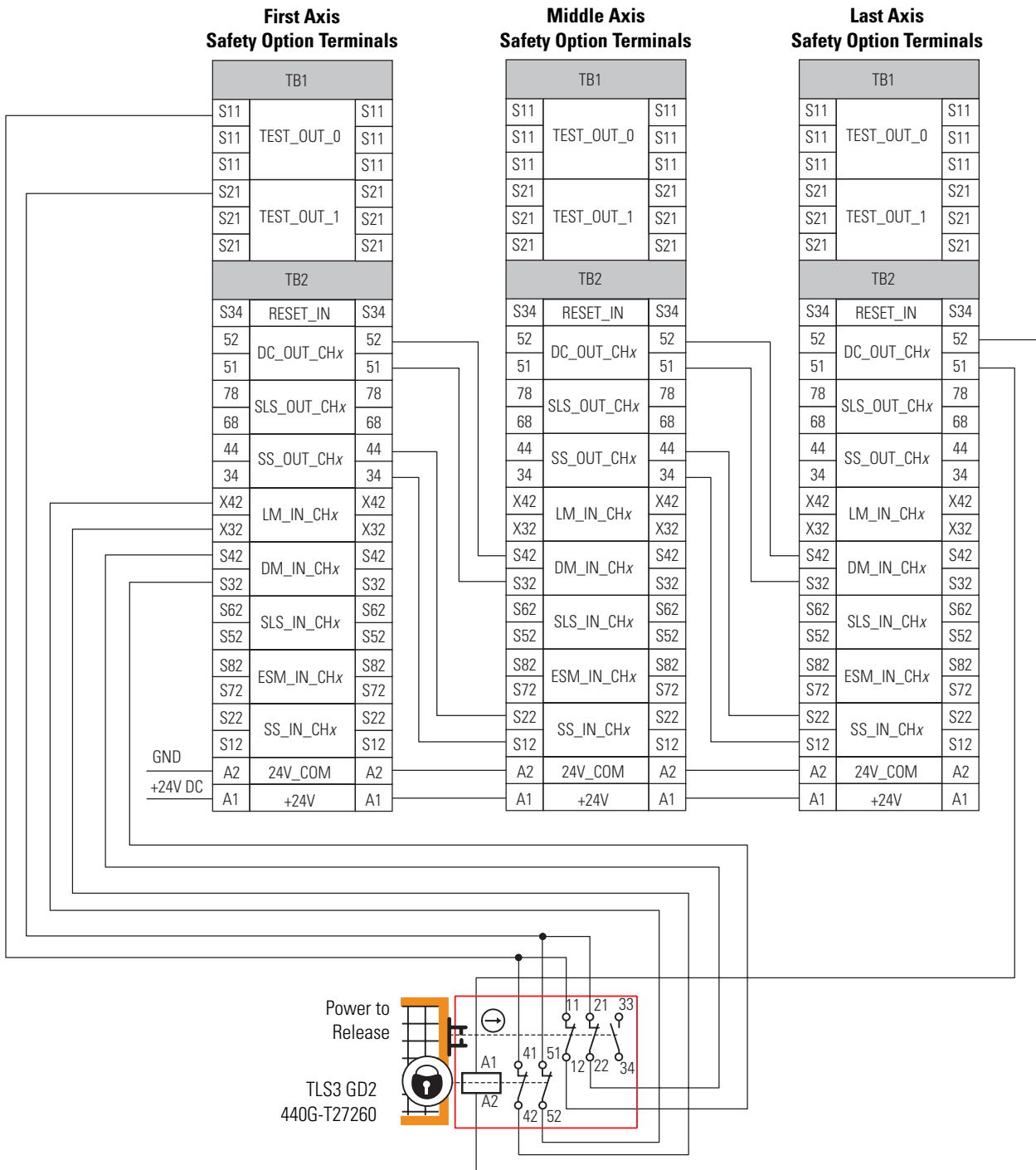

Slave, Safe Limited Speed Mode

When properly configured for Slave, Safe Limited Speed mode, the safety option performs the same functions as Safe Limited Speed mode as described on [page 75](#).

However, the safety option regards the Door Monitor input as a Door Control output from an upstream axis, and performs a logical AND with its internal Door Control signal to form the cascaded Door Control output. Door Monitoring, Enabling Switch Monitoring, and Lock Monitoring functions are not allowed in this mode.

For the door to unlock, all axes must be below safe limited speed.

TIP Only the middle and last safety option in a multi-axis system can be configured for slave modes.

Slave, Safe Limited Speed Parameters

To configure the safety option for Slave, Safe Limited Speed monitoring, set these parameters in addition to the Slave, Safe Stop parameters listed on [page 99](#). See Multi-axis Connections on [page 110](#) for details on configuring slave safety options.

File	Group	No.	Display Name Full Name Description	Values		Read-Write	Data Type
HOST GROUPS	General	20	Cascaded Config Cascaded Configuration Defines whether the speed monitoring safety option is a single unit or if it occupies a first, middle, or last position in a multi-axis cascaded system.	Options:	2 = "Multi Mid" 3 = "Multi Last"	RW	Real
		21	Safety Mode Safety Mode Defines the primary operating mode of the speed monitoring safety functions. "Slv Lim Spd" (9) - Slave, Safe Limited Speed	Option:	9 = "Slv Lim Spd"	RW	Real
	Limited Speed	52	Lim Speed Input Limited Speed Input Configuration for Safe Limited Speed input (SLS_In). "2 OSSD 3s" (5) – Dual-channel SS equivalent 3 s	Option:	5 = "2 OSSD 3s"	RW	Real
		53	LimSpd Mon Delay Limited Speed Monitoring Delay Defines the Safe Limited Speed Monitoring Delay between the SLS_In ON to OFF transition and the initiation of the Safe Limited Speed (SLS) or Safe Maximum Speed (SMS) monitoring.	Units: Default: Min/ Max:	Secs 0 0 / 6553.5	RW	Real
		55	Safe Speed Limit Safe Speed Limit Defines the speed limit that will be monitored in Safe Limited Speed (SLS) mode. Units are based on rotary or linear configuration defined by P29 [Fbk 1 Units].	Units: Default: Min/ Max:	RPM mm/s 0 0 / 6553.5 RPM 0 / 6553.5 mm/s	RW	Real

Slave, Safe Limited Speed Wiring Examples

These examples show two different Slave, Safe Limited Speed configurations.

The first example is configured as a cascaded middle unit via the P20 [Cascaded Config] parameter (Multi Mid). It has SS_In, SLS_In, and DM_In input connections from the previous upstream safety option, as well as SS_Out, SLS_Out, and DC_Out output connections to the next downstream safety option.

See SLS with Door Monitoring Wiring Example on [page 83](#) for an example of a first (master) unit.

Figure 33 - Slave, Safe Limited Speed, Middle Unit

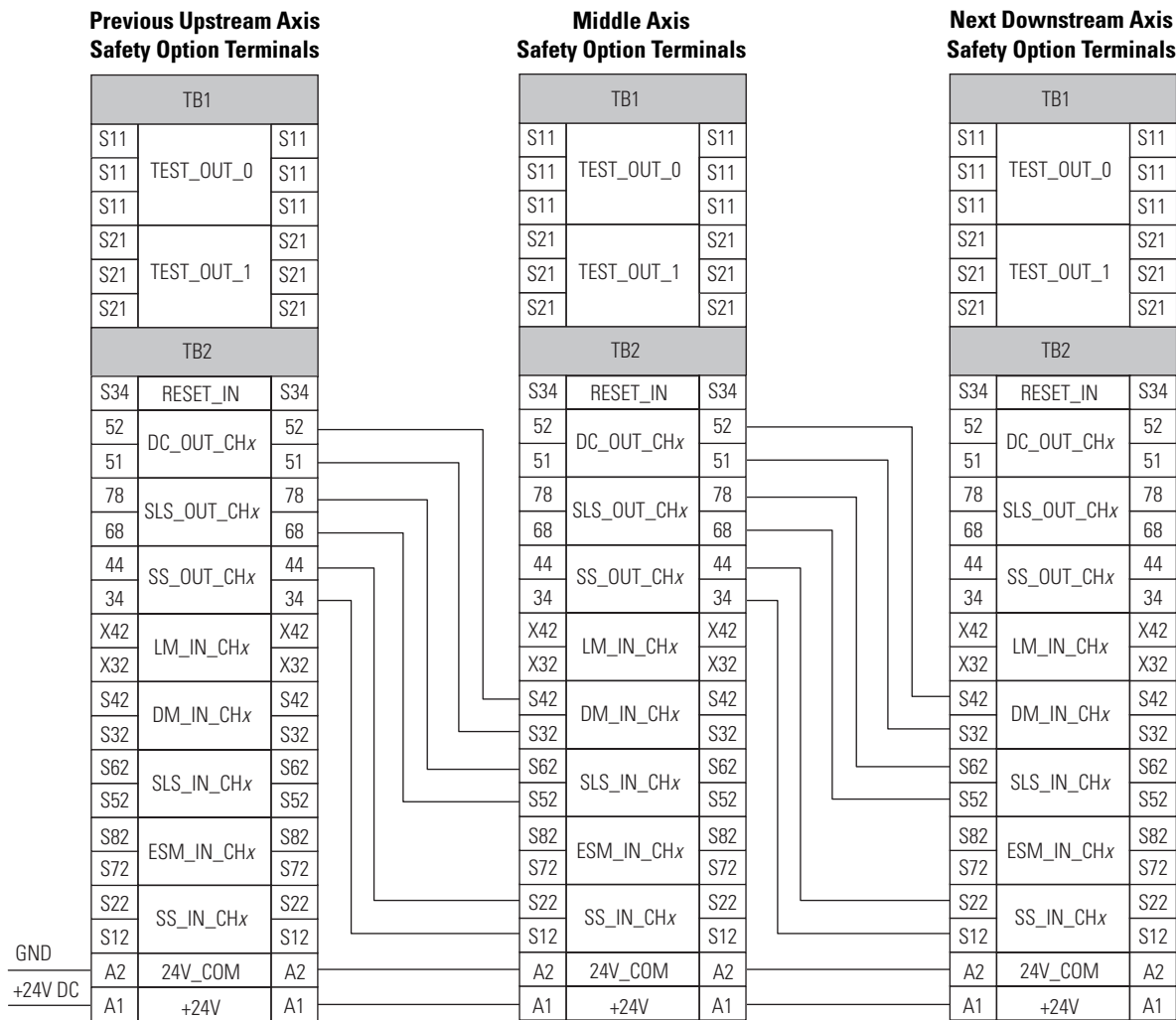

This second example is configured as a cascaded last unit via the P20 [Cascaded Config] parameter (Multi Last). It has SS_In, SLS_In, and DM_In input connections from the previous upstream safety option, but its DC_Out output is connected to a guardlocking interlock switch.

Figure 34 - Slave, Safe Limited Speed, Last Unit

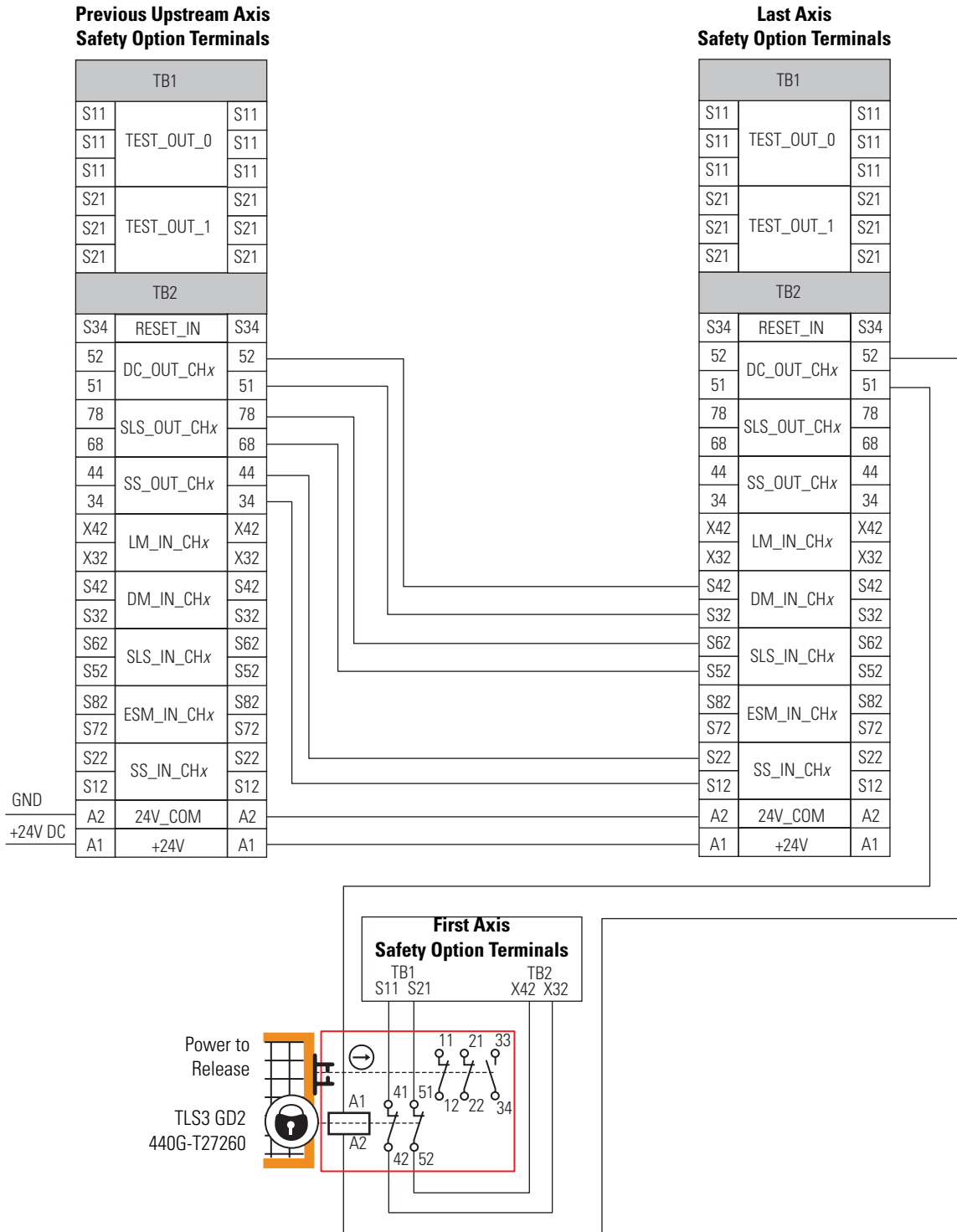

Slave, Safe Limited Speed Status Only Mode

When properly configured for Slave, Safe Limited Speed Status Only mode, the Safe Speed Monitor Option module performs the same functions as Safe Limited Speed Status Only mode as described on [page 91](#). However, the safety option regards the Door Monitor input as a Door Control output from an upstream axis, and performs a logical AND with its internal Door Control signal to form the cascaded Door Control output.

The SLS_Out output of the last safety option in a cascaded chain goes high only when all axes are below the Safe Speed Limit. In Safe Limited Speed Status Only mode, each subsequent unit does not enable Safe Limited Speed until the previous unit has reached the Safe Speed Limit.

Door Monitoring and Enabling Switch Monitoring functions are not allowed in this mode.

TIP Only the middle and last safety option in a multi-axis system can be configured for slave modes.

Slave, Safe Limited Speed Status Only Parameter List

To configure the safety option for Slave, Safe Limited Speed Status Only monitoring, set these parameters in addition to the Slave, Safe Stop parameters listed on [page 99](#) and the Slave, Safe Limited Speed parameters listed on [page 104](#). See Multi-axis Connections on [page 110](#) for details on configuring slave safety options.

File	Group	No.	Display Name Full Name Description	Values		Read-Write	Data Type
		HOST GROUPS	General	20	Cascaded Config Cascaded Configuration Defines whether the speed monitoring safety option is a single unit or if it occupies a first, middle, or last position in a multi-axis cascaded system.	Options:	2 = "Multi Mid" 3 = "Multi Last"
21	Safety Mode Safety Mode Defines the primary operating mode of the speed monitoring safety functions. "Slv Spd Stat" (10) - Slave, Safe Limited Speed Status Only			Option:	10 = "Slv Spd Stat"	RW	Real
Limited Speed	56		Speed Hysteresis Speed Hysteresis Provides hysteresis for SLS_Out output when Safe Limited Speed monitoring is active. 0% when P21 [Safety Mode] = 1, 2, 3, 4, 5, 6, 8, or 9 10...100% when P21 [Safety Mode] = 7 or 10	Units: Default: Min/ Max:	% 0 0 / 100	RW	Real

Slave, Safe Limited Speed Status Only Wiring Examples

These examples show two different Slave, Safe Limited Speed Status Only configurations.

The first example is configured as a cascaded middle unit via the P20 [Cascaded Config] parameter (Multi Mid). It has SS_In, SLS_In, and DM_In input connections from the previous upstream safety option, as well as SS_Out, SLS_Out, and DC_Out output connections to the next downstream safety option.

IMPORTANT The SLS_Out signals change state immediately based on the speed relative to the Safe Speed Limit if the Safe Limited Speed Monitoring Delay (SLS Mon Delay) is set to zero.

See SLS Status Only Wiring Examples starting on [page 94](#) for an example of a first (master) unit.

Figure 35 - Slave, Safe Limited Speed Status Only, Middle Safety Option

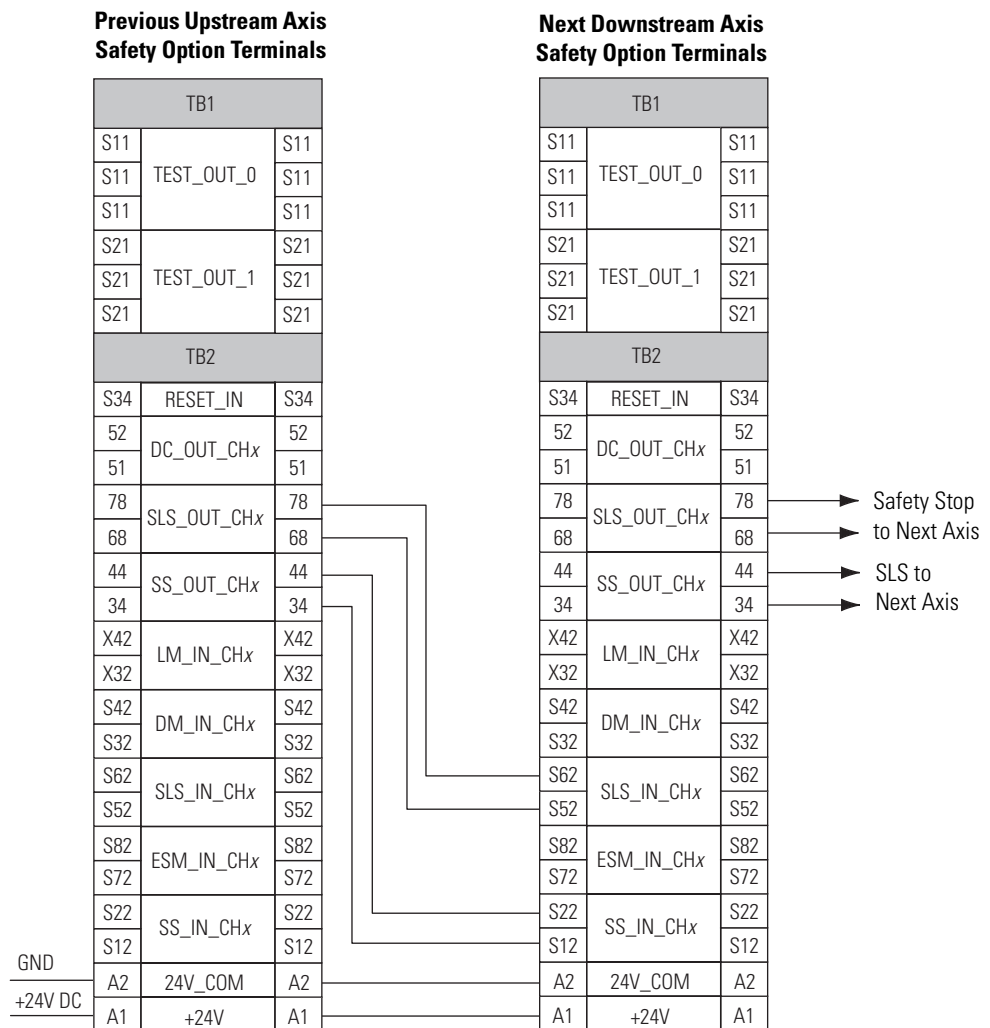

This second example is configured as a cascaded last unit via the P20 [Cascaded Config] parameter (Multi Last). It has SS_In, SLS_In, and DM_In input connections from the previous upstream safety option, but its SS_Out, SLS_Out, and DC_out outputs are connected to a Bulletin 1791DS module.

Figure 36 - Slave, Safe Limited Speed Status Only, Last Safety Option

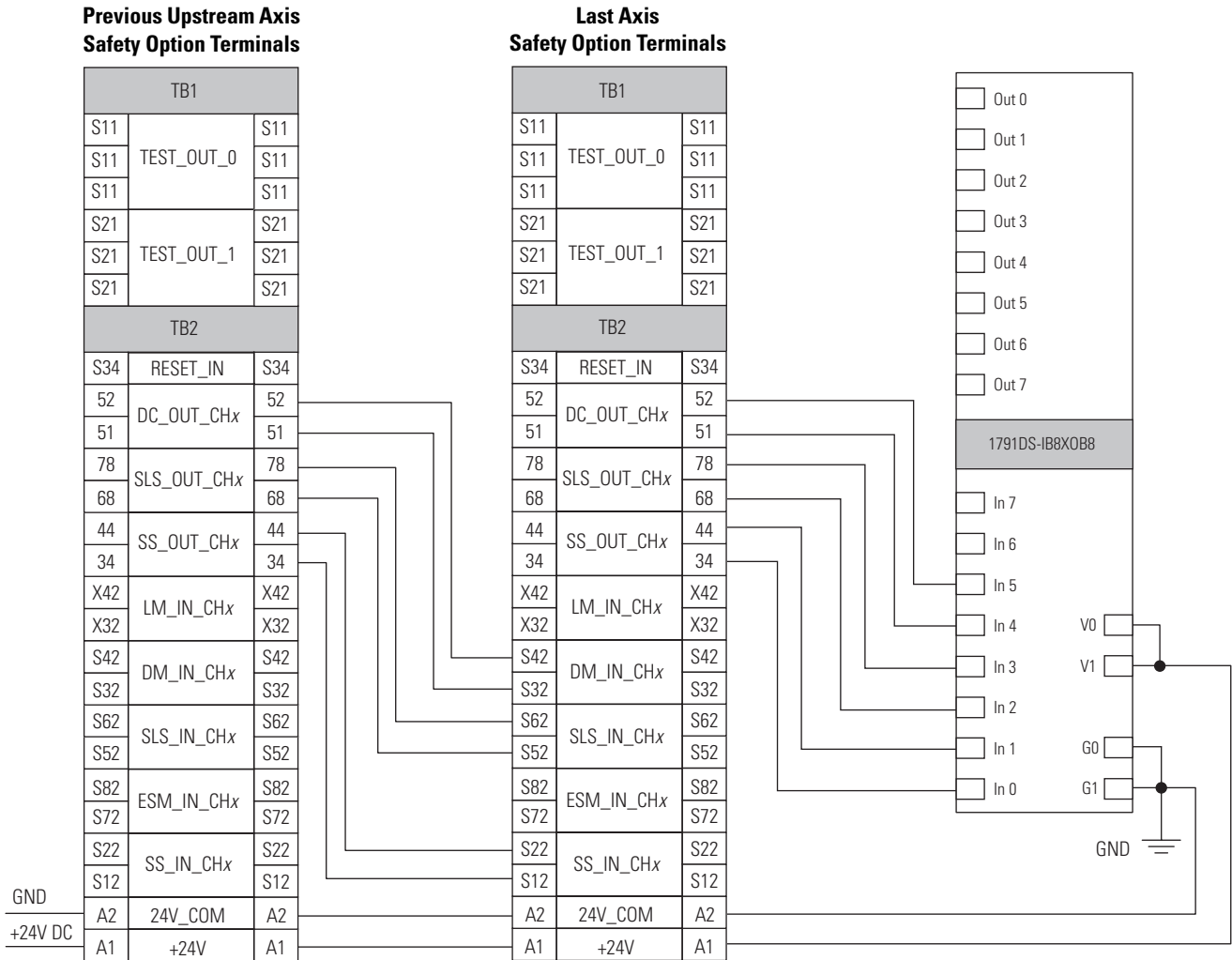

Multi-axis Connections

When configuring a multi-axis system, you need to consider the location of each safety option in the system. The type of cascaded connections that can be made are dependent upon the Safety mode configurations of the master and slave safety options and their positions in the system.

Middle and last units in the cascaded chain may be configured for Automatic reset. A single reset by the first unit also resets all following units in the chain. If a fault occurs after the first axis in the cascaded chain, only the subsequent axis enters the safe state. To reset all axes, you must cycle the SS_In input on the first axis.

For slave units in a multi-axis system, the SS_In, SLS_In, and DM_In input signal types (if used) must be configured for output switching signal devices (OSSD) because the output from the previous unit is also configured for OSSD.

For middle or last units in multi-axis systems, the safety option regards the Door Monitor input as a Door Control output from an upstream axis, and performs a logical AND with its internal Door Control signal to form the cascaded Door Control output.

For information on door control in the master unit, see Door Control on [page 67](#).

Typical Safety Mode Combinations		Cascaded Connections Allowed		
Master Safety Option	First Slave Safety Option ⁽¹⁾ (Second Safety Option in System)	SS_Out to SS_In	SLS_Out to SLS_In	DC_Out to DM_In ⁽²⁾
Safe Stop	Slave - Safe Stop	Yes	—	Yes
Safe Stop with Door Monitoring	Slave - Safe Stop	Yes	—	Yes
Safe Limited Speed	Slave - Safe Stop	Yes	—	Yes
	Slave - Safe Limited Speed	Yes	Yes	Yes
Safe Limited Speed with Door Monitoring	Slave - Safe Stop	Yes	—	Yes
	Slave - Safe Limited Speed	Yes	Yes	Yes
Safe Limited Speed with Enabling Switch Monitoring	Slave - Safe Stop	Yes	—	Yes
	Slave - Safe Limited Speed	Yes	Yes	Yes
Safe Limited Speed with Door Monitoring and Enabling Switch Monitoring	Slave - Safe Stop	Yes	—	Yes
	Slave - Safe Limited Speed	Yes	Yes	Yes
Safe Limited Speed Status Only	Slave - Safe Stop	Yes	—	Yes
	Slave - Safe Limited Speed Status Only	Yes	Yes	—

(1) P20 [Cascaded Config] parameter equals Cascaded Middle Unit (Multi Mid).

(2) DC_Out to DM_In connections are required only for systems implementing door control or systems monitoring cascaded stopped status.

This table shows the supported Safety modes for slave safety options ($n+1$) cascaded from slaves (n).

Supported Safety Mode Combinations		Cascaded Connections Allowed		
Slave Safety Option (n)	Slave Safety Option ($n+1$)	SS_Out to SS_In	SLS_Out to SLS_In	DC_Out to DM_In ⁽¹⁾
Slave - Safe Stop	Slave - Safe Stop	Yes	—	Yes
Slave - Safe Limited Speed	Slave - Safe Stop	Yes	—	Yes
	Slave - Safe Limited Speed	Yes	Yes	Yes
Slave - Safe Limited Speed Status Only	Slave - Safe Stop	Yes	—	Yes
	Slave - Safe Limited Speed Status Only	Yes	Yes	Yes

(1) DC_Out to DM_In connections are required only for systems implementing door control.

Notes:

Safe Maximum Speed and Direction Monitoring

efesotomasyon.com

Introduction

This chapter describes Safe Maximum Speed (SMS), Safe Maximum Acceleration (SMA), and Safe Direction (SDM) monitoring modes of safety operation and provides a list of configuration parameters.

Topic	Page
Safe Maximum Speed (SMS) Monitoring	113
Safe Maximum Acceleration (SMA) Monitoring	116
Safe Direction Monitoring (SDM)	118
Max Speed, Max Accel, and Direction Monitoring Parameter List	120

Safe Maximum Speed (SMS) Monitoring

Configure Safe Maximum Speed monitoring by setting the P61 [Max Speed Enable] parameter to Enable. When configured, Safe Maximum Speed monitoring is active any time the safety option configuration is valid and the Safety mode is not Disabled.

When you configure the safety option for Safe Maximum Speed, the feedback velocity is monitored and compared against a user-configurable limit.

The P62 [Safe Max Speed] parameter is relative to encoder 1. If the monitored speed is greater than or equal to the configured P62 [Safe Max Speed] value, an SMS Speed fault (Stop Category fault) occurs.

Figure 37 - Safe Max Speed Timing Diagram

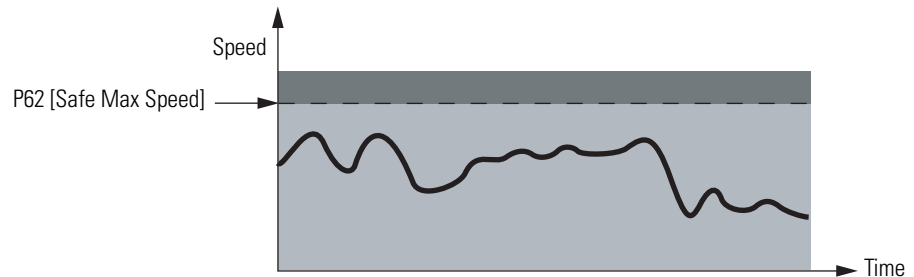

You define the Safe Stop Type initiated by the safety option in the event of an SMS Speed fault by using the P63 [Max Spd Stop Typ] parameter.

P63 [Max Spd Stop Typ] Parameter	Description
0 = Use Safe Torque Off with Check for Standstill (Torque Off)	The safety option initiates Safe Torque Off with Check for Standstill any time an SMS Speed fault is detected while the safety option is monitoring motion.
1 = Use Configured Stop Type (Safe Stp Typ)	The safety option initiates the configured P45 [Safe Stop Type] parameter any time an SMS Speed fault is detected while the safety option is monitoring motion.

If an SMS Speed fault is detected during a Stop Monitoring Delay, P46 [Stop Mon Delay], the delay ends immediately and the configured Stop Delay P47 [Max Stop Time] begins.

Figure 38 - SMS Speed Fault During Stop Monitoring Delay

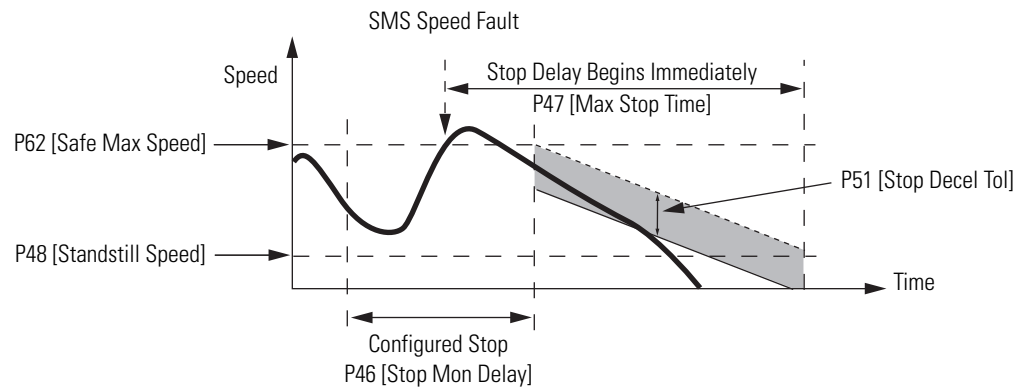

If an SMS Speed fault is detected during the Stop Delay [Max Stop Time], and the P63 [Max Spd Stop Typ] parameter equals Use Configured Stop Type (Safe Stp Typ), and the feedback signals indicate less than maximum frequency⁽¹⁾ for your encoder type, the fault is reported, but no further action is taken. Deceleration monitoring performs the safety function during the Stop Delay P47 [Max Stop Time]. That is, if an SMS Speed fault occurs during the Stop Delay P47 [Max Stop Time], the fault is ignored and the stopping action continues.

(1) 100 kHz for Sin/Cos or 200 kHz for Incremental

Figure 39 - SMS Speed Fault When P63 [Max Spd Stop Typ] Set to 'Use Configured Stop Type (Safe Stp Typ)'

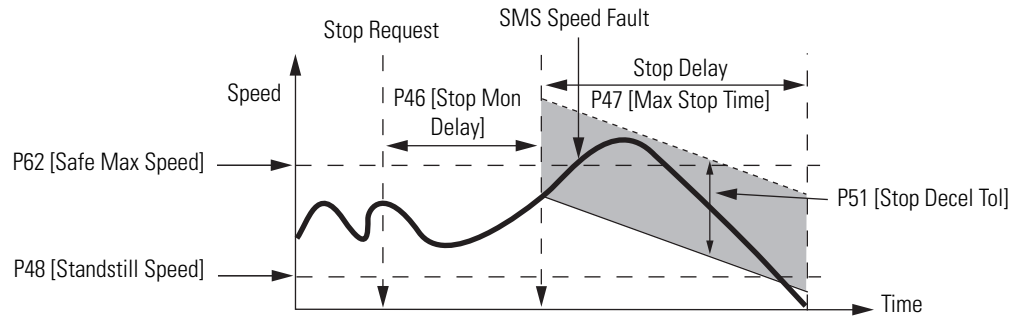

If an SMS Speed fault is detected during the Stop Delay P47 [Max Stop Time] and the P63 [Max Spd Stop Typ] parameter equals Use Safe Torque Off with Check for Standstill (Torque Off), the SMS Speed fault is reported and motion power is removed. The Stop Delay P47 [Max Stop Time] continues with standstill checking enabled.

Figure 40 - SMS Speed Fault When P63 [Max Spd Stop Typ] Set to 'Use Safe Torque Off with Check for Standstill (Torque OFF)'

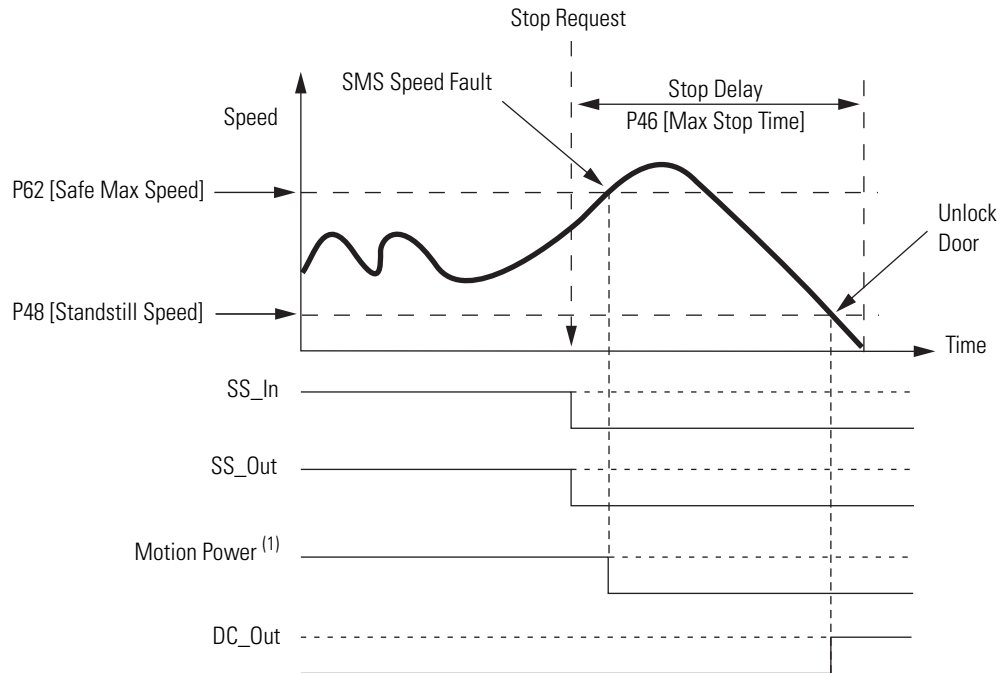

(1) This signal is internal, between the safety option and drive.

For more information about faults, see Fault Reactions on [page 155](#).

Safe Maximum Acceleration (SMA) Monitoring

Configure Safe Maximum Acceleration monitoring by setting the P64 [Max Accel Enable] parameter to Enable. When configured, Safe Maximum Acceleration Monitoring is active any time the safety option configuration is valid and Safety mode is not set to Disabled.

The resolution accuracy of the acceleration monitoring in revolutions/second² is equal to the speed resolution in:

$$\frac{(RPM \times 2) \div 60}{[(OverSpd Response - 36)/1000] \text{ seconds}}$$

The resolution accuracy of the acceleration monitoring in mm/second² is equal to the speed resolution in:

$$\frac{(mm/s \times 2)}{[(OverSpd Response - 36)/1000] \text{ seconds}}$$

IMPORTANT Acceleration is measured within the Overspeed Response Time, P24 [OvrSpd Response] parameter.

When you configure the safety option for Safe Maximum Acceleration, the safety option monitors the acceleration rate and compares it to a configured Safe Maximum Acceleration Limit, P65 [Safe Accel Limit]. If the acceleration is greater than or equal to the configured P65 [Safe Accel Limit], an Acceleration fault (Stop Category fault) occurs.

Figure 41 - Acceleration Timing Diagram

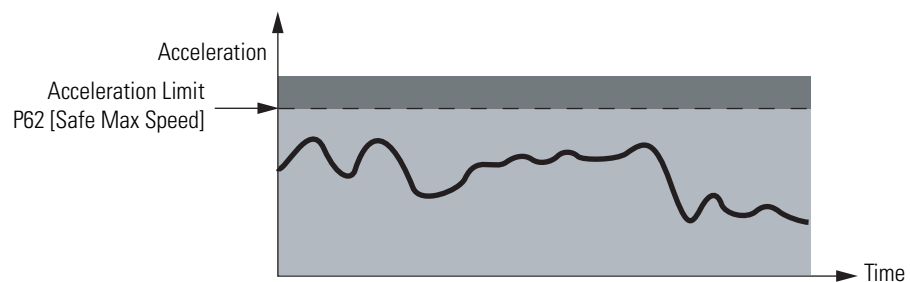

You define the Safe Stop Type initiated by the safety option in the event of an Acceleration fault by using the P66 [Max Acc Stop Typ] parameter.

P66 [Max Acc Stop Typ] Parameter	Description
0 = Use Safe Torque Off with Check for Standstill (Torque Off)	The safety option initiates Safe Torque Off with Check for Standstill any time an Acceleration fault is detected while the safety option is monitoring motion.
1 = Use Configured Stop Type (Safe Stp Typ)	The safety option initiates the configured Safe Stop Type any time an Acceleration fault is detected while the safety option is monitoring motion.

If an Acceleration fault is detected during a Stop Monitoring Delay P46 [Stop Mon Delay] and the P66 [Max Acc Stop Typ] parameter is configured as Use Safe Torque Off with Check for Standstill (Torque Off), the Stop Monitoring Delay P46 [Stop Mon Delay] ends immediately and Stop Delay P47 [Max Stop Time] begins.

If an Acceleration fault is detected during the Stop Delay P47 [Max Stop Time], and the P66 [Max Acc Stop Typ] parameter equals Use Configured Stop Type (Safe Stp Typ), and feedback signals indicate less than the maximum frequency⁽¹⁾ for your encoder type, then the fault occurs with no further action. Deceleration Monitoring performs the safety function during the Stop Delay P47 [Max Stop Time]. That is, if an Acceleration fault occurs during the Stop Delay P47 [Max Stop Time], the fault is ignored and the stopping action continues.

Figure 42 - Acceleration Fault When P66 [Max Acc Stop Typ] Set to 'Use Configured Stop Type (Safe Stp Typ)'

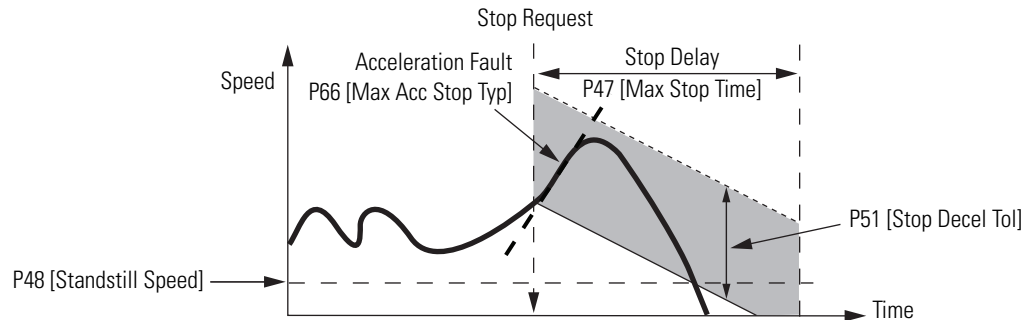

If an Acceleration fault is detected during the Stop Delay P47 [Max Stop Time] and the P66 [Max Acc Stop Typ] parameter equals Use Safe Torque Off with Check for Standstill (Torque Off), the Acceleration fault is reported and Motion Power is removed. The Stop Delay P47 [Max Stop Time] continues with standstill checking enabled.

(1) 100 kHz for Sin/Cos or 200 kHz for Incremental

Figure 43 - Acceleration Fault When P66 [Max Acc Stop Typ] Set to 'Use Safe Torque Off with Check for Standstill (Torque OFF)'

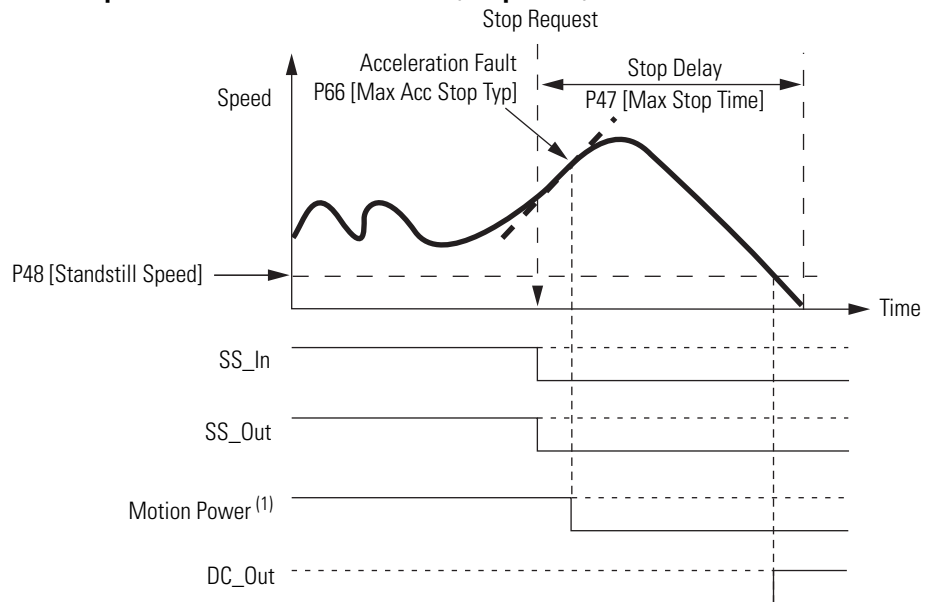

(1) This signal is internal, between the safety option and drive.

For more information about faults, see Fault Reactions on [page 155](#).

Safe Direction Monitoring (SDM)

When configured for Safe Direction Monitoring, the safety option monitors the feedback direction and initiates the configured Safe Stop Type when motion in the illegal direction is detected. You configure Safe Direction Monitoring by using the P42 [Direction Mon] parameter. This parameter also determines the direction, positive or negative, in which motion is allowed.

Table 16 - Enable Safe Direction Monitoring

P42 [Direction Mon] Parameter	Description
0 = Disabled	Safe Direction Monitoring is disabled.
1 = Positive Always	Safe Direction Monitoring is active any time the configuration is valid and not Disabled.
2 = Negative Always	
3 = Positive During SLS	Safe Direction Monitoring is performed only when the safety option is actively monitoring Safe Limited Speed.
4 = Negative During SLS	

IMPORTANT Be sure to set the P30 [Fbk 1 Polarity] and P35 [Fbk 2 Polarity] configuration parameters properly for a consistent direction between encoder 1 and encoder 2.

You may configure a position limit, in encoder units, tolerated in the wrong direction before a Direction fault occurs, by using the P43 [Direction Tol] parameter.

Figure 44 - Positive Safe Direction Monitoring Timing Diagram

P42 [Direction Mon] = 1 “Pos Always”

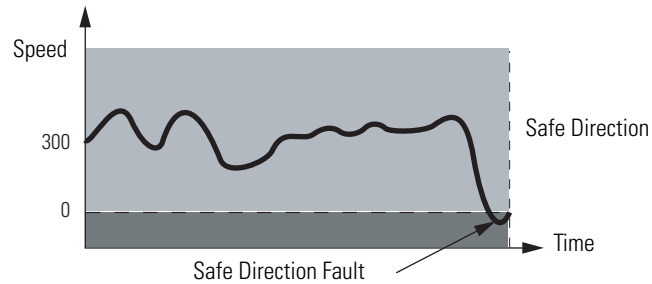
**Figure 45 - Negative Safe Direction Monitoring Timing Diagram**

P42 [Direction Mon] = 2 “Neg Always”

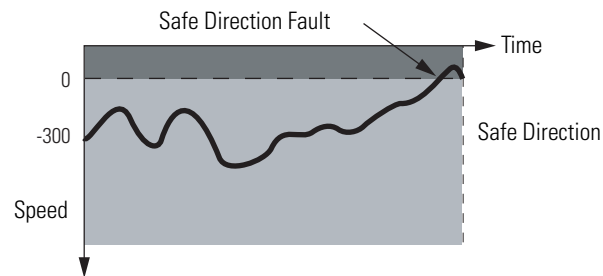

If motion is detected in the incorrect direction while Safe Direction Monitoring is active, a Direction fault occurs. If a Direction fault is detected while the safety option is monitoring motion, the configured P45 [Safe Stop Type] is initiated and direction monitoring is not performed during the safe stop. If a Direction fault is first detected after the initiation of the safe stop, then all outputs go to their faulted state.

For more information about faults, see Fault Reactions on [page 155](#).

Max Speed, Max Accel, and Direction Monitoring Parameter List

Set these parameters to configure Safe Maximum Speed, Safe Maximum Acceleration, and Safe Direction Monitoring.

File	Group	No.	Display Name Full Name Description	Values		Read-Write	Data Type	
HOST GROUPS	Feedback	30	Fbk 1 Polarity Feedback 1 Polarity Defines the direction polarity for encoder 1.	Default: 0 = "Normal" Options: 0 = "Normal" (Same as encoder) 1 = "Reversed"		RW	Real	
		35	Fbk 2 Polarity Feedback 2 Polarity Defines the direction polarity for encoder 2.	Default: 0 = "Normal" Options: 0 = "Normal" (Same as encoder) 1 = "Reversed"		RW	Real	
	Feedback	42	Direction Mon Direction Monitoring Defines the allowable direction if Safe Direction Monitoring is enabled. "Pos Always" (1) – Positive always "Neg Always" (2) – Negative always "Pos in SLS" (3) – Positive during safe limited speed monitoring "Neg in SLS" (4) – Negative during safe limited speed monitoring	Default: 0 = "Disabled" Options: 0 = "Disabled" 1 = "Pos Always" 2 = "Neg Always" 3 = "Pos in SLS" 4 = "Neg in SLS"		RW	Real	
		43	Direction Tol Direction Tolerance The position limit in encoder units tolerated in the wrong direction when Safe Direction Monitoring is active. Units are based on rotary or linear configuration defined by P29 [Fbk 1 Units].	Units: Deg mm Default: 10 Min/Max: 0 / 65,535 deg 0 / 65,535 mm		RW	Real	
	Max Speed		61	Max Speed Enable Maximum Speed Enable Enable Safe Maximum Speed Monitoring.	Default: 0 = "Disable" Options: 0 = "Disable" 1 = "Enable"		RW	Real
			62	Safe Max Speed Safe Maximum Speed Defines the maximum speed limit that will be tolerated if Safe Maximum Speed monitoring is enabled.	Units: RPM mm/s Default: 0 Min/Max: 0 / 65,535 RPM 0 / 65,535 mm/s		RW	Real
			63	Max Spd Stop Typ Maximum Speed Stop Type Defines the safe stop type that will be initiated in the event of a SMS Speed Fault. "Torque Off" (0) – Safe Torque Off With Standstill Checking "Safe Stp Typ" (1) – Safe Torque Off Without Standstill Checking	Default: 0 = "Torque Off" Options: 0 = "Torque Off" 1 = "Safe Stp Typ"		RW	Real
			64	Max Accel Enable Maximum Acceleration Enable Enable Safe Maximum Acceleration Monitoring.	Default: 0 = "Disable" Options: 0 = "Disable" 1 = "Enable"		RW	Real
			65	Safe Accel Limit Safe Acceleration Limit Defines the Safe Maximum Acceleration Limit, relative to encoder 1, for which the system is being monitored. Units are based on rotary or linear configuration defined by P29 [Fbk 1 Units].	Units: Rev/s ² mm/s ² Default: 0 Min/Max: 0 / 65,535 rev/s ² 0 / 65,535 mm/s ²		RW	Real
			66	Max Acc Stop Typ Maximum Acceleration Stop Type Defines the safe stop type that will be initiated in the event of an Acceleration Fault. "Torque Off" (0) – Safe Torque Off With Standstill Checking "Safe Stp Typ" (1) – Safe Torque Off Without Standstill Checking	Default: 0 = "Torque Off" Options: 0 = "Torque Off" 1 = "Safe Stp Typ"		RW	Real

Safety Configuration and Verification

efesotomasyon.com

Introduction

This chapter provides guidelines for configuring your safe speed monitor option module.

Topic	Page
Safety Configuration	121
Basics of Application Development and Testing	123
Commissioning the System	124
Editing the Configuration	128

Safety Configuration

When you configure a speed monitoring safety system, you must record and verify the configuration signature and set the safety-lock status of the system configuration. Though optional, you can configure a password to help protect the system configuration from unauthorized modifications.

Configuration Signature ID

The configuration Signature ID is an identification number that uniquely identifies a specific configuration for a safety option. Each time the system is configured or reconfigured, a new configuration signature is generated to identify that specific configuration.

You can view the configuration Signature ID by accessing the P10 [Signature ID] parameter.

Safety-lock

When you have verified the operation of the system and recorded the configuration Signature ID, you must lock the configuration to protect it from modification.

IMPORTANT If you do not safety-lock the configuration, untested or unintentional changes can be made to the safety option configuration, which could result in unexpected system behavior.

You can lock the configuration by using the P5 [Lock State] parameter.

You can check the safety-lock status of the system by viewing the Configuration Lock bit (bit 1) in the P68 [Guard Status] parameter. If the bit equals 1, the configuration is locked. If it equals 0, the configuration is unlocked.

Set and Change a Password

You can protect the system configuration by using an optional password. If you set a password, edits to the configuration, as well as safety-locking and safety option reset operations require the password to be entered. You can set a password when the safety option is not safety-locked and the P6 [Operating Mode] parameter value equals 0 (Program).

Follow these steps to set a new password.

1. If you previously configured a password, enter the password by using the P1 [Password] parameter.
2. Enter the new password by using the P13 [New Password] parameter.
3. Set the P17 [Password Command] parameter to 1, which equals Change Password.

File	Group	No.	Display Name Full Name Description	Values		Read-Write	Data Type
				Default:	Min/Max:		
HOST GROUPS	Security	1	Password Password Password for Lock and Unlock function.	Default: N/A Min/Max: 0 / 4,294,967,295		RO	Real
		13	New Password New Password 32-bit configuration password.	Default: N/A Min/Max: 0 / 4,294,967,295		RW	Real
		17	Password Command Password Command Save new password command.	Default: 0 = "No action" Options: 0 = "No action" 1 = "Change PW" (Change Password) 2 = "Reset PW" (Reset Password)		RW	Real

Resetting the Password

If you forget the password and need to reset it, follow these steps.

1. Read the contents of the P18 [Security Code] parameter.
2. Contact Rockwell Automation Technical Support (440-646-5800) and provide the Security Code value and the serial number of the safety option. A technical support representative will use the security code to calculate a Vendor Password value.
3. Enter the value provided by your Rockwell Automation Technical Support representative into the P19 [Vendor Password] parameter.

4. Set the P17 [Password Command] parameter to 2, which equals Reset Password.
5. Enter the new password by using the P13 [New Password] parameter.
6. Set the P17 [Password Command] parameter to 1, which equals Change Password.

Resetting the Configuration

When the safety option is unlocked and the P6 [Operating Mode] parameter equals 0 (Program), you can reset the safety option's configuration parameters to their factory default settings, by setting the P7 [Reset Defaults] parameter to 1. The reset parameters are sent to the safety option when the P6 [Operating Mode] parameter is changed to 1 (Run).

Basics of Application Development and Testing

Configuration for the intended SIL CL3, PL_e, or Cat 4 system should be carried out by the system integrator or an operator trained and experienced in safety applications. The developer must follow good design practices.

- Use functional specifications, including flow charts, timing diagrams and sequence charts.
- Perform a configuration review.
- Perform configuration validation.

Commissioning the System

The flowchart shows the steps required for commissioning a Speed Monitoring safety system. The items in bold are explained in the following sections.

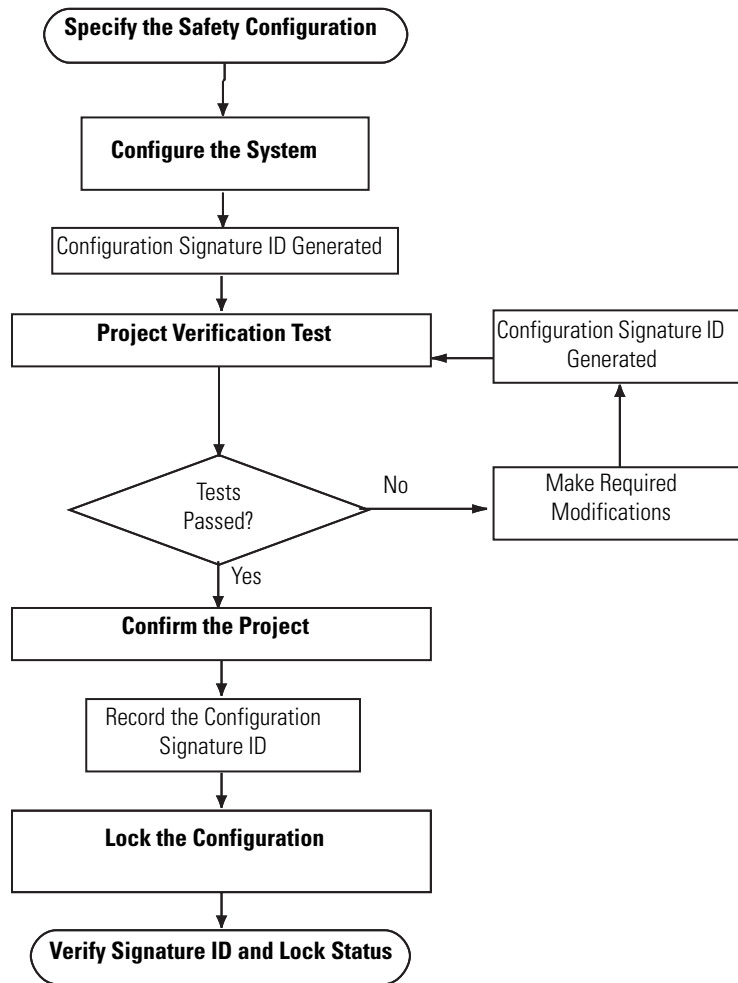

Specifying the Safety Configuration

You must create a specification for the system configuration that addresses the safety requirements identified by a risk assessment of your application. Use the specification to verify that the configuration is selected correctly and that it fully addresses your application's functional and safety control requirements. The specification must be a detailed description that may include (if applicable):

- a sequence of operations.
- flow and timing diagrams.
- sequence charts.
- a configuration description of each parameter.
- documented descriptions of the steps with step conditions and actuators to be controlled.
- input and output definitions.
- I/O wiring diagrams and references.
- a theory of operation.
- a matrix or table of stepped conditions and the actuators to be controlled, including sequence and timing diagrams.
- a definition of marginal conditions, for example, operating modes.

The I/O portion of the specification must contain the analysis of field circuits, that is, the type of sensors and actuators.

- Sensors (Digital or Analog)
 - Signal in standard operation (dormant current principle for digital sensors, sensors OFF means no signal)
 - Determination of redundancies required for SIL levels
 - Discrepancy monitoring and visualization, including your diagnostic logic
- Actuators
 - Position and activation in standard operation (normally OFF)
 - Safe reaction/positioning when switching OFF or power failure.
 - Discrepancy monitoring and visualization, including your diagnostic logic.

Configure the Safe Speed Monitor Option Module

You configure the safety option by using a HIM to set the configuration parameters. You can also use DriveExplorer or DriveExecutive software.

Drive	DriveExplorer	DriveExecutive
PowerFlex 753	Version 6.03 or later	Version 5.03 or later
PowerFlex 755	Version 6.01 or later	Version 5.01 or later

The safety option is configured in the Safe State. The safety option must be unlocked to be configured. If a password exists, you must provide the password to unlock the safety option.

Follow these steps to configure the safety option.

1. If the safety option configuration is locked, you can unlock the configuration by setting the P5 [Lock State] parameter to 1 (Unlock).
If an error occurs, you need to enter the password, by using the P1 [Password] parameter.
2. Place the safety option in Program mode by setting the P6 [Operating Mode] parameter to 0.
If you are using DriveExplorer or DriveExecutive software, you will see the P10 [Signature ID] parameter value change to 0.

IMPORTANT When the safety option is in Program mode, the P69 [IO Diag Status] parameter is not updated or refreshed.

3. Edit parameters to meet your system configuration specification and risk assessment requirements.
4. When you are finished editing parameters, set the P6 [Operating Mode] parameter to 1, which puts the safety option into Run mode.
A configuration Signature ID is generated.
5. Record the configuration Signature ID from the contents of the P10 [Signature ID] parameter.
6. Enter the password, if required.
7. Set the P5 [Lock State] parameter to 1 (Lock).

Refer to [Appendix B](#) for a complete list of parameters and settings for the safety option.

Project Verification Test

To check that the safety option's configuration adheres to the application specification, you must generate a suitable set of test cases covering the application. The set of test cases must be filed and retained as the test specification. You must include a set of tests to prove the validity of the safety configuration parameters.

You must perform a complete functional test of the entire system before the operational startup of a safety-related system.

Confirm the Project

You must check each parameter to make sure it is set to the correct value according to your system configuration specification.

Safety Validation

An independent, third-party review of the safety system may be required before the system is approved for operation. An independent, third-party certification is required for IEC 61508 SIL CL3.

Verifying the Signature and Lock in the Safe Speed Monitor Option Module

To meet SIL CL3, PLe, or Cat 4 requirements, you must verify that the correct configuration is locked in the safety option.

To verify the configuration Signature ID, view the contents of the P10 [Signature ID] parameter and make sure that it matches the configuration Signature ID you recorded as part of the configuration process on [page 126](#).

To verify the lock status, you can view the P5 [Lock State] parameter. You can also view the status of the Configuration Lock bit (bit 1) of the P68 [Guard Status] parameter. If the bit equals 1, the configuration is locked. If the bit equals 0, the configuration is unlocked.

Editing the Configuration

Only authorized, specially-trained personnel can make edits to the configuration. These personnel should use all supervisory methods available, for example, using the software password protections.

When authorized, specially-trained personnel make edits, they assume the central safety responsibility while the changes are in progress. These personnel must also maintain safe application operation.

You must sufficiently document all edits, including:

- authorization.
- impact analysis.
- execution.
- test information.
- revision information.

This flowchart shows the steps necessary to edit the safety option's configuration.

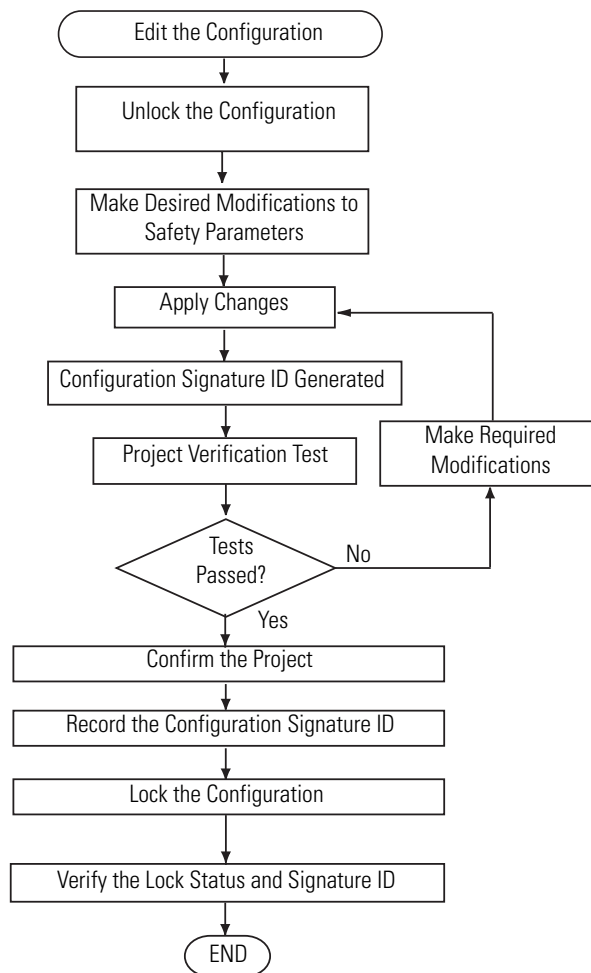

Configuration Examples

Introduction

These examples guide you through the basic steps required to program an application that uses some of the safety option functions. The remaining chapters of this manual provide detailed information on the operation of each safety function.

Topic	Page
Example Application 1	129
Example Application 2	139

As an alternative to using the steps listed in this chapter, the safety option can also be configured by using the Safe Speed Monitor Startup Wizard that is available in these software applications. Use of the wizard is recommended.

- DriveExplorer software, version 6.01 or later
- DriveExecutive software, version 5.01 or later
- RSLogix 5000 software, version 16.01 or later.

TIP Drives AOP (version 2.01 or later) must be installed to enable support for this wizard in RSLogix 5000 software.

Example Application 1

This example application uses the following basic configuration in a single-axis system.

- Safe Stop (SS) enabled with an E-stop button.
- Safe Limited Speed (SLS) initiated with a 2NC contact switch.
- Door Monitoring (DM) of a guardlocking switch (TLS-3 GD2) configured as Power to Release.
- A Reset button with 1 NO contact.
- One encoder connected with Sin/Cos output signal and resolution of 1024.
- A configured Safe Maximum Speed (SMS) limit.

Each of the following sections describes the settings you need to enter for each parameter group. You can use a HIM, or DriveExplorer or DriveExecutive software to configure the safety option.

Example 1: Initial Security Group Settings

Figure 46 - Security Group Parameters

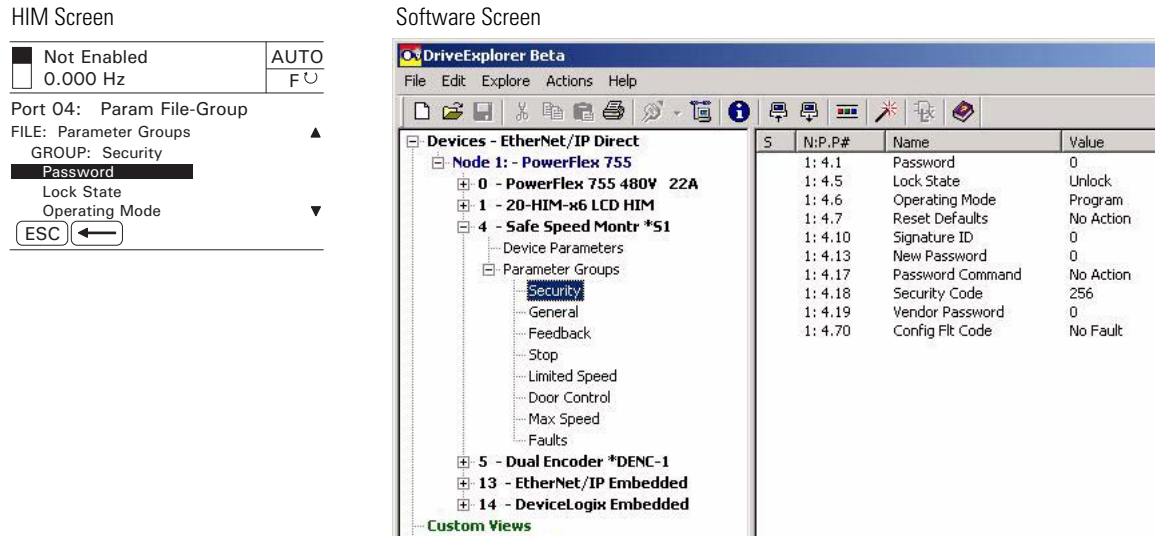

Follow these steps to put the safety option into Program mode for configuration.

1. From the Security group, choose the P5 [Lock State] parameter.
The default value of the Lock State parameter is 0 or unlocked.
2. If the safety option is locked (Lock State parameter value equals 1), set the P5 [Lock State] parameter value to 0.
If an error occurs, a password has been configured to protect the safety option configuration.
3. Choose the P1 [Password] parameter.
4. Type the password.
5. Choose the P6 [Operating Mode] parameter.
The default value is 0, which equals Program.
6. If the safety option is in Run mode (Operating Mode parameter equals 1), set the P6 [Operating Mode] parameter to 0 to enable you to enter a new configuration.
7. If you want to configure a password or change the password, choose the P13 [New Password] parameter.
The default value is 0. Enter a value from 0...4,294,967,295.
8. Type the new password value.
9. Choose the P17 [Password Command] parameter.
10. Set the P17 [Password Command] parameter value to 1, which equals Change Password (Change PW).

- Go to the next section to set the parameters found in the General parameters group.

Example 1: General Group Settings

Figure 47 - General Group Parameters

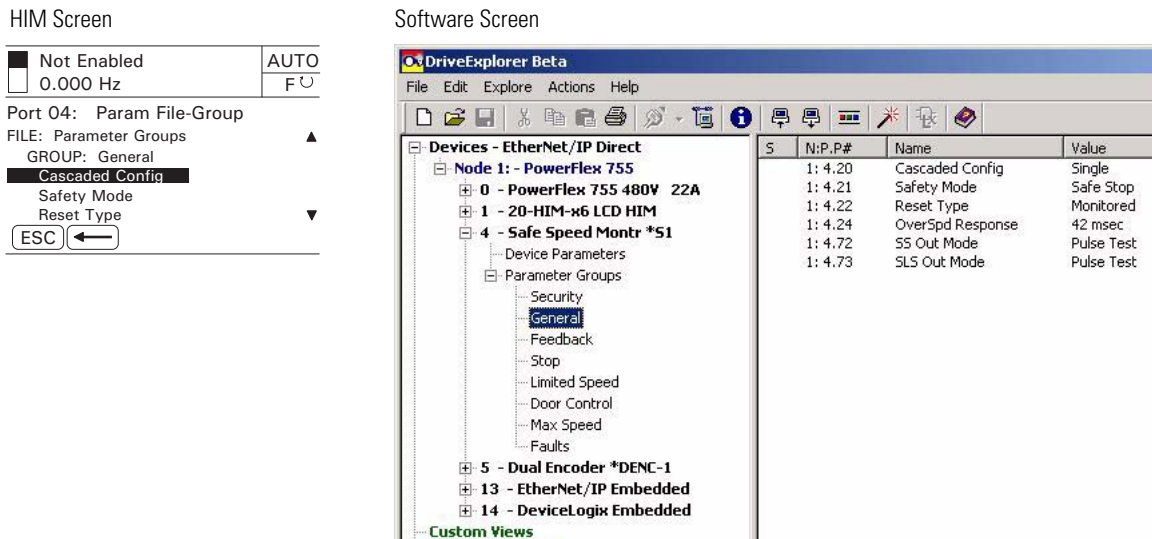

Follow these steps to configure the general operation of the safety option.

- From the General group, choose the P20 [Cascaded Config] parameter.
- Set the P20 [Cascaded Config] parameter to 0 (default) to configure the safety option as a Single unit.
- Choose the P21 [Safety Mode] parameter.
The default setting is 1, which equals Safe Stop.
- Set the P21 [Safety Mode] parameter value to 4 for Master, Safe Limited Speed with Door Monitoring mode (Lim Speed DM).

In this mode, the door is locked when the machine speed is above a configured Safe Speed Limit. The door can be unlocked when the machine is at Standstill Speed or is at or below the Safe Speed Limit **and** the SLS_In input is off.

- Choose the P22 [Reset Type] parameter.
- Set the P22 [Reset Type] parameter value to 2 (default), which equals Manual Monitored (Monitored).

The Manual Monitored setting requires a closing and opening of the reset circuit for a reset.

- Choose the P24 [OverSpd Response] parameter.
The default Overspeed Response time is 42 ms.

8. Set the P24 [OverSpd Response] parameter value to 1, which equals 48 ms. See [Overspeed Response Time](#) on page 49 for details.
9. Go to the next section to configure the type of feedback by using the Feedback parameters group.

Example 1: Feedback Group Settings

Figure 48 - Feedback Group Parameters

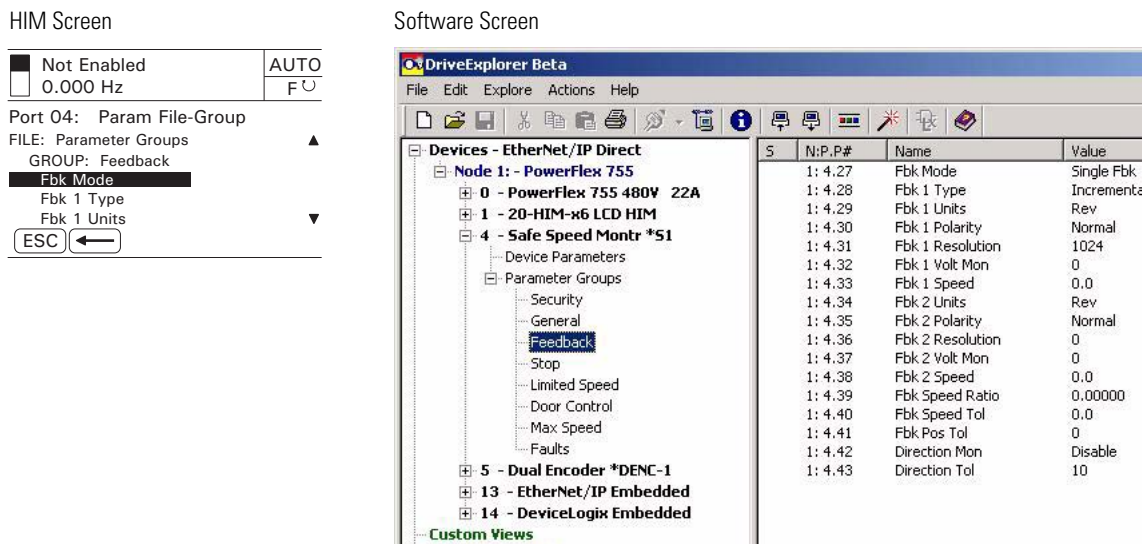

Follow these steps to configure the type of feedback used by the safety option.

1. From the Feedback group, choose the P27 [Fbk Mode] parameter.
2. Set the P27 [Fbk Mode] parameter value to 0 (default) for redundant processing and cross-checking of the single encoder input in a 1oo2 architecture.
3. Choose the P28 [Fbk 1 Type] parameter.
The default value is 1 for incremental encoder input.
4. Set the P28 [Fbk 1 Type] parameter value to 0 for Sine/Cosine and internal monitoring of the single encoder input.
5. Choose the P29 [Fbk 1 Units] parameter.
6. Set the P29 [Fbk 1 Units] parameter to 0 (default), which equals Rotary feedback.
7. Choose the P30 [Fbk 1 Polarity] parameter.
8. Set the P30 [Fbk 1 Polarity] parameter to 0 (default) to set up the direction for monitoring to be the same as the encoder direction (Normal).
9. Choose the P31 [Fbk 1 Resolution] parameter.

10. Choose 1024 (default) or enter value between 1...65,535 pulses/revolution based on the encoder's specifications.
11. Choose the P32 [Fbk 1 Volt Mon] parameter.
12. Enter 5, 9, or 12V to monitor voltage in accordance with the encoder's specifications, or enter 0 (default) to disable encoder voltage monitoring.

TIP The P33 [Fbk 1 Speed] parameter displays the output speed of the encoder as a value between -214,748,364.8...214,748,364.8 rpm based on the encoder's configuration. You do not need to enter a setting or value for this parameter.

13. Choose the P42 [Direction Mon] parameter.
14. Set the P42 [Direction Mon] parameter value to 0 (default), which equals Disabled.

You may disable Safe Direction Monitoring if only one direction of rotation is possible or there is no safety-related restriction on the direction of rotation.

15. Go to the next section to set the parameters found in the Stop parameters group.

Example 1: Stop Group Settings

Figure 49 - Stop Group Parameters

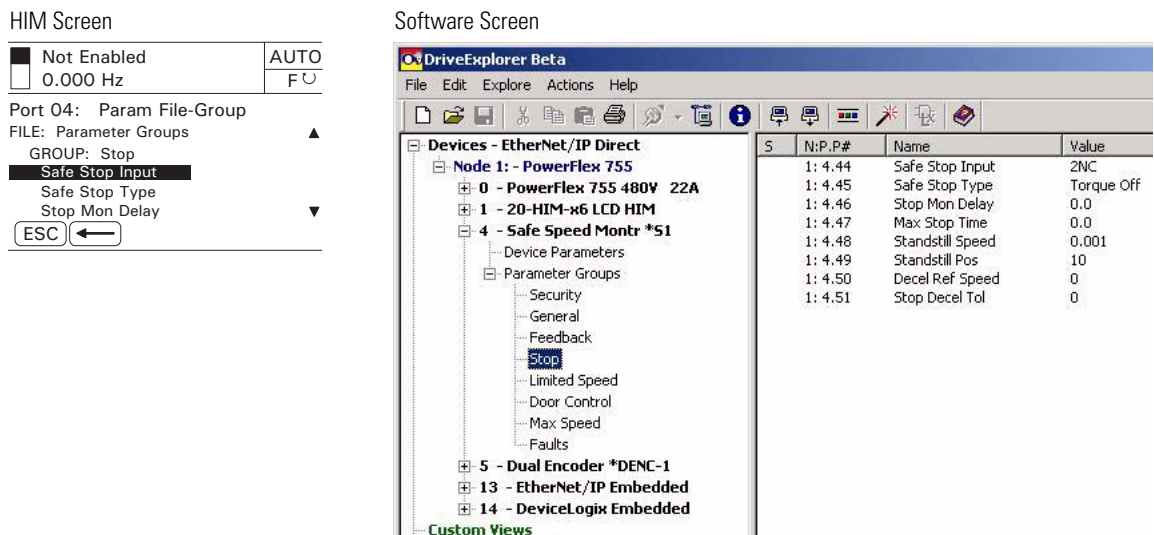

Follow these steps to configure the Stop operation of the safety option.

1. From the Stop group, choose the P44 [Safe Stop Input] parameter.
2. Set the P44 [Safe Stop Input] parameter value to 1 (default) for 2NC (dual-channel equivalent) operation.

In this example application, the Safe Stop input (SS_In) monitors an E-Stop button with two normally-closed (2NC) contacts.

3. Choose the P45 [Safe Stop Type] parameter.
4. Set the P45 [Safe Stop Type] parameter value to 0 (default), which equals Safe Torque Off with Standstill Speed Checking (Torque Off).

Safe Torque Off with Standstill Speed Checking (Torque Off) switches off motion power immediately after an E-Stop command and sets door control to Unlock when the Standstill Speed is detected.

5. Choose the P47 [Max Stop Time] parameter.

The default value is 10 s, but you can enter a value from 0...6553.5 s.

6. Type the value of the expected coast-to-stop time plus a reasonable tolerance after the Safe Stop command is initiated.

If the machine's speed is not below the Standstill Speed within the Stop Delay [Max Stop Time] period you entered, a Stop Speed Fault occurs and door control remains set to Lock until the Standstill Speed is reached.

7. Choose the P48 [Standstill Speed] parameter.

The default value is 0.001 rpm, but you can enter a value from 0.001...65,535 rpm. The Standstill Speed is measured in revolutions per minute, because the P29 [Fbk 1 Units] parameter is configured for Rotary feedback.

8. Enter a value in the P48 [Standstill Speed] parameter field to define the speed at which motion is stopped with no relative position change before the safety option determines standstill has been reached.

9. Choose the P49 [Standstill Pos] parameter.

The default value is 360 degrees, but you can enter a value from 0...65,535 degrees. The Standstill Position is measured in degrees because the P29 [Fbk 1 Units] parameter is configured for Rotary feedback.

10. Enter the value to define the position limit in encoder units that is tolerated after standstill has been reached.

11. Go to the next section to set the parameters found in the Limited Speed parameters group.

Example 1: Limited Speed Group Settings

Figure 50 - Limited Speed Group Parameters

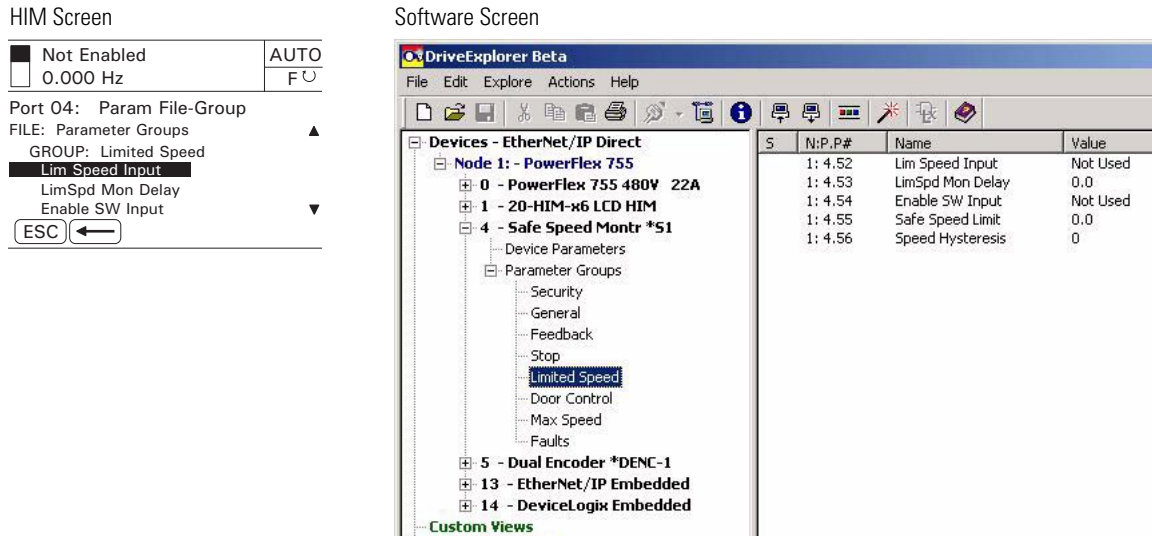

Follow these steps to configure the Safe Limited Speed operation.

1. From the Limited Speed group, choose the P52 [Lim Speed Input] parameter.

The default value is 0 (Disabled), for applications without Safe Limited Speed control.

2. Set the P52 [Lim Speed Input] parameter value to 1 for 2NC (dual-channel equivalent) operation.

In this example application, the Safe Limited Speed input (SLS_In) monitors a switch with two normally-closed (2NC) contacts. If the NC contacts are open and speed exceeds the configured Safe Limited Speed, the safety option initiates the configured Safe Stop Type.

When the safety option is actively monitoring Safe Limited Speed and the machine's speed is at or below the configured Safe Speed Limit, the gate interlock is released and the door can be opened.

3. Choose the P55 [Safe Speed Limit] parameter.

The default value is 0 rpm or mm/s. The valid range is from 0...6553.5.

4. Type the maximum allowable rpm value for safe (reduced) velocity.

The speed is calculated in rpm, based on the Fbk 1 Units parameter setting (0 = Rotary feedback) entered previously.

5. Go to the next section to set the parameters that configure Door Control operation.

Example 1: Door Control Group Settings

Figure 51 - Door Control Group Parameters

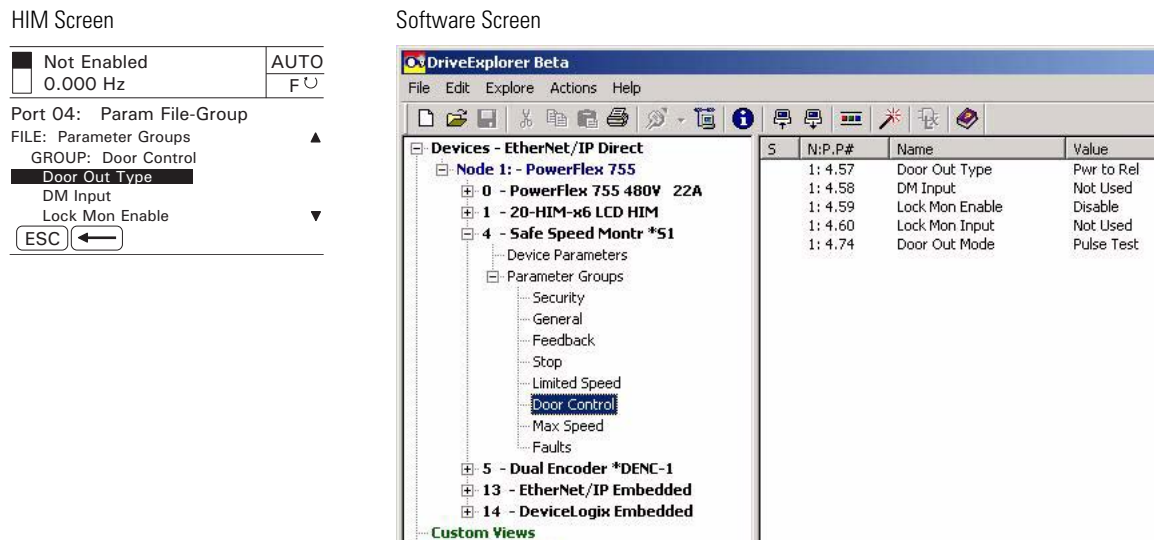

Follow these steps to configure Door Control operation for the safety option.

1. From the Door Control group, choose the P57 [Door Out Type] parameter.
2. Set the P57 [Door Out Type] parameter to 0 (default), which equals Power to Release (Pwr to Rel).

This setting was chosen because power must be applied to the solenoid inside the TLS-3 GD2 gate switch to release the gate interlock.

3. Choose the P58 [DM Input] parameter.
The default setting is 0 for applications that do not use an interlock switch.
4. Set the P58 [DM Input] parameter value to 1 for 2NC (dual-channel equivalent) operation.

In this example application, the DM Input (DM_In) monitors the TLS-3 GD2 switch, which has two normally-closed (2NC) safety contacts.

5. Choose the P59 [Lock Mon Enable] parameter.
The default value is 0 (Disabled) for applications without an interlock switch.
6. Set the P59 [Lock Mon Enable] parameter value to 1 (Enabled) because this application uses the TLS-3 GD2 interlock switch.
7. Choose the P60 [Lock Mon Input] parameter.
The default value is 0 (Not Used) for applications that do not use an interlock switch.
8. Set the P60 [Lock Mon Input] parameter value to 1 for 2NC (dual-channel equivalent) operation.

In this example application, the Lock Monitor Input (LM_In) monitors the TLS-3 GD2 switch, which has two normally-closed (2NC) interlock monitoring contacts.

- Go to the next section to set the parameters that configure Safe Maximum Speed monitoring.

Example 1: Max Speed Group

Figure 52 - Max Speed Group Parameters

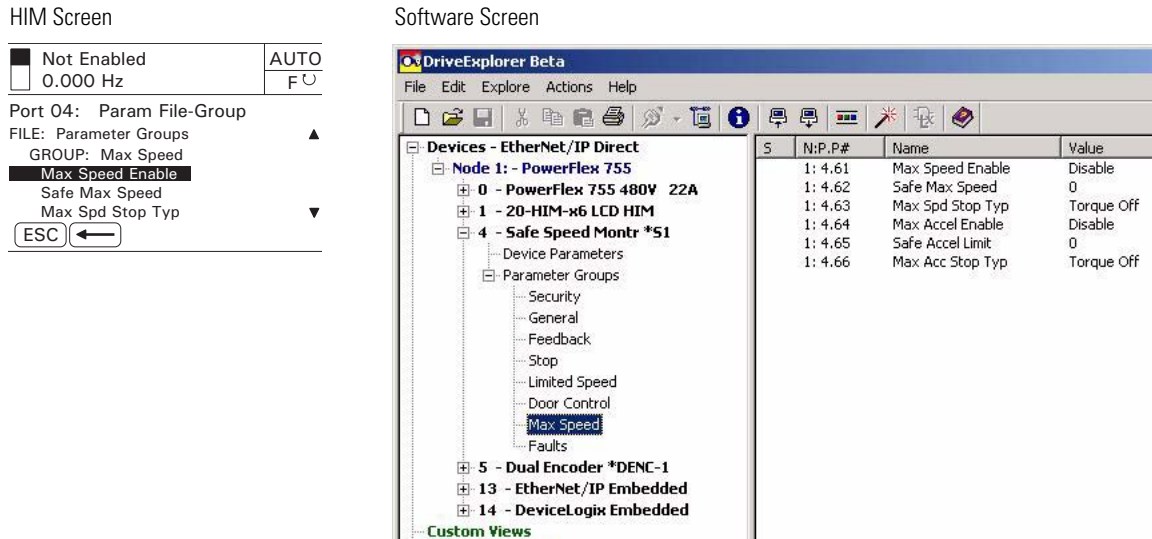

Follow these steps to configure Maximum Speed monitoring for the safety option.

- From the Max Speed group, choose the P61 [Max Speed Enable] parameter.

The default value is 0 (Disabled) for no maximum speed limitation.

- Set the P61 [Max Speed Enable] parameter value to 1 (Enabled), which monitors that the encoder feedback signal does not exceed the velocity configured by using the Safe Max Speed parameter.

- Choose the P62 [Safe Max Speed] parameter.

The default value is 0 rpm or mm/s. Enter a value from 0...6553.5.

- Type the maximum allowable rpm value for velocity.

The speed is calculated in rpm, based on the Fbk 1 Units parameter setting (0 = Rotary feedback) entered previously.

- Choose the P63 [Max Spd Stop Typ] parameter.

- Set the P63 [Max Spd Stop Typ] parameter value to 0 (default), which equals Use Safe Torque Off with Standstill Checking (Torque Off).

With this configuration, if speed exceeds the configured Safe Max Speed, the safety option initiates a Safe Torque Off with Standstill Checking type of Safe Stop, regardless of the configured Safe Stop Type.

7. Go on to the next section to put the safety option into Run mode and lock the configuration.

Example 1: Final Security Group Settings

This example includes only the steps for entering a configuration by using the HIM module or software program. You must also follow the requirements described in [Chapter 10](#), Safety Configuration and Verification.



ATTENTION: You must verify the configuration and validate the entire system, including a complete functional test, before the operational startup of any safety-related system.

Only authorized, specially-trained personnel, experienced in the commissioning and operation of safety-related systems may configure, test, and confirm the project.

Follow these steps to put the safety option into Run mode, generate a configuration signature, and lock the configuration.

1. From the Security group, choose the P6 [Operating Mode] parameter.
2. Set the P6 [Operating Mode] parameter value to 1, which equals Run mode.

A configuration signature is generated.

3. Choose the P10 [Signature ID] parameter and record the configuration signature value stored in this parameter.
4. If you configured a password, choose the P1 [Password] parameter and type the password.
5. Choose the P5 [Lock State] parameter.
6. Set the P5 [Lock State] parameter value to 1 (Lock) to lock the configuration.

Example Application 2

This example application shows how to change the default configuration settings to set up the safety option for an application with these basic parameters:

- Safe Stop (SS) enabled with an E-stop button.
- Safe Limited Speed (SLS) initiated with a 2NC contact switch.
- A configured Safe Maximum Speed (SMS) limit.
- Door Monitoring (DM)
- Door Control (DC) to control a guardlocking switch (TLS-3 GD2, Power to Release style).
- A Reset button with 1 NO contact.
- Enabling Switch (ESM) with 2NC contacts. Hold the switch in the middle position to access the machine for maintenance while it is running at Safe Limited Speed.
- One encoder connected with Sin/Cos output signal and resolution of 1024.

Each of the following sections describes the settings you need to enter for each parameter group. You can use a HIM, or DriveExplorer or DriveExecutive software to configure the safety option.

Example 2: Initial Security Group Settings

Figure 53 - Security Group Parameters

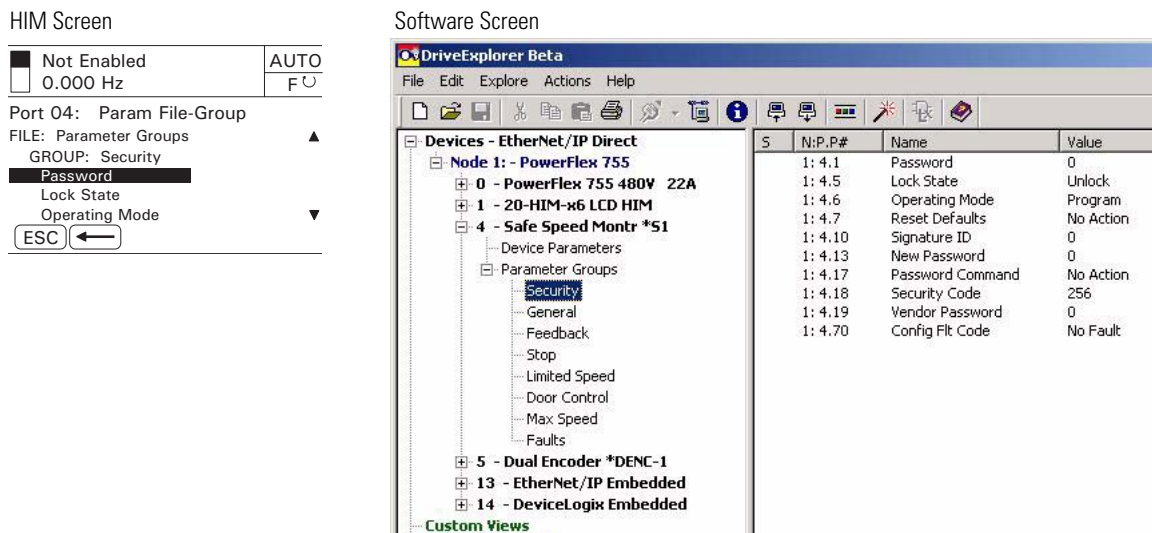

Follow these steps to put the safety option into Program mode for configuration.

1. From the Security group, choose the P5 [Lock State] parameter.
The default value of the Lock State parameter is 0 or unlocked.
2. If the safety option is locked (Lock State parameter value equals 1), set the P5 [Lock State] parameter value to 0.

If an error occurs, a password has been configured to protect the safety option configuration.

3. Choose the P1 [Password] parameter.
4. Type the password.
5. Choose the P6 [Operating Mode] parameter.
The default value is 0, which equals Program.
6. If the safety option is in Run mode (Operating Mode parameter equals 1), set the P6 [Operating Mode] parameter to 0 to enable you to enter a new configuration.
7. If you want to configure a password or change the password, choose the P13 [New Password] parameter.
The default value is 0. Enter a value from 0...4,294,967,295.
8. Type the new password value.
9. Choose the P17 [Password Command] parameter.
10. Set the P17 [Password Command] parameter value to 1, which equals Change Password (Change PW).
11. Go to the next section to set the parameters found in the General parameters group.

Example 2: General Group Settings

Figure 54 - General Group Parameters

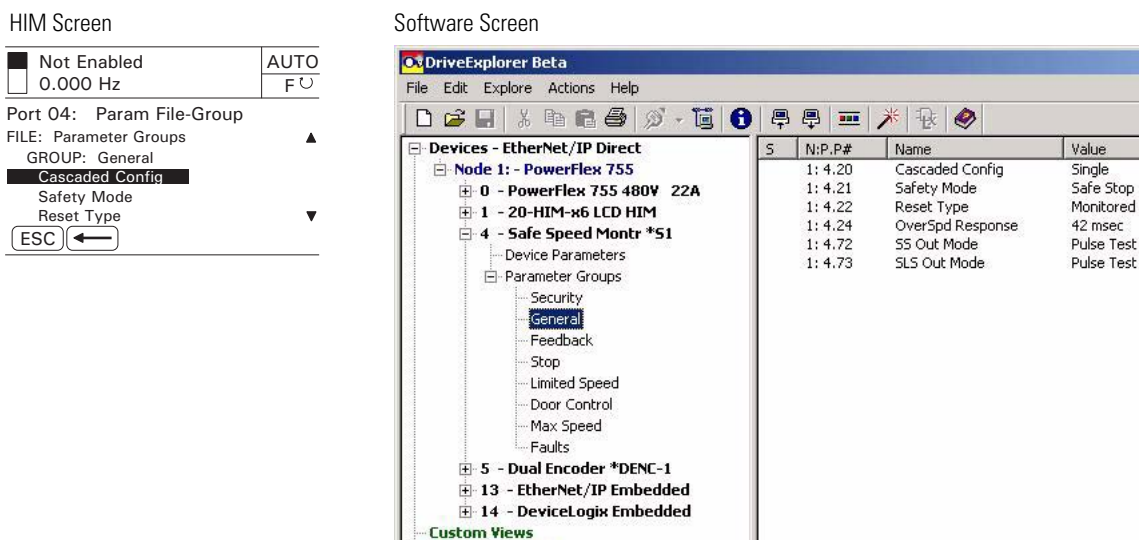

Follow these steps to configure the general operation of the safety option.

1. From the General group, choose the P20 [Cascaded Config] parameter.

2. Set the P20 [Cascaded Config] parameter to 0 (default) to configure the safety option as a Single unit.

3. Choose the P21 [Safety Mode] parameter.

The default setting is 1, which equals Safe Stop.

4. Set the P21 [Safety Mode] parameter value to 6 for Master, Safe Limited Speed with Door Monitoring and Enabling Switch Monitoring mode (Lim Speed DM ES).

In this mode, the door is locked when the machine speed is above a configured Safe Speed Limit. The door can be unlocked when a stop has been requested and the machine is at Standstill Speed. The door can also be unlocked when Safe Limited Speed monitoring (SLS_In input = OFF) and the speed is below the configured Safe Limited Speed. When the enabling switch is held in the middle position, the door can be opened while the machine is running below Safe Limited Speed.

5. Choose the P22 [Reset Type] parameter.

6. Set the P22 [Reset Type] parameter value to 2 (default), which equals Manual Monitored (Monitored).

The Manual Monitored setting requires an closing and opening of the reset circuit for a reset.

7. Choose the P24 [OverSpd Response] parameter.

The default Overspeed Response time is 42 ms.

8. Set the P24 [OverSpd Response] parameter value to 1, which equals 48 ms.

See Overspeed Response Time on page [49](#) for details.

9. Go to the next section to configure the type of feedback by using the Feedback parameters group.

Example 2: Feedback Group Settings

Figure 55 - Feedback Group Parameters

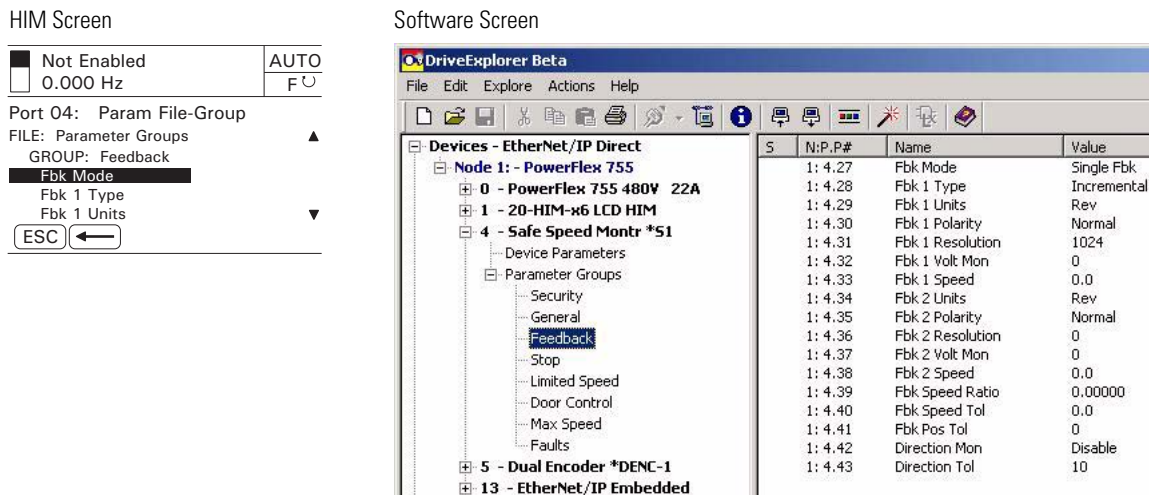

Follow these steps to configure the type of feedback used by the safety option.

1. From the Feedback group, choose the P27 [Fbk Mode] parameter.
2. Set the P27 [Fbk Mode] parameter value to 0 (default) for redundant processing and cross-checking of the single encoder input in a 1oo2 architecture.
3. Choose the P28 [Fbk 1 Type] parameter.
The default value is 1 for incremental encoder input.
4. Set the P28 [Fbk 1 Type] parameter value to 0 for Sine/Cosine and internal monitoring of the single encoder input.
5. Choose the P29 [Fbk 1 Units] parameter.
6. Set the P29 [Fbk 1 Units] parameter to 0 (default), which equals Rotary feedback.
7. Choose the P30 [Fbk 1 Polarity] parameter.
8. Set the P30 [Fbk 1 Polarity] parameter to 0 (default) to set up the direction for monitoring to be the same as the encoder direction (Normal).
9. Choose the P31 [Fbk 1 Resolution] parameter.
10. Choose 1024 (default) or enter value between 1...65,535 pulses/revolution based on the encoder's specifications.
11. Choose the P32 [Fbk 1 Volt Mon] parameter.

12. Enter 5, 9, or 12V to monitor voltage in accordance with the encoder's specifications, or enter 0 (default) to disable encoder voltage monitoring.

TIP The P33 [Fbk 1 Speed] parameter displays the output speed of the encoder as a value between -214,748,364.8...214,748,364.8 rpm based on the encoder's configuration. You do not need to enter a setting or value for this parameter.

13. Choose the P42 [Direction Mon] parameter.
14. Set the P42 [Direction Mon] parameter value to 2, to set up the normal monitored direction as Negative Always.
15. Choose the P43 [Direction Tol] parameter.
16. Enter value between 0...65,535 degrees based on the encoder's specifications.

The default value is 10 degrees.

This sets the position limit tolerated in the wrong direction when Safe Direction Monitoring is enabled. Entering 360 equals one revolution in the forward direction before a Direction Fault occurs.

17. Go to the next section to set the parameters found in the Stop parameters group.

Example 2: Stop Group Settings

Figure 56 - Stop Group Parameters

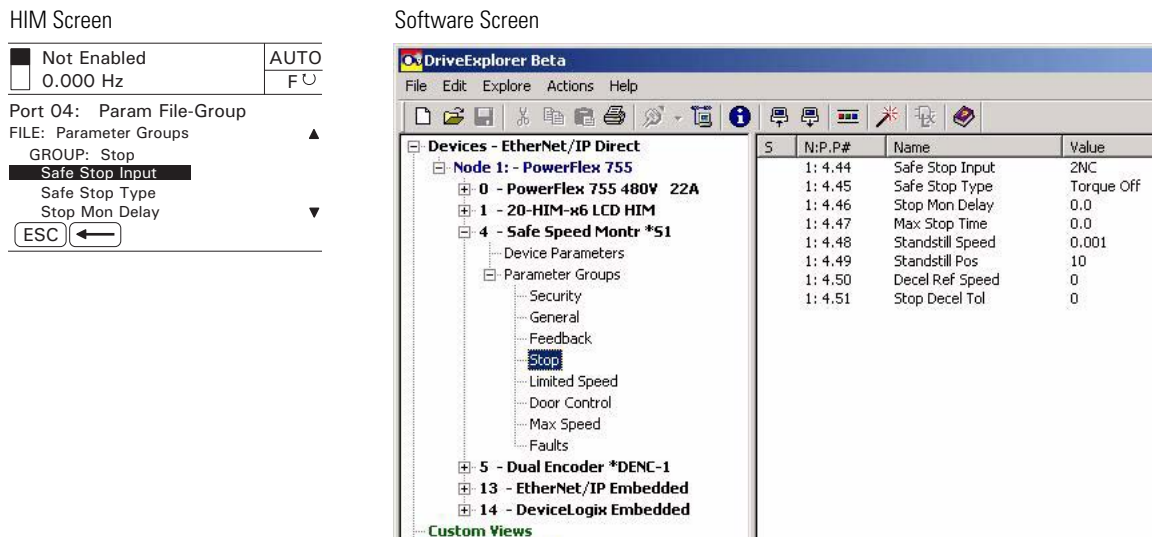

Follow these steps to configure the Stop operation of the safety option.

1. From the Stop group, choose the P44 [Safe Stop Input] parameter.

2. Set the P44 [Safe Stop Input] parameter value to 1 (default) for 2NC (dual-channel equivalent) operation.

In this example application, the Safe Stop input (SS_In) monitors an E-Stop button with two normally-closed (2NC) contacts.

3. Choose the P45 [Safe Stop Type] parameter.
4. Set the P45 [Safe Stop Type] parameter value to 1, which equals Safe Stop 1.

Safe Stop 1 monitors deceleration profiles. When Standstill Speed is detected within the Stop Delay [Max Stop Time], the safety option switches off Motion Power and sets door control logic to Unlock.

5. Choose the P47 [Max Stop Time] parameter.

The default value is 0 s, but you can enter a value from 0...6553.5 s.

6. Type the value of the expected ramp-to-stop time plus a reasonable tolerance after the Safe Stop command is initiated.

If the machine's speed is not below the Standstill Speed within the Max Stop Time period you entered, a Stop Speed Fault occurs and door control logic remains set to Lock until Standstill Speed is reached.

7. Choose the P48 [Standstill Speed] parameter.

The default value is 0.001 rpm, but you can enter a value from 0.001...65,535 rpm. The Standstill Speed is measured in revolutions per minute, because the P29 [Fbk 1 Units] parameter is configured for Rotary feedback.

8. Enter a value in the P48 [Standstill Speed] parameter field to define the speed at which the safety option determines standstill has been reached.

9. Choose the P49 [Standstill Pos] parameter.

The default value is 10 degrees, but you can enter a value from 0...65,535 degrees. The Standstill Position is measured in degrees because the P29 [Fbk 1 Units] parameter is configured for Rotary feedback.

10. Enter the value to define the position limit in encoder units that is tolerated after standstill has been reached.

11. Choose the P50 [Decel Ref Speed] parameter.

The default value is 0 RPM, but you can enter a value from 0...65,535 RPM. The Decel Ref Speed parameter is used to verify that the speed is decelerating at the desired rate.

12. Enter a number greater than the Max Speed (2000 in this example).

13. Choose the P51 [Stop Decel Tol] parameter.

The Stop Decel Tol parameter determines the total percentage of the Decel Ref Speed that is used as the upper limit of deceleration speed.

14. Enter 100% for this example.

- Go to the next section to set the parameters found in the Limited Speed parameters group.

Example 2: Limited Speed Group Settings

Figure 57 - Limited Speed Group Parameters

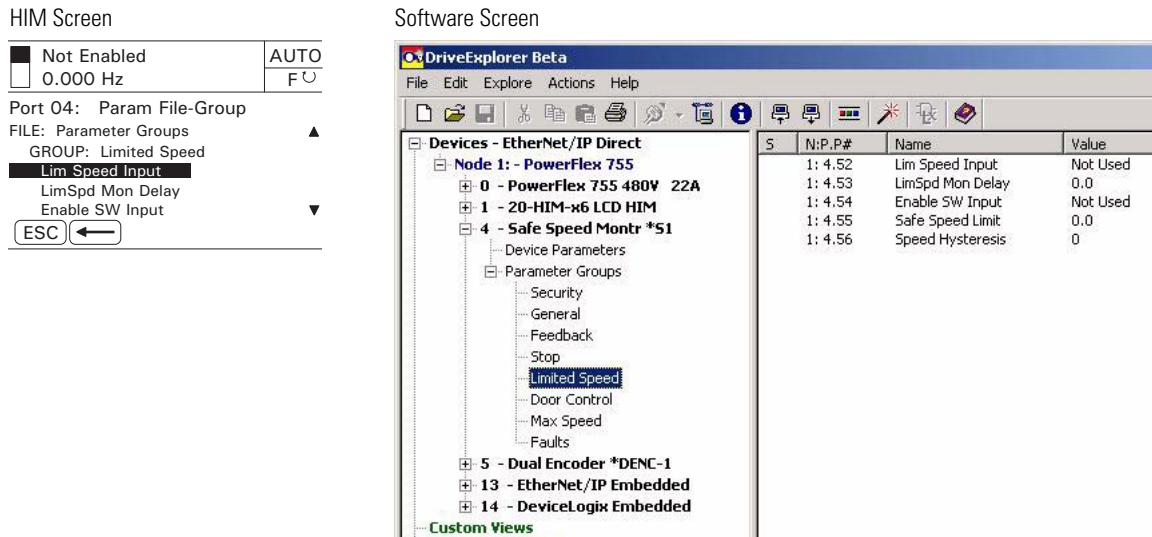

Follow these steps to configure the Safe Limited Speed operation.

- From the Limited Speed group, choose the P52 [Lim Speed Input] parameter.

The default value is 0 (Disabled), for applications without Safe Limited Speed control.

- Set the P52 [Lim Speed Input] parameter value to 1 for 2NC (dual-channel equivalent) operation.

In this example application, the Safe Limited Speed input (SLS_In) monitors a switch with two normally-closed (2NC) contacts. If the NC contacts are open and speed exceeds the configured Safe Limited Speed, the safety option initiates the configured Safe Stop Type.

When the safety option is actively monitoring Safe Limited Speed and the machine's speed is at or below the configured Safe Speed Limit, the gate interlock is released and the door can be opened.

- Choose the P53 [LimSpd Mon Delay] parameter.

The default value is 0 s. The valid range is from 0...6553.5 s.

Type a value to define the desired delay between the SLS_In input ON to OFF transition and the start of Safe Limited Speed monitoring.

- Choose the P54 [Enable SW Input] parameter.

The default value is 0 (Not Used) for applications without an enabling switch.

- Set the P54 [Enable SW Input] parameter value to 1 for 2NC (dual-channel equivalent) operation.

In this example application, the ESM_In input monitors an enabling switch with two normally-closed (2NC) contacts. As long as the enabling switch is held in the middle position, the safety gate can be opened during Safe Limited Speed monitoring.

- Choose the P55 [Safe Speed Limit] parameter.

The default value is 0 rpm or mm/s. Enter a value from 0...6553.5.

- Type the maximum allowable rpm value for safe (reduced) velocity.

The speed is calculated in rpm, based on the P29 {Fbk 1 Units} parameter setting (0 = Rotary feedback) entered previously.

- Go to the next section to set the parameters that configure Door Control operation.

Example 2: Door Control Group Settings

Figure 58 - Door Control Group Parameters

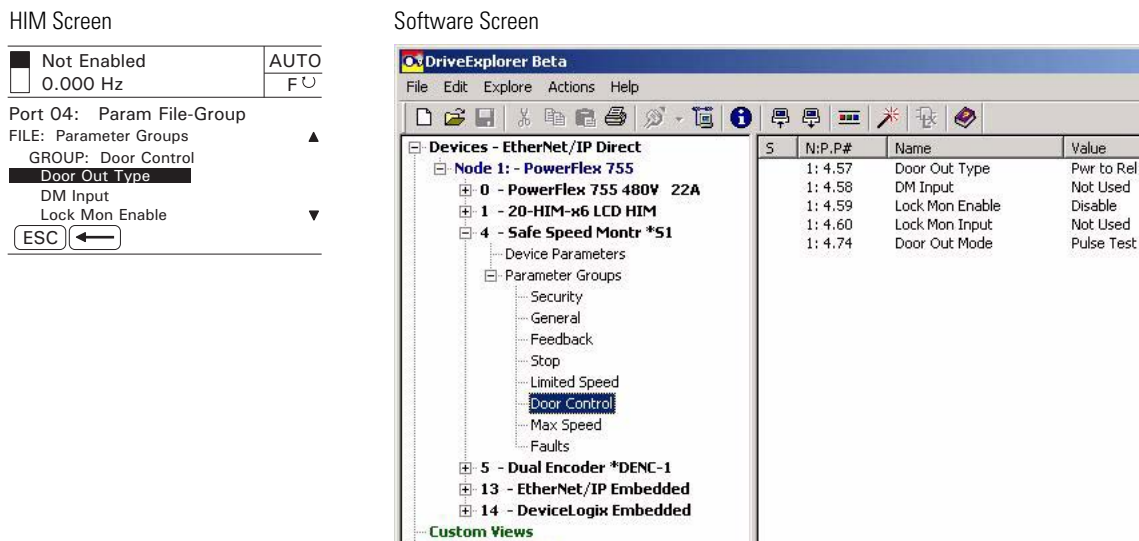

Follow these steps to configure Door Control operation for the safety option.

- From the Door Control group, choose the P57 [Door Out Type] parameter.
- Set the P57 [Door Out Type] parameter to 0 (default), which equals Power to Release (Pwr to Rel).

This setting was chosen because power must be applied to the solenoid inside the TLS-3 GD2 gate switch to release the gate interlock.

3. Choose the P58 [DM Input] parameter.

The default setting is 0 for applications that do not use an interlock switch.

4. Set the P58 [DM Input] parameter value to 1 for 2NC (dual-channel equivalent) operation.

In this example application, the DM Input (DM_In) monitors the TLS-3 GD2 switch, which has two normally-closed (2NC) safety contacts.

5. Choose the P59 [Lock Mon Enable] parameter.

The default value is 0 (Disabled) for applications without an interlock switch.

6. Set the P59 [Lock Mon Enable] parameter value to 1 (Enabled) because this application uses the TLS-3 GD2 interlock switch.

7. Choose the P60 [Lock Mon Input] parameter.

The default value is 0 (Not Used) for applications that do not use an interlock switch.

8. Set the P60 [Lock Mon Input] parameter value to 1 for 2NC (dual-channel equivalent) operation.

In this example application, the Lock Monitor Input (LM_In) monitors the TLS-3 GD2 switch, which has two normally-closed (2NC) interlock monitoring contacts.

9. Go to the next section to set the parameters that configure Safe Maximum Speed monitoring.

Example 2: Max Speed Group

Figure 59 - Max Speed Group Parameters

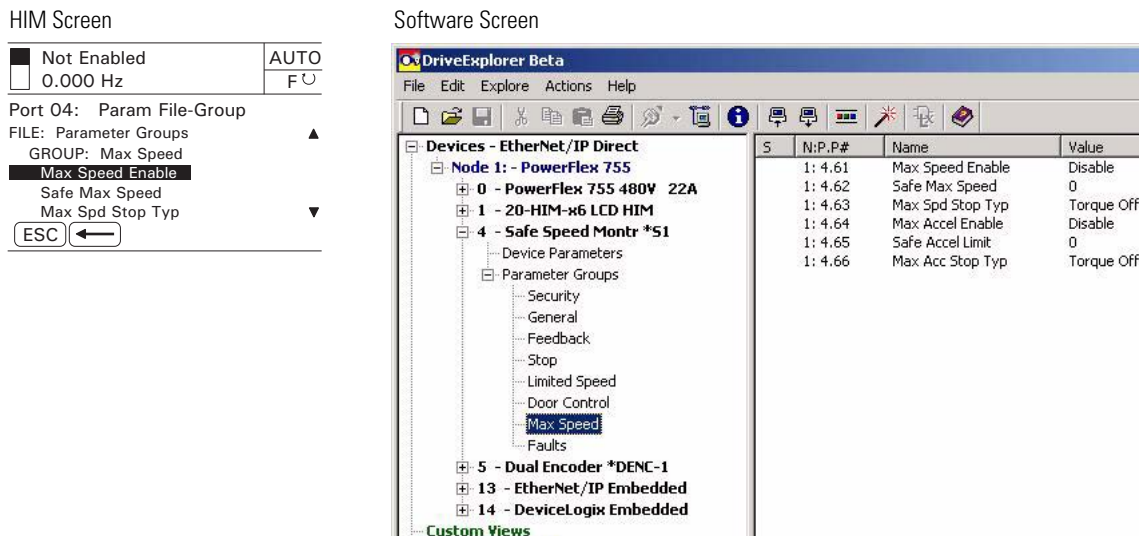

Follow these steps to configure Maximum Speed monitoring for the safety option.

1. From the Max Speed group, choose the P61 [Max Speed Enable] parameter.

The default value is 0 (Disabled) for no maximum speed limitation.

2. Set the P61 [Max Speed Enable] parameter value to 1 (Enabled), which monitors that the encoder feedback signal does not exceed the velocity configured by using the Safe Max Speed parameter.

3. Choose the P62 [Safe Max Speed] parameter.

The default value is 0 rpm or mm/s. Enter a value from 0...6553.5.

4. Type the maximum allowable rpm value for velocity.

The speed is calculated in rpm, based on the Fbk 1 Units parameter setting (0 = Rotary feedback) entered previously.

5. Choose the P63 [Max Spd Stop Typ] parameter.

6. Set the P63 [Max Spd Stop Typ] parameter value to 1, which equals Use Configured Safe Stop Type (Safe Stp Typ).

With this configuration, if speed exceeds the configured Safe Max Speed, the safety option initiates the configured Safe Stop Type.

7. Go on to the next section to put the safety option into Run mode and lock the configuration.

Example 2: Final Security Group Settings

This example includes only the steps for entering a configuration by using the HIM module or software program. You must also follow the requirements described in [Chapter 10](#), Safety Configuration and Verification.



ATTENTION: You must verify the configuration and validate the entire system, including a complete functional test, before the operational startup of any safety-related system.

Only authorized, specially-trained personnel, experienced in the commissioning and operation of safety-related systems may configure, test, and confirm the project.

Follow these steps to put the safety option into Run mode, generate a configuration signature, and lock the configuration.

1. From the Security group, choose the P6 [Operating Mode] parameter.
2. Set the P6 [Operating Mode] parameter value to 1, which equals Run mode.

A configuration signature is generated.

3. Choose the P10 [Signature ID] parameter and record the configuration signature value stored in this parameter.
4. If you configured a password, choose the P1 [Password] parameter and type the password.
5. Choose the P5 [Lock State] parameter.
6. Set the P5 [Lock State] parameter value to 1 (Lock) to lock the configuration.

Notes:

Troubleshooting the PowerFlex Safety Option Module

efesotomasyon.com

Introduction

This chapter provides troubleshooting tables for diagnosing fault conditions associated with the PowerFlex safety option module.

Topic	Page
Status Indicators	151
Nonrecoverable Faults	152
Fault Recovery	152
Fault Codes and Descriptions	152
Fault Reactions	155
Status Attributes	156

Status Indicators

The safety option features two indicators to provide status information.

Indicator	Status	Description
P/F	Green/On	The safety option is operating normally and is in Run mode.
	Red/Flashing	A recoverable fault has occurred.
	Red/On	A nonrecoverable fault has occurred. (All other indicators are OFF.)
	Red/Green Flashing	The configuration is being downloaded or a firmware upgrade is in progress.
MP	Green/On	Motion Power is enabled.
	Off	Motion Power is disabled.
	Red/Flashing	A Motion Power fault has been detected.

Nonrecoverable Faults

In addition to the recoverable faults described in this chapter, the safety option also generates nonrecoverable faults when an anomaly with the safety option hardware is detected. These faults are Safe State faults. If a Safe State fault occurs, all safety control outputs are set to their safe state.

To clear a nonrecoverable fault, cycle power. If the nonrecoverable fault persists, the safety option may need to be replaced.

Fault Recovery

If the fault is no longer present, you can clear the fault condition with a successful SS Reset and drive fault Clear command, except in the case of an Invalid Configuration fault, MP Out fault, or Reset PwrUp fault. An Invalid Configuration fault is cleared by a successful reconfiguration. An MP Out fault or Reset PwrUp fault is cleared at power down or by a successful reconfiguration.

Input and Output Faults

An input or output fault indication can be caused by several wiring fault conditions during commissioning or normal operation. If an input fault occurs, check for the following:

- One of the channels may have shorted to a 24V DC source.
- One of the channels may have shorted to a GND source.
- Two input channels have shorted together.
- One or both output channels have an overcurrent condition.

An input fault may also occur if only one of the channels in a dual-channel system changed state after a 3-second discrepancy time interval, and if the inputs are configured with one of these settings:

- 2 = Dual-channel equivalent 3 s (2NC 3s)
- 4 = Dual-channel complementary 3 s (1NC + 1NO 3s)
- 5 = Dual-channel SS equivalent 3 s (2 OSSD 3s)

Fault Codes and Descriptions

Faults fall into one of three categories: Stop Category fault, Fault While Stopping fault, and Safe State fault. Stop Category faults can be Motion faults, Monitor faults, or I/O faults.

The HIM module or configuration software can display a fault history queue, which provides a record of the faults detected by the safety option. The fault history queue stores the fault codes and timestamps for the last 10 faults that occurred. To avoid confusion about when faults occurred, a power-up marker (code 32) is placed between faults in the queue if the safety option is powered up or reset when the queue is not empty. Code 0 equals No Entry.

These tables list the faults, fault codes, and display text for each fault. You can view these faults by accessing the P67 [Fault Status] parameter.

Table 17 - Safe State Faults

Code	Display Text	Description
0	Combined Flt	A combined fault is indicated if any error has occurred.
1	Critical Flt	A nonrecoverable microprocessor error has occurred.
2	Invalid Cfg	An Invalid Configuration fault occurs if a configuration parameter is set to an illegal value or combination of values. See the Configuration Fault Codes on page 159 .
3	MP Out Flt	An MP Output fault occurs if an error is detected in the Motion Power command to the drive. If you are not using the DiO digital input on the drive's main control board as a 'hardware enable', verify that J1 ENABLE jumper, also on the drive's main control board, is installed
4	Reset PwrUp	A Reset Powerup fault occurs if the reset type is configured for Manual or Manual Monitored and the Reset_In input is detected as ON when power is cycled.
5	Fbk 1 Flt	A Feedback 1 fault occurs if any of these conditions are detected at encoder 1: <ul style="list-style-type: none"> • An open wire is detected. • A short-circuit is detected. • A sine/cosine fault exists, that is the amplitude of the sine signal squared plus the amplitude of the cosine signal squared is not equal to a constant value. • The feedback signals indicate a frequency greater than or equal to 100 kHz for a Sine/cosine encoder or 200 kHz for an incremental encoder. • Illegal encoder signal transitions are detected.
6	Fbk 2 Flt	A Feedback 2 fault occurs if any of these conditions are detected at encoder 2: <ul style="list-style-type: none"> • Illegal encoder signal transitions are detected. • The feedback signals indicate a frequency greater than or equal to 200 kHz.
7	Dual Fbk Spd	A Dual Feedback Speed fault occurs if an error is detected between the speed from the first encoder and the speed from the second encoder. Valid speed-comparison values are determined by the configured Feedback Speed Ratio and Feedback Speed Tolerance.
8	Dual Fbk Pos	A Dual Feedback Position fault occurs if a discrepancy is detected between the relative position change of the encoder 1 and the relative position change of encoder 2 since the last SS Reset.
13	Mov in Stop	If the safety option is configured for a stop type that includes stopped speed checking, a Mov in Stop fault occurs if either of the following is detected after the system is stopped and the door has been unlocked: <ul style="list-style-type: none"> • Speed greater than the configured Standstill Speed • A position change greater than the configured Standstill Position limit
27	Fbk 1 V Fault	An Encoder 1 Voltage fault occurs if the encoder voltage at encoder 1 is detected as out of range.
28	Fbk 2 V Fault	An Encoder 2 Voltage fault occurs if the encoder voltage at encoder 2 is detected as out of range.

Table 18 - Fault While Stopping Faults

Code	Display Text	Description
11	Decel Flt	A Deceleration fault occurs if the speed is detected at greater than the limit specified for the configured Stop Delay [Max Stop Time] when the configured Safe Stop Type is Safe Stop 1 or 2.
12	Stop Spd Flt	A Stop Speed fault occurs when the safety option is configured for a Safe Stop Type that includes Standstill Speed checking (Safe Stop 1 or 2, and Safe Torque Off with Standstill Speed Checking) and the detected speed is greater than the configured Standstill Speed at the end of the configured Stop Delay [Max Stop Time].

Table 19 - Stop Category Faults

Code	Display Text	Description	
9	SS In Flt	I/O Faults ⁽¹⁾	An SS_In fault occurs if an error is detected in the SS_In dual-channel input.
10	SS Out Flt		An SS_Out fault occurs if an error is detected in the SS_Out dual-channel output.
14	SLS In Flt		An SLS_In fault occurs if an error is detected in the SLS_In dual-channel input.
15	SLS Out Flt		An SLS_Out fault occurs if an error is detected in the SLS_Out dual-channel output.
20	DM In Flt		A DM_In fault occurs if an error is detected in the DM_In dual-channel input.
22	DC Out Flt		A DC_Out fault occurs if an error is detected in the DC_Out dual-channel output.
23	LM In Flt		An LM_In fault occurs if an error is detected in the LM_In dual-channel input.
25	ESM In Flt		An ESM_In fault occurs if an error is detected in the ESM_In dual-channel input.
16	SLS Speed Flt	Motion Faults	The monitored speed was detected at greater than or equal to the Safe Speed Limit during Safe Limited Speed monitoring.
17	SMS Spd Flt		A Safe Maximum Speed fault indicates that Safe Maximum Speed (SMS) monitoring is enabled and the monitored speed was detected at greater than or equal to the configured Safe Max Speed.
18	Accel Flt		An Acceleration fault indicates that the monitored speed was detected as greater than or equal to the configured Safe Accel Rate during safe acceleration monitoring.
19	Dir Flt		A Direction fault indicates that motion was detected in the restricted direction during safe direction monitoring (SDM).
21	Door Mon Flt	Monitor Fault	<p>If the safety option is configured for Safe Limited Speed (SLS), but SLS monitoring is not active, the DM_In input must be ON (door closed) or a Door Monitoring fault occurs.</p> <p>A Door Monitoring fault occurs if the door is open (DM_In input is OFF) when an SS Reset or SLS Reset is requested (SLS_In transitions to ON).</p> <p>If a configured SLS Monitoring Delay P53 [LimSpd Mon Delay] is in progress prior to Safe Limited Speed monitoring being active and the DM_In input is OFF (door open), a Door Monitoring fault occurs.</p> <p>If the safety option is configured for door monitoring and enabling switch monitoring and is actively monitoring safe limited speed, a Door Monitoring fault occurs if the DM_In input transitions from ON to OFF (door is opened), while the ESM_In input is OFF.</p>
26	ESM Mon Flt		<p>If the safety option is configured for enabling switch monitoring and is actively monitoring safe limited speed, the ESM_In input must be ON or an ESM Monitoring fault occurs.</p> <p>If the safety option is configured for enabling switch monitoring only and a configured SLS monitoring delay [LimSpd Mon Delay] is in progress, the ESM_In input must be ON when the delay times out or an ESM Monitoring fault occurs.</p> <p>If the ESM_In input is ON while the safety option is actively monitoring safe limited speed, the door can be opened (DM_In transitions from ON to OFF) if no Lock Monitoring fault exists. However, if the ESM_In input transitions to OFF after the door has been opened, an ESM Monitoring fault occurs.</p> <p>If you attempt an SS Reset while the SLS_In input is OFF and the ESM_In input is OFF, an ESM Monitoring fault occurs.</p>
24	Lock Mon Flt		<p>If the safety option is configured for lock monitoring, a Lock Monitoring fault occurs when:</p> <ul style="list-style-type: none"> the LM_In input is detected as OFF while the door control output is in the Lock state, except for the 5 seconds following the transition of the DC_Out output from Unlock to Lock. the LM_In input is detected as ON when the DM_In signal transitioned from ON to OFF.

(1) Refer to Input and Output Faults on [page 152](#) for more information.

Fault Reactions

When a fault occurs, the type of fault and the status of the system determine the resulting state of the system.

Safe State Faults

If a Safe State fault occurs in any operational state including the Disabled state, the safety option goes to the Safe State. In the Safe State, all safety outputs are in their safe states.

Stop Category Faults and Fault While Stopping Faults

If a Stop Category fault or Fault While Stopping fault occurs while the safety option is monitoring motion, the safety option initiates the configured Safe Stop Type.

The type of fault detected determines the safety option's response when the fault occurs while the safety option is executing the configured Safe Stop Type.

Type of Fault Detected	Response
Fault While Stopping Faults: <ul style="list-style-type: none"> Deceleration fault (Decel Flt) Stop Speed fault (Stop Spd Flt) 	Outputs are placed in a faulted state, but door control logic can be set to Unlock if feedback signals indicate that Standstill Speed has been reached. The safety option continues to monitor for faults.
These Stop Category Faults: <ul style="list-style-type: none"> SMS Speed fault when the P63 [Max Spd Stop Typ] is configured for Use Safe Torque Off with Check for Standstill (Torque Off) Acceleration fault when the P66 [Max Acc Stop Typ] is configured for Use Safe Torque Off with Check for Standstill (Torque Off) Direction fault (Dir Flt), if the fault occurred while a safe stop was in progress. 	
These Stop Category faults: <ul style="list-style-type: none"> SLS Speed fault (SLS Spd Flt) Direction fault (Dir Flt), if the fault was detected before the safe stop was initiated. In this case, the safety option does not perform Direction Monitoring while executing the configured Safe Stop Type. Door Monitoring fault (Door Mon Flt) ESM Monitoring fault (ESM Mon Flt) Lock Monitoring fault (Lock Mon Flt) SMS Speed fault when the P63 [Max Spd Stop Typ] is configured for Use Configured Safe Stop Type (Safe Stp Typ) Acceleration fault when the P66 [Max Acc Stop Typ] is configured for Use Configured Safe Stop Type (Safe Stp Typ) 	The safety option continues to execute the configured Safe Stop Type and monitor for faults.

If outputs are already in a faulted state due to a previous fault, and a subsequent Stop Category fault or Fault While Stopping fault occurs, outputs remain in a faulted state, door control logic can be set to Unlock if feedback signals indicate that Standstill Speed has been reached, and the safety option continues to monitor for faults.

If a Stop Category fault or Fault While Stopping fault occurs after Standstill Speed has been reached and the safety option has set door control logic to Unlock, the safety option goes to the Safe State.



ATTENTION: If a fault occurs after Standstill Speed has been reached, door control logic remains unlocked.

A Safe State fault may set the Door Control output (DC_Out) to OFF.

Status Attributes

For diagnostic purposes only, you can view status attributes by accessing the P68 [Guard Status] parameter and the P69 [IO Diag Status] parameter from a HIM or via DriveExplorer or DriveExecutive software.

The status attributes are valid only when the safety option is in Run mode. If the safety option is in Program mode or has an Invalid Configuration Fault, the status attributes are not updated.

Guard Status Attributes

These attributes are stored in the P68 [Guard Status] parameter. Each bit corresponds to a different attribute.

Bit	Display Text	Description
0	StatusOK	This bit indicates when there are no faults. It is set (1), when all of the Fault Status bits 1...31 are 0 (no faults). The bit is 0 if any Fault Status bit from 1...31 indicates a fault (1).
1	Config Lock	This bit shows the status of the P5 [Lock State] parameter. A 1 indicates the configuration is locked; a 0 indicates the configuration is unlocked.
2	MP_Out	This bit shows the status of the safety option's Motion Power command to the drive. A 1 indicates Motion Power is enabled; a 0 indicates Motion Power is disabled.
3	SS In	This bit displays the logical value, 1 or 0, evaluated for the dual-channel SS_In input.
4	SS Req	This bit is set to 1 when a safe stop is initiated by either a transition of the SS_In input from ON to OFF or by a Stop Category fault. This bit is reset to 0 when a successful SS Reset occurs and when the Safety mode is set to Disabled (0).
5	SS In Prog	This bit is set to 1 when a safe stop is initiated by the transition of the SS_In input from ON to OFF with no active fault conditions. It is not set to 1 when a Safe Stop is initiated by a Stop Category fault. While set to 1, this bit will be reset (0) if Standstill Speed is reached or any fault condition is detected.
6	SS Decel	This bit is set to 1 if the configured Stop Delay [Max Stop Time] is active for a Safe Stop 1 or Safe Stop 2 while the safety option is executing the Safe Stop. This bit is not set during a Category 0 Safe Torque Off Safe Stop. This bit is reset (0) when Standstill Speed is detected, a Safe State fault occurs, or a SS Reset occurs.

Bit	Display Text	Description
7	SS Stopped	This bit is set to 1 if a successful Safe Stop has been executed and the speed is less than or equal to the Standstill Speed. This bit is set to 0 by an SS Reset or the occurrence of a Stop Category fault. It is always 0 when the safety option is configured for a Safe Torque Off without Standstill Speed Checking.
8	SS Out	This bit is set to 1 if the dual-channel SS_Out output is being commanded to the ON state. This bit is the commanded value, not a readback value. This bit is set to 0 if the SS_Out output is being commanded to the OFF state.
9	SLS In	This bit reflects the logical value evaluated for the dual-channel SLS_In input.
10	SLS Req	This bit is set to 1, if the Safe Limited Speed operation has been requested while the safety option is actively monitoring motion or a SLS Monitoring Delay [LimSpd Mon Delay] is in progress.
11	SLS In Prog	This bit is set to 1 when Safe Limited Speed monitoring is active.
12	SLS Out	This bit is set to 1 if the dual-channel SLS_Out output is being commanded to the ON state. This bit is the commanded value, not a readback value.
13	SMS In Prog	This bit is set to a 1, if Safe Maximum Speed monitoring is enabled and Safe Maximum Speed is being monitored.
14	SMA In Prog	This bit is set to 1, if Safe Maximum Acceleration monitoring is enabled and safe maximum acceleration is actively being monitored.
15	SDM In Prog	If Safe Direction monitoring is enabled and configured for Positive Always or Negative Always, the SDM_In_Progress bit is set to 1 any time the safety option is configured for any Safety mode other than Disabled. If Safe Direction monitoring is enabled and configured for Positive During SLS or Negative During SLS, then this bit is set to 1 if the safety option is actively monitoring for Safe Limited Speed. It is set to 0 in any other operating mode.
16	DC Lock	This bit is set to 1 if door control logic status is Lock. This bit is set to 0 if door control logic status is Unlock.
17	DC Out	This bit is set to 1 if the dual-channel DC_Out output is being commanded to the ON state. This is the commanded value, not the readback value. This bit is set to 0, if the dual-channel DC_Out output is being commanded to the OFF state.
18	DM In	This bit is set to 1 if the logical value of the dual-channel DM_In input is evaluated as 1. This bit is set to 0 if the logical value of the dual-channel DM_In input is evaluated as 0.
19	DM In Prog	The status of this bit is dependent on the safety option's speed monitoring configuration. The bit is 1 when: <ul style="list-style-type: none"> • the safety option is configured for Safe Stop with Door Monitoring and is monitoring motion, or is executing a Safe Stop. • the safety option is configured for Safe Limited Speed with Door Monitoring and the safety option is not actively monitoring for Safe Limited Speed, is in a SLS Monitoring Delay [LimSpd Mon Delay], or is executing a Safe Stop. • the safety option is configured for Safe Limited Speed with Door Monitoring and Enabling Switch Monitoring, and <ul style="list-style-type: none"> – the safety option is not actively monitoring for Safe Limited Speed, is in a SLS Monitoring Delay [LimSpd Mon Delay], or is executing a Safe Stop. – the safety option is actively monitoring for Safe Limited Speed when the ESM_In input is OFF and the DM_In input is ON. This bit is always set to 0 when the safety option is not configured for Door Monitoring.
20	LM In	This bit is set to 1 if the logical value of the dual-channel LM_In input is evaluated as 1. This bit is set to 0 if the logical value of the dual-channel LM_In input is evaluated as 0.
21	ESM In	This bit is set to 1 if the logical value of the dual-channel ESM_In input is evaluated as 1. This bit is set to 0 if the logical value of the dual-channel ESM_In input is evaluated as 0.
22	ESM In Prog	This bit is set to 1 if the Safety mode is configured for Enabling Switch Monitoring, Safe Limited Speed monitoring is active, and the SLS_In input is OFF. It is also set to 1 if the Safety mode is configured for Enabling Switch Monitoring and Door Monitoring and the DM_In input is OFF. This bit is set to 0 when the Safety mode is not configured for Enabling Switch Monitoring.
23	Reset In	This status bit reflects the state of the Reset_In input. A 1 indicates the Reset_In input is ON; a 0 indicates the Reset_In input is OFF.
24	Wait Reset	This bit indicates when an SS Reset is required. The bit is set to 1 whenever the safety option is successfully configured and is in the Safe State or when Standstill Speed has been reached.
25	Wait SS Cyc	This bit indicates when the SS_In input must be cycled prior to a SS Reset being performed. The bit is set to 1 if the SS_In input is ON and a fault is detected or the Wait Stop Request attribute equals 1. It is set to 0 if the SS_In input is detected as OFF.
26	Wait No Stop	This bit is set to 1 when a stop request is made by using the HIM stop button. It is set to 0 when the HIM start button is pushed, following a reset, or at powerup.

Bit	Display Text	Description
27	SLS Cmd	This bit is set to 1 when the safety option is commanding the drive to operate in limited speed mode.
28	Stop Cmd	This bit is set to 0 when the safety option is commanding the drive to stop.
29	Reserved	
:		
31		

I/O Diagnostic Status Attributes

These attributes are stored in the P69 [IO Diag Status] parameter. Each bit reflects the present state of I/O signal and is used for diagnostics: 0 = open; 1 = closed.

Bit	Display Text
0	SS In Ch 0
1	SS In Ch 1
2	SS Out Ch 0
3	SS_Out Ch 1
4	SLS In Ch 0
5	SLS In Ch 1
6	SLS Out Ch 0
7	SLS Out Ch 1
8	ESM In Ch 0
9	ESM In Ch 1
10	DM In Ch 0
11	DM In Ch 1
12	DC Out Ch 0
13	DC Out Ch 1
14	LM In Ch 0
15	LM In Ch 1
16	Reset In
17	Reserved
18	SLS Cmd
19	Stop Cmd
20	MP Out Ch 0 ⁽¹⁾
21	MP Out Ch 1
Bits 22...31 are Reserved.	

(1) Refer to Guard Status Attributes, bit 2, on page [156](#).

IMPORTANT When the safety option is not in Run mode, the P69 [IO Diag Status] parameter is not updated.

Configuration Fault Codes

Use these fault codes, stored in the P70 [Config Flt Code] parameter, to identify the reason for an Invalid Configuration fault.

Value	Description	Display
0	No fault.	No Fault
1	Password Required.	Password Req
2	P21 [Safety Mode] value not legal based on P20 [Cascaded Config] value.	P21 (P20)
3	P57 [Door Out Type] value not legal based on P20 [Cascaded Config] value.	P57 (P20)
4	P46 [Stop Mon Delay] value not legal based on P45 [Safe Stop Type] value.	P46 (P45)
5	P50 [Decel Ref Spd] value not legal based on P31 [Fbk 1 Resolution] value.	P50 (P31)
6	P48 [Standstill Speed] value not legal based on P20 [Cascaded Config] value.	P48 (P20)
7	P53 [LimSpd MonDelay] value not legal based on P21 [Safety Mode] value.	P53 (P21)
8	P55 [Safe Speed Limit] value not legal based on P21 [Safety Mode] or P31 [Fbk 1 Resolution] value.	P55 (P21 P31)
9	P56 [Speed Hysteresis] value not legal based on P21 [Safety Mode] value.	P56 (P21)
10	P62 [Safe Max Speed] value not legal based on P31 [Fbk 1 Resolution] value.	P62 (P31)
11	P42 [Direction Mon] value not legal based on P21 [Safety Mode] value.	P42 (21)
12	P59 [Lock Mon Enable] value not legal based on P21 [Safety Mode] value.	P59 (P21)
13	P36 [Fbk 2 Resolution] value not legal based on P27 [Fbk Mode] value.	P36 (P27)
14	P35 [Fbk 2 Polarity] value not legal based on P27 [Fbk Mode] value.	P35 (P27)
15	P39 [Fbk SpeedRatio] value not legal based on P27 [Fbk Mode] value.	P39 (P27)
16	P41 [Fbk Pos Tol] value not legal based on P27 [Fbk Mode] value.	P41 (P27)
17	P40 [Fbk Speed Tol] value not legal based on P27 [Fbk Mode] value.	P40 (P27)
18	P44 [Safe Stop Input] value not legal based on P21 [Safety Mode] value.	P44 (P21)
19	P52 [Lim Speed Input] value not legal based on P21 [Safety Mode] value.	P52 (P21)
20	P58 [DM Input] value not legal based on P20 [Cascaded Config] and P21 [Safety Mode] value.	P58 (P20 P21)
21	P54 [Enable SW Input] value not legal based on P21 [Safety Mode] value.	P54 (P21)
22	P60 [Lock Mon Input] value not legal based on P21 [Safety Mode] value and P59 [Lock Mon Enable] value.	P60 (P21 P59)
23	Illegal P20 [Cascaded Config] value.	P20
24	Illegal P22 [Reset Type] value.	P22
25	Reserved.	Reserved
26	Illegal P45 [Safe Stop Type] value.	P45
27	Illegal P51 [Stop Decel Tol] value.	P51
28	Illegal P27 [Fbk Mode] value.	P27
29	Illegal P28 [Fbk 1 Type] value.	P28
30	Illegal P31 [Fbk 1 Resolution] value.	P31
31	Illegal P32 [Fbk 1 Volt Mon] value.	P32
32	Illegal P37 [Fbk 2 Volt Mon] value.	P37
33	Illegal P24 [OverSpd Response] value.	P24
34	Reserved.	Reserved
35	Unknown error.	Unknown Err

Notes:

Specifications

efesotomasyon.com

Introduction

This appendix provides product specifications for the PowerFlex safety option module.

Topic	Page
General Specifications	161
Certifications	162
Encoder Specifications	162

General Specifications

These specifications apply to the PowerFlex safety option module.

Attribute	Value
Standards	IEC/EN60204-1, ISO12100, IEC 61508, IEC 61800-5-2
Safety category	Cat. 4 and PLe per EN ISO 13849-1; SIL CL3 per IEC 61508 and EN 62061
Power supply (user I/O)	24V DC $\pm 10\%$, 0.8...1.1 x rated voltage ⁽²⁾ PELV or SELV
Power consumption	36 W
SLS outputs 68, 78	24V DC, 20 mA, short-circuit protected
SS outputs 34, 44	24V DC, 20 mA, short-circuit protected
Door control outputs 51, 52	24V DC, short-circuit protected 0.75 A, bipolar (Power to Release/Power to Lock) configuration 20 mA, cascading (2Ch Source) configuration
Pulse outputs S11, S21	24V DC, 50 mA, short-circuit protected
Pulse inputs S12, S22, S32, S42, S52, S62, S72, S82, X32, X42	5 mA per input, max
Input ON Voltage, min	15V
Input OFF Voltage, max	5V
Input OFF Current, max	2 mA
Input-to-output response time (SS_In, SLS_In, DM_In, ESM_In, LM_In)	20 ms
Overspeed Response Time	User-configurable
Reset Input S34	5 mA per input, max
Conductor size ⁽¹⁾	0.25...2.5 mm ² (24...14 AWG)
Strip length	6 mm (0.25 in.)
Terminal screw torque	0.20...0.25 N•m (1.8...2.2 lb•in)

(1) Refer to Industrial Automation Wiring and Grounding Guidelines, publication [1770-4.1](#).

(2) Safety outputs need additional fuse for reverse voltage protection of the control circuit. Install a 6 A slow-blow or 10 A fast-acting fuse.

Certifications

See the Product Certification link at <http://www.ab.com> for Declarations of Conformity, Certificates, and other certifications details.

Agency Certification (1)	Value
c-UL-us (2)	UL Listed, certified for US and Canada.
CE	European Union 2004/108/EC EMC Directive, compliant with: EN 61800-3; categories C2 and C3 EN 62061; EM Immunity
C-Tick	Australian Radiocommunications Act, compliant with: EN 61800-3; categories C2 and C3
Functional Safety	Certified by TÜV for Functional Safety: up to SIL CL3, according to EN 61800-5-2, EN 61508, and EN 62061; up to Performance Level PLe and Category 4, according to EN ISO 13849-1; when used as described in this PowerFlex 750-Series Safety Reference Manual, publication 750-RM001.

(1) When product is marked, refer to <http://www.ab.com> for Declarations of Conformity Certificates.

(2) Underwriters Laboratories Inc. has not evaluated the safe-off, safe torque-off, or safe speed-monitoring options in these products.

Encoder Specifications

Use Belden 9728 cable with the following encoder specifications.

Type	Parameter	Description
Generic Incremental	Incremental encoder support	5, 9, and 12V, differential A quad B
	Differential input voltage (AM and BM)	1.0...7.0V
	High threshold level, min	3.5V
	Low threshold level, max	0.4V
	DC current draw (AM and BM)	60 mA, max
	Input signal frequency (AM and BM)	200 kHz, max
	Cable length, max	<ul style="list-style-type: none"> 183 m (600 ft) max cable length with 12V encoder 30.5 m (100 ft) max cable length with 5V encoder
Generic Sin/Cos	AM/BM input frequency	100 kHz, max
	AM/BM differential input voltage (p-p)	0.6...1.2V
Stegmann Sin/Cos	AM/BM input frequency	100 kHz, max
	AM/BM differential input voltage (p-p)	1V ±10%

Parameter Data

efesotomasyon.com

This appendix provides a description of the safety parameters, organized into both a linear list by parameter number, and into device-specific files and groups.

Parameter Groups

Parameters for the Safe Speed Monitor Option module appear in the groups Security, General, Feedback, Stop, Limited Speed, Door Control, Max Speed, and Faults.

Figure 60 - Safety Option Parameter Groups.

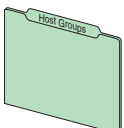
File	Group	Parameters							
	Security	Password	1	Reset Defaults	7	Password Command	17	Config Flt Code	70
		Lock State	5	Signature ID	10	Security Code	18		
		Operating Mode	6	New Password	13	Vendor Password	19		
	General	Cascaded Config	20	Reset Type	22	SS Out Mode	72		
		Safety Mode	21	OverSpd Response	24	SLS Out Mode	73		
	Feedback	Fbk Mode	27	Fbk 1 Type	28	Fbk 2 Units	34	Fbk Speed Ratio	39
				Fbk 1 Units	29	Fbk 2 Polarity	35	Fbk Speed Tol	40
				Fbk 1 Polarity	30	Fbk 2 Resolution	36	Fbk Pos Tol	41
				Fdk 1 Resolution	31	Fbk 2 Volt Mon	37	Direction Mon	42
				Fbk 1 Volt Mon	32	Fbk 2 Speed	38	Direction Tol	43
			Fbk 1 Speed	33					
Stop	Safe Stop Input	44	Stop Mon Delay	46	Standstill Speed	48	Decel Ref Speed	50	
	Safe Stop Type	45	Max Stop Time	47	Standstill Pos	49	Stop Decel Tol	51	
Limited Speed	Lim Speed Input	52	Enable SW Input	54	Safe Speed Limit	55	Speed Hysteresis	56	
	LimSpd Mon Delay	53							
Door Control	Door Out Type	57	DM Input	58	Lock Mon Enable	59	Door Out Mode	74	
					Lock Mon Input	60			
Max Speed	Max Speed Enable	61	Max Spd Stop Typ	63	Safe Accel Limit	65			
	Safe Max Speed	62	Max Accel Enable	64	Max Acc Stop Typ	66			
Faults	Fault Status	67	Guard Status	68	IO Diag Status	69	Config Flt Code	70	

Parameters and Settings in a Linear List

This table lists the configurable parameters and their valid settings in numerical order. If any values other than those listed in the table are configured for any of the parameters, an Invalid Configuration fault occurs.

File	Group	No.	Display Name Full Name Description	Values		Read-Write	Data Type
		HOST GROUPS	Security	1	Password Password Password for Lock and Unlock function.	Default: Min/Max:	N/A 0 / 4,294,967,295
5	Lock State Lock State Command to lock or unlock the safety option configuration.			Default: Options:	0 = "Unlock" 0 = "Unlock" 1 = "Lock"	RW	Real
6	Operating Mode Operating Mode Command to place the system in Program or Run mode.			Default: Options:	0 = "Program" 0 = "Program" 1 = "Run" 2 = "Config flt"	RW	Real
7	Reset Defaults Reset Defaults Resets safety option to factory defaults.			Default: Options:	0 = "No action" 0 = "No action" 1 = "Reset Fac" (Reset to factory defaults)	RW	Real
10	Signature ID Signature Identifier Safety configuration identifier.			Default: Min/Max:	N/A 0 / 4,294,967,295	RO	Real
13	New Password New Password 32-bit configuration password.			Default: Min/Max:	N/A 0 / 4,294,967,295	RW	Real
17	Password Command Password Command Save new password command.			Default: Options:	0 = "No action" 0 = "No action" 1 = "Change PW" (Change Password) 2 = "Reset PW" (Reset Password)	RW	Real
18	Security Code Security Code Used for Reset Password command.			Default: Min/Max:	N/A 0 / 65,535	RO	Real
19	Vendor Password Vendor Password Vendor password for Reset Password command.			Default: Min/Max:	N/A 0 / 65,535	RW	Real

File	Group	No.	Display Name Full Name Description	Values	Read-Write	Data Type
HOST GROUPS	General	20	Cascaded Config Cascaded Configuration Defines whether the speed monitoring safety option is a single unit or if it occupies a first, middle, or last position in a multi-axis cascaded system. "Single" (0) - Single Unit System "Multi First" (1) - Cascaded System First Unit "Multi Mid" (2) - Cascaded System Middle Unit "Multi Last" (3) - Cascaded System Last Unit	Default: 0 = "Single" Options: 0 = "Single" 1 = "Multi First" 2 = "Multi Mid" 3 = "Multi Last"	RW	Real
		21	Safety Mode Safety Mode Defines the primary operating mode of the speed monitoring safety functions. "Safe Stop" (1) - Master, Safe Stop "Safe Stop DM" (2) - Master, Safe Stop with Door Monitoring "Lim Speed" (3) - Master, Safe Limited Speed "Lim Speed DM" (4) - Master, Safe Limited Speed with Door Monitoring "Lim Speed ES" (5) - Master, Safe Limited Speed with Enabling Switch Control "LimSpd DM ES" (6) - Master, Safe Limited Speed with Door Monitoring and Enabling Switch Control "Lim Spd Stat" (7) - Master, Safe Limited Speed Status Only "Slv Safe Stp" (8) - Slave, Safe Stop "Slv Lim Spd" (9) - Slave, Safe Limited Speed "Slv Spd Stat" (10) - Slave, Safe Limited Speed Status Only	Default: 1 = "Safe Stop" Options: 0 = "Disabled" 1 = "Safe Stop" 2 = "Safe Stop DM" 3 = "Lim Speed" 4 = "Lim Speed DM" 5 = "Lim Speed ES" 6 = "LimSpd DM ES" 7 = "Lim Spd Stat" 8 = "Slv Safe Stp" 9 = "Slv Lim Spd" 10 = "Slv Spd Stat"	RW	Real
		22	Reset Type Reset Type Defines the type of reset used by the safety option.	Default: 2 = "Monitored" Options: 0 = "Automatic" 1 = "Manual" 2 = "Monitored" (Manual Monitored)	RW	Real
		24	OverSpd Response Over Speed Response Configuration for the feedback interface sampling rate.	Default: 0 = "42 ms" Options: 0 = "42 ms" 1 = "48 ms" 2 = "60 ms" 3 = "84 ms" 4 = "132 ms" 5 = "228 ms" 6 = "420 ms"	RW	Real

File	Group	No.	Display Name Full Name Description	Values		Read-Write	Data Type
HOST GROUPS	Feedback	27	Fbk Mode Feedback Mode Selects the number of feedback devices and the type of discrepancy checking. "Single Fbk" (0) - 1 Encoder "Dual S/P Chk" (1) - 2 Encoders with Speed and Position Discrepancy Checking "Dual Spd Chk" (2) - 2 Encoders with Speed Discrepancy Checking "Dual Pos Chk" (3) - 2 Encoders with Position Discrepancy Checking	Default: 0 = "Single Fbk" Options: 0 = "Single Fbk" 1 = "Dual S/P Chk" 2 = "Dual Spd Chk" 3 = "Dual Pos Chk"		RW	Real
		28	Fbk 1 Type Feedback 1 Type Selects the type of feedback for encoder 1. When using the Safe Speed Monitor module with a 20-750-UFB-1 Universal Feedback module, set this parameter to 0 "Sine/Cosine" and ensure that the Universal Feedback module is set to a Sine/Cosine type device (P6 [FB0 Device Sel] and/or P36 [FB1 Device Sel]).	Default: 1 = "TTL" Options: 0 = "Sine/Cosine" 1 = "TTL" (Incremental)		RW	Real
		29	Fbk 1 Units Feedback 1 Units Selects rotary or linear feedback for encoder 1.	Default: 0 = "Rev" Options: 0 = "Rev" (Rotary) 1 = "mm" (Linear)		RW	Real
		30	Fbk 1 Polarity Feedback 1 Polarity Defines the direction polarity for encoder 1.	Default: 0 = "Normal" Options: 0 = "Normal" (Same as encoder) 1 = "Reversed"		RW	Real
		31	Fbk 1 Resolution Feedback 1 Resolution Counts/Revolution. 1...65,535 pulses/revolution or pulses/mm based on rotary or linear configuration defined by P29 [Fbk 1 Units].	Default: 1024 Min/Max: 1 / 65,535		RO	Real
		32	Fbk 1 Volt Mon Feedback 1 Voltage Monitor Encoder 1 voltage to be monitored.	Default: 0 = Voltage not monitored Options: 0 = Voltage not monitored 5 = 5V +/- 5% 9 = 7...12V 12 = 12V +/- 5% 24 = 24V - 10%...24V + 5%		RW	Real
		33	Fbk 1 Speed Feedback 1 Speed Displays the output speed of encoder 1. Units based on rotary or linear configuration defined by P29 [Fbk 1 Units].	Units: RPM mm/s Min/Max: -214,748,364.8 / 214,748,364.7 RPM -214,748,364.8 / 214,748,364.7mm/s		RO	Real
		34	Fbk 2 Units Feedback 2 Units Selects rotary or linear feedback for encoder 2.	Default: 0 = "Rev" Options: 0 = "Rev" (Rotary) 1 = "mm" (Linear)		RW	Real
		35	Fbk 2 Polarity Feedback 2 Polarity Defines the direction polarity for encoder 2.	Default: 0 = "Normal" Options: 0 = "Normal" (Same as encoder) 1 = "Reversed"		RW	Real
		36	Fbk 2 Resolution Feedback 2 Resolution Counts/Revolution. 0...65,535 pulses/revolution or pulses/mm based on rotary or linear configuration defined by P34 [Fbk 2 Units].	Default: 0 Min/Max: 1 / 65,535		RO	Real

File	Group	No.	Display Name Full Name Description	Values		Read-Write	Data Type
HOST GROUPS	Feedback	37	Fbk 2 Volt Mon Feedback 2 Voltage Monitor Encoder 2 voltage to be monitored.	Default: 0 = Voltage not monitored Options: 0 = Voltage not monitored 5 = 5V +/- 5% 9 = 7...12V 12 = 12V +/- 5% 24 = 24V - 10%...24V + 5%		RW	Real
		38	Fbk 2 Speed Feedback 2 Speed Displays the output speed of encoder 2. Units based on rotary or linear configuration defined by P34 [Fbk 2 Units].	Units: RPM mm/s Min/Max: -214,748,364.8/214,748,364.7 RPM -214,748,364.8/214,748,364.7 mm/s		RO	Real
		39	Fbk Speed Ratio Feedback Speed Ratio Defines the ratio of the expected speed of encoder 2 divided by the expected speed of encoder 1. Ratio based on rotary or linear configuration defined by P29 [Fbk 1 Units].	Default: 0.0000 Min/Max: 0.0001 / 10,000.0		RW	Real
		40	Fbk Speed Tol Feedback Speed Tolerance Acceptable difference in speed between P33 [Fbk 1 Speed] and P38 [Fbk 2 Speed]. Units are based on rotary or linear configuration defined by P29 [Fbk 1 Units].	Units: RPM mm/s Min/Max: 0 / 6553.5 RPM 0 / 6553.5 mm/s		RW	Real
		41	Fbk Pos Tol Feedback Position Tolerance Acceptable difference in position between encoder 1 and encoder 2. Units are based on rotary or linear configuration defined by P29 [Fbk 1 Units].	Units: Deg mm Default: 0 Min/Max: 0 / 65,535 deg 0 / 65,535 mm		RW	Real
		42	Direction Mon Direction Monitoring Defines the allowable direction if Safe Direction Monitoring is enabled. "Pos Always" (1) – Positive always "Neg Always" (2) – Negative always "Pos in SLS" (3) – Positive during safe limited speed monitoring "Neg in SLS" (4) – Negative during safe limited speed monitoring	Default: 0 = "Disabled" Options: 0 = "Disabled" 1 = "Pos Always" 2 = "Neg Always" 3 = "Pos in SLS" 4 = "Neg in SLS"		RW	Real
		43	Direction Tol Direction Tolerance The position limit in encoder units tolerated in the wrong direction when Safe Direction Monitoring is active. Units are based on rotary or linear configuration defined by P29 [Fbk 1 Units].	Units: Deg mm Default: 10 Min/Max: 0 / 65,535 deg 0 / 65,535 mm		RW	Real

File	Group	No.	Display Name Full Name Description	Values		Read-Write	Data Type
HOST GROUPS	Stop	44	Safe Stop Input Safe Stop Input Configuration for Safe Stop input (SS_In). "2NC" (1) – Dual-channel equivalent "2NC 3s" (2) – Dual-channel equivalent 3 s "1NC+1NO" (3) – Dual-channel complementary "1NC+1NO 3s" (4) – Dual-channel complementary 3 s "2 OSSD 3s" (5) – Dual-channel SS equivalent 3 s "1NC" (6) – Single channel equivalent	Default: Options:	1 = "2NC" 0 = "Not used" 1 = "2NC" 2 = "2NC 3s" 3 = "1NC+1NO" 4 = "1NC+1NO 3s" 5 = "2 OSSD 3s" 6 = "1NC"	RW	Real
		45	Safe Stop Type Safe Stop Type Safe operating stop type selection. This defines the type of Safe Stop that is performed if the Safe Stop function is initiated by a stop type condition. "Torque Off" (0) – Safe Torque Off With Standstill Checking "Torque Off NoCk" (3) – Safe Torque Off Without Standstill Checking	Default: Options:	0 = "Torque Off" 0 = "Torque Off" 1 = "Safe Stop 1" 2 = "Safe Stop 2" 3 = "Torque Off NoCk"	RW	Real
		46	Stop Mon Delay Stop Monitoring Delay Defines the monitoring delay between the request and the Max Stop Time when the request for a Safe Stop 1 or a Safe Stop 2 is initiated by an SS_In input ON to OFF transition. If the Safe Stop Type is Safe Torque Off With or Without Standstill Speed Checking, the Stop Monitor Delay must be 0 or a Invalid Configuration Fault occurs.	Units: Default: Min/Max:	Secs 0 0 / 6553.5	RW	Real
		47	Max Stop Time Maximum Stop Time Defines the maximum stop delay time that is used when the Safe Stop function is initiated by a stop type condition.	Units: Default: Min/Max:	Secs 0 0 / 6553.5	RW	Real
		48	Standstill Speed Standstill Speed Defines the speed limit that is used to declare motion as stopped. Units are based on rotary or linear configuration defined by P29 [Fbk 1 Units]. Not valid for Safe Torque Off without Standstill Checking.	Units: Default: Min/Max:	RPM mm/s 0.001 0.001/ 65.535 RPM 000/ 65.535 mm/s	RW	Real
		49	Standstill Pos Standstill Position Defines the position limit window in encoder 1 degrees or mm that will be tolerated after a safe stop condition has been detected. Degrees (360° = 1 revolution) or mm based on rotary or linear configuration defined by P29 [Fbk 1 Units]. Not valid for Safe Torque Off without Standstill Checking.	Units: Default: Min/Max:	Deg mm 10 0 / 65,535 deg 0 / 65.535 mm	RW	Real
		50	Decel Ref Speed Deceleration Reference Speed Determines deceleration rate to monitor for Safe Stop 1 or Safe Stop 2. Units are based on rotary or linear configuration defined by encoder 1 feedback configuration, P29 [Fbk 1 Units].	Units: Default: Min/Max:	RPM mm/s 0 0 / 65,535 RPM 0 / 65,535 mm/s	RW	Real
		51	Stop Decel Tol Stop Deceleration Tolerance This is the acceptable tolerance above the deceleration rate set by the Decel Ref Speed parameter.	Units: Default: Min/Max:	% 0 0 / 100	RW	Real

File	Group	No.	Display Name Full Name Description	Values		Read-Write	Data Type
HOST GROUPS	Limited Speed	52	Lim Speed Input Limited Speed Input Configuration for Safe Limited Speed input (SLS_In). "2NC" (1) – Dual-channel equivalent "2NC 3s" (2) – Dual-channel equivalent 3 s "1NC+1NO" (3) – Dual-channel complementary "1NC+1NO 3s" (4) – Dual-channel complementary 3 s "2 OSSD 3s" (5) – Dual-channel SS equivalent 3 s "1NC" (6) – Single channel equivalent	Default: 0 = "Not used" Options: 0 = "Not used" 1 = "2NC" 2 = "2NC 3s" 3 = "1NC+1NO" 4 = "1NC+1NO 3s" 5 = "2 OSSD 3s" 6 = "1NC"		RW	Real
		53	LimSpd Mon Delay Limited Speed Monitoring Delay Defines the Safe Limited Speed Monitoring Delay between the SLS_In ON to OFF transition and the initiation of the Safe Limited Speed (SLS) or Safe Maximum Speed (SMS) monitoring.	Units: Secs Default: 0 Min/Max: 0 / 6553.5		RW	Real
		54	Enable SW Input Enable Switch Input Configuration for the Enabling Switch input (ESM_In). "2NC" (1) – Dual-channel equivalent "2NC 3s" (2) – Dual-channel equivalent 3 s "1NC+1NO" (3) – Dual-channel complementary "1NC+1NO 3s" (4) – Dual-channel complementary 3 s "2 OSSD 3s" (5) – Dual-channel SS equivalent 3 s "1NC" (6) – Single channel equivalent	Default: 0 = "Not used" Options: 0 = "Not used" 1 = "2NC" 2 = "2NC 3s" 3 = "1NC+1NO" 4 = "1NC+1NO 3s" 5 = "2 OSSD 3s" 6 = "1NC"		RW	Real
		55	Safe Speed Limit Safe Speed Limit Defines the speed limit that will be monitored in Safe Limited Speed (SLS) mode. Units are based on rotary or linear configuration defined by P29 [Fbk 1 Units].	Units: RPM mm/s Default: 0 Min/Max: 0 / 6553.5 RPM 0 / 6553.5 mm/s		RW	Real
		56	Speed Hysteresis Speed Hysteresis Provides hysteresis for SLS_Out output when Safe Limited Speed monitoring is active. 0% when P21 [Safety Mode] = 1, 2, 3, 4, 5, 6, 8, or 9 10...100% when P21 [Safety Mode] = 7 or 10	Units: % Default: 0 Min/Max: 0 / 100		RW	Real

File	Group	No.	Display Name Full Name Description	Values	Read-Write	Data Type
HOST GROUPS	Door Control	57	Door Out Type Door Output Type Defines the lock and unlock state for door control output (DC_Out). When Door Out Type equals power to release, DC_Out is OFF in the lock state and ON in the unlock state. When Door Out Type equals power to lock, DC_Out is ON in the lock state and OFF in the unlock state. The first and middle units of a multi-axis system must be configured as cascading (2).	Default: 0 = "Pwr to Rel" Options: 0 = "Pwr to Rel" 1 = "Pwr to Lock" 2 = "2 Ch Sourcing"	RW	Real
		58	DM Input Door Monitor Input Configuration for the Door Monitor input (DM_In). "2NC" (1) – Dual-channel equivalent "2NC 3s" (2) – Dual-channel equivalent 3 s "1NC+1NO" (3) – Dual-channel complementary "1NC+1NO 3s" (4) – Dual-channel complementary 3 s "2 OSSD 3s" (5) – Dual-channel SS equivalent 3 s "1NC" (6) – Single channel equivalent	Default: 0 = "Not used" Options: 0 = "Not used" 1 = "2NC" 2 = "2NC 3s" 3 = "1NC+1NO" 4 = "1NC+1NO 3s" 5 = "2 OSSD 3s" 6 = "1NC"	RW	Real
		59	Lock Mon Enable Lock Monitor Enable Lock Monitoring can only be enabled when the speed monitoring safety option is a single unit or as the first unit in a multi-axis system (P20 [Cascaded Config] = 0 or 1).	Default: 0 = "Disable" Options: 0 = "Disable" 1 = "Enable"	RW	Real
		60	Lock Mon Input Lock Monitor Input Configuration for the Lock Monitor input (LM_In). "2NC" (1) – Dual-channel equivalent "2NC 3s" (2) – Dual-channel equivalent 3 s "1NC+1NO" (3) – Dual-channel complementary "1NC+1NO 3s" (4) – Dual-channel complementary 3 s "2 OSSD 3s" (5) – Dual-channel SS equivalent "1NC" (6) – Single channel equivalent	Default: 0 = "Not used" Options: 0 = "Not used" 1 = "2NC" 2 = "2NC 3s" 3 = "1NC+1NO" 4 = "1NC+1NO 3s" 5 = "2 OSSD 3s" 6 = "1NC"	RW	Real

File	Group	No.	Display Name Full Name Description	Values		Read-Write	Data Type
HOST GROUPS	Max Speed	61	Max Speed Enable Maximum Speed Enable Enable Safe Maximum Speed Monitoring.	Default: 0 = "Disable" Options: 0 = "Disable" 1 = "Enable"		RW	Real
		62	Safe Max Speed Safe Maximum Speed Defines the maximum speed limit that will be tolerated if Safe Maximum Speed monitoring is enabled.	Units: RPM mm/s Default: 0 Min/Max: 0 / 65,535 RPM 0 / 65,535 mm/s		RW	Real
		63	Max Spd Stop Typ Maximum Speed Stop Type Defines the safe stop type that will be initiated in the event of a SMS Speed Fault. "Torque Off" (0) – Safe Torque Off With Standstill Checking "Safe Stp Typ" (1) – Safe Torque Off Without Standstill Checking	Default: 0 = "Torque Off" Options: 0 = "Torque Off" 1 = "Safe Stp Typ"		RW	Real
		64	Max Accel Enable Maximum Acceleration Enable Enable Safe Maximum Acceleration Monitoring.	Default: 0 = "Disable" Options: 0 = "Disable" 1 = "Enable"		RW	Real
		65	Safe Accel Limit Safe Acceleration Limit Defines the Safe Maximum Acceleration Limit, relative to encoder 1, for which the system is being monitored. Units are based on rotary or linear configuration defined by P29 [Fbk 1 Units].	Units: Rev/s ² mm/s ² Default: 0 Min/Max: 0 / 65,535 rev/s ² 0 / 65,535 mm/s ²		RW	Real
		66	Max Acc Stop Typ Maximum Acceleration Stop Type Defines the safe stop type that will be initiated in the event of an Acceleration Fault. "Torque Off" (0) – Safe Torque Off With Standstill Checking "Safe Stp Typ" (1) – Safe Torque Off Without Standstill Checking	Default: 0 = "Torque Off" Options: 0 = "Torque Off" 1 = "Safe Stp Typ"		RW	Real

File	Group	No.	Display Name	Values	Read-Write	Data Type
			Full Name Description			
HOST GROUPS	Faults	67	Fault Status			
			Fault Status Bit-encoded faults.			
			Options			
			Reserved			
			Reserved			
			Reserved			
			Fbk 2 V Flt			
			Fbk 1 V Flt			
			ESM Mon Flt			
			ESM In Flt			
			Lock Mon Flt			
			LM In Flt			
			DC Out Flt			
			Door Mon Flt			
			DM In Flt			
			Dir Flt			
			Accel Flt			
			SMS Spd Flt			
			SLS Spd Flt			
			SLS Out Flt			
			SLS In Flt			
			Mov in Stop			
			Stop Spd Flt			
			Decel Flt			
			SS Out Flt			
			SS In Flt			
			Dual Fbk Pos			
			Dual Fbk Spd			
			Fbk 2 Flt			
			Fbk 1 Flt			
			Reset PwrUp			
			MP Out Flt			
			Invalid Cfg			
			Critical Flt			
			Combined Flt			
			Default	0	0	0
			Bit	31	30	29
				28	27	26
				25	24	23
				22	21	20
				19	18	17
				16	15	14
				13	12	11
				10	9	8
				7	6	5
				4	3	2
				1	0	0
			Bit 0 "Combined Flt" – Combined Fault Status			
			Bit 1 "Critical Flt" – Critical Fault			
			Bit 2 "Invalid Cfg" – Invalid Configuration Fault			
			Bit 3 "MP Out Flt" – MP Out Fault			
			Bit 4 "Reset PwrUp" – Reset On at PwrUp Fault			
			Bit 5 "Fbk 1 Flt" – Feedback 1 Fault			
			Bit 6 "Fbk 2 Flt" – Feedback 2 Fault			
			Bit 7 "Dual Fbk Spd" – Dual FB Speed Fault			
			Bit 8 "Dual Fbk Pos" – Dual FB Position Fault			
			Bit 9 "SS In Flt" – SS_In Fault			
			Bit 10 "SS Out Flt" – SS_Out Fault			
			Bit 11 "Decel Flt" – Deceleration Fault			
			Bit 12 "Stop Spd Flt" – Stop Speed Fault			
			Bit 13 "Mov in Stop" – Motion After Stopped Fault			
			Bit 14 "SLS In Flt" – SLS_In Fault			
			Bit 15 "SLS Out Flt" – SLS_Out Fault			
			Bit 16 "SLS Spd Flt" – SLS_Speed Fault			
			Bit 17 "SMS Spd Flt" – SMS_Speed Fault			
			Bit 18 "Accel Flt" – Acceleration Fault			
			Bit 19 "Dir Flt" – Direction Fault			
			Bit 20 "DM In Flt" – DM_In Fault			
			Bit 21 "Door Mon Flt" – Door Monitoring Fault			
			Bit 22 "DC Out Flt" – DC_Out Fault			
			Bit 23 "LM In Flt" – LM_In Fault			
			Bit 24 "Lock Mon Flt" – Lock Monitoring Fault			
			Bit 25 "ESM In Flt" – ESM_In Fault			
			Bit 26 "ESM Mon Flt" – ESM Monitoring Fault			
			Bit 27 "Fbk 1 V Flt" – Encoder 1 Voltage Fault			
			Bit 28 "Fbk 2 V Flt" – Encoder 2 Voltage Fault			

File	Group	No.	Display Name Full Name Description	Values	Read-Write	Data Type																													
HOST GROUPS	Faults	68	Guard Status Guard Status																																
			Options	Reserved	Reserved	Reserved	Stop Cmd	SLS Cmd	Wait No Stop	Wait SS Cyc	Wait Reset	Reset In	ESM In Prog	ESM In	LM In	DM In Prog	DM In	DC Out	DC Lock	SDM In Prog	SMA In Prog	SMS In Prog	SLS Out	SLS In Prog	SLS Req	SLS In	SS Out	SS Stopped	SS Decel	SS In Prog	SS Req	SS In	MP Out	Config Lock	StatusOK
			Default	0	0	0	0	0	0	0	0	0	0	0	0	0	0	0	0	0	0	0	0	0	0	0	0	0	0	0	0	0	0	0	0
			Bit	31	30	29	28	27	26	25	24	23	22	21	20	19	18	17	16	15	14	13	12	11	10	9	8	7	6	5	4	3	2	1	0
			Bit 0 "Status OK" – 0 = Fault; 1 = OK Bit 1 "Config Lock" – Configuration_Lock: 0 = Unlock; 1 = Lock Bit 2 "MP Out" – MP_Out_Value: 0 = Off; 1 = On Bit 3 "SS In" – SS_In_Value: 0 = Off; 1 = On Bit 4 "SS Req" – SS_Request_Status: 0 = Inactive; 1 = Active Bit 5 "SS In Prog" – SS_In_Progress: 0 = Inactive; 1 = Active Bit 6 "SS Decel" – SS_Decelerating_Status: 0 = Inactive; 1 = Active Bit 7 "SS Stopped" – SS_Axis_Stopped_Status: 0 = Inactive; 1 = Active Bit 8 "SS Out" – SS_Output_Value: 0 = Off; 1 = On Bit 9 "SLS In" – SLS_In_Value: 0 = Off; 1 = On Bit 10 "SLS Req" – SLS_Request_Status: 0 = Inactive; 1 = Active Bit 11 "SLS In Prog" – SLS_In_Progress: 0 = Inactive; 1 = Active Bit 12 "SLS Out" – SLS_Output_Value: 0 = Off; 1 = On Bit 13 "SMS In Prog" – SMS_In_Progress: 0 = Inactive; 1 = Active Bit 14 "SMA In Prog" – SMA_In_Progress: 0 = Inactive; 1 = Active Bit 15 "SDM In Prog" – SDM_In_Progress: 0 = Inactive; 1 = Active Bit 16 "DC Lock" – DC_Lock_Status: 0 = Lock; 1 = Unlock Bit 17 "DC Out" – DC_Out_Value: 0 = Off; 1 = On Bit 18 "DM In" – DM_In_Value: 0 = Off; 1 = On Bit 19 "DM In Prog" – DM_In_Progress: 0 = Inactive; 1 = Active Bit 20 "LM In" – LM_In_Value: 0 = Off; 1 = On Bit 21 "ESM In" – ESM_In_Value: 0 = Off; 1 = On Bit 22 "ESM In Prog" – ESM_In_Progress: 0 = Inactive; 1 = Active Bit 23 "Reset In" – Reset_In_Value: 0 = Off; 1 = On Bit 24 "Wait Reset" – Waiting_for_SS_Reset: 0 = Inactive; 1 = Active Bit 25 "Wait SS Cyc" – Waiting_for_Cycle_SS_In: 0 = Inactive; 1 = Active Bit 26 "Wait No Stop" – Waiting_for_Stop_Request_Removal: 0 = Inactive; 1 = Active Bit 27 "SLS Cmd" – SLS_Command: 0 = Off; 1 = On Bit 28 "Stop Cmd" – Stop_Command: 0 = Off; 1 = On																																

File	Group	No.	Display Name Full Name Description	Values		Read-Write	Data Type
HOST GROUPS	Faults	70	Config Flt Code Configuration Fault Code. 0 = No Fault 1 = Password Required (Password Req) 2 = P21 [Safety Mode] value not legal based on P20 [Cascaded Config] value. 3 = P57 [Door Out Type] value not legal based on P20 [Cascaded Config] value. 4 = P46 [Stop Mon Delay] value not legal based on P45 [Safe Stop Type] value. 5 = P50 [Decel Ref Speed] value not legal based on P31 [Fbk 1 Resolution] value. 6 = P48 [Standstill Speed] value not legal based on P20 [Cascaded Config] value. 7 = P53 [LimSpd Mon Delay] value not legal based on P21 [Safety Mode] value. 8 = P55 [Safe Speed Limit] value not legal based on P21 [Safety Mode] and P31 [Fbk 1 Resolution] value. 9 = P56 [Speed Hysteresis] value not legal based on P21 [Safety Mode] value. 10 = P62 [Safe Max Speed] value not legal based on P31 [Fbk 1 Resolution] value. 11 = P42 [Direction Mon] value not legal based on P21 [Safety Mode] value. 12 = P59 [Lock Mon Enable] value not legal based on P21 [Safety Mode] value. 13 = P36 [Fbk 2 Resolution] value not legal based on P27 [Fbk Mode] value. 14 = P35 [Fbk 2 Polarity] value not legal based on P27 [Fbk Mode] value. 15 = P39 [Fbk Speed Ratio] value not legal based on P27 [Fbk Mode] value. 16 = P41 [Fbk Pos Tol] value not legal based on P27 [Fbk Mode] value. 17 = P40 [Fbk Speed Tol] value not legal based on P27 [Fbk Mode] value. 18 = P44 [Safe Stop In Typ] value not legal based on P21 [Safety Mode] value. 19 = P52 [Lim Spd In Typ] value not legal based on P21 [Safety Mode] value. 20 = P58 [DM Input Type] value not legal based on P20 [Cascaded Config] and P21 [Safety Mode] value. 21 = P54 [Enable SW In Typ] value not legal based on P21 [Safety Mode] value. 22 = P60 [Lock Mon In Type] value not legal based on P21 [Safety Mode] value and P59 [Lock Mon Enable] value. 23 = Illegal P20 [Cascaded Config] value. 24 = Illegal P22 [Reset Type] value. 25 = Reserved 26 = Illegal P45 [Safe Stop Type] value. 27 = Illegal P51 [Stop Decel Tol] value. 28 = Illegal P27 [Fbk Mode] value. 29 = Illegal P28 [Fbk 1 Type] value. 30 = Illegal P31 [Fbk 1 Resolution] value. 31 = Illegal P32 [Fbk1 Volt Mon] value. 32 = Illegal P37 [Fbk 2 Volt Mon] value. 33 = Illegal P24 [OverSpd Response] value. 34 = Reserved 35 = Reserved 36 = Unknown error (Unknown Err).	Default: NA	Options: 0...36	RW	Real

File	Group	No.	Display Name Full Name Description	Values		Read-Write	Data Type
HOST GROUPS	Faults	72	SS Out Mode Defines whether the SS_Out output is pulse-tested. If pulse-testing is turned off for any output, the SIL, Category, and PL rating is reduced for the entire safety system.	Default: 0 = "Pulse test" Options: 0 = "Pulse test" 1 = "No pulse test"		RW	Real
		73	SLS Out Mode Defines whether the SLS_Out output is pulse-tested. If pulse-testing is turned off for any output, the SIL, Category, and PL rating is reduced for the entire safety system.	Default: 0 = "Pulse test" Options: 0 = "Pulse test" 1 = "No pulse test"		RW	Real
		74	Door Out Mode Defines whether the DC_Out output is pulse-tested. If pulse-testing is turned off for any output, the SIL, Category, and PL rating is reduced for the entire safety system.	Default: 0 = "Pulse test" Options: 0 = "Pulse test" 1 = "No pulse test"		RW	Real

Numerics

2 Channel Sourcing 68

efesotomasyon.com

A

access

hazardous area 86

additional resources 13

automatic reset 48

SLS Reset 77

SS reset 67

C

cascaded config 47, 97

cascaded connections 41, 43, 45

Cat 4 11, 15

performance definition 16

certification

Cat 4 11, 15

ISO 13849-1 15

PLe 11, 15

SIL CL3 11, 15

certifications 162

commissioning the system 124-127

commutation 22

configuration

confirm 127

example 1 129

example 2 139

lock 121

lock bit 122, 127

signature. See Signature ID.

specification 125

configure

parameters 126

D

DC_Out output 44

wiring 44, 45

deceleration monitoring 63, 65, 66

discrepancy checking 56

encoders 55

DM_In input 38

documentation

additional resources 13

Door Control 67-68

Door Control output

fault conditions 68

Door Control wiring 44

Door Monitoring Fault 89

DriveExecutive software

version 27

DriveExplorer software

version 27

dual channel operation 35

dual encoder

configurations 55

resolution 54

dual feedback position discrepancy

tolerance

definition 56

Dual Feedback Speed Discrepancy

Tolerance

definition 57

Dual Feedback Speed Ratio

definition 55

E

edit the configuration 126, 128

emergency shutdown systems 15

EN 60204-1 17

EN 61508 18

SIL CL3 certification 15

EN 61508-5-2 162

EN 61800-5-2

SIL CL3 certification 15

EN 62061 18

encoder

compatible 33

diagnostics 21

resolution 49

single encoder 21

specifications 162

ESM_In input 39, 83

European Norm

definition 12

F

failure

contact information 22

fault

Door Monitoring 89

fault codes

configuration faults 159

Fault While Stopping Faults 153

input 152

nonrecoverable 152

output 152

recovery 152

Safe State Faults 153

Stop Category Faults 154

fault history queue 152
fault recovery 152
Fault While Stopping Faults 155
features 26
feedback
 device types 54
 fault 58
 parameters 58
 polarity 54
 resolution 54
 type 54
 voltage monitor range 57
feedback monitoring 54-57

G

Guard Status attributes 156

H

HIM module 27
hold last state
 SLS_Out output 92

I

I/O Diagnostic Status attributes 158
input faults 152
inputs 35
installing 31
ISO 13849-1 15, 16, 18, 162

J

J2 jumper 30

L

LED Indicators 151
LM_In input 39
Lock Monitoring 25, 69
Lock Monitoring wiring 44
lock state 121

M

manual monitored reset 48
 SLS Reset 77
 SS Reset 67
manual reset 48
 SLS Reset 77
 SS Reset 67
Max Stop Time
 definition 61

multi-axis
 configurations 97-98
 connections 110, 111
 wiring 41, 43

O

output faults 152
output test pulse 21
outputs 41
OverSpd Response 49

P

parameter list
 all parameters 164-??
 feedback 58
 general 53
 Max Speed and Direction Monitoring 120
 Safe Limited Speed 78
 Safe Limited Speed Status Only 93
 Safe Stop 69
 Safe Stop With Door Monitoring 73
 Slave, Safe Limited Speed 104
 Slave, Safe Limited Speed Status Only 107
 Slave, Safe Stop 99
 SLS With Door Monitoring 82
 SLS With Door Monitoring and Enabling Switch Monitoring 89
 SLS With Enabling Switch Monitoring 84

parameters
 complete list 164
 configure 126
 edit 126, 128
 groups 163

password
 change 122
 new 122
 reset 122

PFD
 data 19
 definition 12, 18

PFH
 data 19
 definition 12, 18

pinouts 26, 32

PL 18
 definition 12

PLe 11, 15, 162

polarity 54
power supply 29
Power to Lock 68
Power to Release 68

probability of failure on demand 12
probability of failure per hour 12
proof tests 18
pulse test outputs 35

R

recover from fault 152
reset
 device configuration 123
 password 122
 See also SS Reset, SLS Reset, or Reset Type.
Reset input wiring
 Reset_In input 40
Reset Type 48
Reset_In input 77
risk assessment 29, 125

S

Safe Accel Limit
 See Safe Maximum Acceleration Limit.
Safe Direction Monitoring 118
 negative 119
 overview 25
 positive 119
Safe Limited Speed mode 75
Safe Limited Speed Monitoring Delay 75, 76, 77, 84, 86, 91
Safe Limited Speed Monitoring Inactive 88
Safe Limited Speed Reset
 See SLS Reset.
Safe Limited Speed Status Only mode 91
Safe Limited Speed with Door Monitoring and Enabling Switch Monitoring mode 86
Safe Limited Speed with Door Monitoring mode 81
Safe Limited Speed with Enabling Switch Monitoring mode 83
Safe Max Speed 113
Safe Maximum Acceleration Limit 116
Safe Maximum Acceleration Monitoring 116-118
 overview 25
Safe Maximum Speed Monitoring 113-115
 overview 25
Safe Speed Limit 75, 87, 92
Safe State
 definition 19
Safe State Faults 155
Safe Stop 1 63
Safe Stop 2 63
Safe Stop mode 61
Safe Stop Reset
 See SS Reset.
Safe Stop Types 62-64
Safe Stop with Door Monitoring mode 72
Safe Torque Off with Standstill Checking 62
Safe Torque Off without Standstill Checking 64
safety
 certification, TÜV Rheinland 15
 enable jumper 30
 functions overview 23
 information 29
 lock 121
 mode, slave combinations 111
 modes 24, 48
 power supply 29
 ratings 20
 reaction time 20, 49
shutdown, EDS 15
Signature ID 121, 126, 127
SIL CL3 11, 15, 162
 certification, user responsibilities 16
single encoder configurations 54
single-channel operation 35
Slave, Safe Limited Speed mode 104
Slave, Safe Limited Speed Status Only mode 107
Slave, Safe Stop mode 98
SLS Reset 48, 77, 84
 automatic 76, 77
 manual 77
 manual monitored 77
 SLS with Door Monitoring and Enabling Switch Monitoring mode 89
 SLS with Door Monitoring mode 82
SLS_In input 38, 77
 configuring drive 79
 SLS Reset 77, 84
SLS_Out output 42
 hold last state 92
specifications
 encoder 162
 general 161
speed hysteresis 92

speed resolution 49

speed resolution accuracy

example 49

linear 52

rotary 50

SS Reset 48, 66-67

SLS with Door Monitoring and Enabling
Switch Monitoring mode 89

SS_In input 38

SS_Out output 41

Standstill Position Tolerance

definition 65

Standstill Speed

definition 65

status attributes 156

status indicators 151

stop category

definitions 17

Stop Category Faults 155

Stop Delay

See Max Stop Time.

Stop Monitoring Delay

definition 61

T

terminal screws

connections 32

strip length 32

torque 32

timing diagram

Safe Limited Speed 76, 81, 87

Safe Limited Speed Status Only 91

Safe Stop 1 63

Safe Stop 2 64

Safe Torque Off with Standstill Checking
62

Safe Torque Off Without Standstill
Checking 64

V

validation

third-party 127

verify

configuration 127

lock status 127

Signature ID 127

W

wiring

DC_Out output 44, 45

DM_In input 44

LM_In input 44

multi-axis connections 41, 43

safety input examples 37

wiring example

Safe Limited Speed mode 80

Safe Limited Speed Status Only mode 94,
96

Safe Stop mode 71

Safe Stop with Door Monitoring mode 74

Slave, Safe Limited Speed 105-106

Slave, Safe Limited Speed Status Only
mode 108-109

Slave, Safe Stop mode 101-103

SLS with Door Monitoring and Enabling
Switch Monitoring mode 90

SLS with Door Monitoring mode 83

SLS with Enabling Switch Monitoring
mode 85

Rockwell Automation Support

Rockwell Automation provides technical information on the Web to assist you in using its products. At <http://www.rockwellautomation.com/support/>, you can find technical manuals, a knowledge base of FAQs, technical and application notes, sample code and links to software service packs, and a MySupport feature that you can customize to make the best use of these tools.

For an additional level of technical phone support for installation, configuration, and troubleshooting, we offer TechConnect support programs. For more information, contact your local distributor or Rockwell Automation representative, or visit <http://www.rockwellautomation.com/support/>.

Installation Assistance

If you experience a problem within the first 24 hours of installation, review the information that is contained in this manual. You can contact Customer Support for initial help in getting your product up and running.

United States or Canada	1.440.646.3434
Outside United States or Canada	Use the Worldwide Locator at http://www.rockwellautomation.com/support/americas/phone_en.html , or contact your local Rockwell Automation representative.

New Product Satisfaction Return

Rockwell Automation tests all of its products to ensure that they are fully operational when shipped from the manufacturing facility. However, if your product is not functioning and needs to be returned, follow these procedures.

United States	Contact your distributor. You must provide a Customer Support case number (call the phone number above to obtain one) to your distributor to complete the return process.
Outside United States	Please contact your local Rockwell Automation representative for the return procedure.

Documentation Feedback

Your comments will help us serve your documentation needs better. If you have any suggestions on how to improve this document, complete this form, publication [RA-DU002](#), available at <http://www.rockwellautomation.com/literature/>.

www.rockwellautomation.com

Power, Control and Information Solutions Headquarters

Americas: Rockwell Automation, 1201 South Second Street, Milwaukee, WI 53204 USA, Tel: (1) 414.382.2000, Fax: (1) 414.382.4444

Europe/Middle East/Africa: Rockwell Automation, Vorstlaan/Boulevard du Souverain 36, 1170 Brussels, Belgium, Tel: (32) 2 663 0600, Fax: (32) 2 663 0640

Asia Pacific: Rockwell Automation, Level 14, Core F, Cyberport 3, 100 Cyberport Road, Hong Kong, Tel: (852) 2887 4788, Fax: (852) 2508 1846