

PowerFlex® 4 and 40

Technical Data

efesotomasyon.com



ADJUSTABLE FREQUENCY AC DRIVES

LISTEN.
THINK.
SOLVE.®

 Allen-Bradley • Rockwell Software

**Rockwell
Automation**

Product Overview

Providing users with powerful motor speed control in a compact, space saving design, the Allen-Bradley® PowerFlex® 4 and 40 AC drives are the smallest and most cost-effective members of the PowerFlex® family of drives. Available in power ratings from 0.2 to 11 kW (0.25 to 15 HP) and in voltage classes of 120, 240, 480 and 600 volts, PowerFlex 4 and 40 are designed to meet global OEM and end-user demands for flexibility, space savings, ease of use and are cost-effective alternatives for speed control of applications such as machine tools, fans, pumps and conveyors and material handling systems



Table of Contents

Description	Page
Packaging and Mounting	3
Start Up, Programming and Operation	3
Optimized Performance	4
Sensorless Vector Performance	4
Sensorless Vector Control	4
Performance	4
I/O	5
Communications	5
Versatile Programming and Network Solutions	6
PC Programming Software	6
Catalog Number Explanation	8
Product Selection	9
User Installed Options	10
Installation Considerations	13
Control Wiring	14
Specifications	18
Parameter Descriptions	21
Product Dimensions	24
PowerFlex 4 and 40 Configured Drives	31

efesotomasyon.com

Reference Materials

For additional PowerFlex 4 and 40 data and general drive information, refer to the following publications:

Title	Publication	Available Online at . . .
PowerFlex 4 User Manual	22A-UM001...	www.rockwellautomation.com/literature
PowerFlex 40 User Manual	22B-UM001...	
Wiring and Grounding Guidelines for PWM AC Drives	DRIVES-IN001...	
Preventive Maintenance of Industrial Control and Drive System Equipment	DRIVES-TD001...	
Safety Guidelines for the Application, Installation and Maintenance of Solid State Control	SGI-1.1	

For other information, contact Allen-Bradley Drives Technical Support:

Title	Online at . . .
Allen-Bradley Drives Technical Support	www.ab.com/support/abdrives

Shaded areas are applicable to PowerFlex 40 only.

Packaging and Mounting

- Installation can be a virtual snap using the **DIN rail mounting** feature on A and B frame drives. Panel mounting is also available, providing added flexibility.
- **Flange mount** drives are available to reduce overall enclosure size.
- **Zero Stacking™** is allowable for ambient temperatures up to 40°C, saving valuable panel space. 50°C ambient temperatures are permitted with minimal spacing between drives.
- **Integral filtering** is available on all 230V single phase ratings, providing a cost-effective means of meeting EN55011, Class A and B EMC requirements. External filters provide compliance to Class A and B requirements for all PowerFlex 4 and 40 ratings.
- An optional **IP30, NEMA/UL Type 1 conduit box** is easily adapted to the standard IP20 (NEMA Type Open) product, providing increased environmental ratings.
- **IP66, NEMA/UL Type 4X/12 (Indoor)** for mounting directly in the product environment. Listed by UL to resist dust, dirt, etc. and survive high pressure water spray. Also certified by NSF to ensure conformity with international food equipment standards.



efesotomasyon.com

Start Up, Programming and Operation

- An **integral keypad** provides out of the box operation using the local potentiometer and control keys.
- The 10 most common application parameters are contained in the **Basic Program Group**, making programming fast and easy.
- The **programming keys** have the same function as all other PowerFlex drives, so if you can program one PowerFlex drive, you can program them all.
- **4 digit display** with 10 additional LED indicators provides an intuitive display of drive status and information.
- Integral **RS-485 communications** can be used for programming from a PC. It can also be used in a multi-drop network configuration. A serial converter module provides connectivity to any controller with a DF1 port.
- A **NEMA/UL Type 4X remote** and **NEMA/UL Type 1 hand-held LCD keypad** provide additional programming and control flexibility, both featuring the popular CopyCat function.



Optimized Performance

- **Removable MOV** to ground provides trouble-free operation when used on ungrounded distribution systems.
- A **relay pre-charge** limits inrush current.
- **Integral brake transistor**, available on all ratings (except no brake version), provides dynamic braking capability with simple low cost brake resistors.
- DIP switch settable **24V DC sink or source control** for control wiring flexibility.
- 150% overload for 60 seconds or 200% overload for 3 seconds provides **robust overload protection**.
- **Adjustable PWM frequency up to 16 kHz** ensures quiet operation.



Sensorless Vector Performance

PowerFlex 4

- Drive automatically provides auto boost (IR compensation) and slip compensation.
- Provides excellent speed regulation and high levels of torque across the entire speed range of the drive, and improved speed regulation even as loading increases.

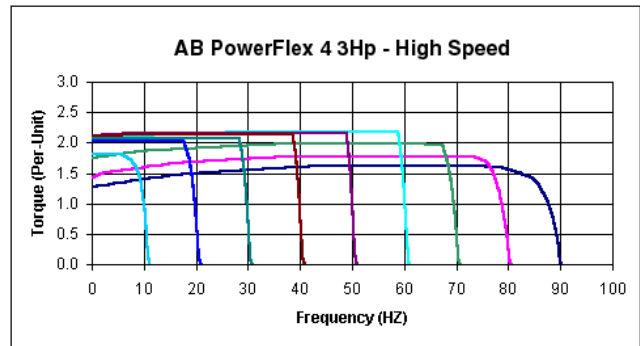

Sensorless Vector Control

PowerFlex 40

- Sensorless Vector Control provides exceptional speed regulation and very high levels of torque across the entire speed range of the drive.
- The Autotune feature allows the PowerFlex 40 to adapt to individual motor characteristics.

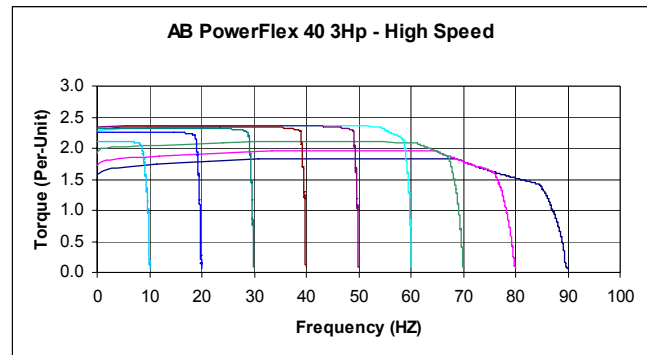

Performance

- This graph depicts the ability of a PowerFlex 40 drive to accelerate into at least 150% load. A PowerFlex 4 will perform similarly, but with a slightly higher acceleration time.
- At 100% motor load, the drive will run the motor at synchronous speed.
- Excellent current regulation.
- Linear acceleration.
- Best in class digital input response time and repeatability.

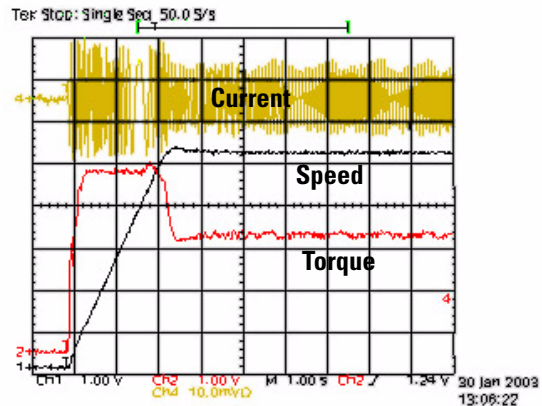

Performance

- **Sensorless Vector Control** develops high torque over a wide speed range and adapts to individual motor characteristics.
- **Variable PWM** allows the drive to output more current at low frequencies.
- Integral **PID** functionality enhances application flexibility.
- **Timer, Counter, Basic Logic and StepLogic™ functions** can reduce hardware design costs and simplify control schemes.
 - **Timer function:** Relay or opto outputs controlled by drive performing timer function. Timer is initiated by activating a digital input programmed as “Timer Start.”
 - **Counter function:** Relay or opto outputs controlled by drive performing counter function. Counter function is activated by a digital input programmed as “Counter Input.”
 - **Basic Logic:** Relay or opto outputs controlled by status of digital inputs programmed as “Logic Inputs.” Performs basic Boolean logic.
 - **StepLogic:** Logic-based steps using preset speed settings. Each step can be programmed for a specific speed, direction and accel/decel profile. Drive outputs can be used to indicate which step is being performed.



I/O

- **Two (2) Analog Inputs** (one unipolar and one bipolar) are independently isolated from the rest of the drive I/O. These inputs can be toggled between via a digital input.
- **Three (3) fixed and four (4) fully programmable Digital Inputs** provide application versatility.
- **One (1) Analog Output** is DIP switch selectable for either 0-10V or 0-20mA. This scalable, 10-bit output is suitable for metering or as a speed reference for another drive.
- **Two (2) Opto Outputs** and **one (1) form C relay output** can be used to indicate various drive, motor or logic conditions.

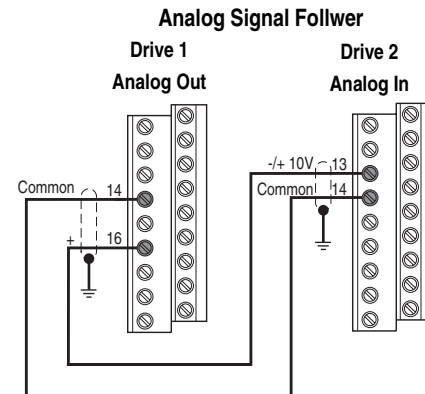

Communications

- Integral communication cards such as DeviceNet™, EtherNet/IP™, PROFIBUS™ DP, LonWorks® and, ControlNet™ can improve machine performance.
- The DSI Wireless Interface Module (WIM) provides a wireless communication interface between a Pocket PC, laptop computer or desktop computer equipped with Bluetooth® wireless technology, and any Allen-Bradley® product supporting the DSI™ protocol.
- Field installed option allows for future addition of stand-alone drives to a network.
- Online EDS file creation with RS NetWorx™ providing ease of set-up on a network.



Versatile Programming and Network Solutions

- PowerFlex 4 and PowerFlex 40 are compatible with any device that acts as a RTU Master and supports standard 03 and 06 RTU commands.
- A network can be configured using PowerFlex 40 drives with optional communication cards for high performance and flexible configuration capabilities.
 - BACnet
 - ControlNet
 - DeviceNet
 - EtherNet/IP
 - LonWorks
 - PROFIBUS DP
- A multi-drive solution can be reached using a single PowerFlex 40 DeviceNet option, with the ability for up to five (5) drives to reside on one (1) node.
- Integral RS485 communications enable the drives to be used in a multi-drop network configuration. A serial converter module (SCM) provides connectivity to any controller with a DF1 port. The SCM can be eliminated if the controller acts as a RTU Master.

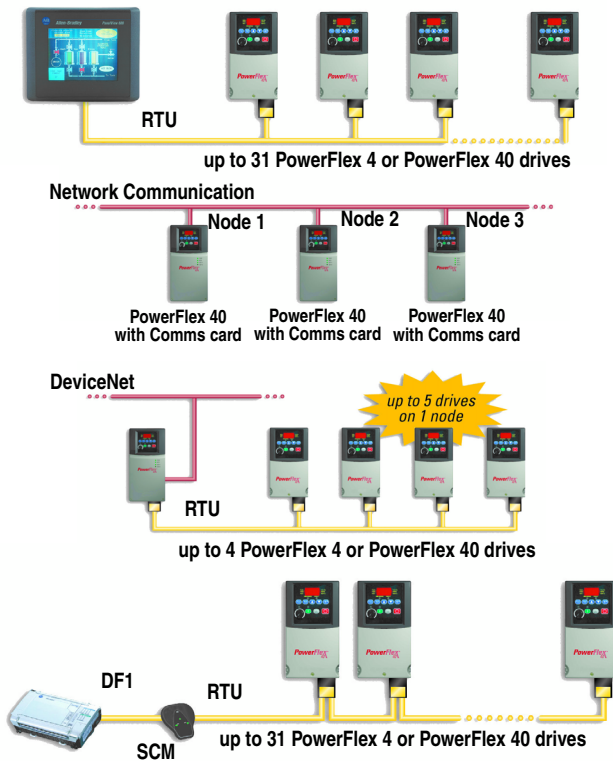

PC Programming Software

Through the use of a Serial Converter Module and DriveExplorer™ or DriveTools™ SP software, programming can be greatly simplified.

DriveExplorer Software

- View and modify drive and adapter parameters in a method similar to the file management capability of Microsoft Windows Explorer.
- Operate the drive via an on-screen Control Bar, which is a tool that allows you to start, stop, and change the speed reference of the drive.
- Save, restore and print parameter information.
- Compare current parameters with factory defaults or previously saved parameter values.
- Edit, upload and download parameters.

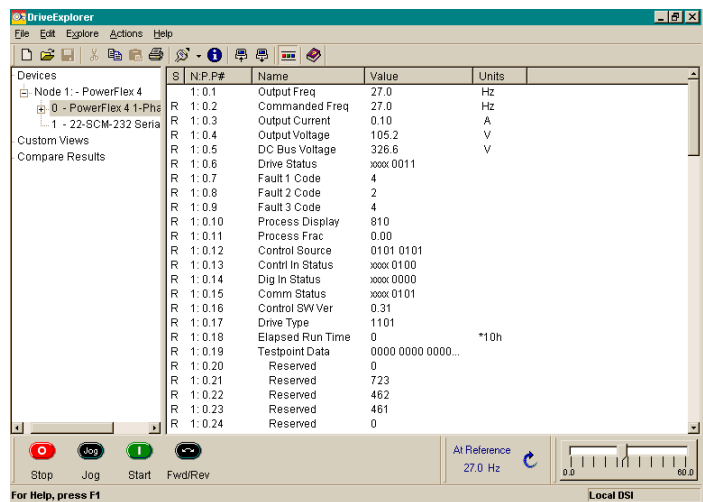

DriveTools SP Software

- Online and offline programming capability
- In-grid and dialog-based parameter editing
- Immediate visual indication of drive and communication status when viewing online drive
- Integrated HTML Help architecture

Use the chart below to assist in determining which product is most appropriate for an application.

	PowerFlex® 4	PowerFlex® 40
Feature		
Catalog Reference	22A...	22B...
Maximum (kW)HP Rating/Input Voltage	(1.1) 1.5 HP/115V, 1ø (2.2) 3 HP/230V, 1ø (3.7) 5 HP/230V, 3ø (3.7) 5 HP/460V, 3ø	(1.1) 1.5 HP/115V, 1ø (2.2) 3 HP/230V, 1ø (7.5) 10 HP/230V, 3ø (11.0) 15 HP/460V, 3ø (11.0) 15 HP/600V, 3ø
Overload Capacity	150% for 60 seconds 200% for 3 seconds	150% for 60 seconds 200% for 3 seconds
IP30, NEMA/UL Type 1 Option	●	●
IP66, NEMA/UL Type 4X/12 (Indoor)		● ②
EMC Filtering	Internal - 1ø, 230V External - All 1ø, 115V and 3ø Ratings	Internal - 1ø, 230V External - All 1ø, 115V and 3ø Ratings
DIN Rail Mounting Standard	●	● (Through 5 HP)
Integral Keypad with Speed Pot	●	●
Keypad - Remote LCD	●	●
Keypad CopyCat Function	●	●
Control Type	V/Hz	Sensorless Vector & V/Hz
Internal DB Transistor	● Not available on no brake models.	●
Preset Speeds	4	8
Carrier Frequency	2-16 kHz	2-16 kHz
Skip Frequency		●
Process Control Loop		● (PID)
StepLogic Functionality		●
Timer/Counter Functions		●
Control Voltage	24V sink/source	24V sink/source
Discrete Inputs	3 fixed for START/STOP/REV 2 fully programmable	3 fixed for START/STOP/REV 4 fully programmable
Analog Input - Unipolar	1 (0-10V or 4-20 mA)	2 (0-10V and 4-20 mA)
Analog Input - Bipolar		1 (+/- 10V) ③
Analog Response	2 Hz (500 ms)	100 Hz (10 ms)
Relay Output	1 - N.O./N.C. dry contact	1 - N.O./N.C. dry contact
Digital/Optocoupler Output		2
Analog Output		● (0-10V or 4-20 mA)
Integral RS485	●	●
RS232 (Requires use of Serial Converter Module)	●	●
BACnet	● ①	●
ControlNet	● ①	●
DeviceNet	● ①	●
EtherNet/IP	● ①	●
LonWorks	● ①	●
PROFIBUS DP	● ①	●

① With 22-XCOMM-DC-BASE External mounting kit.

② Frame B only.

③ When using bipolar input, the 0-10V unipolar input cannot be used.

Catalog Number Explanation

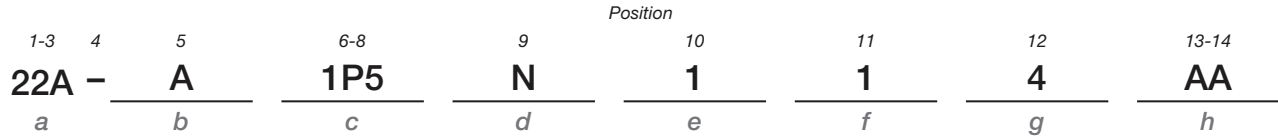

a

Drive	
Code	Type
22A	PowerFlex 4
22B	PowerFlex 40

b

Voltage Rating		
Code	Voltage	Ph.
V	120V ac	1
A	240V ac	1
B	240V ac	3
D	480V ac	3
E	600V ac	3

c1

Rating		
100-120V Single-Phase Input		
Code	Amps	kW (Hp)
2P3	2.3	0.4 (0.5)
5P0	5.0	0.75 (1.0)
6P0	6.0	1.1 (1.5)

c2

Rating		
200-240V Single-Phase Input		
Code	Amps	kW (Hp)
2P3	2.3	0.4 (0.5)
5P0	5.0	0.75 (1.0)
8P0	8.0	1.5 (2.0)
012	12	2.2 (3.0)

c3

Rating		
200-240V Three-Phase Input		
Code	Amps	kW (Hp)
2P3	2.3	0.4 (0.5)
5P0	5.0	0.75 (1.0)
8P0	8.0	1.5 (2.0)
012	12	2.2 (3.0)
017	17.5	3.7 (5.0)
024	24	5.5 (7.5)
033	33	7.5 (10)

c4

Rating		
380-480V Three-Phase Input		
Code	Amps	kW (Hp)
1P4	1.4	0.4 (0.5)
2P3	2.3	0.75 (1.0)
4P0	4.0	1.5 (2.0)
6P0	6.0	2.2 (3.0)
010	10.5	4.0 (5.0)
012	12	5.5 (7.5)
017	17	7.5 (10)
024	24	11 (15)

c5

Rating		
460-600V Three-Phase Input		
Code	Amps	kW (Hp)
1P7	1.7	0.75 (1.0)
3P0	3.0	1.5 (2.0)
4P2	4.2	2.2 (3.0)
6P6	6.6	4.0 (5.0)
9P9	9.9	5.5 (7.5)
012	12	7.5 (10)
019	19	11 (15)

d

Enclosure	
Code	Enclosure
C	IP66, NEMA/UL Type 4X *
F	Flange Mount - IP20, NEMA/UL Type Open
H	Replacement Plate Drive - IP20, NEMA/UL Type Open Contact factory for ordering information.
N	Panel Mount - IP20, NEMA/UL Type Open

* Check availability before ordering.

e

HIM	
Code	Interface Module
1	Fixed Keypad

f

Emission Class	
Code	Rating
0	Not Filtered
1	Filtered

g

Brake IGBT	
Code	Description
3	Without Brake
4	With Brake

h

Optional	
Code	Purpose
AA through ZZ	Reserved for custom firmware

Product Selection

Drive Ratings			PowerFlex 4			IP 20 Flange Mount ②	PowerFlex 40			IP 66, UL Type 4X Panel Mount	IP 20 Flange Mount ②
Input Voltage	kW	HP	Output Current	Catalog Number	Frame Size	Catalog Number	Output Current	Catalog Number	Frame Size	Catalog Number	Catalog Number
120V 50/60 Hz 1-Phase No Filter	0.2	0.25	1.5A	22A-V1P5N104	A	22A-V1P5F104	—	—	—	—	—
	0.4	0.5	2.3A	22A-V2P3N104	A	22A-V2P3F104	2.3A	22B-V2P3N104	B	22B-V2P3C104	22B-V2P3F104
	0.75	1.0	4.5A	22A-V4P5N104	B	22A-V4P5F104	5.0A	22B-V5P0N104	B	22B-V5P0C104	22B-V5P0F104
	1.1	1.5	6.0A	22A-V6P0N104	B	22A-V6P0F104	6.0A	22B-V6P0N104	B	22B-V6P0C104	22B-V6P0F104
240V 50/60 Hz 1-Phase NO BRAKE No Filter	0.2	0.25	1.4A	22A-A1P4N103	A	—	—	—	—	—	—
	0.4	0.5	2.1A	22A-A2P1N103	A	—	—	—	—	—	—
	0.75	1.0	3.6A	22A-A3P6N103	A	—	—	—	—	—	—
	1.5	2.0	6.8A	22A-A6P8N103	B	—	—	—	—	—	—
240V 50/60 Hz 1-Phase NO BRAKE With Integral “S Type” EMC Filter ①	0.2	0.25	1.4A	22A-A1P4N113	A	—	—	—	—	—	—
	0.4	0.5	2.1A	22A-A2P1N113	A	—	—	—	—	—	—
	0.75	1.0	3.6A	22A-A3P6N113	A	—	—	—	—	—	—
	1.5	2.0	6.8A	22A-A6P8N113	B	—	—	—	—	—	—
240V 50/60 Hz 1-Phase With Integral “S Type” EMC Filter ①	0.2	0.25	1.5A	22A-A1P5N114	A	—	—	—	—	—	—
	0.4	0.5	2.3A	22A-A2P3N114	A	—	2.3A	22B-A2P3N114	B	—	—
	0.75	1.0	4.5A	22A-A4P5N114	A	—	5.0A	22B-A5P0N114	B	—	—
	1.5	2.0	8.0A	22A-A8P0N114	B	—	8.0A	22B-A8P0N114	B	—	—
240V 50/60 Hz 1-Phase No Filter	2.2	3.0	—	—	—	—	12.0A	22B-A012N114	C	—	—
	0.2	0.25	1.5A	22A-A1P5N104	A	22A-A1P5F104	—	—	—	—	—
	0.4	0.5	2.3A	22A-A2P3N104	A	22A-A2P3F104	2.3A	22B-A2P3N104	B	22B-A2P3C104	22B-A2P3F104
	0.75	1.0	4.5A	22A-A4P5N104	A	22A-A4P5F104	5.0A	22B-A5P0N104	B	22B-A5P0C104	22B-A5P0F104
	1.5	2.0	8.0A	22A-A8P0N104	B	22A-A8P0F104	8.0A	22B-A8P0N104	B	22B-A8P0C104	22B-A8P0F104
240V 50/60 Hz 3-Phase No Filter	2.2	3.0	—	—	—	—	12.0A	22B-A012N104	C	—	22B-A012F104
	0.2	0.25	1.5A	22A-B1P5N104	A	22A-B1P5F104	—	—	—	—	—
	0.4	0.5	2.3A	22A-B2P3N104	A	22A-B2P3F104	2.3A	22B-B2P3N104	B	22B-B2P3C104	22B-B2P3F104
	0.75	1.0	4.5A	22A-B4P5N104	A	22A-B4P5F104	5.0A	22B-B5P0N104	B	22B-B5P0C104	22B-B5P0F104
	1.5	2.0	8.0A	22A-B8P0N104	A	22A-B8P0F104	8.0A	22B-B8P0N104	B	22B-B8P0C104	22B-B8P0F104
	2.2	3.0	12.0A	22A-B012N104	B	22A-B012F104	12.0A	22B-B012N104	B	22B-B012C104	22B-B012F104
	3.7	5.0	17.5A	22A-B017N104	B	22A-B017F104	17.5A	22B-B017N104	B	22B-B017C104	22B-B017F104
480V 50/60 Hz 3-Phase No Filter	5.5	7.5	—	—	—	—	24.0A	22B-B024N104	C	—	22B-B024F104
	7.5	10.0	—	—	—	—	33.0A	22B-B033N104	C	—	22B-B033F104
	0.4	0.5	1.4A	22A-D1P4N104	A	22A-D1P4F104	1.4A	22B-D1P4N104	B	22B-D1P4C104	22B-D1P4F104
	0.75	1.0	2.3A	22A-D2P3N104	A	22A-D2P3F104	2.3A	22B-D2P3N104	B	22B-D2P3C104	22B-D2P3F104
	1.5	2.0	4.0A	22A-D4P0N104	A	22A-D4P0F104	4.0A	22B-D4P0N104	B	22B-D4P0C104	22B-D4P0F104
	2.2	3.0	6.0A	22A-D6P0N104	B	22A-D6P0F104	6.0A	22B-D6P0N104	B	22B-D6P0C104	22B-D6P0F104
	3.7	5.0	8.7A	22A-D8P7N104	B	22A-D8P7F104	—	—	—	—	—
	4.0	5.0	—	—	—	—	10.5A	22B-D010N104	B	22B-D010C104	22B-D010F104
	5.5	7.5	—	—	—	—	12.0A	22B-D012N104	C	—	22B-D012F104
	7.5	10.0	—	—	—	—	17.0A	22B-D017N104	C	—	22B-D017F104
	11.0	15.0	—	—	—	—	24.0A	22B-D024N104	C	—	22B-D024F104 ③
600V 50/60 Hz 3-Phase No Filter	0.75	1.0	—	—	—	—	1.7A	22B-E1P7N104	B	22B-E1P7C104	22B-E1P7F104
	1.5	2.0	—	—	—	—	3.0A	22B-E3P0N104	B	22B-E3P0C104	22B-E3P0F104
	2.2	3.0	—	—	—	—	4.2A	22B-E4P2N104	B	22B-E4P2C104	22B-E4P2F104
	4.0	5.0	—	—	—	—	6.6A	22B-E6P6N104	B	22B-E6P6C104	22B-E6P6F104
	5.5	7.5	—	—	—	—	9.9A	22B-E9P9N104	C	—	22B-E9P9F104
	7.5	10.0	—	—	—	—	12.0A	22B-E012N104	C	—	22B-E012F104
	11.0	15.0	—	—	—	—	19.0A	22B-E019N104	C	—	22B-E019F104

- ① This filter is suitable for use with a cable length of at least 10 meters for Class A and 1 meter for Class B environments.
- ② Meets IP40/54/65 (NEMA 1/12/4/4X) when installed in an enclosure of like rating.
- ③ Requires use of external DC Bus Inductor or AC Line Reactor.

Shaded areas are applicable to PowerFlex 40 only.

User Installed Options

IP30/NEMA 1/UL Type 1 Conversion Kit

Item	Description	Drive Frame	PowerFlex 4	PowerFlex 40
			Catalog Number ❶	Catalog Number ❶
IP30/NEMA 1/UL Type 1 Kit	Field installed kit. Converts drive to IP30/NEMA 1/UL Type 1 enclosure. Includes conduit box with mounting screws and plastic top panel.	A	22-JBAA	–
		B	22-JBAB	22-JBAB
		C	–	22-JBAC
IP30/NEMA 1/UL Type 1 Kit with Communication Option	Field installed kit. Converts drive to IP30/NEMA 1/UL Type 1 enclosure. Includes communication option conduit box with mounting screws and plastic top panel.	B	–	22-JBCB
		C	–	22-JBCC

Human Interface Module Option Kits and Accessories

Item	Description	Catalog Number ❶
Remote Human Interface Modules (HIMs)	LCD Display, Remote Panel Mount, Digital Speed Control, CopyCat capable, IP66 (NEMA Type 4X/12) indoor use only. Includes 2.0 meter cable.	22-HIM-C2S
	LCD Display, Remote Handheld, Digital Speed Control, Full Numeric Keypad, CopyCat capable, IP30 (NEMA Type 1). Includes 1.0 meter cable. Can be panel mounted with optional Bezel Kit.	22-HIM-A3
	Remote Handheld, Wireless Interface Module with <i>Bluetooth</i> ® technology, IP30 (NEMA Type 1). Panel Mount with optional Bezel Kit.	22-WIM-N1
	Remote Panel Mount, Wireless Interface Module with <i>Bluetooth</i> ® technology, IP66 (NEMA Type 4X/12) indoor use only.	22-WIM-N4S
Bezel Kit	Panel Mount for LCD Display, Remote Handheld unit, IP30 (NEMA Type 1). Includes a 22-RJ45CBL-C20 cable.	22-HIM-B1
DSI HIM Cable	DSI HIM Cable (DSI HIM to RJ45 cable)	
	1.0 Meter (3.3 Feet) 2.9 Meter (9.51 Feet)	22-HIM-H10 22-HIM-H30

Communication Option Kits

Item	Description	Catalog Number ❶
Serial Converter Module (RS485 to RS232)	Provides serial communication via DF1 protocol for use with DriveExplorer™ and DriveExecutive™ software. Smart Self-powered Serial Converter (RS-232) includes: DSI to RS232 serial converter DriveExplorer Lite Version 3.01 or later 1203-SFC and 22-RJ45CBL-C20 Cables	22-SCM-232
Serial Cable	2.0 meter serial cable with a locking low profile connector to connect to the serial converter and a 9-pin sub-miniature D female connector to connect to a computer.	1203-SFC
Null Cable Converter	For use when connecting the serial converter to DriveExplorer on a handheld PC.	1203-SNM
Universal Serial Bus™ (USB) Converter	Provides a direct, isolated USB connection for use with DriveExplorer and DriveExecutive software. Includes 2.0 meter USB cable, 20-HIM-H10 and 22-HIM-H10 cables.	1203-USB
DSI Cable	2.0 meter RJ45 to RJ45 cable, male to male connectors.	22-RJ45CBL-C20
Splitter Cable	RJ45 one to two port splitter cable.	AK-U0-RJ45-SC1
Terminating Resistors	RJ45 120 Ohm resistor (2 pieces).	AK-U0-RJ45-TR1
Terminal Block	RJ45 Two position terminal block (6 pieces).	AK-U0-RJ45-TB2P
External DSI Communications Kit	External communications kit for 22-COMM Communication Adapters. Multi-Drive capability allows connectivity for up to 5 drives.	22-XCOMM-DC-BASE
External Comms Power Supply	Optional 100-240V AC power supply for external DSI communications kit.	20-XCOMM-AC-PS1
Communication Adapters	Embedded communication option for use with the PowerFlex family of drives. Requires a Communication Adapter Cover (Ordered Separately). BACnet ControlNet DeviceNet EtherNet/IP LonWorks PROFIBUS DP	22-COMM-B 22-COMM-C 22-COMM-D 22-COMM-E 22-COMM-L 22-COMM-P
Compact I/O Module	Provides 3 channels that can be individually configured for Single, Multi-Drive, and Modbus RTU modes.	1769-SM2
Communication Adapter Covers	Houses the optional communication adapters. These covers add 25 mm (0.98 in.) to the overall depth of the drive. PowerFlex 40 Drive Frame B PowerFlex 40 Drive Frame C	22B-CCB 22B-CCC

❶ For pricing information, refer to the PowerFlex 4 Price List, publication 22A-PL001 and PowerFlex 40 Price List, publication 22B-PL001.

Shaded areas are applicable to PowerFlex 40 only.

PC Programming Software

Item	Description	Catalog Number
DriveTools SP Software	"Windows" based software package that provides an intuitive means for monitoring or configuring Allen-Bradley drives and communications adapters online and offline. Compatibility: Windows 98, ME, NT, 4.0 (Service Pack 3 or later), 2000 and XP. ❶	9303-4DTE01ENE
DriveExplorer™ Software	"Windows" based software package that provides an intuitive means for monitoring or configuring Allen-Bradley drives and communications adapters online and offline. Compatibility: Windows 98, ME, NT, 4.0 (Service Pack 3 or later), 2000 and XP. ❶	9306-4EXP01ENE

❶ See www.ab.com/drive/ for support devices.

DC Bus Inductors

Input Voltage	kW	HP	Amps	Inductance mh	MTE Catalog Number
240V 50/60 Hz 3-Phase	5.5	7.5	32	0.85	32RB001
	7.5	10.0	40	0.5	40RB001
480V 50/60 Hz 3-Phase	5.5	7.5	18	3.75	18RB004
	7.5	10.0	25	4.0	25RB005
	11.0	15.0	32	2.68	32RB003
600V 50/60 Hz 3-Phase	5.5	7.5	12	6.0	12RB004
	7.5	10.0	18	6.0	18RB005
	11.0	15.0	25	4.0	25RB005

Dynamic Brake Resistors

Drive Ratings			PowerFlex 4	PowerFlex 40
Input Voltage	kW	HP	Catalog Number ❶	Catalog Number ❶
120V 50/60 Hz 1-Phase	0.2	0.25	AK-R2-091P500	–
	0.4	0.5	AK-R2-091P500	–
	0.75	1.0	AK-R2-091P500	–
	1.1	1.5	AK-R2-091P500	–
240V 50/60 Hz 1-Phase	0.2	0.25	AK-R2-091P500	–
	0.4	0.5	AK-R2-091P500	–
	0.75	1.0	AK-R2-091P500	–
	1.5	2.0	AK-R2-091P500	–
	2.2	3.0	–	AK-R2-047P500
240V 50/60 Hz 3-Phase	0.2	0.25	AK-R2-091P500	–
	0.4	0.5	AK-R2-091P500	–
	0.75	1.0	AK-R2-091P500	–
	1.5	2.0	AK-R2-091P500	–
	2.2	3.0	AK-R2-047P500	–
	3.7	5.0	AK-R2-047P500	–
	5.5	7.5	–	AK-R2-030P1K2
	7.5	10.0	–	AK-R2-030P1K2
480V 50/60 Hz 3-Phase	0.4	0.5	AK-R2-360P500	–
	0.75	1.0	AK-R2-360P500	–
	1.5	2.0	AK-R2-360P500	–
	2.2	3.0	AK-R2-120P1K2	–
	4.0	5.0	AK-R2-120P1K2	–
	5.5	7.5	–	AK-R2-120P1K2
	7.5	10.0	–	AK-R2-120P1K2
600V 50/60 Hz 3-Phase No Filter	0.75	1.0	–	AK-R2-360P500
	1.5	2.0	–	AK-R2-360P500
	2.2	3.0	–	AK-R2-120P1K2
	4.0	5.0	–	AK-R2-120P1K2
	5.5	7.5	–	AK-R2-120P1K2
	7.5	10.0	–	AK-R2-120P1K2
600V 50/60 Hz 3-Phase No Filter	11.0	15.0	–	AK-R2-120P1K2
	0.75	1.0	–	AK-R2-360P500
	1.5	2.0	–	AK-R2-360P500
	2.2	3.0	–	AK-R2-120P1K2

❶ Resistors listed in this table are rated for a minimum 5% duty cycle. See publication no. PFLEX-AT001x-EN-P for additional information.

❷ Requires two resistors wired in parallel.

3% Line Reactors

Input Voltage	kW	HP	Fundamental Amps	Max Continuous Amps	Inductance mh	Watts Loss	Catalog Number ❶	
240V 50/60 Hz 3-Phase	0.2	0.25	2	3	12.0	7.5 W	1321-3R2-A	
	0.4	0.5	4	6	12.0	21 W	1321-3R4-D	
	0.75	1.0	8	12	3.0	29 W	1321-3R8-B	
	1.5	2.0	8	12	1.5	19.5 W	1321-3R8-A	
	2.2	3.0	12	18	1.25	26 W	1321-3R12-A	
	3.7	5.0	18	27	0.8	36 W	1321-3R18-A	
	5.5	7.5	25	37.5	0.5	48 W	1321-3R25-A	
	7.5	10.0	35	52.5	0.4	49 W	1321-3R35-A	
	480V 50/60 Hz 3-Phase	0.4	0.5	2	3	20.0	11.3 W	1321-3R2-B
	0.75	1.0	4	6	9.0	20 W	1321-3R4-C	
1.5	2.0	4	6	6.5	20 W	1321-3R4-B		
2.2	3.0	8	12	5.0	25.3 W	1321-3R8-C		
3.7	5.0	8	12	3.0	29 W	1321-3R8-B		
4.0	5.0	12	18	2.5	31 W	1321-3R12-B		
5.5	7.5	12	18	2.5	31 W	1321-3R12-B		
7.5	10.0	18	27	1.5	43 W	1321-3R18-B		
11.0	15.0	25	37.5	1.2	52 W	1321-3R25-B		
600V 50/60 Hz 3-Phase No Filter	0.75	1.0	2	3	20.0	11.3 W	1321-3R2-B	
	1.5	2.0	4	6	6.5	20 W	1321-3R4-B	
	2.2	3.0	4	6	6.5	20 W	1321-3R4-B	
	4.0	5.0	8	12	5.0	25.3 W	1321-3R8-C	
	5.5	7.5	12	18	2.5	31 W	1321-3R12-B	
	7.5	10.0	12	18	2.5	31 W	1321-3R12-B	
	11.0	15.0	18	27	1.5	43 W	1321-3R18-B	

❶ Catalog numbers listed are for 3% impedance open style units. NEMA Type 1 and 5% impedance reactor types are also available. Refer to publication 1321-TD001x-EN-P.

Shaded areas are applicable to PowerFlex 40 only.

PowerFlex 4 EMC Filters

Drive Ratings			S Type Filter	L Type Filter
Input Voltage	kW	HP	Catalog Number ❶	Catalog Number ❷
120V 50/60 Hz 1-Phase	0.2	0.25	–	22-RF010-AL
	0.4	0.5	–	22-RF010-AL
	0.75	1.0	–	22-RF018-BL
240V 50/60 Hz 1-Phase	0.2	0.25	❸	22-RF010-AL
	0.4	0.5	❸	22-RF010-AL
	0.75	1.0	❸	22-RF010-AL
	1.5	2.0	❸	22-RF018-BL
240V 50/60 Hz 3-Phase	0.2	0.25	22-RF9P5-AS	22-RF9P5-AL
	0.4	0.5	22-RF9P5-AS	22-RF9P5-AL
	0.75	1.0	22-RF9P5-AS	22-RF9P5-AL
	1.5	2.0	22-RF9P5-AS	22-RF9P5-AL
	2.2	3.0	22-RF021-BS	22-RF021-BL
	3.7	5.0	22-RF021-BS	22-RF021-BL
480V 50/60 Hz 3-Phase	0.4	0.5	22-RF5P7-AS	22-RF5P7-AL
	0.75	1.0	22-RF5P7-AS	22-RF5P7-AL
	1.5	2.0	22-RF5P7-AS	22-RF5P7-AL
	2.2	3.0	22-RF012-BS	22-RF012-BL
	4.0	5.0	22-RF012-BS	22-RF012-BL

PowerFlex 40 EMC Filters

Drive Ratings			S Type Filter	L Type Filter	
Input Voltage	kW	HP	Catalog Number ❶	Catalog Number ❷	
120V 50/60 Hz 1-Phase	0.4	0.5	–	22-RF018-BL	
	0.75	1.0	–	22-RF018-BL	
	1.1	1.5	–	22-RF018-BL	
240V 50/60 Hz 1-Phase	0.4	0.5	❸	22-RF018-BL	
	0.75	1.0	❸	22-RF018-BL	
	1.5	2.0	❸	22-RF018-BL	
	2.2	3.0	❸	22-RF025-CL	
	3.7	5.0	–	–	
240V 50/60 Hz 3-Phase	0.4	0.5	22-RF021-BS ❹	22-RF021-BL	
	0.75	1.0	22-RF021-BS ❹	22-RF021-BL	
	1.5	2.0	22-RF021-BS ❹	22-RF021-BL	
	2.2	3.0	22-RF021-BS ❹	22-RF021-BL	
	3.7	5.0	22-RF021-BS ❹	22-RF021-BL	
	5.5	7.5	22-RF034-CS	22-RF034-CL	
	7.5	10.0	22-RF034-CS	22-RF034-CL	
	480V 50/60 Hz 3-Phase	0.4	0.5	22-RF012-BS	22-RF012-BL
	0.75	1.0	22-RF012-BS	22-RF012-BL	
	1.5	2.0	22-RF012-BS	22-RF012-BL	
2.2	3.0	22-RF012-BS	22-RF012-BL		
4.0	5.0	22-RF012-BS	22-RF012-BL		
5.5	7.5	22-RF018-CS	22-RF018-CL		
7.5	10.0	22-RF018-CS	22-RF018-CL		
11.0	15.0	22-RF026-CS	22-RF026-CL		
600V 50/60 Hz 3-Phase	0.75	1.0	–	22-RF8P0-BL	
	1.5	2.0	–	22-RF8P0-BL	
	2.2	3.0	–	22-RF8P0-BL	
	4.0	5.0	–	22-RF8P0-BL	
	5.5	7.5	–	22-RF015-CL	
	7.5	10.0	–	22-RF015-CL	
	11.0	15.0	–	22-RF024-CL	

- ❶ This filter is suitable for use with a cable length up to 10 meters for Class A and 1 meter for Class B environments.
- ❷ This filter is suitable for use with a cable length up to 100 meters for Class A and 5 meters for Class B environments.
- ❸ Drives are available in these ratings with internal "S Type" filters.
- ❹ Filter must be Series B or later.

PowerFlex 4 & 40 Spare Parts

Description	Catalog Number
PowerFlex 4 Fan Replacement Kit - Frame A	SK-U1-FAN1-A1
PowerFlex 4/40 Fan Replacement Kit - Frame B, 1 Fan	SK-U1-FAN1-B1
PowerFlex 4/40 Fan Replacement Kit - Frame B, 2 Fans	SK-U1-FAN2-B1
PowerFlex 40 Fan Replacement Kit - Frame C, 1 Fan	SK-U1-FAN1-C1
PowerFlex 40 Fan Replacement Kit - Frame C, 1 Fan (15 HP)	SK-U1-FAN1-C2
PowerFlex 4 Frame A Cover with Power Terminal Guard	SK-U1-ACVR1-A1
PowerFlex 4 Frame B Cover with Power Terminal Guard	SK-U1-ACVR1-B1
PowerFlex 40 Frame B Cover with Power Terminal Guard	SK-U1-BCVR1-B1
PowerFlex 40 Frame C Cover with Power Terminal Guard	SK-U1-BCVR1-C1

Shaded areas are applicable to PowerFlex 40 only.

Installation Considerations

PowerFlex 4 and 40 drives have the following built in protective features to help simplify installation.

- Ground fault protection while starting and running ensures reliable operation
- Electronic motor overload protection increases motor life
- Removable MOV to ground ensures compatibility with ungrounded systems
- 6kV transient protection provides increased robustness for 380-480V system voltages

There are many other factors that must be considered for optimal performance in any given application. The block diagram below highlights the primary installation considerations. Consult the PowerFlex 4 or PowerFlex 40 User Manual, Publications 22A-UM001... or 22B-UM001... available online at www.ab.com/manuals/dr, for detailed recommendations on input power conditioning, CE conformance (EMC filtering), dynamic braking, reflected wave protection, motor cable types and motor cable distances.

Block Diagram

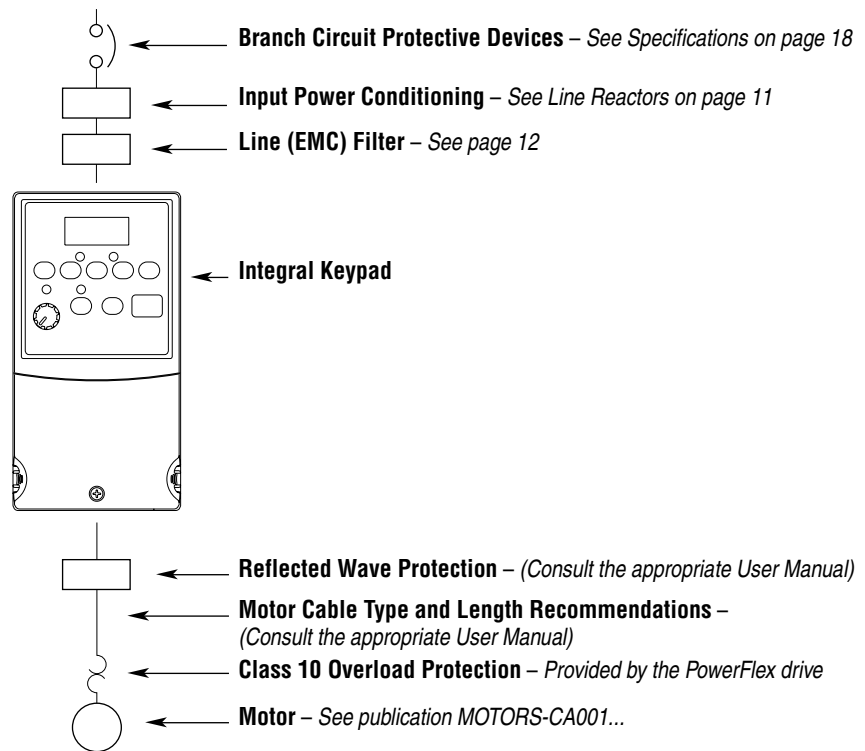

Control Wiring

PowerFlex 4

- The control logic is 24V DC and can be set for either Sink or Source control via a DIP switch setting.
- Control terminal screws are sized for a conventional blade screw driver.
- I/O Terminals 1, 2 and 3 are dedicated for Stop, Start and Reverse operation respectively. These I/O Terminals can be programmed for 2- or 3-Wire operation to meet application requirements.
- I/O Terminals 4 and 5 are programmable and provide added flexibility. Programmable functions include:
 - Local Control
 - Preset Frequencies
 - Jog
 - RS485 Control
 - Second Accel/Decel
 - Auxiliary Fault
 - Clear Fault
- Speed can be controlled via a 0-10V input or 4-20 mA input. Both are electrically isolated from the drive.
- One form C relay can be programmed to provide the status of a wide variety of drive conditions.
- The drive is shipped with a jumper installed between I/O Terminals 01 and 11 to allow out of box operation from the keypad.

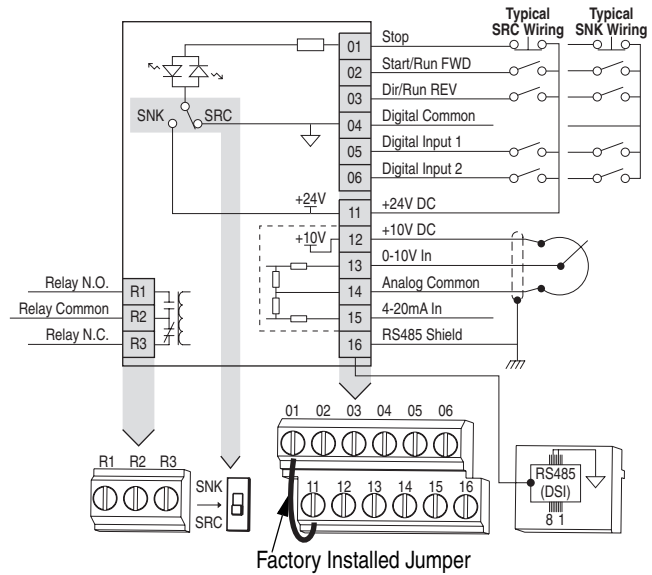

PowerFlex 40

- The control logic is 24V DC and can be set for either Sink or Source control via a DIP switch setting.
- Control terminal screws are sized for a conventional blade screw driver.
- I/O Terminals 1, 2 and 3 are dedicated for Stop, Start and Reverse operation respectively. These I/O Terminals can be programmed for 2- or 3-Wire operation to meet application requirements.
- I/O Terminals 5, 6, 7 and 8 are programmable and provide added flexibility. Programmable functions include Local Control, Jog, Second Accel/Decel, Clear Fault, Preset Frequencies, RS485 Control and Auxiliary Fault.
- Speed can be controlled via a 0-10V input and/or 4-20 mA input. Both inputs are independently isolated from the rest of the drive and can be used for applications such as PID. Voltage input can be programmed for bipolar operation.
- The drive is shipped with a jumper installed between I/O Terminals 01 and 11 to allow out of box operation from the keypad.

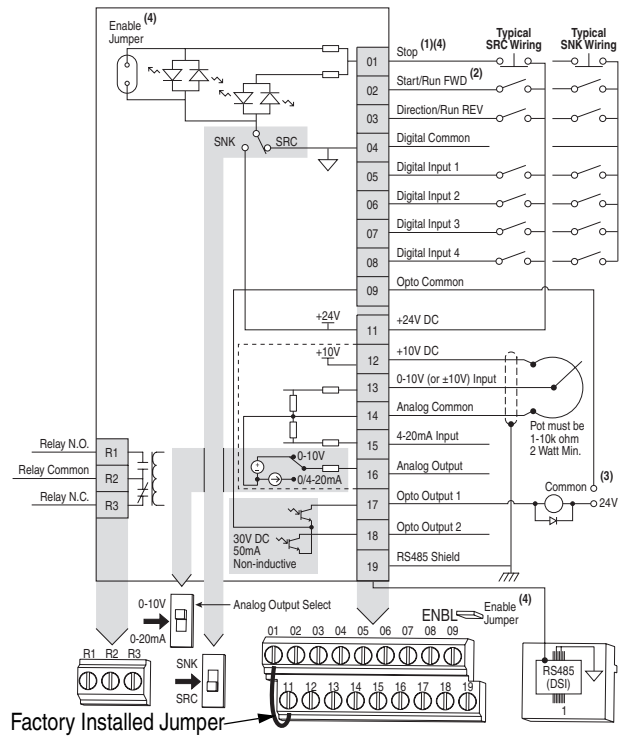

No.	Signal	Default	Description
R1	Relay N.O.	Fault	Normally open contact for output relay.
R2	Relay Common	–	Common for output relay.
R3	Relay N.C.	Fault	Normally closed contact for output relay.
Analog Output Select DIP Switch		0-10V	Sets analog output to either voltage or current. Setting must match A065 [Analog Out Sel].
Sink/Source DIP Switch		Source (SRC)	Inputs can be wired as Sink (SNK) or Source (SRC) via DIP Switch setting.
01	Stop	Coast	The factory installed jumper or a normally closed input must be present for the drive to start.
02	Start/Run FWD	Not Active	Command comes from the integral keypad by default. To disable reverse operation, see A095 [Reverse Disable].
03	Direction/Run REV	Not Active	
04	Digital Common	–	For digital inputs. Electronically isolated with digital inputs from analog I/O and opto outputs.
05	Digital Input 1	Preset Freq	Program with A051 [Digital In1 Sel].
06	Digital Input 2	Preset Freq	Program with A052 [Digital In2 Sel].
07	Digital Input 3	Local	Program with A053 [Digital In3 Sel].
08	Digital Input 4	Jog Forward	Program with A054 [Digital In4 Sel].
09	Opto Common	–	For opto-coupled outputs. Electronically isolated with opto outputs from analog I/O and digital inputs.
11	+24V DC	–	Referenced to Digital Common. Drive supplied power for digital inputs. Maximum output current is 100mA.
12	+10V DC	–	Referenced to Analog Common. Drive supplied power for 0-10V external potentiometer. Maximum output current is 15mA.
13	±10V In ⁽¹⁾	Not Active	For external 0-10V (unipolar) or ±10V (bipolar) input supply (input impedance = 100k ohm) or potentiometer wiper.
14	Analog Common	–	For 0-10V In or 4-20mA In. Electronically isolated with analog inputs and outputs from digital I/O and opto outputs.
15	4-20mA In ⁽¹⁾	Not Active	For external 4-20mA input supply (input impedance = 250 ohm).
16	Analog Output	OutFreq 0-10	The default analog output is 0-10V. To covert to a current value, change the Analog Output Select DIP Switch to 0-20mA. Program with A065 [Analog Out Sel]. Max analog value can be scaled with A066 [Analog Out High]. Maximum Load:4-20mA = 525 ohm (10.5V) 0-10V = 1k ohm (10mA)
17	Opto Output 1	MotorRunning	Program with A058 [Opto Out1 Sel]
18	Opto Output 2	At Frequency	Program with A061 [Opto Out2 Sel]
19	RS485 (DSI) Shield	–	Terminal should be connected to safety ground - PE when using the RS485 (DSI) communications port.

(1) 0-10V In and 4-20mA In are distinct input channels and may be connected simultaneously Inputs may be used independently for speed control or jointly when operating in PID mode.

Specifications

Drive Ratings — PowerFlex 4										
Catalog Number	Output Ratings		Input Ratings			Branch Circuit Protection			Power Dissipation	
	kW (HP)	Amps	Voltage Range	kVA	Amps	Fuses ❶	140M Motor Protectors ❷	Contactors	Internal	Total
100 - 120V AC – 1-Phase Input, 0 - 230V 3-Phase Output										
22A-V1P5N104	0.2 (0.25)	1.5	90-126	0.75	6.0	10	140M-C2E-C10	100-C09	10	25
22A-V2P3N104	0.4 (0.5)	2.3	90-126	1.15	9.0	15	140M-C2E-C16	100-C12	9	30
22A-V4P5N104	0.75 (1.0)	4.5	90-126	2.25	18.0	30	140M-D8E-C20	100-C23	12	50
22A-V6P0N104	1.1 (1.5)	6.0	90-126	3.00	24.0	40	140M-D8E-C32	100-C37	12	70
200 - 240V AC – 1-Phase Input, 0 - 230V 3-Phase Output (No Brake) ❸										
22A-A1P4N103	0.2 (0.25)	1.4	180-265	0.7	3.2	6	140M-C2E-B40	100-C09	10	25
22A-A2P1N103	0.4 (0.5)	2.1	180-265	1.05	5.3	10	140M-C2E-B63	100-C09	9	30
22A-A3P6N103	0.75 (1.0)	3.6	180-265	1.8	9.2	15	140M-C2E-C16	100-C12	12	50
22A-A6P8N103	1.5 (2.0)	6.8	180-265	3.4	14.2	25	140M-C2E-C16	100-C16	16	80
22A-A9P6N103	2.2 (3.0)	9.6	180-265	4.8	19.6	30	140M-D8E-C25	100-C23	11	110
200 - 240V AC – 1-Phase Input, 0 - 230V 3-Phase Output ❸										
22A-A1P5N104	0.2 (0.25)	1.5	180-265	0.75	5.0	10	140M-C2E-B63	100-C09	10	25
22A-A2P3N104	0.4 (0.5)	2.3	180-265	1.15	6.0	10	140M-C2E-B63	100-C09	9	30
22A-A4P5N104	0.75 (1.0)	4.5	180-265	2.25	10.0	15	140M-C2E-C16	100-C12	12	50
22A-A8P0N104	1.5 (2.0)	8.0	180-265	4.0	18.0	30	140M-D8E-C20	100-C23	16	80
200 - 240V AC – 3-Phase Input, 0 - 230V 3-Phase Output										
22A-B1P5N104	0.2 (0.25)	1.5	180-265	0.75	1.8	3	140M-C2E-B25	100-C09	10	25
22A-B2P3N104	0.4 (0.5)	2.3	180-265	1.15	2.5	6	140M-C2E-B40	100-C09	9	30
22A-B4P5N104	0.75 (1.0)	4.5	180-265	2.25	5.2	10	140M-C2E-C10	100-C09	12	50
22A-B8P0N104	1.5 (2.0)	8.0	180-265	4.0	9.5	15	140M-C2E-C16	100-C12	16	80
22A-B012N104	2.2 (3.0)	12.0	180-265	5.5	15.5	25	140M-C2E-C16	100-C16	16	115
22A-B017N104	3.7 (5.0)	17.5	180-265	8.6	21.0	35	140M-F8E-C25	100-C23	16	165
380 - 480V AC – 3-Phase Input, 0 - 460V 3-Phase Output										
22A-D1P4N104	0.4 (0.5)	1.4	340-528	1.4	1.8	3	140M-C2E-B25	100-C09	15	30
22A-D2P3N104	0.75 (1.0)	2.3	340-528	2.3	3.2	6	140M-C2E-B40	100-C09	13	40
22A-D4P0N104	1.5 (2.0)	4.0	340-528	4.0	5.7	10	140M-C2E-B63	100-C09	13	60
22A-D6P0N104	2.2 (3.0)	6.0	340-528	5.9	7.5	15	140M-C2E-C10	100-C09	17	90
22A-D8P7N104	3.7 (5.0)	8.7	340-528	8.6	9.0	15	140M-C2E-C16	100-C16	14	145

- ❶ Recommended Fuse Type: UL Class J, CC, T or Type BS88; 600V (550V) or equivalent.
- ❷ Refer to Bulletin 140M Motor Protectors Selection Guide, publication 140-SG001... to determine the frame and breaking capacity required for your application.
- ❸ 200-240V AC - 1-Phase drives are also available with an integral EMC filter. Catalog suffix changes from N104 to N114 or N103 to N113.

Drive Ratings — PowerFlex 40										
Catalog Number	Output Ratings		Input Ratings			Branch Circuit Protection			Power Dissipation	
	kW (HP)	Amps	Voltage Range	kVA	Amps	Fuses ❶	140M Motor Protectors ❷	Contactors	Internal	Total
100 - 120V AC – 1-Phase Input, 0 - 230V 3-Phase Output										
22B-V2P3N104	0.4 (0.5)	2.3	90-132	1.15	9.0	15	140M-C2E-C16	100-C12	9	30
22B-V5P0N104	0.75 (1.0)	5.0	90-132	2.45	20.3	35	140M-D8E-C20	100-C23	12	55
22B-V6P0N104	1.1 (1.5)	6.0	90-132	3.0	24.0	40	140M-F8E-C32	100-C37	12	70
200 - 240V AC – 1-Phase Input, 0 - 230V 3-Phase Output ❸										
22B-A2P3N104	0.4 (0.5)	2.3	180-264	1.15	6.0	10	140M-C2E-B63	100-C09	9	30
22B-A5P0N104	0.75 (1.0)	5.0	180-264	2.45	12.0	20	140M-C2E-C16	100-C12	12	55
22B-A8P0N104	1.5 (2.0)	8.0	180-264	4.0	18.0	30	140M-D8E-C20	100-C23	16	80
22B-A012N104	2.2 (3.0)	12.0	180-264	5.5	25.0	40	140M-F8E-C32	100-C37	11	110
200 - 240V AC – 3-Phase Input, 0 - 230V 3-Phase Output										
22B-B2P3N104	0.4 (0.5)	2.3	180-264	1.15	2.5	6	140M-C2E-B40	100-C07	9	30
22B-B5P0N104	0.75 (1.0)	5.0	180-264	2.45	5.7	10	140M-C2E-C10	100-C09	12	55
22B-B8P0N104	1.5 (2.0)	8.0	180-264	4.0	9.5	15	140M-C2E-C16	100-C12	16	80
22B-B012N104	2.2 (3.0)	12.0	180-264	5.5	15.5	25	140M-C2E-C16	100-C23	16	115
22B-B017N104	3.7 (5.0)	17.5	180-264	8.6	21.0	35	140M-F8E-C25	100-C23	16	165
22B-B024N104	5.5 (7.5)	24.0	180-264	11.8	26.1	40	140M-F8E-C32	100-C37	28	225
22B-B033N104	7.5 (10.0)	33.0	180-264	16.3	34.6	60	140M-F8E-C45	100-C60	28	290
380 - 480V AC – 3-Phase Input, 0 - 460V 3-Phase Output										
22B-D1P4N104	0.4 (0.5)	1.4	342-528	1.4	1.8	3	140M-C2E-B25	100-C07	15	30
22B-D2P3N104	0.75 (1.0)	2.3	342-528	2.3	3.2	6	140M-C2E-B40	100-C07	13	40
22B-D4P0N104	1.5 (2.0)	4.0	342-528	4.0	5.7	10	140M-C2E-B63	100-C09	13	60
22B-D6P0N104	2.2 (3.0)	6.0	342-528	5.9	7.5	15	140M-C2E-C10	100-C09	17	90
22B-D010N104	4.0 (5.0)	10.5	342-528	10.3	13.0	20	140M-C2E-C16	100-C23	14	150
22B-D012N104	5.5 (7.5)	12.0	342-528	11.8	14.2	25	140M-D8E-C20	100-C23	23	160
22B-D017N104	7.5 (10.0)	17.0	342-528	16.8	18.4	30	140M-D8E-C20	100-C23	24	200
22B-D024N104	11.0 (15.0)	24.0	342-528	23.4	26.0	50	140M-F8E-C32	100-C43	25	285
460 - 600V AC – 3-Phase Input, 0 - 575V 3-Phase Output										
22B-E1P7N104	0.75 (1.0)	1.7	414-660	2.1	2.3	6	140M-C2E-B25	100-C09	13	40
22B-E3P0N104	1.5 (2.0)	3.0	414-660	3.65	3.8	6	140M-C2E-B40	100-C09	13	60
22B-E4P2N104	2.2 (3.0)	4.2	414-660	5.2	5.3	10	140M-C2E-B63	100-C09	17	90
22B-E6P6N104	4.0 (5.0)	6.6	414-660	8.1	8.3	15	140M-C2E-C10	100-C09	14	150
22B-E9P9N104	5.5 (7.5)	9.9	414-660	12.1	11.2	20	140M-C2E-C16	100-C16	23	160
22B-E012N104	7.5 (10.0)	12.2	414-660	14.9	13.7	25	140M-C2E-C16	100-C23	24	200
22B-E019N104	11.0 (15.0)	19.0	414-660	23.1	24.1	40	140M-D8E-C25	100-C30	25	285

❶ Recommended Fuse Type: UL Class J, CC, T or Type BS88; 600V (550V) or equivalent.

❷ Refer to Bulletin 140M Motor Protectors Selection Guide, publication 140-SG001... to determine the frame and breaking capacity required for your application.

❸ 200-240V AC - 1-Phase drives are also available with an integral EMC filter. Catalog suffix changes from N104 to N114 or N103 to N113.

Input/Output Ratings	Output Frequency: Efficiency:	PowerFlex 4: 0-240 Hz (Programmable) PowerFlex 40: 0-400 Hz (Programmable) 97.5% (Typical)
Approvals		
Control Inputs	Digital SRC (Source) Mode: SNK (Sink) Mode: Analog 4-20 mA Analog: 0-10V DC Analog: External Pot:	Input Current = 6 mA 18-24V = On, 0-6V = Off 0-6V = On, 18-24V = Off 250 ohm input impedance 100k ohm input impedance 1-10k ohms, 2 Watt minimum
Control Output – Programmable Output (form C relay)	Resistive Rating Opto Outputs (PF 40): Analog Outputs (PF 40): Inductive Rating Opto Outputs (PF 40): Analog Outputs (PF 40):	3.0A at 30V DC, 3.0A at 125V AC, 3.0A at 240V AC 30V DC, 50 mA 10-bit, 0-10V, 1k ohm minimum 0.5A at 30V DC, 0.5A at 125V AC, 0.5A at 240V AC Non-inductive 10 bit, 4-20 mA, 525 ohm maximum
Fuses and Circuit Breakers	Recommended Fuse Type: Recommended Circuit Breakers:	UL Class J, CC, T or Type BS88; 600V (550V) or equivalent. HMCP circuit breaker or equivalent.
Protective Features	Motor Protection: Overcurrent: Control Ride Through: Faultless Power Ride Through: Over Voltage: Under Voltage:	I ² t Overload Protection, 150% for 60 sec., 200% for 3 sec. (provides Class 10 protection) 200% hardware limit, 300% instantaneous fault Minimum Ride Through is 0.5 sec. - typical value is 2 seconds 100 milliseconds 100-120V AC Input – Trip occurs at 405V DC bus voltage (= 150V AC incoming line) 200-240V AC Input – Trip occurs at 405V DC bus voltage (= 290V AC incoming line) 380-480V AC Input – Trip occurs at 810V DC bus voltage (= 575V AC incoming line) 460-600V AC Input (PF 40) – Trip occurs at 1005V DC bus voltage (= 711V AC incoming line) 100-120V AC Input – Trip occurs at 210V DC bus voltage (= 75V AC incoming line) 200-240V AC Input – Trip occurs at 210V DC bus voltage (= 150V AC incoming line) 380-480V AC Input – Trip occurs at 390V DC bus voltage (= 275V AC incoming line) 460-600V AC Input (PF 40) If P042 = 1 “High Voltage” trip occurs at 487V DC bus voltage (344V AC incoming line); If P042 = 0 “Low Voltage” trip occurs at 390V DC bus voltage (275V AC incoming line)
Dynamic Braking	Internal brake IGBT included with all ratings except No Brake drives (Cat. Nos. 22A-AxPxN103 or 22A-AxPxN113). Refer to page 11 for ordering information.	
Environment	Altitude: Ambient Operating Temperature: Cooling Method: Storage Temperature: Atmosphere: Relative Humidity: Shock (operating): Vibration (operating):	1000 m (3300 ft.) maximum without derating IP20, NEMA/UL Type Open: -10 to 50 degrees C (14 to 122 degrees F) IP30, NEMA/UL Type 1: -10 to 40 degrees C (14 to 104 degrees F) IP66, NEMA/UL Type 4X/12 (PF 40): -10 to 40 degrees C (14 to 104 degrees F) Fan, all drive ratings -40 to 85 degrees C (-40 to 185 degrees F) Important: Drive <u>must not</u> be installed in an area where the ambient atmosphere contains volatile or corrosive gas, vapors or dust. If the drive is not going to be installed for a period of time, it must be stored in an area where it will not be exposed to a corrosive atmosphere. 0 to 95% non-condensing 15G peak for 11ms duration (±1.0ms) 1G peak, 5 to 2000 Hz
Control	Carrier Frequency: Frequency Accuracy: Speed Regulation: Stop Modes: Accel/Decel: Intermittent Overload: Electronic Motor Overload Protection:	2-16 kHz. Drive rating based on 4 kHz. Digital Input: Within ±0.05% of set output frequency. Analog Input: Within 0.5% of maximum output frequency. Analog Output (PF 40): ±2% of full scale, 10-bit resolution. Open Loop with Slip Compensation: ±2% of base speed across a 40:1 speed range. (PF 40): 1% of base speed across a 60:1 speed range. Multiple programmable stop modes including - Ramp, Coast, DC-Brake, Ramp-to-Hold and S Curve. Two independently programmable accel and decel times. Each time may be programmed from 0-600 seconds in 0.1 second increments. 150% overload capability for up to 1 minute, 200% overload capability for up to 3 seconds. Class 10 protection with speed sensitive response.
Electrical	Voltage Tolerance: Frequency Tolerance: Displacement Power Factor: Maximum Short Circuit Rating:	120V, 200-240V, 380-480V, 460-600V: ±10% 48-63 Hz 0.98 across entire speed range 100,000 Amps symmetrical

Parameter Descriptions

Parameter Number	Parameter Name	Description	Factory Default
<i>Display Group</i>			
d001	Output Freq	Output frequency present at T1, T2 & T3 (U, V & W)	Read Only
d002	Commanded Freq	Value of the active frequency command	Read Only
d003	Output Current	Output current present at T1, T2 & T3 (U, V & W)	Read Only
d004	Output Voltage	Output voltage present at T1, T2 & T3 (U, V & W)	Read Only
d005	DC Bus Voltage	Present DC bus voltage level	Read Only
d006	Drive Status	Present operating condition of the drive	Read Only
d007-d009	Fault x Code	A code that represents a drive fault	Read Only
d010	Process Display	The output frequency scaled by parameter A099 [Process Factor]	Read Only
d012	Control Source	Displays the source of the Start Command and Speed Reference	Read Only
d013	Contrl In Status	Status of the control terminal block control inputs	Read Only
d014	Dig In Status	Status of the control terminal block digital inputs	Read Only
d015	Comm Status	Status of the communications ports	Read Only
d016	Control SW Ver	Main Control Board software version	Read Only
d017	Drive Type	Used by Rockwell Automation field service personnel	Read Only
d018	Elapsed Run Time	Accumulated time drive is outputting power	Read Only
d019	Testpoint Data	The present value of the function selected in parameter A102 [Testpoint Sel]	Read Only
d020	Analog In 0-10V	The present value of the voltage at I/O Terminal 13 (100.0% = 10 volts)	Read Only
d021	Analog In 4-20mA	The present value of the current at I/O Terminal 15 (0.0% = 4 mA, 100.0% = 20 mA)	Read Only
d022	Output Power	Output power present at T1, T2 & T3 (U, V & W)	Read Only
d023	Output Power Fctr	The angle in electrical degrees between motor voltage and motor current	Read Only
d024	Drive Temp	Present operating temperature of the drive power section	Read Only
d025	Counter Status	The current value of the counter when counter is enabled	Read Only
d026	Timer Status	The current value of the timer when timer is enabled	Read Only
d028	Stp Logic Status	When P038 [Speed Reference] is set to 6 "Stp Logic", this parameter will display the current step logic profile as defined by parameters A140-A147 [Stp Logic x]	Read Only
d029	Torque Current	Displays the current value of the motor torque current as measured by the drive	Read Only
<i>Basic Program Group</i>			
P031	Motor NP Volts	20 to drive rated volts	Based on Drive Rating
P032	Motor NP Hertz	10 to 240 Hz	60 Hz
		15 to 400 Hz	60 Hz
P033	Motor OL Current	0.0 Amps to (Drive Rated Amps x 2) in units of 0.1 Amps	Based on Drive Rating
P034	Minimum Freq	0.0 to 240.0 Hz	0.0 Hz
		0.0 to 400.0 Hz	0.0 Hz
P035	Maximum Freq	0 to 240 Hz	60 Hz
		0 to 400 Hz	60 Hz
P036	Start Source	6 settings; Keypad, 3-Wire, 2-Wire, 2-Wire Level Sensitive, 2-Wire High Speed, Comm Port	Keypad
		7 settings; Keypad, 3-Wire, 2-Wire, 2-Wire Level Sensitive, 2-Wire High Speed, Comm Port, Momentary FWD/REV	Keypad
P037	Stop Mode	8 settings; Ramp-Clear Fault, Coast-Clear Fault, DC Brake-Clear Fault, DC Brake w/Shutoff-Clear Fault, Ramp, Coast, DC Brake, DC Brake w/Shutoff	Ramp, CF (Clear Fault)
		10 settings; Ramp-Clear Fault, Coast-Clear Fault, DC Brake-Clear Fault, DC Brake w/Shutoff-Clear Fault, Ramp, Coast, DC Brake, DC Brake w/Shutoff, Ramp Stop w/EM Brake Control-Clear Fault, Ramp Stop w/EM Brake Control	Ramp, CF (Clear Fault)
P038	Speed Reference	6 settings; Drive Potentiometer, Internal Freq, 0-10V Input/Remote Potentiometer, 4-20 mA Input, Preset Freq 0-3, Communications Port	Drive Pot
		8 settings; Drive Potentiometer, Internal Freq, 0-10V Input/Remote Potentiometer, 4-20 mA Input, Preset Freq 0-7, Communications Port, Step Logic, Analog In Mult	Drive Pot
P039	Accel Time 1	0.0 to 600.0 seconds	10.0 Secs
P040	Decel Time 1	0.1 to 600.0 seconds	10.0 Secs
P041	Reset To Defaults	Used to reset drive to factory default settings	Ready/Idle
P042	Voltage Class	Sets the voltage class of 600V drives, Low Voltage (460/480V) or High Voltage (575/600V)	High Voltage (575/600V)
P043	Motor OL Ret	Enables/Disables the Motor Overload Retention function.	Disabled
<i>Advanced Program Group</i>			
A051 A052	Digital In1 Sel Digital In2 Sel	16 settings; Not Used, Accel 2 & Decel 2, Jog, Auxiliary Fault, Preset Frequencies, Local, Comm Port, Clear Fault, Ramp Stop Clear Fault, Coast Stop Clear Fault, DC Brake Clear Fault, Jog Forward, Jog Reverse, 10V In Control, 20 mA In Control, Analog Invert 28 settings; Not Used, Accel 2 & Decel 2, Jog, Auxiliary Fault, Preset Frequencies, Local, Comm Port, Clear Fault, Ramp Stop - Clear Fault, Coast Stop - Clear Fault, DC Brake - Clear Fault, Jog Forward, Jog Reverse, 10V In Control, 20 mA In Control, PID Disable, MOP Up, MOP Down, Timer Start, Counter In, Reset Timer, Reset Counter, Reset Timer and Counter, Logic In1, Logic In2, Current Limit2, Analog Invert, EM Brake Release	Preset Freq

Shaded areas are applicable to PowerFlex 40 only.

PowerFlex 4 and 40 Technical Data

Parameter Number	Parameter Name	Description	Factory Default
A053	Digital In3 Sel	28 settings; Not Used, Accel 2 & Decel 2, Jog, Auxiliary Fault, Preset Frequencies, Local, Comm Port, Clear Fault, Ramp Stop - Clear Fault, Coast Stop - Clear Fault, DC Brake - Clear Fault, Jog Forward, Jog Reverse, 10V In Control, 20 mA In Control, PID Disable, MOP Up, MOP Down, Timer Start, Counter In, Reset Timer, Reset Counter, Reset Timer and Counter, Logic In1, Logic In2, Current Limit2, Analog Invert, EM Brake Release	Local
A054	Digital In4 Sel	28 settings; Not Used, Accel 2 & Decel 2, Jog, Auxiliary Fault, Preset Frequencies, Local, Comm Port, Clear Fault, Ramp Stop - Clear Fault, Coast Stop - Clear Fault, DC Brake - Clear Fault, Jog Forward, Jog Reverse, 10V In Control, 20 mA In Control, PID Disable, MOP Up, MOP Down, Timer Start, Counter In, Reset Timer, Reset Counter, Reset Timer and Counter, Logic In1, Logic In2, Current Limit2, Analog Invert, EM Brake Release	Jog Forward
A055	Relay Out Sel	13 different settings for a variety of drive status conditions	Ready/Fault
		24 different settings for a variety of drive status conditions	Ready/Fault
A056	Relay Out Level	0.0 to 9999	0.0
A058	Opto Out1 Sel	24 settings; Ready/Fault, At Frequency, Motor Running, Reverse, Motor Overload, Ramp Regulator, Above Frequency, Above Current, Above DC Voltage, Retries Exceeded, Above Analog Voltage, Logic In1, Logic In2, Logic 1 & 2, Step Logic Out, Timer Out, Counter Out, Above PF Angle, Analog Input Loss, Param Control, Non-Recoverable Fault, EM Brake Control, Above Frequency Command	MotorRunning
A059	Opto Out1 Level	0.0 to 9999	0.0
A061	Opto Out2 Sel	24 settings; Ready/Fault, At Frequency, Motor Running, Reverse, Motor Overload, Ramp Regulator, Above Frequency, Above Current, Above DC Voltage, Retries Exceeded, Above Analog Voltage, Logic In1, Logic In2, Logic 1 & 2, Step Logic Out, Timer Out, Counter Out, Above PF Angle, Analog Input Loss, Param Control, Non-Recoverable Fault, EM Brake Control, Above Frequency Command	At Frequency
A062	Opto Out2 Level	0.0 to 9999	0.0
A064	Opto Out Logic	Determines the logic (NO or NC) of the opto outputs, 4 settings - NO/NO, NC/NO, NO/NC, NC/NC	NO/NO
A065	Analog Out Sel	Sets the analog output signal mode, various settings	Output Freq 0-10, 0V=0Hz
A066	Analog Out High	0 to 800%	100%
A067	Accel Time 2	0.0 to 600.0 seconds	20.0 Secs
A068	Decel Time 2	0.1 to 600.0 seconds	20.0 Secs
A069	Internal Freq	0.0 to 240.0 Hz	60.0 Hz
		0.0 to 400.0 Hz	60.0 Hz
A070	Preset Freq 0	0.0 to 240.0 Hz	0.0 Hz
		0.0 to 400.0 Hz	0.0 Hz
A071	Preset Freq 1	0.0 to 240.0 Hz	5.0 Hz
		0.0 to 400.0 Hz	5.0 Hz
A072	Preset Freq 2	0.0 to 240.0 Hz	10.0 Hz
		0.0 to 400.0 Hz	10.0 Hz
A073	Preset Freq 3	0.0 to 240.0 Hz	20.0 Hz
		0.0 to 400.0 Hz	20.0 Hz
A074	Preset Freq 4	0.0 to 400.0 Hz	30.0 Hz
A075	Preset Freq 5	0.0 to 400.0 Hz	40.0 Hz
A076	Preset Freq 6	0.0 to 400.0 Hz	50.0 Hz
A077	Preset Freq 7	0.0 to 400.0 Hz	60.0 Hz
A078	Jog Frequency	0.0 to (Value set in P035 [Maximum Freq])	10.0 Hz
A079	Jog Accel/Decel	0.1 to 600.0 seconds	10.0 Secs
A080	DC Brake Time	0.0 to 90.0 seconds	0.0 Secs
		0.0 to 99.9 seconds	0.0 Secs
A081	DC Brake Level	0.0 to (Drive Rated Amps x 1.8)	Drive Rated Amps x 0.05
A082	DB Resistor Sel	Used to set percent duty cycle for external dynamic braking	Disabled
A083	S Curve %	0 to 100%	0% (Disabled)
A084	Boost Select	14 boost settings (in % of P031 [Motor NP Volts]), redefines the Volts per Hertz curve	5.0 (2.5 for 5 HP drives)
		15 boost settings (in % of P031 [Motor NP Volts]), redefines the Volts per Hertz curve	5.0, CT (2.5 CT for 5-15 HP drives)
A085	Start Boost	0.0 to 25.0%	2.5%
A086	Break Voltage	0.0 to 100.0%	25.0%
A087	Break Frequency	0.0 to 400.0 Hz	15.0 Hz
A088	Maximum Voltage	20 to Drive Rated Volts	Drive Rated Volts
A089	Current Limit 1	0.1 to (Drive Rated Amps x 1.8)	Drive Rated Amps x 1.5
A090	Motor OL Select	3 settings; No Derate, Minimum Derate, Maximum Derate	No Derate
A091	PWM Frequency	2.0 to 16.0 kHz	4.0 kHz
A092	Auto Rstrt Tries	0 to 9	0
A093	Auto Rstrt Delay	0.0 to 300.0 seconds	1.0 Secs
A094	Start At PowerUp	2 settings; Disabled, Enabled	Disabled
A095	Reverse Disable	2 settings; Reverse Enabled, Reverse Disabled	Rev Enabled

Shaded areas are applicable to PowerFlex 40 only.

PowerFlex 4 and 40 Technical Data

Parameter Number	Parameter Name	Description	Factory Default
<i>Advanced Program Group, Continued</i>			
A096	Flying Start En	2 settings; Disabled, Enabled	Disabled
A097	Compensation	4 settings; Disabled, Electrical, Mechanical, Both	Electrical
A098	SW Current Trip	Software instantaneous trip, 0.0 to (Drive Rated Amps x 2)	0.0 (Disabled)
A099	Process Factor	0.1 to 999.9	30.0
A100	Fault Clear	Resets a fault and clears the fault queue	Ready/Idle
A101	Program Lock	Protects parameters against change by unauthorized personnel	Unlocked
A102	Testpoint Sel	Used by Rockwell Automation field service personnel	400
A103	Comm Data Rate	6 settings; 1200, 2400, 4800, 9600, 19.2K, 38.4K	9600
A104	Comm Node Addr	1 to 247	100
A105	Comm Loss Action	4 settings; Fault, Coast to Stop, Stop, Continue Last Speed	Fault
A106	Comm Loss Time	0.1 to 60.0 seconds	5.0 Secs
A107	Comm Format	6 settings; RTU 8-N-1, RTU 8-E-1, RTU 8-O-1, RTU 8-N-2, RTU 8-E-2, RTU 8-O-2	RTU 8-N-1
A108	Language	10 settings; English, Francais, Espanol, Italiano, Deutsch, Reserved, Portugues, Reserved, Reserved, Nederlands	English
A109	Anlg Out Setpt	0.0/100.0%	100.0%
A110	Anlg In 0-10V Lo	0.0 to 100.0%	0.0%
A111	Anlg In 0-10V Hi	0.0 to 100.0%	100.0%
A112	Anlg In4-20mA Lo	0.0 to 100.0%	0.0%
A113	Anlg In4-20mA Hi	0.0 to 100.0%	100.0%
A114	Slip Hertz @ FLA	0.0 to 10.0 Hz	2.0 Hz
A115	Process Time Lo	0.00 to 99.99	0.00
A116	Process Time Hi	0.00 to 99.99	0.00
A117	Bus Reg Mode	0/1	Enabled
A118	Current Limit 2	0.1 to (Drive Rated Amps x 1.8)	Drive Rated Amps x 1.5
A119	Skip Frequency	0 to 400 Hz	0 Hz
A120	Skip Freq Band	0.0 to 30.0 Hz	0.0 Hz
A121	Stall Fault Time	6 settings; 60 Seconds, 120 Seconds, 240 Seconds, 360 Seconds, 480 Seconds, Fit Disabled	60 Seconds
A122	Analog In Loss	7 settings; Disabled, Fault (F29), Stop, Zero Ref, Min Freq Ref, Max Freq Ref, Int Freq Ref	Disabled
A123	10V Bipolar Enbl	2 settings; Uni-Polar In, Bi-Polar In	Uni-Polar In
A124	Var PWM Disable	2 settings; Enabled, Disabled	Enabled
A125	Torque Perf Mode	2 settings; V/Hz, Sensorless Vector	Sensrls Vect
A126	Motor NP FLA	Drive Rated Amps x 0.1/2	Drive Rated Amps
A127	Autotune	3 settings; Ready/Idle, Static Tune, Rotate Tune	Ready/Idle
A128	IR Voltage Drop	0.0 to 230.0 VAC	Based on Drive Rating
A129	Flux Current Ref	0.00 to Motor NP FLA	Based on Drive Rating
A130	PID Trim Hi	0.0 to 400.0	60.0
A131	PID Trim Lo	0.0 to 400.0	0.0
A132	PID Ref Sel	9 settings; PID Disabled, PID Setpoint, 0-10V Input, 4-20mA Input, Comm Port, Setpoint - Trim, 0-10V - Trim, 4-20mA - Trim, Comm - Trim	PID Disabled
A133	PID Feedback Sel	3 settings; 0-10V Input, 4-20mA Input, Comm Port	0-10V Input
A134	PID Prop Gain	0.00 to 99.99	0.01
A135	PID Integ Time	0.0 to 999.9 Seconds	0.1 Secs
A136	PID Diff Rate	0.00 to 99.99 (1/Secs)	0.01 (1/Secs)
A137	PID Setpoint	0.0 to 100.0%	0.0%
A138	PID Deadband	0.0 to 10.0%	0.0%
A139	PID Preload	0.0 to 400.0 Hz	0.0 Hz
A140-A147	Stp Logic 0-7	0001 to bAFF	00F1
A150-157	Stp Logic Time 0-7	0.0 to 999.9 Seconds	30.0 Secs
A160	EM Brk Off Delay	0.01/10.00 Secs	2.00 Secs
A161	EM Brk On Delay	0.01/10.00 Secs	2.00 Secs
A162	MOP Reset Sel	2 settings; Zero MOP Ref, Save MOP Ref	Save MOP Ref
A163	DB Threshold	0.0 to 110.0%	100.0%
A164	Comm Write Mode	2 settings; Save, RAM Only	Save
A165	Anlg Loss Delay	0.0 to 20.0 Secs	0.0 Secs
A166	Analog In Filter	0 to 14	0

Shaded areas are applicable to PowerFlex 40 only.

Product Dimensions

Approximate Dimensions

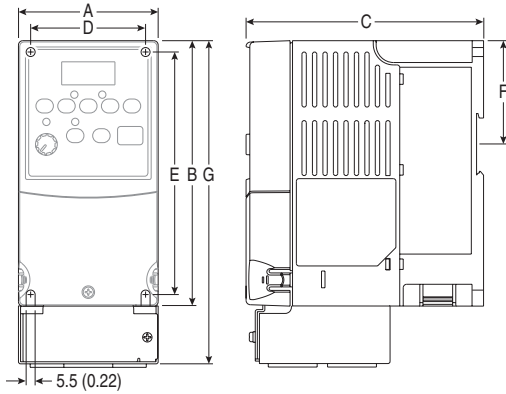

Dimensions are in millimeters and (inches). Weights are in kilograms and (pounds).

Frame	A	B ❶	C	D	E	F	G ❷	Shipping Weight
A	80 (3.15)	152 (5.98)	136 (5.35)	67 (2.64)	140 (5.51)	59.3 (2.33)	185 (7.28)	1.4 (3.1)
B	100 (3.94)	180 (7.09)	136 (5.35)	87 (3.43)	168 (6.61)	87.4 (3.44)	213 (8.39)	2.2 (4.9)
C	130 (5.1)	260 (10.2)	180 (7.1)	116 (4.57)	246 (9.7)	–	320 (12.6)	4.3 (9.5)

- ❶ Overall height of standard IP 20/Open Type Drive.
- ❷ Overall height of drive with IP 30/NEMA 1/UL Type 1 option kit installed.

Ratings are in kW and (HP).

PowerFlex 4 — Frame	120V AC – 1-Phase	240V AC – 1-Phase	240V AC – 3-Phase	480V AC – 3-Phase
A	0.2 (0.25) 0.4(0.5)	0.2 (0.25) 0.4 (0.5) 0.75 (1.0)	0.2 (0.25) 0.4 (0.5) 0.75 (1.0) 1.5 (2.0)	0.4 (0.5) 0.75 (1.0) 1.5 (2.0)
B	0.75 (1.0) 1.1 (1.5)	1.5 (2.0)	2.2 (3.0) 3.7 (5.0)	2.2 (3.0) 3.7 (5.0)

PowerFlex 40 — Frame	120V AC – 1-Phase	240V AC – 1-Phase	240V AC – 3-Phase	480V AC – 3-Phase	600V AC – 3-Phase
B	0.4 (0.5) 0.75 (1.0) 1.1 (1.5)	0.4 (0.5) 0.75 (1.0) 1.5 (2.0)	0.4 (0.5) 0.75 (1.0) 1.5 (2.0) 2.2 (3.0) 3.7 (5.0)	0.4 (0.5) 0.75 (1.0) 1.5 (2.0) 2.2 (3.0) 4.0 (5.0)	0.75 (1.0) 1.5 (2.0) 2.2 (3.0) 4.0 (5.0)
C		2.2 (3.0)	5.5 (7.5) 7.5 (10.0)	5.5 (7.5) 7.5 (10.0) 11.0 (15.0)	5.5 (7.5) 7.5 (10.0) 11.0 (15.0)

Shaded areas are applicable to PowerFlex 40 only.

Flange Mount Drive

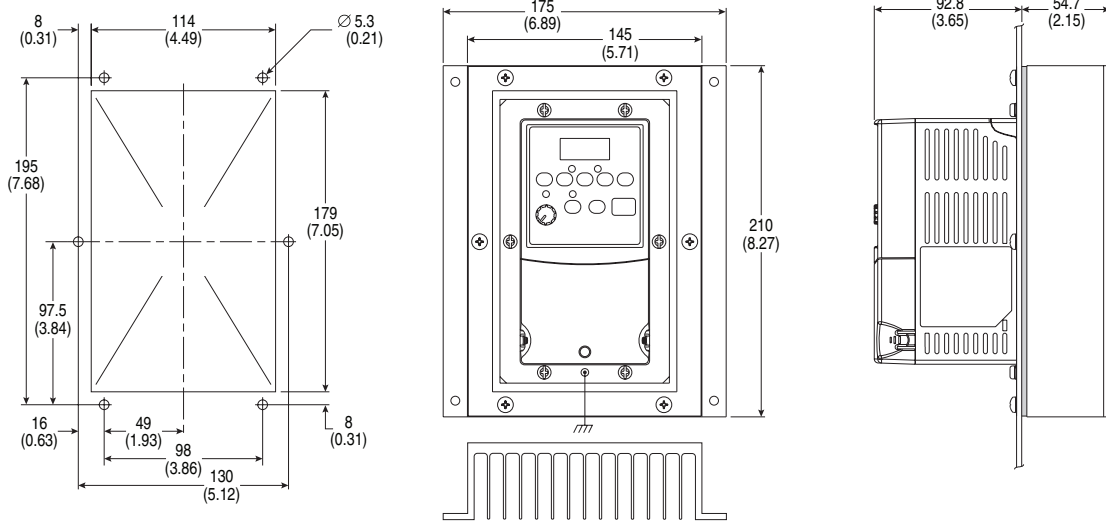

Frame A — PowerFlex 4 only

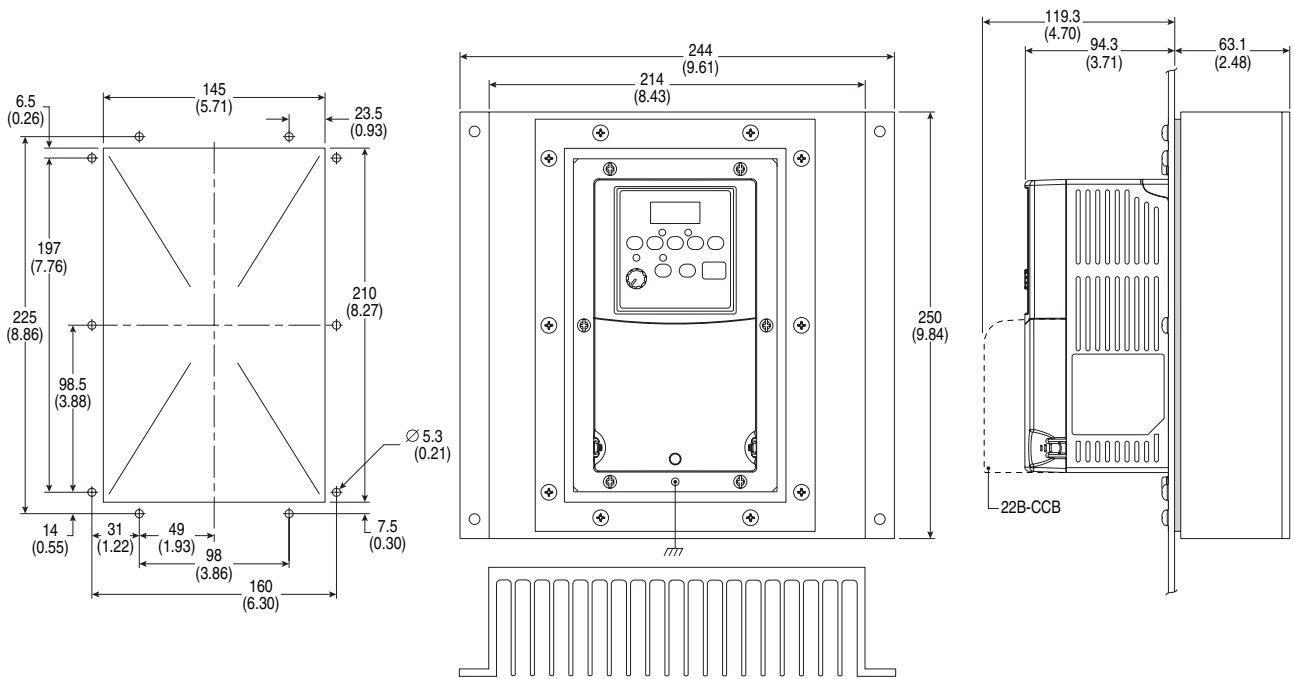

Frame B — PowerFlex 4 and PowerFlex 40

Shaded areas are applicable to PowerFlex 40 only.

Flange Mount Drive *Continued*

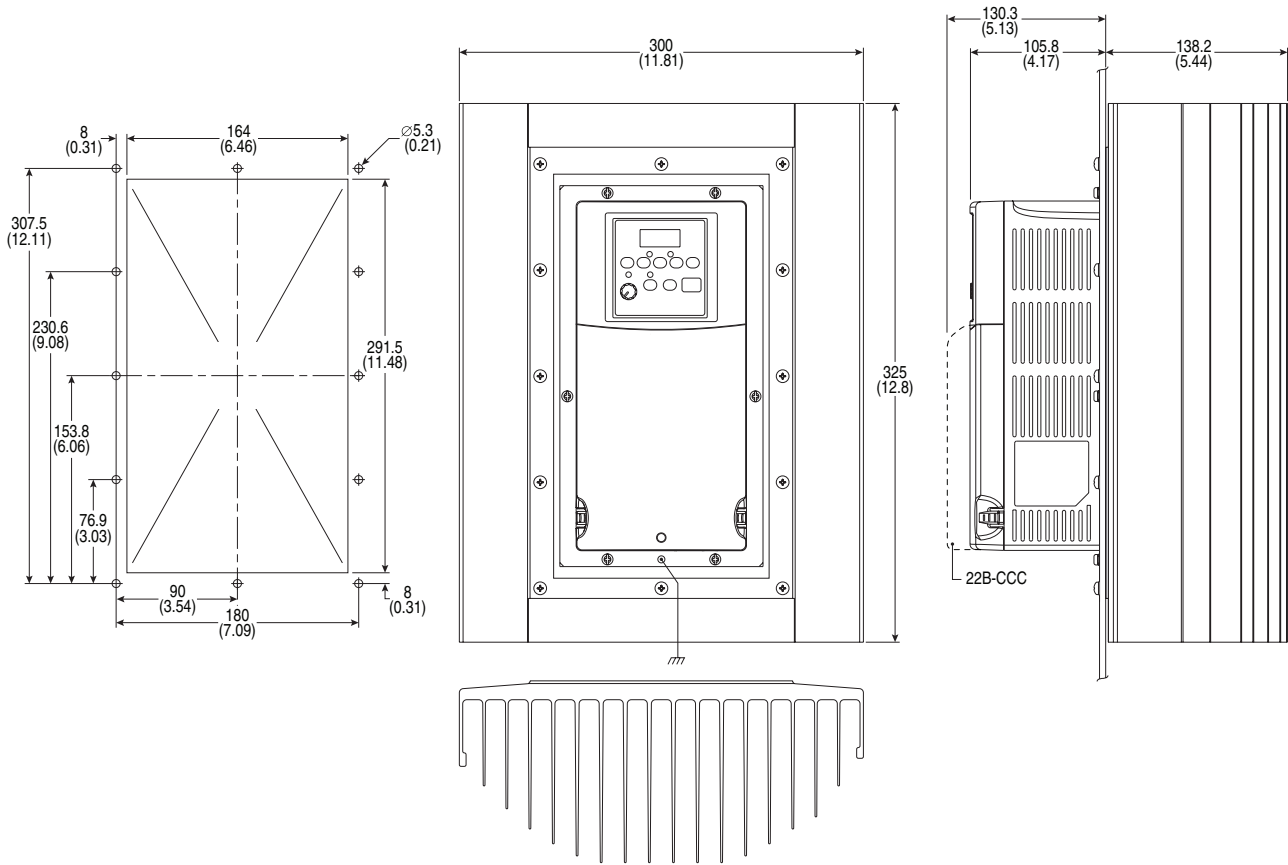

Frame C—PowerFlex 40 only

IP 66, NEMA/UL Type 4X/12

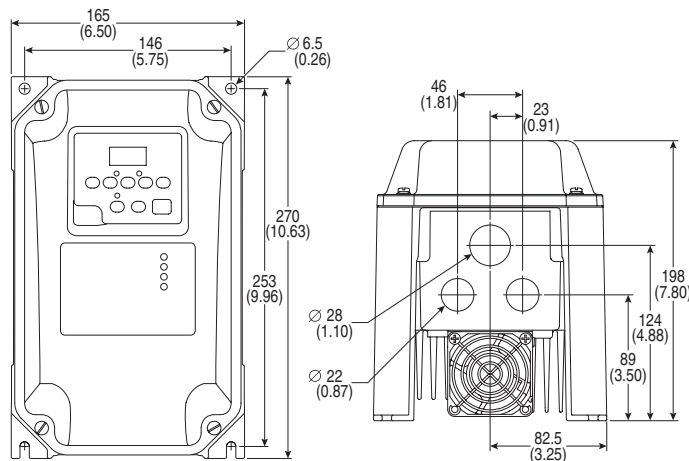

Frame B—PowerFlex 40 only

Shaded areas are applicable to PowerFlex 40 only.

IP 30, NEMA/UL Type 1 Option Kit without Communication Options

PowerFlex 4 uses Frames A & B. PowerFlex 40 uses Frames B & C.

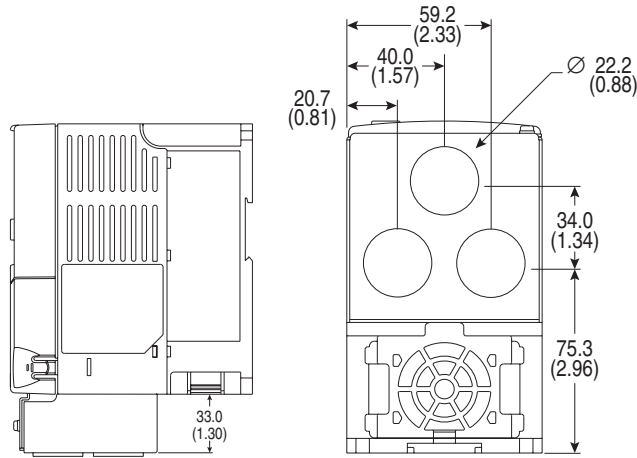

Frame A — 22-JBAA

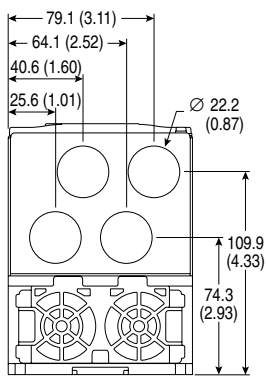
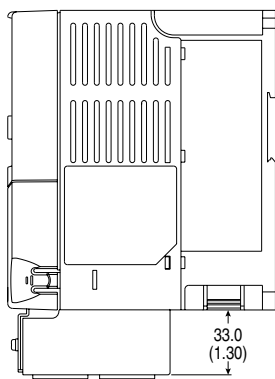

Frame B — 22-JBAB

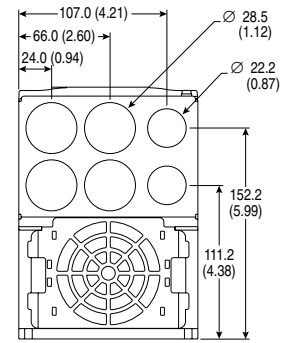
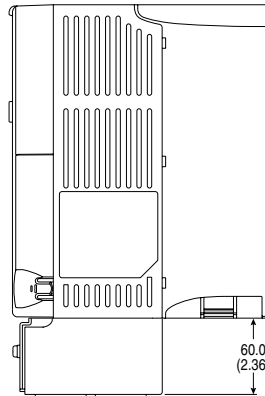

Frame C — 22-JBAC

PowerFlex 40 IP 30/NEMA 1/UL Type 1 Option Kit with Communication Option

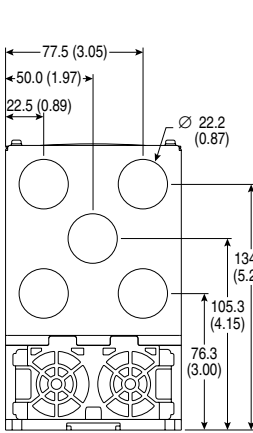
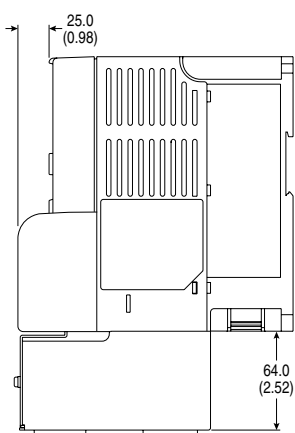

Frame B — 22-JBCB

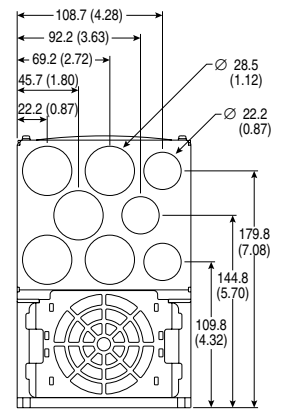
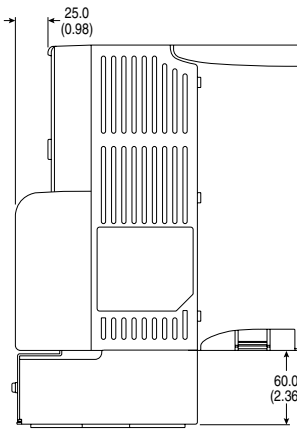

Frame C — 22-JBCC

Shaded areas are applicable to PowerFlex 40 only.

Dynamic Brake Resistors

Dimensions are in millimeters and (inches)

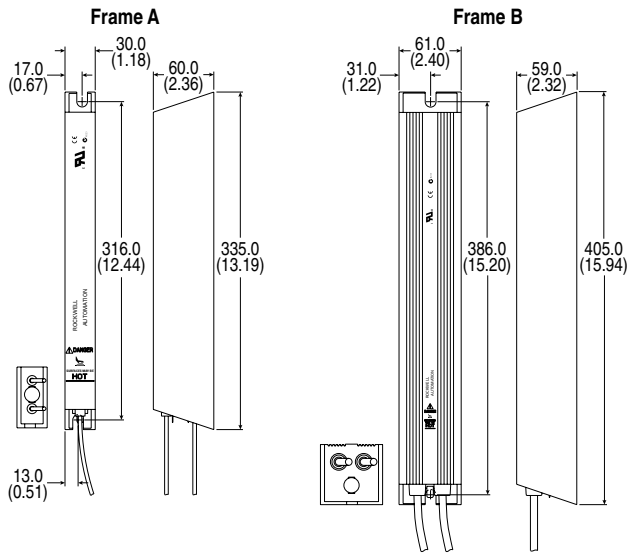

Frame	Catalog Number
A	AK-R2-091P500, AK-R2-047P500, AK-R2-360P500
B	AK-R2-030P1K2, AK-R2-120P1K2

Bulletin 1321-3R Series Line Reactors

Dimensions are in millimeters and (inches). Weights are in kilograms and (pounds).

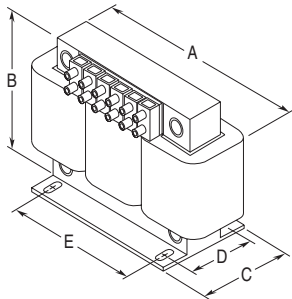

Catalog Number	A	B	C	D	E	Weight
1321-3R2-A	112 (4.40)	104 (4.10)	70 (2.75)	50 (1.98)	37 (1.44)	1.8 (4)
1321-3R2-B	112 (4.40)	104 (4.10)	70 (2.75)	50 (1.98)	37 (1.44)	1.8 (4)
1321-3R4-A	112 (4.40)	104 (4.10)	76 (3.00)	50 (1.98)	37 (1.44)	1.8 (4)
1321-3R4-B	112 (4.40)	104 (4.10)	76 (3.00)	50 (1.98)	37 (1.44)	1.8 (4)
1321-3R4-C	112 (4.40)	104 (4.10)	86 (3.38)	60 (2.35)	37 (1.44)	2.3 (5)
1321-3R8-A	152 (6.00)	127 (5.00)	76 (3.00)	53 (2.10)	51 (2.00)	3.1 (7)
1321-3R8-B	152 (6.00)	127 (5.00)	76 (3.00)	53 (2.10)	51 (2.00)	3.6 (8)
1321-3R8-C	152 (6.00)	127 (5.00)	85 (3.35)	63 (2.48)	51 (2.00)	4.9 (11)
1321-3R12-A	152 (6.00)	127 (5.00)	76 (3.00)	53 (2.10)	51 (2.00)	4.1 (9)
1321-3R12-B	152 (6.00)	127 (5.00)	76 (3.00)	53 (2.10)	51 (2.00)	4.5 (10)
1321-3R18-A	152 (6.00)	133 (5.25)	79 (3.10)	54 (2.13)	51 (2.00)	4.1 (9)
1321-3R18-B	152 (6.00)	133 (5.25)	86 (3.40)	63 (2.48)	51 (2.00)	5.4 (12)
1321-3R25-A	183 (7.20)	146 (5.76)	85 (3.35)	60 (2.35)	76 (3.00)	4.9 (11)
1321-3R35-A	193 (7.60)	146 (5.76)	91 (3.60)	66 (2.60)	76 (3.00)	6.3 (14)

Shaded areas are applicable to PowerFlex 40 only.

EMC Line Filters

Frame A EMC Line Filters – Dimensions are in millimeters and (inches)
 Catalog Numbers: 22-RF5P7-AS, -AL; 22-RF9P5-AS, -AL; 22-RF010-AL

Frame B EMC Line Filters – Dimensions are in millimeters and (inches)
 Catalog Numbers: 22-RF8P0-BL, 22-RF012-BS, -BL; 22-RF018-BL;
 22-RF021-BS, -BL

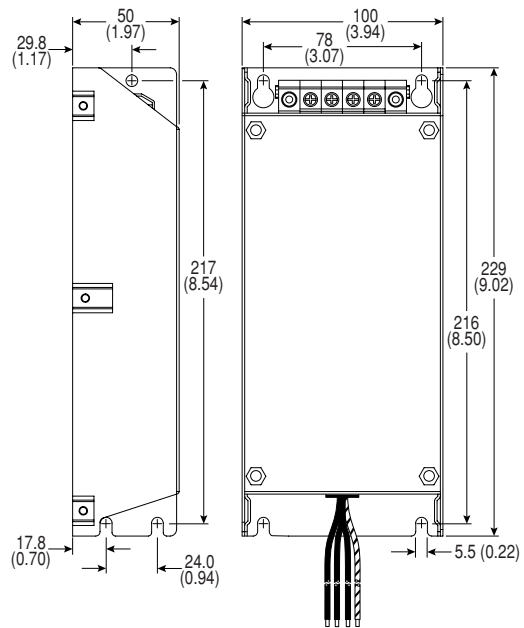
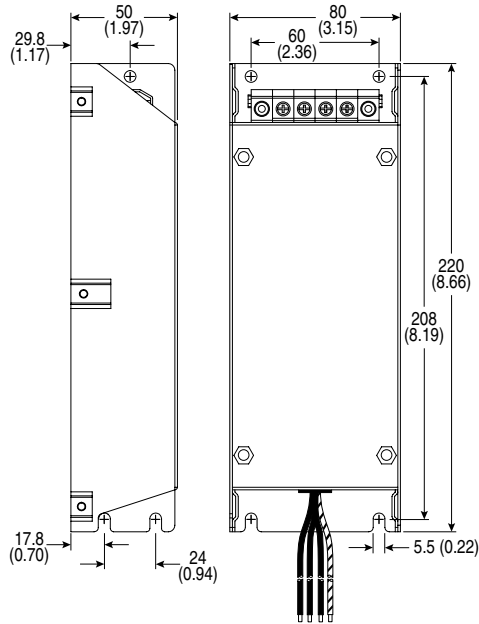

Frame C EMC Line Filters – Dimensions are in millimeters and (inches)
 Catalog Numbers: 22-RF015-CL; 22-RF018-CS, -CL; 22-RF024-CL; 22-RF025-CL; 22-RF026-CS, -CL; 22RF034-CS, -CL

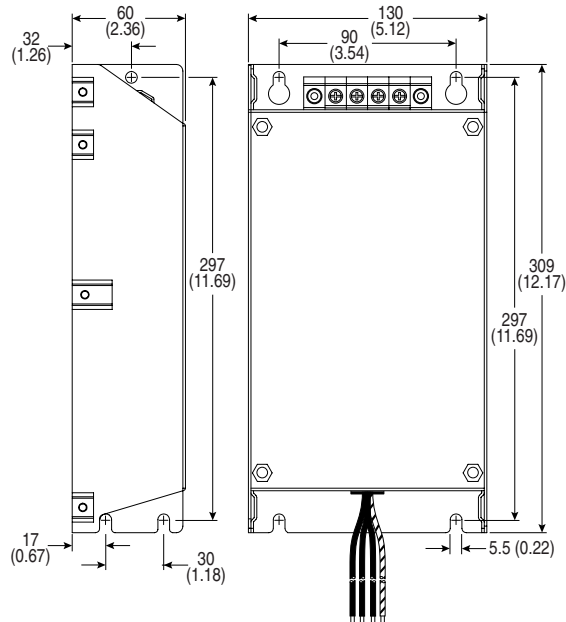

Shaded areas are applicable to PowerFlex 40 only.

Human Interface Module (HIM) Dimensions

NEMA Type 1 Bezel – Dimensions are in millimeters and (inches)
 Catalog Number: 22-HIM-B1

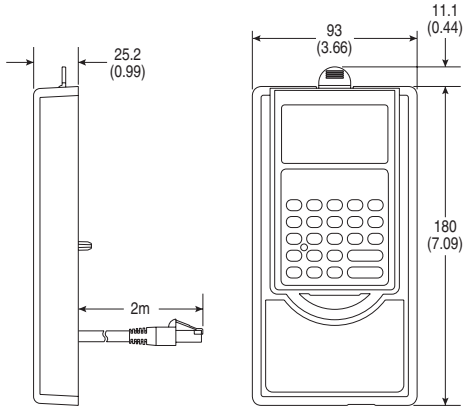

NEMA Type 4X/12 Remote (Panel Mount) HIM
 – Dimensions are in millimeters and (inches)
 Catalog Number: 22-HIM-C2S

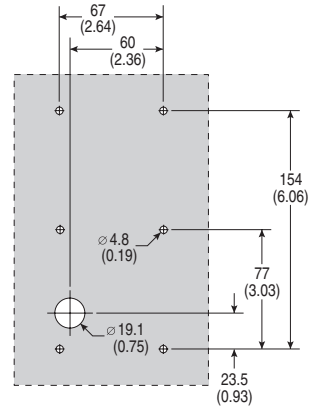
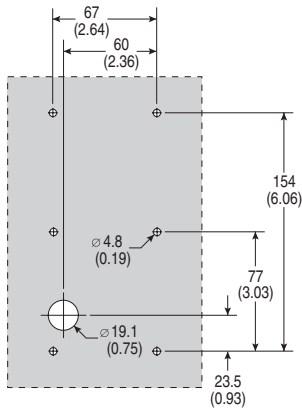
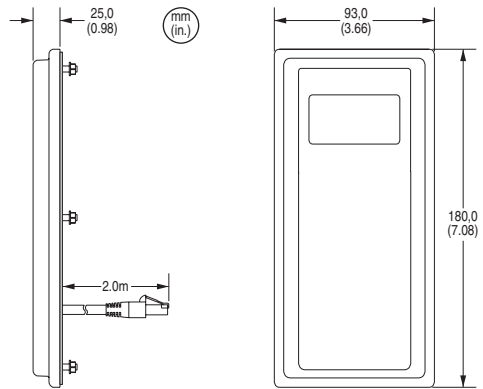

PowerFlex 4 and 40 Configured Drives

The heart of every Configured Drive is an Allen-Bradley standard drive. These world class products help to provide a single solution for virtually all of your motor speed control requirements.

Configured Drive programs provide you with an offering of factory mounted options enhancing the Standard Drive program. The options defined within the programs are pre-engineered for consistency of design. This translates to time and money savings in set-up, integration and maintenance of your automation systems.

Catalog Number Explanation

1-3			4	5	6-8			Position				13	14	15	16+
23B			-	D	4P0			D	1	0	4	N	N	-	P6
<i>a</i>				<i>b</i>	<i>c</i>			<i>d</i>	<i>e</i>	<i>f</i>	<i>g</i>	<i>h</i>	<i>i</i>		<i>j</i>
a															
Drive															
Code	Type														
23B	PowerFlex 40														
b															
Voltage Rating															
Code	Voltage	Ph.													
D	480V ac	3													
c															
Amp Rating															
480V 60Hz Input															
Code	Amps	kW (Hp)													
1P4	1.4	0.4 (0.5)													
2P3	2.3	0.75 (1.0)													
4P0	4.0	1.5 (2.0)													
6P0	6.0	2.2 (3.0)													
010	10.5	4.0 (5.0)													
012	12	5.5 (7.5)													
017	17	7.5 (10)													
024	24	11 (15)													
d															
Enclosure															
Code	Enclosure														
C	NEMA/UL Type 4X ‡														
D	NEMA/UL Type 4 ‡														
‡ The design of the PowerFlex 40 Standard Configured Drive supports indoor and outdoor applications that are not in direct sunlight.															
e															
HIM															
Code	Interface Module														
1	Fixed Keypad on Drive														
F *	Fixed Keypad on Drive and LCD Display with Digital Speed Control HIM on Enclosure Door (22-HIM-C2S)														
* This option changes the enclosure rating to indoor only.															
f															
Emission Class															
Code	Rating														
0	Not Filtered														
g															
Version															
Code	Version														
4	RS485 (Standard)														
C	ControlNet														
D	DeviceNet														
E	EtherNet/IP														
P	PROFIBUS DP														
h															
Rating															
Code	Rating														
N	Reserved														
i															
Rating															
Code	Rating														
N	Reserved														
j															
Options															
Code	Description														
-E22	DeviceNet Quick Disconnect (Bottom)														
-E23	DeviceNet Quick Disconnect (Left Side)														
-P3	Motor Circuit Protector														
-P3T	Motor Circuit Protector (Customer wiring into top of device)														
-P6	Disconnect Switch - Fused														
-P6T	Disconnect Switch - Fused (Customer wiring into top of device)														
-R3	DeviceNet I/O (4 In/2 Out) w/Spring Return HOA and Power Disconnect Aux. Contact														
-R4	DeviceNet Point I/O w/IB4 (4 Inputs)														
-R5	-R3 plus 4 I/O Quick Disconnects and (1) 24V DC Receptacle														
-S1	Hand/Off/Auto S.S. (Start/Stop/Speed Ref.)														
-S4	Auto/Manual S.S. (Speed Ref.)														
-S7	Start and Stop P.B.														
-S8	Forward/Reverse S.S.														
-S18	Door Mounted Local Speed Pot (1-Turn)														
-S20	Local/Remote and Local Control Off/Run Forward Selector Switches														
-S21	Local/Off/Remote with 1 N.O. Interposing Relay														
-S22	Spring Return Hand/Off Auto S.S. (Start/Stop/Speed Ref.)														
-S23	Clear Fault P.B.														

Product Description

PowerFlex 40 Configured AC drives are ideal for OEM's and end-users with special installation needs. Designed to meet your customer demand for space savings, applications flexibility and reliability, the PowerFlex 40 Configured AC drive options have been pre-engineered to ensure superior reliability.

Standard Features

- This package integrates the PowerFlex 40 Standard Drive as the base power/control component.
- Enclosure features include...
 - NEMA Type 4/12 and 4X (IP66) indoor and outdoor applications ❶
 - Heat out the back design reduces enclosure size
 - Viewing window-drive display and all indicators are visible.
 - Mounting feet-orientation is adjustable per customer requirements
- The drive can be removed from the front of the enclosure for ease of assembly or repair.
- Low cost, highly configurable I/O inputs and/or 0-10V/4-20mA outputs that are not used by program standard features and options are available for customer use.
- ❶ Supports indoor and outdoor applications other than direct sunlight.





Program Options

- Communication Options
 - ControlNet
 - DeviceNet
 - EtherNet/IP
 - LonWorks
 - PROFIBUS DP
- Power Disconnect Options
 - Drive Input Fused Disconnect Switch – 100kA short circuit withstand rating
 - Motor Circuit Protector – 65kA short circuit withstand rating
- Door Mounted Operator Devices
 - Hand/Off/Auto Selector Switch
 - Auto/Manual Selector Switch
 - Start and Stop Pushbuttons
 - Forward/Reverse Selector Switch
 - Local Control Off/Run Forward and Local/Remote – Selector Switches
 - Local/Off/Remote Selector Switch with One – Normally Open Interposing Relay–(Panel)
 - Clear Fault Pushbutton
- Quick Disconnect
 - DeviceNet Quick Disconnect–Bottom or left side mounted
- I/O Options
 - DeviceNet I/O with Hand/Off auto selector switch and power disconnect auxiliary contact. (4 in / 2 out) I/O quick disconnect optional.
 - DeviceNet Point I/O with IB4 (4 in)

For option specific detail, refer to the PowerFlex 40 Adjustable Frequency AC Configured Drives Installation Instructions, publication 23B-IN001....

Drive Ratings — PowerFlex 40 Configured Drives					
Catalog Number	kW (HP)	Input Ratings		Output Ratings	
		Voltage	Amps	Voltage	Amps
23B-D1P4	0.4 (0.5)	480	1.8	460	1.4
23B-D2P3	0.75 (1.0)	480	3.2	460	2.3
23B-D4P0	1.5 (2.0)	480	5.7	460	4.0
23B-D6P0	2.2 (3.0)	480	7.5	460	6.0
23B-D010	4.0 (5.0)	480	13.0	460	10.5
23B-D012	5.5 (7.5)	480	14.2	460	12.0
23B-D017	7.5 (10.0)	480	18.4	460	17.0
23B-D024	11.0 (15.0)	480	26.0	460	24.0

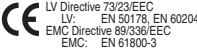
Specifications for Configured Drive Products

Input/Output Ratings	Output Frequency: Efficiency:	0-400 Hz (Programmable) 97.5% (Typical)
Approvals	 UL508C  CSA C 22.2 No. 14  EN 61800-3 	
Fuses and Power Disconnecting Means	140M Motor Circuit Protector: 194R Fused Disconnect:	Provides branch circuit protection, 65 kA short circuit withstand Provides branch circuit protection, 100 kA short circuit withstand, Class J fuses
Protective Features	Over Voltage: Under Voltage:	480V AC Input – Trip occurs at 810V DC bus voltage (equivalent to 575V AC incoming line) 480V AC Input – Trip occurs at 390V DC bus voltage (equivalent to 275V AC incoming line)
Environment	Ambient Operating Temperature: Cooling Method:	NEMA 4/12, 4X (IP66), –10 to 40 degrees C (14 to 104 degrees F)  Fan, all drive ratings
Control	Carrier Frequency:	2-4 kHz. Drive rating and heat calculations are based on 4 kHz.

 The design of the PowerFlex 40 Configured Drive supports indoor and outdoor applications that are not in direct sunlight.

Specifications for Standard PowerFlex 40 Drives

Electrical	Voltage Tolerance: Frequency Tolerance: Displacement Power Factor: Maximum Short Circuit Rating:	120V, 200-240V, 380-480V, 460-600V: ±10% 48-63 Hz 0.98 across entire speed range 100,000 Amps symmetrical
Control Inputs	Digital SRC (Source) Mode: SNK (Sink) Mode: Analog 4-20 mA Analog: 0-10V DC Analog: External Pot:	Input Current = 6 mA 18-24V = On, 0-6V = Off 0-6V = On, 18-24V = Off 250 ohm input impedance 100k ohm input impedance 1-10k ohms, 2 Watt minimum
Control Output – Programmable Outputs (form C relay)	Resistive Rating Opto Outputs: Analog Outputs: Inductive Rating Opto Outputs: Analog Outputs:	3.0A at 30V DC, 3.0A at 125V AC, 3.0A at 240V AC 30V DC, 50 mA 10-bit, 0-10V, 1k ohm minimum 0.5A at 30V DC, 0.5A at 125V AC, 0.5A at 240V AC Non-inductive 10 bit, 4-20 mA, 525 ohm maximum
Fuses and Circuit Breakers	Recommended Fuse Type: Recommended Circuit Breakers:	UL Class J, CC, T or Type BS88; 600V (550V) or equivalent. HMCP circuit breaker or equivalent.
Protective Features	Motor Protection: Overcurrent: Control Ride Through: Faultless Power Ride Through:	1 $\frac{1}{2}$ Overload Protection, 150% for 60 sec., 200% for 3 sec. (provides Class 10 protection) 200% hardware limit, 300% instantaneous fault Minimum Ride Through is 0.5 sec. - typical value is 2 seconds 100 milliseconds
Dynamic Braking	Internal brake IGBT included with all ratings.	
Environment	Altitude: Storage Temperature: Atmosphere: Relative Humidity: Shock (operating): Vibration (operating):	1000 m (3300 ft.) maximum without derating –40 to 85 degrees C (–40 to 185 degrees F) Important: Drive must not be installed in an area where the ambient atmosphere contains volatile or corrosive gas, vapors or dust. If the drive is not going to be installed for a period of time, it must be stored in an area where it will not be exposed to a corrosive atmosphere. 0 to 95% non-condensing 15G peak for 11ms duration (±1.0ms) 1G peak, 5 to 2000 Hz
Control	Frequency Accuracy: Speed Regulation: Stop Modes: Accel/Decel: Intermittent Overload: Electronic Motor Overload Protection:	Digital Input: Within ±0.05% of set output frequency. Analog Input: Within 0.5% of maximum output frequency. Analog Output: ±2% of full scale, 10-bit resolution. Open Loop with Slip Compensation: ±2% of base speed across a 40:1 speed range. 1% of base speed across a 60:1 speed range. Multiple programmable stop modes including - Ramp, Coast, DC-Brake, Ramp-to-Hold and S Curve. Two independently programmable accel and decel times. Each time may be programmed from 0-600 seconds in 0.1 second increments. 150% overload capability for up to 1 minute, 200% overload capability for up to 3 seconds. Class 10 protection with speed sensitive response.

Enclosure Options and Approximate Dimensions

Frame B Dimensions

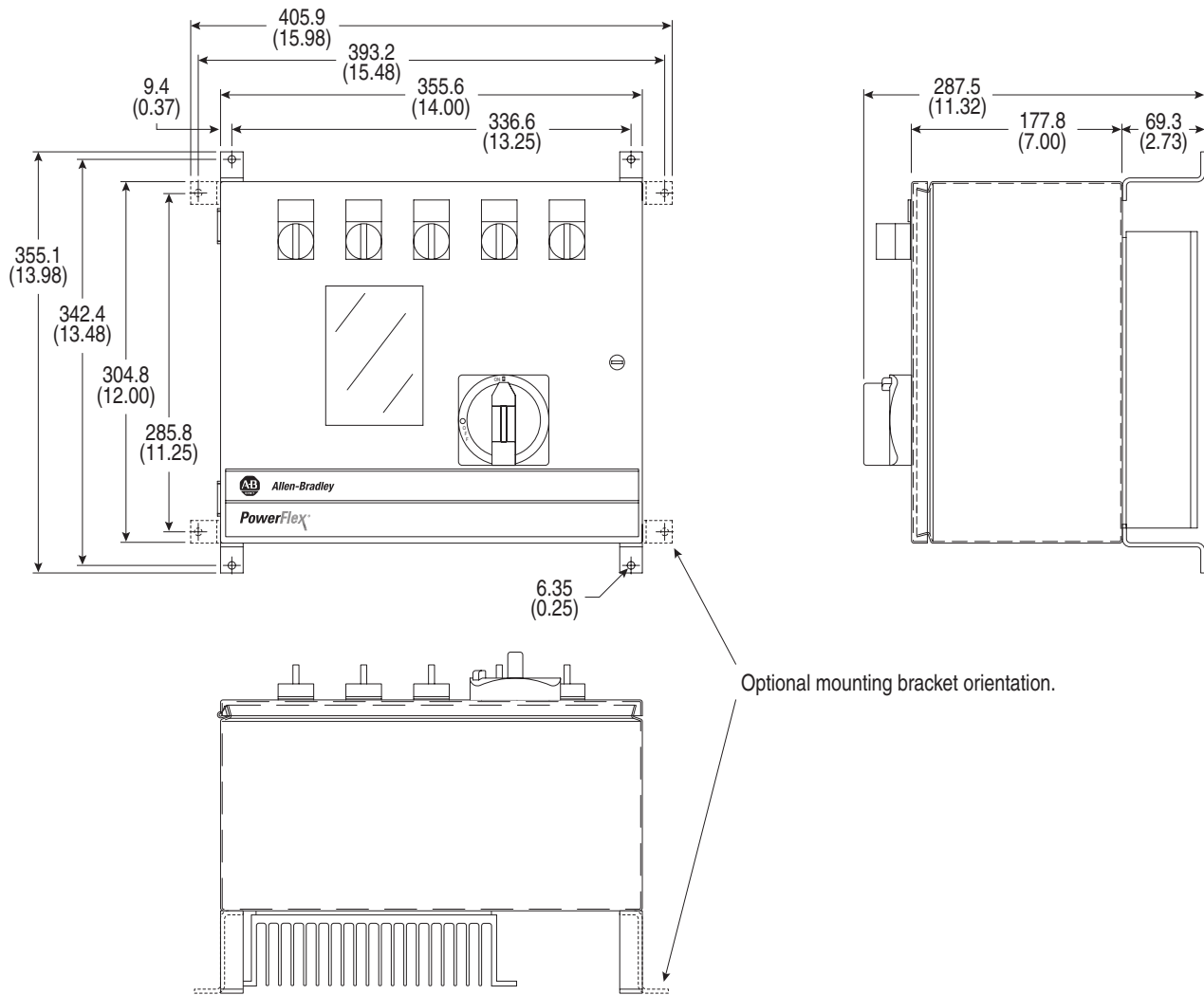

Frame C Dimensions

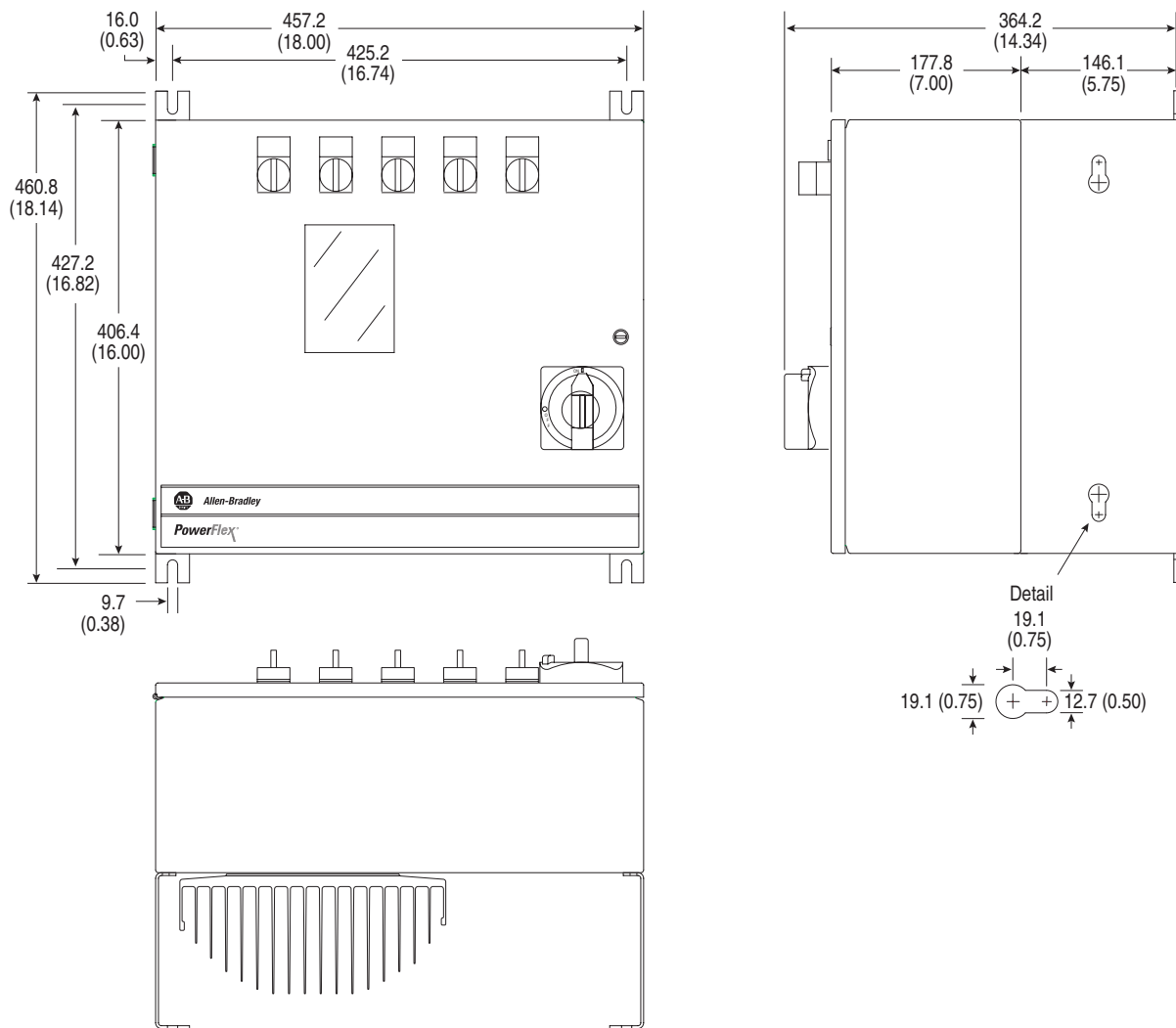

PowerFlex, Zero Stacking, Force Technology, DriveExplorer, DriveTools SP, DPI and PanelView are trademarks of Rockwell Automation.
Trademarks not belonging to Rockwell Automation are property of their respective companies.

www.rockwellautomation.com

Power, Control and Information Solutions Headquarters

Americas: Rockwell Automation, 1201 South Second Street, Milwaukee, WI 53204 USA, Tel: (1) 414.382.2000, Fax: (1) 414.382.4444

Europe/Middle East/Africa: Rockwell Automation, Vorstlaan/Boulevard du Souverain 36, 1170 Brussels, Belgium, Tel: (32) 2 663 0600, Fax: (32) 2 663 0640

Asia Pacific: Rockwell Automation, Level 14, Core F, Cyberport 3, 100 Cyberport Road, Hong Kong, Tel: (852) 2887 4788, Fax: (852) 2508 1846