



1305 Adjustable Frequency AC Drive

Reference Guide
FRN 6.01 and Up



ATTENTION: This publication is designed as a reference tool. The 1305 User Manual (publication 1305-5.2) must be consulted for more detailed information about parameters, faults and hazards of personal injury.

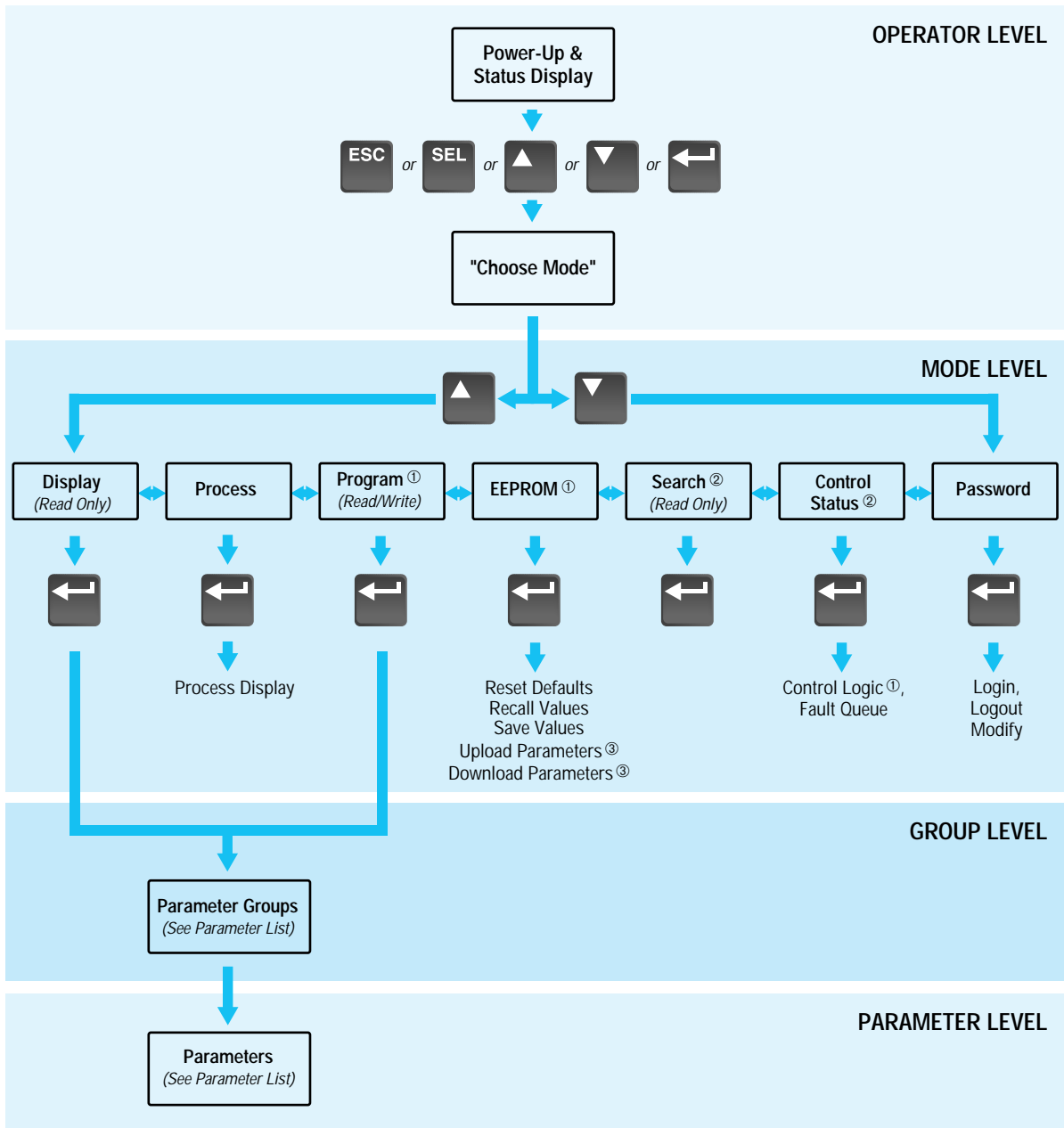

① Access to the Program and EEPROM modes, and the Control Logic and Clear Fault Queue, are disabled if the password is Logged Out.

② Series A HIM Software Version 3.00 & Above or Series B HIM Software Version 1.01 & Above Only.

③ Series B HIM Software Version 1.01 & Above Only.

1305 Series C Parameter List

Group/ Parameter	No.	Units	Min. Value	Max. Value	Default Value
Metering					
Output Current	54	0.01 Amps	0.00	2x Drive Output Curr.	—
Output Voltage	1	1 Volt	0	Maximum Voltage	—
Output Power	23	0.01 kW	0.00	2x Rtd. Dr. Output Pwr.	—
DC Bus Voltage	53	1 Volt	0	410 - 230V Drive 815 - 460V Drive	—
Output Freq.	66	0.01 Hz	0.00	Maximum Freq.	—
Freq. Command	65	0.01 Hz	0.00	+400.00	0.00
MOP Hz	42	0.01 Hz	0.00	400.00	—
Drive Temp	70	1 deg. C	0	100	—
Last Fault	4	Numeric	0	Max Fault No.	—
% Output Power	3	1%	0	200% Drive Rtd. Pwr.	—
% Output Curr.	2	1%	0	200% Rtd. Dr. Out. Curr.	—
Setup					
Input Mode	21	Text ⊕	—	—	Three Wire
Freq Select 1	5	Text ⊕	—	—	Adapter 1
Accel Time 1	7	0.1 Sec	0.0	3600.0	10.0
Decel Time 1	8	0.1 Sec	0.0	3600.0	10.0
Base Frequency	17	1 Hz	40	400	60
Base Voltage	18	1 Volt	25% of DRV	100% of Max DRV	Max DRV
Maximum Voltage	20	1 Volt	25% of DRV	110% of Max DRV	Max DRV
Minimum Freq	16	1 Hz	0	120	0
Maximum Freq	19	1 Hz	40	400	60
Stop Select	10	Text ⊕	—	—	Ramp
Current Limit	36	1%	20% of DRC	150% of DRC	150% of DRC
Overload Mode	37	Text ⊕	—	—	No Derating
Overload Current	38	0.1 Amps	20% of DRC	115% of DRC	115% of DRC
Sec Curr Limit	141	1%	0% of DRC	150% of DRC	0% of DRC
Adaptive I Lim	149	Text ⊕	—	—	Enabled
Advanced Setup					
Minimum Freq	16	1 Hz	0	120	0
Maximum Freq	19	1 Hz	40	400	60
Base Frequency	17	1 Hz	40	400	60
Base Voltage	18	1 Volt	25% Max DRV	100% of Max DRV	Max DRV
Break Frequency	49	1 Hz	0	120	30
Break Voltage	50	1 Volt	0	50% of Max DRV	Dr. Size. Dep.
Maximum Voltage	20	1 Volt	25% Max DRV	110% of Max DRV	Max DRV
DC Boost Select	9	Text ⊕	—	—	Break Point
Start Boost	48	1 Volt	0	25% of Max DRV	Dr. Size Dep.
Run Boost	83	1 Volt	0	25% of Max DRV	0
PWM Frequency	45	0.1 kHz	2.0	8.0	4.0
Analog Invert	84	Text ⊕	—	—	Disabled
4-20mA Loss Sel	81	Text ⊕	—	—	Stop/Fault
Stop Select	10	Text ⊕	—	—	Ramp
DC Hold Time	12	0.1 Sec	0.0	150.0	0.0
DC Hold Volts	13	1 Volt	0	25% of Max DRV	0
DB Enable	11	Text ⊕	—	—	Disabled
Motor Type	41	Text ⊕	—	—	Induc/Reluc
Compensation	52	Text ⊕	—	—	Comp
Frequency Set					
Freq Select 1	5	Text ⊕	—	—	Adapter 1
Freq Select 2	6	Text ⊕	—	—	Remote Pot
Jog Frequency	24	0.1 Hz	0.0	400.0	10.0
Prst/2nd Accel	26	Text ⊕	—	—	Preset
Upper Presets	72	Text ⊕	—	—	Disabled
Accel Time 2	30	0.1 Sec	0.0	3600.0	5.0
Decel Time 2	31	0.1 Sec	0.0	3600.0	5.0

efesotomasyon.com

Group/ Parameter	No.	Units	Min. Value	Max. Value	Default Value
Frequency Set - continued					
Presel Freq 1	27	0.1 Hz	0.0	400.0	10.0
Presel Freq 2	28	0.1 Hz	0.0	400.0	20.0
Presel Freq 3	29	0.1 Hz	0.0	400.0	30.0
Presel Freq 4	73	0.1 Hz	0.0	400.0	40.0
Presel Freq 5	74	0.1 Hz	0.0	400.0	50.0
Presel Freq 6	75	0.1 Hz	0.0	400.0	60.0
Presel Freq 7	76	0.1 Hz	0.0	400.0	0.0
Skip Freq 1	32	1 Hz	0	400	400
Skip Freq 2	33	1 Hz	0	400	400
Skip Freq 3	34	1 Hz	0	400	400
Skip Freq Band	35	1 Hz	0	15	0
MOP Increment	22	1 Hz/Sec	0.00	255.00	1.00
Analog Filter	144	Text ⊕	—	—	100%
Feature Select					
Run On Power Up	14	Text ⊕	—	—	Disabled
Reset/Run Tries	85	Numeric	0	9	0
Reset/Run Time	15	0.1 Sec	0.5	30.0	1.0
S Curve Enable	57	Text ⊕	—	—	Disabled
S Curve Time	56	0.1 Sec	0.0	300.0	0.0
Language	47	Text ⊕	—	—	Approp. Lang.
Cable Length	143	Text ⊕	—	—	Short
Rated Slip	146	0.1 Hz	0.0	5.0	2.0
Slip Comp Adder	148	0.01 Hz	0.00	5.00	—
IR Comp %	147	1%	0%	150%	Drv. Depend.
Output Configuration					
Output 1 Config	90	Text ⊕	—	—	Faulted
Output 2 Config	91	Text ⊕	—	—	Running
Analog Out Sel	25	Text ⊕	—	—	Frequency
Above Freq Val	77	1 Hz	0	400	0
Above Curr Val	142	1 %	0% of DRC	150% of DRC	0% of DRC
Faults					
Fault Buffer 0	86	Numeric	—	—	—
Fault Buffer 1	87	Numeric	—	—	—
Fault Buffer 2	88	Numeric	—	—	—
Fault Buffer 3	89	Numeric	—	—	—
Clear Fault	51	Text ⊕	—	—	Ready
Cur Lim Trip En	82	Text ⊕	—	—	Default Run
Line Loss Fault	40	Text ⊕	—	—	F03 Enable
Flt Clear Mode	39	Text ⊕	—	—	Enabled
Diagnostics					
Drive Command	58	Byte	—	—	—
Drive Status	59	Text ⊕	—	—	—
Drive Alarm	60	Byte	—	—	—
Input Status	55	Byte	—	—	—
Freq Source	62	Text ⊕	—	—	—
Freq Command	65	0.01 Hz	0.00	400.00	0.00
Drive Direction	69	Text ⊕	—	—	Forward
Motor Mode	43	Text ⊕	—	—	—
Power Mode	44	Text ⊕	—	—	—
Drive Type	61	Numeric	—	—	—
Firmware Ver.	71	Numeric	—	—	—
Output Pulses	67	1 Cycle	0	65535	—
Drive Temp	70	1 deg. C	0	100	—
Set Defaults	64	Text ⊕	—	—	Ready

Group/ Parameter	No.	Units	Min. Value	Max. Value	Default Value
Masks					
Logic Mask	92	Byte	—	—	01111111
Direction Mask	94	Byte	—	—	01111111
Start Mask	95	Byte	—	—	01111111
Jog Mask	96	Byte	—	—	01111111
Reference Mask	97	Byte	—	—	01111111
Accel Mask	98	Byte	—	—	01111111
Decel Mask	99	Byte	—	—	01111111
Fault Mask	100	Byte	—	—	01111111
MOP Mask	101	Byte	—	—	01111111
Local Mask	93	Byte	—	—	01111111
Owners					
Stop Owner	102	Byte	—	—	—
Direction Owner	103	Byte	—	—	—
Start Owner	104	Byte	—	—	—
Jog Owner	105	Byte	—	—	—
Reference Owner	106	Byte	—	—	—
Accel Owner	107	Byte	—	—	—
Decel Owner	108	Byte	—	—	—
Fault Owner	109	Byte	—	—	—
MOP Owner	110	Byte	—	—	—
Local Owner	137	Byte	—	—	—
Adapter I/O					
Data In A1	111	Numeric	0	149	0
Data In A2	112	Numeric	0	149	0
Data In B1	113	Numeric	0	149	0
Data In B2	114	Numeric	0	149	0
Data In C1	115	Numeric	0	149	0
Data In C2	116	Numeric	0	149	0
Data In D1	117	Numeric	0	149	0
Data In D2	118	Numeric	0	149	0
Data Out A1	119	Numeric	1	149	1
Data Out A2	120	Numeric	1	149	1
Data Out B1	121	Numeric	1	149	1
Data Out B2	122	Numeric	1	149	1
Data Out C1	123	Numeric	1	149	1
Data Out C2	124	Numeric	1	149	1
Data Out D1	125	Numeric	1	149	1
Data Out D2	126	Numeric	1	149	1
Process Display					
Process Par	127	Numeric	1	149	1
Process Scale	128	Numeric	-327.68	+327.67	+1.00
Process Text 1	129	ASCII txt	—	—	?
Process Text 2	130	ASCII txt	—	—	?
Process Text 3	131	ASCII txt	—	—	?
Process Text 4	132	ASCII txt	—	—	?
Process Text 5	133	ASCII txt	—	—	?
Process Text 6	134	ASCII txt	—	—	?
Process Text 7	135	ASCII txt	—	—	?
Process Text 8	136	ASCII txt	—	—	?

⊕ Refer to 1305-5.2 User Manual, Appendix B, Table B.5.

Power Terminal Block TB1 Designations

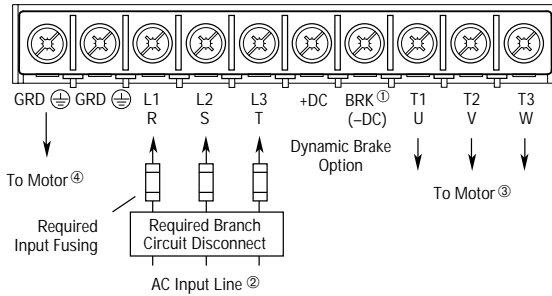

- Connection for Dynamic Brake Resistors for all models except the 200-230 Volt, 0.37 to 0.75 kW (0.5 to 1 HP) drive.
Important: The [DB Enable] parameter must be enabled for proper operation.
- For single phase applications, the AC input line can be connected to any two of the three input terminals R, S, T (L1, L2, L3).
- 1305 drives are UL listed and CSA certified as a motor overload protective device. An external overload relay is not required for single motor applications.
Important: This drive is not intended for use with single-phase motors.
- Ground from drive to motor frame must be an independent continuous insulated wire run.

TB1 Terminal Designations

Terminals	Description
GRD	Earth Ground
R, S, T (L1, L2, L3)	AC Input Line Terminals
+DC, BRK (or -DC)	Dynamic Brake Option – Refer to instructions included with option
U, V, W (T1, T2, T3)	Motor Connection

Input Fusing



ATTENTION: The drive does not provide branch circuit protection. Specifications for the recommended fuse size and type which provide branch circuit protection against short circuits are provided below. Branch circuit breakers or disconnect switches cannot provide this level of protection for drive components.

Maximum Recommended AC Input Line Fuse UL Class J, T, CC, or BS88 (or equivalent)

Three-Phase Rating kW (HP)	Single-Phase Rating kW (HP)	Fuse 200-230V Rating	Fuse 380-460V Rating
0.37 (0.5)	0.19 (0.25)	6	3 ①
0.55 (0.75)	0.37 (0.5)	6	3 ①
0.75 (1)	0.55 (0.75)	10	6 ②
1.5 (2)	0.75 (1)	15	10 ②
2.2 (3)	1.5 (2)	25	15 ②
4.0 (5)	-	-	20 ②

- Must be dual element time delay, Bussmann LPJ or equivalent.
- If fuse blowing is a problem, use dual element type fuses.

efesotomasyon.com

Terminal Block TB2 Designations

General Three Wire

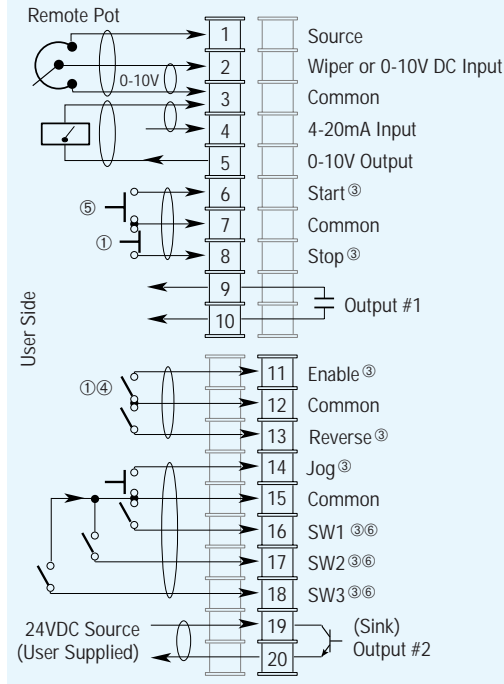

General Run Fwd/Rev

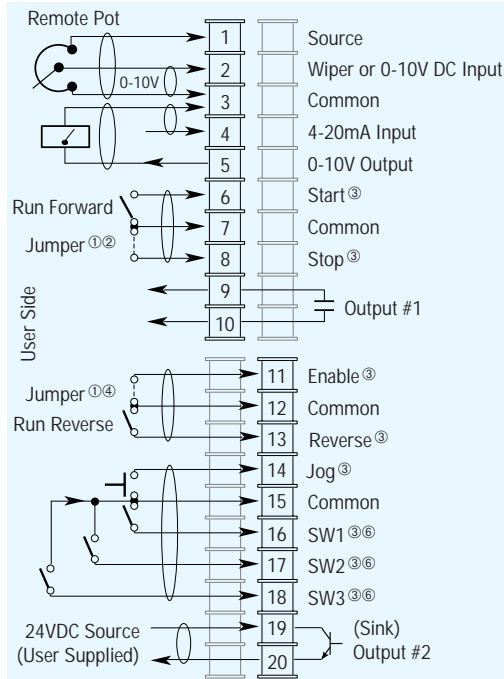

TB2 Terminal Descriptions

No.	Signal	Specification
1, 2, 3	External Speed Pot	10 kΩ Potentiometer, 2 Watts
2, 3	0-10V Analog Input	Drive Input Impedance = 100 kΩ
4, 3	4-20mA Analog Input	Drive Input Impedance = 250 Ω
5, 3	0-10V Analog Output	Meter Impedance ≥ 4 kΩ
6, 7	Start	Contact Closure Input ③
8, 7	Stop	Contact Closure Input ③
9, 10	Programmable Output 1	Resistive Rating=115V AC/30V DC, 5A Inductive Rating = 115 VAC/30 VDC, 2A
11, 12	Drive Enable	Contact Closure Input ③ ④
13, 12	Reverse	Contact Closure Input ③
14, 15	Jog	Contact Closure Input ③
16, 15	SW1	Contact Closure Input ③
17, 15	SW2	Contact Closure Input ③
18, 15	SW3	Contact Closure Input ③
19, 20	Programmable Output 2	24V DC ±20%, 50 mA Max. (Sink)

- Required to operate drive. STOP also used to clear a fault.
- Use HIM Stop button to clear faults.
- Contact Closure Input. Internal 5V supply. DO NOT apply external voltage.
- When the ENABLE signal is lost, the drive output immediately shuts off and the motor will coast to a stop.
- A Start command will override any Jog command.
- See 1305 User Manual (publication 1305-5.2) for input configurations based on the setting of parameter 21 - [Input Mode].

Faults

Diag C Lim Fault F36	The drive output current has exceeded the software [Current Limit] and the [Cur Lim Trip En] parameter was enabled.
Drive -> HIM	The checksum read from the HIM's EEPROM does not match the checksum calculated from the EEPROM data.
Drive Reset Fault F22	Occurs on power-up. Caused by having the START Input (or RUN Input) closed, with the STOP Input open and [Run On Power Up] = DISABLED.
EEPROM Fault F32	EEPROM has invalid data or can not be programmed to valid data.
Hz Err Fault F29	This fault indicates that there is not a valid operating frequency. It can be caused by: <ol style="list-style-type: none"> [Maximum Frequency] is less than [Minimum Freq]. Skip frequencies and skip bandwidth eliminate all operating frequencies. 4-20mA input signal speed reference has been lost or is out of range and [4-20mA Loss Sel] is set for "Stop-Fault."
Hz Sel Fault F30	An adapter that is not connected has been chosen as the active frequency source.
HIM -> Drive	Error 1 - The checksum read from the HIM's EEPROM does not match the checksum calculated from the EEPROM data. Error 2 - The number of parameters in saved profile does not equal master. Error 3 - Download was attempted to a different type drive (i.e. 1336 ->1305). Error 4 - Saved data for parameter not correct for new drive. Error 5 - Drive is running while attempting download.

IPM Current Fault F44	The internal power module overcurrent limit has been exceeded.
IPM Overtemp Fault F45	The internal power module thermal limit has been exceeded.
Max Retries Fault F33	Drive unsuccessfully attempted to reset a fault and resume running for the programmed number of [Reset/Run Tries] .
Motor Mode Flt F24	Internal error.
Motor Stall Fault F6	The motor is stalled.
Neg Slope Fault F35	Drive software detected a portion of the volts/Hz curve with a negative slope.
Network Error ✱	Error 0-6 SCANport Error Error 7-9 Communications Error
Op Error Fault F11	[Motor Type] is set to "Sync PM" and [Stop Mode] is set to "DC Brake".
Open Pot Fault F9	An external pot is connected and the ground lead of the pot is disconnected creating a potential drive overspeed hazard.
Overcurrent Fault F12	Overcurrent is detected in overcurrent hardware trip circuit.
Overload Fault F7	Internal electronic overload trip.
Overspeed Fault F25	Internal error.
Overtemp Fault F8	Temperature sensor detects excessive heat.
Overvolt Fault F5	DC bus voltage exceeded maximum value.
Phase U Fault F38	A phase to ground fault has been detected between the drive and motor in this phase.
Phase V Fault F39	A phase to ground fault has been detected between the drive and motor in this phase.
Phase W Fault F40	A phase to ground fault has been detected between the drive and motor in this phase.
Pin ID Error	Communication Hardware problem.
Power Loss Fault F3	DC bus voltage remained below 85% of nominal for longer than 0.500 sec. [Line Loss Fault] parameter is programmed to "F03 Enable".
Power Mode Fault F26	Internal error.
Power Test Fault F46	Fault detected during initial start-up sequence.
Reprogram Fault F48	Occurs when drive parameters are reset to defaults.
Run Boost Fault F34	An attempt has been made to set [Run Boost] to a value greater than [Start Boost] .
Serial Fault F10	An active local bus adapter is disconnected while it possesses control of a local bus function.
Undervolt Fault F4	DC Bus voltage fell below the minimum value. [Line Loss Fault] is programmed to "U Volt Run".
UV Short Fault F41	Excessive current has been detected between these two drive output terminals.
UW Short Fault F42	Excessive current has been detected between these two drive output terminals.
VW Short Fault F43	Excessive current has been detected between these two drive output terminals.

efesotomasyon.com

Human Interface Module

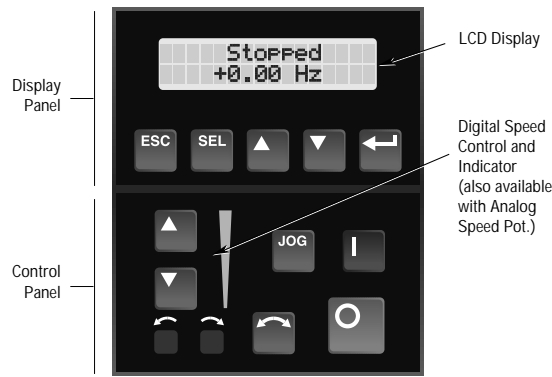

HIM Display Panel Descriptions

- ESC** **Escape**
When pressed, the ESCape key will cause the programming system to go back one level in the menu structure.
- SEL** **Select**
Pressing the SELect key alternately moves the cursor to the next active area. A flashing first character indicates which line is active.
- ▲ ▼** **Increment/Decrement**
These keys are used to increment and decrement a value or scroll through different groups or parameters.
- ↶** **Enter**
When pressed, a group or parameter will be selected or a parameter value will be entered into memory. After a parameter has been entered into memory, the top line of the display will automatically become active, allowing another parameter (or group) to be chosen.

HIM Control Panel Descriptions

- I** **Start**
The Start key will initiate drive operation if no other control devices are sending a Stop command. This key can be disabled by the **[Logic Mask]** or **[Start Mask]**.
- O** **Stop**
If the drive is running, pressing the Stop key will cause the drive to stop, using the selected stop mode. Refer to **[Stop Select]** in the User Manual.
If the drive has stopped due to a fault, pressing this key will clear the fault and reset the drive. Refer to **[Flt Clear Mode]**, **[Logic Mask]** and **[Fault Mask]**.
- JOG** **Jog**
When pressed, jog will be initiated at the frequency set by **[Jog Frequency]**, if no other control devices are sending a Stop command. Releasing the key will cause the drive to stop, using the selected stop mode. Refer to **[Stop Select]**, **[Logic Mask]** and **[Jog Mask]**.
Important: If the drive is running prior to issuing a jog command, the jog command will be ignored. A start command from another source will override the jog command.



Change Direction

Pressing this key will cause the drive to ramp down to zero Hertz and then ramp up to set speed in the opposite direction. The appropriate Direction LED will illuminate to indicate the direction of motor rotation. Refer to **[Logic Mask]** and **[Direction Mask]**. Note that the factory default for control of the reverse function is the reverse input at the TB2. To enable the HIM control of the reverse function, change "Bit 0" of the **[Direction Mask]** parameter to "0" to disable the reverse function at TB2.



Direction LEDs (Indicators)

These LEDs illuminate to indicate the direction of motor rotation.

		Rotating "Forward"
		Rotating "Reverse"
		Changing Direction, Decelerating "Reverse," will begin to Accelerate "Forward."
		Changing Direction, Decelerating "Forward," will begin to Accelerate "Reverse."



Increment Decrement Arrows

(only available with digital speed control)
Pressing these keys will increase or decrease the HIM frequency command. An indication of this command will be shown on the visual Speed Indicator LEDs. The drive will run at this command if the HIM is the selected frequency reference. See **[Freq Select 1/2]**.



Pressing both keys simultaneously stores the current HIM frequency command in HIM memory. The Speed Indicator LEDs will flash momentarily to indicate a successful save (if speed is above 20 percent). Cycling power or connecting the HIM to the drive will set the frequency command to the value stored in HIM memory.



Analog Speed Potentiometer

If the Analog Speed Potentiometer option has been ordered, the Increment/Decrement keys and Speed Indicator will be replaced by the pot.



Speed Indicator LEDs

(only available with digital speed control)
Illuminates in steps to give an approximate visual indication of the commanded speed.
If the Analog Speed Potentiometer option has been ordered, the Increment/Decrement keys and Speed Indicator LEDs will be replaced by the pot.