

Allen-Bradley

Bulletin 1305 AC Drives

**Simple,
Flexible, and
Performance-
Rich**



**Rockwell
Automation**

Bringing Together Leading Brands in Industrial Automation

Simple, Flexible and Performance-Rich



The Bulletin 1305 AC drive is a variable speed drive designed to control the speed of three-phase AC induction motors in a variety of demanding applications where flexibility, performance and ease of use are essential. The 1305 drive is available with ratings 0.37 to 4 kW (0.5 to 5HP) at 380-460V and 0.37 to 2.2 kW (0.5 to 3HP) at 200-230V.

Simple

Application performance requirements are often met "out of the box" without parameter adjustments. If parameter adjustments are necessary, these can be easily made using the Human Interface Module (HIM). This operator interface has large, positive feedback keys that allow for easy programming, but is small enough to carry in your pocket.

Flexible

The 1305 AC drive has a wide range of parameters which can be set to meet the requirements of many diverse applications. The standard SCANport™ communications link permits simple connections to a variety of communication peripherals including RS232/422/485, DeviceNet™, Remote I/O, and Flex™ I/O. The 1305 AC drive can connect to ControlNet™ and other networks via Allen-Bradley Flex I/O to SCANport communication module. With the addition of a SCANport expander, multiple devices can communicate with a 1305 AC drive.

Performance-Rich

High Torque

Simple does not imply reduced performance. The 1305 AC drive is capable of producing **high torque** across a wide speed range.

Fast Acceleration

Fast acceleration times mean more cycles per minute, and translates into increased revenue.



Performance Testing

The 1305 AC drive is tested on a dynamometer at Allen-Bradley's development facility.

Hybrid Current Limit

The **hybrid current limit** function utilizes both firmware and hardware control to minimize the possibility of trips during shock loads, fast accelerations, constant speed operation and deceleration.

IR Compensation

The **IR compensation** function increases power to the motor when it is needed most.

Slip Compensation

The 1305 AC drive features **Slip Compensation**, which provides tighter speed control during load changes.

Product Positioning

Offering the industry's broadest range of horsepower, functionality and features, Allen-Bradley has a drive which can help meet your requirements. From small stand-alone applications to massive, integrated systems, our full line of industrial drives provides the flexibility, reliability and precise motor control necessary to keep your business moving at the right speed. The 1305 drive has advanced technology in a rugged, compact package that offers the proper blend of performance and functionality to make it a market leader.

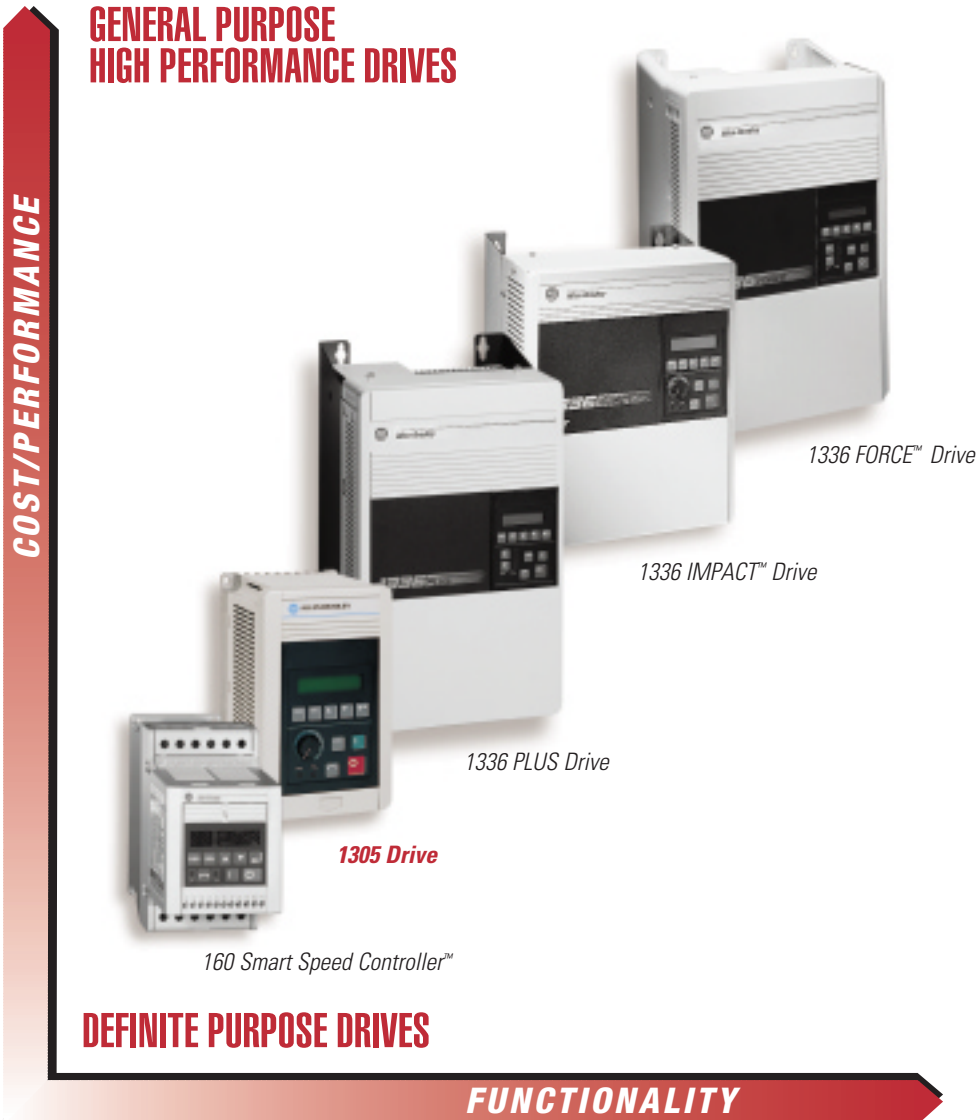

Human Interface Module (HIM)

The Human Interface Module (HIM) features a backlit LCD display and computer-like programming keys. Easy-to-read messages indicating drive status and diagnostic information allow the user to quickly react to changing process conditions. The HIM can be used with other SCANport products including 1336 FORCE™, 1336 IMPACT™ and 1336 PLUS drives.

Bridging the Gap

The performance and functionality of the Bulletin 1305 AC drive bridges the gap between Definite Purpose and General Purpose/High Performance drives.

Small, Yet Feature-Rich



Do not let the compact size fool you. Bulletin 1305 AC drives offer many features to enhance the performance of your application.

Design Features

Interface/Communications

- Human Interface Module with backlit LCD Display.
- Foreign language compatibility.
- Multiple communication options.

Software

- IR compensation.
- Inherent braking.
- Hybrid Current Limit.
- Slip compensation.
- Extensive parameter list.

Physical

- Intelligent power modules using IGBT technology.
- CE marked for all applicable European directives:
 - Emissions EN55011 Class B
 - Immunity EN50082-1
EN50082-2
- Standard IP30 (NEMA Type 1) enclosure.
- Optional Configured IP42 (NEMA Type 1) or IP65 (NEMA Type 4/12).
- Hinged front cover for easy access to the power and control wiring.
- Built-in protective features.

Control

- Configurable for either two-wire or three-wire control.
- 0 – 10V DC speed input.
- Remote potentiometer input.
- 4 – 20 mA analog speed input.
- Two programmable outputs (1 relay, 1 transistor).
- Programmable 0 – 10 volt analog output.

Hybrid Current Limit

The hybrid current limit function utilizes both firmware and hardware control to minimize the possibility of trips during shock loads, fast accelerations, constant speed operation and deceleration.

Inherent Braking

The inherent braking capability of the drive provides fast deceleration times by using a patented software-driven regulator to control the deceleration ramp. For many applications, this helps:

- Reduce the requirement for external braking resistors.
- Save valuable panel space.
- Lower installation costs.

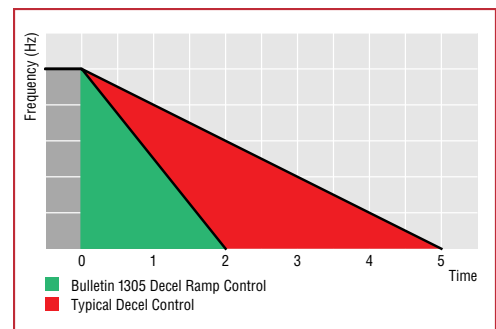

Built-in Protective Features

- Motor overload protection – UL listed and CSA certified as a motor overload protective device and designed to meet IEC and VDE standards for motor overload protection. *No external overload protection is required for single motor applications.* This saves valuable panel space and reduces the total installation cost.
- Short circuit on the output phases.
- Ground fault during power up of motor.
- Over temperature due to improper ventilation.

1305 AC Drive Performance: Real Test Data

Acceleration

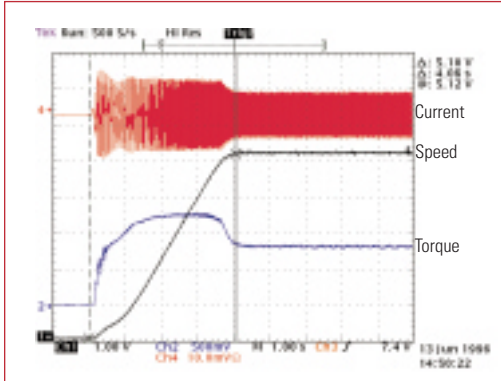

Accelerating @ 150% load, 0.1 sec. acceleration setting – note smooth motor speed response

- Fast acceleration.
- More cycles per hour.

Torque

Torque performance is exceptional (test progressively loads motor from at speed, no load condition to a stall)

- When machine cycle requires high torque at low speeds, the 1305 AC drive can deliver.
- Torque performance is maintained across the entire speed range.

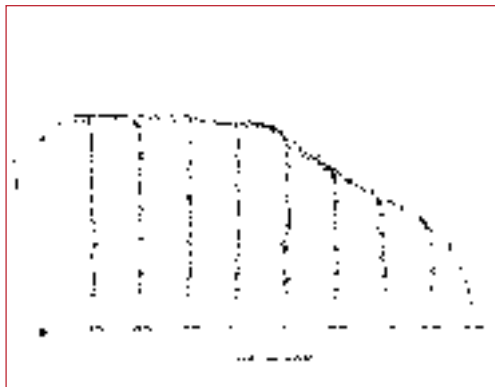

Shock Load

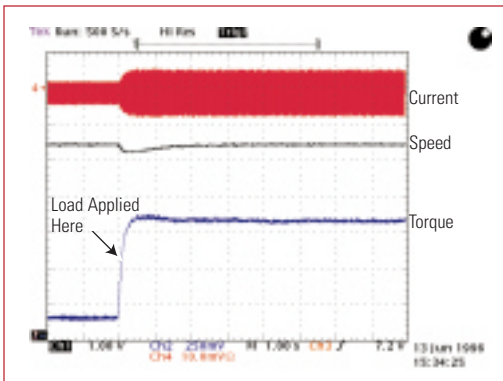

Dynamic response to shock load

- Even with shock loads demanding 150% torque, the 1305 AC drive maintains control of current and speed.

“Trip-Free” Operation

To help avoid nuisance tripping and improve process efficiency, the drive is designed with control logic that will:

- Regulate acceleration and deceleration ramp rates to help prevent overcurrent and overvoltage trips.
- Limit output current to 200% of drive output rating during intermittent overload conditions.

Quiet Operation

Bulletin 1305 AC drives use IGBT (insulated gate bi-polar transistor) technology to provide faster switching of the output transistors compared to conventional bi-polar transistors. The carrier frequency is adjustable in 100 Hz increments to help minimize audible noise and reduce mechanical resonance.

Integrated Automation

Drive Software for Windows™

DriveExplorer™ Software is an online programming tool that provides a fast, simple, cost-effective method to configure and monitor drive and communication adapter parameters. With an easy Windows "Explorer-like" interface, you have the ability to create custom parameter views by using the cut/copy/paste or drag & drop functionality. DriveExplorer is compatible with Microsoft Windows 95/98/NT/CE™.



DriveTools32™ Software suite for Microsoft® Windows 95/98/NT™ is designed for online and offline programming, troubleshooting, and maintaining Allen-Bradley AC and DC drive products. Easy-to-use menus, dialogs and graphic displays help you quickly start-up your Allen-Bradley drive product. Powerful diagnostic features simplify troubleshooting drives and drive systems.

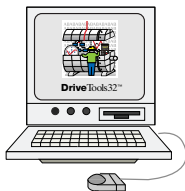

The Bulletin 1305 AC drive doesn't just provide connectivity to various communication networks and controllers but does much more. It becomes a key control strategy in an integrated automation system. The diagram below illustrates Allen-Bradley products and options that provide this high level of integration.

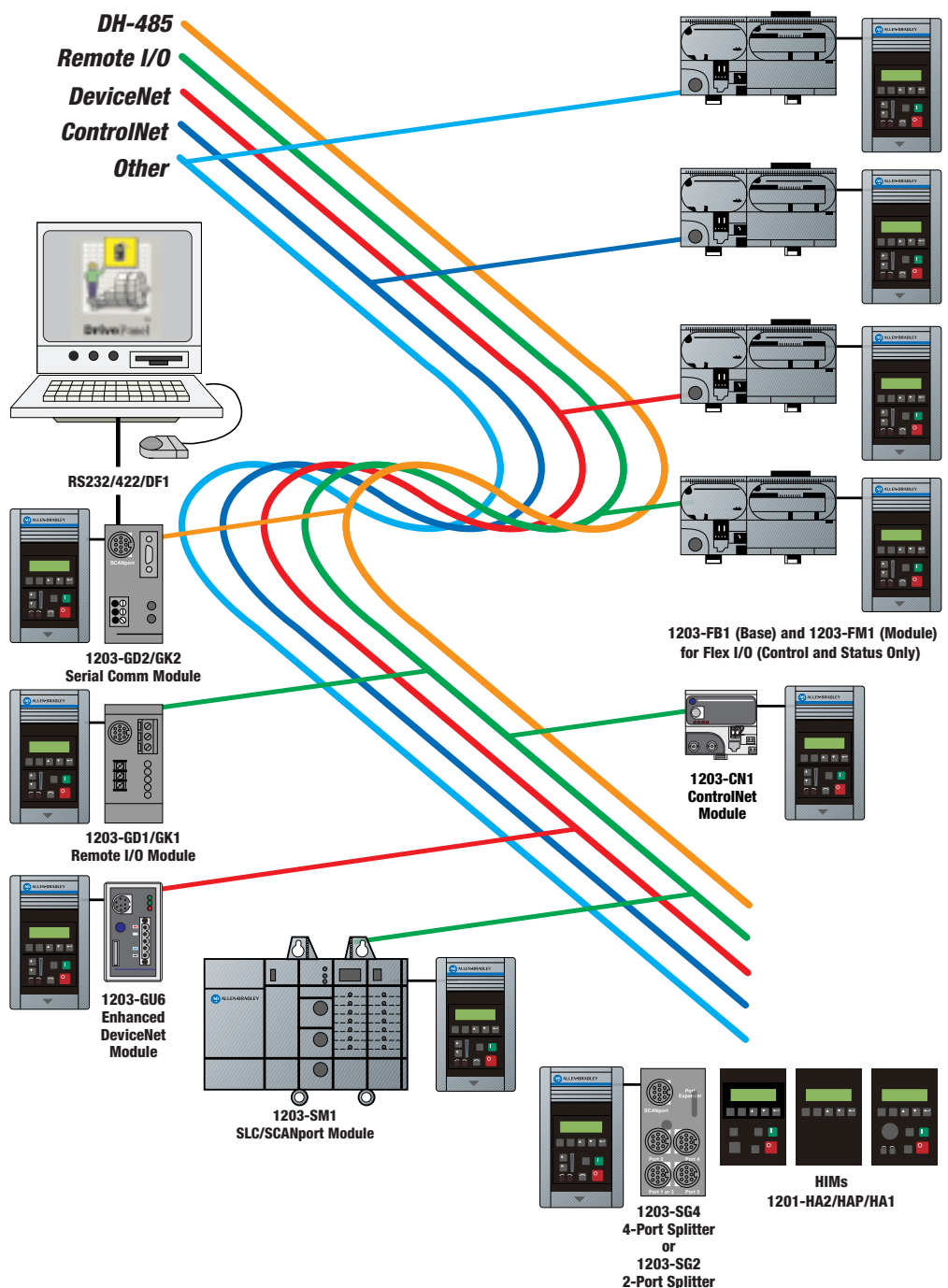

Operator Interface That Makes Sense



Customized Display for Your Process

The drive can display a process variable in "User Definable Units". A parameter, such as output frequency, can be converted and scaled to display process variables such as RPMs, liters per minute or gallons per hour. This descriptive display makes the drive easier to use and an integral part of the automation system.

Take Hold of the New Features Available with the Human Interface Module

Designed with simplicity in mind, the Human Interface Module (HIM) features a two-line, sixteen-character backlit LCD display and computer-like programming keys. Easy-to-read messages indicating drive status and diagnostic information allow the user to quickly react to changing process conditions. Available in IP30 (NEMA Type 1) and IP66 (NEMA Type 12/UL Type 4X – Indoor) designs.

Other features include:

- Upload/download capability: Resident memory allows for storage of two complete drive parameter profiles, saving time programming multiple drives.
- Search: Allows user to search a parameter profile to determine which features are no longer at factory default values.
- Immediate fault display: If a fault occurs, fault message appears regardless of what mode is in use.
- Bit Enumeration: User can scroll and view a text description of each bit in a binary parameter without using a look-up table for identification.
- Changing digits of parameters and passwords: Increment or decrement individual parameter digits to save programming time.
- Fault queue: View the last four faults in the Control Status mode without going into the Program or Display mode.
- Saving menus for power-up: Can be programmed to power up to a variety of process displays (i.e. RPM, Feet-per-minute, etc.).
- Commonality: The HIM can be used with other SCANport products including 1336 PLUS, 1336 IMPACT and 1336 FORCE AC drives.
- HIMs: Can be drive mounted, panel mounted or hand held with a cable connection.



HIM – Digital Speed Control

Provides digital speed control and programming functionality from the local panel.



HIM – Analog Speed Potentiometer

Provides analog speed control and programming functionality from the local panel.



HIM – Programmer Only

Provides programming functionality from the local panel.



HIM – NEMA 12/UL4X – Indoor

- HIMs are available in NEMA 12/UL4X – Indoor construction for remote panel mounting.
- Available as digital speed control and programmer only.

Configured to Meet Your Needs

Configured Drives Program

The Configured Drives Program allows you to order specifically configured drives packages that exceed the offerings of standard drive products. The expanded options list includes control, communications, power, packaging and documentation. Packaging is available in IP42 (NEMA Type 1) or IP65 (NEMA Type 4/12) enclosures.

The capabilities of this program range from supplying simple, commonly requested pre-engineered options to more complex, specifically engineered requirements.

All Allen-Bradley Configured Drives are supplied with complete, order-specific drawings and standard instruction manuals. Special documentation and test requirements will also be supplied as requested. Support publications are available to assist in custom configuration and ordering special drive packages.



Configured 1305 drive

Drives Are an Integral Part of CENTERLINE™ Motor Control Centers

Not only do we install thousands of drives in Motor Control Centers every year, but they've been in our Motor Control Centers for over a decade. In fact, one-third of all Allen-Bradley Motor Control Centers include drive units.



Bulletin 1305 drive units installed in an Allen-Bradley CENTERLINE Motor Control Center.

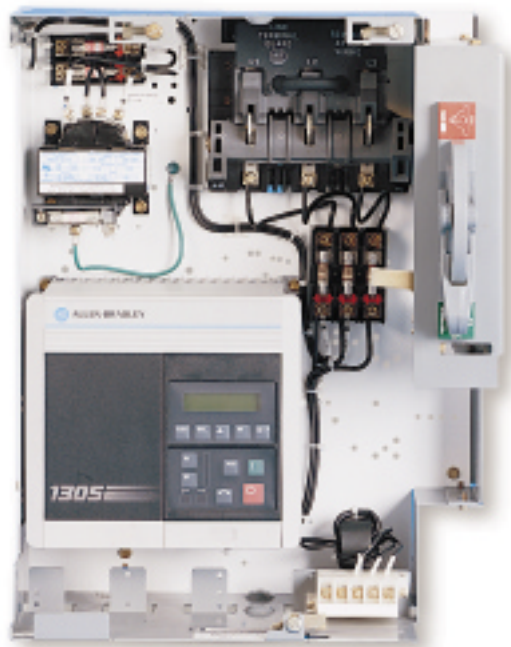

Motor Control Plug-In Unit with 5 HP Bulletin 1305 AC drive. MCC sections can have up to four 1305 drive units.

Use An Allen-Bradley Motor with 1305 AC Drives

Allen-Bradley motors provide improved operating efficiency. However, the complete answer goes further than this. Since the motor voltage waveshape is determined by both the drive and motor, optimum performance is achieved when the motor and drive are matched to each other. The Allen-Bradley Bulletin 1329R motor is matched in its electrical design to the 1305 drive. This improves performance and helps provide longer, cooler motor operation.

Not Every Motor is Optimized for Use on Adjustable Frequency Drives

Inverter rated motors available on the market today will operate satisfactorily with a 1305 drive. However, using an Allen-Bradley motor with your 1305 drive removes the guesswork and helps provide a complete solution from a single source you can trust.

OEM Needs Are Met with the 1305 AC Drive

- Proven product – time tested.
- Meets demands of cyclic loads.
- “Trip-free” operation.
- Programming commonality with other Allen-Bradley drives.
- HIM Upload/Download function for programming multiple drives.
- Communications – RS232, 422, 485, Remote I/O, DeviceNet, Flex I/O, Other.
- Feature-rich for flexibility.
- Slip Compensation.
- CE marked for all applicable European directives
 - Emissions EN55011 Class B
 - Immunity EN50082-1
EN50082-2
- Flexible firmware for special applications.

Note: The Configured Drives program shown on these pages is typical of North America. Other locations should contact their local Rockwell Automation office for availability of similar products.



Allen-Bradley Motors



Monorail Installation



Washing Machine Application

Applications

Transportation

- Monorails
- Material Handling
- Storage and Retrieval Systems
- Conveyors

Consumer

- Material Handling
- Conveyors
- Labeling
- Packaging
- Bottling
- Filling
- Screw Conveyor
- Pumps (Centrifugal and Positive Displacement)
- Mixers
- Ovens
- Pharmaceutical Process

Metals

- Lathe
- Vertical Milling Machine
- Small Lifts
- Mechanical Hoists
- Grinders

Petrochemical and Mining

- Mixers
- Pumps/Fans
- Grinders
- Injection Molding

Pulp and Paper

- Converting
- Mixing
- Flow Pumps

With the advancements in AC drives technology comes increased reliability and performance. The Bulletin 1305 AC drive is a proven solution for a multitude of applications including, but not limited to, those shown on this page.

Conveyors

Bulletin 1305 AC drives provide the performance demanded in high-speed conveyor applications.



Monorail

Monorails are used in installations where downtime can cost serious money. The 1305 AC drive's performance-rich design has gained the trust of industrial users.

Packaging

Varying load demands occurring with food processing equipment, such as packaging or bottling lines, are easily handled with the Bulletin 1305 AC drive.



Other Applications

The drive applications are endless. Bulletin 1305 AC drives offer smart solutions for many other applications, such as grinders.

Drive Product Selection

The Bulletin 1305 is a microprocessor controlled adjustable frequency drive designed for reliable control of three-phase induction motors. The drive produces a three-phase, PWM, adjustable frequency output to vary the motor speed. The drive output voltage is a function of output frequency and is adjustable to meet motor parameters so that optimum motor performance can be obtained.

For further information see:

Product Selection	Page 11
Accessories	Page 12
Specifications	Page 15
Dimensions	Page 17
Parameter List	Page 18
Configured Drives Program	Page 20

Bulletin 1305 Drives with Blank Front Panel (Cat. No. 1201-HAB) Installed as Standard

	Voltage Rating	Three-Phase Input			Single-Phase Input			IP30 (NEMA Type 1) Catalog Number ①②
		HP	kW	Output Current Rating	HP	kW	Output Current Rating	
 <p>AC Drive Cat. No. 1305-AA04A-HA1</p>	200-230V 50/60 Hz	0.5	0.37	2.3A	–	–	–	1305-AA02A
		0.75	0.55	3.0A	0.5	0.37	2.3A	1305-AA03A
		1	0.75	4.5A	0.75	0.55	3.0A	1305-AA04A
		2	1.5	8.0A	1	0.75	4.5A	1305-AA08A
		3	2.2	12.0A	2	1.5	8.0A	1305-AA12A
	380-460V 50/60 Hz	0.5	0.37	1.3A	–	–	–	1305-BA01A
		0.75	0.55	1.6A	–	–	–	1305-BA02A
		1	0.75	2.3A	–	–	–	1305-BA03A
		2	1.5	4.0A	–	–	–	1305-BA04A
		3	2.2	6.0A	–	–	–	1305-BA06A
		5	4.0	9.0A	–	–	–	1305-BA09A

- ① 1305 drives include English text display. A second language text display may be added, if required. To order a second language, add the appropriate letter code.



Language	Letter
German	DE
Spanish	ES
Italian	IT
French	FR

- ② To order a drive with a Human Interface Module (HIM) installed, add the appropriate suffix. **Note:** Blank panel is included as part of base Cat. No.

Human Interface Module (HIM)	Suffix
Analog Speed Potentiometer	-HA1
Digital Up-Down Speed Control	-HA2
Programmer Only	-HAP

Accessories



Bulletin 1201 Operator Interface Devices

	Description	Catalog Number			
		HIM (Human Interface Module)		GPT (Graphic Programming Terminal)	
 Human Interface Module  Graphic Programming Terminal	Programmer/Analog Speed Operator	IP30 (NEMA Type 1)	IP66 (NEMA Type 12) UL Type 4X Indoor	IP30 (NEMA Type 12)	Hand Held
	Programmer/Digital Speed Operator	1201-HA1	–	–	–
	Programmer Only	1201-HA2	1201-HJ2	1201-HJ3E	1201-HH3E
	Drive Blank Cover	1201-HAP	1201-HJP	1201-HJPE	1201-HHPE
	Door Mount Bezel Kit	1201-HAB	–	–	–
		1201-DMA	–	–	–



Bulletin 1202 Port Cables

	Length	Male-Male for Port 1 (Front)	Male-Female for Port 2 (Side)
		 Port Cable	0.33 Meter (1.1 Feet)
	1 Meter (3.3 Feet)	1202-C10	1202-H10
	3 Meter (9.8 Feet)	1202-C30	1202-H30
	9 Meter (29.5 Feet)	1202-C90	1202-H90

Bulletin 1203 Port Splitters

	Description	Catalog Number
		 2 Port Splitter Cable
 2 Port Splitter Module	2 Port Module	1203-SG2
	4 Port Module	1203-SG4

Bulletin 1203 Communication Modules

	Description	Required Power			Required Terminal Base
		24V DC	115V AC	None	
 Communication Module  Flex I/O Communication Module and Terminal Base	Remote I/O	1203-GK1	1203-GD1	–	–
	SLC (each connects up to 3 drives)	–	–	1203-SM1	–
	RS232/422/485 (DF1 & DH485 Protocols)	1203-GK2	1203-GD2	–	–
	DeviceNet	1203-GK5	–	–	–
	Enhanced DeviceNet	1203-GU6	–	–	–
	ControlNet	1203-CN1	–	–	–
	Flex I/O (each connects up to 2 drives)	–	–	1203-FM1	1203-FB1

Accessories

Bulletin 1203 Computer Interfaces

 <p>Smart Serial Converter with Serial Flash Cable</p>	Description	Use With . . .	Catalog Number
	Smart Serial Converter (includes SFC)	Drive	1203-SSS
	Serial Flash Cable	SLC Module Enhanced DeviceNet Module ControlNet Module	1203-SFC

1305 Dynamic Brake Kits

 <p>Dynamic Brake</p>	Description	Use With . . .	IP 30 (NEMA Type 1) Catalog Number
	When connected to a Bulletin 1305 drive, this kit helps provide additional AC Dynamic Braking Torque. (Not available for 1305-AA02, 1305-AA03, or 1305-AA04.)	1305-AA08	1305-KAA12
		1305-AA12	1305-KAA12
		1305-BA01	1305-KBA03
		1305-BA02	1305-KBA03
		1305-BA03	1305-KBA03
		1305-BA04	1305-KBA06
		1305-BA06	1305-KBA06
1305-BA09		1305-KBA09 ^①	

Bulletin 1321 Line Reactor

 <p>Line Reactor</p>	Description	Use With . . .	3% Impedance		5% Impedance	
			IP00 (Open Style)	IP10 (NEMA Type 1)	IP00 (Open Style)	IP10 (NEMA Type 1)
	Iron Core, 600V, Class H insulation, 115 degree C rise, copper wound, 50/60 Hz, terminal blocks, UL, CSA, CE.	1305-AA02	1321-3R4-B	1321-3RA4-B	1321-3R4-C	1321-3RA4-C
		1305-AA03	1321-3R4-A	1321-3RA4-A	1321-3R4-B	1321-3RA4-B
		1305-AA04	1321-3R4-A	1321-3RA4-A	1321-3R4-B	1321-3RA4-B
		1305-AA08	1321-3R8-A	1321-3RA8-A	1321-3R8-B	1321-3RA8-B
		1305-AA12	1321-3R12-A	1321-3RA12-A	1321-3R12-B	1321-3RA12-B
		1305-BA01	1321-3R2-B	1321-3RA2-B	1321-3R2-C	1321-3RA2-C
		1305-BA02	1321-3R2-A	1321-3RA2-A	1321-3R2-B	1321-3RA2-B
		1305-BA03	1321-3R2-A	1321-3RA2-A	1321-3R2-B	1321-3RA2-B
		1305-BA04	1321-3R4-B	1321-3RA4-B	1321-3R4-C	1321-3RA4-C
		1305-BA06 ^②	1321-3R4-B ^②	1321-3RA4-B ^②	1321-3R4-C ^②	1321-3RA4-C ^②
		1305-BA06	1321-3R8-B	1321-3RA8-B	1321-3R8-C	1321-3RA8-C
		1305-BA09 ^②	1321-3R8-B ^②	1321-3RA8-B ^②	1321-3R8-C ^②	1321-3RA8-C ^②
1305-BA09		1321-3R12-B	1321-3RA12-B	1321-3R12-C	1321-3RA12-C	

Bulletin 1204 Reflected Wave Reduction Device

 <p>Reflective Wave Reduction Devices</p>	Description	Use With . . .	IP 30 (NEMA Type 1)
	Connected between the drive and any standard motor to provide a simple solution to help protect motors from premature failure due to reflected wave impulses. 4kHz carrier frequency maximum. Mounts book style or stack style near the drive. The 1204-RWR2-09-C has the same footprint as the 1305-BA09A when stack style mounted. The 1204-RWR2-09-B has the same footprint as all the other 460V 1305 drives when stack style mounted.	All 460V 1305 Drives book style mounted, or 1305-BA01A, 1305-BA02A, 1305-BA03A, 1305-BA04A, 1305-BA06A stack style mounted	1204-RWR2-09-B
	1305-BA09A Drives stack style mounted only	1204-RWR2-09-C	

^① For use with Series C or B Drives Only. DO NOT use with Series A Drives.

^② Input reactor only.

Accessories



Bulletin 1204 Terminator

 <p>Motor Terminator</p>	Description	Use with . . .	IP30 (NEMA Type 1)
	<p>Connected to any standard motor to provide a simple solution in helping protect motors from premature failure due to reflected wave impulses. An integral connection cable is provided to simplify installation. Mounts near the motor. If you plan to operate your system at carrier frequency above 2kHz, consult the factory.</p>	1305-BA03A	1204-TFA1 ①
		1305-BA04A	1204-TFA1 or TFB2 ①
		1305-BA06A	1204-TFA1 or TFB2 ①
		1305-BA09A	1204-TFA1 ①

Bulletin 1321 Isolation Transformer

 <p>Isolation Transformer</p>	Description	Use with . . .	IP23 (NEMA Type 1)
	<p>230V/230V or 460V/460V, Delta primary/Wye secondary, Class H insulation, 150 degree rise, aluminum wound, 60 Hz, ±5% taps, (1) N.C. thermostat per coil, UL, CSA.</p>	1305-AA02	1321-3T005-AA
		1305-AA03	1321-3T005-AA
		1305-AA04	1321-3T005-AA
		1305-AA08	1321-3T005-AA
		1305-AA12	1321-3T005-AA
		1305-BA01	1321-3T005-BB
		1305-BA02	1321-3T005-BB
		1305-BA03	1321-3T005-BB
		1305-BA04	1321-3T005-BB
		1305-BA06	1321-3T005-BB
		1305-BA09	1321-3T007-BB

CE Conformance ②

 <p>Line Filter</p>	Filters	Use with . . .	Catalog Number
	<p>A EMC filter is required for CE Conformance. A Metal Conduit Plate (see below) is also required. ②</p>	1305-AA02	1305-RFB-5-A
		1305-AA03	1305-RFB-5-A
		1305-AA04	1305-RFB-5-A
		1305-AA08	1305-RFB-8-B
		1305-AA12	1305-RFB-12-C
		1305-BA01	1305-RFB-8-B
		1305-BA02	1305-RFB-8-B
		1305-BA03	1305-RFB-8-B
		1305-BA04	1305-RFB-8-B
		1305-BA06	1305-RFB-8-B
		1305-BA09	1305-RFB-12-C
		 <p>Metal Conduit Plate</p>	Metal Conduit Plates
<p>A Metal Conduit Plate is required for CE Conformance. May also be used for non-CE applications where a more rugged conduit termination is needed. ②</p>	1305-AA03		1305-MP-05-A
	1305-AA04		1305-MP-06-A
	1305-AA08		1305-MP-08-B
	1305-AA12		1305-MP-12-C
	1305-BA01		1305-MP-08-B
	1305-BA02		1305-MP-08-B
	1305-BA03		1305-MP-08-B
	1305-BA04		1305-MP-08-B
	1305-BA06		1305-MP-08-B
	1305-BA09		1305-MP-12-C

① See Bulletin 1204 Motor Terminator Brochure (publication 1204-1.0) for proper selection.

② Installation guidelines called out in Appendix D of the 1305 User's Manual (publication 1305-5.2) must be adhered to.

Specifications

	1305 Drives Rated 200-230V AC					1305 Drives Rated 380-460V AC					
	-AA02A	-AA03A	-AA04A	-AA08A	-AA12A	-BA01A	-BA02A	-BA03A	-BA04A	-BA06A	-BA09A
OUTPUT RATINGS											
Motor Rating kW (HP)	0.37 (0.5)	0.55 (0.75)	0.75 (1)	1.5 (2)	2.2 (3)	0.37 (0.5)	0.55 (0.75)	0.75 (1)	1.5 (2)	2.2 (3)	4.0 (5)
Output Current (A)	2.3	3.0	4.5	8.0	12.0	1.3	1.6	2.3	4.0	6.0	9.0
Output Voltage	Adjustable from 0 Volts to input voltage										
Output Frequency (Hz)	0.00 to 400.00 Hz programmable										
INPUT RATINGS											
Input Voltage & Frequency	200/230V Three-Phase, 50/60 Hz					380/460V Three-Phase, 50/60 Hz					
Operational Range (V)	180-265V					340-500V					
Input kVA	0.9	1.3	1.7	3.1	4.6	0.9	1.3	1.7	3.1	4.6	7.0
Power Factor (Displacement)	0.8 (Lagging)										
Efficiency (%)	97.5% (Typical)										
Power Dissipation (W)	27	34	46	76	108	21	27	34	52	73	107
ENVIRONMENTAL SPECIFICATIONS											
Enclosure	IP30 (NEMA 1) standard										
Ambient Temperature	0 to 50 degrees C; optional enclosures: 0 to 40 degrees C.										
Storage Temperature	-40 to 70 degrees C										
Relative Humidity	0 to 95% (non condensing)										
Vibration	1.0 G Operational										
Cooling Method	Natural Convection (no fans)										
Altitude	Above 1,000 meters (3,300 feet), derate at 6% of drive rated amps per 1000 meters (3,300 feet).										
CONTROL INPUTS											
Control Input Type	Contact closure (internal 5V supply). DO NOT ground or apply external voltage.										
Start	Configurable inputs for 2 or 3 wire control										
Stop											
Forward/Reverse											
Jog	Momentary (non-maintained) input										
SW1	Configurable inputs for control of 7 preset speeds and 2 accel/decel times										
SW2											
SW3											
Enable	Interlock input to enable drive operation										
External Speed Potentiometer	10k Ohms, 1 Watt										
Analog Input (4 to 20mA)	Input Impedance 250 Ohms (non-isolated), 10 bit resolution										
Analog Input (0 to 10 V)	Input impedance 100 k Ohms (non-isolated), 10 bit resolution										
CONTROL OUTPUTS											
Programmable Output 1	Form A Relay Contact: Resistive Rating 115V AC/ 30V DC, 5A; Inductive Rating 115V AC/ 30V DC, 2A										
Programmable Output 2	Open Collector (Sink): 24V DC, ±20%, 50 mA maximum. User supplied source voltage.										
Analog Output (0-10V DC)	Load Impedance greater than or equal to 4,000 Ohms, 8 bit resolution										
PWM Algorithm	Sine weighted PWM output										
Switching Device	IGBT Intelligent Power Module										
Three-Phase Output	Programmable										
V/Hz Ratio											
Carrier Frequency											
DC Boost	Adjustable single point or full custom - start and run boost available.										

Specifications

	1305 Drives Rated 200-240V AC					1305 Drives Rated 380-460V AC					
	-AA02A	-AA03A	-AA04A	-AA08A	-AA12A	-BA01A	-BA02A	-BA03A	-BA04A	-BA06A	-BA09A
CONTROL FEATURES											
AC Dynamic Braking Torque ^①											
W/o External Resistor	100%	100%	100%	50%	50%	100%	100%	100%	50%	50%	20%
With External Resistor	N/A	N/A	N/A	150%	100%	150%	150%	150%	150%	100%	100%
Current Limiting	Trip Free Operation, coordinated for drive and motor protection Programmable from 20% to 150% of Drive Rated Current										
Overload	200%, Fixed by hardware, based on Drive Rating. 150% for 60 seconds.										
Motor Protection	Electronic Overload Protection. adjustable from 20% to 115% (Motor FLA)										
Overload Pattern #0	Flat response over speed range (no speed compensation)										
Overload Pattern #1	Speed compensation below 25% of Base Speed										
Overload Pattern #2	Speed compensation below 50% of Base Speed										
Accel/Decel Time(s)	0.1 to 3600 seconds, independently set (2 Accel, 2 Decel)										
Preset Speeds	0 to 400 Hz, 7 selections, independently set										
Jog Input	0 to 400 Hz										
Stopping Modes	4 modes programmable										
Ramp to stop	0.1 to 3600 seconds										
Coast	Stops all PWM Output										
DC Brake to stop	Applies DC Voltage to the motor for 0 to 150 seconds										
S-Curve	Ramps to stop with S-Curve profile										
PROTECTIVE FEATURES											
Excessive Temperature	Embedded temperature sensor trips if factory preset level is exceeded.										
Over/Under Voltage	DC Bus voltage is monitored										
Power Ride Through	Minimum ride through 15ms under nominal conditions										
Control Ride Through	Minimum ride through is 0.5 seconds - typical value 2 seconds										
Ground Short	Any output short to ground, detected prior to start										
Line Voltage Transients	Inherent MOV (varistor) protection										
Output Short Circuit	Inherent short circuit protection provided within IPM										
PROGRAMMING/COMMUNICATIONS											
Hand Held Programming	Optional Human Interface Module (HIM can be removed from the Drive)										
Type of Annunciation	Parameters displayed in textual form, organized in logical groupings										
Type of Display	16 character, 2 line LCD supertwist with backlight										
Language Capability	Multiple languages available										
Local Controls	3 versions available (digital pot., analog pot. and blank)										
Communication Adapters	Optional adapters provide Remote I/O, or RS232/422/485/DH485 or RS232/422/485/DF1 capability										
MONITORING											
Output Frequency (Hz)	Displayed over the entire range of operation with direction indication										
Output Voltage (V)	Selectable as a displayed parameter										
Output Current (A)	Selectable as a displayed parameter in % or actual value										
Output Power (kW)	Selectable as a displayed parameter in % or actual value										
DC Bus Voltage (V)	Selectable as a displayed parameter										
Frequency Command (Hz)	Selectable as a displayed parameter										
Process Parameter	Any drive variable can be scaled and definable text can be added up to 8 characters										
Drive Temperature	Selectable as a displayed parameter in degrees C.										
Last Fault	The previous 4 faults can be displayed for troubleshooting										

① Estimated – actual value will depend on motor characteristics.

Specifications

Bulletin 1305 Drive Dimensions

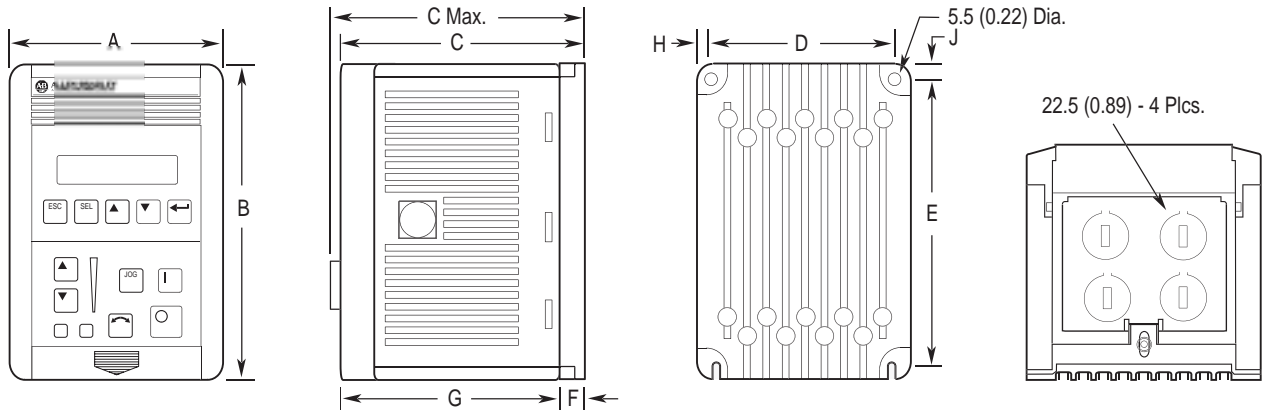

Dimensions are in millimeters (inches) and are not intended for manufacturing purposes. Shipping weights are in kilograms (pounds).

200/230 V Cat. No. 1305- ...	380/460 V Cat. No. 1305- ...	A Width	B Height	C Depth w/o Pot.	C Max. Depth w/ Pot.	D	E	F	G	H	J	Approx. Ship Wt.
AA02A	-	120 (4.72)	195 (7.68)	122 (4.80)	127.1 (5.00)	110 (4.33)	180 (7.09)	9 (0.35)	113 (4.45)	5 (0.20)	7.5 (0.30)	1.6 (3.5)
AA03A	-	120 (4.72)	195 (7.68)	140 (5.51)	145.1 (5.71)	110 (4.33)	180 (7.09)	27 (1.06)	113 (4.45)	5 (0.20)	7.5 (0.30)	1.9 (4.2)
AA04A	-	120 (4.72)	195 (7.68)	140 (5.51)	145.1 (5.71)	110 (4.33)	180 (7.09)	27 (1.06)	113 (4.45)	5 (0.20)	7.5 (0.30)	1.9 (4.2)
AA08A	BA01A BA02A BA03A BA04A BA06A	170 (6.69)	195 (7.68)	179 (7.05)	184.1 (7.25)	160 (6.30)	180 (7.09)	66 (2.60)	113 (4.45)	5 (0.20)	7.5 (0.30)	3.6 (8.0)
AA12A	BA09A	210 (8.27)	195 (7.68)	179 (7.05)	184.1 (7.25)	200 (7.87)	180 (7.09)	66 (2.60)	113 (4.45)	5 (0.20)	7.5 (0.30)	4.2 (9.2)

Bezel Kit (Catalog Number 1201-DMA)

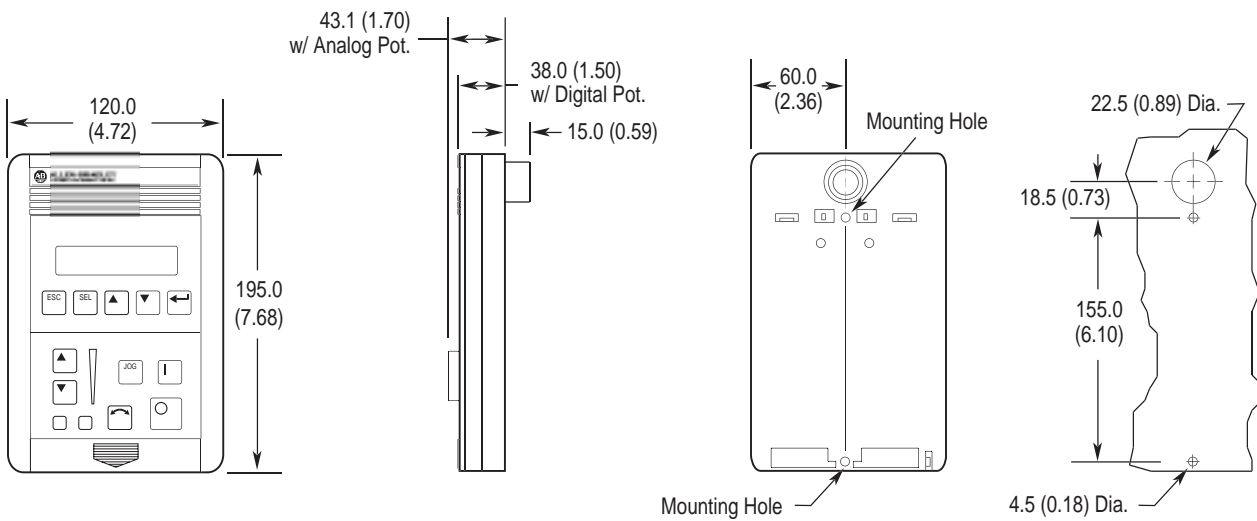

1305 Parameter List

Parameter Group	Parameter Name	No.	Units	Minimum	Maximum	Factory Setting
Metering	Output Current	54	0.01 Amps	0.00	Two times drive output current	--
	Output Voltage	1	1 Volt	0	Maximum Voltage	--
	Output Power	23	0.01 kW	0.00	Two times rated drive output power	--
	DC Bus Voltage	53	1 Volt	0	410 - 230V Drive 815 - 460V Drive	--
	Output Freq	66	0.01 Hz	0.00	Maximum Frequency	--
	Freq Command	65	0.01 Hz	0.00	+400.00	0.00
	MOP Hertz	42	0.01 Hz	0.00	400.00	--
	Drive Temp	70	1 degree C.	0	100	--
	Last Fault	4	Numeric	0	Max. Fault Number	--
	% Output Power	3	1%	0	200% Drive Rated Power	--
% Output Curr	2	1%	0	200% of Rated Drive Output Current	--	
Set Up	Input Mode	21	Text	--	--	Three Wire
	Freq Select 1	5	Text	--	--	Adapter 1
	Accel Time 1	7	0.1 Seconds	0.0	3600.0	10.0
	Decel Time 1	8	0.1 Seconds	0.0	3600.0	10.0
	Base Frequency	17	1 Hz	40	400	60
	Base Voltage	18	1 Volt	25% of DRV	100% of Max. Drive Rated Volts	100% of Max. DRV
	Maximum Voltage	20	1 Volt	25% of DRV	110% of Max. Drive Rated Volts	100% of Max. DRV
	Minimum Freq	16	1 Hz	0	120	0
	Maximum Freq	19	1 Hz	40	400	60
	Stop Select	10	Text	--	--	Ramp
	Current Limit	36	1%	20% of DRC	150% of Drive Rated Current (DRC)	150% of DRC
	Overload Mode	37	Text	--	--	No Derating
	Overload Current	38	0.1 Amps	20% of DRC	115% of Drive Rated Current (DRC)	115% of DRC
	Sec Curr Limit	141	1%	0	150% of Drive Rated Current (DRC)	0
Adaptive I Lim	149	Text	--	--	Enabled	
Advanced Setup	Minimum Freq	16	1 Hz	0	120	0
	Maximum Freq	19	1 Hz	40	400	60
	Base Frequency	17	1 Hz	40	400	60
	Base Voltage	18	1 Volt	25% of DRV	100% of Max. Drive Rated Volts	100% of Max. DRV
	Break Frequency	49	1 Hz	0	120	30
	Break Voltage	50	1 Volt	0	50% of Maxi. Drive Rated Volts	Drive Size Depend.
	Maximum Voltage	20	1 Volt	25% of DRV	110% of Max. Drive Rated Volts	100% of Max. DRV
	DC Boost Select	9	Text	--	--	Break Point
	Start Boost	48	1 Volt	0	25% of Max. Drive Rated Volts	Drive Size Depend.
	Run Boost	83	1 Volt	0	25% of Max. Drive Rated Volts	0
	PWM Frequency	45	0.1 kHz	2.0	8.0	4.0
	Analog Invert	84	Text	--	--	Disabled
	4-20 mA Loss Sel	81	Text	--	--	Stop/Fault
	Stop Select	10	Text	--	--	Ramp
	DC Hold Time	12	0.1 Seconds	0.0	150.0	0.0
	DC Hold Volts	13	1 Volt	0	25% of Maximum Drive Rated Volts	0
	DB Enable	11	Text	--	--	Disabled
	Motor Type	41	Text	--	--	Induc/Reluc
	Compensation	52	Text	--	--	Comp.
	Frequency Set	Freq Select 1	5	Text	--	--
Freq Select 2		6	Text	--	--	Remote Pot
Jog Frequency		24	0.1 Hz	0	400.0	10.0
Prst/2nd Accel		26	Text	--	--	Preset
Upper Presets		72	Text	--	--	Disabled
Accel Time 2		30	0.1 Seconds	0.0	3600.0	5.0
Decel Time 2		31	0.1 Seconds	0.0	3600.0	5.0
Preset Freq 1		27	0.1 Hz	0.0	400.0	10.0
Preset Freq 2		28	0.1 Hz	0.0	400.0	20.0
Preset Freq 3		29	0.1 Hz	0.0	400.0	30.0
Preset Freq 4		73	0.1 Hz	0.0	400.0	40.0
Preset Freq 5		74	0.1 Hz	0.0	400.0	50.0
Preset Freq 6		75	0.1 Hz	0.0	400.0	60.0
Preset Freq 7		76	0.1 Hz	0.0	400.0	0.0
Skip Freq 1		32	1 Hz	0	400	400
Skip Freq 2		33	1 Hz	0	400	400
Skip Freq 3		34	1Hz	0	400	400
Skip Freq Band		35	1 Hz	0	15	0
MOP Increment		22	1 Hz/Second	0.00	255.00	1.00
Analog Filter		144	Text	--	--	100%

1305 Parameter List

Parameter Group	Parameter Name	No.	Units	Minimum	Maximum	Factory Setting
Feature Select	Run On Power Up	14	Text	--	--	Disabled
	Reset/Run Tries	85	Numeric	0	9	0
	Reset/Run Time	15	0.1 Seconds	0.5	30.0	1.0
	S Curve Enable	57	Text	--	---	Disabled
	S Curve Time	56	0.1 Seconds	0.0	300.0	0.0
	Language	47	Text	--	--	Appropriate Lang.
	Cable Length	143	Text	--	--	Short
	Rated Slip	146	0.1 Hz	0.0	5.0	2.0
Output Config	Slip Comp Adder	148	0.01 Hz	0.00	5.00	--
	IR Comp %	147	1%	0%	150%	Drive Size Depend.
	Output 1 Config	90	Text	--	--	Faulted
	Output 2 Config	91	Text	--	--	Running
	Analog Out Sel	25	Text	--	--	Frequency
	Above Freq Val	77	1 Hz	0	400	0
	Above Curr Val	142	1%	0% of DRC	150% of Drive Rated Current	0% of DRC
	Faults	Fault Buffer 0-3	86-89	Numeric	--	--
Clear Fault		51	Text	--	--	Ready
Cur Lim Trip En		82	Text	--	--	Default Run
Line Loss Fault		40	Text	--	--	F03 Enable
Flt Clear Mode		39	Text	--	--	Enabled
Diagnostics	Drive Command	58	Byte	--	--	--
	Drive Status	59	Word	--	--	--
	Drive Alarm	60	Byte	--	--	--
	Input Status	55	Byte	--	--	--
	Freq Source	62	Text	--	--	--
	Freq Command	65	0.01 Hz	0.00	400.00	0.00
	Drive Direction	69	Text	--	--	Forward
	Motor Mode	43	Text	--	--	--
	Power Mode	44	Text	--	--	--
	Drive Type	61	Numeric	--	--	--
	Firmware Ver	71	Numeric	--	--	--
	Output Pulses	67	1 Cycle	0	65535	--
	Drive Temp	70	1 degree C.	0	100	--
Masks	Set Defaults	64	Text	--	--	Ready
	Logic Mask	92	Byte	--	--	01111111
	Direction Mask	94	Byte	--	--	01111111
	Start Mask	95	Byte	--	--	01111111
	Jog Mask	96	Byte	--	--	01111111
	Reference Mask	97	Byte	--	--	01111111
	Accel Mask	98	Byte	--	--	01111111
	Decel Mask	99	Byte	--	--	01111111
	Fault Mask	100	Byte	--	--	01111111
Owners	MOP Mask	101	Byte	--	--	01111111
	Local Mask	93	Byte	--	--	01111111
	Stop Owner	102	Byte	--	--	--
	Direction Owner	103	Byte	--	--	--
	Start Owner	104	Byte	--	--	--
	Jog Owner	105	Byte	--	--	--
	Reference Owner	106	Byte	--	--	--
	Accel Owner	107	Byte	--	--	--
Adapter I/O	Decel Owner	108	Byte	--	--	--
	Fault Owner	109	Byte	--	--	--
	MOP Owner	110	Byte	--	--	--
	Local Owner	137	Byte	--	--	--
	Data In A1, A2	111, 112	Numeric	0	149	0
	Data In B1, B2	113, 114	Numeric	0	149	0
	Data In C1, C2	115, 116	Numeric	0	149	0
	Data In D1, D2	117, 118	Numeric	0	149	0
Data Out A1, A2	119, 120	Numeric	1	149	1	
Data Out B1, B2	121, 122	Numeric	1	149	1	
Data Out C1, C2	123, 124	Numeric	1	149	1	
Data Out D1, D2	125, 126	Numeric	1	149	1	
Process Display	Process Par	127	Numeric	1	149	1
	Process Scale	128	Numeric	-327.68	+327.67	1.00
	Process Text 1-8	129-136	ASCII Text	--	--	?

Configured Drives Program

1305 Configured Catalog Number Explanation

1305 – **AA02AC** – **HA1C** – **GD1C** – **CB**

Bulletin Number

Rating-Enclosure
(must be specified)

Human Interface
(optional) ①

Communication Card
(optional) ①

Remaining Options
(as/if required) ①

Configured Product Selection

Constant or Variable Torque Drive, English/English Language Module and enclosure.

Drive Rating		Drive Amps	Bypass Amps ^⑥	IP42 (NEMA Type 1) General Purpose	IP65 (NEMA Type 4/12 ^②) Resist Water, Dust
Input Voltage	Nominal kW (HP)				
208V AC	0.37 (0.5)	2.3	2.3	HA02AC	HA02FC
	0.55 (0.75)	3.0	3.0	HA03AC	HA03FC
	0.75 (1)	4.5	4.2	HA04AC	HA04FC
	1.5 (2)	8.0	8.0	HA08AC	HA08FC
	2.2 (3)	12.0	10.0	HA12AC	HA12FC
230V AC	0.37 (0.5)	2.3	2.3	AA02AC	AA02FC
	0.55 (0.75)	3.0	3.0	AA03AC	AA03FC
	0.75 (1)	4.5	4.2	AA04AC	AA04FC
	1.5 (2)	8.0	8.0	AA08AC	AA08FC
	2.2 (3)	12.0	10.0	AA12AC ^③	AA12FC ^③
380V AC	0.37 (0.5)	1.3	1.0	NA01AC	NA01FC
	0.55 (0.75)	1.6	1.6	NA02AC	NA02FC
	0.75 (1)	2.3	2.3	NA03AC	NA03FC
	1.5 (2)	4.0	4.0	NA04AC	NA04FC
	2.2 (3)	6.0	6.0	NA06AC	NA06FC
	4.0 (5)	9.0	9.0	NA09AC	NA09FC
480V AC	0.37 (0.5)	1.3	1.0	BA01AC	BA01FC
	0.55 (0.75)	1.6	1.6	BA02AC	BA02FC
	0.75 (1)	2.3	2.3	BA03AC	BA03FC
	1.5 (2)	4.0	4.0	BA04AC	BA04FC
	2.2 (3)	6.0	6.0	BA06AC ^④	BA06FC ^④
	4.0 (5)	9.0	9.0	BA09AC ^⑤	BA09FC ^⑤

- ① As many valid options as required may be strung together with a dash between each option code number.
- ② If a Door Mounted Human Interface Module is supplied, the enclosure will no longer meet NEMA Type 4, but it will meet IP65 qualifications for watertight indoor applications.
- ③ When operating the drive in an ambient temperature at or near the maximum operating temperature (40 degrees C.), the following derating guidelines are recommended to guard against overheating (depending on application and operating conditions): At 230V input voltage, output current is 9.6A for three-phase and 6.8A for single-phase.
- ④ When operating the drive in an ambient temperature at or near the maximum operating temperature (40 degrees C.), the following derating guidelines are recommended to guard against overheating (depending on application and operating conditions): At 415V input voltage, output current is 5.3A. At 460V input voltage, output current is 4.8A.
- ⑤ When operating the drive in an ambient temperature at or near the maximum operating temperature (40 degrees C.), the following derating guidelines are recommended to guard against overheating (depending on application and operating conditions): At 415V input voltage, output current is 8.4A. At 460V input voltage, output current is 7.6A.
- ⑥ When Bypass is ordered, the drive system is rated to the lower of the drive rating or thermal overload relay rating (as noted by Bypass Amps).

Configured Drives Program

Factory Installed Options

Language Modules

Description	Option Code	Can Not be Used With . . .
English/English	Standard	
English/German	-DEC①	ESC, FRC, ITC
English/Spanish	-ESC①	DEC, FRC, ITC
English/Italian	-ITC①	DEC, ESC, FRC
English/French	-FRC①	DEC, ESC, ITC

Power Disconnecting Means

Description	Option Code	Can Not be Used With . . .
Circuit Breaker	-CB	DS
Fused Disconnect Switch (Class J)	-DS	CB

Drive Bypass Operation

Description	Option Code	Can Not be Used With . . .
Bypass, Manual	-BM②	–

Control Power

Description	Option Code	Can Not be Used With . . .
Control Power Transformer, 50VA	-CP	–

Human Interface Modules, Door Mounted

Description	Option Code	Can Not be Used With . . .
IP 42 (NEMA Type 1) Bezel Mount Programmer Only	-HAPC	HA1C, HA2C, HJPC, HJ2C, IP 65 or NEMA Type 4/12 Enclosures D13, D17, D19, D32, D61, HA2C, HAPC, HJ2C, HJPC, IP65 or NEMA Type 4/12 Enclosures
Programmer/Control with Analog Potentiometer	-HA1C	
Programmer/Control with Digital Potentiometer	-HA2C	
IP 65 (NEMA Type 12) Programmer Only	-HJPC	HAPC, HA1C, HA2C, HJ2C, NEMA Type 1 or 4 Enclosures D13, D17, D19, D32, D61, HA1C, HA2C, HAPC, HJPC, NEMA Type 1 or 4 Enclosures
Programmer/Control with Digital Potentiometer	-HJ2C	
IP 65 (NEMA Type 4)	Not Available	

Communication and Control Interface Modules

Description	Option Code	Can Not be Used With . . .
Single Point Remote I/O	-GD1C②	GD2C
RS232/422/485, DF1 and DH485 Protocol	-GD2C②	GD1C
24V DC Interface Card with Relay	-LTR24⑤	LTR120
120V AC Interface Card with Relay	-LTR120⑤	LTR24

Operator Devices, Door Mounted

Description	Option Code	Can Not be Used With . . .
Hand/Off/Auto (Start/Stop/Speed) Selector Switch	-D13③④	D17, D19, HA1C, HA2C, HJ2C
Start and Stop Pushbuttons	-D17③④	D13, D19, HA1C, HA2C, HJ2C
Start, Stop and Jog Pushbuttons	-D19③④	D13, D17, HA1C, HA2C, HJ2C
Forward/Reverse Selector Switch	-D32④	HA1C, HA2C, HJ2C
Speed Potentiometer, 1-Turn	-D61④	HA1C, HA2C, HJ2C
Drive/Off/Bypass Selector Switch	Std. w/Option BM	

Configured Drives Program

Pilot Lights, Door Mounted - Choose Only One

Description	Option Code	Can Not be Used With . . .
Drive Run (White)	-D35 ②	D31, D36, D37, D38, D39
Drive Fault (Red)	-D36 ②	D31, D35, D37, D38, D39
At Speed (Amber)	-D31 ②	D35, D36, D37, D38, D39
Alarm (Red)	-D37 ②	D31, D35, D36, D38, D39
Above Current (Amber)	-D38 ②	D31, D35, D36, D37, D39
Above Frequency (Amber)	-D39 ②	D31, D35, D36, D37, D38

- ① Replaces the Standard English/English Language Module supplied with the basic drive.
- ② Option -CP or user supplied 115V AC control power is required.
- ③ Only one (-D13, -D17 or -D19) option may be specified.
- ④ Can not be used with options -HA1C, -HA2C or -HJ2C.
- ⑤ Configurations which include this option are not C-UL approved at this time.

Enclosure Dimensions

IP42 (NEMA Type 1) and IP65 (NEMA Type 4/12) Enclosed Drives

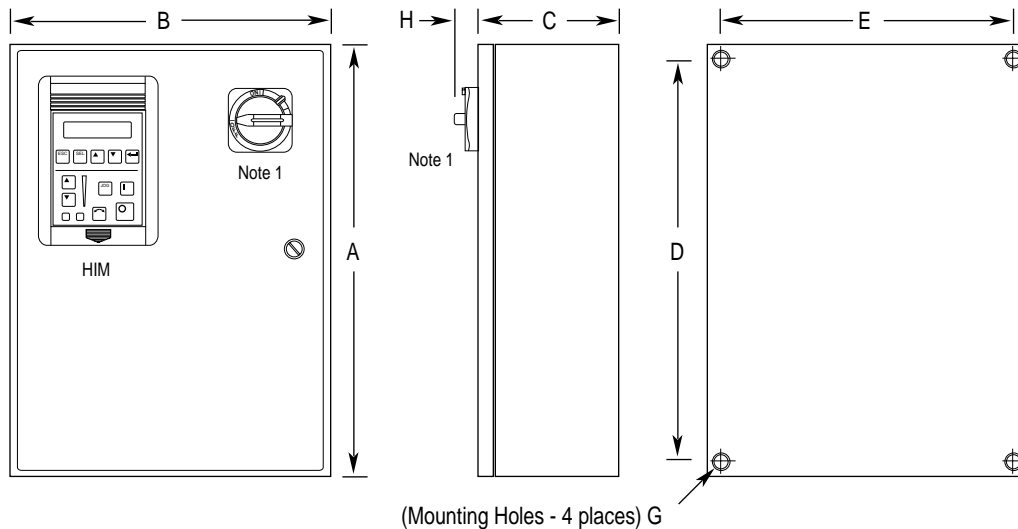

Dimensions are in millimeters (inches)

Option Combinations Not Covered By Special Rule 1	Special Rule #1 Any option combination that includes Bypass	A Height	B Width	C Depth	D	E	G Diameter	H*
AA02-AA04, HA02-HA04, BA01-BA03, NA01-NA03	-	350.0 (13.78)	400.0 (15.75)	232.7 (9.16)	315.0 (12.40)	177.8 (7.00)	6.4 (0.25)	40.5 (1.594)
AA08-AA12, HA08-HA12, BA04-BA09, NA04-NA09	AA02-AA12, HA02-HA12, BA01-BA09, NA01-NA09	609.6 (24.00)	406.4 (16.00)	223.7 (8.81)	571.5 (22.50)	368.3 (14.50)	12.7 (0.50)	40.5 (1.594)

* Disconnect switch or circuit breaker operating handle.

NOTE: The Configured Drives Program shown on these pages is typical of North America. Other locations should contact their local Rockwell Automation office for availability of similar products.

Commitment to Quality

Keeping Your Processes Running is what Drives Our Commitment to Quality

All new drive product designs are a joint effort that involves Development Engineering, Quality Management, Manufacturing Engineering, Component Engineering, Product Marketing and quality personnel from all departments. This detailed process known as industrialization ensures that every aspect of a product is strongly considered before the product is actually built. Each new drive design is put through scores of rigid, demanding Qualification Tests and a comprehensive set of performance tests. Assembled components are qualified and pretested before being shipped to our manufacturing facilities. Printed circuit boards are electrically tested and environmentally stressed under power before they are assembled into a drive. At the end of the assembly line,

each drive is put through two complete function tests, including a fully rated dynamometer test that includes load, speed and power cycling to bring the drive to fully rated operating temperature. As a final test, a 100% system test is performed prior to the drive being packaged and shipped. This stringent testing schedule assures that every portion (output, input, feedback, logic, power and I/O) of every drive proves its integrity before it becomes part of your process.

Our commitment to quality is driven by our commitment to enhancing our customers' success worldwide with products, services and responsiveness that set industry standards for quality and value.

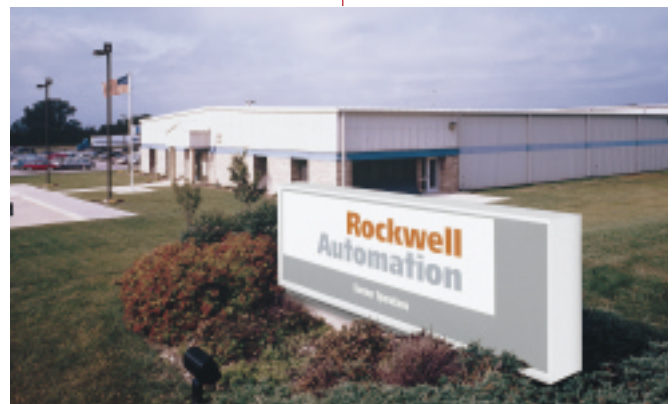

Our drives headquarters and world class manufacturing centers provide drives development, systems engineering, manufacturing, functional testing, customer training and support.

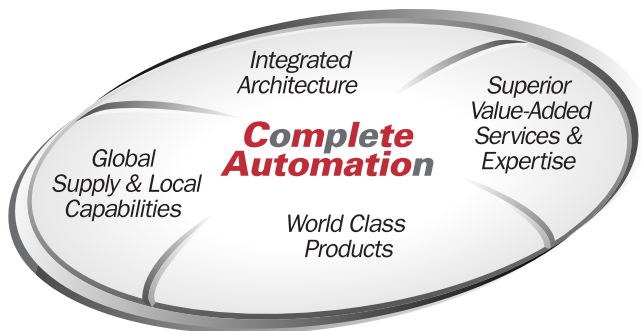

The 1305 AC drive is a world class product that will help to provide you with a single solution for virtually all of your speed control requirements. Its common design and control interface functions will help save you time and money in set-up, integration, and maintenance of your automation system.

For Allen-Bradley Drives support, there are specialists at local sales offices and distributor locations across North America and around the world. We also offer Global Technical Services, specializing in a full spectrum of value-added services and expertise to help simplify maintenance and enhance productivity.

Rockwell Automation is committed to helping you meet ever-changing customer demands for more, less expensive product in less time. Our capabilities enable us to become your "Complete Automation" partner.

1336 FORCE, 1336 IMPACT, DriveTools32, DriveExplorer, Flex, SCANport, CENTERLINE, Complete Automation and the Complete Automation graphic are trademarks of Rockwell Automation.

*Microsoft and Windows are trademarks of Microsoft Corporation.
DeviceNet is a trademark of the Open DeviceNet Vendor Association.
ControlNet is a trademark of ControlNet International, Ltd.*

Reach us now at www.rockwellautomation.com

Wherever you need us, Rockwell Automation brings together leading brands in industrial automation including Allen-Bradley controls, Reliance Electric power transmission products, Dodge mechanical power transmission components, and Rockwell Software. Rockwell Automation's unique, flexible approach to helping customers achieve a competitive advantage is supported by thousands of authorized partners, distributors and system integrators around the world.

Americas Headquarters, 1201 South Second Street, Milwaukee, WI 53204, USA, Tel: (1) 414 382-2000, Fax: (1) 414 382-4444
European Headquarters SA/NV, avenue Herrmann Debroux, 46, 1160 Brussels, Belgium, Tel: (32) 2 663 06 00, Fax: (32) 2 663 06 40
Asia Pacific Headquarters, 27/F Citicorp Centre, 18 Whitfield Road, Causeway Bay, Hong Kong, Tel: (852) 2887 4788, Fax: (852) 2508 1846

