

1305 Connection/Installation Guide

Power Wiring

Input and output power connections are performed through a ten position terminal block, TB1.

(1) Connection for Dynamic Brake Resistors for all models except the 200-230 Volt, 0.37 to 75kW (1/2 to 1 HP) drive.

NOTE: The[DB Enable] parameter must be enabled for proper operation.

(2) For single phase applications, the AC input line can be connected to any two of the three input terminals R, S, T (L1, L2, L3).

(3) Bulletin 1305 drives are UL listed and CSA certified as a motor overload protective device. An external overload relay is not required for single motor applications.

NOTE: This drive is not intended for use with single phase motors.

Power Block Terminal (TB1)

Terminals	Description
GND	Earth Ground
R, S, T (L1, L2, L3)	AC Input Line Terminals
+DC, BRK (or -DC)	Dynamic Brake Option - Refer to instructions included with option
U, V, W (T1, T2, T3)	Motor Connection

Screw Size, Wire Size and Torque Specifications

Terminal	Screw Size	Max. /Min. Wire Size	Maximum Torque
TB1 (230V)	M4	3.5/0.75 (12/18)	0.90 (8)
TB1 (460V)	M4	4/0.75 (10/18)	1.81(16)
TB2 (All)	M3.5	1.5/0.20 (14/24)	0.90 (8)

Control Terminal Block (TB2) Descriptions

Terminal No(s)	Signal	Specification
1,2,3	External Speed Pot	10k Ohm Potentiometer
2,3	0-10V Analog Input	Drive Input Impedance = 100k Ohm
4,3	4-20mA Analog Input	Drive Input Impedance = 250 Ohm
5,3	0-10V Analog Output	Meter Impedance ≥ 4k Ohm
6,7	Start Contact	Closure Input (3)
8,7	Stop Contact	Closure Input (3)
9,10	Programmable Output 1	Resistive Rating = 115 V AC/30 V DC, 5A Inductive Rating = 115 V AC/30 V DC, 2A
11,12	Drive Enable	Contact Closure Input (3)
13,12	Reverse	Contact Closure Input (3)
14,12	Jog	Contact Closure Input (3)
16,15	SW1	Contact Closure Input (3)
17,15	SW2	Contact Closure Input (3)
18,15	SW3	Contact Closure Input (3)
19,20	Programmable Output 2	24V DC +/- 20%, 50 m Amps Max.

(3) Internal 5V supply.

The recommended control signal wire is:

- Belden 8760 (or equiv.) - 18 AWG (0.750 mm²), twisted pair, shielded.
- Belden 8770 (or equiv.) - 18 AWG (0.750 mm²), 3 conductor, shielded.
- Belden 9460 (or equiv.) - 18 AWG (0.750 mm²), twisted pair, shielded.

BULLETIN 1305 CONNECTION GUIDE

POWER WIRING

Input and output power connections are performed through a ten position terminal block, TB1

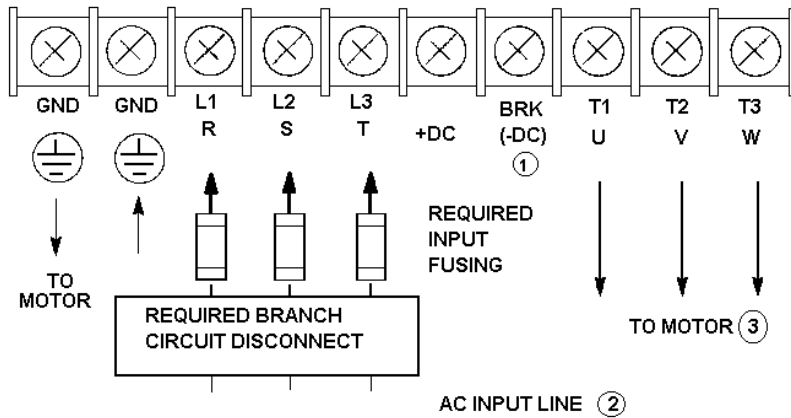

- ① Connection for Dynamic Brake Resistors for all models except the 200-230V, .37 to .75 kW (1/2 to 1 HP) drive. NOTE: the [DB ENABLE] parameter must be enabled for proper operation.
- ② For single phase applications, the AC input line can be connected to any two of the three input terminals R, S, T (L1, L2, L3).
- ③ Bulletin 1305 drives are UL listed and CSA certified as a motor overload protective device. An external overload relay is NOT REQUIRED for single motor applications.

Note: This drive is not intended for use with single phase motors.

BULLETIN 1305 CONNECTION GUIDE

CONTROL TERMINAL BLOCK (TB2) DESIGNATIONS

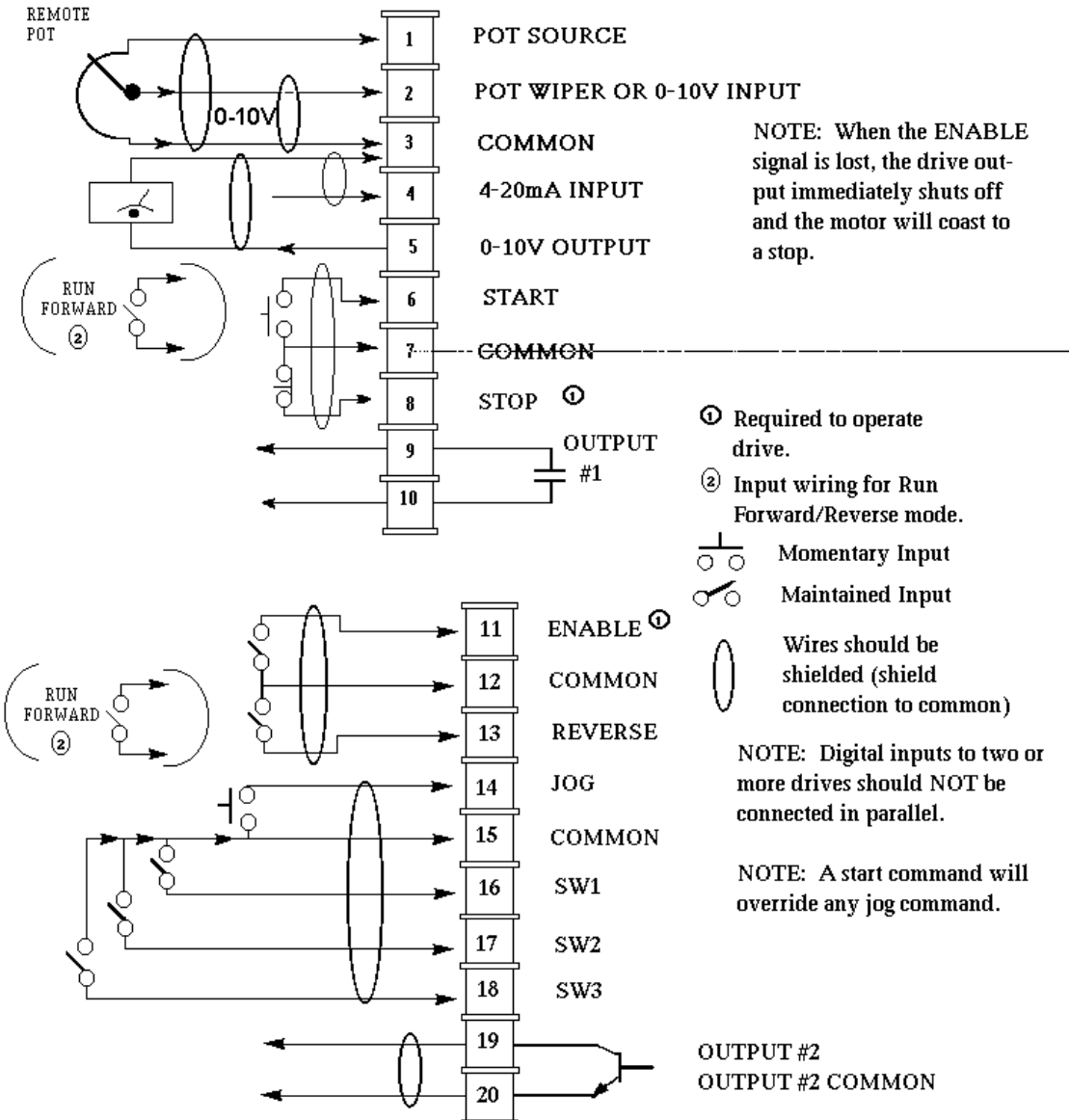

Conduit

If metal conduit is preferred for cable distribution, the following guidelines must be followed.

1. Drives are normally mounted in cabinets and ground connections are made at a common ground point in the cabinet. If the conduit is connected to the motor junction box and at the drive end, no further conduit connections are necessary.
2. No more than three sets of motor leads can be routed through a single conduit. This will minimize “cross talk” that could reduce the effectiveness of the noise reduction methods described. If more than three drive/motor connections per conduit are required, shielded cable as described above must be used. If practical, each conduit should contain only one set of motor leads.



ATTENTION: To avoid a possible shock hazard caused by induced voltages, unused wires in the conduit must be grounded at both ends. For the same reason, if a drive sharing a conduit is being serviced or installed, all drives using this conduit should be disabled. This will eliminate the possible shock hazard from “cross coupled” drive motor leads.

Motor Lead Lengths

Installations with long cable lengths between the 1305 drive and motor may require the use of an output reactor or Terminator. The following guidelines allow for selection of the appropriate drive HP rating (and output reactor or Terminator, if required) to work with an existing motor, and provide motor–lead length solutions for new installations. Voltage doubling at motor terminals, known as reflected wave phenomenon, standing wave or transmission line effect, can occur when using long motor cables with drives. Long motor cables can cause capacitive charging current in excess of the rating of a smaller drive. To ensure proper installation, follow the guidelines provided. All cabling and distances are based on using 14 AWG, 4-conductor type cabling. In general, motors designed and built without phase separating insulation paper between motor windings should be classified as 1000V_{P-P} insulation design.

Section A: No Output Reactor or Terminator

The following Table 4 lists the maximum cable lengths permitted when applying a 460V, 1305 drive to a 460V motor for motor insulation ratings of 1000V, 1200V, and 1600V without an output reactor or Terminator. Shielded and unshielded maximum cable lengths also are listed. Tables are based on operation at nominal line condition (480V).

1000V and 1200V Motor Insulation Ratings:

Cable lengths listed in Table 4 are for operating the 1305 drive at a maximum carrier frequency of 4 kHz on motor insulation ratings of 1000V and 1200V. Consult the factory regarding operation above 4 kHz carrier frequency. Multiply listed distances by 0.85 for operation at high line conditions (above 480V). If the maximum cable length used exceeds the distances indicated, refer to Section B.

1600V Motor Insulation Ratings:

Cable lengths listed in Table 4 are based on operating the 1305 drive at a maximum carrier frequency of 2 kHz on motor insulation ratings of 1600V. Consult the factory regarding operation above 2 kHz carrier frequency. Multiply listed distances by 0.55 for operation at high line conditions (above 480V). If the maximum cable length used exceeds the distances indicated, refer to Section B. The Allen-Bradley 1329-HR is representative of 1600V_{P-P} insulation rating designs and is recommended in applications where long cable lengths are required.

Table 4 Maximum Motor Cable Length Restrictions

Drive HP (460V)	Motor HP(460V)	No External Devices or Reactor at the Motor			
		Using a Motor with Insulation V_{P-P}			
		1000 Volt	1200 Volt	1600 Volt 1329 HR	
		Any Cable	Any Cable	Shielded Cable	Unshielded Cable
Maximum Carrier Frequency		4 kHz	4 kHz	2 kHz	2 kHz
High-Line Derate Multiplier		0.85	0.85	0.55	0.55
5	5	9m (30ft)	30m (100ft)	121m (400ft)	121m (400ft)
	3	9m (30ft)	30m (100ft)	121m (400ft)	121m (400ft)
	2	9m (30ft)	30m (100ft)	121m (400ft)	121m (400ft)
	1	9m (30ft)	30m (100ft)	121m (400ft)	121m (400ft)
	0.5	9m (30ft)	30m (100ft)	121m (400ft)	121m (400ft)
3	3	9m (30ft)	30m (100ft)	91m (300ft)	121m (400ft)
	2	9m (30ft)	30m (100ft)	121m (400ft)	121m (400ft)
	1	9m (30ft)	30m (100ft)	121m (400ft)	121m (400ft)
	0.5	9m (30ft)	30m (100ft)	121m (400ft)	121m (400ft)
2	2	9m (30ft)	30m (100ft)	76m (250ft)	121m (400ft)
	1	9m (30ft)	30m (100ft)	121m (400ft)	121m (400ft)
	0.5	9m (30ft)	30m (100ft)	121m (400ft)	121m (400ft)
1	1	9m (30ft)	30m (100ft)	68m (225ft)	121m (400ft)
	0.5	9m (30ft)	30m (100ft)	121m (400ft)	121m (400ft)
0.5	0.5	9m (30ft)	30m (100ft)	45m (150ft)	106m (350ft)

Section B: Use of Output Reactor or Terminator

For longer motor-lead length applications, an output reactor or Terminator is required to ensure proper drive operation, and for the motor to operate within its specified insulation rating. The guidelines in Table 5 are required for proper drive and motor operation, or motor designs without phase-separating insulation paper between motor windings. Applications with non-inverter duty rated motors, with long lead lengths, require an output reactor or Terminator. An output reactor or Terminator helps reduce voltage reflection to the motor to levels which are less than the motor insulation rating. Table 5 lists maximum cable lengths that can be run when using an output reactor, or one of two available Terminators, for motor insulation ratings of 1000V, 1200V, and 1600V. Shielded and unshielded maximum cable lengths also are listed. When an output reactor is required, locate the reactor at the drive if possible. Consult the factory for applications which require mounting the reactor at the motor.

1000V and 1200V Motor Insulation Ratings:

Cable lengths listed in Table 5 are for operating the 1305 drive at a maximum carrier frequency of 2 kHz on motor insulation ratings of 1000V and 1200V when used with an output reactor or Terminator. Consult the factory regarding operation above 2 kHz carrier frequency. Multiply listed distances by 0.85 for operation at high line conditions (above 480V).

1600V Motor Insulation Ratings:

Cable lengths listed in Table 5 are based on operating the 1305 drive at a maximum carrier frequency of 2 kHz on motor insulation ratings of 1600V. Consult the factory regarding operation above 2 kHz carrier frequency. The Allen-Bradley 1329-HR is representative of 1600V_{P-P} insulation rating designs and is recommended in applications where long cable lengths are required. Example: An existing installation includes a 2 HP, 1200V motor with a 84-meter (275-foot) cable-length requirement between the 1305 drive and the motor. What are the possible solutions to this installation?

1. Table 4 indicates that either an output reactor or a Terminator is required for this installation example. Consult Table 5 for output reactor, Terminator, and cable types.
2. Table 5 suggests these possible solutions:
 - Install a 1305 2-HP drive with an output reactor installed at the drive, and use unshielded cable.
 - Install a 1305 3-HP drive with an output reactor installed at the drive, and use shielded or unshielded cable.

- Install a 1305 2-HP drive with a 1204-TFA1 Terminator, and use shielded or unshielded cable. Contact Allen-Bradley for further assistance if required.

Table 5 Maximum Motor Cable Length

Drive HP (460V)	Motor HP (460V)	Reactor ¹ at the Drive			With 1204-TFB2 Terminator		With 1204-TFA1 Terminator			
		Using a Motor with Insulation V _{P-P}			Using a Motor with Insulation V _{P-P} 1000 Volt or 1200 Volt		Using a Motor with Insulation V _{P-P}			
		1000 Volt	1200 Volt or 1600 Volt				1000 Volt		1200 Volt	
		Any Cable	Shielded	Unshielded	Shielded	Unshielded	Shielded	Unshielded	Shielded	Unshielded
Maximum Carrier Frequency		2 kHz	2 kHz	2 kHz	2 kHz	2 kHz	2 kHz	2 kHz	2 kHz	2 kHz
High-Line Derating Multiplier		0.85	0.85	0.85	0.85	0.85	0.85	0.85	0.85	0.85
5	5	15m (50ft)	182m (600ft)	182m (600ft)	NR	NR	91m (300ft)	61m (200ft)	91m (300ft)	121m (400ft)
	3	15m (50ft)	182m (600ft)	182m (600ft)	91m (300ft)	121m (400ft)	99m (325ft)	61m (200ft)	152m (500ft)	121m (400ft)
	2	15m (50ft)	182m (600ft)	182m (600ft)	121m (400ft)	182m (600ft)	99m (325ft)	61m (200ft)	182m (600ft)	121m (400ft)
	1	15m (50ft)	182m (600ft)	182m (600ft)	121m (400ft)	182m (600ft)	99m (325ft)	61m (200ft)	182m (600ft)	121m (400ft)
	0.5	15m (50ft)	182m (600ft)	182m (600ft)	182m (600ft)	182m (600ft)	99m (325ft)	61m (200ft)	182m (600ft)	121m (400ft)
3	3	15m (50ft)	91m (300ft)	182m (600ft)	NR	NR	91m (300ft)	61m (200ft)	91m (300ft)	121m (400ft)
	2	15m (50ft)	182m (600ft)	182m (600ft)	91m (300ft)	121m (400ft)	99m (325ft)	61m (200ft)	152m (500ft)	121m (400ft)
	1	15m (50ft)	182m (600ft)	182m (600ft)	91m (300ft)	182m (600ft)	99m (325ft)	61m (200ft)	182m (600ft)	121m (400ft)
	0.5	15m (50ft)	182m (600ft)	182m (600ft)	121m (400ft)	182m (600ft)	99m (325ft)	61m (200ft)	182m (600ft)	121m (400ft)
2	2	15m (50ft)	76m (250ft)	167m (550ft)	NR	NR	91m (300ft)	61m (200ft)	91m (300ft)	121m (400ft)
	1	15m (50ft)	182m (600ft)	182m (600ft)	61m (200ft)	61m (200ft)	99m (325ft)	61m (200ft)	121m (400ft)	121m (400ft)
	0.5	15m (50ft)	182m (600ft)	182m (600ft)	91m (300ft)	121m (400ft)	99m (325ft)	61m (200ft)	152m (500ft)	121m (400ft)
1	1	15m (50ft)	68m (225ft)	152m (500ft)	NR	NR	45m (150ft)	61m (200ft)	45m (150ft)	76m (250ft)
	0.5	15m (50ft)	121m (400ft)	182m (600ft)	NR	NR	76m (250ft)	61m (200ft)	76m (250ft)	121m (400ft)
0.5	0.5	15m (50ft)	45m (150ft)	106m (350ft)	NR	NR	NR	NR	NR	NR

NR = Not Recommended.

1 IMPORTANT: A 3% reactor reduces motor stress but may cause a degradation of motor waveform quality. Reactors must have a turn-to-turn insulating rating of 2100 volts or higher. Reactors are not recommended for lightly loaded applications because over-voltage trips may result at low output frequencies.