



Allen-Bradley

efesotomasyon.com

1336 PLUS Adjustable Frequency AC Drive

with

SENSORLESS VECTOR

0.37-448 kW (0.5 - 600 HP)
FRN 1.xx - 5.xx

1336 PLUS
SENSORLESS VECTOR

User Manual

efesotomasyon.com

**Rockwell
Automation**

Important User Information

Solid state equipment has operational characteristics differing from those of electromechanical equipment. “*Safety Guidelines for the Application, Installation and Maintenance of Solid State Controls*” (Publication SGI-1.1 available from your local Allen-Bradley Sales Office or online at <http://www.ab.com/manuals/gi>) describes some important differences between solid state equipment and hard-wired electromechanical devices. Because of this difference, and also because of the wide variety of uses for solid state equipment, all persons responsible for applying this equipment must satisfy themselves that each intended application of this equipment is acceptable.

In no event will the Allen-Bradley Company be responsible or liable for indirect or consequential damages resulting from the use or application of this equipment.

The examples and diagrams in this manual are included solely for illustrative purposes. Because of the many variables and requirements associated with any particular installation, the Allen-Bradley Company cannot assume responsibility or liability for actual use based on the examples and diagrams.

No patent liability is assumed by Allen-Bradley Company with respect to use of information, circuits, equipment, or software described in this manual.

Reproduction of the contents of this manual, in whole or in part, without written permission of the Allen-Bradley Company is prohibited.

Throughout this manual we use notes to make you aware of safety considerations.



ATTENTION: Identifies information about practices or circumstances that can lead to personal injury or death, property damage, or economic loss.

Attentions help you:

- identify a hazard
- avoid the hazard
- recognize the consequences

Important: Identifies information that is especially important for successful application and understanding of the product.



Shock Hazard labels may be located on or inside the drive to alert people that dangerous voltage may be present.

SCANport is a trademark of Rockwell Automation.

PLC is a registered trademark of Rockwell Automation.

COLOR-KEYED is a registered trademark of Thomas & Betts Corporation.

Summary of Changes

The information below summarizes the changes to the 1336 PLUS User Manual since the last release.

Description of New or Updated Information	See Page(s)
Incorporated 1336S-DU002A-EN-P and 1336 PLUS-5.3DU3 Document Updates.	5-54 & 2-36
Notes added to mounting diagram.	2-1



ATTENTION: With the release of Firmware Version 4.01 & up, the resolution of several parameters has been enhanced to 0.1 units. In some cases this will also affect the Minimum, Maximum and/or Default values of these parameters. Users with PLC or SCANport™ device configurations must make the appropriate programming changes. Failure to do so may result in personal injury and/or equipment damage. The parameters affected are:

Minimum Freq	page 5-11, 5-14
Maximum Freq	page 5-11, 5-14
Maximum Speed	page 5-45
Motor NP Hertz	page 5-13, 5-46
Base Frequency	page 5-53
Break Freq	page 5-52
Accel Time 1	page 5-10
Accel Time 2	page 5-16
Decel Time 1	page 5-10
Decel Time 2	page 5-16
DC Hold Time	page 5-17
S Curve Time	page 5-23

Table of Contents

Information and Precautions

Chapter 1

Manual Objectives	1-1
Software Compatibility	1-1
General Precautions	1-2
Conventions Used in this Manual	1-2
Catalog Number Explanation	1-2
Nameplate Location	1-4

Installation/Wiring

Chapter 2

Mounting	2-1
Installation Guidelines	2-2
AC Supply Source	2-3
Input Power Conditioning	2-4
Input Fusing	2-5
Input Devices	2-6
Electrical Interference – EMI/RFI	2-7
RFI Filtering	2-8
CE Conformity	2-8
Grounding	2-8
Power Cabling	2-11
Control and Signal Wiring	2-21
Control Interface Option – TB3	2-23
Output Devices	2-34
Cable Termination	2-34
Selecting/Verifying Fan Voltage	2-35
Auxiliary Inputs – TB4, TB6	2-36
Auxiliary Output – TB9	2-37
Interface Board Installation and Removal	2-37
Adapter Definitions	2-38

Human Interface Module

Chapter 3

HIM Description	3-1
HIM Operation	3-4
Module Removal	3-15

Start-Up

Chapter 4

Start-Up Procedure	4-1
------------------------------	-----

Programming

Chapter 5

Function Index	5-1
Programming Flow Chart	5-1
Chapter Conventions	5-6

Troubleshooting**Chapter 6**

Fault Descriptions	6-1
Alarms	6-8

**Specifications and
Supplemental Information****Appendix A**

Specifications	A-1
User Supplied Enclosures	A-4
Derating Guidelines	A-5
Parameter Cross Reference – By Number	A-10
Parameter Cross Reference – By Name	A-11
HIM Character Map	A-12
Communications Data Information Format	A-13
Typical Programmable Controller Communications Config.	A-14
Typical Serial Communications Configurations	A-15
Read/Write Parameter Record	A-16

Dimensions**Appendix B****CE Conformity****Appendix C**

Requirements for Conforming Installation	C-1
Filter	C-2
Electrical Configuration	C-3
Grounding	C-3
Mechanical Configuration	C-4

Spare Parts Information**Appendix D**

Information and Precautions

Chapter 1 provides information on the general intent of this manual, gives an overall description of the 1336 PLUS Adjustable Frequency AC Drive and provides a listing of key drive features.

Manual Objectives

This publication provides planning, installation, wiring and diagnostic information for the 1336 PLUS Drive. To assure successful installation and operation, the material presented must be thoroughly read and understood before proceeding. Particular attention must be directed to the Attention and Important statements contained within.

Software Compatibility



ATTENTION: To guard against machine damage and/or personal injury, drives with ratings above 45 kW (60 HP) must not be used with software versions below 1.07. Refer to table below.

Three-Phase Drive Rating ¹			Compatible with Version . . .	Frame Reference
200-240V	380-480V	500-600V		
0.37-0.75 kW 0.5-1 HP	0.37-1.2 kW 0.5-1.5 HP	–	1.05 & Up <i>or</i> 1.06 w/std. Jog ²	A1
1.2-1.5 kW 1.5-2 HP	1.5-2.2 kW 2-3 HP	–	1.05 & Up <i>or</i> 1.06 w/std. Jog ²	A2
2.2-3.7 kW 3-5 HP	3.7 kW 5 HP	–	1.05 & Up <i>or</i> 1.06 w/std. Jog ²	A3
–	5.5-7.5 kW 7.5-10 HP	0.75-3.7 kW 1-5 HP	3.01 & Up (380-480V) 3.02 & Up (500-600V)	A4
5.5-11 kW 7.5-15 HP	5.5-22 kW 7.5-30 HP	5.5-15 kW 7.5-20 HP	1.05 & Up <i>or</i> 1.06 w/std. Jog ²	B1/B2
15-22 kW 20-30 HP	30-45 kW 40-60 HP	18.5-45 kW 25-60 HP	1.05 & Up <i>or</i> 1.06 w/std. Jog ²	C
30-45 kW 40-60 HP	45-112 kW 60-150 HP	56-93 kW 75-125 HP	2.01 & Up	D
56-93 kW 75-125 HP	112-187- kW 150-250 HP	112-187 kW 150-250 HP	2.01 & Up	E
–	112-336- kW 250-450 HP	187-336 kW 250-450 HP	4.01 & Up	F
–	187-448 kW 250-600 HP	224-448 kW 300-600 HP	2.01 & Up	G

¹ kW and HP are constant torque.

² See pages 2–28 and 2–29.

General Precautions



ATTENTION: This drive contains ESD (Electrostatic Discharge) sensitive parts and assemblies. Static control precautions are required when installing, testing, servicing or repairing this assembly. Component damage may result if ESD control procedures are not followed. If you are not familiar with static control procedures, reference A-B publication 8000-4.5.2, “Guarding Against Electrostatic Damage” or any other applicable ESD protection handbook.



ATTENTION: An incorrectly applied or installed drive can result in component damage or a reduction in product life. Wiring or application errors, such as, undersizing the motor, incorrect or inadequate AC supply, or excessive ambient temperatures may result in malfunction of the system.



ATTENTION: Only personnel familiar with the 1336 PLUS Adjustable Frequency AC Drive and associated machinery should plan or implement the installation, start-up and subsequent maintenance of the system. Failure to comply may result in personal injury and/or equipment damage.



ATTENTION: To avoid a hazard of electric shock, verify that the voltage on the bus capacitors has discharged before performing any work on the drive. Measure the DC bus voltage at the + & – terminals of TB1. The voltage must be zero.

Conventions Used in this Manual

To help differentiate parameter names and display text from other text in this manual, the following conventions will be used:

- Parameter Names will appear in [brackets]
- Display Text will appear in “quotes”

Catalog Number Explanation

The diagram on the following page describes the 1336 PLUS catalog numbering scheme.

1336S

First Position
Bulletin Number

BR

Second Position
Voltage

Letter	Voltages
AQ	200-240V AC or 310V DC
BR	380-480V AC or 513-620V DC
CW	500-600V AC or 775V DC

or

A	200-240V AC
B	380-480V AC
BP	380-480V AC (F Frame)
BX	Special Rating
C	500-600V AC
Q	310V DC
R	513-620V DC
RX	Special Rating
W	775V DC

F30

Third Position
Nominal HP Rating

Code	kW (HP)
F05	0.37 (0.5)
F07	0.56 (0.75)
F10	0.75 (1)
F15	1.2 (1.5)
F20	1.5 (2)
F30	2.2 (3)
F50	3.7 (5)
F75	5.5 (7.5)
F100	7.5 (10)

007	5.5 (7.5)
010	7.5 (10)
015	11 (15)
020	15 (20)
025	18.5 (25)
030	22 (30)
040	30 (40)
050	37 (50)
060	45 (60)
075	56 (75)
100	75 (100)
125	93 (125)
150	112 (150)
200	149 (200)
250	187 (250) ¹
300	224 (300) ¹
350	261 (350) ¹
400	298 (400) ¹
450	336 (450) ¹
500	373 (500) ¹
600	448 (600) ¹

AA

Fourth Position
Enclosure Type

Code	Type
AA	IP 20 (NEMA 1)
AE	IP 20 (NEMA 1)/ EMC
	0.37-45 kW (0.5-60 HP) only
AF	IP 65 (NEMA 4) ²
AJ	IP 54 (NEMA 12) ²
AN	IP 00 (Open)

EN

Fifth Position
Language

Code	Language
EN3	English/English V3.04
EN4	English/English V4.xx
FR3	English/French V3.04
FR4	English/French V4.xx
DE3	English/German V3.04
DE4	English/German V4.xx
IT3	English/Italian V3.04
IT4	English/Italian V4.xx
ES3	English/Spanish V3.04
ES4	English/Spanish V4.xx

MODS

Sixth Position
Options

efesotomasyon.com

Code Description

Human Interface Module, IP 20 (Type 1)

HAB	Blank – No Functionality
HAP	Programmer Only
HA1	Programmer/Controller w/Analog Pot
HA2	Programmer/Controller w/Digital Pot

Human Interface Module, IP 65/54 (Type 4/12)

HJP	Programmer Only
HJ2	Programmer/Controller w/Digital Pot

Code Description

Communication Options

GM1	Single Point Remote I/O
GM2	RS-232/422/485, DF1 & DH485
GM5	DeviceNet

Control Interface Options

L4	TTL Contact
L4E	TTL Contact & Encoder Feedback
L5	24V AC/DC
L5E	24V AC/DC & Encoder Feedback
L6	115V AC
L6E	115V AC & Encoder Feedback

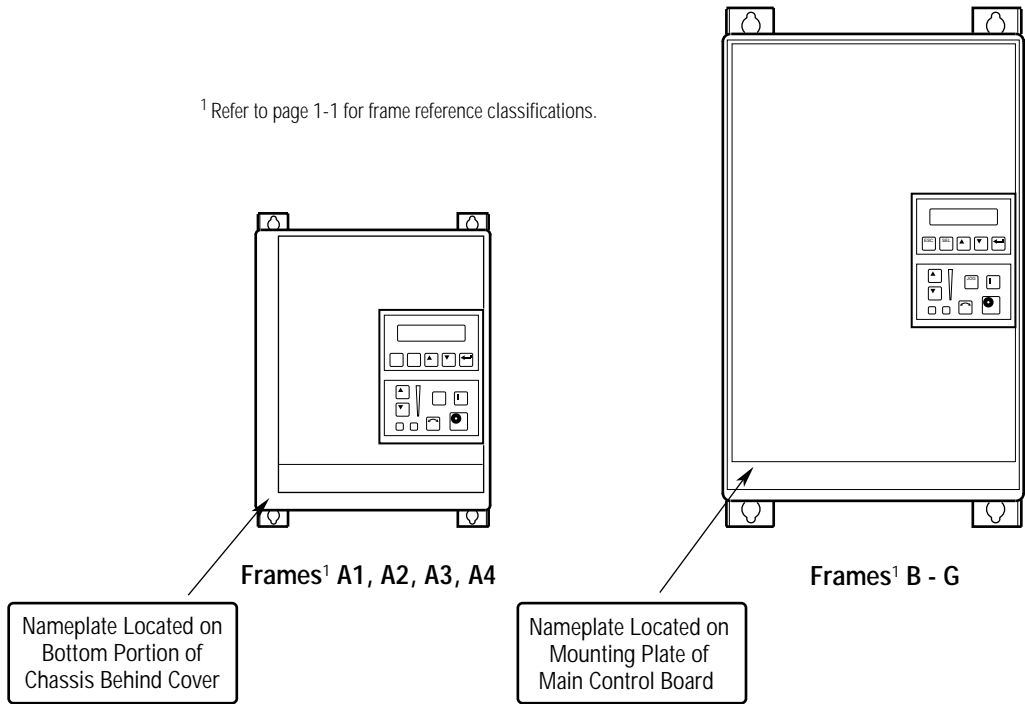
¹ G Frame Drives in enclosed construction are supplied through the *Configured Drives Program*.

² D through G Frame drives in IP 65 (NEMA Type 4) and IP 54 (NEMA Type 12) configurations are supplied through the *Configured Drives Program*.

Nameplate Location

1336 PLUS Nameplate Location

¹ Refer to page 1-1 for frame reference classifications.



Installation/Wiring

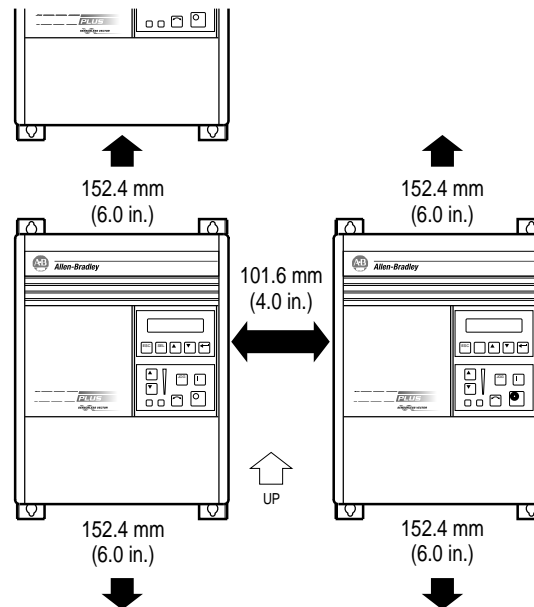
Chapter 2 provides the information you need to properly mount and wire the 1336 PLUS Drive. Since most start-up difficulties are the result of incorrect wiring, every precaution must be taken to assure that the wiring is done as instructed. All items must be read and understood before the actual installation begins.



ATTENTION: The following information is merely a guide for proper installation. The Allen-Bradley Company cannot assume responsibility for the compliance or the noncompliance to any code, national, local or otherwise for the proper installation of this drive or associated equipment. A hazard of personal injury and/or equipment damage exists if codes are ignored during installation.

Mounting

Minimum Mounting Requirements for Proper Heat Dissipation (Dimensions shown are between drives or other devices)

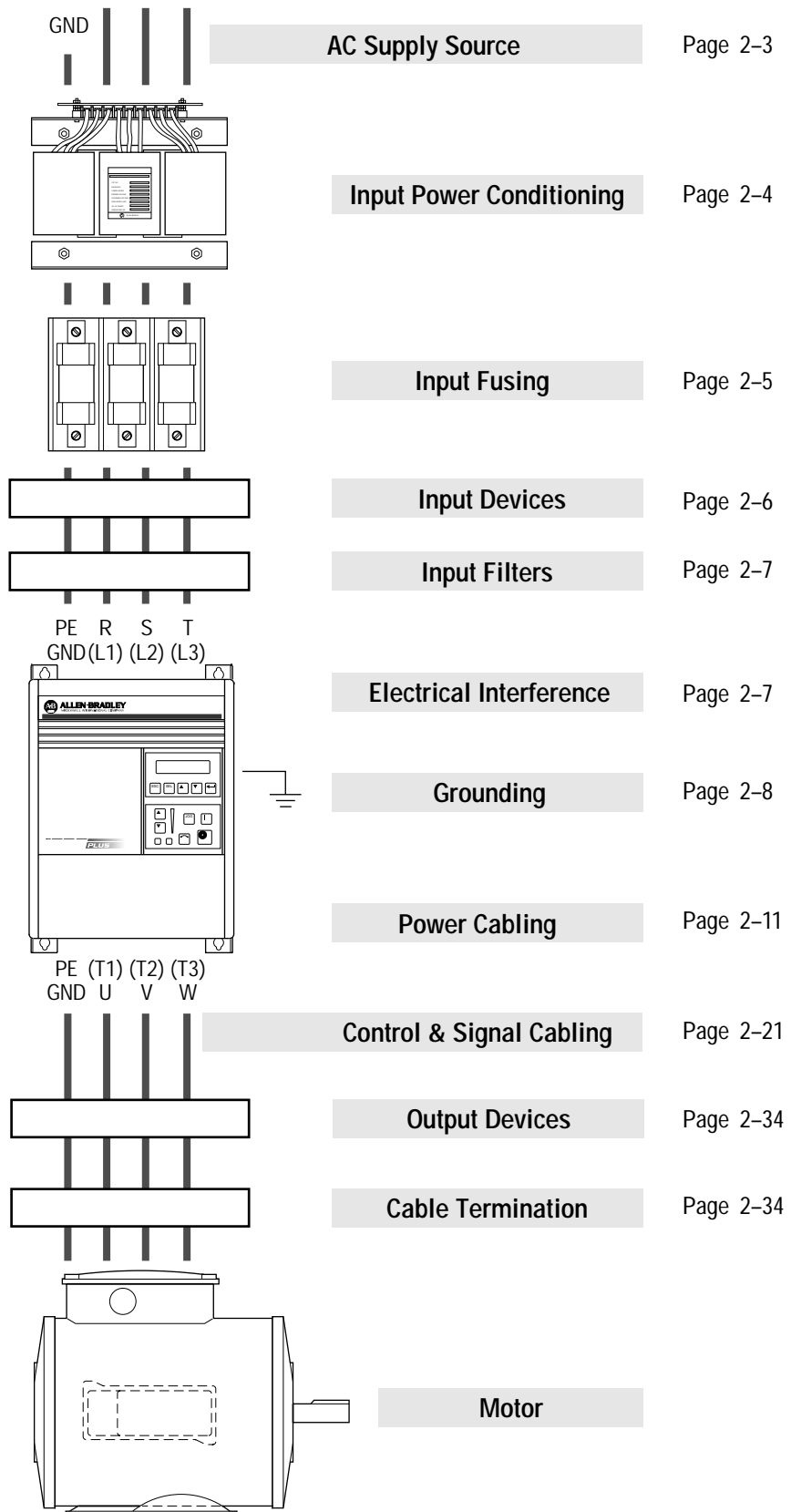


Important:

A4 Frame drives should not be mounted on a combustible surface. However, if the drive must be mounted on a combustible surface, 6.35 mm (0.25 in.) spacers must be provided under the mounting feet of the drive.

F Frame drives require a minimum of 152.4 mm (6.0 in.) between the drive back and mounting wall, if drives are mounted with sides touching another device or wall. A minimum of 76.2 mm (3.0 in.) is required on the sides if the back of the drive is mounted against a wall or other device.

Installation Guidelines



AC Supply Source

1336 PLUS drives are suitable for use on a circuit capable of delivering up to a maximum of 200,000 rms symmetrical amperes, 600 volts maximum when used with the AC input line fuses specified in Table 2.A.



ATTENTION: To guard against personal injury and/or equipment damage caused by improper fusing, use only the recommended line fuses specified in Table 2.A.

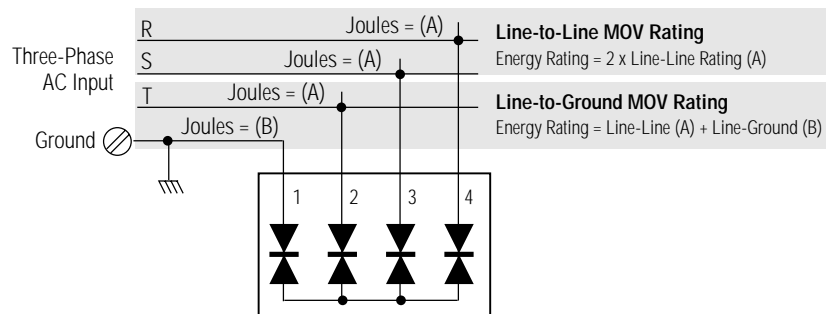
Unbalanced Distribution Systems

This drive is designed to operate on three-phase supply systems whose line voltages are symmetrical. Surge suppression devices are included to protect the drive from lightning induced overvoltages between line and ground. Where the potential exists for abnormally high phase-to-ground voltages (in excess of 125% of nominal), or where the supply ground is tied to another system or equipment that could cause the ground potential to vary with operation, suitable isolation is required for the drive. Where this potential exists, an isolation transformer is strongly recommended.

Ungrounded Distribution Systems

All 1336 PLUS drives are equipped with an MOV (Metal Oxide Varistor) that provides voltage surge protection and phase-to-phase plus phase-to-ground protection which is designed to meet IEEE 587. The MOV circuit is designed for surge suppression only (transient line protection), not continuous operation.

With ungrounded distribution systems, the phase-to-ground MOV connection could become a continuous current path to ground. Energy ratings are listed below. Exceeding the published line-to-line and line-to-ground voltage ratings may cause physical damage to the MOV. Refer to page A-1.



Frame Reference	A			B-C			D-G		
Device Rating (V)	240	480	600	240	480	600	240	480	600
Line-Line (A)	160	140	NA	160	160	160	140	140	150
Line-Ground (B)	220	220	NA	220	220	220	220	220	220

Input Power Conditioning

In general, the 1336 PLUS is suitable for direct connection to an AC line of the correct voltage. Certain conditions can exist, however, that prompt consideration of a line reactor or isolation transformer ahead of the drive.

The basic rules to aid in determining whether a line reactor or isolation transformer should be considered are as follows:

1. If the AC source experiences frequent power outages or significant voltage transients, users should calculate the kVA_{max} (see formula below). If the source transformer kVA exceeds the calculated kVA_{max} and the drive is installed close to the source, it is an indication that there may be enough energy behind these voltage transients to cause nuisance input fuse blowing, overvoltage faults or drive power structure damage. In these cases, a line reactor or isolation transformer should be considered.

$$Z_{drive} (\Omega/\Phi) = \frac{V_{line-line}}{\sqrt{3} \times \text{Input Amps}}$$

$$VA_{max} = \frac{(V_{line-line})^2 \times \% \text{ Source Leakage (5-6\% typical)}}{Z_{drive} \times 0.01}$$

2. If the AC source does not have a neutral or one phase referenced to ground (see *Unbalanced Distribution Systems* on page 2-3), an isolation transformer with the neutral of the secondary grounded is **highly recommended**. If the line-to-ground voltages on any phase can exceed 125% of the nominal line-to-line voltage, an isolation transformer with the neutral of the secondary grounded, is **highly recommended**.
3. If the AC line supplying the drive has power factor correction capacitors that are switched in and out, an isolation transformer or 5% line reactor is recommended between the drive and capacitors. If the capacitors are permanently connected and not switched, the general rules above apply.

Input Fusing



ATTENTION: The 1336 PLUS does not provide input power short circuit fusing. Specifications for the recommended fuse size and type to provide drive input power protection against short circuits are provided. Branch circuit breakers or disconnect switches cannot provide this level of protection for drive components.

Table 2.A
Maximum Recommended AC Input Line Fuse Ratings (fuses are user supplied)

European Installations	North American Installations	Drive Catalog Number	kW (HP) Rating	200-240V Rating	380-480V Rating	500-600V Rating
<p>The recommended fuse is Class gG, general industrial applications and motor circuit protection.</p> <p>BS88 (British Standard) Parts 1 & 2*, EN60269-1, Parts 1 & 2, type gG or equivalent should be used for these drives. Fuses that meet BS88 Parts 1 & 2 are acceptable for Frames A - F.</p> <p>* Typical designations include, but may not be limited to the following: Parts 1 & 2: AC, AD, BC, BD, CD, DD, ED, EFS, EF, FF, FG, GF, GG, GH.</p>	<p>UL requirements specify that UL Class CC, T or J¹ fuses must be used for all drives in this section*.</p> <p>* Typical designations include: Type CC: KTK, FNQ-R Type J: JKS, LPJ Type T: JJS, JJN</p>	1336S-__ F05, 7	0.37-0.56 (0.5-0.75)	6A ²	3A ²	-
		1336S-__ F10	0.75 (1)	10A ²	6A ²	6A ²
		1336S-__ F15	1.2 (1.5)	15A ²	6A ²	-
		1336S-__ F20	1.5 (2)	15A ²	10A ²	10A ²
		1336S-__ F30	2.2 (3)	25A ²	15A ²	15A ²
		1336S-__ F50	3.7 (5)	40A ²	20A ²	20A ²
		1336S-__ F75	5.5 (7.5)	-	20A ²	-
		1336S-__ F100	7.5 (10)	-	30A ²	-
		1336S-__ 007	5.5 (7.5)	40A	20A	15A
		1336S-__ 010	7.5 (10)	50A	30A	20A
		1336S-__ 015	11 (15)	70A	35A	25A
		1336S-__ 020	15 (20)	100A	45A	35A
		1336S-__ 025	18.5 (25)	100A	60A	40A
		1336S-__ 030	22 (30)	125A	70A	50A
		1336S-__ 040	30 (40)	150A	80A	60A
		1336S-__ 050	37 (50)	200A	100A	80A
		1336S-__ X060	45 (60)	-	100A	-
		1336S-__ 060	45 (60)	250A	125A	90A
		1336S-__ 075	56 (75)	300A	150A	110A
		1336S-__ 100	75 (100)	400A	200A	150A
		1336S-__ 125	93 (125)	450A	250A	175A
		1336S-__ X150	112 (150)	-	250A	-
		1336S-__ 150	112 (150)	-	300A	225A
1336S-__ 200	149 (200)	-	400A	350A		
1336S-__ 250	187 (250)	-	450A	400A		
1336S-__ X300	224 (300)	-	-	400A		
<p>The recommended fuse is Class gG, general industrial applications and motor circuit protection.</p> <p>BS88 (British Standard) Part 4, EN60269-1, Part 4*, type gG semiconductor fuses or equivalent should be used for these drives. G Frame drives require semiconductor fuses and should be fused with Part 4 fuses.</p> <p>* Typical designations include, but may not be limited to the following: Part 4: CT, ET, FE, EET, FEE, RFE, FM, FMM.</p>	<p>Bussmann FWP/Gould Shawmut A-70Q or QS semiconductor type fuses must be used for all drives in this section.</p>	1336S-__ P250 ³	187 (250)	-	450A ³	-
		1336S-__ X250	187 (250)	-	450A	-
		1336S-__ 300	224 (300)	-	450A	400A
		1336S-__ P300 ³	224 (300)	-	500A ³	-
		1336S-__ 350	261 (350)	-	500A	450A
		1336S-__ P350 ³	261 (350)	-	600A ³	-
		1336S-__ 400	298 (400)	-	600A	500A
		1336S-__ P400 ³	298 (400)	-	600A ³	-
		1336S-__ 450	336 (450)	-	800A	600A
		1336S-__ P450 ³	336 (450)	-	700A ³	-
		1336S-__ 500	373 (500)	-	800A	800A
		1336S-__ 600	448 (600)	-	900A	800A

¹ Both fast acting and slow blow are acceptable.

² Dual element-time delay fuses are required.

³ Fuses are supplied with F Frame drives.

Input Devices

Starting and Stopping the Motor



ATTENTION: The drive start/stop control circuitry includes solid-state components. If hazards due to accidental contact with moving machinery or unintentional flow of liquid, gas or solids exist, an additional hardwired stop circuit may be required to remove AC line power to the drive. When AC power is removed, there will be a loss of inherent regenerative braking effect & the motor will coast to a stop. An auxiliary braking method may be required.

Repeated Application/Removal of Input Power



ATTENTION: The drive is intended to be controlled by control input signals that will start and stop the motor. A device that routinely disconnects then reapplies line power to the drive for the purpose of starting and stopping the motor is not recommended.

Bypass Contactors



ATTENTION: An incorrectly applied or installed bypass system can result in component damage or reduction in product life. The most common causes are:

- Wiring AC line to drive output or control terminals.
- Improper bypass or output circuits not approved by Allen-Bradley.
- Output circuits which do not connect directly to the motor.

Contact Allen-Bradley for assistance with application or wiring.

Electrical Interference – EMI/RFI

Immunity

The immunity of 1336 PLUS drives to externally generated interference is good. Usually, no special precautions are required beyond the installation practices provided in this publication.

It is recommended that the coils of DC energized contactors associated with drives be suppressed with a diode or similar device, since they can generate severe electrical transients.

Emission

Careful attention must be given to the arrangement of power and ground connections to the drive to avoid interference with nearby sensitive equipment. The cable to the motor carries switched voltages and should be routed well away from sensitive equipment.

The ground conductor of the motor cable should be connected to the drive ground (PE) terminal directly. Connecting this ground conductor to a cabinet ground point or ground bus bar may cause high frequency current to circulate in the ground system of the enclosure. The motor end of this ground conductor must be solidly connected to the motor case ground.

Shielded or armored cable may be used to guard against radiated emissions from the motor cable. The shield or armor should be connected to the drive ground (PE) terminal and the motor ground as outlined above.

Common mode chokes at the drive output can help reduce common mode noise on installations that do not use shielded cable. Common mode chokes can also be used on analog or communication cables. Refer to page 2-34 for further information.

An RFI filter can be used and in most situations provides an effective reduction of RFI emissions that may be conducted into the main supply lines.

If the installation combines a drive with sensitive devices or circuits, it is recommended that the lowest possible drive PWM carrier frequency be programmed.

RFI Filtering

1336 PLUS drives can be installed with an RFI filter, which controls radio-frequency conducted emissions into the main supply lines and ground wiring.

If the cabling and installation recommendation precautions described in this manual are adhered to, it is unlikely that interference problems will occur when the drive is used with conventional industrial electronic circuits and systems. However, a filter may be required if there is a likelihood of sensitive devices or circuits being installed on the same AC supply.

Where it is essential that very low emission levels must be achieved or if conformity with standards is required the optional RFI filter must be used. Refer to *Appendix C* and instructions included with the filter for installation and grounding information.

CE Conformity

Refer to *Appendix C*.

Grounding

Refer to the grounding diagram on page 2-10. The drive must be connected to system ground at the power ground (PE) terminal provided on the power terminal block (TB1). Ground impedance must conform to the requirements of national and local industrial safety regulations (NEC, VDE 0160, BSI, etc.) and should be inspected and tested at appropriate and regular intervals.

In any cabinet, a single, low-impedance ground point or ground bus bar should be used. All circuits should be grounded independently and directly. The AC supply ground conductor should also be connected directly to this ground point or bus bar.

Sensitive Circuits

It is essential to define the paths through which the high frequency ground currents flow. This will assure that sensitive circuits do not share a path with such current. Control and signal conductors should not be run near or parallel to power conductors.

Motor Cable

The ground conductor of the motor cable (drive end) must be connected directly to the drive ground (PE) terminal, not to the enclosure bus bar. Grounding directly to the drive (and filter, if installed) can provide a direct route for high frequency current returning from the motor frame and ground conductor. At the motor end, the ground conductor should also be connected to the motor case ground.

If shielded or armored cables are used, the shield/armor should also be grounded at both ends as described above.

Encoder & Communications Cabling

If encoder connections or communications cables are used, the wiring must be separated from power cabling. This can be accomplished with carefully routed, shielded cable (ground cable shield at the drive end only) or a separate steel conduit (grounded at both ends). Belden 9730, 8777 (or equivalent) is recommended for encoder cable runs less than 30 meters (100 feet). Belden 9773 (or equivalent) is recommended for encoder cable runs greater than 30 meters (100 feet).

Discrete Control and Signal Wiring

The control and signal wiring must be grounded at a single point in the system, remote from the drive. This means the 0V or ground terminal should be grounded at the equipment end, not the drive end. If shielded control and signal wires are used, the shield must also be grounded at this point.

If the control and signal wires are short, and contained within a cabinet which has no sensitive circuits, the use of shielded control and signal wiring is not necessary. The recommended control signal wire is:

- Belden 8760 (or equiv.)—0.750 mm² (18 AWG), twisted pair, shielded.
- Belden 8770 (or equiv.)—0.750 mm² (18 AWG), 3 conductor, shielded.
- Belden 9460 (or equiv.)—0.750 mm² (18 AWG), twisted pair, shielded.

Shield Termination – TE (True Earth)

The TE terminal block (not available on 0.37-7.5 kW (0.5-10 HP) A Frame drives) is used for all control signal shields internal to the drive. It must be connected to an earth ground by a separate continuous lead. Refer to Figure 2.1/2.3 for location.

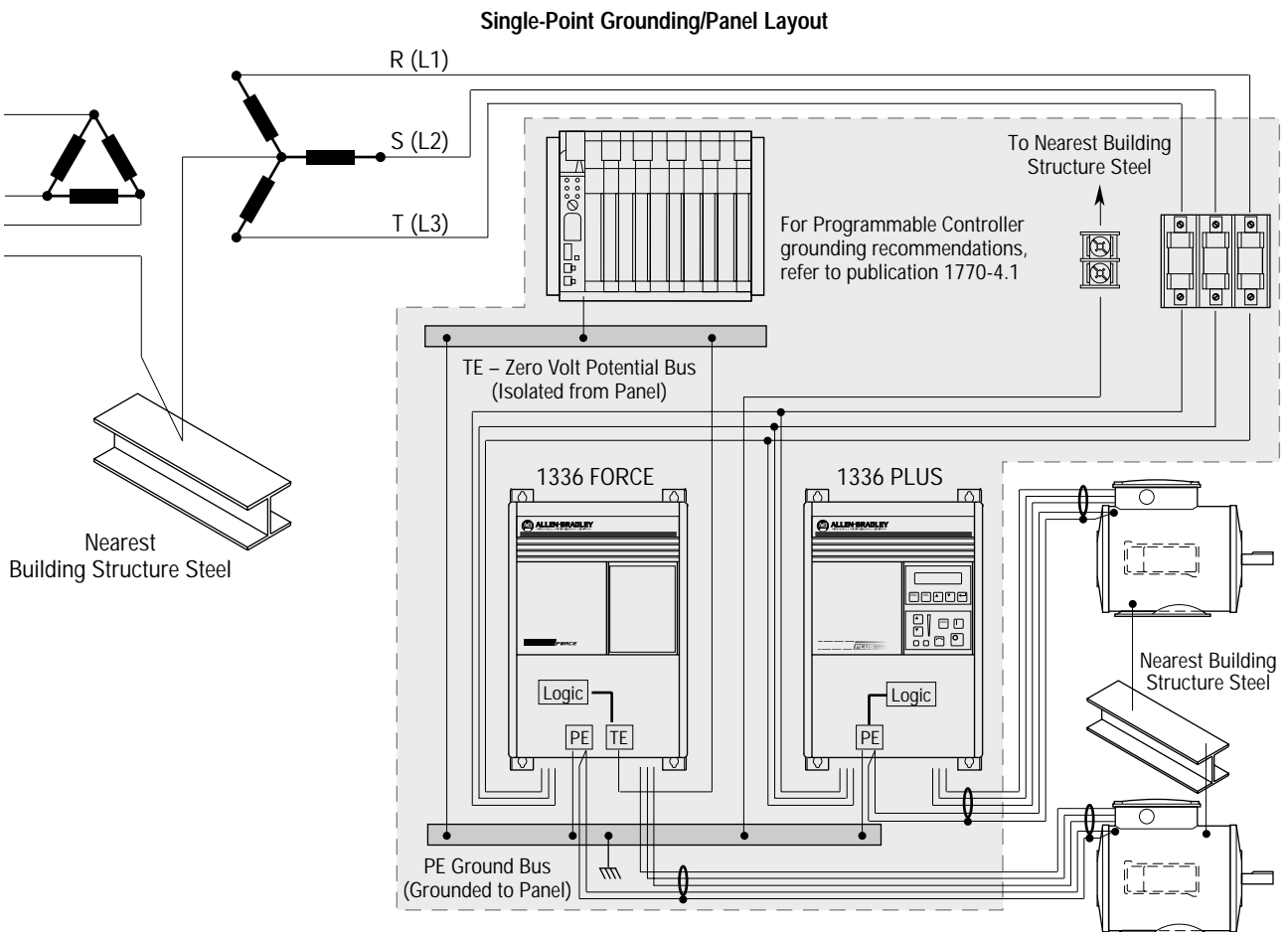
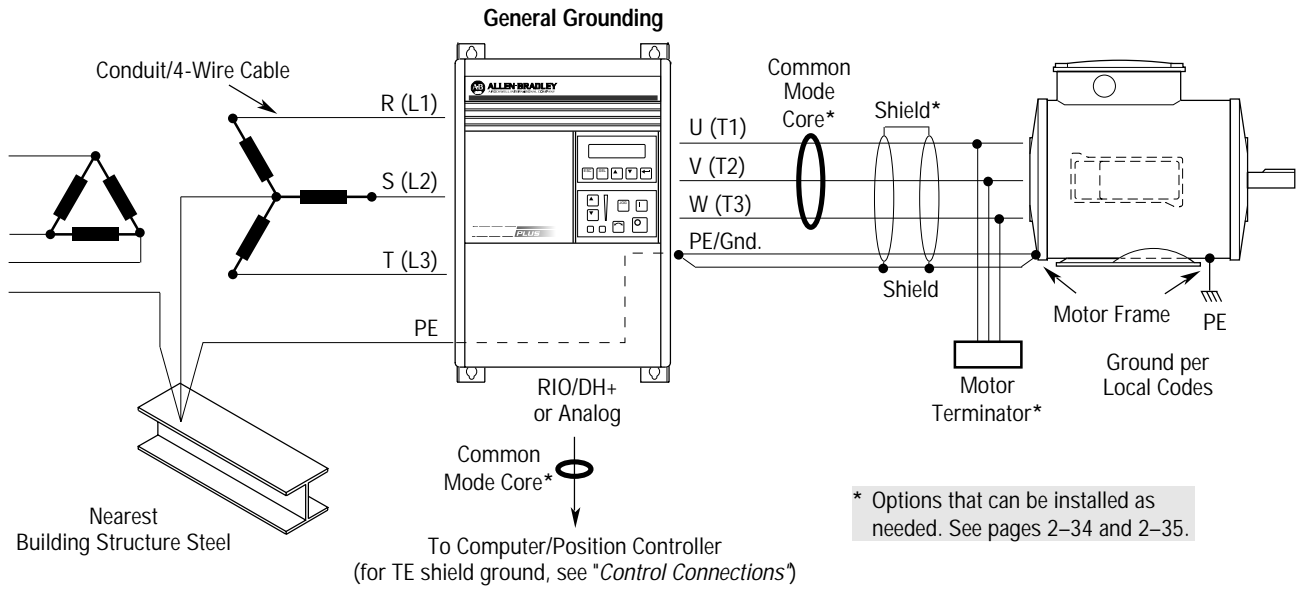
The maximum and minimum wire size accepted by this block is 2.1 and 0.30 mm² (14 and 22 AWG). Maximum torque is 1.36 N-m (12 lb.-in.). Use Copper wire Only.

Safety Ground – PE

This is the safety ground required by code. This point must be connected to adjacent building steel (girder, joist) or a floor ground rod, provided grounding points comply with NEC regulations. If a cabinet ground bus is used, refer to *Grounding* on page 2-8.

RFI Filter

Important: Using an optional RFI filter may result in relatively high ground leakage currents. Surge suppression devices are also incorporated in the filter. Therefore, the filter must be permanently installed and solidly grounded to the supply neutral. Grounding must not rely on flexible cables and should not include any form of plug or socket that would permit inadvertent disconnection. The integrity of this connection should be periodically checked.



Important: Grounding requirements will vary with the drives being used. Drives with True Earth (TE) terminals must have a zero potential bus, separate from potential earth (PE) ground bus. Note that buses can be tied together at one point in the control cabinet or brought back separately to the building ground grid (tied within 3 meters (10 feet)).

Power Cabling

Input and output power connections are performed through terminal block, TB1 (see Figure 2.1 for location).

Important: For maintenance and setup procedures, the drive may be operated without a motor connected.

Table 2.B
TB1 Signals

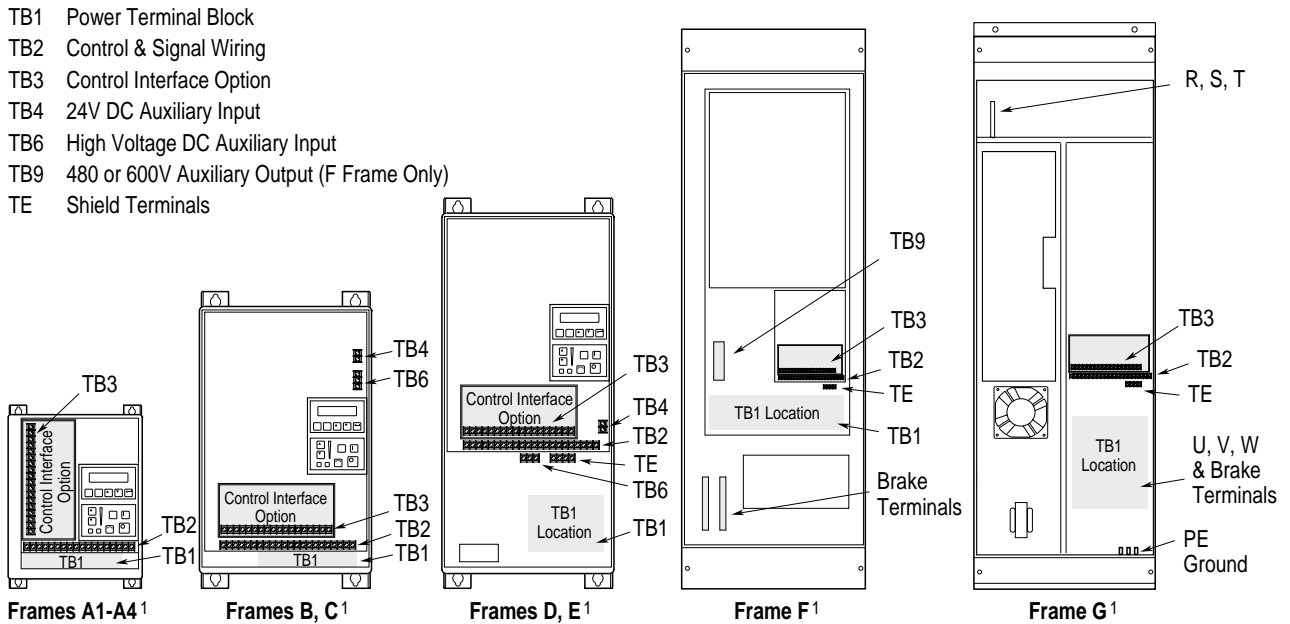
Terminal	Description
PE	Potential Earth Ground
TE	Shield Termination - True Earth
R (L1), S (L2), T (L3)	AC Line Input Terminals
+DC, -DC	DC Bus Terminals
U (T1), V (T2), W (T3)	Motor Connection

efesotomasyon.com



ATTENTION: The National Codes and standards (NEC, VDE, BSI etc.) and local codes outline provisions for safely installing electrical equipment. Installation must comply with specifications regarding wire types, conductor sizes, branch circuit protection and disconnect devices. Failure to do so may result in personal injury and/or equipment damage.

Figure 2.1
Terminal Block Locations



¹ Refer to page 1-1 for frame reference classifications and Figure 2.2 for TB1 details.

Table 2.C
TB1 Specifications – Use 75° C Copper wire Only

Drive Frame Size	Max./Min. Wire Size ¹ <i>mm² (AWG)</i>	Maximum Torque <i>N-m (lb.-in.)</i>
A1-A4 (page 2-18)	5.3/0.8 (10/18)	1.81 (16)
B1 (page 2-18)	8.4/0.8 (8/18)	1.81 (16)
B2 (page 2-18)	13.3/0.5 (6/20)	1.70 (15)
C (page 2-18)	26.7/0.8 (3/18)	5.65 (50)
D (page 2-19) ³	127.0/2.1 (250 MCM/14) 67.4/2.1 (00/14) ²	6.00 (52) 6.00 (52)
E (page 2-19) ³	253.0/2.1 (500 MCM/14)	10.00 (87)
F (page 2-20) ³	303.6/2.1 (600 MCM/14)	23.00 (200)
G (page 2-20) ³	303.6/2.1 (600 MCM/14)	23.00 (200)

¹ Wire sizes given are maximum/minimum sizes that TB1 will accept – these are not recommendations.

² Applies to 30 kW (40 HP) 200-240V, 45 & 56 kW (60 & 75 HP) 380-480V, 56 kW (75 HP) 500-600V drives only.

³ These configurations of TB1 are stud type terminations and require the use of lug type connectors to terminate field installed conductors. Lug kits are available for use with these configurations. Wire size used is determined by selecting the proper lug based on the drive catalog number. Refer to Table 2.D.

Lug Kits

D, E, F and G Frame drives have stud type terminals and/or bus bars/bolts that require standard “crimp type” connectors for cable termination. Connectors such as T & B Color-Keyed[®] connectors (or equivalent) are recommended. The following table shows the lug selection for one possible cable choice. Connectors for each installation should be chosen based on desired cable sizes, the application requirements and all applicable national, state and local codes. See the minimum/maximum values for wire size per Table 2.C.

Table 2.D
Lug Selection

Drive Catalog Number	AC Input R, S, T Output U, V, W and PE		DC+ DC- ²		TE	
	Cable (per Phase) Qty. mm ² (AWG)	T&B Part No. ³ Qty. Number	Cable (per Phase) Qty. mm ² (AWG)	T&B Part No. ³ Qty. Number	Cable (per Phase) Qty. mm ² (AWG)	T&B Part No. ³ Qty. Number
1336S-A040	(1) 53.5 (1/0)	(8) 54153 ¹	(1) 13.3 (6)	(2) 54135 ¹	(1) 13.3 (6)	(1) 54135 ¹
1336S-A050	(1) 85.0 (3/0)	(8) 54163 ¹	(1) 13.3 (6)	(2) 54135 ¹	(1) 13.3 (6)	(1) 54135 ¹
1336S-A060	(1) 107.2 (4/0)	(8) 54168 ¹	(1) 13.3 (6)	(2) 54135 ¹	(1) 21.2 (4)	(1) 54139 ¹
1336S-A075	(2) 53.5 (1/0)	(8) 54109T (8) 54109B	(1) 33.6 (2)	(2) 54109	(1) 21.2 (4)	(1) 54139 ¹
1336S-A100	(2) 85.0 (3/0)	(8) 54111T (8) 54111B	(1) 42.4 (1)	(2) 54148	(1) 33.6 (2)	(1) 54142 ¹
1336S-A125	(2) 107.2 (4/0)	(8) 54112T (8) 54112B	(1) 67.4 (2/0)	(2) 54110	(1) 33.6 (2)	(1) 54142 ¹
1336S-B060	(1) 42.4 (1)	(8) 54147 ¹	(1) 8.4 (8)	(2) 54131 ¹	(1) 13.3 (6)	(1) 54135 ¹
1336S-B075	(1) 53.5 (1/0)	(8) 54153 ¹	(1) 13.3 (6)	(2) 54135 ¹	(1) 13.3 (6)	(1) 54135 ¹
1336S-B100	(1) 85.0 (3/0)	(8) 54163 ¹	(1) 13.3 (6)	(2) 54135 ¹	(1) 13.3 (6)	(1) 54135 ¹
1336S-B125	(1) 107.2 (4/0)	(8) 54168 ¹	(1) 26.7 (3)	(2) 54147 ¹	(1) 21.2 (4)	(1) 54139 ¹
1336S-BX150	(1) 107.2 (4/0)	(8) 54168 ¹	(1) 26.7 (3)	(2) 54147 ¹	(1) 21.2 (4)	(1) 54139 ¹
1336S-B150	(2) 53.5 (1/0)	(8) 54109T (8) 54109B	(1) 33.6 (2)	(2) 54110	(1) 21.2 (4)	(1) 54139 ¹
1336S-B200	(2) 85.0 (3/0)	(8) 54111T (8) 54111B	(1) 42.4 (1)	(2) 54148	(1) 26.7 (3)	(1) 54142 ¹
1336S-B250	(2) 107.2 (4/0)	(8) 54112T (8) 54112B	(1) 67.4 (2/0)	(2) 54110	(1) 33.6 (2)	(1) 54142 ¹
1336S-BX250	(3) 53.5 (1/0)	(24) 54109	(1) 67.4 (2/0)	(2) 54110	NA	NA
1336S-BP250	(3) 53.5 (1/0)	(24) 54109	(1) 67.4 (2/0)	(2) 54110	NA	NA
1336S-B300	(3) 67.4 (2/0)	(24) 54110	(1) 42.4 (1)	(2) 54148	NA	NA
1336S-BP300	(3) 67.4 (2/0)	(24) 54110	(1) 42.4 (1)	(2) 54148	NA	NA
1336S-B350	(3) 85.0 (3/0)	(24) 54111	(1) 42.4 (1)	(2) 54148	NA	NA
1336S-BP350	(3) 85.0 (3/0)	(24) 54111	(1) 42.4 (1)	(2) 54148	NA	NA
1336S-B400	(3) 107.2 (4/0)	(24) 54112	(1) 42.4 (1)	(2) 54148	NA	NA
1336S-BP400	(3) 107.2 (4/0)	(24) 54112	(1) 42.4 (1)	(2) 54148	NA	NA
1336S-B450	(3) 127.0 (250 MCM)	(24) 54174	(1) 42.4 (1)	(2) 54148	NA	NA
1336S-BP450	(3) 127.0 (250 MCM)	(24) 54174	(1) 42.4 (1)	(2) 54148	NA	NA
1336S-B500	(3) 152.0 (300 MCM)	(24) 54179	(1) 53.5 (1/0)	(2) 54109	NA	NA
1336S-B600	(3) 152.0 (300 MCM)	(24) 54179	(1) 53.5 (1/0)	(2) 54109	NA	NA
1336S-C075	(1) 33.6 (2)	(8) 54142 ¹	(1) 13.3 (6)	(2) 54135 ¹	(1) 8.4 (8)	(1) 54131 ¹
1336S-C100	(1) 53.5 (1/0)	(8) 54153 ¹	(1) 13.3 (6)	(2) 54135 ¹	(1) 13.3 (6)	(1) 54135 ¹
1336S-C125	(1) 67.4 (2/0)	(8) 54158 ¹	(1) 26.7 (3)	(2) 54147 ¹	(1) 13.3 (6)	(1) 54135 ¹
1336S-C150	(1) 107.2 (4/0)	(8) 54111	(1) 42.4 (1)	(2) 54148	(1) 13.3 (6)	(1) 54135 ¹
1336S-C200	(2) 67.4 (2/0)	(8) 54110T (8) 54110B	(1) 42.4 (1)	(2) 54148	(1) 26.7 (3)	(1) 54142 ¹
1336S-C250	(2) 85.0 (3/0)	(8) 54111T (8) 54111B	(1) 67.4 (2/0)	(2) 54110	(1) 26.7 (3)	(1) 54142 ¹
1336S-CX300	(3) 85.0 (3/0)	(16) 54111	Consult Factory		NA	NA
1336S-C300	(3) 85.0 (3/0)	(16) 54111			NA	NA
1336S-C350	(3) 53.5 (1/0)	(24) 54109			NA	NA
1336S-C400	(3) 67.4 (2/0)	(24) 54110			NA	NA
1336S-C450	(3) 85.0 (3/0)	(24) 54111			NA	NA
1336S-C500	(3) 107.2 (4/0)	(24) 54112			NA	NA
1336S-C600	(3) 127.0 (250 MCM)	(24) 54174			NA	NA

¹ 5/16" Stud. All other studs are 3/8".

² Lugs shown for DC+/- are based on dynamic brake sizing of 50% of (motor rating X 1.25). Select proper lugs based on required braking torque. Refer to 1336-5.64 or 1336-5.65 for additional information.

³ T & B COLOR-KEYED[®] Connectors require T & B WT117 or TBM-6 Crimper tool or equivalent. Lugs should be crimped according to manufacturer's tool instructions. If required, Rockwell Automation can supply lug kits for lugs shown above. Kits do not include crimping tools. Consult factory for kit information.

Motor Cables

A variety of cable types are acceptable for drive installations. For many installations, unshielded cable is adequate, provided it can be separated from sensitive circuits. As an approximate guide, allow a spacing of 0.3 meters (1 foot) for every 10 meters (32.8 feet) of length. In all cases, long parallel runs must be avoided. Do not use cable with an insulation thickness less than or equal to 15 mils.

The cable should be 4-conductor with the ground lead being connected directly to the drive ground terminal (PE) and the motor frame ground terminal.

Shielded Cable

Shielded cable is recommended if sensitive circuits or devices are connected or mounted to the machinery driven by the motor. The shield must be connected to both the drive ground (drive end) and motor frame ground (motor end). The connection must be made at both ends to minimize interference.

If cable trays or large conduits are to be used to distribute the motor leads for multiple drives, shielded cable is recommended to reduce or capture the noise from the motor leads and minimize “cross coupling” of noise between the leads of different drives. The shield should be connected to the ground connections at both the motor and drive end.

Armored cable also provides effective shielding. Ideally it should be grounded only at the drive (PE) and motor frame. Some armored cable has a PVC coating over the armor to prevent incidental contact with grounded structure. If, due to the type of connector, the armor is grounded at the cabinet entrance, shielded cable should be used within the cabinet if power leads will be run close to control signals.

In some hazardous environments it is not permissible to ground both ends of the cable armor because of the possibility of high current circulating at the input frequency if the ground loop is cut by a strong magnetic field. This only applies in the proximity of powerful electrical machines. In such cases, consult factory for specific guidelines.

Conduit

If metal conduit is preferred for cable distribution, the following guidelines must be followed.

- Drives are normally mounted in cabinets and ground connections are made at a common ground point in the cabinet. Normal installation of conduit provides grounded connections to both the motor frame ground (junction box) and drive cabinet ground. These ground connections help minimize interference. This is a noise reduction recommendation only, and does not affect the requirements for safety grounding (refer to pages 2-8 and 2-9).
- No more than three sets of motor leads can be routed through a single conduit. This will minimize “cross talk” that could reduce the effectiveness of the noise reduction methods described. If more than three drive/motor connections per conduit are required, shielded cable as described above must be used. If practical, each conduit should contain only one set of motor leads.



ATTENTION: To avoid a possible shock hazard caused by induced voltages, unused wires in the conduit must be grounded at both ends. For the same reason, if a drive sharing a conduit is being serviced or installed, all drives using this conduit should be disabled. This will eliminate the possible shock hazard from “cross coupled” drive motor leads.

Motor Lead Lengths

Installations with long cables to the motor may require the addition of output reactors or cable terminators to limit voltage reflections at the motor. Refer to Tables 2.E and 2.F for the maximum length cable allowed for various installation techniques.

For installations that exceed the recommended maximum lengths listed, contact the factory.

Table 2.E
Maximum Motor Cable Length Restrictions in meters (feet) – 380V-480V Drives¹

Drive Frame	Drive kW (HP)	Motor kW (HP)	No External Devices				w/ 1204-TFB2 Term.			w/ 1204-TFA1 Terminator					Reactor at Drive ²								
			Motor				Motor			Motor					Motor								
			A	B	1329	1329R/L	A or B		1329	A		B		1329	A	B or 1329							
			Any Cable	Any Cable	Any Cable	Any Cable ⁷	Cable Type		Any Cable	Cable Type		Cable Type		Any Cable	Any Cable	Any Cable							
				Shld. ³		Unshld.	Shld. ³		Unshld.														
A1	0.37 (0.5)	0.37 (0.5)	12.2 (40)	33.5 (110)	91.4 (300)	91.4 (300)	Use 1204-TFA1						30.5 (100)	61.0 (200)	30.5 (100)	61.0 (200)	91.4 (300)	22.9 (75)	182.9 (600)				
	0.75 (1)	0.75 (1)	12.2 (40)	33.5 (110)	91.4 (300)	91.4 (300)							30.5 (100)	30.5 (100)	30.5 (100)	30.5 (100)	91.4 (300)	22.9 (75)	182.9 (600)				
	0.37 (0.5)	0.37 (0.5)	12.2 (40)	33.5 (110)	91.4 (300)	91.4 (300)							30.5 (100)	61.0 (200)	30.5 (100)	61.0 (200)	91.4 (300)	22.9 (75)	182.9 (600)				
A2	1.2 (1.5)	1.2 (1.5)	12.2 (40)	33.5 (110)	91.4 (300)	91.4 (300)	Use 1204-TFB2						30.5 (100)	30.5 (100)	61.0 (200)	61.0 (200)	91.4 (300)	22.9 (75)	182.9 (600)				
		0.75 (1)	12.2 (40)	33.5 (110)	91.4 (300)	91.4 (300)							30.5 (100)	30.5 (100)	61.0 (200)	61.0 (200)	91.4 (300)	22.9 (75)	182.9 (600)				
		0.37 (0.5)	12.2 (40)	33.5 (110)	114.3 (375)	121.9 (400)							30.5 (100)	30.5 (100)	61.0 (200)	61.0 (200)	121.9 (400)	22.9 (75)	182.9 (600)				
	1.5 (2)	1.5 (2)	7.6 (25)	12.2 (40)	91.4 (300)	91.4 (300)							91.4 (300)	91.4 (300)	91.4 (300)	30.5 (100)	30.5 (100)	91.4 (300)	61.0 (200)	91.4 (300)	22.9 (75)	182.9 (600)	
		1.2 (1.5)	7.6 (25)	12.2 (40)	114.3 (375)	182.9 (600)							91.4 (300)	182.9 (600)	182.9 (600)	30.5 (100)	30.5 (100)	91.4 (300)	61.0 (200)	182.9 (600)	22.9 (75)	182.9 (600)	
		0.75 (1)	7.6 (25)	12.2 (40)	114.3 (375)	182.9 (600)							182.9 (600)	182.9 (600)	182.9 (600)	30.5 (100)	30.5 (100)	91.4 (300)	61.0 (200)	182.9 (600)	22.9 (75)	182.9 (600)	
		0.37 (0.5)	7.6 (25)	12.2 (40)	114.3 (375)	182.9 (600)							182.9 (600)	182.9 (600)	182.9 (600)	30.5 (100)	30.5 (100)	91.4 (300)	61.0 (200)	182.9 (600)	22.9 (75)	182.9 (600)	
	2.2 (3)	2.2 (3)	7.6 (25)	12.2 (40)	91.4 (300)	91.4 (300)							182.9 (600)	182.9 (600)	182.9 (600)	Use 1204-TFB2						22.9 (75)	182.9 (600)
		1.5 (2)	7.6 (25)	12.2 (40)	114.3 (375)	182.9 (600)							182.9 (600)	182.9 (600)	182.9 (600)							22.9 (75)	182.9 (600)
		0.75 (1)	7.6 (25)	12.2 (40)	114.3 (375)	182.9 (600)							182.9 (600)	182.9 (600)	22.9 (75)							182.9 (600)	
		0.37 (0.5)	7.6 (25)	12.2 (40)	114.3 (375)	182.9 (600)							182.9 (600)	182.9 (600)	22.9 (75)							182.9 (600)	
	A3	3.7 (5)	3.7 (5)	7.6 (25)	12.2 (40)	114.3 (375)							Note For applications/ installations using new motors, no restrictions in lead length due to voltage reflection are necessary. You should observe standard practices for voltage drop, cable capacitance, and other issues.	182.9 (600)	182.9 (600)							182.9 (600)	Use 1204-TFB2
2.2 (3)			7.6 (25)	12.2 (40)	114.3 (375)	182.9 (600)	182.9 (600)	182.9 (600)	22.9 (75)	182.9 (600)													
1.5 (2)			7.6 (25)	12.2 (40)	114.3 (375)	182.9 (600)	182.9 (600)	182.9 (600)	22.9 (75)	182.9 (600)													
0.75 (1)			7.6 (25)	12.2 (40)	114.3 (375)	182.9 (600)	182.9 (600)	182.9 (600)	22.9 (75)	182.9 (600)													
0.37 (0.5)			7.6 (25)	12.2 (40)	114.3 (375)	182.9 (600)	182.9 (600)	182.9 (600)	22.9 (75)	182.9 (600)													
A4	5.5-7.5 (7.5-10)	5.5-7.5 (7.5-10)	7.6 (25)	12.2 (40)	114.3 (375)	182.9 (600)	182.9 (600)	182.9 (600)	24.4 (80)	182.9 (600)													
B	5.5-22 (7.5-30)	5.5-22 (7.5-30)	7.6 (25)	12.2 (40)	114.3 (375)	182.9 (600)	182.9 (600)	182.9 (600)	24.4 (80)	182.9 (600)													
C	30-45 (X40-X60)	30-45 (40-60)	7.6 (25)	12.2 (40)	114.3 (375)	182.9 (600)	182.9 (600)	182.9 (600)	76.2 (250)	182.9 (600)													
D	45-112 (60-X150)	45-112 (60-150)	12.2 (40)	30.5 (100)	114.3 (375)	182.9 (600)	182.9 (600)	182.9 (600)	61.0 (200)	91.4 (300)													
E	112-187 (150-250)	112-224 (150-300)	12.2 (40)	53.3 (175)	114.3 (375)	182.9 (600)	182.9 (600)	182.9 (600)	182.9 (600)	182.9 (600)													
F	187-336 (250-450)	187-336 (250-450)	18.3 (60)	53.3 (175)	114.3 (375)	182.9 (600)	182.9 (600)	182.9 (600)	182.9 (600)	182.9 (600)													
G	187-448 (X250-600)	187-448 (250-600)	18.3 (60)	53.3 (175)	114.3 (375)	182.9 (600)	182.9 (600)	182.9 (600)	182.9 (600)	182.9 (600)													

Type A Motor Characteristics: No phase paper or misplaced phase paper, lower quality insulation systems, corona inception voltages between 850 and 1000 volts.

Type B Motor Characteristics: Properly placed phase paper, medium quality insulation systems, corona inception voltages between 1000 and 1200 volts.

1329R Motors: These AC Variable Speed motors are "Power Matched" for use with Allen-Bradley Drives. Each motor is energy efficient and designed to meet or exceed the requirements of the Federal Energy Act of 1992. All 1329R motors are optimized for variable speed operation and include premium inverter grade insulation systems which meet or exceed NEMA MG1. Part 31.40.4.2.

Table 2.F
Maximum Motor Cable Length Restrictions in meters (feet) – 500V-600V Drives⁴

Drive Frame	Drive kW (HP)	Motor kW (HP)	No External Devices			w/ 1204-TFB2 Terminator			w/ 1204-TFA1 Terminator			Reactor at Drive ²		
			Motor			Motor			Motor			Motor		
			A	B	1329R/L Motors ⁶	A	B	1600V or 1329R/L ⁶	A	B	1600V or 1329R/L	A	B	1600V or 1329R/L
Any Cable	Any Cable	Any Cable	Any Cable	Any Cable	Any Cable	Any Cable	Any Cable	Any Cable	Any Cable	Any Cable	Any Cable	Any Cable		
A4	0.75 (1)	0.75 (1)	NR	NR	182.9 (600)	NR	182.9 (600)	335.3 (1100)	NR	61.0 (200)	182.9 (600)	Not Recommended		
		0.37 (0.5)	NR	NR	182.9 (600)	NR	182.9 (600)	335.3 (1100)	NR	61.0 (200)	182.9 (600)			
	1.5 (2)	1.5 (2)	NR	NR	182.9 (600)	NR	182.9 (600)	335.3 (1100)	NR	61.0 (200)	182.9 (600)			
		1.2 (1.5)	NR	NR	182.9 (600)	NR	182.9 (600)	335.3 (1100)	NR	61.0 (200)	182.9 (600)			
		0.75 (1)	NR	NR	182.9 (600)	NR	182.9 (600)	335.3 (1100)	NR	61.0 (200)	182.9 (600)			
		0.37 (0.5)	NR	NR	182.9 (600)	NR	182.9 (600)	335.3 (1100)	NR	61.0 (200)	182.9 (600)			
	2.2 (3)	2.2 (3)	NR	NR	182.9 (600)	NR	182.9 (600)	335.3 (1100)	NR	61.0 (200)	182.9 (600)			
		1.5 (2)	NR	NR	182.9 (600)	NR	182.9 (600)	335.3 (1100)	NR	61.0 (200)	182.9 (600)			
		0.75 (1)	NR	NR	182.9 (600)	NR	182.9 (600)	335.3 (1100)	NR	61.0 (200)	182.9 (600)			
		0.37 (0.5)	NR	NR	182.9 (600)	NR	182.9 (600)	335.3 (1100)	NR	61.0 (200)	182.9 (600)			
	3.7 (5)	3.7 (5)	NR	NR	182.9 (600)	NR	182.9 (600)	335.3 (1100)	NR	61.0 (200)	182.9 (600)			
		2.2 (3)	NR	NR	182.9 (600)	NR	182.9 (600)	335.3 (1100)	NR	61.0 (200)	182.9 (600)			
		1.5 (2)	NR	NR	182.9 (600)	NR	182.9 (600)	335.3 (1100)	NR	61.0 (200)	182.9 (600)			
		0.75 (1)	NR	NR	182.9 (600)	NR	182.9 (600)	335.3 (1100)	NR	61.0 (200)	182.9 (600)			
		0.37 (0.5)	NR	NR	182.9 (600)	NR	182.9 (600)	335.3 (1100)	NR	61.0 (200)	182.9 (600)			
B	5.5-15 (7.5-20)	5.5-15 (7.5-20)	NR	9.1 (30)	182.9 (600)	91.4 (300)	182.9 (600)	⁵	NR	61.0 (200)	⁵	30.5 (100)	91.4 (300)	182.9 (600)
C	18.5-45 (25-60)	18.5-45 (25-60)	NR	9.1 (30)	182.9 (600)	91.4 (300)	182.9 (600)	⁵	NR	61.0 (200)	⁵	30.5 (100)	91.4 (300)	182.9 (600)
D	56-93 (75-125)	56-93 (75-125)	NR	9.1 (30)	182.9 (600)	91.4 (300)	182.9 (600)	⁵	NR	61.0 (200)	⁵	61.0 (200)	91.4 (300)	182.9 (600)
E	112-224 (150-X300)	112-224 (150-X300)	NR	9.1 (30)	182.9 (600)	91.4 (300)	182.9 (600)	⁵	NR	61.0 (200)	⁵	182.9 (600)	182.9 (600)	182.9 (600)
F	187-336 (250-450)	187-336 (250-450)	NR	9.1 (30)	182.9 (600)	91.4 (300)	182.9 (600)	⁵	NR	61.0 (200)	⁵	182.9 (600)	182.9 (600)	182.9 (600)
G	224-448 (300-600)	224-448 (300-600)	NR	9.1 (30)	182.9 (600)	91.4 (300)	182.9 (600)	⁵	NR	61.0 (200)	⁵	182.9 (600)	182.9 (600)	182.9 (600)

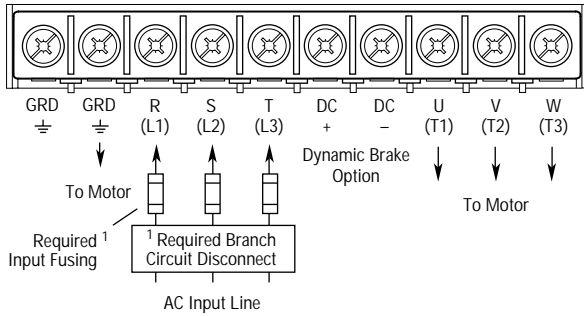
NR = Not Recommended

- ¹ Values shown are for 480V nominal input voltage and drive carrier frequency of 2 kHz. Consult factory regarding operation at carrier frequencies above 2 kHz. Multiply values by 0.85 for high line conditions. For input voltages of 380, 400 or 415V AC, multiply the table values by 1.25, 1.20 or 1.15, respectively.
- ² A 3% reactor reduces motor and cable stress but may cause a degradation of motor waveform quality. Reactors must have a turn-turn insulation rating of 2100 volts or higher.
- ³ Includes wire in conduit.
- ⁴ Values shown are for nominal input voltage and drive carrier frequency of 2 kHz. Consult factory regarding operation at carrier frequencies above 2 kHz. Multiply values by 0.85 for high line conditions.
- ⁵ Information not available at time of printing.
- ⁶ These distances require **new** 1329R or 1329L motors. New motors at 600V are rated at approximately 1850V insulation value. These distances are only valid with firmware version 4.03 or higher.
- ⁷ These distance restrictions are due to charging of cable capacitance and may vary from application to application. These distances are only valid with firmware version 3.04 or higher.

Figure 2.2
Terminal Block TB1

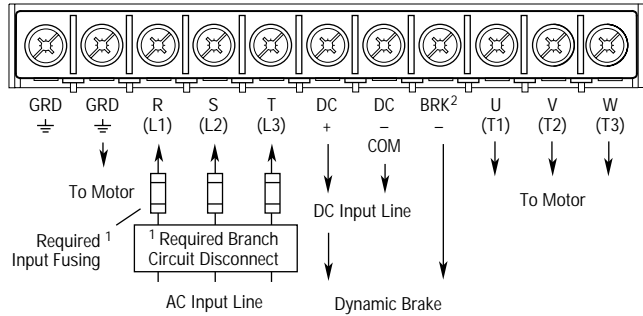
A1-A3 Frame

200-240V, 0.37-3.7 kW (0.5-5 HP) Terminal Designations
380-480V, 0.37-3.7 kW (0.5-5 HP) Terminal Designations



A4 Frame

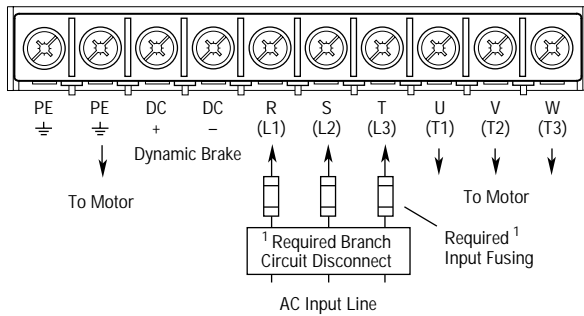
380-480V, 5.5-7.5 kW (7.5-10 HP) Terminal Designations
500-600V, 0.75-3.7 kW (1-5 HP) Terminal Designations



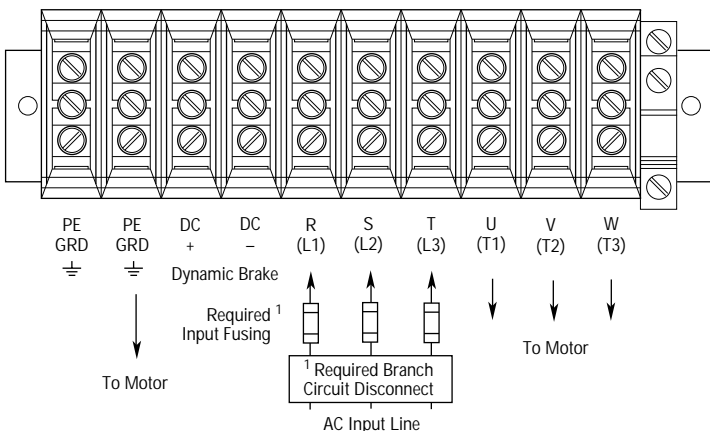
Important: A brake malfunction will occur if the Dynamic Brake is connected to "DC - COM"

B1 Frame

200-240V, 5.5 kW (7.5 HP) Terminal Designations
380-480/500-600V, 5.5-11 kW (7.5-15 HP) Terminal Designations

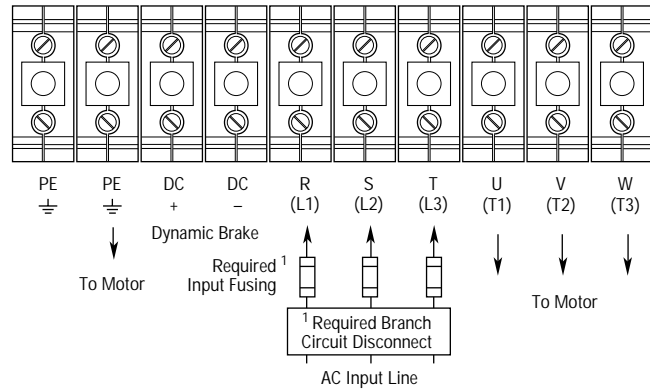


200-240V, 15-22 kW (20-30 HP) Terminal Designations
380-480V, 30-45 kW (40-60 HP) Terminal Designations
500-600V, 18.5-45 kW (25-60 HP) Terminal Designations



B2 Frame

200-240V, 7.5-11 kW (10-15 HP) Terminal Designations
380-480V, 15-22 kW (20-30 HP) Terminal Designations
500-600V, 15 kW (20 HP) Terminal Designations



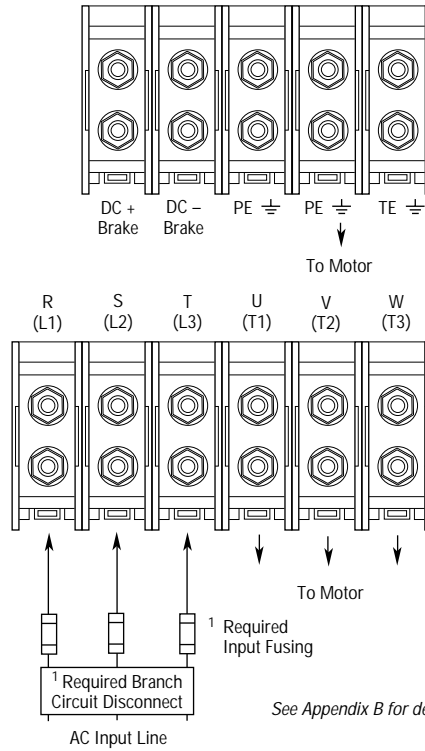
C Frame

efesotomasyon.com

¹ User supplied.
² Terminal located separately on Series A Drives.

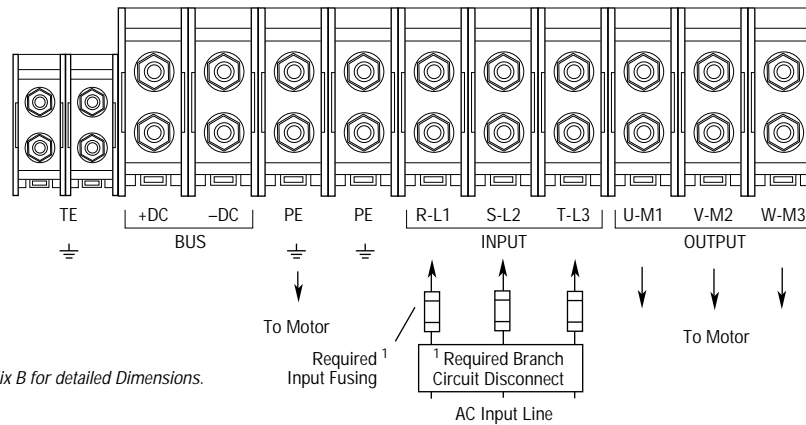
200-240V, 30-45 kW (40-60 HP) Terminal Designations
 380-480V, 45-112 kW (60-150 HP) Terminal Designations
 500-600V, 56-112 kW (75-150 HP) Terminal Designations

D Frame



200-240V, 56-75 kW (75-100 HP) Terminal Designations
 380-480V, 112-187 kW (150-250 HP) Terminal Designations
 500-600V, 112-224 kW (150-300 HP) Terminal Designations

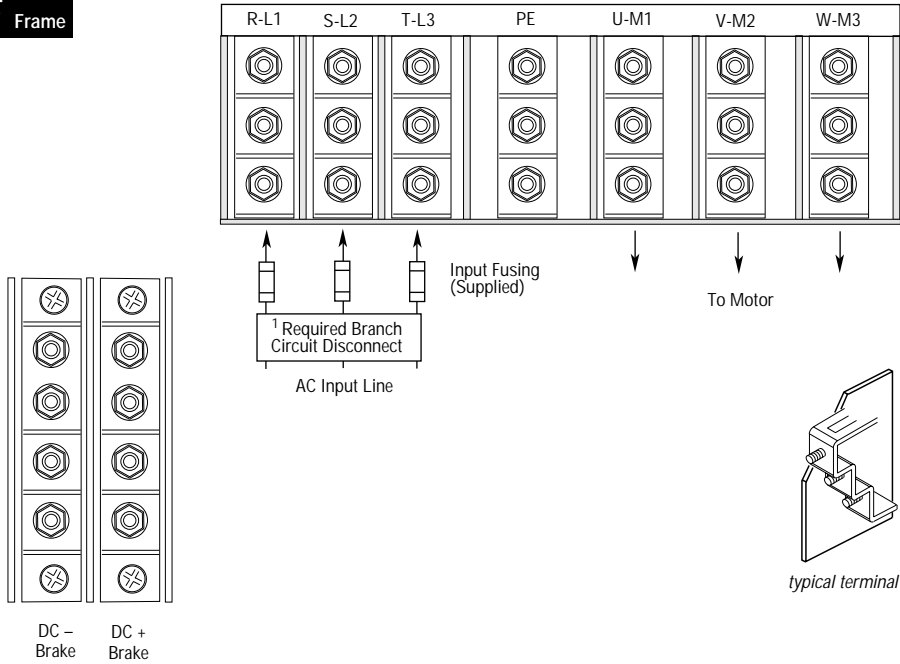
E Frame



¹ User supplied.

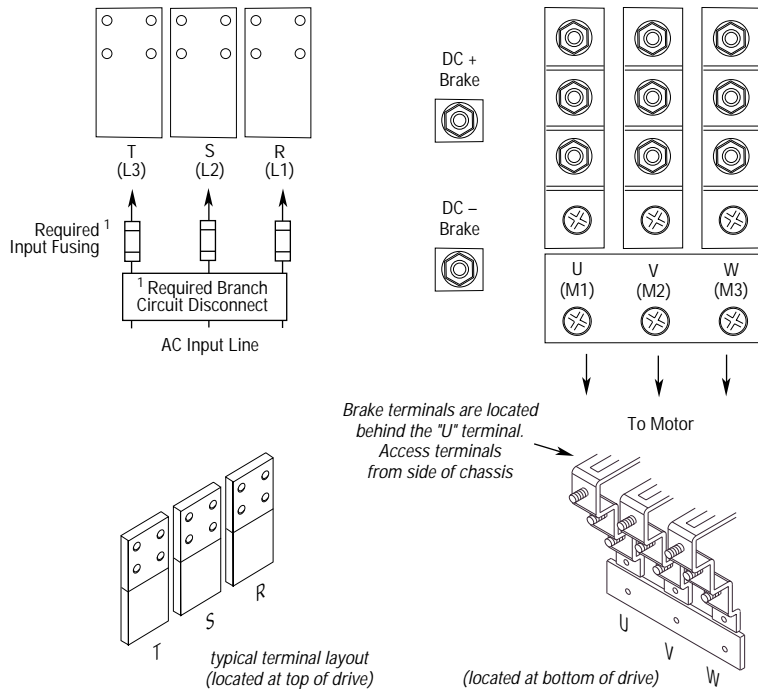
380-480V, 187-336 kW (250-450 HP) Terminal Designations

F Frame



380-480V, 224-448 kW (300-600 HP) Terminal Designations
 500-600V, 187-448 kW (250-600 HP) Terminal Designations

G Frame



¹ User supplied.

Control and Signal Wiring

Terminal Block TB2

TB2 is located at the bottom of the Main Control Board. 0.37-7.5 kW (0.5-10 HP) A Frame drives have 18 positions. Remaining frame sizes from 5.5 kW (7.5 HP) and up have 22 positions. The maximum and minimum wire size accepted by TB2 is 2.1 and 0.30 mm² (14 and 22 AWG). Maximum torque for all terminals is 1.36 N-m (12 lb.-in.). Use Copper wire only. See Figures 2.1 and 2.3.

The recommended control signal wire is:

- Belden 8760 (or equiv.)–0.750 mm² (18 AWG), twisted pair, shielded.
- Belden 8770 (or equiv.)–0.750 mm² (18 AWG), 3 conductor, shielded.
- Belden 9460 (or equiv.)–0.750 mm² (18 AWG), twisted pair, shielded.

Control Connections

If the drive control connections are to be linked to an electronic circuit or device, the common or 0V line should, if possible, be grounded at the device (source) end only.

Important: Signal Common – User speed reference signals are terminated to logic common at TB2, terminal 3 or 4. This puts the negative (or common) side of these signals at earth ground potential. Control schemes must be examined for possible conflicts with this type of grounding scheme.

Shield Termination – TE (True Earth)

The TE terminal block (not available on 0.37-7.5 kW (0.5-10 HP) A Frame drives) provides a terminating point for signal wiring shields. Refer to Figures 2.1 and 2.3 for location.

The maximum and minimum wire size accepted by this block is 2.1 and 0.30 mm² (14 and 22 AWG). Maximum torque is 1.36 N-m (12 lb.-in.). Use Copper wire Only and always separate control and power cabling.

Cable Routing

If unshielded cable is used, control signal circuits should not run parallel to motor cables or unfiltered supply cables with a spacing less than 0.3 meters (1 foot). Cable tray metal dividers or separate conduit should be used.

Important: When user installed control and signal wiring with an insulation rating of less than 600V is used, this wiring must be routed inside the drive enclosure such that it is separated from any other wiring and uninsulated live parts.

Figure 2.3
TB2 Connections

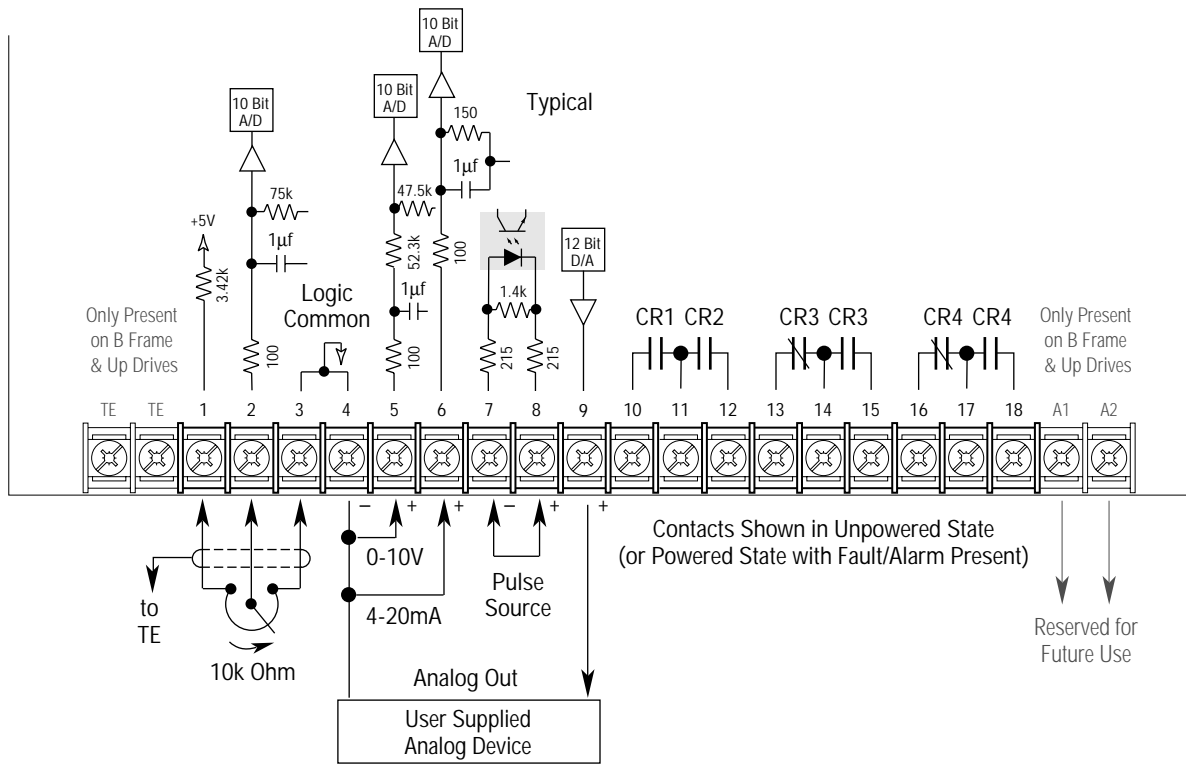


Table 2.G
Terminal Block TB2 Specifications

Terminal	Signal	
TE	True Earth – Shield Termination	
1, 2, 3	External Speed Pot. or Analog Trim Pot. (10k ohm pot. required) ²	
4	Signal Common	
5	0-10V DC Input ²	Input Impedance = 100k ohms
6	4-20mA Input ²	Input Impedance = 250 ohms
7, 8	Pulse Input for Frequency Ref. ⁴	Refer to <i>Pulse Input</i> on the following page
9	Analog Output ¹ A Frame Drives	Jumper JP1 to select 0-10V DC output ⁵ Jumper JP2 to select 0-20mA output ⁶
	Analog Output ¹ B Frame Drives and Up	Jumper J5 selects output pins 1-2 = 0-20mA ⁶ pins 3-4 = 0-10V DC ⁵
10, 11	CR1 Programmable Contact	Resistive Rating = 115V AC/30V DC, 5.0A Inductive Rating = 115V AC/30V DC, 2.0A
11, 12	CR2 Programmable Contact <i>Firmware Versions 4.01 & Up</i>	
	CR2 Run Contact <i>Firmware Versions below 4.01</i>	
13, 14 14, 15	CR3 Programmable Contact <i>Firmware Versions 4.01 & Up</i>	
	CR3 Fault & Fault NOT Contact ³ <i>Firmware Versions below 4.01</i>	
16, 17 17, 18	CR4 Programmable Contact <i>Firmware Versions 4.01 & Up</i>	
	CR4 Alarm & Alarm NOT Contact <i>Firmware Versions below 4.01</i>	
A1, A2	Reserved for Future Use	

efesotomasyon.com

¹ Refer to the I/O Config group parameters for analog scaling.
² Refer to the [Maximum Speed] parameter on page 5-45.
³ Refer to Chapter 6 for contact description.
⁴ Not available if Encoder Feedback option is used.
⁵ Minimum Load Impedance:
 A Frame drives = 3.5k ohms
 B Frame drives & Up = 1.5k ohms.
 Recommended load for all frames = 10k ohms.
⁶ Maximum Load Impedance:
 A Frame drives = 260 ohms
 B Frame drives & Up = 315 ohms

Pulse Input



ATTENTION: If reverse polarity or voltage levels are maintained above +12V DC, signals may be degraded and component damage may result.

The pulse input signal must be an externally powered square-wave pulse at a 5V TTL logic level. Circuits in the high state must generate a voltage between 4.0 and 5.5V DC at 16 mA. Circuits in the low state must generate a voltage between 0.0 and 0.4V DC. Maximum input frequency is 125kHz. Scale factor [Pulse/Enc Scale] must be set.

Important: Pulse inputs (TB2-7, 8) cannot be used if encoder inputs (TB3, terminals 31-36) are being used.

Control Interface Option – TB3

The Control Interface Option provides a means of interfacing various signals and commands to the 1336 PLUS by using contact closures. Six different versions of the option are available:

- L4 Contact Closure Interface ¹
- L4E Contact Closure Interface ¹ with Encoder Feedback Inputs
- L5 +24V AC/DC Interface
- L5E +24V AC/DC Interface with Encoder Feedback Inputs
- L6 115V AC Interface
- L6E 115V AC Interface with Encoder Feedback Inputs

¹ Uses internal +5V DC supply.

The user inputs are connected to the option board through TB3 (see Figure 2.1 for location). The L4, L5 and L6 options each have nine control inputs. The function of each input must be selected through programming as explained later in this section. The L4E, L5E and L6E options are similar to L4, L5 and L6 with the addition of encoder feedback inputs. Refer to Figure 2.6 (a, b & c) for input impedance values.

Available Inputs

A variety of combinations made up of the following inputs are available.

Input	Description
1 st /2 nd Accel/Decel	These inputs allow selection of the accel or decel time used by the drive.
Auxiliary	Required for Operation – this input is intended to fault the drive via external devices (i.e. motor thermoswitch, O.L. relays, etc.). Opening this contact will fault (F02 – Aux Fault) the drive and shut the output off, ignoring the programmed stop mode.
Digital Pot Up/Down	These inputs increase (up) or decrease (down) the drive commanded frequency when MOP (Motor Operated Potentiometer) is chosen as the frequency command source. The rate of increase/decrease is programmable.
Enable	Required for Operation – opening this input shuts the drive output off, ignoring the programmed stop mode.
Integrator Reset (NOT)	Opening this input clamps the process PI integrator value at zero. Closing this input allows the integrator to continue to operate.
Local Control	Closing this input gives exclusive control of drive logic to the inputs at terminal block TB3. No other devices may issue logic commands (excluding Stop) to the drive.
PI Output	Enables or disables the output of the PI regulator.
Reverse	Available Only with three-wire control – In single source reversing modes, closing this input commands reverse direction and opening this input commands forward direction.
Reverse or Forward	In multi-source reversing modes, closing these inputs commands the corresponding direction. If both inputs are open or both are closed, the current direction is maintained.
Run Forward/Reverse	Available Only with two-wire control – Closing these inputs issues both a start command and a direction command to the drive. Opening these contacts issues a stop command to the drive.
Speed Select 1, 2, 3	These inputs choose the frequency command source for the drive. See following pages for details.
Start	Issues a Start command for the drive to begin acceleration to commanded frequency.
Stop Type	Closing this input selects the stop mode in [Stop Select 2] as the method of stopping when a stop command is issued. Opening this input selects the stop mode in [Stop Select 1] as the method of stopping.
Stop/Fault Reset	Issues a Stop command for the drive to cease output per the programmed stop mode. If the drive has faulted, opening this input resets the fault if [Fault Clear Mode] is enabled.

The available combinations are shown in Figure 2.5. Programming the [Input Mode] parameter to one of the Input Mode numbers listed, will select that combination of input functions.

Important: If a Control Interface Option is not installed, the [Input Mode] parameter must be set to 1 (default) and jumpers must be installed as shown in Figure 2.7. If the drive was shipped from the factory without the option, these jumpers will have been installed.

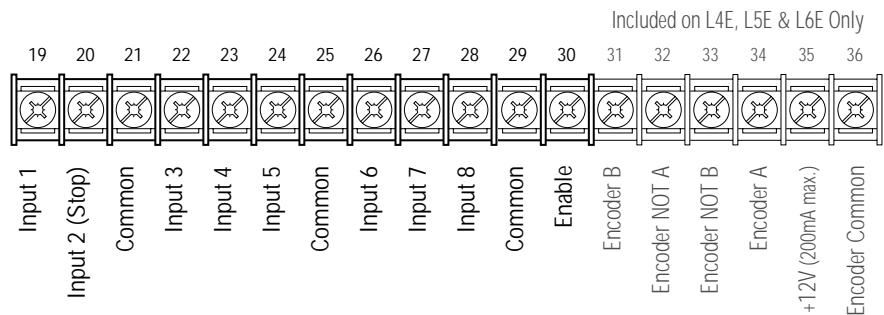
Important: The [Input Mode] parameter can be changed at any time, but the change will not affect drive operation until power to the drive has been removed and bus voltage has decayed completely. When changing the [Input Mode] parameter, it is important to note that the functions of the TB3 inputs will change when power is reapplied to the drive.

The programming options of the Control Interface Option allow the user to select an input combination to meet the needs of a specific installation. Appropriate selection of a combination may be done by using Figure 2.5. First determine the type of start/stop/direction control desired. Then select the remaining control functions available. Record the selected mode number below.

Selected Mode Number: _____

Figure 2.4 provides the terminal designations for TB3. The maximum and minimum wire size accepted by TB3 is 2.1 and 0.30 mm² (14 and 22 AWG). Recommended torque for all terminals is 0.90-1.13 N-m (8-10 lb.-in.). See Figure 2.6 for TB3 interconnection information. Use Copper wire only.

Figure 2.4
TB3 Terminal Designations



Speed Select/Frequency Reference

The drive speed command can be obtained from a number of different sources. The source is determined by drive programming and the condition of the Speed Select Inputs on TB3 (or reference select bits of command word if PLC controlled – see Appendix A).

The default source for a command reference (all speed select inputs open) is the selection programmed in [Freq Select 1]. If any of the speed select inputs are closed, the drive will use other parameters as the speed command source. Refer to Table 2.H and the examples that follow.

Table 2.H
Speed Select Input State vs. Frequency Source

Speed Select 3	Speed Select 2	Speed Select 1	Frequency Source
Open	Open	Open	[Freq Select 1]
Open	Open	Closed	[Freq Select 2]
Accessed through [Freq Select 2] parameter			[Preset Freq 1]
Open	Closed	Open	[Preset Freq 2]
Open	Closed	Closed	[Preset Freq 3]
Closed	Open	Open	[Preset Freq 4]
Closed	Open	Closed	[Preset Freq 5]
Closed	Closed	Open	[Preset Freq 6]
Closed	Closed	Closed	[Preset Freq 7]

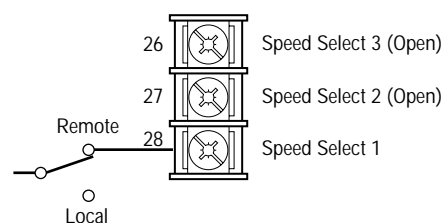
Important: The final speed command may be affected by the type of modulation selected with [Speed Control], parameter 77. Refer to [Speed Control] in Chapter 5 for further information.

Example 1

Input Mode 2 – Application calls for a local Human Interface Module (HIM) speed command or remote 4-20mA from a PLC. The drive is programmed as follows:

- [Freq Select 1] = Adapter 1
- [Freq Select 2] = 4-20mA

With Speed Select inputs 2 & 3 open and the selector switch set to “Remote” (Speed Select 1 closed), the drive will follow [Freq Select 2] or 4-20mA. With the switch set to “Local” (Speed Select 1 open) all speed select inputs are open and the drive will follow the local HIM (Adapter 1) as selected with [Freq Select 1].

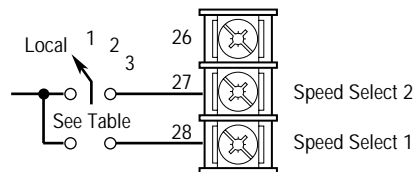


Example 2

Input Mode 7 – Application is to follow a local HIM unless a preset speed is selected. The drive is programmed as follows:

- [Freq Select 1] = Adapter 1
- [Freq Select 2] = Preset Freq 1
- [Preset Freq 1] = 10 Hz.
- [Preset Freq 2] = 20 Hz.
- [Preset Freq 3] = 30 Hz.

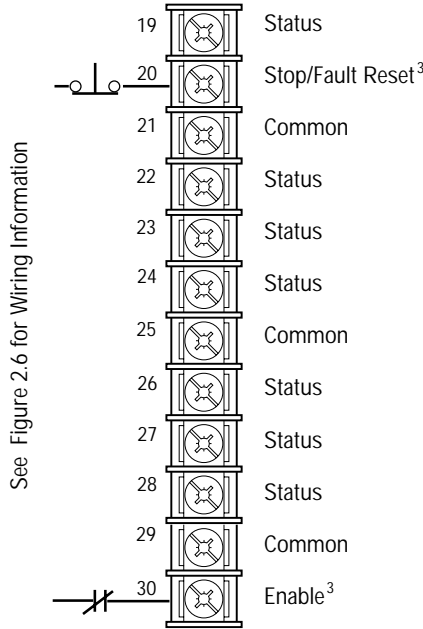
Contact operation for the speed select switch is described in the table below. Since Input Mode 7 does not offer a Speed Select 3 input, [Preset Freq 4-7] are not available.



Switch Position	Speed Select Input		Parameter Used for Speed Ref.	Programmed Setting
	1 (#28)	2 (#27)		
Local	Open	Open	[Freq Select 1]	Adapter 1
1	Closed	Open	[Freq Select 2]	Preset Freq 1
2	Open	Closed	[Preset Freq 2]	20 Hz.
3	Closed	Closed	[Preset Freq 3]	30 Hz.

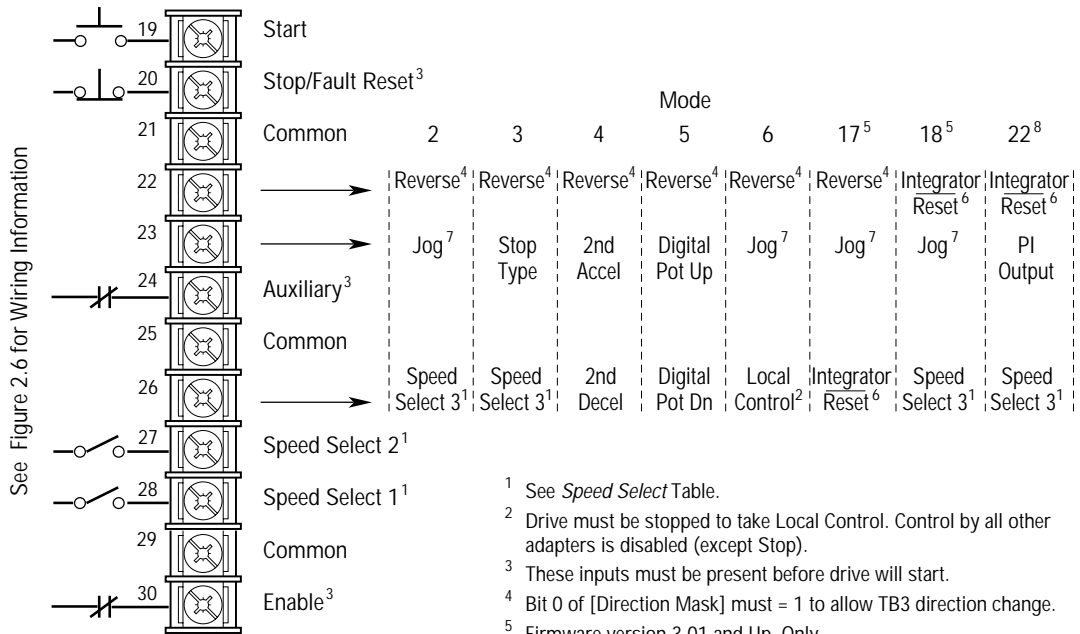
Figure 2.5
Input Mode Selection & Typical TB3 Connections

[Input Mode] 1
Factory Default



Note: If this mode is selected, the status of all inputs can be read at the [Input Status] parameter. However, only "Stop/Fault Reset" and "Enable" will have control function.

[Input Mode] 2-6, 17, 18, 22
Three-Wire Control with Single-Source Reversing



¹ See *Speed Select* Table.
² Drive must be stopped to take Local Control. Control by all other adapters is disabled (except Stop).
³ These inputs must be present before drive will start.
⁴ Bit 0 of [Direction Mask] must = 1 to allow TB3 direction change.
⁵ Firmware version 3.01 and Up, Only.
⁶ Inverted function – voltage resets integrator to zero.
⁷ See ATTENTION statement on this page.
⁸ Firmware version 4.01 and Up, Only.

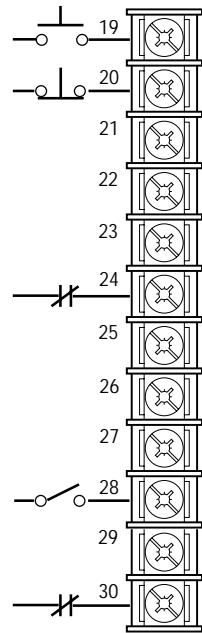
ATTENTION: The JOG function will not operate properly unless a SCANport option is connected to the drive. To assure proper JOG function, install at least one of the following: 1201-HAP, 1201-HA1, 1201-HA2, 1336-GM1. Applies to 1305 with firmware FRN 2.01 or earlier and 1336 PLUS with Language Module 1336S-EN firmware FRN 1.05 or earlier.



ATTENTION: The JOG function will not operate properly unless a SCANport option is connected to the drive. To assure proper JOG function, install at least one of the following: 1201-HAP, 1201-HA1, 1201-HA2, 1336-GMI. Applies to 1305 with firmware FRN 2.01 or earlier and 1336 PLUS with Language Module 1336S-EN firmware FRN 1.05 or earlier.



See Figure 2.6 for Wiring Information

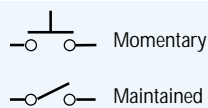


[Input Mode] 7-11, 19, 23
Three-Wire Control with Multi-Source Reversing

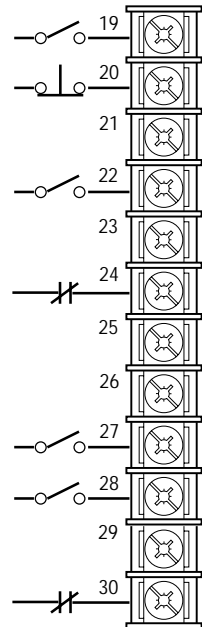
Mode	7	8	9	10	11	19 ⁵	23 ⁸
Reverse ⁴	Reverse ⁴	Reverse ⁴	Digital Pot Up	Reverse ⁴	1st Accel	Reverse ⁴	Reverse ⁴
Forward ⁴	Forward ⁴	Forward ⁴	Digital Pot Dn	Forward ⁴	2nd Accel	Forward ⁴	Forward ⁴
Jog ⁷	Jog ⁷	Speed Select 3 ¹	Speed Select 3 ¹	Digital Pot Up	1st Decel	Integrator Reset ⁶	Integrator Reset ⁶
Speed Select 2 ¹	Speed Select 2 ¹	Speed Select 2 ¹	Speed Select 2 ¹	Digital Pot Dn	2nd Decel	Speed Select 2 ¹	PI Output

[Input Mode] 12-16, 20, 21, 24
Two-Wire Control, Single-Source Control

See ATTENTION statement below



See Figure 2.6 for Wiring Information



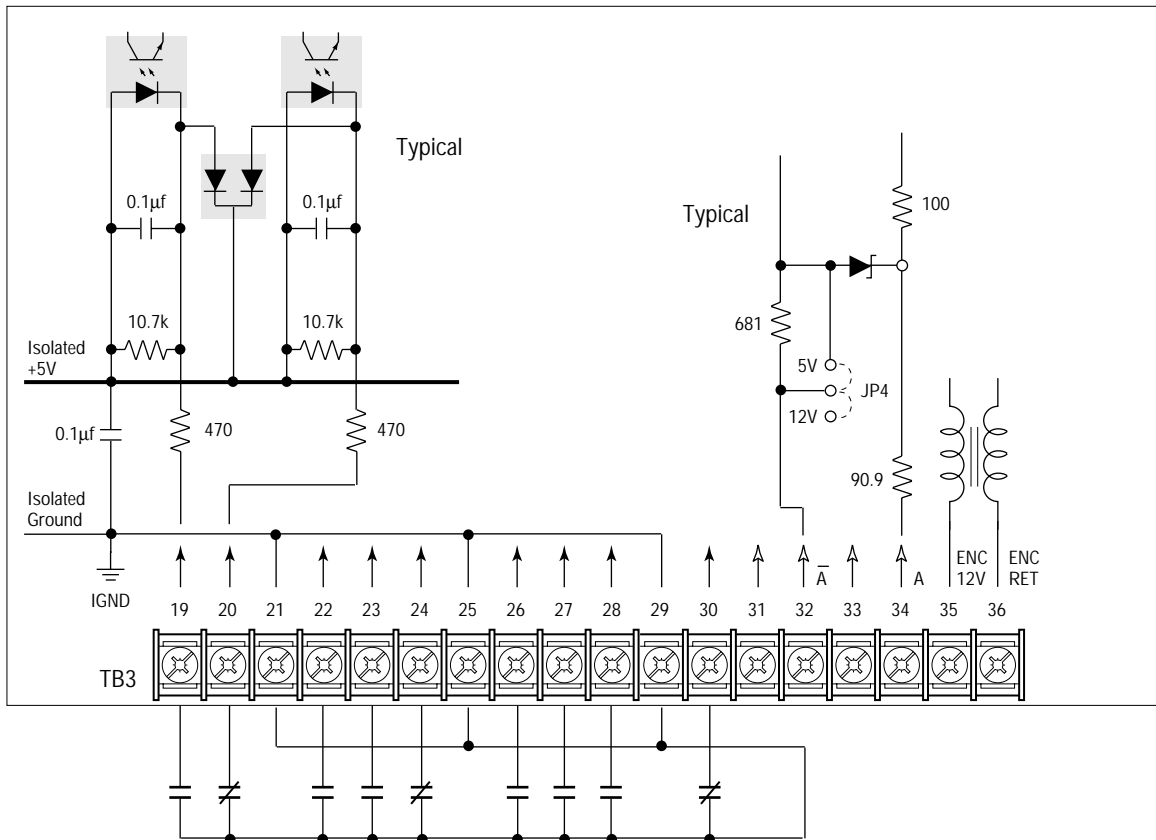
Mode	12	13	14	15	16	20 ⁵	21 ⁸	24 ⁸
Local Control ²	Local Control ²	Stop Type	2nd Accel	Digital Pot Up	Local Control ²	Local Control ²	Jog ⁷	PI Output
Speed Select 3 ¹	Speed Select 3 ¹	Speed Select 3 ¹	2nd Decel	Digital Pot Dn	Stop Type	Integrator Reset ⁶	Speed Select 3 ¹	Integrator Reset ⁶



Two wire control uses maintained Run contacts that act as both Run (closed) and Stop (open) devices. Opening the Stop contact (terminal 20) will stop the drive. If this contact is reclosed, any fault will be reset. If a valid Start command is still present, the drive will restart.

If a three wire device (i.e. HIM) is also used, pressing the HIM Stop key will also stop the drive. Releasing the Stop key will clear any faults that are present, but the drive will not restart without cycling the Start contact.

Figure 2.6 a
Option L4/L4E Wiring



Contacts shown are general, refer to Figure 2.5 for Input Mode selection and recommended contact types.

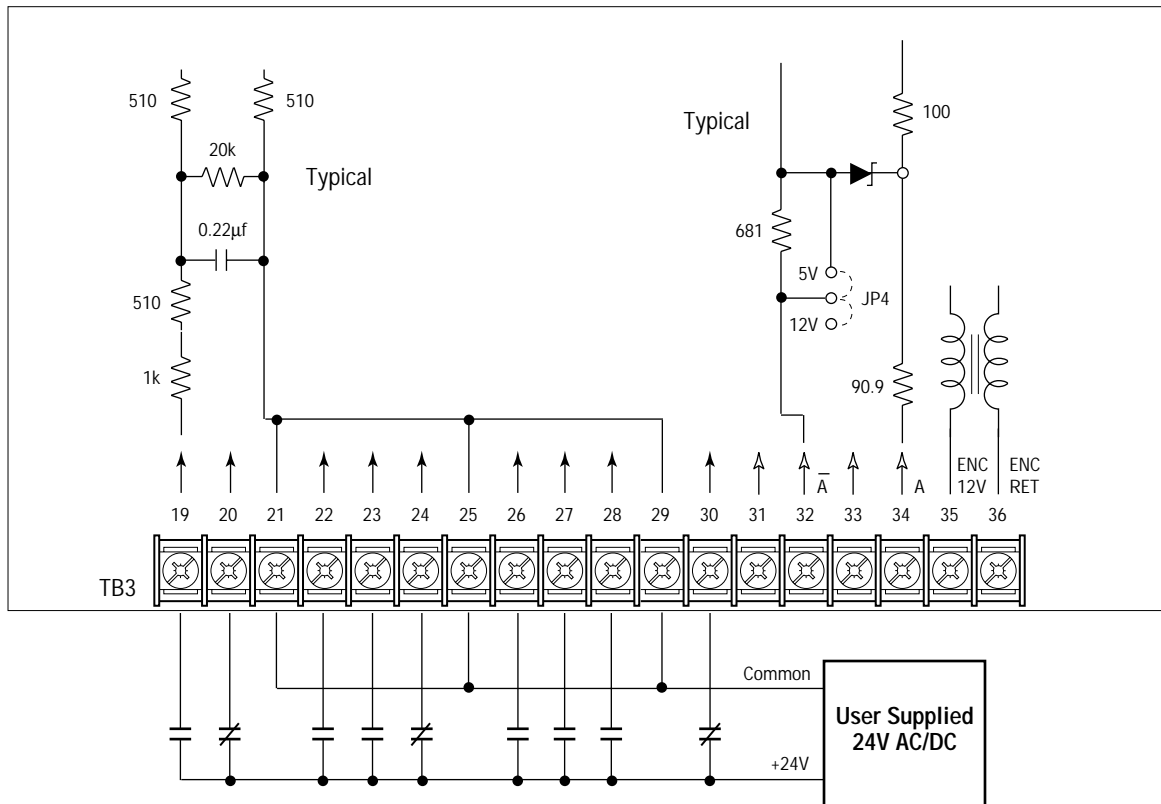
Option L4/L4E – Contact Closure Interface Board Requirements

Contacts must be capable of operating at 10 mA current levels without signal degradation. Reed type input devices are recommended.

The L4/L4E option is compatible with the following Allen-Bradley PLC[®] modules:

- 1771-OYL
- 1771-OZL

Figure 2.6 b
Option L5/L5E Wiring



Contacts shown are general, refer to Figure 2.5 for Input Mode selection and recommended contact types.

Option L5/L5E – 24V AC/DC Interface Board Requirements

Circuits used with Option L5/L5E must be capable of operating with high = true logic.

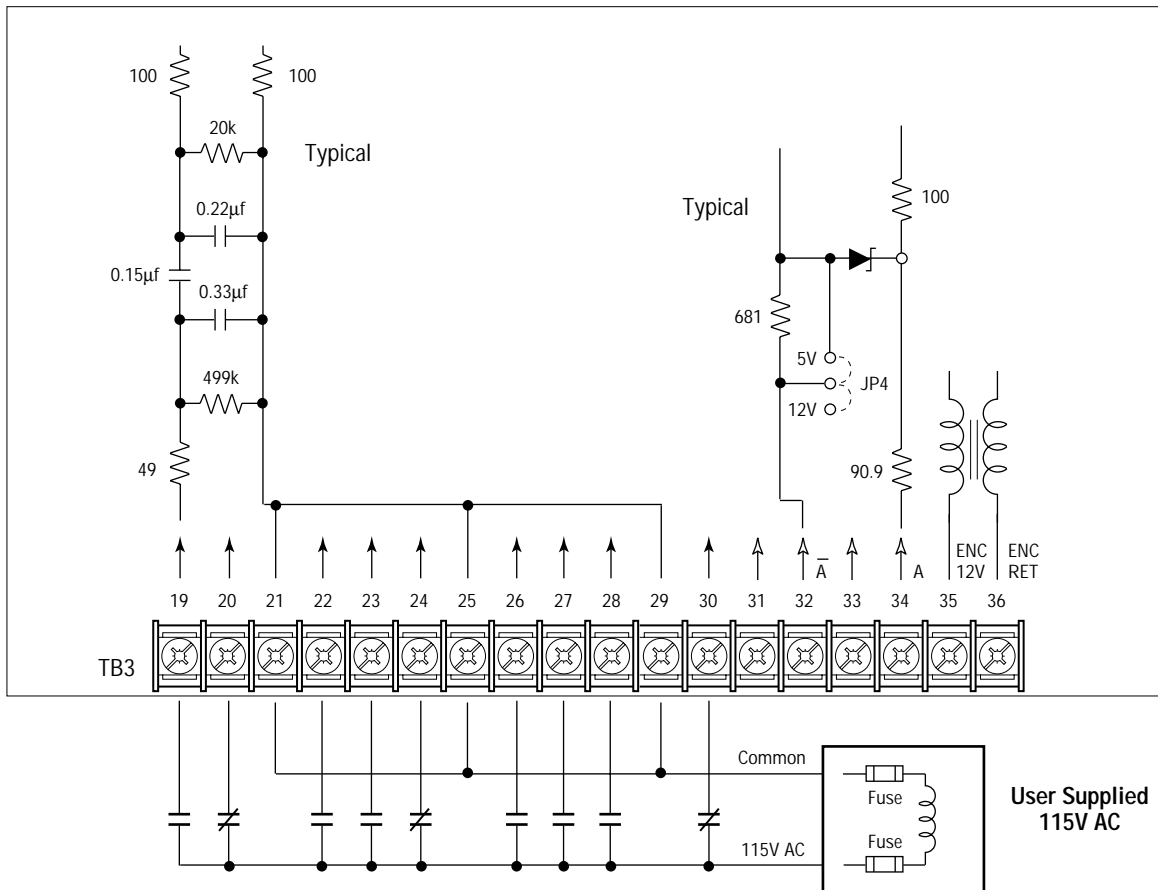
DC external circuits in the low state must generate a voltage of no more than 8V DC. Leakage current must be less than 1.5 mA into a 2.5k ohm load.

AC external circuits in the low state must generate a voltage of no more than 10V AC. Leakage current must be less than 2.5 mA into a 2.5k ohm load.

Both AC and DC external circuits in the high state must generate a voltage of +20 to +26 volts and source a current of approximately 10 mA for each input. The L5/L5E option is compatible with these Allen-Bradley PLC modules:

- 1771-OB
- 1771-OBD
- 1771-OBN
- 1771-OQ
- 1771-OQ16
- 1771-OYL
- 1771-OZL
- 1771-OB16
- 1771-OB16
- 1771-OB16
- 1771-OB16

Figure 2.6 c
Option L6/L6E Wiring



Contacts shown are general, refer to Figure 2.5 for Input Mode selection and recommended contact types.

Option L6/L6E – 115V AC Interface Board Requirements

Circuits used with Option L6/L6E must be capable of operating with high = true logic. In the low state, circuits must generate a voltage of no more than 30V AC. Leakage current must be less than 10 mA into a 6.5k ohm load. In the high state, circuits must generate a voltage of 90-115V AC $\pm 10\%$ and source a current of approximately 20 mA for each input. The L6/L6E option is compatible with these Allen-Bradley PLC modules:

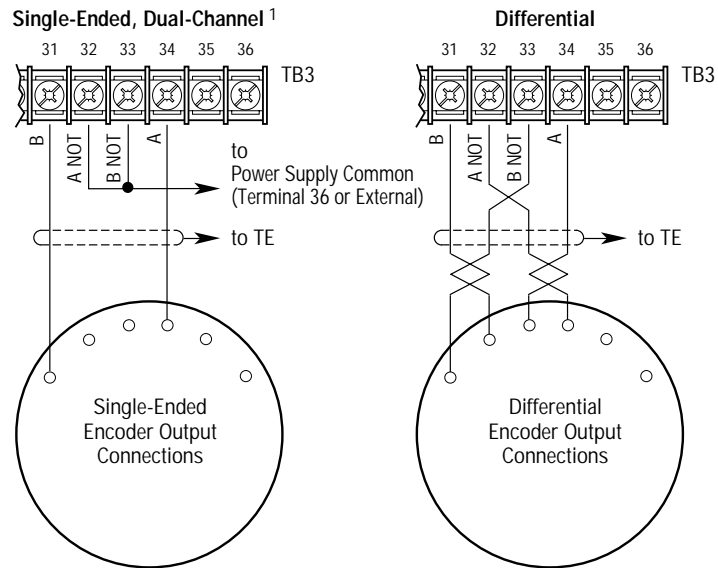
- 1771-OW
- 1771-OA
- 1771-OWN
- 1771-OAD

Encoder Wiring

Encoders must be line driver type, quadrature or pulse, 5V DC or 8-15V DC output, single-ended or differential and capable of supplying a minimum of 10mA per channel. Maximum input frequency is 125 kHz. Encoder inputs (TB3, terminals 31-36) cannot be used if Pulse Train inputs (TB2-7, 8) are being used.

The interface board is jumper selectable to accept a 5V TTL or 12V DC square-wave with a minimum high state voltage of 3.0V DC (TTL) or 7.0V DC (12 volt encoder). Maximum low state voltage is 0.4V DC. Recommended wire – shielded, 0.750 mm² (18 AWG), 305 m (1000 ft.) or less. Maximum input frequency is 125kHz. See *Encoder & Communications Cabling* on page 2-9.

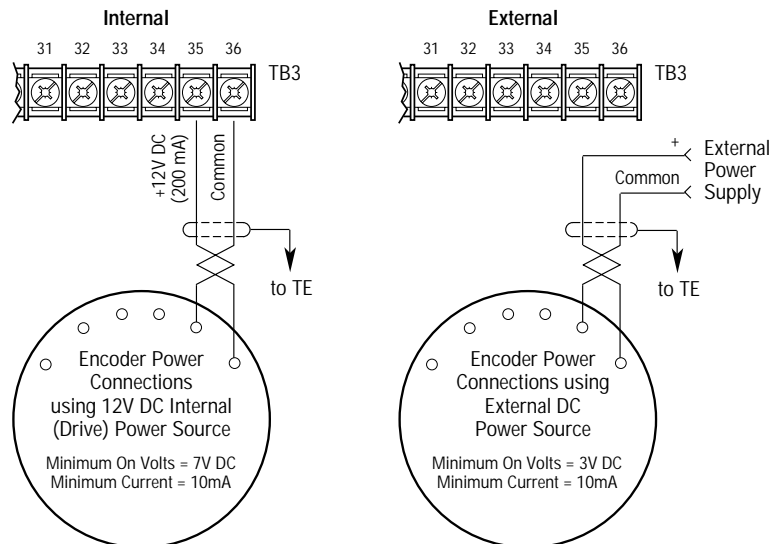
Figure 2.6 d
Encoder Signal Wiring



¹ For Single-Ended, Single-Channel (pulse) applications, eliminate the B and B (NOT) connections. Some encoders may label the "A" connection as "Signal."

Important: Correct direction of motor rotation as determined during start-up (see Chapter 4) may require that the A or B channel wiring be reversed.

Figure 2.6 e
Encoder Power Wiring



Important: Control Interface Board jumpers JP3 & JP4 must be set for the voltage level of the encoder output.

Output Devices

Drive Output Disconnection



ATTENTION: Any disconnecting means wired to the drive output terminals U, V and W must be capable of disabling the drive if opened during drive operation. If opened during drive operation, the drive will continue to produce output voltage between U, V, W. An auxiliary contact must be used to simultaneously disable the drive.

Common Mode Cores

Common Mode Cores will help reduce the common mode noise at the drive output and guard against interference with other electrical equipment (programmable controllers, sensors, analog circuits, etc.). In addition, reducing the PWM carrier frequency will reduce the effects and lower the risk of common mode noise interference. Refer to the table below.

Table 2.1
1336 PLUS Common Mode Chokes

Catalog Number	Used with . . .	Description
1321-M001	Communications Cables, Analog Signal Cables, etc.	Open Style - Signal Level
1321-M009	All 1336 PLUS Drives Rated: 480V, 0.37-3.7 kW (0.5-5 HP)	Open Style with Terminal Block, 9A
1321-M048	All 1336 PLUS Drives Rated: 480V, 5.5-22 kW (7.5-30 HP) 600V, 5.5-30 kW (7.5-40 HP)	Open Style, 48A
1321-M180	All 1336 PLUS Drives Rated: 480V, 30-112 kW (40-X150 HP) 600V, 37-93 kW (50-125 HP)	Open Style, 180A
1321-M670	All 1336 PLUS Drives Rated: 480V, 112-448 kW (150-600 HP) 600V, 149-448 kW (200-600 HP)	Open Style, 670A

Cable Termination

Optional Cable Terminator

Voltage doubling at motor terminals, known as reflected wave phenomenon, standing wave or transmission line effect, can occur when using drives with long motor cables.

Inverter duty motors with phase-to-phase insulation ratings of 1200 volts or higher should be used to minimize effects of reflected wave on motor insulation life.

Applications with non-inverter duty motors or any motor with exceptionally long leads may require an output filter or cable terminator. A filter or terminator will help limit reflection to the motor, to levels which are less than the motor insulation rating.

Table 2.E lists the maximum recommended cable length for unterminated cables, since the voltage doubling phenomenon occurs at different lengths for different drive ratings. If your installation requires longer motor cable lengths, a reactor or cable terminator is recommended. Refer to Table 2.E for frequency, cable length and voltage restrictions of 1204-TFA1 or 1204-TFB2 terminators.

Optional Output Reactor

Bulletin 1321 Reactors listed in the 1336 PLUS-3.0 Price Sheet can be used for drive input and output. These reactors are specifically constructed to accommodate IGBT inverter applications with switching frequencies up to 20 kHz. They have a UL approved dielectric strength of 4000 volts, opposed to a normal rating of 2500 volts. The first two and last two turns of each coil are triple insulated to guard against insulation breakdown resulting from high dv/dt. When using motor line reactors, it is recommended that the drive PWM frequency be set to its lowest value to minimize losses in the reactors.

Important: By using an output reactor the effective motor voltage will be lower because of the voltage drop across the reactor – this may also mean a reduction of motor torque.

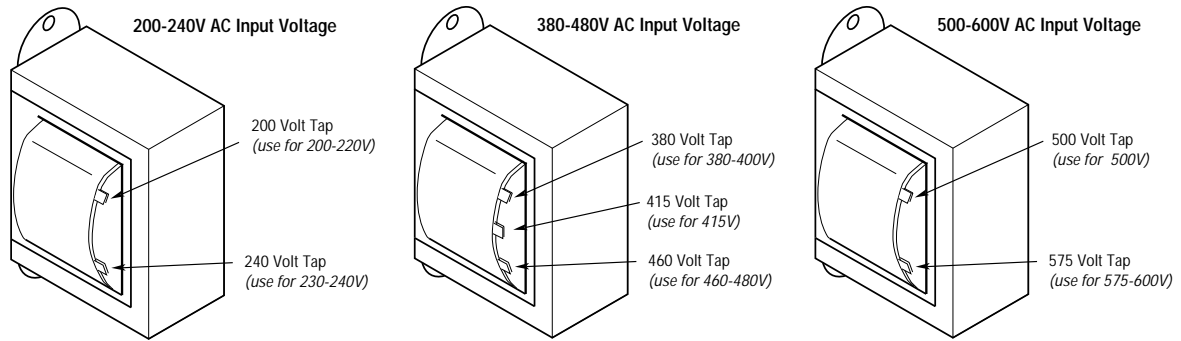
Selecting/Verifying Fan Voltage

1336 PLUS drives, 45 kW (60 HP) and up that have cooling fans utilize a transformer to match the input line voltage to the proper fan voltage. If an input voltage other than the standard 240, 480 or 600V AC is used, the transformer tap may have to be changed.



ATTENTION: To avoid a shock hazard, assure that all power to the drive has been removed before proceeding.

1. Ensure that all power has been removed to the drive.
2. Locate the transformer in the lower left corner of the drive chassis. Note lead placement (tap being used).
3. Determine the correct tap from the following figure and verify.
4. If present tap is incorrect, remove the insulating sleeve from the correct tap.
5. Remove the wire lead presently connected and place on the selected tap. Replace the insulating sleeve on the unused tap.



Auxiliary Inputs – TB4, TB6

Terminal blocks TB4 and TB6 (B Frame drives & up) allow the drive power supplies to be operated from an external voltage source. Both terminal blocks are located on the Base Driver Board and are accessible from the front of the drive. See Figure 2.1 for locations.

TB4 can be used to externally power the low voltage power supply, allowing operation of drive control functions in the absence of bus voltage. Applying proper voltage to TB4 (see Table 2.J) provides +5V, $\pm 15V$ and isolated 12V outputs for:

- Main Control Board (Control Interface Boards, RIO Board, etc.)
- SCANport™ (HIM, etc.)
- Encoder(s)
- ELMS
- Precharge
- Any DC fans in the drive

TB6 can be used to externally power the high voltage power supply which provides inverter IGBT drive voltage and the low voltage necessary to power the low voltage power supply. This allows operation of the drive in the absence of bus voltage.

The maximum and minimum wire size accepted by TB4 is 2.1 and 0.06 mm² (14 and 30 AWG). Wire sizes for TB6 are 5.3 and 0.06 mm² (10 and 30 AWG). Use Copper wire Only with a minimum temperature rating of 75° C. Maximum torque for both terminal blocks is 0.57 N-m (5 lb.-in.).

Table 2.J
Power Supply Input Requirements¹

Terminal Block	Drive Type	Input Voltage	Average Current	Peak Current
TB4	All	22-28V DC ²	2.25A	5.00A
TB6	230V AC	200-375V DC ³	0.50A	1.00A
	380-480V AC	400-750V DC ³	0.25A	0.50A
	500-600V AC	400-925V DC ³	0.25A	0.50A

¹ The power source used to drive a power supply must be capable of providing the peak current at startup. A "flat" current or power limit is acceptable, but a foldback current limit may trip at startup, never allowing the supply to start.

² Must be supplied from a Class 2 Limited Power Source.

³ Must be supplied from a source that is provided with transient voltage surge suppression such that transients are suppressed to 6000V peak maximum or less.

Auxiliary Output – TB9

The 480 or 600V (depending on input voltage to drive) output terminal block (TB9) is only available on F Frame Drives. This terminal block provides a three-phase, high voltage connection from the load side of the AC input line fuses. Normally this connection is used to power an external control transformer (user supplied) or other auxiliary circuit. Refer to Figure 2.1 for location.

Important: Depending on the circuitry connected, additional fusing may be required.



ATTENTION: The installation of auxiliary circuits must comply with the national codes and standards (NEC, VDE, BSA, etc.) and local codes regarding wire type, conductor sizes, branch circuit protection and disconnect devices. Failure to do so may result in personal injury and/or equipment damage.

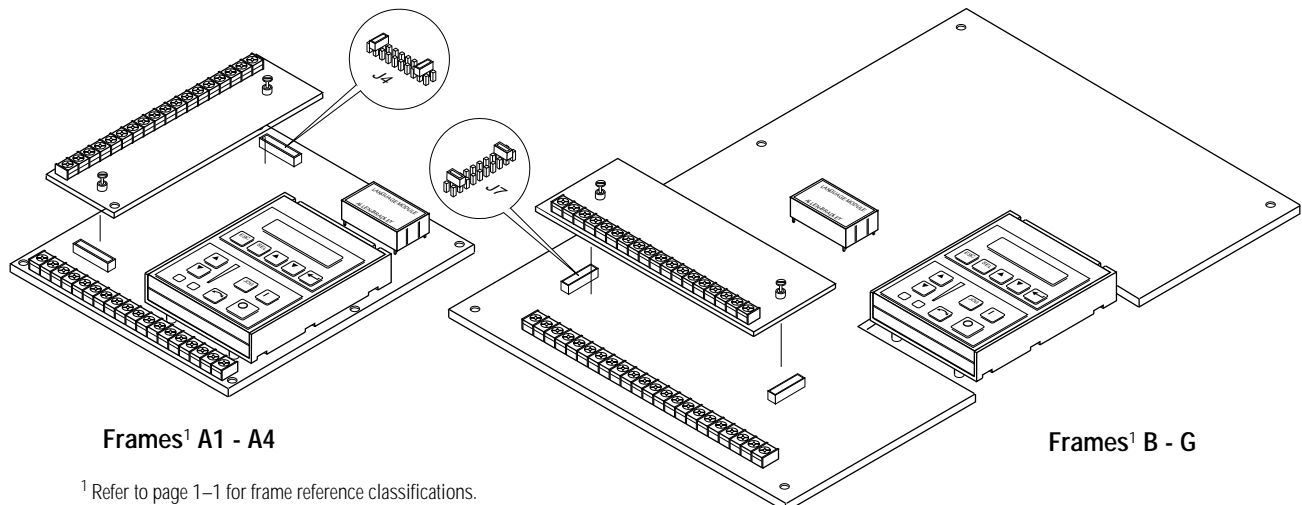
The auxiliary circuit can be utilized to a maximum current capacity of 8 amperes RMS.

The maximum and minimum wire size accepted by TB9 is 4.0 and 0.8 mm² (12 and 18 AWG). Use Copper wire Only with a minimum temperature rating of 75° C. Maximum torque is 0.90-1.81 N-m (8-16 lb.-in.).

Interface Board Installation and Removal

Important: If the Control Interface Board is being installed, Main Control Board jumpers at pins 3 & 4 and 17 & 18 of J4 (J7 on B Frame & up drives) must be removed and the proper [Input Mode] selected. If this board is removed, these jumpers must be reinstalled and the [Input Mode] parameter must be programmed to “1.”

Figure 2.7
Jumper Locations

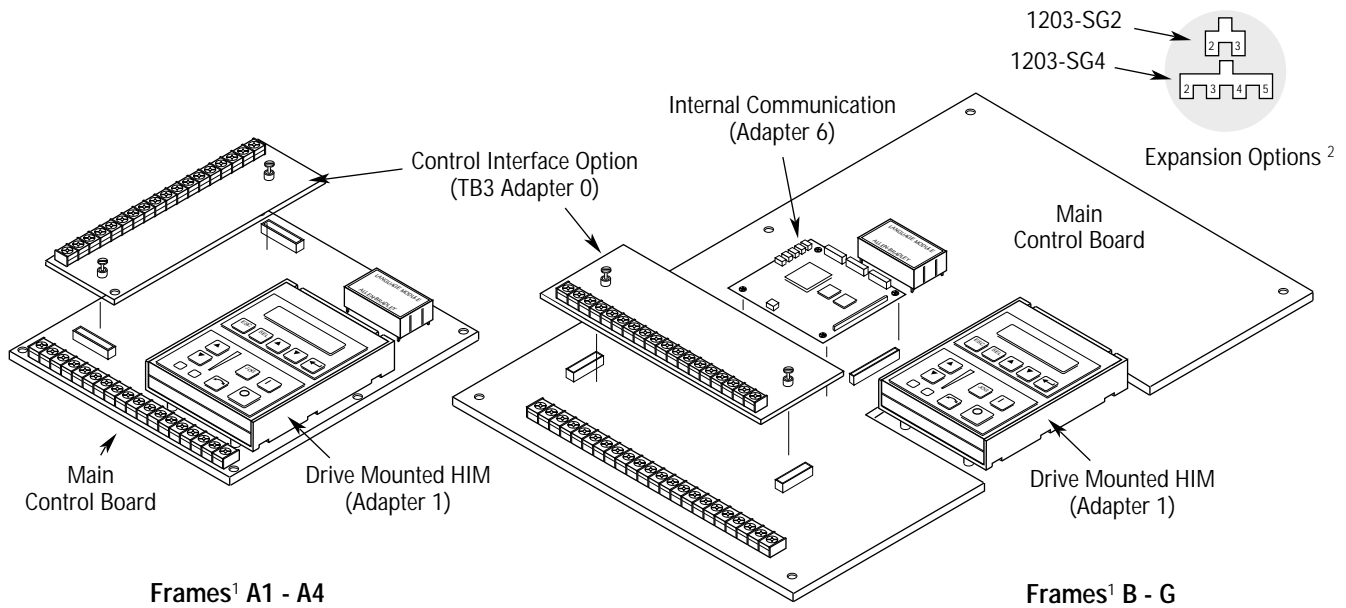


¹ Refer to page 1-1 for frame reference classifications.

Adapter Definitions

Serial communication devices such as the Human Interface Module that are connected to the drive are identified by SCANport serial communications as Adapters. Depending on the drive and options ordered, a number of different adapters are available as shown in Figure 2.8. Figure 2.9 shows the maximum distance allowed between devices.

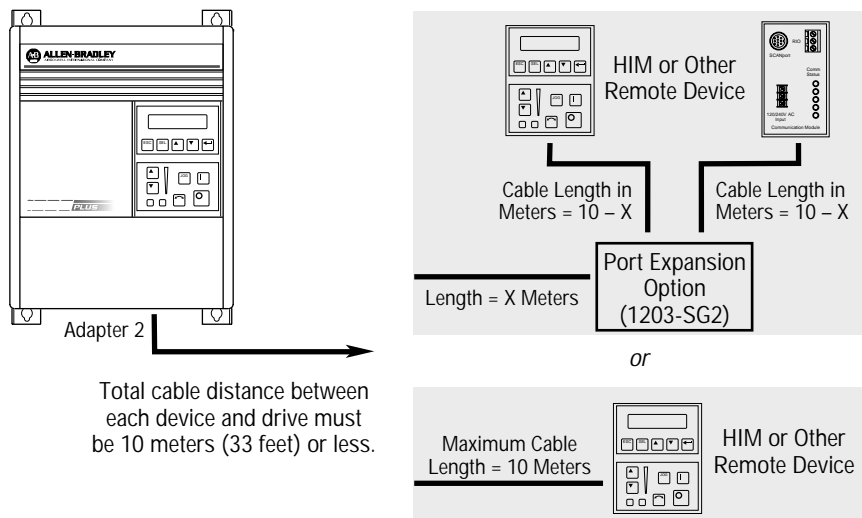
Figure 2.8
Adapter Locations



¹ Refer to page 1-1 for frame reference classifications.

² Communications Port for remote HIM/communication options (Adapter 2) or Expansion Options (Adapters 2, 3, 4, 5) is located on the bottom of the enclosure (bottom of Main Control Board Mounting Plate for frames F-G).

Figure 2.9
Remote Device Distances



Human Interface Module

Chapter 3 describes the various controls and indicators found on the optional Human Interface Module (HIM). The material presented in this chapter must be understood to perform the start-up procedure in Chapter 4.

HIM Description

When the drive mounted HIM is supplied, it will be connected as Adapter 1 (see *Adapter Definitions* in Chapter 2) and visible from the front of the drive. The HIM can be divided into two sections; Display Panel and Control Panel. The Display Panel provides a means of programming the drive and viewing the various operating parameters. The Control Panel allows different drive functions to be controlled. Refer to Figure 3.1 and the sections that follow for a description of the panels.



ATTENTION: When a drive mounted HIM is not supplied on enclosed NEMA Type 1 (IP 20) drives, the blank cover plate (option HAB) must be installed to close the opening in the front cover of the enclosure. Failure to install the blank cover plate allows access to electrically live parts which may result in personal injury and/or equipment damage.

When a drive mounted HIM is supplied with enclosed NEMA Type 1 (IP 20) drives, but has been removed from its mounting cradle for remote operation, the blank cover plate must be installed in place of the HIM.

Important: The operation of some HIM functions will depend upon drive parameter settings. The default parameter values allow full HIM functionality.

Figure 3.1
Human Interface Module

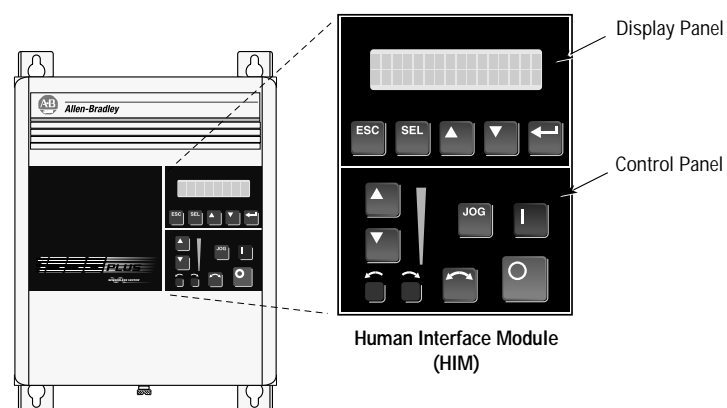
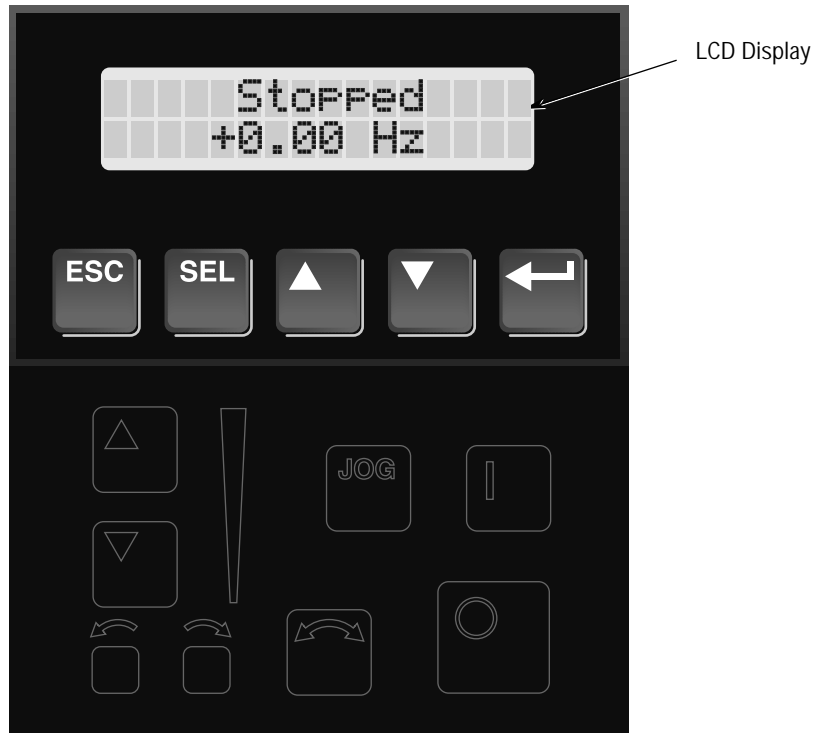


Figure 3.2
HIM Display Panel



Display Panel Key Descriptions



Escape

When pressed, the ESCape key will cause the programming system to go back one level in the menu tree.



Select

Pressing the SElect key alternately causes the top or bottom line of the display to become active. The flashing first character indicates which line is active.



Increment/Decrement

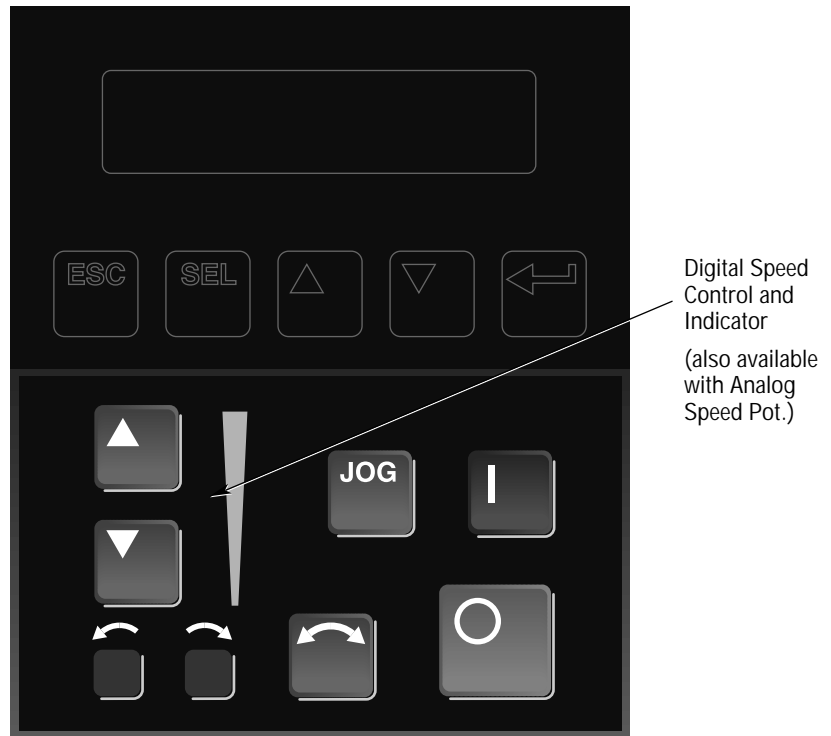
These keys are used to increment and decrement a value or scroll through different groups or parameters. Pressing both keys simultaneously while the Process or Password Display is shown, will save that display as the startup display.



Enter

When pressed, a group or parameter will be selected or a parameter value will be entered into memory. After a parameter has been entered into memory, the top line of the display will automatically become active, allowing another parameter (or group) to be chosen.

Figure 3.3
HIM Control Panel



Control Panel Key Descriptions



Start

The Start key will initiate drive operation if no other control devices are sending a Stop command. This key can be disabled by the [Logic Mask] or [Start Mask].



Stop

If the drive is running, pressing the Stop key will cause the drive to stop, using the selected stop mode. Refer to the [Stop Select 1] and [Stop Select 2] parameters in Chapter 5.

If the drive has stopped due to a fault, pressing this key will clear the fault and reset the drive. Refer to the [Flt Clear Mode], [Logic Mask] and [Fault Mask] parameters.



Jog

When pressed, jog will be initiated at the frequency set by the [Jog Frequency] parameter, if no other control devices are sending a Stop command. Releasing the key will cause the drive to stop, using the selected stop mode. Refer to [Stop Select 1], [Stop Select 2], [Logic Mask] and [Jog Mask].

Control Panel Key Descriptions *(Continued)*



Change Direction

Pressing this key will cause the drive to ramp down to zero Hertz and then ramp up to set speed in the opposite direction. The appropriate Direction Indicator will illuminate to indicate the direction of motor rotation. Refer to [Logic Mask] and [Direction Mask].



Direction LEDs (Indicators)

The appropriate LED will illuminate continuously to indicate the commanded direction of rotation. If the second LED is flashing, the drive has been commanded to change direction, but is still decelerating.



Up/Down Arrows *(only available with digital speed control)*

Pressing these keys will increase or decrease the HIM frequency command. An indication of this command will be shown on the visual Speed Indicator. The drive will run at this command if the HIM is the selected frequency reference. See [Freq Select 1] and [Freq Select 2].



Pressing both keys simultaneously stores the current HIM frequency command in HIM memory. Cycling power or removing the HIM from the drive will set the frequency command to the value stored in HIM memory.

If the Analog Speed Potentiometer option has been ordered, the Up/Down keys and Speed Indicator will be replaced by the pot.



Speed Indicator *(only available with digital speed control)*

Illuminates in steps to give an approximate visual indication of the commanded speed.

If the Analog Speed Potentiometer option has been ordered, the Up/Down keys and Speed Indicator will be replaced by the pot.

HIM Operation

When power is first applied to the drive, the HIM will cycle through a series of displays. These displays will show drive name, HIM ID number and communication status. Upon completion, the Status Display (see Figure 3.4) will be shown. This display shows the current status of the drive (i.e. “Stopped,” “Running,” etc.) or any faults that may be present (refer to Chapter 6 for fault information). On a Series A (version 3.0) or Series B HIM (see back of HIM) the Status Display can be replaced by the Process Display or Password Login menu. See appropriate sections on the following pages for more information.

Figure 3.4
Status Display



From this display, pressing any one of the 5 Display Panel keys will cause “Choose Mode” to be displayed. Pressing the Increment or Decrement keys will allow different modes to be selected as described below and shown in Figure 3.5. Refer to the pages that follow for operation examples.

Display

When selected, the Display mode allows any of the parameters to be viewed. However, parameter modifications are not allowed.

Process

The Process mode displays two user-selected parameters with text and scaling programmed by the user. Refer to Chapter 5 for further information.

Program

Program mode provides access to the complete listing of parameters available for programming. Refer to Chapter 5 for further parameter programming information.

EEProm

This mode allows all parameters to be reset to the factory default settings. In addition, a Series B HIM will allow parameter upload/download between the HIM and drive.

Search (*Series A, version 3.0 or Series B HIM Only*)

This mode will search for parameters that are not at their default values.

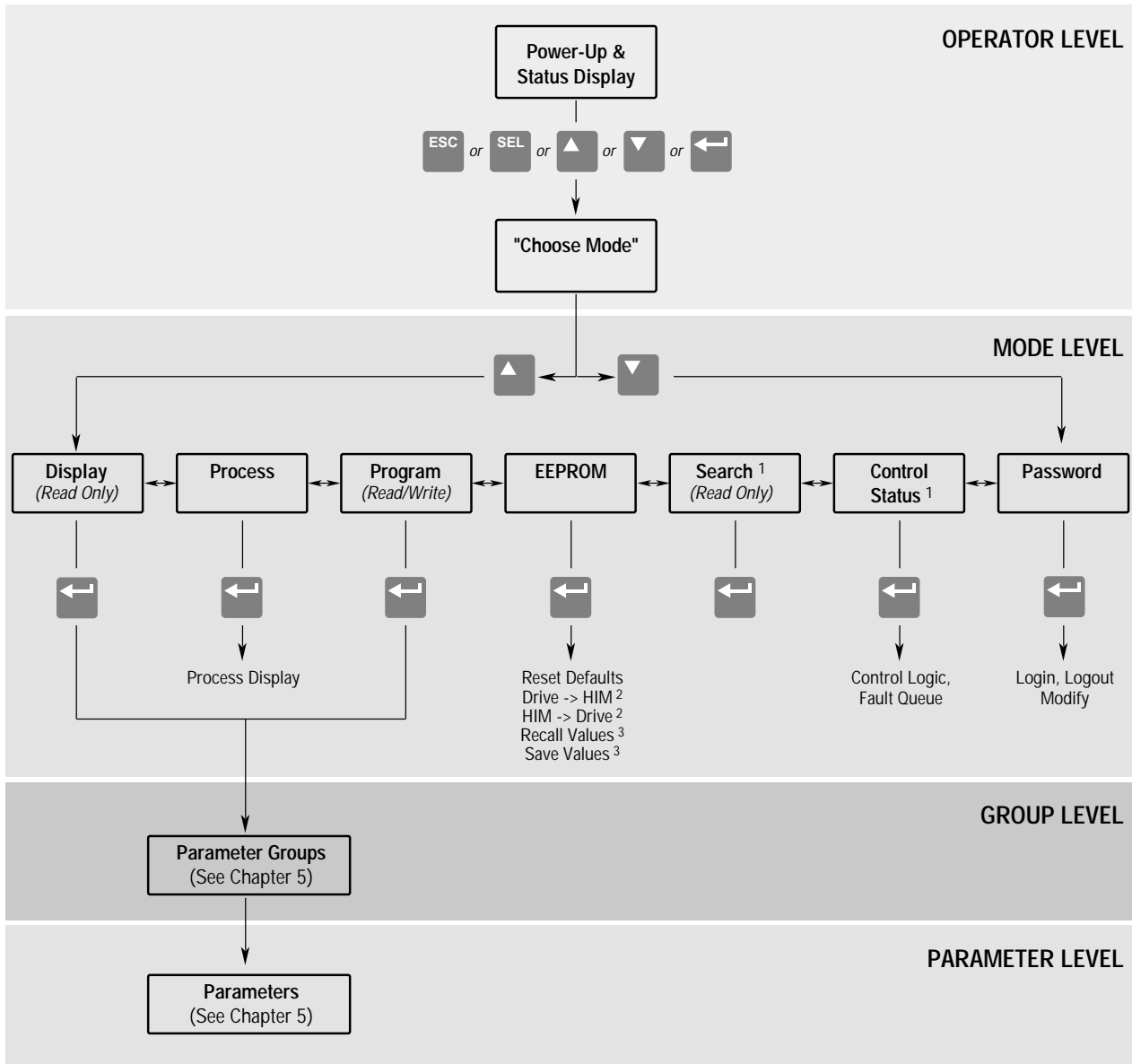
Control Status (*Series A, version 3.0 or Series B HIM Only*)

Permits the drive logic mask to be disabled/enabled allowing HIM removal while drive power is applied. Disabling the logic mask with a Series A HIM below version 3.0 can be accomplished with [Logic Mask] as explained on page 3-15. This menu also provides access to a fault queue which will list the last four faults that have occurred. “Trip” displayed with a fault indicates the actual fault that tripped the drive. A clear function clears the queue – it will not clear an active fault.

Password

The Password mode protects the drive parameters against programming changes by unauthorized personnel. When a password has been assigned, access to the Program/EEProm modes and the Control Logic/Clear Fault Queue menus can only be gained when the correct password has been entered. The password can be any five digit number between 00000 and 65535. Refer to the example on page 3-13.

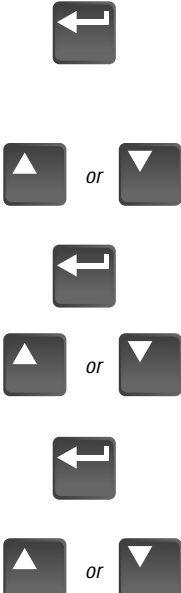



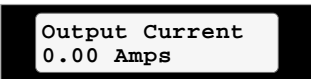
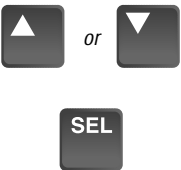

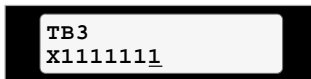
Figure 3.5
HIM Programming Steps























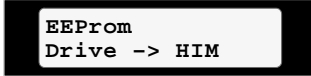
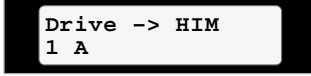
¹ Series A (Version 3.0) and Series B HIM Only.


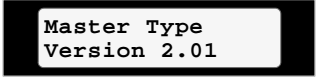

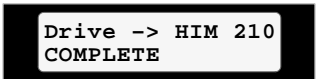


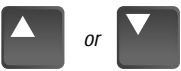




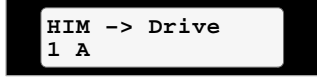
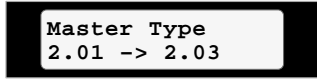


² Series B HIM Only.

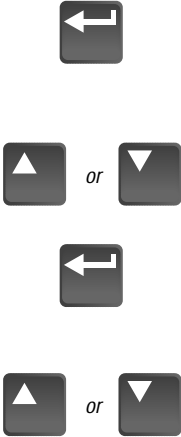


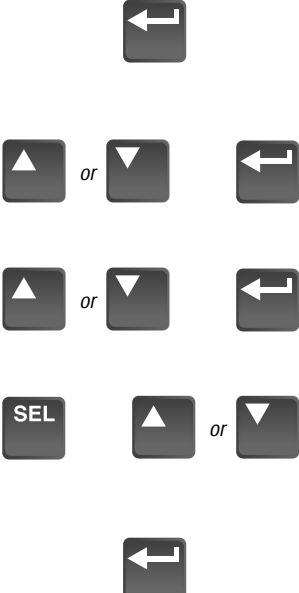


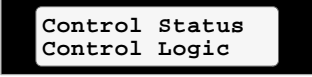
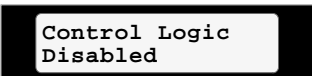
³ Reserved for Future Use.

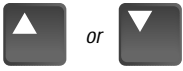
<p>Program and Display Modes</p> 	<p>1. The Display and Program modes allow access to the parameters for viewing or programming.</p> <p>A. From the Status Display, press Enter (or any key). “Choose Mode” will be shown.</p> <p>B. Press the Increment (or Decrement) key to show “Program” (or “Display”).</p> <p>C. Press Enter.</p> <p>D. Press the Increment (or Decrement) key until the desired group is displayed.</p> <p>E. Press Enter.</p> <p>F. Press the Increment (or Decrement) key to scroll to the desired parameter.</p>	   
<p>Bit ENUMs</p> 	<p>With drive software versions above 2.00 and a Series A (software version 3.0) or Series B HIM, bit ENUMs (16 character text strings) will be displayed to aid interpretation of bit parameters.</p> <p>G. Select a bit parameter with the Increment (or Decrement) keys.</p> <p>H. Press the SElect key to view the ENUM of the first bit. Pressing this key again will move the cursor to the left one bit.</p> <p>A blinking underline cursor will indicate that you are in the Display mode or that a Read Only parameter as been accessed. A flashing character will indicate that the value can be changed.</p> <p>Individual bits of a Read/Write parameter can be changed in the same manner. Pressing the SElect key will move the cursor (flashing character) one bit to the left. That bit can then be be changed by pressing the Increment/Decrement keys. When the cursor is in the far right position, pressing the Increment/Decrement keys will increment or decrement the entire value.</p>	 

<p style="text-align: center;">Process Mode</p> <div style="display: flex; justify-content: space-around; align-items: center;"> <div style="text-align: center;">▲</div> <div style="text-align: center;">or</div> <div style="text-align: center;">▼</div> <div style="text-align: center;">←</div> </div> <div style="display: flex; justify-content: space-around; align-items: center;"> <div style="text-align: center;">▲</div> <div style="text-align: center;">or</div> <div style="text-align: center;">▼</div> <div style="text-align: center;">←</div> </div> <div style="display: flex; justify-content: space-around; align-items: center;"> <div style="text-align: center;">▲</div> <div style="text-align: center;">or</div> <div style="text-align: center;">▼</div> <div style="text-align: center;">←</div> </div> <div style="display: flex; justify-content: space-around; align-items: center;"> <div style="text-align: center;">▲</div> <div style="text-align: center;">or</div> <div style="text-align: center;">▼</div> <div style="text-align: center;">←</div> </div> <div style="display: flex; justify-content: space-around; align-items: center;"> <div style="text-align: center;">ESC</div> <div style="text-align: center;">or</div> <div style="text-align: center;">▲</div> <div style="text-align: center;">or</div> <div style="text-align: center;">▼</div> </div> <div style="display: flex; justify-content: space-around; align-items: center;"> <div style="text-align: center;">←</div> <div style="text-align: center;">or</div> <div style="text-align: center;">▲</div> <div style="text-align: center;">or</div> <div style="text-align: center;">▼</div> </div> <div style="text-align: center; margin-bottom: 10px;">SEL</div> <div style="display: flex; justify-content: space-around; align-items: center;"> <div style="text-align: center;">▲</div> <div style="text-align: center;">and</div> <div style="text-align: center;">▼</div> </div>	<ol style="list-style-type: none"> 1. When selected, the Process mode will show a custom display consisting of information programmed with the Process Display group of parameters. <ol style="list-style-type: none"> A. Follow steps A-C on the preceding page to access the Program mode. B. Press the Increment/Decrement key until "Process Display" is shown. Press Enter. C. Using the Increment/Decrement keys, select [Process 1 Par] and enter the number of the parameter you wish to monitor. Press Enter. D. Select [Process 1 Scale] using the Increment/Decrement keys. Enter the desired scaling factor. Press Enter. E. Select [Process 1 Txt 1] using the Increment/Decrement keys. Enter the desired text character. Press Enter and repeat for the remaining characters. F. If desired, a second display line can also be programmed by repeating steps A-E for [Process 2 xxx] parameters. G. When process programming is complete, press ESCape until "Choose Mode" is displayed. Press Increment/Decrement until "Process" is displayed. H. Press Enter. This selects which custom display will be on line 1 and line 2. Use the Increment/Decrement keys to select process 1 or 2 parameters for line 1. I. Press SElect to move to line 2. Select the desired process parameters. With a Series A (version 3.0) or a Series B HIM, a zero can be entered to disable line 2. In addition, the Process Display can be set to appear when drive power is applied by simultaneously pressing the Increment and Decrement keys while the Process Display active. 	<div style="border: 1px solid black; padding: 5px; margin-bottom: 5px; background-color: #f0f0f0;">Choose Mode Program</div> <div style="border: 1px solid black; padding: 5px; margin-bottom: 5px; background-color: #f0f0f0;">Choose Group Process Display</div> <div style="border: 1px solid black; padding: 5px; margin-bottom: 5px; background-color: #f0f0f0;">Process 1 Par 1</div> <div style="border: 1px solid black; padding: 5px; margin-bottom: 5px; background-color: #f0f0f0;">Process 1 Scale 1.00</div> <div style="border: 1px solid black; padding: 5px; margin-bottom: 5px; background-color: #f0f0f0;">Process 1 Txt 1 v</div> <div style="border: 1px solid black; padding: 5px; margin-bottom: 5px; background-color: #f0f0f0;">Choose Mode Process</div> <div style="border: 1px solid black; padding: 5px; margin-bottom: 5px; background-color: #f0f0f0;">Process Var 1=1 Process Var 2=2</div> <p style="text-align: center;">Sets Process Display as Power-Up Display</p>
---	---	--

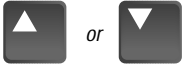
<p>EEProm Mode</p> <p>Reset Defaults</p>   or    or    	<p>The EEPROM mode is used to restore all settings to factory default values or upload/download parameters between the HIM and drive (Series B HIM, Only).</p> <p>1. To restore factory defaults:</p> <p>A. From the Status Display, press Enter (or any key). “Choose Mode” will be displayed.</p> <p>B. Press the Increment (or Decrement) key until “EEProm” is displayed. If EEPROM is not in the menu, programming is password protected. Refer to <i>Password Mode</i> later in this section.</p> <p>C. Press Enter.</p> <p>D. Press the Increment (or Decrement) key until “Reset Defaults” is displayed.</p> <p>E. Press Enter to restore all parameters to their original factory settings.</p> <p>F. Press ESC. “Reprogram Fault” will display.</p> <p>G. Press the Stop key to reset the fault.</p> <p>Important: If [Input Mode] was previously set to a value other than “1,” cycle drive power to reset.</p>	    
<p>Drive -> HIM</p>  or     or 	<p>2. To upload a parameter profile from the drive to the HIM, you must have a Series B HIM.</p> <p>A. From the EEPROM menu (see steps A-C above), press the Increment/Decrement keys until “Drive -> HIM” is displayed.</p> <p>B. Press Enter. A profile name (up to 14 characters) will be displayed on line 2 of the HIM. This name can be changed or a new name entered. Use the SEL key to move the cursor left. The Increment/Decrement keys will change the character.</p>	 

<p>Drive -> HIM (continued)</p> 	<p>C. Press Enter. An informational display will be shown, indicating the drive type and firmware version.</p> <p>D. Press Enter to start the upload. The parameter number currently being uploaded will be displayed on line 1 of the HIM. Line 2 will indicate total progress. Press ESC to stop the upload.</p> <p>E. "COMPLETE" displayed on line 2 will indicate a successful upload. Press Enter. If "ERROR" is displayed, see Chapter 6.</p>	  
<p>HIM -> Drive</p>      	<p>3. To download a parameter profile from the HIM to a drive, you must have a Series B HIM.</p> <p>Important: The download function will only be available when there is a valid profile stored in the HIM.</p> <p>A. From the EEPROM menu (see steps 1A-1C), press the Increment/Decrement keys until "HIM -> Drive" is displayed.</p> <p>B. Press the Enter key. A profile name will be displayed on line 2 of the HIM. Pressing the Increment/Decrement keys will scroll the display to a second profile (if available).</p> <p>C. Once the desired profile name is displayed, press the Enter key. An informational display will be shown, indicating the version numbers of the profile and drive.</p> <p>D. Press Enter to start the download. The parameter number currently being downloaded will be displayed on line 1 of the HIM. Line 2 will indicate total progress. Press ESC to stop the download.</p> <p>E. A successful download will be indicated by "COMPLETE" displayed on line 2 of the HIM. Press Enter. If "ERROR" is displayed, see Chapter 6.</p>	    

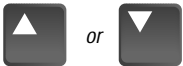
<p>Search Mode</p> 	<p>1. The Search Mode is only available with a Series A (version 3.0) or Series B HIM.</p> <p>This mode allows you to search through the parameter list and display all parameters that are not at the factory default values.</p> <p>A. From the Status Display, press Enter (or any key). “Choose Mode” will be shown.</p> <p>B. Press the Increment (or Decrement) key until “Search” is displayed.</p> <p>C. Press Enter. The HIM will search through all parameters and display any parameters that are not at their factory default values.</p> <p>D. Press the Increment (or Decrement) key to scroll through the list.</p>	 
<p>Control Status Mode</p> 	<p>1. The Control Status mode is only available with a Series A (version 3.0) or Series B HIM.</p> <p>This mode allows the drive logic mask to be disabled, thus preventing a Serial Fault when the HIM is removed with drive power applied. The logic mask can be disabled with Series A HIM versions below 3.0 by using [Logic Mask] as explained on page 3-15.</p> <p>A. From the Status Display, press Enter (or any key). “Choose Mode” will be shown.</p> <p>B. Press the Increment (or Decrement) key until “Control Status” is displayed. Press Enter.</p> <p>C. Select “Control Logic” using the Increment/Decrement keys. Press Enter.</p> <p>D. Press the SElect key, then use the Increment (or Decrement) key to select “Disabled” (or “Enable”).</p> <p>E. Press Enter. The logic mask is now disabled (or enabled).</p>	   

Control Status Mode *(continued)***Fault Queue/Clear Faults**

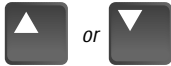
or



or



or



or



2. This menu provides a means to view the fault queue and clear it when desired.

- A. From the Control Status menu, press the Increment (or Decrement) key until “Fault Queue” is displayed.
- B. Press Enter.
- C. Press the Increment (or Decrement) key until “View Faults” is displayed.
- D. Press Enter. The fault queue will be displayed. “Trip” displayed with a fault will indicate the fault that tripped the drive.
- E. Use the Increment (or Decrement) key to scroll through the list.
- F. To clear the fault queue, press ESCape. Then use the Increment/Decrement keys to select “Clear Queue.” Press Enter. Please note that “Clear Queue” will not clear active faults.

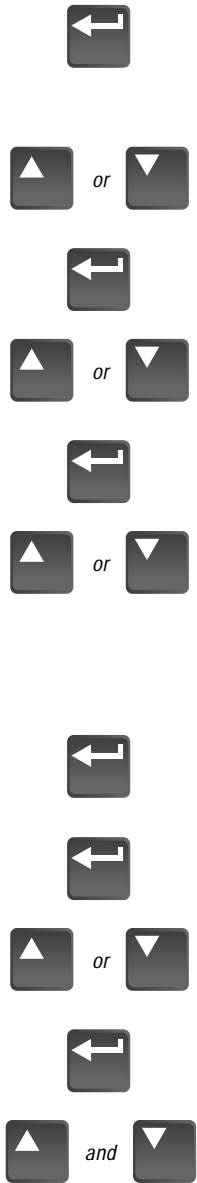

```
Control Status
Fault Queue
```

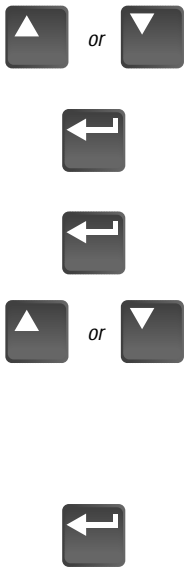
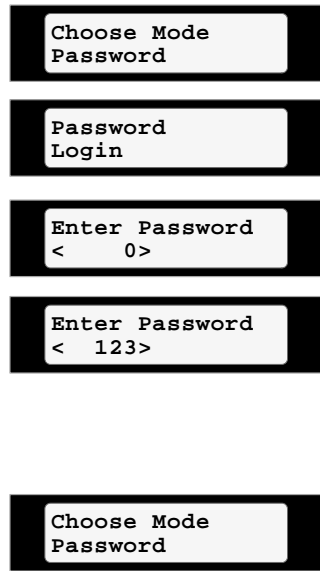
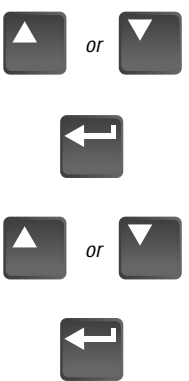
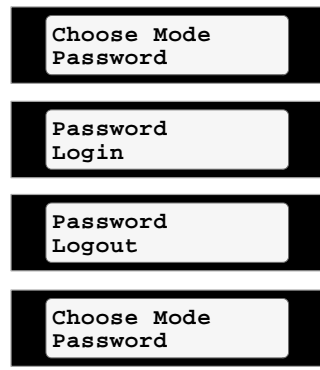
```
Fault Queue
View Faults
```

```
Serial Fault
F    10    Trip 1
```

```
Reprogram Fault
F    48    2
```

```
Fault Queue
Clear Queue
```

<p>Password Mode</p> 	<ol style="list-style-type: none"> 1. The factory default password is 0 (which disables password protection). To change the password and enable password protection, perform the following steps. <ol style="list-style-type: none"> A. From the Status Display, press Enter (or any key). “Choose Mode” will be shown. B. Press the Increment (or Decrement) key until “Password” is displayed. C. Press Enter. D. Press the Increment (or Decrement) key until “Modify” is displayed. E. Press Enter. “Enter Password” will be displayed. F. Press the Increment (or Decrement) key to scroll to your desired new password. With a Series A (version 3.0) or Series B HIM, the SElect key will move the cursor. G. Press Enter to save your new password. H. Press Enter again to return to the Password Mode. I. Press the Increment (or Decrement) key until “Logout” is displayed. J. Press Enter to log out of the Password mode. K. With a Series A (version 3.0) or Series B HIM, the Password mode can be programmed to appear when drive power is applied. Simultaneously press the Increment and Decrement keys while the Password display is shown. 	
--	--	--

<p>Password Mode <i>(continued)</i> Login to the Drive</p> 	<p>2. The Program/EEProm modes and the Control Logic/Clear Queue menus are now password protected and will not appear in the menu. To access these modes, perform the following steps.</p> <p>A. Press the Increment (or Decrement) key until “Password” is displayed.</p> <p>B. Press Enter. “Login” will be displayed.</p> <p>C. Press Enter, “Enter Password” will be displayed.</p> <p>D. Press the Increment (or Decrement) key until your correct password is displayed. With a Series A (version 3.0) or Series B HIM, the SElect key will move the cursor.</p> <p>E. Press Enter.</p> <p>F. The Program and EEPROM modes will now be accessible. To prevent future access to program changes, logout as described in step 1.</p>	
<p>Logout from the Drive</p> 	<p>3. To prevent unauthorized changes to parameters, Logout must be performed as described below.</p> <p>A. Press the Increment (or Decrement) key until “Password” is displayed.</p> <p>B. Press Enter.</p> <p>C. Press the Increment (or Decrement) key until “Logout” is displayed.</p> <p>D. Press Enter to log out of the Password mode.</p>	

Module Removal

For handheld operation, the module can be removed and located up to 10 meters (33 feet) from the drive. Refer to *Adapter Definitions* in Chapter 2 for details.



ATTENTION: Some voltages present behind the drive front cover are at incoming line potential. To avoid an electric shock hazard, use extreme caution when removing/replacing the HIM.

Important: Removing a HIM (or other SCANport device) from a drive while power is applied will cause a “Serial Fault,” unless the [Logic Mask] parameter has been set to disable this fault or Control Logic (Control Status menu) has been disabled (Series A, version 3.0 or Series B HIM). Setting Bit 1 of the [Logic Mask] parameter to “0” will disable “Serial Fault” from a HIM on port 1. Note that this also disables all HIM control functions except Stop.

To remove the module:

1. Assure that power has been removed, [Logic Mask] has been set or Control Logic has been disabled.
2. Take the drive front cover off and simply slide the module down and out of its cradle. Remove cable from module.
3. Connect the appropriate cable between the HIM and the Communications Port (Adapter 2, 3, 4 or 5).
4. Reverse the above steps to replace the module. Apply power, reset Bit 1 of the [Logic Mask] or enable Control Logic.

End of Chapter

Start-Up

This chapter describes how you start-up the 1336 PLUS Drive. Included are typical adjustments and checks to assure proper operation. The information contained in previous chapters of this manual must be read and understood before proceeding.

Important: The 1336 PLUS is designed so that start-up is simple and efficient. The programmable parameters are grouped logically so that most start-ups can be accomplished by adjusting parameters in only one group. Advanced features and adjustments are grouped separately. This eliminates having to constantly step through unneeded parameters on initial start-up.

This start-up procedure covers only the most commonly adjusted values.

Start-Up Procedure

The following start-up procedure is written for users who have a Human Interface Module (HIM) installed and who are not using a 2-wire drive control scheme. For users without a HIM, respective external commands and signals must be substituted to simulate their operation.



ATTENTION: Power must be applied to the drive to perform the following start-up procedure. Some of the voltages present are at incoming line potential. To avoid electric shock hazard or damage to equipment, only qualified service personnel should perform the following procedure. Thoroughly read and understand the procedure before beginning. If an event does not occur while performing this procedure, **Do Not Proceed. Remove Power** by opening the branch circuit disconnect device and correct the malfunction before continuing.

Important:

- Power must be applied to the drive when viewing or changing 1336 PLUS parameters. Previous programming may affect the drive status when power is applied.
- If the Control Interface option is installed, remote start circuits may be connected to TB3 on the interface board. Confirm that all circuits are in a de-energized state before applying power. User supplied voltages may exist at TB3 even when power is not applied to the drive.
- Refer to Chapter 6 for fault code information.


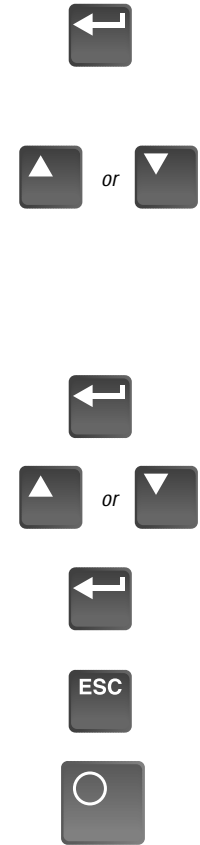






Initial Operation – Motor Disconnected

1. Verify that AC line power at the disconnect device is within the rated value of the drive. If a Control Interface option (L4, L5, L6, L4E, L5E, L6E) is installed, verify that the control power to this board matches the board rating.
2. Remove and lock-out all incoming power to the drive including incoming AC power to terminals R, S and T (L1, L2 and L3) plus any separate control power for remote interface devices. Remove the drive cover and disconnect the motor leads from TB1, terminals U, V, W (T1, T2 and T3).
3. If a Control Interface option is installed, verify that the Stop and Enable interlock inputs are present. If an [Input Mode] other than “1” is to be used, verify that the Auxiliary interlock input is present.

Important: The Stop and Enable inputs (and Auxiliary if required) must be present before the drive will start.

If this option is not installed, verify that two jumpers are installed at pins 3 & 4 and 17 & 18 of J4 on A Frame drives or J7 on B Frame and up drives. In addition, the [Input Mode] must be set to “1.”

4. Confirm that all other optional inputs are connected to the correct terminals and are secure.
5. The remainder of this procedure requires that a HIM be installed. If the HIM has a Control Panel, use the local controls to complete the start-up procedure. If a Control Panel is not present, remote devices must be used to operate the drive.
6. Replace the drive cover and tighten the thumbscrew(s).

<p>Apply Power</p>	<p>7. Apply AC power and control voltages to the drive. The LCD Display should light and display a drive status of “Stopped” and an output frequency of “+0.00 Hz.”</p> <p>If the drive detects a fault, a brief statement relating to the fault will be shown on the display. Record this information, remove all power and correct the fault source before proceeding. Refer to Chapter 6 for fault descriptions.</p>	
<p>Reset Factory Defaults</p> 	<p>8. Important: The remaining steps in this procedure are based on factory default parameter settings. If the drive has been previously operated, parameter settings may have been changed and may not be compatible with this start-up procedure or application. Drive status and fault conditions may be unpredictable when power is first applied.</p> <p>To obtain proper results, the parameters must be restored to factory default settings.</p> <p>A. From the Status Display, press Enter (or any key). “Choose Mode” will be displayed.</p> <p>B. Press the Increment (or Decrement) key until “EEPROM” is displayed. If EEPROM is not in the menu, programming is password protected. Refer to Chapter 3 for Password information.</p> <p>C. Press Enter.</p> <p>D. Press the Increment (or Decrement) key until “Reset Defaults” is displayed.</p> <p>E. Press Enter to restore all parameters to their original factory settings.</p> <p>F. Press ESC. “Reprogram Fault” will display.</p> <p>G. Press the Stop key to reset the fault.</p> <p>Important: If [Input Mode] was previously set to a value other than “1,” cycle drive power to reset.</p>	     

Program Input Mode



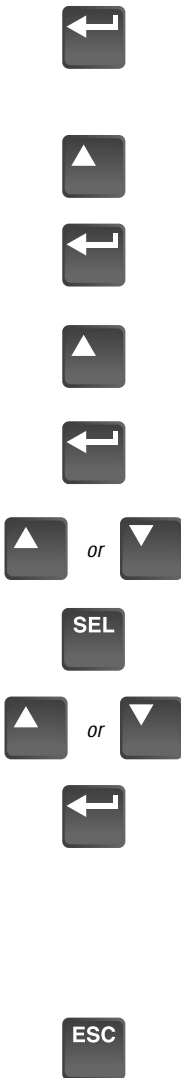
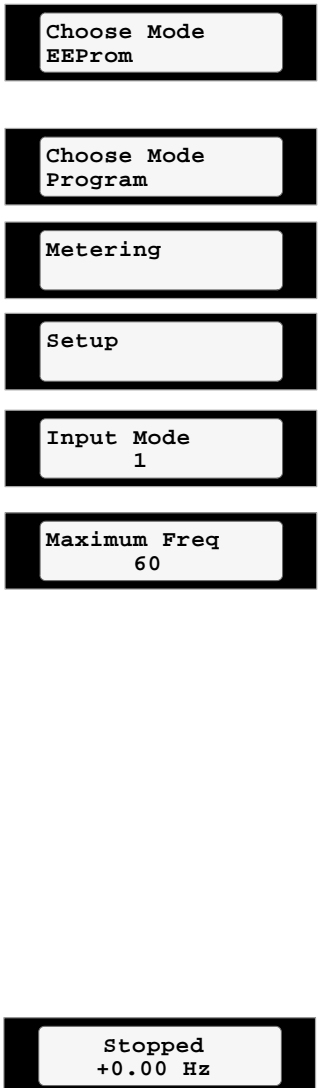
Cycle Input Power

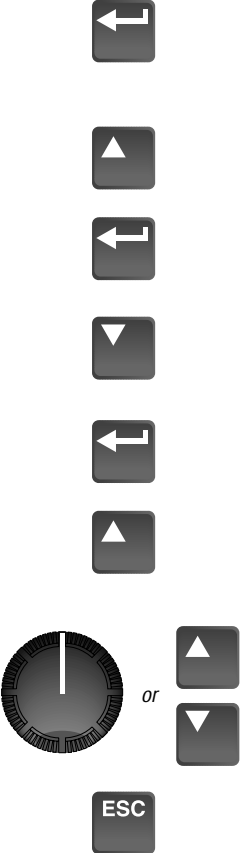
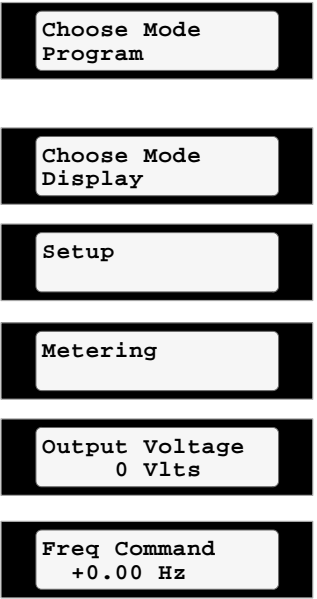

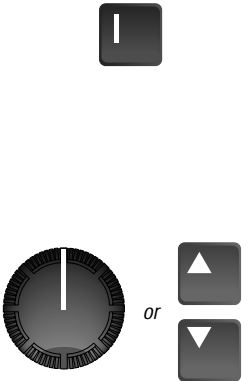
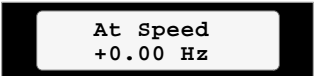
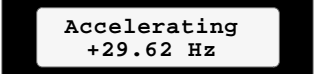

9. If a Control Interface option is installed, it is important that the Input Mode recorded in Chapter 2 be programmed into the drive. Since the control inputs to this option are programmable, incorrect operation can occur if an improper mode is selected. The factory default input mode disables all inputs except Stop and Enable. Verify your control scheme against the information provided in Chapter 2 and program the [Input Mode] parameter as follows:


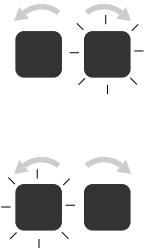
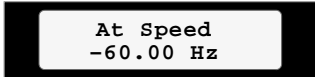


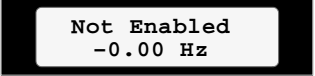
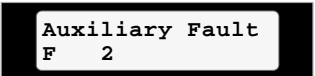

- A. From the Status Display, press the Enter key (or any key). “Choose Mode” will be displayed.
- B. Press the Increment (or Decrement) key until “Program” is displayed. If Program is not available, programming is password protected. Refer to Chapter 3 for Password mode information.
- C. Press Enter.
- D. Press the Increment key until “Setup” is displayed.
- E. Press Enter.
- F. Press SElect. The first character of line 2 will now flash.
- G. Press the Increment or Decrement keys until the correct mode is displayed, then press Enter. The first character of line 1 will now flash.
- H. Press the ESCape key (3 times) to return to the Status Display.
- I. Remove power to the drive. When the HIM Display is no longer illuminated, reapply power.









Important: Display must go blank for programming change to take affect.








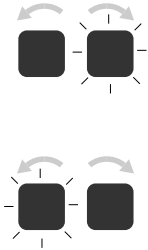
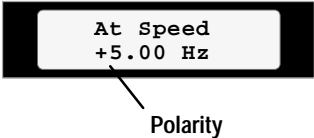


	<p>10. Set [Maximum Freq] and [Maximum Voltage] parameters to correct values (typically line voltage/frequency). Set [Base Voltage] and [Base Frequency] parameters to the motor nameplate values.</p> <p>A. From the Status Display, press the Enter key (or any key). “Choose Mode” will be displayed.</p> <p>B. Press the Increment (or Decrement) key until “Program” is displayed.</p> <p>C. Press Enter.</p> <p>D. Press the Increment key until “Setup” is displayed.</p> <p>E. Press Enter.</p> <p>F. Press the Increment or Decrement keys until “Maximum Freq” is displayed. Press SElect. The first character of line 2 will now flash.</p> <p>G. Use the Increment/Decrement keys to display the first digit, then press Enter. Repeat for remaining digits.</p> <p>H. Repeat the above steps to program the remaining parameters. In firmware versions 4.01 & up, the remaining parameters are located in the Motor Control group.</p> <p>I. Press the ESCape key (3 times) to return to the Status Display.</p>	
<p>Choose Sensorless Vector or V/Hz</p>	<p>11. Sensorless Vector or V/Hz operation. <i>Firmware Version 4.01 & Up Only</i></p> <p>Sensorless Vector or Volts/Hertz operation is selectable via [Control Select]. Vector operation is the default. If V/Hz operation is desired, reprogram [Control Select] using the steps above as a programming guide. Refer to page 5-51.</p>	

	<p>12. Setting Frequency Command.</p> <p>A. From the Status Display, press the Enter key (or any key). “Choose Mode” will be displayed.</p> <p>B. Press the Increment key until “Display” is shown.</p> <p>C. Press Enter.</p> <p>D. Press the Decrement key until “Metering” is displayed.</p> <p>E. Press Enter.</p> <p>F. Press the Increment key until “Freq Command” is displayed.</p> <p>G. If the frequency command is a value other than zero, use the speed source (digital, analog pot, etc.) to set the command to zero.</p> <p>H. After the command has been set to zero, press the ESCape key until the Status Display is shown.</p>	 
	<p>13. Verifying Minimum and Maximum Frequency Settings.</p> <p>A. Press the Start key. The drive should output zero Hz, which is the factory default value for the [Minimum Freq] parameter. The Status Display should indicate “At Speed” and the actual frequency (+0.00 Hz.).</p> <p>If the drive does not start, check bit 12 (Voltage Check) of the [Drive Alarm] parameter. If the bit is “1,” the drive terminal voltage is preventing the drive from starting. Normally this is caused by IGBT leakage current. To bypass this alarm, program [Flying Start En] to “Track Volts,” then start the drive.</p> <p>B. With the drive still running, use the speed source to command maximum speed. The drive should ramp to [Maximum Freq].</p>	  

	<p>14. Checking Direction.</p> <p>A. Initiate a Reverse command.</p> <p>Important: With [Direction Mask] set to the default value, the reverse command must be issued from the HIM or other adapter. If the reverse command is to be issued from TB3, [Direction Mask] must first be programmed to allow direction control from TB3.</p> <p>The drive will ramp to zero speed, then ramp to [Maximum Freq] in the opposite direction. The output frequency shown on the Display Panel will indicate speed with a “+” for forward or a “-” for reverse. As the drive decelerates, the Forward Direction LED will flash, indicating actual direction. During this time the Reverse Direction LED will illuminate continuously, indicating the commanded direction. Once zero Hertz is reached and the drive begins to accelerate in the reverse direction, the Forward LED will extinguish and the Reverse LED will illuminate continuously.</p>	 
<p>Open Enable Signal Restore Enable Signal</p>  <p>Open Auxiliary Signal Restore Auxiliary Signal</p> 	<p>15. If the Control Interface option is not installed, stop the drive and go to step 16.</p> <p>The following steps will check for correct drive operation when the Enable and Auxiliary inputs are removed.</p> <p>A. With the drive still running, open the Enable signal. The drive should stop and indicate “Not Enabled” on the display. Restore the Enable signal.</p> <p>B. If [Input Mode] is set to “1,” go to step 16.</p> <p>C. With the drive running, open the Auxiliary signal. The drive should stop and the display will indicate “Auxiliary Fault.” Restore the Auxiliary signal and reset the drive by pressing the Stop key.</p>	  

<p>Press & Hold Jog Key</p>  <p>Release Jog Key</p>	<p>16. Jog Control & Stop Mode Check.</p> <p>A. With the drive reset, but not running, press and hold the Jog key on the Control Panel. The motor should accelerate to the frequency programmed by the [Jog Frequency] parameter and remain there until the Jog key is released. When released, the drive should execute a stop function using the programmed stop mode. Verify that the correct stop mode was initiated.</p>	 
<p>Set to Maximum Frequency</p>   	<p>17. Checking Accel and Decel Times.</p> <p>A. Verify that the frequency command is at maximum frequency.</p> <p>B. Start the drive and observe the amount of time the drive takes to accelerate to maximum frequency. This should equal 10 seconds, which is the factory default value for the [Accel Time 1] parameter.</p> <p>C. Press the Reverse key and observe the amount of time the drive takes to decelerate from maximum frequency to zero. This time should equal the time set in the [Decel Time 1] parameter (default is 10 seconds). If these times are not correct for your application, refer to Chapter 5 for instructions on programming changes.</p> <p>Important: With [Direction Mask] set to the default value, the reverse command must be issued from the HIM or other adapter. If the reverse command is to be issued from TB3, [Direction Mask] must first be programmed to allow direction control from TB3.</p> <p>D. Stop the drive.</p>	
<p>Remove ALL Power</p>	<p>18. Reconnect the Motor.</p> <p>A. Remove and lock-out the input and control power to the drive. When the HIM Display is no longer illuminated, remove the drive cover.</p>	

<p>Reconnect Motor</p>	<p> ATTENTION: To avoid a hazard of electric shock, verify that the voltage on the bus capacitors has discharged. Measure the DC bus voltage at the + & – terminals of TB1. The voltage must be zero.</p> <p>B. Reconnect motor leads & replace cover.</p>	
<p>Apply Power to Drive</p> <p>Verify Frequency Command = 0</p> <p>Verify Forward Rotation</p> <p></p> <p>Slowly Increase Speed</p> <p> or  </p> <p>Verify Direction of Rotation</p> <p></p>	<p>19. Check for Correct Motor Rotation.</p> <p> ATTENTION: In the following steps, rotation of the motor in an undesired direction can occur. To guard against possible equipment damage, it is recommended that the motor be disconnected from the load before proceeding.</p> <p>A. Reapply power to the drive.</p> <p>B. Verify that the frequency command is at zero Hz. For further information, refer to step 12.</p> <p>C. Using the Direction LEDs, verify that forward direction is selected.</p> <p>D. Start the drive and slowly increase the speed until the motor begins to turn. Note the direction of motor rotation. If the direction of rotation is as desired, proceed to Step E.</p> <p>If the direction of motor rotation is incorrect, stop the drive and remove all power. When the HIM Display is no longer illuminated, remove the drive cover. Verify that the bus voltage measured at “DC +” & “DC –” of TB1 is zero (see Attention above). Interchange any two of the three motor leads at TB1 – U, V or W. Repeat Steps A through D.</p> <p>E. If encoder feedback is being used, verify that the polarity (“+” or “–”) of [Pulse/Enc Hertz] equals the polarity of the actual drive output as shown on the Status Display. If the polarities are the same, go to step F.</p> <p>If polarities are different, stop the drive, remove all power. Reverse the “A” & “A NOT” <u>OR</u> “B” & “B NOT” wiring. Repeat Steps A through D.</p> <p>F. Stop the drive and replace drive cover.</p>	<p></p> <p></p>

20. Low Speed Operation.

(Speed range greater than 20:1)

If **Volts/Hertz** operation was selected in step **11**, proceed to step **25**.

Slip @ F.L.A. Adjustment.

To increase the steady state torque performance of the motor at low speeds, the default Speed Control method is Slip Compensation. The factory default value for [Slip @ F.L.A.] is “1.0 Hz.” Optimum motor performance depends on accurate setting of [Slip @ F.L.A.].

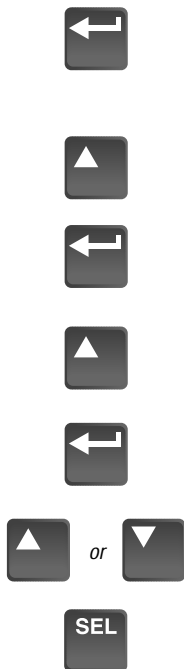
Estimate your motor slip value using the following:

$$\frac{\text{Motor Sync. RPM} - \text{Motor Rated RPM}}{\text{Motor Sync. RPM}} \times \text{Motor Rated Freq. (Hz)}$$

Example: $\frac{1800 - 1778}{1800} \times 60 = 0.7 \text{ Hz Slip @ F.L.A.}$

This will provide a starting point for slip compensation adjustment. If necessary, further adjustment can be made while the motor is under load.

Set Slip @ F.L.A. Value



A. From the Status Display, press the Enter key (or any key). “Choose Mode” will be displayed.

B. Press the Increment (or Decrement) key until “Program” is displayed.

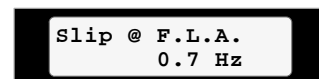
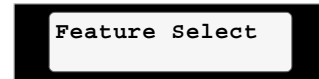
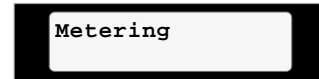
C. Press Enter.

D. Press the Increment key until “Feature Select” is displayed.

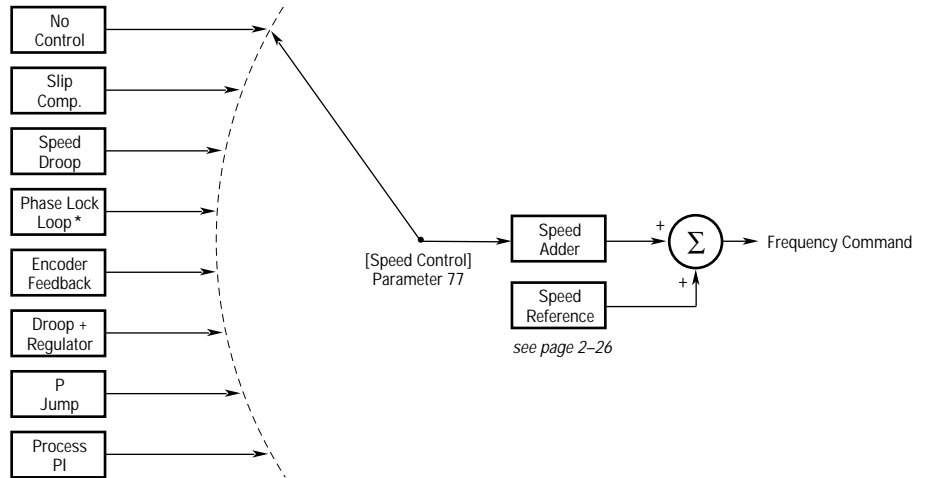
E. Press Enter.

F. Press the Increment or Decrement keys until “Slip @ F.L.A.” is displayed. Press SElect. The first character of line 2 will now flash.

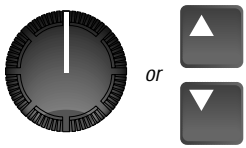

G. Use the Increment/Decrement keys to program the value calculated above, then press Enter.

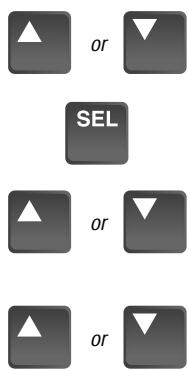


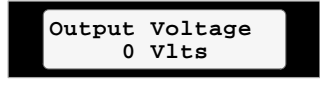




Speed Control Selection



* Firmware versions below 4.01 only.

<p>Program NP Data</p>	<p>21. Tuning Sensorless Vector operation. <i>Firmware Version 4.01 & Up Only</i></p> <p>To further improve drive performance in Sensorless Vector mode, the actual motor nameplate data can be entered directly.</p> <p>Refer to the motor nameplate and program the following Setup group parameters:</p> <p>[Motor NP Amps] [Motor NP Volts] [Motor NP Hertz] [Motor NP RPM].</p> <p>For the typical steps involved when programming, refer to step 20.</p>	
<p>Remove ALL Power to the Drive Disconnect Load Apply Power to Drive</p> 	<p>22. Optimum tuning requires motor rotation and can be achieved by running the drive/motor under a “no-load” condition.</p> <p>A. Remove all power to the drive. Disconnect the load from the system by decoupling the motor shaft. Reapply drive power.</p> <p>B. While monitoring [Freq Command] in the Metering group, adjust the speed source for the drive (digital, analog pot, etc.) to 45 Hz. <i>continued</i></p>	

	<p>C. Press the Increment/Decrement keys until “Flux Current” is displayed. Start the drive and record this value. Stop the drive.</p> <p>D. Press the Increment/Decrement keys to display “Freq Command.” Adjust the speed source for the drive to zero Hz.</p> <p>E. Press the Increment (or Decrement) key to display “Output Voltage.” Start the drive and record the value.</p> <p>F. Stop the drive.</p> <p>G. Program the values recorded above into the following parameters. [Flux Amps Ref] = [Flux Current] at 45 Hz. [IR Drop Volts] = [Output Voltage] at zero Hz.</p> <p>Important: Some motors (i.e. 6 pole, special, etc.) may be particularly sensitive to the adjustment of [IR Drop Volts]. If this tuning procedure does not give the desired performance, adjust [IR Drop Volts] up/down, 1 or 2 volts until desired response is achieved.</p>	 <p>Flux Current = _____ Amps</p>   <p>Output Voltage at 0 Hz = _____ volts</p>
<p>Adjusting Flux Up Time</p>	<p>23. On larger motors (37 kW/50 HP, typical) additional acceleration performance can be gained by adjusting [Flux Up Time]. This parameter determines the amount of time that the drive will inject current at [Current Limit] levels before acceleration begins. This <i>pre-acceleration</i> time builds flux in the motor to allow for optimum acceleration, and may result in shorter overall acceleration. If better performance is required, adjust [Flux Up Time]. Begin with 0.2 seconds (default is zero) and increase as necessary.</p> <p>For the typical steps involved when programming, refer to step 20.</p>	
<p>Tuning [Slip Comp Gain]</p>	<p>24. To adjust the recovery response to load changes [Slip Comp Gain] can be increased. However, increasing the gain value too high may cause system instability. The factory default value is set to minimum. Fine adjustment will require operation with a load.</p>	

<p>Set Power-Up Display</p> 	<p>25. With HIM software versions 2.02 & up, the power-up display (Status, Process or Password) can be programmed to appear when drive power is applied. Simply access the desired display and simultaneously press the Increment and Decrement keys.</p>	
<p>Set Electronic Overload</p>	<p>26. Electronic overload protection is factory set to drive maximum.</p> <p>A. To properly set the electronic overload protection, program [Overload Amps] (Setup group) to the actual nameplate F.L.A.</p> <p>B. If the motor speed range is greater than 2:1, program [Overload Mode] to the proper derate.</p> <p>For the typical steps involved when programming, refer to step 20.</p>	
	<p>27. This completes the basic start-up procedure. Depending on your application, further parameter programming may be required. Refer to Chapter 5 for information.</p>	
	<p>28. If password protection is enabled, log out as described in Chapter 3.</p>	

End of Chapter

Programming

Chapter 5 describes parameter information for the 1336 PLUS. Parameters are divided into 14 groups for ease of programming and operator access. Grouping replaces a sequentially numbered parameter list with functional parameter groups that increases operator efficiency and helps to reduce programming time. For most applications, this means simplicity at startup with minimum drive tuning.

Function Index

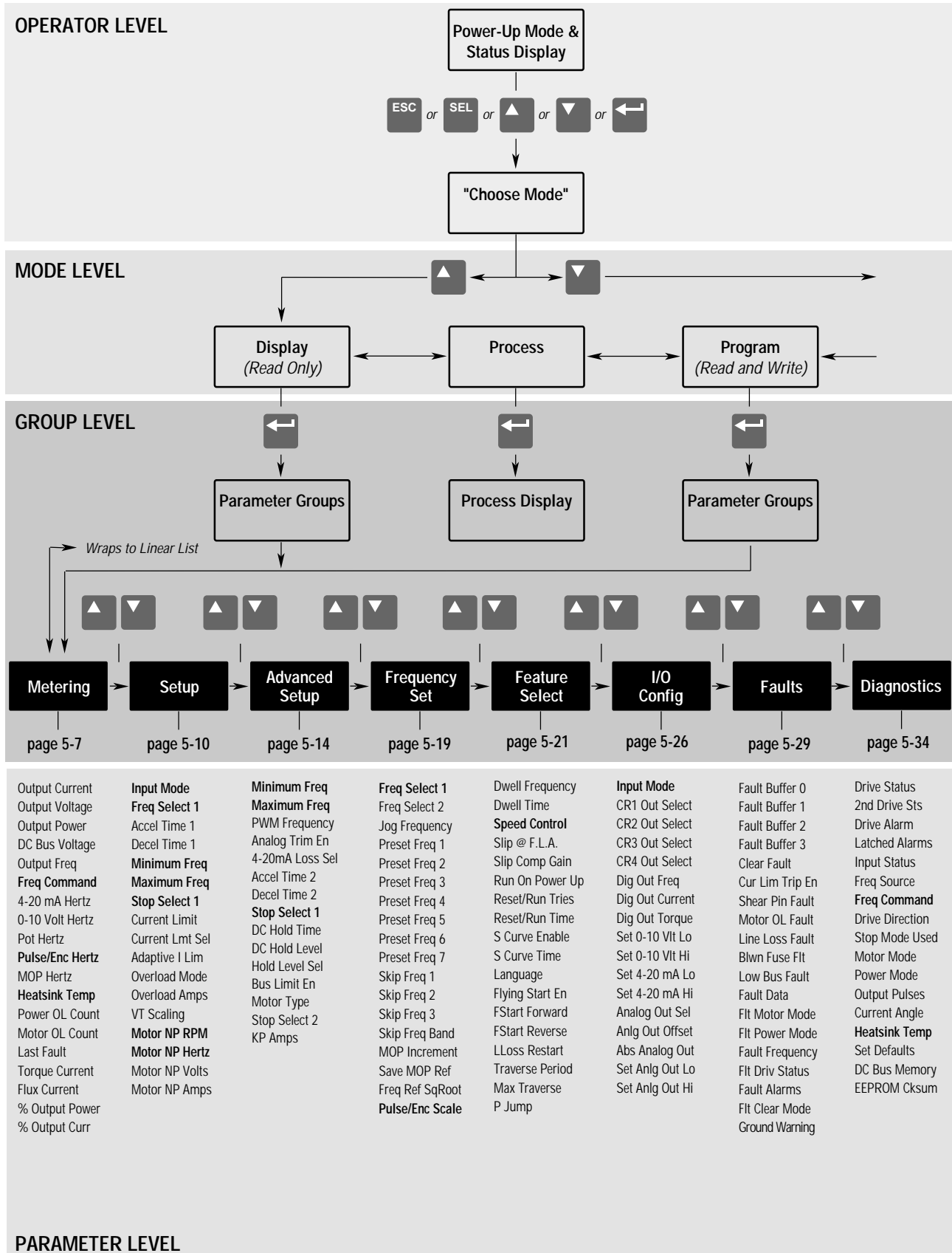
The Function Index shown below provides a directory of the parameters required for each drive function. The Page Number locates within a group all parameters associated with that specific function.

<u>Function</u>	<u>Page Number</u>
Analog Input Config	5-15
Auto Restart	5-22
Custom Volts-per-Hertz	5-51
DC Brake-to-Stop	5-17
DC Hold Brake	5-17
Dwell	5-21
Economize	5-51
Electronic Shear Pin	5-29
Encoder Feedback	5-45
Fault Buffer History	5-29
Frequency Select	5-19
I/O Configuration	5-26
Last Speed	5-19
Line Loss Recovery	5-24
Minimum/Maximum Frequency	5-11
Overload Protection	5-12
Preset Frequencies	5-19
Process Control	5-47
Process Display	5-44
Remote I/O	5-43
S-Curve Acceleration	5-23
Skip Frequencies	5-20
Slip Compensation	5-22
Stop Modes	5-16
Traverse Function	5-25

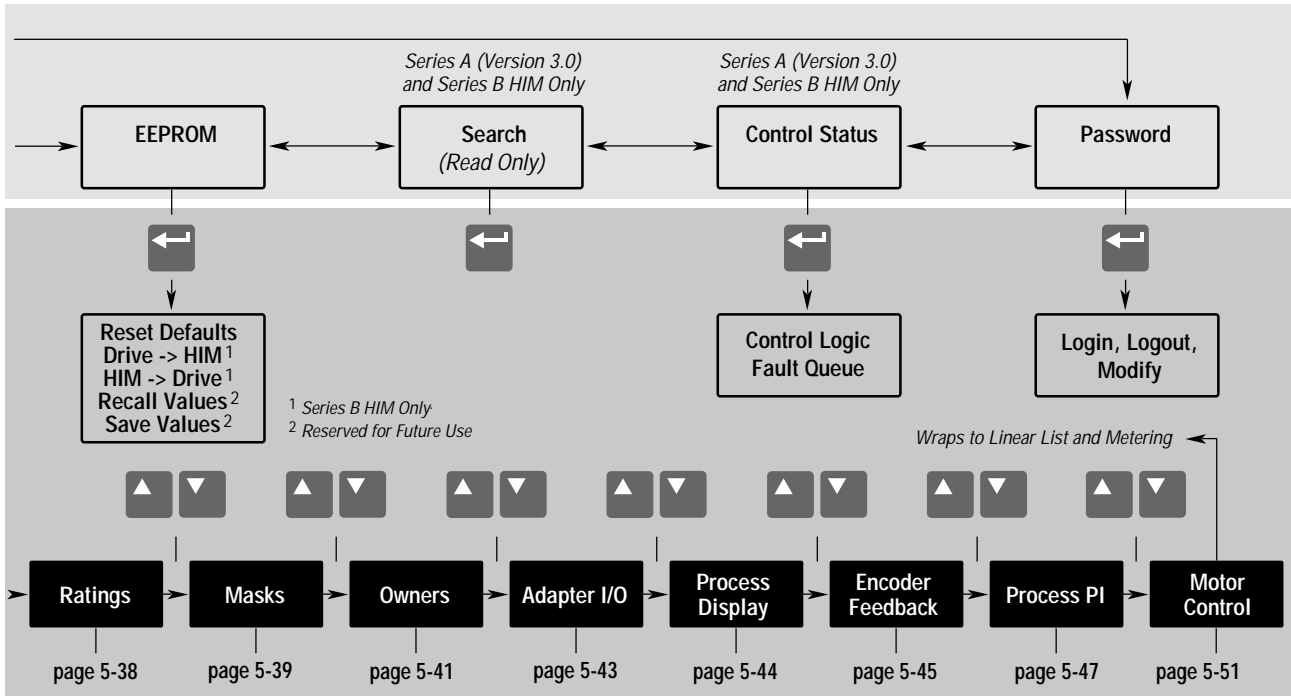
Programming Flow Chart

The flow charts provided on pages 5-2 through 5-5 highlight the steps required to access each group of parameters and lists all parameters for each group.

Important: Series A (Version 3.0) and Series B HIM software versions (see back of HIM) provide several new functions, including; Search, Control Status and Bit ENUMs. Refer to Chapter 3 for a description of these functions.

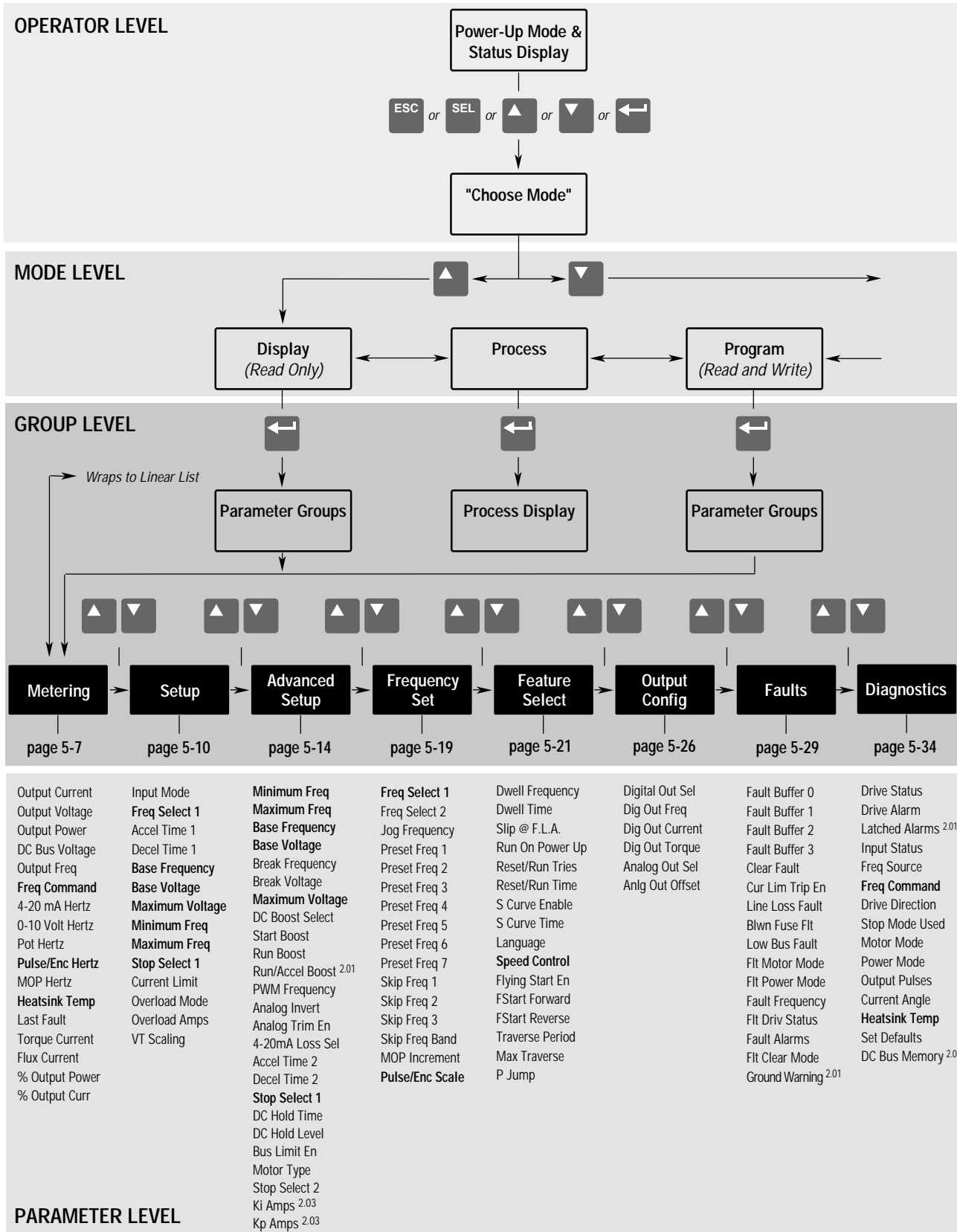


FIRMWARE VERSIONS 4.01 & UP

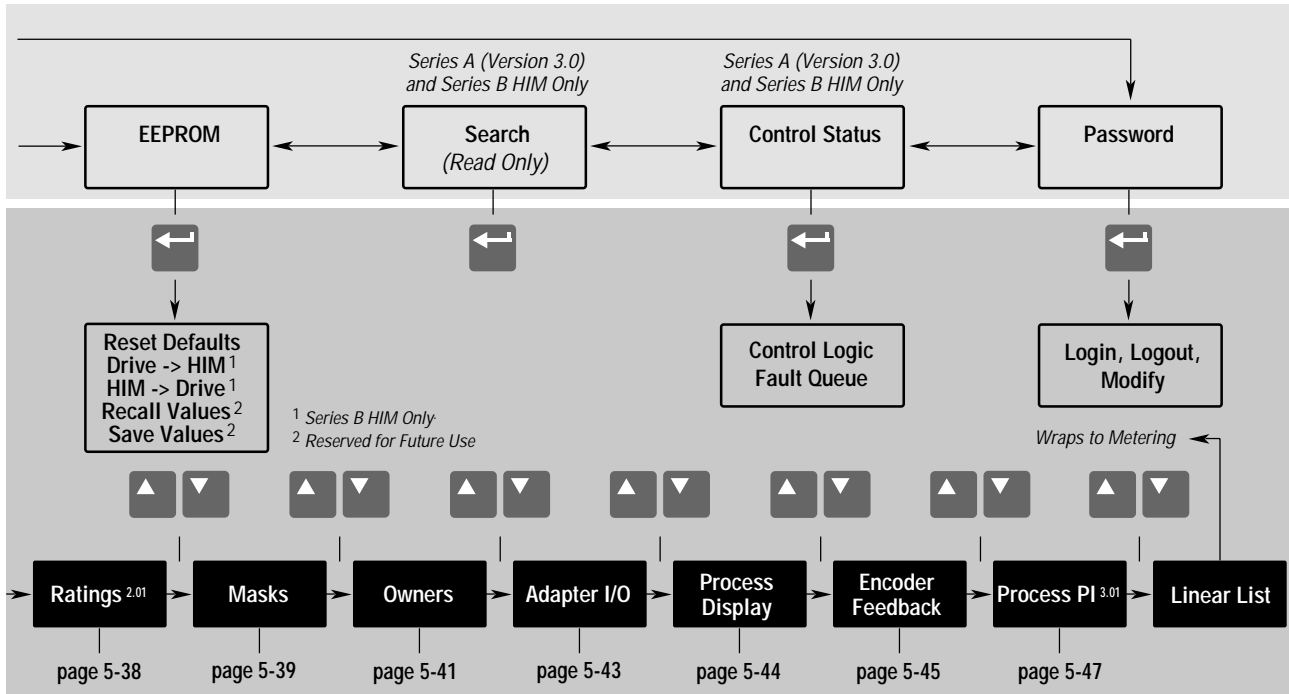


Drive Type	Direction Mask	Stop Owner	Data In A1	Process 1 Par	Speed Control	Speed Control	Control Select
Firmware Ver.	Start Mask	Direction Owner	Data In A2	Process 1 Scale	Encoder Type	PI Config	Flux Amps Ref
Drive Rtd Volts	Jog Mask	Start Owner	Data In B1	Process 1 Txt 1	Pulse/Enc Scale	PI Status	IR Drop Volts
Rated Amps	Reference Mask	Jog Owner	Data In B2	Process 1 Txt 2	Maximum Speed	PI Ref Select	Flux Up Time
Rated kW	Accel Mask	Reference Owner	Data In C1	Process 1 Txt 3	Motor Poles	PI Fdbk Select	Start Boost
Rated CT Amps	Decel Mask	Accel Owner	Data In C2	Process 1 Txt 4	Speed KI	PI Reference	Run Boost
Rated CT kW	Fault Mask	Decel Owner	Data In D1	Process 1 Txt 5	Speed Error	PI Feedback	Boost Slope
Rated VT Amps	MOP Mask	Fault Owner	Data In D2	Process 1 Txt 6	Speed Integral	PI Error	Break Voltage
Rated VT kW	Logic Mask	MOP Owner	Data Out A1	Process 1 Txt 7	Speed Adder	PI Output	Break Frequency
	Local Mask	Local Owner	Data Out A2	Process 1 Txt 8	Motor NP RPM	KI Process	Base Voltage
	Alarm Mask		Data Out B1	Process 2 Par	Motor NP Hertz	KP Process	Base Frequency
			Data Out B2	Process 2 Scale	Pulse/Enc Hertz	PI Neg Limit	Maximum Voltage
			Data Out C1	Process 2 Txt 1		PI Pos Limit	
			Data Out C2	Process 2 Txt 2		PI Preload	
			Data Out D1	Process 2 Txt 3			
			Data Out D2	Process 2 Txt 4			
				Process 2 Txt 5			
				Process 2 Txt 6			
				Process 2 Txt 7			
				Process 2 Txt 8			

Note: Parameters that appear in more than one group are shown in **Bold**



FIRMWARE VERSIONS 1.05 – 3.01



Drive Type ^①	Direction Mask	Stop Owner	Data In A1	Process 1 Par	Speed Control	PI Config
Firmware Ver. ^①	Start Mask	Direction Owner	Data In A2	Process 1 Scale	Encoder Type	PI Ref Select
Drive Rtd Volts ^①	Jog Mask	Start Owner	Data In B1	Process 1 Txt 1	Pulse/Enc Scale	PI Fdbk Select
Rated Amps ^①	Reference Mask	Jog Owner	Data In B2	Process 1 Txt 2	Maximum Speed	PI Reference
Rated kW ^①	Accel Mask	Reference Owner	Data In C1	Process 1 Txt 3	Motor Poles	PI Feedback
Rated CT Amps ^①	Decel Mask	Accel Owner	Data In C2	Process 1 Txt 4	Speed KI	PI Error
Rated CT kW ^①	Fault Mask	Decel Owner	Data In D1	Process 1 Txt 5	Speed Error	PI Output
Rated VT Amps ^①	MOP Mask	Fault Owner	Data In D2	Process 1 Txt 6	Speed Integral	Ki Process
Rated VT kW ^①	Logic Mask	MOP Owner	Data Out A1	Process 1 Txt 7	Speed Adder	Kp Process
	Local Mask	Local Owner	Data Out A2	Process 1 Txt 8	Motor NP RPM	PI Neg Limit
	Alarm Mask ^{2.01}		Data Out B1	Process 2 Par	Motor NP Hertz	PI Pos Limit
			Data Out B2	Process 2 Scale	Pulse/Enc Hertz ^{2.01}	
			Data Out C1	Process 2 Txt 1		
			Data Out C2	Process 2 Txt 2		
			Data Out D1	Process 2 Txt 3		
			Data Out D2	Process 2 Txt 4		
				Process 2 Txt 5		
				Process 2 Txt 6		
				Process 2 Txt 7		
				Process 2 Txt 8		

^{2.01} Firmware version 2.01 or later.

^{2.03} Firmware version 2.03 or later.

^{3.01} Firmware version 3.01 or later.

^① Located in the "Diagnostics" group for firmware versions before 2.01.

Note: Parameters that appear in more than one group are shown in **Bold**

Chapter Conventions

Parameter descriptions adhere to the following conventions.

1. All parameters required for any given drive function will be contained within a group, eliminating the need to change groups to complete a function.
2. All parameters are documented as either having ENUMS or Engineering Units.

ENUMS

[Parameter Name]	Parameter Number	①	#
	Parameter Type	②	Read Only or Read/Write
Parameter description.	Factory Default	③	Drive Factory Setting
	Units		Display / Drive ENUM Text / Internal Drive Units ④ / ⑤

Engineering Units

[Parameter Name]	Parameter Number	①	#
	Parameter Type	②	Read Only or Read/Write
Parameter description.	Display Units / Drive Units	④, ⑤	User Units / Internal Drive Units
	Factory Default	③	Drive Factory Setting
	Minimum Value	⑥	Min Value Acceptable
	Maximum Value	⑦	Max Value Acceptable

- ① **Parameter Number** Each parameter is assigned a number. The number can be used for process display setup, fault buffer interpretation or serial communication.
- ② **Parameter Type** 2 types of parameters are available:
Read Only The value is changed only by the drive and is used to monitor values.
Read/Write The value is changed through programming. This type can also be used to monitor a value.
- ③ **Factory Default** This is the value assigned to each parameter at the factory.
- ④ **Display Units** The units that appear on the HIM display. 2 types exist:
ENUMS A language statement pertaining to the selection made or language description of bit function.
Engineering Standard units such as; Hz, sec, volts, etc.
- ⑤ **Drive Units** These are internal units used to communicate through the serial port, and to scale values properly when reading or writing to the drive.
- ⑥ **Minimum Value** This is the lowest setting possible for parameters that do not use ENUMS.
- ⑦ **Maximum Value** This is the highest setting possible for parameters that do not use ENUMS.

3. To help differentiate parameter names and display text from other text in this manual, the following conventions will be used:
 - Parameter Names will appear in [brackets]
 - Display Text will appear in “quotes”.

Metering

This group of parameters consists of commonly viewed drive operating conditions such as motor speed, drive output voltage, current and command frequency. All parameters in this group are Read Only and can only be viewed.

[Output Current]

This parameter displays the output current present at TB1, terminals T1, T2 & T3 (U, V & W).

Parameter Number	54
Parameter Type	Read Only
Display Units / Drive Units	0.1 Amp / 4096 = Rated Amps
Factory Default	None
Minimum Value	0.0
Maximum Value	200% Rated Drive Output Current

[Output Voltage]

This parameter displays the output voltage present at TB1, terminals T1, T2 & T3 (U, V & W).

Parameter Number	1
Parameter Type	Read Only
Display Units / Drive Units	1 Volt / 4096 = Drive Rtd Volts
Factory Default	None
Minimum Value	0
Maximum Value	200% Rated Drive Output Voltage

[Output Power]

This parameter displays the output power present at TB1, terminals T1, T2 & T3 (U, V & W).

Parameter Number	23
Parameter Type	Read Only
Display Units / Drive Units	1 kilowatt / 4096 = Drive Rated kW
Factory Default	None
Minimum Value	-200% Rated Drive Output Power
Maximum Value	+200% Rated Drive Output Power

[DC Bus Voltage]

This parameter displays the DC bus voltage level.

Parameter Number	53
Parameter Type	Read Only
Display Units / Drive Units	1 Volt / 4096 = Drive Rtd Volts
Factory Default	None
Minimum Value	0
Maximum Value	200% DC Bus Voltage Max

[Output Freq]

This parameter displays the output frequency present at TB1, terminals T1, T2 & T3 (U, V & W).

Parameter Number	66
Parameter Type	Read Only
Display Units / Drive Units	0.01 Hertz / 32767 = Maximum Freq Forward
Factory Default	None
Minimum Value	-400.00 Hz
Maximum Value	+ 400.00 Hz

[Freq Command]

This parameter displays the frequency that the drive is commanded to output. This command may come from any one of the frequency sources selected by [Freq Select 1] or [Freq Select 2].

Parameter Number	65
Parameter Type	Read Only
Display Units / Drive Units	0.01 Hertz / 32767 = Maximum Freq Forward
Factory Default	None
Minimum Value	-400.00 Hz
Maximum Value	+ 400.00 Hz

Metering

[4-20 mA Hertz] This parameter displays the frequency command present at analog current input terminals 4 & 6 of TB2. This value is displayed whether or not this is the active frequency command.	Parameter Number	140
	Parameter Type	Read Only
	Display Units / Drive Units	0.01 Hertz / 32767 = Maximum Freq
	Factory Default	None
	Minimum Value	0.00 Hz
	Maximum Value	400.00 Hz

[0-10 Volt Hertz] This parameter displays the frequency command present at analog voltage input terminals 4 & 5 of TB2. This value is displayed whether or not this is the active frequency command.	Parameter Number	139
	Parameter Type	Read Only
	Display Units / Drive Units	0.01 Hertz / 32767 = Maximum Freq
	Factory Default	None
	Minimum Value	0.00 Hz
	Maximum Value	400.00 Hz

[Pot Hertz] This parameter displays the frequency command present at remote pot terminals 1, 2 & 3 of TB2. This value is displayed whether or not this is the active frequency command.	Parameter Number	138
	Parameter Type	Read Only
	Display Units / Drive Units	0.01 Hertz / 32767 = Maximum Freq
	Factory Default	None
	Minimum Value	0.00 Hz
	Maximum Value	400.00 Hz

[Pulse/Enc Hertz] This parameter displays the frequency command present at pulse input terminals 7 & 8 of TB2 or at the encoder input terminals on TB3 (if present). This value is displayed whether or not this is the active frequency command.	Parameter Number	63
	Parameter Type	Read Only
	Display Units / Drive Units	0.01 Hertz / 32767 = Maximum Freq
	Factory Default	None
	Minimum Value	0.00 Hz
	Maximum Value	400.00 Hz

[MOP Hertz] This parameter displays the frequency command from the MOP. The MOP frequency command can be adjusted by TB3 (if present) and an appropriate [Input Mode] is selected (see <i>Input Mode Selection</i> figure in Chapter 2). Some SCANport adapters, including the RIO Adapter, can also adjust the MOP frequency command. This value is displayed whether or not this is the active frequency command.	Parameter Number	137
	Parameter Type	Read Only
	Display Units / Drive Units	0.01 Hertz / 32767 = Maximum Freq
	Factory Default	None
	Minimum Value	0.00 Hz
	Maximum Value	400.00 Hz

[Heatsink Temp] This parameter displays the heatsink temperature.	Parameter Number	70
	Parameter Type	Read Only
	Display Units / Drive Units	1° C / Deg. C
	Factory Default	None
	Minimum Value	0
	Maximum Value	255° C

Metering

[Power OL Count]– Firmware 4.01 & later

Displays the percentage of accumulated I^2t for the drive thermal overload protection. Running continuously above 115% of drive rated amps will accumulate a value of 100% and generate an Overtemp Fault (F08).

Parameter Number	84
Parameter Type	Read Only
Display Units / Drive Units	1 % / 4096 = 100%
Factory Default	None
Minimum Value	0%
Maximum Value	200%

[Motor OL Count]– Firmware 4.01 & later

This parameter displays the percentage of accumulated I^2t for the motor overload protection. Running continuously at programmed [Overload Amps] will accumulate approximately 70%. Reduction of load will reduce the OL count. 100% value will generate an Overload Fault (F07).

Parameter Number	202
Parameter Type	Read Only
Display Units / Drive Units	1 % / 4096 = 100%
Factory Default	None
Minimum Value	0%
Maximum Value	200%

[Last Fault]

This parameter displays the last drive fault. It is updated whenever a new fault occurs.

Parameter Number	4
Parameter Type	Read Only
Display Units / Drive Units	Fault Number / Fault Number
Factory Default	None
Minimum Value	None
Maximum Value	None

[Torque Current]

This parameter displays the amount of current that is in phase with the fundamental voltage component. It is the current that is actually producing torque.

Parameter Number	162
Parameter Type	Read Only
Display Units / Drive Units	0.1 Amp / 4096 = Rated Amps (Motoring)
Factory Default	None
Minimum Value	-200% Drive Rating
Maximum Value	+200% Drive Rating

[Flux Current]

This parameter displays the amount of current that is out of phase with the fundamental voltage component. It is the current required to maintain motor flux.

Parameter Number	163
Parameter Type	Read Only
Display Units / Drive Units	0.1 Amp / 4096 = Rated Amps (Motoring)
Factory Default	None
Minimum Value	-200% Drive Rating
Maximum Value	+200% Drive Rating

[% Output Power]

This parameter displays the % output power of the drive.

Parameter Number	3
Parameter Type	Read Only
Display Units / Drive Units	1 % / $\pm 4096 = \pm 100\%$
Factory Default	None
Minimum Value	-200% Drive Rated Output Power
Maximum Value	+200% Drive Rated Output Power

[% Output Curr]

This parameter displays the % output current of the drive.

Parameter Number	2
Parameter Type	Read Only
Display Units / Drive Units	1 % / 4096 = 100%
Factory Default	None
Minimum Value	0%
Maximum Value	200% Rated Drive Output Current

Setup

This group of parameters defines basic operation and should be programmed before initial use of the drive. For advanced programming and information on specific parameters, refer to the flow chart on pages 5-2 & 5-3.

[Input Mode]

This parameter selects the functions of inputs 1-8 at TB3 when an optional interface card is installed. Refer to *Input Mode Selection* figure in Chapter 2. This parameter cannot be changed while the drive is running. Power to the drive must be cycled before any changes will affect drive operation.

Parameter Number	21
Parameter Type	Read and Write
Display Units / Drive Units	Mode Number / Selection
Factory Default	1
Minimum Value	1
Maximum Value	24

[Freq Select 1]

This parameter controls which of the frequency sources is currently supplying the [Freq Command] to the drive unless [Freq Select 2] or [Preset Freq 1-7] is selected.

Parameter Number	5
Parameter Type	Read and Write
Factory Default	"Adapter 1"
Units	Display Drive
	"Adapter 1" 6
	"Adapter 2" 7
	"Adapter 3" 8
	"Adapter 4" 9
	"Adapter 5" 10
	"Adapter 6" 11
	"Preset 1-7" 12-18
	"Use Last" 0
	"Remote Pot" 1
	"0-10 Volt" 2
	"4-20 mA" 3
	"Pulse Ref" 4 Refer to [Pulse/Enc Scale] Scale Value
	"MOP" 5

[Accel Time 1]

This value determines the time it will take the drive to ramp from 0 Hz to [Maximum Freq]. The rate determined by this value and [Maximum Freq] is linear unless [S Curve Enable] is "Enabled." It applies to any increase in command frequency unless [Accel Time 2] is selected.

Parameter Number	7
Parameter Type	Read and Write
Display Units / Drive Units	0.1 Second / Seconds x 10 (x 100 frn < 4.01)
Factory Default	10.0 Sec
Minimum Value	0.0 Sec
Maximum Value	3600.0 Sec (600.0 frn < 4.01)

Important: Please note the resolution and Maximum Value changes with Frn 4.01.

[Decel Time 1]

This value determines the time it will take the drive to ramp from [Maximum Freq] to 0 Hz. The rate determined by this value and [Maximum Freq] is linear unless [S Curve Enable] is "Enabled." It applies to any decrease in command frequency unless [Decel Time 2] is selected.

Parameter Number	8
Parameter Type	Read and Write
Display Units / Drive Units	0.1 Second / Seconds x 10 (x 100 frn < 4.01)
Factory Default	10.0 Sec
Minimum Value	0.0 Sec
Maximum Value	3600.0 Sec (600.0 frn < 4.01)

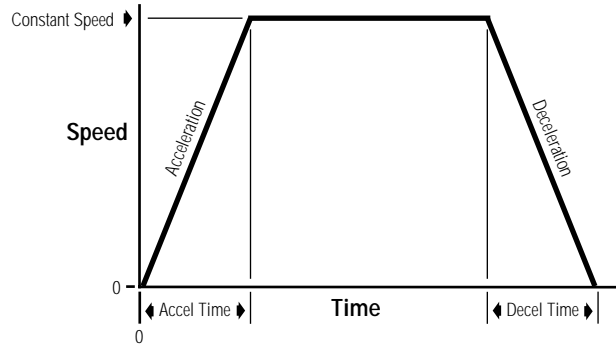
Important: Please note the resolution and Maximum Value changes with Frn 4.01.

[Base Frequency]**[Base Voltage]****[Maximum Voltage]**

These parameters were moved to the "Motor Control" group in firmware version 4.01. Refer to page 5-53 for parameter descriptions.

Setup

Accel/Decel Time



[Minimum Freq]	Parameter Number	16
	Parameter Type	Read and Write
	Display Units / Drive Units	1 Hertz / Hertz x 10 (x 1 frn < 4.01)
	Factory Default	0 Hz
	Minimum Value	0 Hz
	Maximum Value	120 Hz
Important: Please note the resolution change with Frn 4.01.		

[Maximum Freq]	Parameter Number	19
	Parameter Type	Read and Write
	Display Units / Drive Units	1 Hertz / Hertz x 10 (x 1 frn < 4.01)
	Factory Default	60 Hz
	Minimum Value	25 Hz
	Maximum Value	400 Hz
Important: Please note the resolution change with Frn 4.01.		

[Stop Select 1]	Parameter Number	10	
	Parameter Type	Read and Write	
	Factory Default	"Coast"	
	Units	Display Drive	
		"Coast" 0	Causes the drive to turn off immediately.
		"DC Brake" 1	Injects DC braking voltage into the motor. Requires a value in both [DC Hold Time] & [DC Hold Level].
	"Ramp" 2	Drive decelerates to 0 Hz., then if [DC Hold Time] & [DC Hold Level] are greater than zero the holding brake is applied. If the values equal zero, then the drive turns off. Requires a value in [Decel Time 1] or [Decel Time 2].	
	"S Curve" 3	Drive causes S Curve Ramp to 0 Hz in [Decel Time 1] or [Decel Time 2] x 2.	
	"Ramp to Hold" 4	Drive decelerates to zero Hertz then injects holding brake per [DC Hold Level] (limited to 70% of drive rated amps) until a) a Start command is issued or b) the Enable input is opened.	

[Current Limit]	Parameter Number	36
	Parameter Type	Read and Write
	Display Units / Drive Units	1% of Max Drive Output Current / 4096 = 100%
	Factory Default	150%
	Minimum Value	20% of [Rated Amps]
	Maximum Value	160% of [Rated Amps]

Setup

[Current Lmt Sel] – Firmware 4.01 & later

Selects the source of the [Current Limit] setting for the drive. When an external input is selected (0-10V or 4-20 mA), the minimum signal (0V or 4 mA) sets 20% current limit and the maximum signal (10V or 20mA) sets the value programmed in [Current Limit].

This parameter cannot be changed while the drive is running.

Parameter Number	232
Parameter Type	Read and Write
Factory Default	"Current Lmt"
Units	Display Drive
	"Current Lmt" 0 Use [Current Limit], param. 36.
	"0-10 Volt" 1 Adjustable through 10V input, TB2, 4 & 5.
	"4-20 mA" 2 Adjustable through 4-20mA input, TB2, 4 & 6.

[Adaptive I Lim] – Firmware 4.01 & later

When ENABLED, this parameter maintains normal current limit control to provide normal acceleration into medium to high system inertia.

When DISABLED, this parameter applies a feed forward command to acceleration, allowing quicker accel times from stopped to commanded speed with low system inertia.

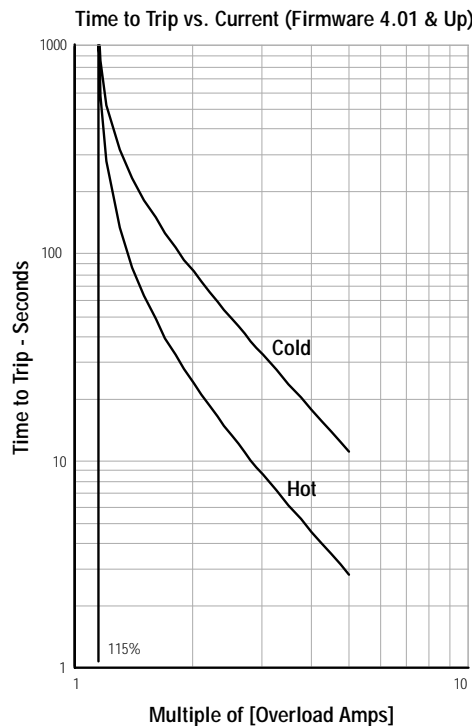
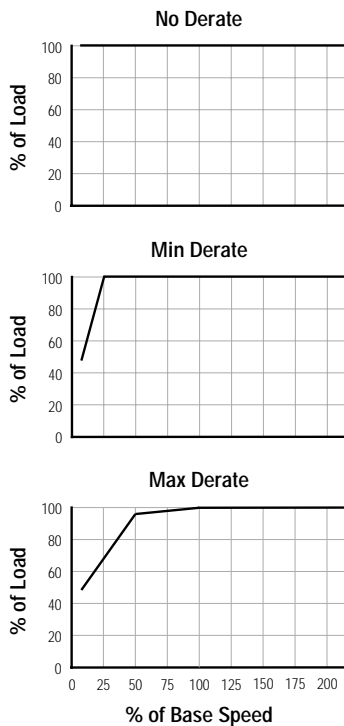
Parameter Number	227
Parameter Type	Read and Write
Factory Default	"Enabled"
Units	Display Drive
	"Disabled" 0
	"Enabled" 1

[Overload Mode]

This parameter selects the derating factor for the I²T electronic overload function. Motors designed to operate with wider speed ranges need less overload derating.

Parameter Number	37
Parameter Type	Read and Write
Factory Default	"No Derate" ("Max Derate" frn < 4.01)
Units	Display Drive
	"Max Derate" 2 2:1 Speed Range Derate below 50% of Base Speed
	"Min Derate" 1 4:1 Speed Range. Derate below 25% of Base Speed
	"No Derate" 0 10:1 Speed Range. No Derating

Overload Patterns



Setup

[Overload Amps]	Parameter Number	38
	Parameter Type	Read and Write
This value should be set to the motor nameplate Full Load Amps (FLA) for 1.15 SF motors. For 1.0 SF motors the value should be set to 0.9 x nameplate FLA.	Display Units / Drive Units	0.1 Amps / 4096 = Rated Amps
	Factory Default	115% of Drive Rating
	Minimum Value	20% of Drive Rated Amps
	Maximum Value	115% of Drive Rated Amps
<hr/>		
[VT Scaling]	Parameter Number	203
	Parameter Type	Read and Write
This parameter scales the drive for VT ampere ratings.	Factory Default	"Disabled"
	Units	Display Drive
This parameter cannot be changed while the drive is running.	"Disabled"	0 <i>Disables Variable Torque Scaling</i>
	"Enabled"	1 <i>Enables Variable Torque Scaling</i>
<hr/>		
[Motor NP RPM]	Parameter Number	177
	Parameter Type	Read and Write
This value should be set to the motor nameplate rated RPM.	Display Units / Drive Units	1 RPM / 1 RPM
	Factory Default	1750 RPM
This parameter cannot be changed while the drive is running.	Minimum Value	60 RPM
	Maximum Value	24000 RPM
<hr/>		
[Motor NP Hertz]	Parameter Number	178
	Parameter Type	Read and Write
This value should be set to the motor nameplate rated frequency.	Display Units / Drive Units	1 Hertz / Hertz x 10 (x 1 frn < 4.01)
	Factory Default	60 Hz
This parameter cannot be changed while the drive is running.	Minimum Value	1 Hz
	Maximum Value	400 Hz
<hr/>		
[Motor NP Volts]– Firmware 4.01 & later	Parameter Number	190
	Parameter Type	Read and Write
This value should be set to the motor nameplate rated volts.	Display Units / Drive Units	1 Volt / 4096 = Drive Rated Volts
	Factory Default	Drive Rated Volts
This parameter cannot be changed while the drive is running.	Minimum Value	0 Volts
	Maximum Value	2 x Drive Rated Volts
<hr/>		
[Motor NP Amps]– Firmware 4.01 & later	Parameter Number	191
	Parameter Type	Read and Write
This value should be set to the motor nameplate rated current.	Display Units / Drive Units	1 Amp / 4096 = Drive Rated Amps
	Factory Default	Drive Rated Amps
This parameter cannot be changed while the drive is running.	Minimum Value	0 Amps
	Maximum Value	2 x Drive Rated Amps

Advanced Setup

This group contains parameters that are required to setup advanced functions of the drive for complex applications.

[Minimum Freq]

This parameter sets the lowest frequency the drive will output.

Parameter Number	16
Parameter Type	Read and Write
Display Units / Drive Units	1 Hertz / Hertz x 10 (x 1 frn < 4.01)
Factory Default	0 Hz
Minimum Value	0 Hz
Maximum Value	120 Hz

Important: Please note the resolution change with Frn 4.01.

[Maximum Freq]

This parameter sets the highest frequency the drive will output.

This parameter cannot be changed while the drive is running.

Parameter Number	19
Parameter Type	Read and Write
Display Units / Drive Units	1 Hertz / Hertz x 10 (x 1 frn < 4.01)
Factory Default	60 Hz
Minimum Value	25 Hz
Maximum Value	400 Hz

Important: Please note the resolution change with Frn 4.01.

[Base Frequency]

[Base Voltage]

[Break Frequency]

[Break Voltage]

[Maximum Voltage]

These parameters were moved to the "Motor Control" group in firmware version 4.01. Refer to pages 5-52 and 5-53 for parameter descriptions.

[DC Boost Select] – Firmware below 4.01

This parameter sets the level of DC Boost that will be applied at low frequencies (typically 0-7 Hz). Auto settings automatically measure motor resistance and adjust the boost voltage to maintain constant boost performance regardless of changing motor temperature.

If this boost voltage (typically used for faster acceleration) is excessive for constant low speed operation, it can be automatically reduced to acceptable levels by programming [Run/Accel Boost].

Refer to the diagram on page 5-51 for further information.

Parameter Number	9
Parameter Type	Read and Write
Factory Default	"Auto 30%"
Units	Display Drive
	"Fan Sel #1" 0 see "Fan Select 1 & 2/No Boost" drawing below
	"Fan Sel #2" 1 see "Fan Select 1 & 2/No Boost" drawing below
	"No Boost" 2 see "Fan Select 1 & 2/No Boost" drawing below
	"Auto 15%" 3 minimum auto boost
	"Auto 30%" 4 .
	"Auto 45%" 5 .
	"Auto 60%" 6 .
	"Auto 75%" 7 .
	"Auto 90%" 8 .
	"Auto 105%" 9 .
	"Auto 120%" 10 maximum auto boost
	"Full Custom" 11 see "Full Custom" drawing below
	"Fixed" 12 see "Fixed" drawing below

[Start Boost]

[Run Boost]

These parameters were moved to the "Motor Control" group in firmware version 4.01. Refer to page 5-52 for parameter descriptions.

Advanced Setup

[Run/Accel Boost] – Firmware below 4.01

Sets the percentage of Auto Boost that is applied to the motor during constant speed or decel. If Auto Boost is selected in the [DC Boost Select] parameter (see preceding page), boost is applied as shown in the adjacent chart.

Parameter Number	169
Parameter Type	Read and Write
Display Units / Drive Units	1%
Factory Default	100%
Minimum Value	0%
Maximum Value	100%
Drive Mode	Auto Boost Applied
Accelerating	Programmed Auto Boost %
Constant Speed	Programmed Auto Boost % x [Run/Accel Boost]
Decelerating	Programmed Auto Boost % x [Run/Accel Boost]

[PWM Frequency]

This parameter sets the carrier frequency for the sine coded PWM output waveform.
 This parameter cannot be changed while the drive is running.
 Refer to page 1-1 for Frame Reference information and the Derating Guidelines in Appendix A.

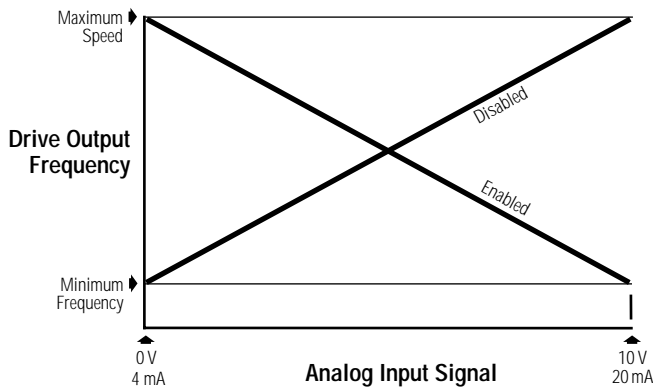
Parameter Number	45
Parameter Type	Read and Write
Display Units / Drive Units	2 KHz / KHz/2
Factory Default	Based on drive type
Minimum Value	2 KHz
Maximum Value	A Frame Drives = 10 kHz B Frame Drives = 8 kHz C Frame Drives & Up = 6 kHz

[Analog Invert] – Firmware below 4.01

This parameter enables the inverting function for the analog input signal at TB2.
 This parameter cannot be changed while the drive is running.

Parameter Number	84
Parameter Type	Read and Write
Factory Default	"Disabled"
Units	Display Drive
	"Disabled" 0
	"Enabled" 1

Analog Invert



[Analog Trim En]

This parameter enables the pot terminals at TB2, terminals 1, 2 & 3 as a trim function to the analog inputs at TB2 terminals 4 & 5 or 4 & 6. A 10k ohm pot provides a trim range of approximately 10% of [Maximum Freq]. Drive status must be "Stopped" before programming changes will take effect.

Parameter Number	90
Parameter Type	Read and Write
Factory Default	"Disabled"
Units	Display Drive
	"Disabled" 0
	"Enabled" 1

Advanced Setup

[4-20mA Loss Sel]

This parameter selects the drives reaction to a loss of 4-20mA signal when the active [Freq Source] is 4-20mA.

Parameter Number	150
Parameter Type	Read and Write
Factory Default	"Min/Alarm"
Units	Display Drive
	"Min/Alarm" 0 Drive outputs [Minimum Freq] and issues an alarm.
	"Stop/Fault" 1 Drive stops and issues "Hertz Err Fault".
	"Hold/Alarm" 2 Drive maintains last output freq and issues an alarm.
	"Max/Alarm" 3 Drive outputs [Maximum Freq] and issues an alarm.
	"Pre1/Alarm" 4 Drive outputs [Preset Freq 1] and issues an alarm.

[Accel Time 2]

This value determines the time it will take the drive to ramp from 0 Hz to [Maximum Freq]. The rate determined by this value and [Maximum Freq] is linear unless [S Curve Enable] is "Enabled." It applies to any increase in command frequency unless [Accel Time 1] is selected.

Parameter Number	30
Parameter Type	Read and Write
Display Units / Drive Units	0.1 Second / Seconds x 10 (x 100 frn < 4.01)
Factory Default	10.0 Sec
Minimum Value	0.0 Sec
Maximum Value	3600.0 Sec (600.0 frn < 4.01)
Important: Please note the resolution and Maximum Value changes with Frn 4.01.	

[Decel Time 2]

This value determines the time it will take the drive to ramp from [Maximum Freq] to 0 Hz. The rate determined by this value and [Maximum Freq] is linear unless [S Curve Enable] is "Enabled." It applies to any decrease in command frequency unless [Decel Time 1] is selected.

Parameter Number	31
Parameter Type	Read and Write
Display Units / Drive Units	0.1 Second / Seconds x 10 (x 100 frn < 4.01)
Factory Default	10.0 Sec
Minimum Value	0.0 Sec
Maximum Value	3600.0 Sec (600.0 frn < 4.01)
Important: Please note the resolution and Maximum Value changes with Frn 4.01.	

[Stop Select 1]

This parameter selects the stopping mode when the drive receives a valid stop command unless [Stop Select 2] is selected.

Parameter Number	10
Parameter Type	Read and Write
Factory Default	"Coast"
Units	Display Drive
	"Coast" 0 Causes the drive to turn off immediately.
	"DC Brake" 1 Injects DC braking voltage into the motor. Requires a value in both [DC Hold Time] & [DC Hold Level].
	"Ramp" 2 Drive decelerates to 0 Hz., then if [DC Hold Time] & [DC Hold Level] are greater than zero the holding brake is applied. If the values equal zero, then the drive turns off. Requires a value in [Decel Time 1] or [Decel Time 2].
	"S Curve" 3 Drive causes S Curve Ramp to 0 Hz in [Decel Time 1] or [Decel Time 2] x 2.
	"Ramp to Hold" 4 Drive decelerates to zero Hertz then injects holding brake per [DC Hold Level] (limited to 70% of drive rated amps) until a) a Start command is issued or b) the Enable input is opened.

Advanced Setup

[DC Hold Time]

This value sets the amount of time that the [DC Hold Level] voltage will be applied to the motor when the stop mode is set to either "DC Brake" or "Ramp."

Parameter Number	12
Parameter Type	Read and Write
Display Units / Drive Units	1 Second / Seconds x 10 (x 1 frn < 4.01)
Factory Default	0.0 Sec (0 frn < 4.01)
Minimum Value	0.0 Sec (0 frn < 4.01)
Maximum Value	90.0 Sec (15 frn < 4.01)

Important: Please note the resolution and value changes with Frn 4.01.

[DC Hold Level]

This value sets the DC voltage applied to the motor to produce the selected current during braking, when the stop mode is set to either "DC Brake," "Ramp" or "Ramp to Hold." If "Ramp to Hold" is the active stop mode, [DC Hold Level] will be clamped at 70%, even if higher values are programmed.

Parameter Number	13
Parameter Type	Read and Write
Display Units / Drive Units	1 % of [Rated Amps] / 4096 = 100%
Factory Default	100 %
Minimum Value	0 %
Maximum Value	150 %



ATTENTION: If a hazard of injury due to movement of equipment or material exists, an auxiliary mechanical braking device must be used to stop the motor.

ATTENTION: This feature should not be used with synchronous or permanent magnet motors. Motors may be demagnetized during braking.

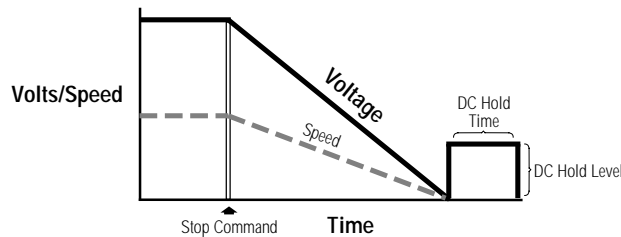
[Hold Level Sel]– Firmware 4.01 & later

This parameter selects the hold level source for [DC Hold Level].

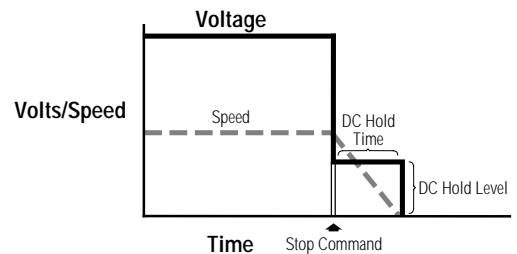
This parameter cannot be changed while the drive is running.

Parameter Number	231
Parameter Type	Read and Write
Factory Default	"DC Hold Lvl"
Units	Display / Drive
	"DC Hold Lvl" 0 Use [DC Hold Level], param. 13.
	"0-10 Volt" 1 Adjustable through 10V input, TB2, 4 & 5.
	"4-20 mA" 2 Adjustable through 4-20mA input, TB2, 4 & 6.

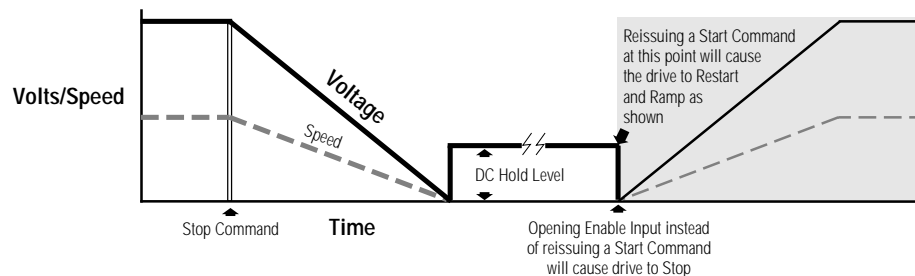
Ramp-to-Stop



Brake-to-Stop



Ramp-to-Hold



Advanced Setup

[Bus Limit En]

Enables the function that attempts to limit the drive DC bus voltage to 110% of nominal voltage during rapid decel. If bus voltage rises above the 110% level, [BUS Limit En] reduces or stops the drive decel rate until bus voltage falls below the 110% level.

Parameter Number	11
Parameter Type	Read and Write
Factory Default	"Disabled"
Units	Display Drive
	"Disabled" 0 <i>Allow bus voltage to rise above 110%.</i>
	"Enabled" 1 <i>Limit bus voltage/decel ramp.</i>

[Motor Type]

This parameter should be set to match the type of motor connected to the drive.

Parameter Number	41
Parameter Type	Read and Write
Factory Default	"Induction"
Units	Display Drive
	"Induction" 0 <i>Requires no additional setting.</i>
	"Sync Reluc" 1 <i>[Slip @ F.L.A.] must be set to zero.</i>
	"Sync PM" 2 <i>[Stop Select 1 & 2] must be set to a selection other than "DC Brake" and [Slip @ F.L.A.] be set to zero.</i>

[Stop Select 2]

This parameter selects the stopping mode when the drive receives a valid stop command unless [Stop Select 1] is selected.

Parameter Number	52
Parameter Type	Read and Write
Factory Default	"Coast"
Units	Display Drive
	"Coast" 0 <i>Causes the drive to turn off immediately.</i>
	"DC Brake" 1 <i>Injects DC braking voltage into the motor. Requires a value in both [DC Hold Time] & [DC Hold Level].</i>
	"Ramp" 2 <i>Drive decelerates to 0 Hz., then if [DC Hold Time] & [DC Hold Level] are greater than zero the holding brake is applied. If the values equal zero, then the drive turns off. Requires a value in [Decel Time 1] or [Decel Time 2].</i>
	"S Curve" 3 <i>Drive causes S Curve Ramp to 0 Hz in [Decel Time 1] or [Decel Time 2] x 2.</i>
	"Ramp to Hold" 4 <i>Drive decelerates to zero Hertz then injects holding brake per [DC Hold Level] (limited to 70% of drive rated amps) until a) a Start command is issued or b) the Enable input is opened.</i>

[KI Amps] – Firmware 2.03-3.01

Sets the integral gain for the current limiting function of the drive. Default values are chosen for high inertia loads. If faster accel is required, raising the gain will allow additional current to the motor. Excess gain settings may create unstable operation.

Important: [Kp Amps] should be adjusted in equal proportion or unstable operation may occur.

Parameter Number	192
Parameter Type	Read and Write
Display Units / Drive Units	NA / NA
Factory Default	100
Minimum Value	25
Maximum Value	800

[KP Amps]

Sets the proportional gain for the current limiting function of the drive. Default values are chosen for high inertia loads. If faster accel is required, raising the gain will allow additional current to the motor. Excess gain settings may create unstable operation.

Parameter Number	193
Parameter Type	Read and Write
Display Units / Drive Units	NA / NA
Factory Default	100
Minimum Value	25
Maximum Value	400 (800 frn < 3.01)

Frequency Set

This group of parameters contains internally stored frequency settings.

[Freq Select 1]

This parameter controls which of the frequency sources is currently supplying the [Freq Command] to the drive unless [Freq Select 2] or [Preset Freq 1-7] is selected. Refer to the *Speed Select Input* Table in Chapter 2.

Parameter Number	5	
Parameter Type	Read and Write	
Factory Default	"Adapter 1"	
Units	Display	Drive
	"Adapter 1"	6
	"Adapter 2"	7
	"Adapter 3"	8
	"Adapter 4"	9
	"Adapter 5"	10
	"Adapter 6"	11
	"Preset 1-7"	12-18
	"Use Last"	0
	"Remote Pot"	1
	"0-10 Volt"	2
	"4-20 mA"	3
	"Pulse Ref"	4 Refer to [Pulse/Enc Scale] Scale Value
	"MOP"	5

[Freq Select 2]

This parameter controls which of the frequency sources is currently supplying the [Freq Command] to the drive unless [Freq Select 1] or [Preset Freq 1-7] is selected. Refer to the *Speed Select Input* Table in Chapter 2.

Parameter Number	6	
Parameter Type	Read and Write	
Factory Default	"Preset 1"	
Units	Display	Drive
	"Adapter 1"	6
	"Adapter 2"	7
	"Adapter 3"	8
	"Adapter 4"	9
	"Adapter 5"	10
	"Adapter 6"	11
	"Preset 1-7"	12-18
	"Use Last"	0
	"Remote Pot"	1
	"0-10 Volt"	2
	"4-20 mA"	3
	"Pulse Ref"	4 Refer to [Pulse/Enc Scale] Scale Value
	"MOP"	5

[Jog Frequency]

This parameter sets the frequency the drive will output when it receives a valid jog command.

Parameter Number	24
Parameter Type	Read and Write
Display Units / Drive Units	0.1 Hertz / Hertz x 100
Factory Default	10.0 Hz
Minimum Value	0.0 Hz
Maximum Value	400.0 Hz

[Preset Freq 1-7]

These values set the frequencies that the drive will output when selected. Refer to *Speed Select Input* table in Chapter 2.

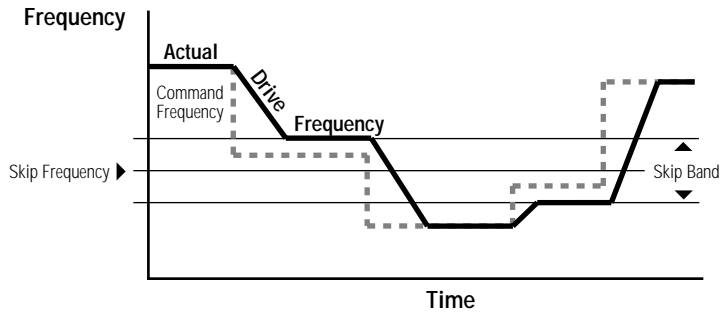
Parameter Number(s)	27-29 & 73-76
Parameter Type	Read and Write
Display Units / Drive Units	0.1 Hertz / Hertz x 100
Factory Default	0.0 Hz
Minimum Value	0.0 Hz
Maximum Value	400.0 Hz

Frequency Set

[Skip Freq 1-3] These values, in conjunction with [Skip Freq Band], create a range of frequencies at which the drive will not continuously operate.	Parameter Number(s)	32-34
	Parameter Type	Read and Write
	Display Units / Drive Units	1 Hertz / Hertz
	Factory Default	400 Hz
	Minimum Value	0 Hz
	Maximum Value	400 Hz

[Skip Freq Band] This parameter determines the band width around a [Skip Frequency]. The actual band width is 2 x [Skip Freq Band] — 1/2 the band above and 1/2 the band below the skip frequency.	Parameter Number	35
	Parameter Type	Read and Write
	Display Units / Drive Units	1 Hertz / Hertz
	Factory Default	0 Hz
	Minimum Value	0 Hz
	Maximum Value	15 Hz

Skip Frequency Band



[MOP Increment] This value sets the rate of increase or decrease to the [Freq Command] for each input to the Dig Pot Up or Dig Pot Down terminals at TB3 — Requires [Input Mode] selection 5, 9, 10 or 15 (see Input Mode Selection figure in Chapter 2), RIO Adapter or other SCANport adapter to function.	Parameter Number	22
	Parameter Type	Read and Write
	Display Units / Drive Units	0.1 Hertz/Second / 255 = (78% of [Maximum Freq])/Sec
	Factory Default	1.1 Hz/Sec
	Minimum Value	0 Hz/Sec
	Maximum Value	(78% of [Maximum Freq]) / Sec

[Save MOP Ref] – Firmware 4.01 & later If this parameter is enabled, the frequency command issued by the MOP inputs will be saved to EEPROM (in the event of power loss) and reused on power up. When disabled, no value is saved and the MOP reference is reset to zero on power up.	Parameter Number	230
	Parameter Type	Read and Write
	Factory Default	“Disabled”
	Units	Display Drive
		“Disabled” 0
		“Enabled” 1

[Freq Ref SqRoot] – Firmware 4.01 & later This parameter activates the square root function for 0-10V or 4-20 mA inputs when used as a frequency reference. If the input signal varies with the square of speed, the parameter should be set to “Enabled.”	Parameter Number	229
	Parameter Type	Read and Write
	Factory Default	“Disabled”
	Units	Display Drive
		“Disabled” 0
		“Enabled” 1

Frequency Set

[Pulse/Enc Scale]

This parameter contains the scaling factor for both pulse train inputs (TB2-7, 8) and encoder feedback speed regulation (TB3 terminals 31-36).

1. Encoder Feedback Operation
Enter actual encoder pulses per revolution

2. Pulse Train Input

$$\text{Scale Factor} = \frac{\text{Incoming Pulse Rate (Hz)}}{\text{Desired Command Freq.}} \times \frac{\text{Motor Poles}}{2}$$

Parameter Number	46
Parameter Type	Read and Write
Display Units / Drive Units	Factor / Pulses per Rev
Factory Default	1024 PPR (64 PPR frn < 4.01)
Minimum Value	1
Maximum Value	4096

Pulse Train Example:
4 Pole Motor, 60 Hz = Max. Speed.
The 1336-MOD-N1 option outputs 64 Hz/Hz.
At full analog reference, the pulse output will be 60 Hz x 64 Hz/Hz = 3840 pulses/sec.

$$\text{Pulse/Enc Scale} = \frac{3840 \text{ Hz}}{60 \text{ Hz}} \times \frac{4 \text{ Poles}}{2} = 128$$

This value will create a command frequency of 60 Hz for full analog reference to the option.

Feature Select

This group contains the necessary parameters to activate and program advanced features of the drive.

[Dwell Frequency]

This value sets the frequency that the drive will immediately output (no Accel Ramp) upon a start command. This parameter requires a programmed [Dwell Time].

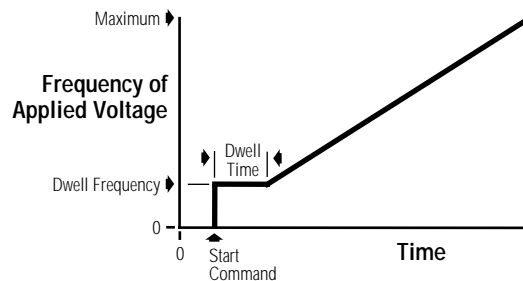
Parameter Number	43
Parameter Type	Read and Write
Display Units / Drive Units	0.1 Hertz / Hertz x 10
Factory Default	0.0 Hz
Minimum Value	0.0 Hz
Maximum Value	7.0 Hz

[Dwell Time]

This value sets the time the drive will continue to output [Dwell Frequency] before ramping to [Freq Command].

Parameter Number	44
Parameter Type	Read and Write
Display Units / Units	1 Second / Seconds
Factory Default	0 Sec
Minimum Value	0 Sec
Maximum Value	10 Sec

Dwell Time



Feature Select

[Speed Control]

This parameter selects the type of speed modulation active in the drive.

This parameter cannot be changed while the drive is running.

Important: If encoder feedback closed loop speed regulation is required, "Encoder Fdbk" must be selected.

Parameter Number	77
Parameter Type	Read and Write
Factory Default	"Slip Comp" ("No Control" frn < 4.01)
Units	Display Drive
	"No Control" 0 <i>Frequency regulation</i>
	"Slip Comp" 1 <i>Slip compensation</i>
	"Speed Droop" 2 <i>Negative slip compensation</i>
	"PLL" 3 <i>Phase lock loop (requires frn < 4.01)</i>
	"Encoder Fdbk" 4 <i>Encoder feedback-closed loop</i>
	"Droop + Reg" 5 <i>Enc. fdbk-closed loop w/ active droop</i>
	"P Jump" 6 <i>Traverse function</i>
	"Process PI" 7 <i>Closed loop PI control</i>

[Slip @ F.L.A.]

This value sets the amount of automatic increase or decrease to the drive output to compensate for motor slip. When [Speed Control] is set to "Slip Comp", a percentage of this value proportional to output current is added to the drive output frequency. When [Speed Control] is set to "Droop", a percentage of this value proportional to output current is subtracted from the drive output frequency.

Parameter Number	42
Parameter Type	Read and Write
Display Units / Drive Units	0.1 Hertz / Hertz x 10
Factory Default	1.0 Hz (0.0 Hz frn < 4.01)
Minimum Value	0.0 Hz
Maximum Value	10.0 Hz (5.0 frn < 4.01)

[Slip Comp Gain]– Firmware 4.01 & later

This parameter is the gain for the slip compensation and adjusts the recovery rate after a load change.

Parameter Number	195
Parameter Type	Read and Write
Display Units / Drive Units	None
Factory Default	1
Minimum Value	1
Maximum Value	40

[Run On Power Up]

This parameter enables the function that allows the drive to automatically restart on Power Up. This parameter requires that a two wire control scheme be installed at TB3 and that a valid start contact be present. Refer to *Input Mode Selection* figure in Chapter 2.

Parameter Number	14
Parameter Type	Read and Write
Factory Default	"Disabled"
Units	Display Drive
	"Disabled" 0
	"Enabled" 1



ATTENTION: This parameter may only be used as outlined in NFPA79, paragraph 6-14 (exceptions 1-3) for specialized applications. Equipment damage and/or personal injury may result if this parameter is used in an inappropriate application.

[Reset/Run Tries]

This value sets the maximum number of times the drive attempts to reset a fault and restart before the drive issues a "Max Retries Fault". See Chapter 6 for a list of resettable faults.

Parameter Number	85
Parameter Type	Read and Write
Display Units / Drive Units	1 Try / Tries
Factory Default	0
Minimum Value	0
Maximum Value	9

Feature Select

[Reset/Run Time]

This value sets the time between restart attempts when [Reset/Run Tries] is set to a value other than zero.

Parameter Number	15
Parameter Type	Read and Write
Display Units / Drive Units	0.1 Second / Seconds x 100
Factory Default	1.0 Sec
Minimum Value	0.5 Sec
Maximum Value	30.0 Sec

[S Curve Enable]

This parameter enables the fixed shape S curve accel/decel ramp. Programmed accel/decel times are doubled if [S Curve Time] is set to "0". An adjustable S curve will be created if [S Curve Time] is greater than zero.

Parameter Number	57
Parameter Type	Read and Write
Factory Default	"Disabled"
Units	Display Drive
	"Disabled" 0
	"Enabled" 1

[S Curve Time]

This creates an adjustable s curve ramp. If S Curve Time is < the programmed accel/decel time, the actual ramp will be the sum of the two. If S Curve Time is ≥ the programmed accel/decel times, a fixed S curve will be created whose time is double the programmed accel/decel time.

Parameter Number	56
Parameter Type	Read and Write
Display Units / Drive Units	0.1 Second / Seconds x 10 (x 100 frn < 4.01)
Factory Default	0.0 Sec
Minimum Value	0.0 Sec
Maximum Value	1800.0 Sec (300.0 frn < 4.01)

Important: Please note the resolution and Maximum Value changes with Frn 4.01.

Fixed S Curve

Accel Time = 2 x [Accel Time 1 or 2]
 Decel Time = 2 x [Decel Time 1 or 2]

Adjustable S Curve

Case 1 (see adjacent diagram)

[S Curve Time] < [Accel Time 1 or 2], and
 [S Curve Time] < [Decel Time 1 or 2],
 then

Accel Time = [Accel Time 1 or 2] + [S Curve Time],
 and

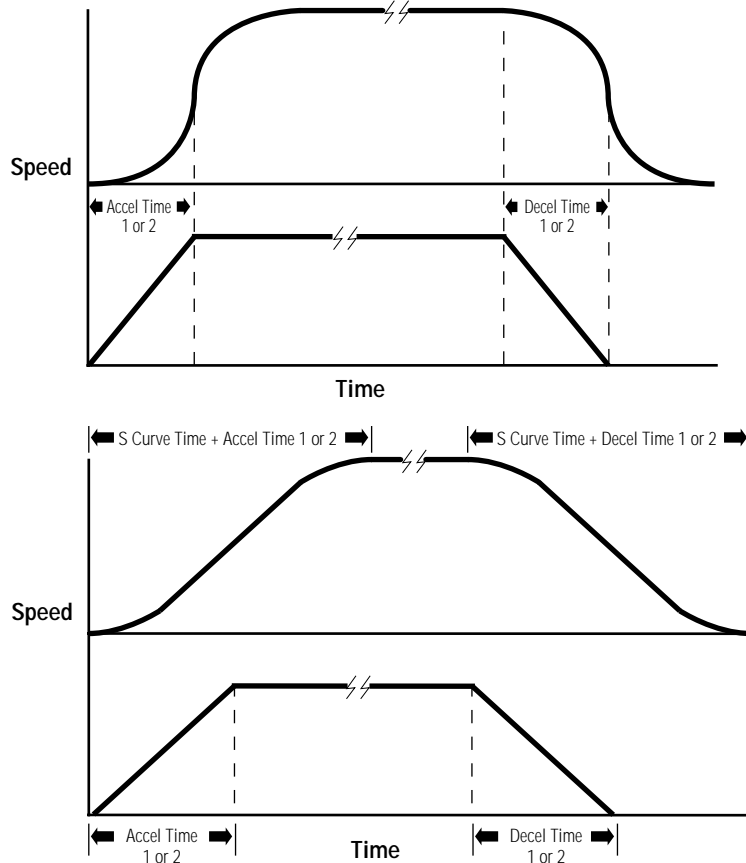
Decel Time = [Decel Time 1 or 2] + [S Curve Time]

Case 2

[S Curve Time] ≥ [Accel Time 1 or 2], and
 [S Curve Time] ≥ [Decel Time 1 or 2],
 then

Accel Time = 2 x [Accel Time 1 or 2], and
 Decel Time = 2 x [Decel Time 1 or 2]

Note: If [S Curve Time] ≥ programmed accel/decel times any further increase in [S Curve Time] will have no effect on the total accel/decel times.



Feature Select

[Language] This parameter selects between English and the alternate language for the HIM display.	Parameter Number	47	
	Parameter Type	Read and Write	
	Factory Default	"English"	
	Units	Display	Drive
		"English"	0
		"Alternate"	1

[Speed Control] This parameter is now located earlier in this group (effective with firmware version 4.01). Refer to page 5-22 for parameter description.

[Flying Start En] This value enables the flying start function and chooses the method to be used. The drive will first search from the direction it was last running.	Parameter Number	155	
	Parameter Type	Read and Write	
	Factory Default	Disabled	
	Units	Display	Drive
		"Disabled"	0
	"Speed Search"	1	<i>Freq. sweep –see [FStart For./Rev.]</i>
	"Use Encoder"	2	<i>Requires feedback encoder</i>
	"Track Volts"	3	<i>Read back EMF from sync. p.m. motor</i>



ATTENTION: The "Speed Search" selection should not be used with synchronous or permanent magnet motors. Motors may be demagnetized during braking.

[FStart Forward] This value sets the frequency at which the forward speed search begins. If this value exceeds [Maximum Freq], speed search will begin at [Maximum Freq]. Forward search ends at zero Hertz or when motor speed is found.	Parameter Number	156	
	Parameter Type	Read and Write	
	Display Units / Drive Units	1 Hertz / Hertz	
	Factory Default	60 Hz	
	Minimum Value	0 Hz	
	Maximum Value	400 Hz	

[FStart Reverse] This value sets the frequency at which the reverse speed search begins. If this value exceeds [Maximum Freq], speed search will begin at [Maximum Freq]. Reverse search ends at zero Hertz or when motor speed is found.	Parameter Number	157	
	Parameter Type	Read and Write	
	Display Units / Drive Units	1 Hertz / Hertz	
	Factory Default	0 Hz	
	Minimum Value	0 Hz	
	Maximum Value	400 Hz	

[LLoss Restart] – Firmware 4.01 & later This parameter selects the reconnect mode after recovery from a line loss condition.	Parameter Number	228	
	Parameter Type	Read and Write	
	Factory Default	"Track Volts"	
	Units	Display	Drive
		"Speed Search"	1
	"Use Encoder"	2	<i>Read feedback</i>
	"Track Volts"	3	<i>Read motor volts</i>
	"Last Speed"	4	<i>Start at last output</i>

Feature Select

[Traverse Period]

This value sets the time to complete one cycle of speed modulation.

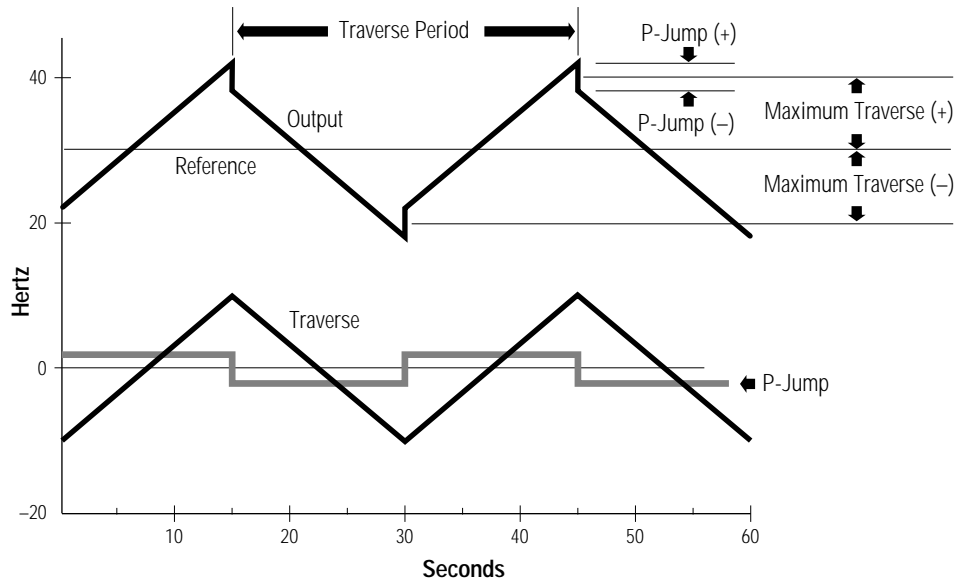
Parameter Number	78
Parameter Type	Read and Write
Display Units / Drive Units	0.01 Second / Seconds x 100
Factory Default	0.00 Sec
Minimum Value	0.00 Sec
Maximum Value	30.00 Sec

[Max Traverse]

This value sets the peak amplitude of speed modulation.

Parameter Number	79
Parameter Type	Read and Write
Display Units / Drive Units	0.01 Hertz / 32767 = [Maximum Freq]
Factory Default	0.00 Hz
Minimum Value	0.00 Hz
Maximum Value	50% of [Maximum Freq]

Traverse Function



[P Jump]

This value sets the slip or inertia compensation amplitude of speed modulation.

Parameter Number	80
Parameter Type	Read and Write
Display Units / Drive Units	0.01 Hertz / 32767 = [Maximum Freq]
Factory Default	0.00 Hz
Minimum Value	0.00 Hz
Maximum Value	25% of [Maximum Freq]

I/O Config

This group of parameters contains the programming options for digital and analog drive outputs. This group was named "Output Config" in firmware versions before 4.01.

[Input Mode]

This parameter selects the functions of inputs 1-8 at TB3 when an optional interface card is installed. Refer to *Input Mode Selection* figure in Chapter 2. This parameter cannot be changed while the drive is running. Power to the drive must be cycled before any changes will affect drive operation.

Parameter Number	21
Parameter Type	Read and Write
Display Units / Drive Units	Mode Number / Selection
Factory Default	1
Minimum Value	1
Maximum Value	24

[CR1-4 Out Select] – Firmware 4.01 & later

This parameter sets the condition that changes the state of the output contacts at TB2 terminals 10 & 11 (CR1), 11 & 12 (CR2), 13, 14, 15 (CR3) and 16, 17, 18 (CR4).

A change of state may mean energize or de-energize the relay, since some relays may energize on power-up and de-energize when the selected condition occurs.

A red LED located on the Main Control Board indicates the status of the CR3 contact. The LED will illuminate when the contacts at terminals 13 & 14 of TB2 are closed and terminals 14 & 15 are open.

Parameter Number	158, 174-176																																				
Parameter Type	Read and Write																																				
Factory Default	"At speed" CR1 "Running" CR2 "Fault" CR3 "Alarm" CR4																																				
Units	<table> <thead> <tr> <th>Display</th> <th>Drive</th> </tr> </thead> <tbody> <tr> <td>"Running"</td> <td>2 <i>Outputting frequency</i></td> </tr> <tr> <td>"At Speed"</td> <td>3 <i>Output = command</i></td> </tr> <tr> <td>"At Freq"</td> <td>4 <i>Requires value in [Dig Out Freq]</i></td> </tr> <tr> <td>"At Current"</td> <td>5 <i>Requires value in [Dig Out Curr]</i></td> </tr> <tr> <td>"At Torque"</td> <td>6 <i>Requires value in [Dig Out Torque]</i></td> </tr> <tr> <td>"Current Lmt"</td> <td>7 <i>In overload</i></td> </tr> <tr> <td>"Mtr Overload"</td> <td>8 <i>At present levels O.L. will occur</i></td> </tr> <tr> <td>"Line Loss"</td> <td>9 <i>Line loss in progress</i></td> </tr> <tr> <td>"Drive Power"</td> <td>10 <i>Full input volts present, bus charged</i></td> </tr> <tr> <td>"Drive Ready"</td> <td>11 <i>All necessary commands present</i></td> </tr> <tr> <td>"Forward Run"</td> <td>12 <i>Forward direction</i></td> </tr> <tr> <td>"Reverse Run"</td> <td>13 <i>Reverse direction</i></td> </tr> <tr> <td>"Braking"</td> <td>14 <i>DC brake mode (stopping or holding)</i></td> </tr> <tr> <td>"Economize"</td> <td>15 <i>Auto economizer active</i></td> </tr> <tr> <td>"Auto Reset"</td> <td>16 <i>Attempt to reset fault & restart drive</i></td> </tr> <tr> <td>"Fault"</td> <td>0 <i>Any fault</i></td> </tr> <tr> <td>"Alarm"</td> <td>1 <i>Any unmasked alarm</i></td> </tr> </tbody> </table>	Display	Drive	"Running"	2 <i>Outputting frequency</i>	"At Speed"	3 <i>Output = command</i>	"At Freq"	4 <i>Requires value in [Dig Out Freq]</i>	"At Current"	5 <i>Requires value in [Dig Out Curr]</i>	"At Torque"	6 <i>Requires value in [Dig Out Torque]</i>	"Current Lmt"	7 <i>In overload</i>	"Mtr Overload"	8 <i>At present levels O.L. will occur</i>	"Line Loss"	9 <i>Line loss in progress</i>	"Drive Power"	10 <i>Full input volts present, bus charged</i>	"Drive Ready"	11 <i>All necessary commands present</i>	"Forward Run"	12 <i>Forward direction</i>	"Reverse Run"	13 <i>Reverse direction</i>	"Braking"	14 <i>DC brake mode (stopping or holding)</i>	"Economize"	15 <i>Auto economizer active</i>	"Auto Reset"	16 <i>Attempt to reset fault & restart drive</i>	"Fault"	0 <i>Any fault</i>	"Alarm"	1 <i>Any unmasked alarm</i>
Display	Drive																																				
"Running"	2 <i>Outputting frequency</i>																																				
"At Speed"	3 <i>Output = command</i>																																				
"At Freq"	4 <i>Requires value in [Dig Out Freq]</i>																																				
"At Current"	5 <i>Requires value in [Dig Out Curr]</i>																																				
"At Torque"	6 <i>Requires value in [Dig Out Torque]</i>																																				
"Current Lmt"	7 <i>In overload</i>																																				
"Mtr Overload"	8 <i>At present levels O.L. will occur</i>																																				
"Line Loss"	9 <i>Line loss in progress</i>																																				
"Drive Power"	10 <i>Full input volts present, bus charged</i>																																				
"Drive Ready"	11 <i>All necessary commands present</i>																																				
"Forward Run"	12 <i>Forward direction</i>																																				
"Reverse Run"	13 <i>Reverse direction</i>																																				
"Braking"	14 <i>DC brake mode (stopping or holding)</i>																																				
"Economize"	15 <i>Auto economizer active</i>																																				
"Auto Reset"	16 <i>Attempt to reset fault & restart drive</i>																																				
"Fault"	0 <i>Any fault</i>																																				
"Alarm"	1 <i>Any unmasked alarm</i>																																				

[Digital Out Sel] – Firmware below 4.01

This parameter sets the condition that closes the output contact at TB2 terminals 10 & 11.

Parameter Number	158										
Parameter Type	Read and Write										
Factory Default	"At Speed"										
Units	<table> <thead> <tr> <th>Display</th> <th>Drive</th> </tr> </thead> <tbody> <tr> <td>"At Speed"</td> <td>0</td> </tr> <tr> <td>"At Frequency"</td> <td>1 <i>Requires value in [Dig Out Freq]</i></td> </tr> <tr> <td>"At Current"</td> <td>2 <i>Requires value in [Dig Out Curr]</i></td> </tr> <tr> <td>"At Torque"</td> <td>3 <i>Requires value in [Dig Out Torque]</i></td> </tr> </tbody> </table>	Display	Drive	"At Speed"	0	"At Frequency"	1 <i>Requires value in [Dig Out Freq]</i>	"At Current"	2 <i>Requires value in [Dig Out Curr]</i>	"At Torque"	3 <i>Requires value in [Dig Out Torque]</i>
Display	Drive										
"At Speed"	0										
"At Frequency"	1 <i>Requires value in [Dig Out Freq]</i>										
"At Current"	2 <i>Requires value in [Dig Out Curr]</i>										
"At Torque"	3 <i>Requires value in [Dig Out Torque]</i>										

[Dig Out Freq]

This value sets the trip point for the output contact at TB2 terminals 10 & 11 when [Digital Out Sel] is set to "At Frequency". The contact will be closed when above this value.

Parameter Number	159
Parameter Type	Read and Write
Display Units / Drive Units	0.01 Hertz / 32767 = Max Freq
Factory Default	0.00 Hz
Minimum Value	0.00 Hz
Maximum Value	Programmed [Maximum Freq]

[Dig Out Current]

This value sets the trip point for the output contact at TB2 terminals 10 & 11 when [Digital Out Sel] is set to "At Current". The contact will be closed when above this value.

Parameter Number	160
Parameter Type	Read and Write
Display Units / Drive Units	0% / 4096 = 100% of Drive Rated Amps
Factory Default	0 %
Minimum Value	0 %
Maximum Value	200 %

I/O Config

[Dig Out Torque]

This value sets the trip point for the output contact at TB2 terminals 10 & 11 when [Digital Out Sel] is set to "At Torque". The contact will be closed when above this value.

Parameter Number	161
Parameter Type	Read and Write
Display Units / Drive Units	0.1 Amps / 4096 = Rated Torque Amps
Factory Default	0.0 Amps
Minimum Value	0.0 Amps
Maximum Value	200% of [Rated Amps]

[Set 0-10 Vlt Lo] – Firmware 4.01 & later

Sets the percentage of the 0-10 volt input that represents [Minimum Freq].

Parameter Number	237
Parameter Type	Read and Write
Display Units / Drive Units	0.1% / 4096 = 100%
Factory Default	0.0%
Minimum Value	-300.0%
Maximum Value	+300.0%

[Set 0-10 Vlt Hi] – Firmware 4.01 & later

Sets the percentage of the 0-10 volt input that represents [Maximum Freq].

Parameter Number	238
Parameter Type	Read and Write
Display Units / Drive Units	0.1% / 4096 = 100%
Factory Default	100.0%
Minimum Value	-300.0%
Maximum Value	+300.0%

[Set 4-20 mA Lo] – Firmware 4.01 & later

Sets the percentage of the 4-20 mA input that represents [Minimum Freq].

Parameter Number	239
Parameter Type	Read and Write
Display Units / Drive Units	0.1% / 4096 = 100%
Factory Default	0.0%
Minimum Value	-300.0%
Maximum Value	+300.0%

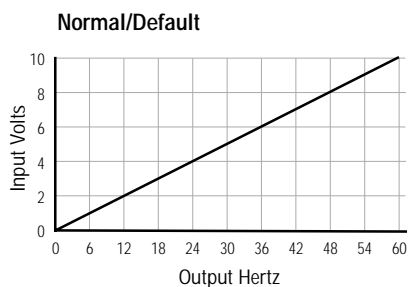
[Set 4-20 mA Hi] – Firmware 4.01 & later

Sets the percentage of the 4-20 mA input that represents [Maximum Freq].

Parameter Number	240
Parameter Type	Read and Write
Display Units / Drive Units	0.1% / 4096 = 100%
Factory Default	100.0%
Minimum Value	-300.0%
Maximum Value	+300.0%

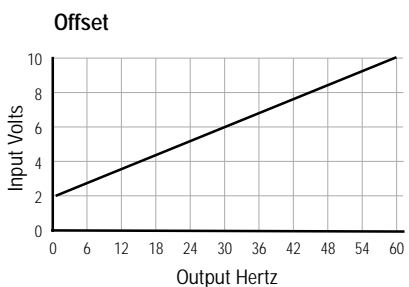
Analog Input Configuration

Examples shown are for 0-10V. Settings for 4-20 mA are similar.



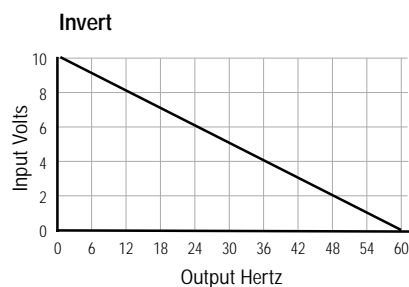
[Minimum Freq] = 0 Hz
 [Maximum Freq] = 60 Hz
 [Set 0-10 Vlt Lo] = 0%
 [Set 0-10 Vlt Hi] = 100%

Minimum input (0% of 10V=0V) represents minimum frequency of 0 Hz and maximum input (100% of 10V=10V) represents maximum frequency of 60 Hz.



[Minimum Freq] = 0 Hz
 [Maximum Freq] = 60 Hz
 [Set 0-10 Vlt Lo] = 20%
 [Set 0-10 Vlt Hi] = 100%

2-10 volt input signal provides 0-60 Hz output, resulting in a 2 volt offset in the speed command.



[Minimum Freq] = 0 Hz
 [Maximum Freq] = 60 Hz
 [Set 0-10 Vlt Lo] = 100%
 [Set 0-10 Vlt Hi] = 0%

Maximum input (100% of 10V=10V) represents a minimum frequency of 0 Hz & minimum input (0% of 10V=0V) represents a maximum frequency of 60 Hz.

I/O Config

[Analog Out Sel]

This parameter selects the source that will drive the analog output. This output is intended for metering only and should not be used as process control feedback.

Important: Firmware versions below 4.01 will have fewer selections available.

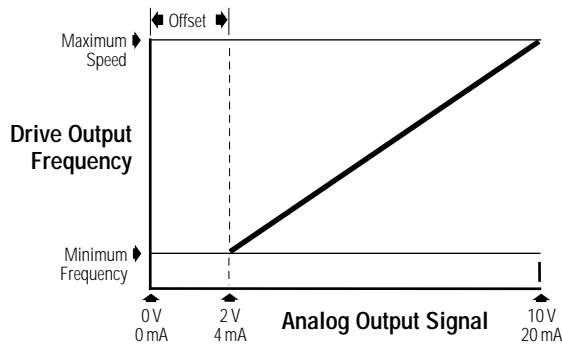
Parameter Number	25	
Parameter Type	Read and Write	
Factory Default	"Frequency"	
Units	Display	Drive
	"Frequency"	0 Zero to programmed [Maximum Freq]
	"Current"	1 Zero to 200%
	"Torque"	2 Zero to 200%
	"Power"	3 Zero to 200%
	"Voltage"	4 Zero to 200%
	"% Motor OL"	5 Zero to 200%
	"% Drive OL"	6 Zero to 200%
	"Encoder"	7 See [Pulse/Enc Hertz]
	"Speed Error"	8 See [Speed Error]
	"PI Reference"	9 See [PI Reference]
	"PI Feedback"	10 See [PI Feedback]
	"PI Error"	11 See [PI Error]
	"PI Output"	12 See [PI Output]

[Anlg Out Offset]

This parameter enables the voltage or current offset for the analog output TB2 terminals 4 & 9. This internal value offsets 0-20mA to 4-20mA and 0-10V to 2-10V.

Parameter Number	154	
Parameter Type	Read and Write	
Factory Default	"Disabled"	
Units	Display	Drive
	"Disabled"	0
	"Enabled"	1

Analog Out Offset



[Abs Analog Out] – Firmware 4.01 & later

This parameter selects whether a signed value or absolute value is used for analog out.

Parameter Number	233	
Parameter Type	Read and Write	
Factory Default	"Enabled"	
Units	Display	Drive
	"Disabled"	0
	"Enabled"	1

[Set Anlg Out Lo] – Firmware 4.01 & later

Sets the percentage of the [Analog Out Sel] value that equals 0V/0 mA output.

Parameter Number	234	
Parameter Type	Read and Write	
Display Units / Drive Units	0.1% / 4096 = 100%	
Factory Default	0.0%	
Minimum Value	-300.0%	
Maximum Value	+300.0%	

[Set Anlg Out Hi] – Firmware 4.01 & later

Sets the percentage of the [Analog Out Sel] value that equals 10V/20 mA output.

Parameter Number	235	
Parameter Type	Read and Write	
Display Units / Drive Units	0.1% / 4096 = 100%	
Factory Default	100.0%	
Minimum Value	-300.0%	
Maximum Value	+300.0%	

Faults

This group of parameters allows configuring, viewing and clearing drive faults.

[Fault Buffer 0-3]

These parameters store the last (4) faults that occur.

Parameter Number	86-89
Parameter Type	Read and Write
Factory Default	None
Units	Display Drive
	"0" 0 <i>Last Fault</i>
	"1" 1 <i>Fault from Buffer 0</i>
	"2" 2 <i>Fault from Buffer 1</i>
	"3" 3 <i>Fault from Buffer 2</i>

[Clear Fault]

Selecting "Clear Fault" and pressing Enter will clear any faults and return the drive to ready status.

Parameter Number	51
Parameter Type	Read and Write
Factory Default	"Ready"
Units	Display Drive
	"Ready" 0
	"Clear Fault" 1

[Cur Lim Trip En]

This setting determines the drive response when the hardware current limit is exceeded. The current limit is approximately 180% of [Rated VT Amps] for B Frame drives & up, and approximately 250% of [Rated VT Amps] for A Frame drives.

Parameter Number	82
Parameter Type	Read and Write
Factory Default	"Disabled"
Units	Display Drive
	"Disabled" 0 <i>No Fault Generated – C.L. Activated</i>
	"Enabled" 1 <i>Diag C Lim Flt Generated</i>

[Shear Pin Fault] – Firmware 4.01 & later

Enabling this parameter allows the drive to generate a Shear Pin Fault (F63) if the output amps exceed the programmed software current limit value in [Current Limit].

Parameter Number	226
Parameter Type	Read and Write
Factory Default	"Disabled"
Units	Display Drive
	"Disabled" 0 <i>No Fault Generated</i>
	"Enabled" 1 <i>Fault Generated</i>

[Motor OL Fault] – Firmware 4.01 & later

This parameter enables or disables the motor overload protection feature of the drive.

Parameter Number	201
Parameter Type	Read and Write
Factory Default	"Enabled"
Units	Display Drive
	"Disabled" 0 <i>No Fault Generated</i>
	"Enabled" 1 <i>Fault Generated</i>

[Line Loss Fault]

This setting determines how a 15% drop in DC Bus voltage will affect drive operation. See following diagram.

Parameter Number	40
Parameter Type	Read and Write
Factory Default	"Disabled" ("Enabled" frn < 4.01)
Units	Display Drive
	"Disabled" 0 <i>No Fault Generated</i>
	"Enabled" 1 <i>Power Loss Fault Generated</i>

Faults

Power Loss Ride-Thru

The 1336 plus has the ability to ride through short power interruptions. On loss of input power to the drive, the drive offers two methods of operation.

Diagram 1

With the Line Loss Fault parameter disabled, if a power interruption occurs (T1) the drive will continue to operate off stored DC bus energy until bus voltage drops to 85% of its nominal value (T2). At this point, the drive output is shut off, allowing the DC bus to discharge more slowly. The drive will retain its logic and operating status as long as bus voltage is above the absolute minimum bus voltage (refer to Appendix). If bus voltage should fall below this level (T5), the drive will trip and Undervolt Fault will be displayed. If input power is restored before this minimum is reached (T3) and bus voltage rises above the 85% level (T4), the drive will restore output power to the motor and resume running.

Diagram 2

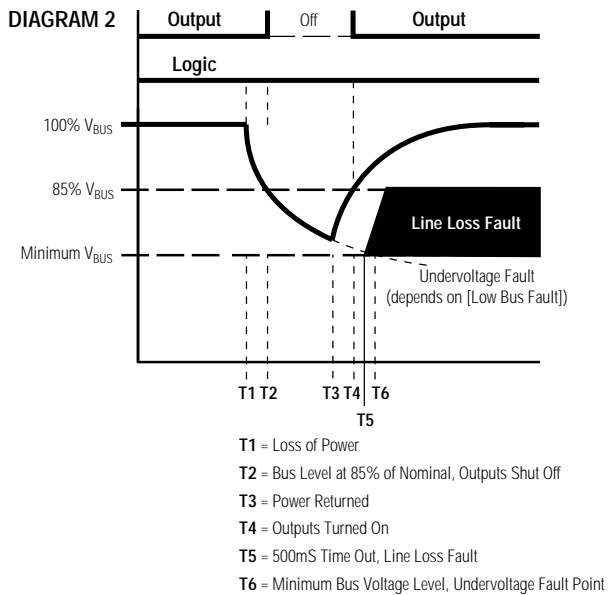
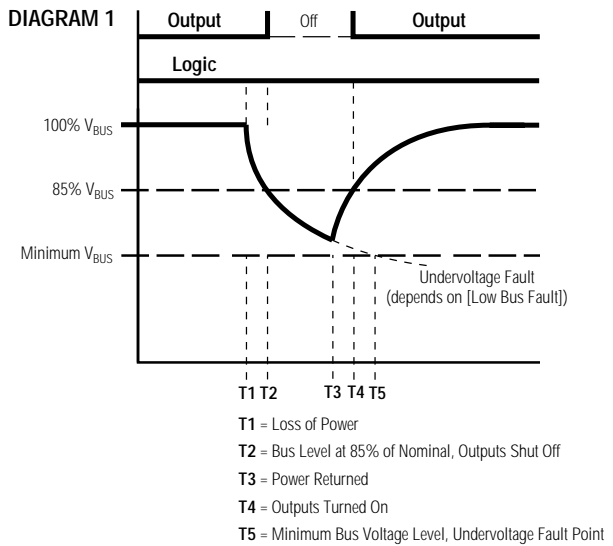
With the Line Loss Fault parameter enabled, if input power is lost (T1) the drive will continue to operate until the bus voltage falls below 85% of nominal (T2). At this point the drive output is turned off and a 500 ms timer is started. One of the following conditions will then occur:

1. The bus voltage will fall below minimum before the time expires (T6). This will generate an Undervolt Fault.
2. The bus voltage will remain below 85% but above minimum and the timer expires (T5). This will generate a Line Loss Fault.
3. The input power is restored (T3) and the bus voltage rises above the 85% level before the timer expires (T4). This allows the drive to turn its output on and resume running.

Line Loss Restart

In the event that a line loss condition occurs, the 1336 PLUS provides a variety of programmable selections to control the timing and method of reconnecting the motor after power returns. Choices include:

- Use flying start to determine motor speed.
- Check for motor terminal voltage to determine motor speed.
- Read the encoder, if present.
- Reconnect at last known output frequency.



Faults

[Blwn Fuse Flt]

Enabling this parameter will allow monitoring of the bus fuse (in 30 kW/40 HP and up drives) and cause a "Blwn Fuse Flt."

Parameter Number	81
Parameter Type	Read and Write
Factory Default	"Enabled"
Units	Display Drive
	"Disabled" 0 <i>No Fault Generated</i>
	"Enabled" 1 <i>Blwn Fuse Flt Generated</i>

[Low Bus Fault]

This parameter enables or disables the drive fault condition for bus voltage below the Bus Undervoltage Trip value listed in the Appendix.

Parameter Number	91
Parameter Type	Read and Write
Factory Default	"Enabled"
Units	Display Drive
	"Disabled" 0 <i>No Fault Generated</i>
	"Enabled" 1 <i>Undervolt Fault Generated</i>

[Fault Data] – Firmware 4.01 & later

This parameter displays fault related parameter numbers or bit array information. Certain faults generate additional information to aid fault diagnosis.

Parameter Number	207
Parameter Type	Read and Write
Display Units / Drive Units	Parameter # / Parameter #
Factory Default	None
Minimum Value	1
Maximum Value	255

[Flt Motor Mode]

This parameter displays the motor mode active at the time of the last fault.

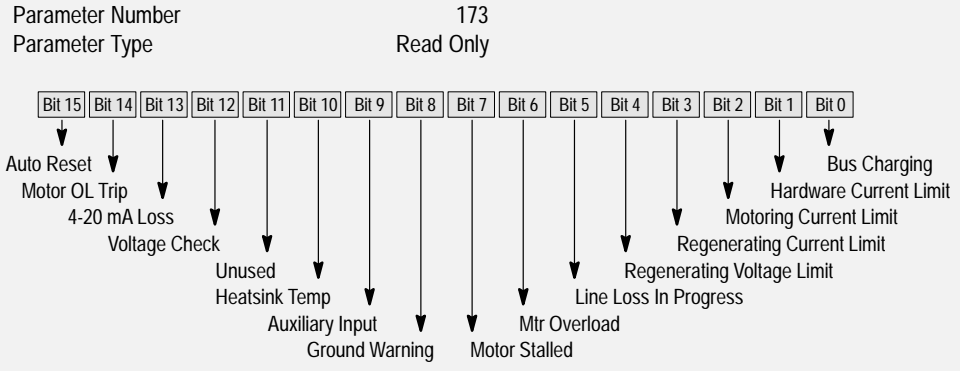
Parameter Number	143
Parameter Type	Read Only
Factory Default	None
Units	Display Drive
	"1" 1 <i>Power up sequence in progress</i>
	"2" 2 <i>Motor connected, drive off</i>
	"3" 3 <i>DC boost being applied</i>
	"4" 4 <i>Motor running at [Dwell Frequency]</i>
	"5" 5 <i>Motor accelerating</i>
	"6" 6 <i>Motor at command speed</i>
	"7" 7 <i>Motor decelerating</i>
	"8" 8 <i>Motor coasting</i>
	"9" 9 <i>Motor under DC braking</i>
	"10" 10 <i>Waiting for fault reset – returns to 0</i>
	"11" 11 <i>Start mode</i>
	"12" 12 <i>Flying start search enable</i>
	"13" 13 <i>Flying start w/encoder in process</i>

Faults

[Fault Alarms]

This parameter stores and displays the last alarm conditions present prior to a fault. Refer to Chapter 6 for further alarm information.

With drive software versions above 2.00 and a Series A (version 3.0) or Series B HIM, a Status description (bit ENUM) is displayed on line 1.



[Flt Clear Mode]

This parameter controls the method for clearing faults.

Parameter Number	39
Parameter Type	Read and Write
Factory Default	"Enabled"
Units	Display Drive
	"Disabled" 0
	"Enabled" 1

Faults cleared only by cycling power

Faults cleared by issuing a valid stop command (only through TB3/HIM) or cycling power – refer to Bit 3 of the Logic Control Structure on page A-13

[Ground Warning]

Enables the Ground Warning fault when the drive senses ground current in excess of 2 amperes (approximate). Refer to Chapter 6 for further information.

Parameter Number	204
Parameter Type	Read and Write
Factory Default	"Disabled"
Units	Display Drive
	"Disabled" 0
	"Enabled" 1

No Fault Generated

Ground Warning Generated

Diagnostics

This group of parameters contains values that can be helpful in explaining the operation of the drive. Drive status, direction, control and alarm conditions as well as drive ratings are included.

[Drive Status]

This parameter displays the actual operating condition in binary format.

Bits 0-7 are displayed on lower half of line 2 on HIM display, while, bits 8-15 are displayed on the upper half of line 2.

With drive software versions above 2.00 and a Series A (version 3.0) or Series B HIM, a Status description (bit ENUM) is displayed on line 1.

Parameter Number 59
Parameter Type Read Only

Reference	15	14	13	12	Local	11	10	9
Freq Select 1	0	0	0	0	TB3	0	0	0
Preset Freq 1	0	0	0	1	1	0	0	1
Preset Freq 2	0	0	1	0	2	0	1	0
Preset Freq 3	0	0	1	1	3	0	1	1
Preset Freq 4	0	1	0	0	4	1	0	0
Preset Freq 5	0	1	0	1	5	1	0	1
Preset Freq 6	0	1	1	0	6	1	1	0
Preset Freq 7	0	1	1	1	Unused	1	1	1
Freq Select 2	1	0	0	0				
Adapter 1	1	0	0	1				
Adapter 2	1	0	1	0				
Adapter 3	1	0	1	1				
Adapter 4	1	1	0	0				
Adapter 5	1	1	0	1				
Adapter 6	1	1	1	0				
Jog Frequency	1	1	1	1				

[2nd Drive Sts] – Frm. 4.01 & later

This parameter displays the actual operating condition in binary format.

Bits 0-7 are displayed on lower half of line 2 on HIM display, while, bits 8-15 are displayed on the upper half of line 2.

With drive software versions above 4.01 and a Series A (version 3.0) or Series B HIM, a Status description (bit ENUM) is displayed on line 1.

Parameter Number 236
Parameter Type Read Only

[Drive Alarm]

This parameter displays which alarm condition is present when bit 6 of [Drive Status] is high (set to 1). Refer to Chapter 6 for further alarm information.

With drive software versions above 2.00 and a Series A (version 3.0) or Series B HIM, a Status description (bit ENUM) is displayed on line 1.

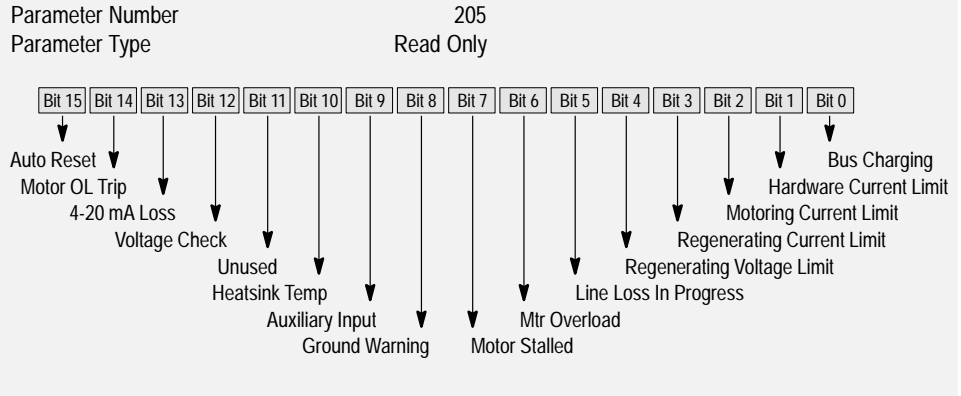
Parameter Number 60
Parameter Type Read Only

Diagnostics

[Latched Alarms]

This parameter “stores” the [Drive Alarm] indications (see above). Bits will remain set (high/1), even if the alarm condition no longer exists. The bit(s) must be programmed to zero to release the stored indications.

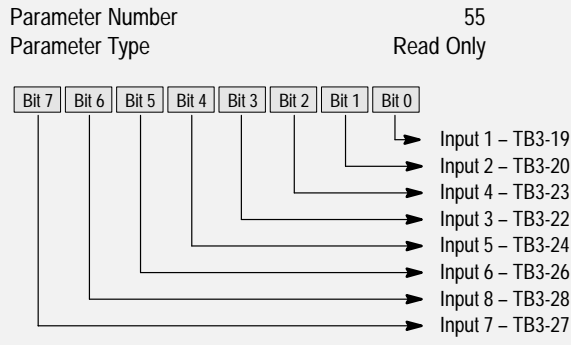
With drive software versions above 2.00 and a Series A (version 3.0) or Series B HIM, a Status description (bit ENUM) is displayed on line 1.



[Input Status]

This parameter displays the on/off status of inputs 1-8 at TB3 if an optional interface card is installed.

With drive software versions above 2.00 and a Series A (version 3.0) or Series B HIM, a Status description (bit ENUM) is displayed on line 1.



[Freq Source]

This parameter displays the frequency source currently commanding the drive.

Parameter Number	62
Parameter Type	Read Only
Factory Default	None
Units	Display Drive
	"Adapter 1-6" 6-11
	"Preset 1-7" 12-18
	"Use Last" 0
	"Remote Pot" 1
	"0-10 Volt" 2
	"4-20 mA" 3
	"Pulse Ref" 4
	"MOP" 5

[Freq Command]

This parameter displays the frequency that the drive is commanded to output. This command may come from any one of the frequency sources selected by [Freq Select 1] or [Freq Select 2].

Parameter Number	65
Parameter Type	Read Only
Display Units / Drive Units	0.01 Hertz / 32767 = Maximum Freq Forward
Factory Default	None
Minimum Value	-400.00 Hz
Maximum Value	+ 400.00 Hz

[Drive Direction]

This parameter displays the commanded running direction.

Parameter Number	69
Parameter Type	Read Only
Factory Default	None
Units	Display Drive
	"Forward" 0
	"Reverse" 1

Diagnostics

[Stop Mode Used] This parameter displays the active stop mode.	Parameter Number	26	
	Parameter Type	Read Only	
	Factory Default	None	
	Units	Display	Drive
		"Coast"	0
		"DC Brake"	1
	"Ramp"	2	
	"S-Curve"	3	
	"Ramp to Hold"	4	

[Motor Mode] This parameter displays the motor mode.	Parameter Number	141	
	Parameter Type	Read Only	
	Factory Default	None	
	Units	Display	Drive
		"1"	1 <i>Power up sequence in progress</i>
		"2"	2 <i>Motor connected, drive off</i>
		"3"	3 <i>DC boost being applied</i>
		"4"	4 <i>Motor running at [Dwell Frequency]</i>
		"5"	5 <i>Motor accelerating</i>
		"6"	6 <i>Motor at command speed</i>
		"7"	7 <i>Motor decelerating</i>
		"8"	8 <i>Motor coasting</i>
		"9"	9 <i>Motor under DC braking</i>
		"10"	10 <i>Waiting for fault reset – returns to 0</i>
	"11"	11 <i>Start mode</i>	
	"12"	12 <i>Flying start search enable</i>	
	"13"	13 <i>Flying start w/encoder in process</i>	

[Power Mode] This parameter displays the power mode.	Parameter Number	142	
	Parameter Type	Read Only	
	Factory Default	None	
	Units	Display	Drive
		"1"	1 <i>Power up sequence in progress</i>
		"2"	2 <i>Precharge in progress</i>
		"3"	3 <i>Bus voltage being stored in memory</i>
		"4"	4 <i>Ready for run command after power up</i>
		"5"	5 <i>Power stage diagnostics running</i>
		"6"	6 <i>Line loss detection occurred</i>
		"7"	7 <i>Ready for run command after stop</i>
		"8"	8 <i>Drive running</i>
		"9"	9 <i>Motor flux decay delay</i>
		"10"	10 <i>DC braking in progress</i>
		"11"	11 <i>Drive fault occurred</i>
		"12"	12 <i>Flying start search enabled</i>
	"13"	13 <i>Deceleration in progress</i>	
	"14"	14 <i>SCR wake mode</i>	
	"15"	15 <i>SCR check mode</i>	
	"16"	16 <i>SCR wait mode</i>	

Diagnosics

[Output Pulses]

This parameter displays the number of output cycles for the PWM waveform. The count rolls over at 65535.

Parameter Number	67
Parameter Type	Read Only
Display Units / Drive Units	1 Pulse / Pulses
Factory Default	None
Minimum Value	0
Maximum Value	65535

[Current Angle]

Firmware Version 3.04 and below
This parameter displays the angle, in degrees, of displacement between output voltage and output current. The cosine of this number is an approximation of output power factor.

Firmware Version 4.01 and higher
This parameter has no function.

Parameter Number	72
Parameter Type	Read Only
Display Units / Drive Units	1 Deg / 255 = 360 Deg
Factory Default	None

[Heatsink Temp]

This parameter displays the heatsink temperature.

Parameter Number	70
Parameter Type	Read Only
Display Units / Drive Units	1° C / Deg. C
Factory Default	None
Minimum Value	0
Maximum Value	255° C

[Set Defaults]

Setting this parameter to "Defaults Init" resets all parameters to their factory values.

Parameter Number	64
Parameter Type	Read and Write
Factory Default	"Ready"
Units	Display Drive
	"Ready" 0 <i>Display after function complete.</i>
	"Store to EE" 1
	"Rcll frm EE" 2
	"Default Init" 3 <i>Resets all parameters to factory settings.</i>

[DC Bus Memory]

This parameter displays the nominal DC bus voltage level. This value is used to determine line loss, overvoltage, decel frequency and other points.

Parameter Number	212
Parameter Type	Read Only
Display Units / Drive Units	1 Volt / Volts
Display	Volts

[EEPROM Cksum] – Firmware 4.01 & later

The value of this parameter provides a checksum value that indicates a change in drive programming has occurred.

Parameter Number	172
Parameter Type	Read Only
Display Units / Drive Units	None

Ratings

This group contains a number of "Read Only" parameters that display drive operating characteristics. This group will only be available with firmware versions 2.01 and above. Refer to the "Diagnostics" group if your firmware is below 2.01.

[Drive Type]	Parameter Number	61
	Parameter Type	Read Only
This parameter displays a decimal number which can be translated into the drive catalog number by using the adjacent chart. Refer to Chapter 1 for an explanation of the catalog numbers.	Display 1336S- ...	Display 1336S- ...
	8449 AQF05	8707 BRF10
	8450 AQF07	8708 BRF15
	8451 AQF10	8709 BRF20
	8452 AQF15	8710 BRF30
	8453 AQF20	8711 BRF50
	8454 AQF30	8712 BRF75
	8455 AQF50	8713 BRF100
	12552 A007	12808 B007
	12553 A010	12809 B010
	12554 A015	12810 B015
	12555 A020	12811 B020
	12556 A025	12812 B025
	12557 A030	12813 B030
	12558 A040	12824 BX040
	12559 A050	12814 B040
	12560 A060	12815 B050
	12561 A075	12816 BX060
	12562 A100	12825 B060
	12563 A125	12817 B075
	8705 BRF05	12818 B100
	8706 BRF07	12819 B125
		12826 BX150
		12820 B150
		12821 B200
		12827 B250
		12838 BP250
		12828 BX250
	12829 B300	
	12839 BP300	
	12822 B350	
	12840 BP350	
	12830 B400	
	12841 BP400	
	12832 B450	
	12842 BP450	
	12823 B500	
	12833 B600	
	8963 CWF10	
	8965 CWF20	
	8966 CWF30	
	8967 CWF50	
	13064 C007	
	13065 C010	
	13066 C015	
	13067 C020	
	13068 C025	
	13069 C030	
	13070 C040	
	13071 C050	
	13072 C060	
	13073 C075	
	13074 C100	
	13075 C125	
	13076 C150	
	13077 C200	
	13083 C250	
	13091 CX300	
	13085 C300	
	13078 C350	
	13086 C400	
	13088 C450	
	13079 C500	
	13089 C600	

[Firmware Ver.]	Parameter Number	71
	Parameter Type	Read Only
This parameter displays the version number of the drive firmware.	Display Units / Drive Units	None / Version x 100
	Display	0.00

[Drive Rtd Volts]	Parameter Number	147
	Parameter Type	Read Only
This parameter displays the rated input voltage of the drive.	Display Units / Drive Units	1 Volt / Volts
	Display	Drive Rated Input Voltage

[Rated Amps]	Parameter Number	170
	Parameter Type	Read Only
This parameter displays the rated output current of the drive.	Display Units / Drive Units	0.1 Amp / Amps x 10
	Display	Drive Rated Output Amps

[Rated kW]	Parameter Number	171
	Parameter Type	Read Only
This parameter displays the rated kW of the drive.	Display Units / Drive Units	kW / kW x 100
	Display	Drive Rated Output kW

[Rated CT Amps]	Parameter Number	148
	Parameter Type	Read Only
This parameter displays the rated output current of the drive.	Display Units / Drive Units	0.1 Amp / Amps x 10
	Display	Drive Rated Output Amps

Ratings

[Rated CT kW]

This parameter displays the rated CT kW of the drive.

Parameter Number	149
Parameter Type	Read Only
Display Units / Drive Units	kW / kW x 100
Display	Drive Rated Output kW

[Rated VT Amps]

This parameter displays the rated output current of the drive.

Parameter Number	198
Parameter Type	Read Only
Display Units / Drive Units	0.1 Amp / Amps x 10
Display	Drive Rated Amps

[Rated VT kW]

This parameter displays the rated VT kW of the drive.

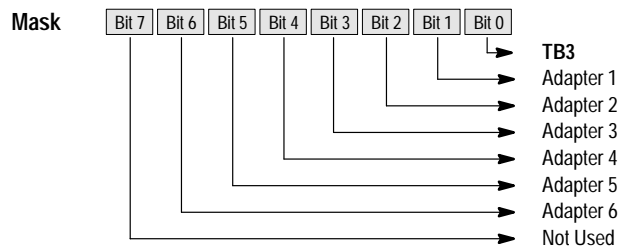
Parameter Number	199
Parameter Type	Read Only
Display Units / Drive Units	kW / kW x 100
Display	Drive Rated kW

Masks

This group of parameters contains binary masks for all control functions. The masks control which adapters can issue control commands.

Each mask contains a bit for each adapter. Individual bits can be set to "Zero" to lockout control by an adapter or set to "1" to permit an adapter to have control.

With drive software versions above 2.00 and a Series A (version 3.0) or Series B HIM, a Status description (bit ENUM) is displayed on line 1.



[Direction Mask]

This parameter controls which adapters can issue forward/reverse commands.

Parameter Number	94
Parameter Type	Read and Write
Factory Default	01111110
Units	Display Drive
	"0" 0 Deny Control
	"1" 1 Permit Control

[Start Mask]

This parameter controls which adapters can issue start commands.

Parameter Number	95
Parameter Type	Read and Write
Factory Default	01111111
Units	Display Drive
	"0" 0 Deny Control
	"1" 1 Permit Control

[Jog Mask]

This parameter controls which adapters can issue jog commands.

Parameter Number	96
Parameter Type	Read and Write
Factory Default	01111111
Units	Display Drive
	"0" 0 Deny Control
	"1" 1 Permit Control

Masks

[Reference Mask]

This parameter controls which adapters can select an alternate reference; [Frequency Sel 1], [Frequency Sel 2] or preset speeds.

Parameter Number	97
Parameter Type	Read and Write
Factory Default	01111111
Units	Display Drive
	"0" 0 <i>Deny Control</i>
	"1" 1 <i>Permit Control</i>

[Accel Mask]

This parameter controls which adapters can select [Accel Time 1] and [Accel Time 2].

Parameter Number	98
Parameter Type	Read and Write
Factory Default	01111111
Units	Display Drive
	"0" 0 <i>Deny Control</i>
	"1" 1 <i>Permit Control</i>

[Decel Mask]

This parameter controls which adapters can select [Decel Time 1] and [Decel Time 2].

Parameter Number	99
Parameter Type	Read and Write
Factory Default	01111111
Units	Display Drive
	"0" 0 <i>Deny Control</i>
	"1" 1 <i>Permit Control</i>

[Fault Mask]

This parameter controls which adapters can reset a fault.

Parameter Number	100
Parameter Type	Read and Write
Factory Default	01111111
Units	Display Drive
	"0" 0 <i>Deny Control</i>
	"1" 1 <i>Permit Control</i>

[MOP Mask]

This parameter controls which adapters can issue MOP commands to the drive.

Parameter Number	101
Parameter Type	Read and Write
Factory Default	01111111
Units	Display Drive
	"0" 0 <i>Deny Control</i>
	"1" 1 <i>Permit Control</i>

[Logic Mask]

Determines which adapters can control the drive. If the bit for an adapter is set to "0," the adapter will have no control functions except for stop. In addition, the adapter can be removed from the drive while power is applied without causing a serial fault.

Parameter Number	92
Parameter Type	Read and Write
Factory Default	01111111
Units	Display Drive
	"0" 0 <i>Deny Control</i>
	"1" 1 <i>Permit Control</i>

[Local Mask]

This parameter controls which adapters are allowed to take exclusive control of drive logic commands (except stop). Exclusive "local" control can only be taken while the drive is stopped.

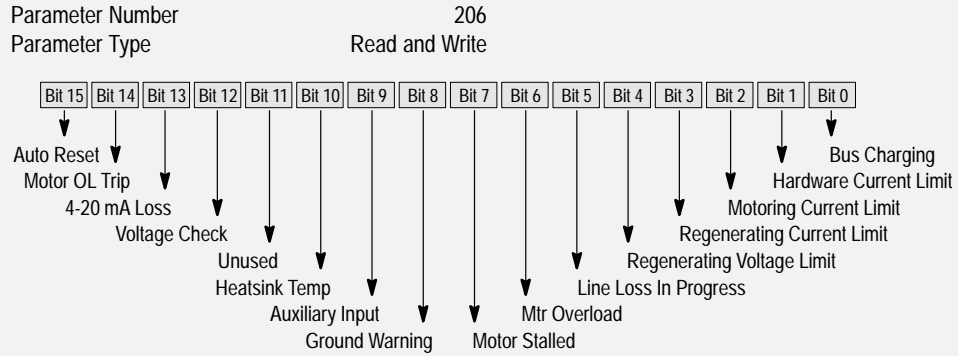
Parameter Number	93
Parameter Type	Read and Write
Factory Default	01111111
Units	Display Drive
	"0" 0 <i>Deny Control</i>
	"1" 1 <i>Permit Control</i>

Masks

[Alarm Mask]

Controls which alarm conditions will activate the alarm contact (refer to Chapter 2 – TB2) and set the alarm bit (bit 6) in [Drive Status].

With drive software versions above 2.00 and a Series A (version 3.0) or Series B HIM, a Status description (bit ENUM) is displayed on line 1.



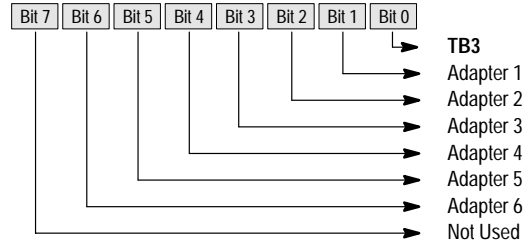
Owners

This group of parameters contains binary information to display which group of adapters are issuing control commands.

Each Owner Parameter contains a bit for each adapter. The drive will set an adapter's bit to "1" when that adapter is issuing a logic command and to "Zero" when no command is being issued.

With drive software versions above 2.00 and a Series A (version 3.0) or Series B HIM, a Status description (bit ENUM) is displayed on line 1.

Owners Display



[Stop Owner]

This parameter displays which adapters are presently issuing a valid stop command.

Parameter Number	102	
Parameter Type	Read Only	
Units	Display	Drive
	"0"	0 Stop Input Not Present
	"1"	1 Stop Input Present

[Direction Owner]

This parameter displays which adapter currently has exclusive control of direction changes.

Parameter Number	103	
Parameter Type	Read Only	
Units	Display	Drive
	"0"	0 Non-Owner
	"1"	1 Current Owner

[Start Owner]

This parameter displays which adapters are presently issuing a valid start command.

Parameter Number	104	
Parameter Type	Read Only	
Units	Display	Drive
	"0"	0 Start Input Not Present
	"1"	1 Start Input Present

Owners

[Jog Owner] This parameter displays which adapters are presently issuing a valid jog command.	Parameter Number	105
	Parameter Type	Read Only
	Units	Display Drive
		"0" 0 <i>Jog Input Not Present</i> "1" 1 <i>Jog Input Present</i>

[Reference Owner] This parameter displays which adapter currently has the exclusive control of the selection of the command frequency source.	Parameter Number	106
	Parameter Type	Read Only
	Units	Display Drive
		"0" 0 <i>Non-Owner</i> "1" 1 <i>Current Owner</i>

[Accel Owner] This parameter displays which adapter has exclusive control of selecting [Accel Time 1] or [Accel Time 2].	Parameter Number	107
	Parameter Type	Read Only
	Units	Display Drive
		"0" 0 <i>Non-Owner</i> "1" 1 <i>Current Owner</i>

[Decel Owner] This parameter displays which adapter has exclusive control of selecting [Decel Time 1] or [Decel Time 2].	Parameter Number	108
	Parameter Type	Read Only
	Units	Display Drive
		"0" 0 <i>Non-Owner</i> "1" 1 <i>Current Owner</i>

[Fault Owner] This parameter displays which adapter is presently resetting a fault.	Parameter Number	109
	Parameter Type	Read Only
	Units	Display Drive
		"0" 0 <i>Non-Owner</i> "1" 1 <i>Current Owner</i>

[MOP Owner] This parameter displays which adapters are currently issuing increases or decreases in MOP Command Frequency.	Parameter Number	110
	Parameter Type	Read Only
	Units	Display Drive
		"0" 0 <i>Non-Owner</i> "1" 1 <i>Current Owner</i>

[Local Owner] This parameter displays which adapter has requested exclusive control of all drive logic functions. If an adapter is in local lockout, all other functions (except stop) on all other adapters are locked out and non-functional. Local control can only be obtained when the drive is not running.	Parameter Number	179
	Parameter Type	Read Only
	Units	Display Drive
		"0" 0 <i>Non-Owner</i> "1" 1 <i>Current Owner</i>

Adapter I/O

This group of parameters contains the parameters needed for an optional communications adapter to communicate with the drive.

These parameters determine the parameter number to which PLC output data table or SCANport device image information will be written. Refer to the A-B Single Point Remote I/O Adapter manuals or other SCANport device manual for data link information.

	Parameter Number	111-118
	Parameter Type	Read and Write
	Display Units / Drive Units	Parameter # / Parameter #
	1336 PLUS	SCANport Device
[Data In A1]		}
[Data In A2]		
[Data In B1]		
[Data In B2]		
[Data In C1]		
[Data In C2]		
[Data In D1]		
[Data In D2]		

These parameters determine the parameter number whose value will be read into the PLC input data table or SCANport device image. Refer to the A-B Single Point Remote I/O Adapter manuals or other SCANport device manual for data link information.

	Parameter Number	119-126
	Parameter Type	Read and Write
	Display Units / Drive Units	Parameter # / Parameter #
	1336 PLUS	SCANport Device
[Data Out A1]		}
[Data Out A2]		
[Data Out B1]		
[Data Out B2]		
[Data Out C1]		
[Data Out C2]		
[Data Out D1]		
[Data Out D2]		

Process Display

This group of parameters contains the parameters used to scale, in "User Units", any drive parameter for display on the HIM. Two scaled parameter values can be simultaneously displayed when Process Mode is selected.

[Process 1 Par]

This parameter should be set to the number of the parameter whose scaled value will be displayed on Line 1 of the HIM Display Panel.

The maximum process value that can be displayed is 99,999.99. If this value is exceeded, a character string of asterisks (****) will appear on the display.

Parameter Number	127
Parameter Type	Read and Write
Display Units / Drive Units	Parameter # / Parameter #
Factory Default	1

[Process 1 Scale]

This value sets the scaling multiplier for [Process 1 Par]. The displayed value will be:

$$\begin{array}{r} \text{[Process 1 Par] actual value} \\ \times \text{ [Process 1 Scale] value} \\ \hline \text{Displayed Value} \end{array}$$

Parameter Number	128
Parameter Type	Read and Write
Display Units / Drive Units	Numeric / Scale x 100
Factory Default	+1.00
Minimum Value	-327.68
Maximum Value	+ 327.67

[Process 1 Txt 1-8]

Sets the "User Units" description for the value determined by [Process 1 Par] and [Process 1 Scale]. This 8 character description will be shown on line 1 of the display. Refer to the Character Map in Appendix A.

Parameter Number(s)	129-136
Parameter Type	Read and Write
Display Units / Drive Units	ASCII Code / ASCII Code
Factory Default	"Volts "

[Process 2 Par]

This parameter should be set to the number of the parameter whose scaled value will be displayed on Line 2 of the HIM Display Panel.

The maximum process value that can be displayed is 99,999.99. If this value is exceeded, a character string of asterisks (****) will appear on the display.

Parameter Number	180
Parameter Type	Read and Write
Display Units / Drive Units	Parameter # / Parameter #
Factory Default	54

[Process 2 Scale]

This value sets the scaling multiplier for [Process 2 Par]. The displayed value will be:

$$\begin{array}{r} \text{[Process 2 Par] actual value} \\ \times \text{ [Process 2 Scale] value} \\ \hline \text{Displayed Value} \end{array}$$

Parameter Number	181
Parameter Type	Read and Write
Display Units / Drive Units	Numeric / Scale x 100
Factory Default	+1.00
Minimum Value	-327.68
Maximum Value	+ 327.67

[Process 2 Txt 1-8]

Sets the "User Units" description for the value determined by [Process 2 Par] and [Process 2 Scale]. This 8 character description will be shown on line 2 of the display. Refer to the Character Map in Appendix A.

Parameter Number(s)	182-189
Parameter Type	Read and Write
Display Units / Drive Units	ASCII Code / ASCII Code
Factory Default	"Amps "

Encoder Feedback

This group of parameters contains all the parameters necessary to activate encoder feedback for closed loop operation.

[Speed Control]

This parameter selects the type of speed modulation active in the drive.

This parameter cannot be changed while the drive is running.

Important: If encoder feedback closed loop speed regulation is required, "Encoder Fdbk" must be selected.

Parameter Number	77
Parameter Type	Read and Write
Factory Default	"Slip Comp" ("No Control" frn < 4.01)
Units	Display Drive
	"No Control" 0 <i>Frequency regulation</i>
	"Slip Comp" 1 <i>Slip compensation</i>
	"Speed Droop" 2 <i>Negative slip compensation</i>
	"PLL" 3 <i>Phase lock loop (requires frn < 4.01)</i>
	"Encoder Fdbk" 4 <i>Encoder feedback-closed loop</i>
	"Droop + Reg" 5 <i>Enc. fdbk.-closed loop w/ active droop</i>
	"P Jump" 6 <i>Traverse function</i>
	"Process PI" 7 <i>Closed loop PI control</i>

[Encoder Type]

This parameter contains the feedback encoder signal type. The drive can accept single-ended, single-channel (Pulse) or differential (Quadrature) signals.

This cannot be changed while drive is running.

Parameter Number	152
Parameter Type	Read and Write
Factory Default	"Pulse"
Units	Display Drive
	"Pulse" 0
	"Quadrature" 1

[Pulse/Enc Scale]

This parameter contains the scaling factor for both pulse train inputs (TB2-7, 8) and encoder feedback speed regulation (TB3 terminals 31-36).

1. Encoder Feedback Operation
Enter actual encoder pulses per revolution

2. Pulse Train Input

$$\text{Scale Factor} = \frac{\text{Incoming Pulse Rate (Hz)}}{\text{Desired Command Freq.}} \times \frac{\text{Motor Poles}}{2}$$

Parameter Number	46
Parameter Type	Read and Write
Display Units / Drive Units	Factor / Pulses per Rev
Factory Default	1024 PPR (64 PPR frn < 4.01)
Minimum Value	1
Maximum Value	4096
Pulse Train Example:	
4 Pole Motor, 60 Hz = Max. Speed.	$\text{Pulse/Enc Scale} = \frac{3840 \text{ Hz}}{60 \text{ Hz}} \times \frac{4 \text{ Poles}}{2} = 128$
The 1336-MOD-N1 option outputs 64 Hz/Hz.	
At full analog reference, the pulse output will be 60 Hz x 64 Hz/Hz = 3840 pulses/sec.	This value will create a command frequency of 60 Hz for full analog reference to the option.

[Maximum Speed]

This Parameter sets the output frequency at full frequency reference for:

- Encoder feedback speed regulation.
- All analog inputs to TB2 (remote pot, 0-10V & 0-20 mA).

NOTE: [Maximum Freq.] must be raised to allow operation or modulation above [Maximum Speed].

Parameter Number	151
Parameter Type	Read and Write
Display Units / Drive Units	1 Hertz / Hertz x 10 (x 1 frn < 4.01)
Factory Default	400 Hz
Minimum Value	0 Hz
Maximum Value	400 Hz

[Motor Poles]

This parameter contains the number of motor magnetic poles. This value translates output frequency into actual motor RPM during closed loop operation. It is calculated from [Motor NP Hertz] and [Motor NP RPM].

Parameter Number	153
Parameter Type	Read Only
Display Units / Drive Units	1 Poles / Poles

Encoder Feedback

[Speed KI] This parameter contains the integral gain value for the velocity loop during closed loop operation.	Parameter Number	165
	Parameter Type	Read and Write
	Display Units / Drive Units	Numeric / Gain x 100
	Factory Default	100
	Minimum Value	0
	Maximum Value	20000
[Speed Error] This parameter displays the difference between [Freq Command] and feedback speed.	Parameter Number	166
	Parameter Type	Read Only
	Display Units / Drive Units	0.01 Hertz / 32767 = Maximum Freq.
	Factory Default	None
	Minimum Value	- 8.33% of [Base Frequency]
	Maximum Value	+ 8.33% of [Base Frequency]
[Speed Integral] This parameter displays the integral value from the speed loop.	Parameter Number	167
	Parameter Type	Read Only
	Display Units / Drive Units	0.01 Hertz / 32767 = Maximum Freq.
	Factory Default	None
	Minimum Value	-8.33% of [Base Frequency]
	Maximum Value	+ 8.33% of [Base Frequency]
[Speed Adder] This parameter displays the amount of correction applied to the [Freq Command].	Parameter Number	168
	Parameter Type	Read Only
	Display Units / Drive Units	0.01 Hertz / 32767 = Maximum Freq.
	Factory Default	None
	Minimum Value	- 8.33% of [Base Frequency]
	Maximum Value	+ 8.33% of [Base Frequency]
[Motor NP RPM] This value should be set to the motor nameplate rated RPM. This parameter cannot be changed while the drive is running.	Parameter Number	177
	Parameter Type	Read and Write
	Display Units / Drive Units	1 RPM / RPM x 10 (x 1 frn < 4.01)
	Factory Default	1750 RPM
	Minimum Value	60 RPM
	Maximum Value	24000 RPM
[Motor NP Hertz] This value should be set to the motor nameplate rated frequency. This parameter cannot be changed while the drive is running.	Parameter Number	178
	Parameter Type	Read and Write
	Display Units / Drive Units	1 Hertz / Hertz x 10 (x 1 frn < 4.01)
	Factory Default	60 Hz
	Minimum Value	1 Hz
	Maximum Value	400 Hz
[Pulse/Enc Hertz] This parameter displays the frequency command present at pulse input terminals 7 & 8 of TB2 or at the encoder input terminals on TB3 (if present). This value is displayed whether or not this is the active frequency command.	Parameter Number	63
	Parameter Type	Read Only
	Display Units / Drive Units	0.01 Hertz / 32767 = Maximum Freq
	Factory Default	None
	Minimum Value	0.00 Hz
	Maximum Value	400.00 Hz

Process PI

This group of parameters configures the Process PI Regulator.

[Speed Control]

This parameter selects the type of speed modulation active in the drive.

This parameter cannot be changed while the drive is running.

Important: If encoder feedback closed loop speed regulation is required, "Encoder Fdbk" must be selected.

Parameter Number	77
Parameter Type	Read and Write
Factory Default	"Slip Comp" ("No Control" frn < 4.01)
Units	Display Drive
	"No Control" 0 Frequency regulation
	"Slip Comp" 1 Slip compensation
	"Speed Droop" 2 Negative slip compensation
	"PLL" 3 Phase lock loop (requires frn < 4.01)
	"Encoder Fdbk" 4 Encoder feedback-closed loop
	"Droop + Reg" 5 Enc. fdbk-closed loop w/ active droop
	"P Jump" 6 Traverse function
	"Process PI" 7 Closed loop PI control

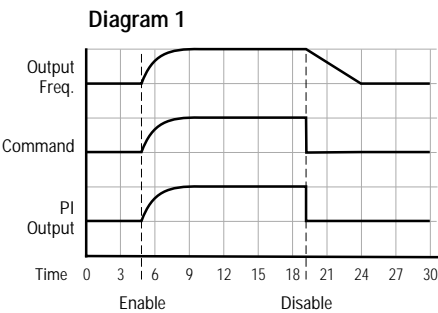
[PI Config]

This parameter sets and displays the configuration for the PI regulator.

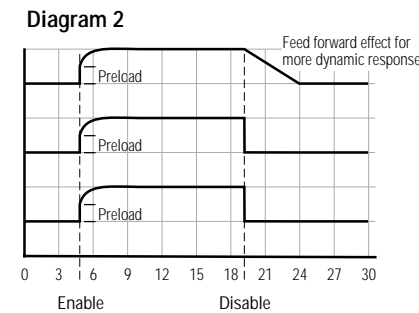
Note: Reset Integrator (Int) is also available through a digital input. See *Input Mode Selection in Chapter 2*.

Parameter Number	213
Parameter Type	Read/Write
Factory Default	00000000

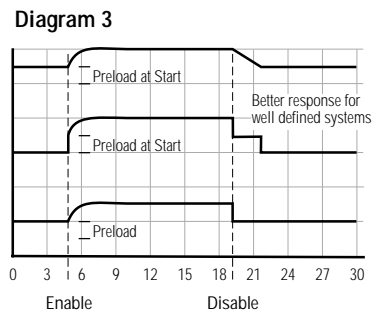
Bit 7	Bit 6	Bit 5	Bit 4	Bit 3	Bit 2	Bit 1	Bit 0
↓ Spare							
							Inv Error – Changes sign of PI Error
							Reset Int – Holds KI at zero
							Zero Clamp – Prevents bidirectional operation
							Sqrt Fdbk – Uses square root of PI feedback value
							Set Output
							Preload Int
							PI Enable
							Diagram
							1 2 3



Enable PI output integrates from zero – drive ramps to regulated frequency.
Disable PI output is forced to zero – drive ramps to unregulated frequency.



Enable PI output steps to preload and integrates from there – drive steps to preload and ramps from there.
Disable PI output is forced to zero - drive ramps to unregulated frequency.



Enable PI output integrates from preload – drive ramps from preload.
Disable PI output is held at preload - drive ramps to unregulated speed (min. preload).
 Note: Drive will step output equal to preload on start.

[PI Status]

This parameter displays the status of the Process PI regulator.

Parameter Number	214
Parameter Type	Read Only
Factory Default	None

Bit 7	Bit 6	Bit 5	Bit 4	Bit 3	Bit 2	Bit 1	Bit 0
							Enabled
							Spare

Process PI

[PI Ref Select]

The source of the PI reference is selected with this parameter. The value from the selected reference is the "set point" for the Process PI regulator.

If using firmware version 4.01 and up, the drive is capable of responding to a loss of the 4-20 mA signal used as either a PI reference or PI feedback. Response to loss of 4-20 mA signal is controlled by programming and requires the following:

- a) [Speed Control] must be set to "Process PI" and
- b) Either [PI Ref Select] or [PI Fdbk Select] must be set to "4-20 mA."

If both of the above conditions are met, the signal loss response is controlled by the setting of [4-20 mA Loss Sel]. If this parameter is set to "Stop/Fault," loss of input will cause the drive to stop and issue a Hertz Err Fault. Loss of input while any other setting of [4-20 mA Loss Sel] is chosen will cause the drive to activate the alarm bit (bit 6 of [Drive Status] and bit 13 of [Drive Alarm]) and output programmed [Minimum Freq].

No signal loss protection is offered for the 0-10V input.

Parameter Number	215
Parameter Type	Read/Write
Factory Default	"Preset 1"
Units	Display Drive
	"Adapter 1" 6
	"Adapter 2" 7
	"Adapter 3" 8
	"Adapter 4" 9
	"Adapter 5" 10
	"Adapter 6" 11
	"Preset 1-7" 12-18
	"Remote Pot" 1
	"0-10 Volt" 2
	"4-20 mA" 3
	"Pulse Ref" 4
	"MOP" 5

[PI Fdbk Select]

The source of the PI feedback is selected with this parameter. It identifies the input point for the process feedback device.

Parameter Number	216
Parameter Type	Read/Write
Factory Default	"0-10 Volt"
Units	Display Drive
	"Adapter 1" 6
	"Adapter 2" 7
	"Adapter 3" 8
	"Adapter 4" 9
	"Adapter 5" 10
	"Adapter 6" 11
	"Preset 1-7" 12-18
	"Remote Pot" 1
	"0-10 Volt" 2
	"4-20 mA" 3
	"Pulse Ref" 4
	"MOP" 5

[PI Reference]

This parameter displays the current value of the reference selected by [PI Ref Select].

Parameter Number	217
Parameter Type	Read Only
Display Units / Drive Units	0.01 Hertz / 32767 = Maximum Freq Forward
Factory Default	None
Minimum Value	-400.00 Hz
Maximum Value	400.00 Hz

Process PI

[PI Feedback]

This parameter displays the current value of the reference selected by [PI Fdbk Select].

Parameter Number	218
Parameter Type	Read Only
Display Units / Drive Units	0.01 Hertz / 32767 = Maximum Freq Forward
Factory Default	None
Minimum Value	-400.00 Hz
Maximum Value	400.00 Hz

[PI Error]

The value of the error calculated by the PI loop. This value is the difference between [PI Reference] & [PI Feedback] and determines the PI output.

Parameter Number	219
Parameter Type	Read Only
Display Units / Drive Units	0.01 Hertz / 32767 = Maximum Freq Forward
Factory Default	None
Minimum Value	-400.00 Hz
Maximum Value	400.00 Hz

[PI Output]

The current output of the PI loop is displayed with this parameter. This output is used as the speed command for process control or the speed adder for process trim.

Parameter Number	220
Parameter Type	Read Only
Display Units / Drive Units	0.01 Hertz / 32767 = Maximum Freq Forward
Factory Default	None
Minimum Value	-400.00 Hz
Maximum Value	400.00 Hz

[KI Process]

This parameter sets the integral gain of the process PI loop.

Parameter Number	221
Parameter Type	Read/Write
Display Units / Drive Units	NA / NA
Factory Default	128
Minimum Value	0
Maximum Value	1024

[KP Process]

This parameter sets the proportional gain of the process PI loop.

Parameter Number	222
Parameter Type	Read/Write
Display Units / Drive Units	NA / NA
Factory Default	256
Minimum Value	0
Maximum Value	1024

[PI Neg Limit]

This parameter sets the lower (negative) limit of the PI output.

Parameter Number	223
Parameter Type	Read/Write
Display Units / Drive Units	0.01 Hertz / 32767 = Maximum Freq Forward
Factory Default	-8.33% of [Maximum Freq]
Minimum Value	-400.00 Hz
Maximum Value	400.00 Hz

[PI Pos Limit]

This parameter sets the upper (positive) limit of the PI output.

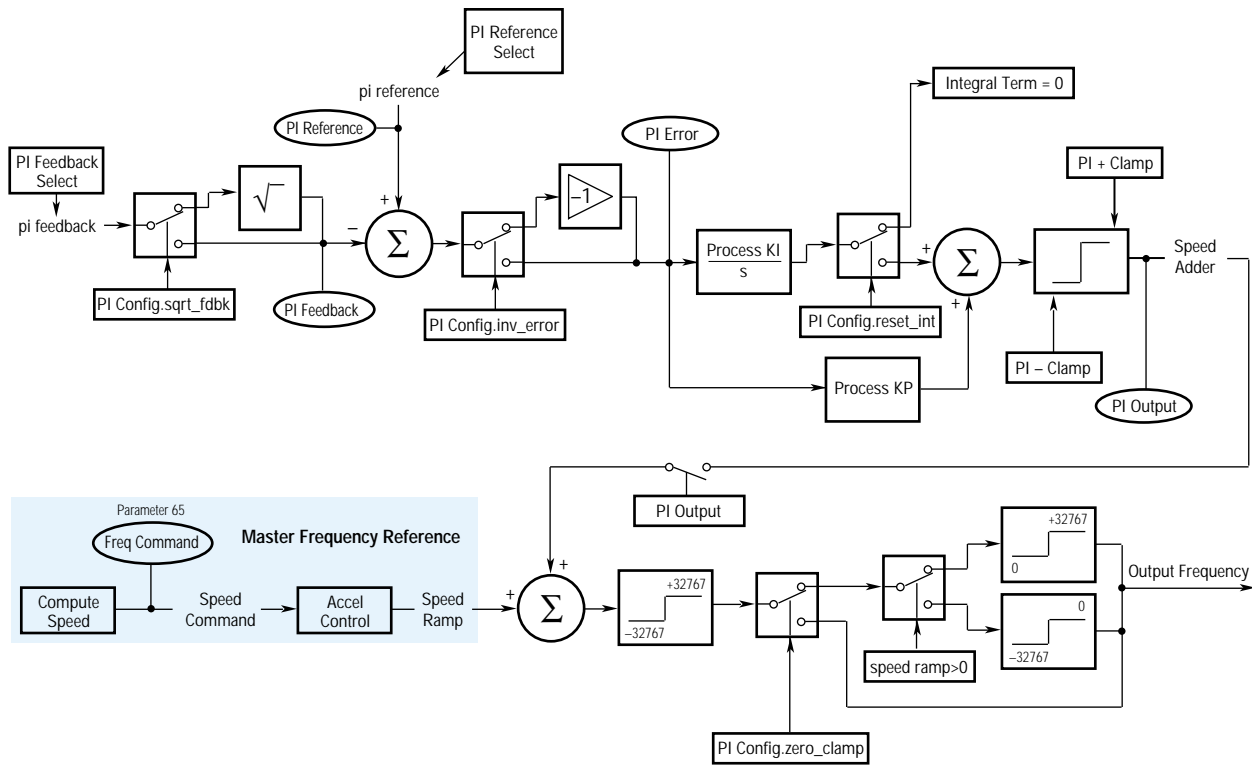
Parameter Number	224
Parameter Type	Read/Write
Display Units / Drive Units	0.01 Hertz / 32767 = Maximum Freq Forward
Factory Default	+8.33% of [Maximum Freq]
Minimum Value	-400.00 Hz
Maximum Value	400.00 Hz

Process PI

[PI Preload] – Firmware 4.01 & later

Sets the value used to preload the PI integrator when "Set Output" or "Preload Int" bits equal "1" in [PI Config].

Parameter Number	225
Parameter Type	Read/Write
Display Units / Drive Units	0.01 Hertz / ±32767 = Maximum Freq
Factory Default	0.00 Hz
Minimum Value	- 8.33% of [Maximum Freq]
Maximum Value	+ 8.33% of [Maximum Freq]



Motor Control

This group of parameters defines basic motor control and is only available with firmware version 4.01 and up.

[Control Select] – Firmware 4.01 & later

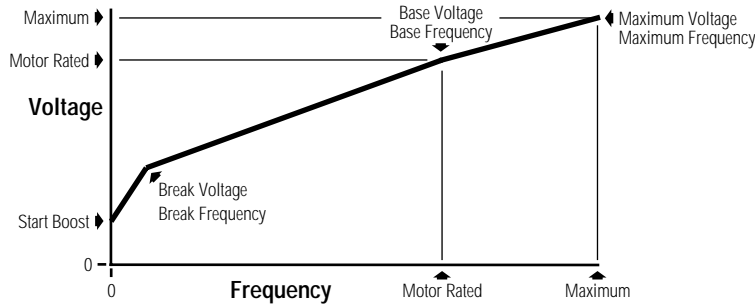
Selects the motor control method for the drive. The default setting provides full stator flux control that is suitable for most applications.

Additional selections are offered to optimally tune performance:

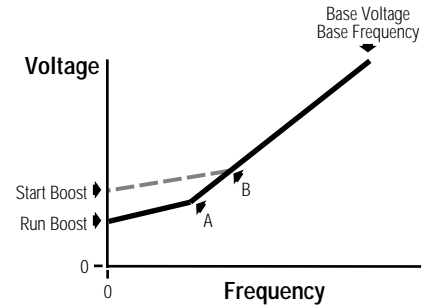
- Two volts/Hertz modes are available; one using simple voltage boost and one for complete configurability. These may be required for special motors or unmatched multi-motor installations.
- The Economize mode offers all the advantages of stator flux control plus the added feature of an "auto-economizer." If a motor remains lightly loaded for a specified period of time, the drive will attempt to reduce output voltage (and therefore output kW) in order to reduce the energy (operating) costs of the lightly loaded motor.

Parameter Number	9
Parameter Type	Read and Write
Factory Default	"Sens Vector"
Units	Display Drive
"Economize"	0 Stator Flux control with Economize
"Sens Vector"	1 Stator Flux control
"Fixed Boost"	2 V/Hz w/programmed accel/run boost
"Full Custom"	3 V/Hz with full configuration

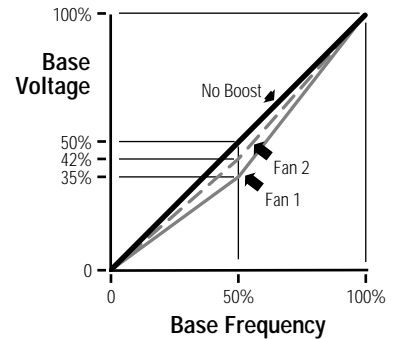
Full Custom



Fixed



Fan Select 1 & 2/No Boost



[Flux Amps Ref] – Firmware 4.01 & later

Used in Sensorless Vector mode only – Sets the value of amps required to maintain full motor flux. If set to zero, the drive will use an internal value based on [Motor NP Amps] and drive kW (HP). Refer to Chapter 4 for setup information.

Parameter Number	192
Parameter Type	Read and Write
Display Units / Drive Units	0.1 Amp / 4096 = Drive Rated Amps
Factory Default	0.0 Amps
Minimum Value	0.0 Amps
Maximum Value	75.0% of Drive VT Rated Amps

Motor Control

[IR Drop Volts] – <i>Firmware 4.01 & later</i> Used in Sensorless Vector mode only – Sets the value of volts dropped across the resistance of the motor stator. If set to zero, the drive will use an internal value based on motor F.L.A. and rated voltage. Some motors (i.e. 6 pole, special, etc.) may be particularly sensitive to the adjustment of this parameter. Refer to the tuning procedure in Chapter 4 for further information.	Parameter Number	194
	Parameter Type	Read and Write
	Display Units / Drive Units	1 Volt / 4096 = Drive Rated Volts
	Factory Default	0 Volts
	Minimum Value	0 Volts
	Maximum Value	25% of Drive Rated Volts

[Flux Up Time] – <i>Firmware 4.01 & later</i> Sets the amount of time the drive will use to try and achieve full motor stator flux. When a Start command is issued, DC current at current limit level is used to build stator flux before accelerating.	Parameter Number	200
	Parameter Type	Read and Write
	Display Units / Drive Units	0.1 Sec / Sec x 10
	Factory Default	0.0 Sec
	Minimum Value	0.0 Sec
	Maximum Value	5.0 Sec

[Start Boost] This parameter sets the DC start boost level for acceleration when [DC Boost Select] is set to "Fixed" or "Full Custom."	Parameter Number	48
	Parameter Type	Read and Write
	Display Units / Drive Units	1 Volt / 4096 = Drive Rtd Volts
	Factory Default	0 Volts
	Minimum Value	0 Volts
	Maximum Value	9.5% of Drive Rated Voltage

[Run Boost] This parameter sets the DC boost level for constant speed level when [DC Boost Select] is set to "Fixed".	Parameter Number	83
	Parameter Type	Read and Write
	Display Units / Drive Units	1 Volt / 4096 = Drive Rtd Volts
	Factory Default	0 Volts
	Minimum Value	0 Volts
	Maximum Value	9.5% of Drive Rated Voltage

[Boost Slope] – <i>Firmware 4.01 & later</i> Sets the slope of the volts/Hertz curve from zero Hertz to the intersect point (see Fixed boost diagram above). The slope is determined by multiplying: Run Boost x Boost Slope = A Start Boost x Boost Slope = B.	Parameter Number	169
	Parameter Type	Read and Write
	Display Units / Drive Units	None
	Factory Default	1.5
	Minimum Value	1.0
	Maximum Value	8.0

[Break Voltage] Sets the voltage the drive will output at [Break Frequency]. Combined with [Break Frequency], this parameter determines the volts-per-Hertz pattern between 0 and [Break Frequency].	Parameter Number	50
	Parameter Type	Read and Write
	Display Units / Drive Units	1 Volt / 4096 = Drive Rtd Volts
	Factory Default	25% of Drive Rated Voltage
	Minimum Value	0 Volts
	Maximum Value	50% of Drive Rated Voltage

[Break Frequency] This parameter sets a midpoint frequency on a custom volts-per-Hertz curve. Combined with [Break Voltage], this value determines the volts-per-Hertz ratio between 0 and [Break Frequency].	Parameter Number	49
	Parameter Type	Read and Write
	Display Units / Drive Units	1 Hertz / Hertz x 10 (x 1 frn < 4.01)
	Factory Default	25% of [Maximum Freq]
	Minimum Value	0 Hz
	Maximum Value	120 Hz

Important: Please note the resolution change with Frn 4.01.

Motor Control

[Base Voltage]

This value should be set to the motor nameplate rated voltage.

Parameter Number	18
Parameter Type	Read and Write
Display Units / Drive Units	1 Volt / 4096 = Drive Rtd Volts
Factory Default	Drive Rated Volts
Minimum Value	25% of Drive Rated Voltage
Maximum Value	120% of Drive Rated Voltage

[Base Frequency]

This value should be set to the motor nameplate rated frequency.

Parameter Number	17
Parameter Type	Read and Write
Display Units / Drive Units	1 Hertz / Hertz x 10 (x 1 frn < 4.01)
Factory Default	60 Hz
Minimum Value	25 Hz
Maximum Value	400 Hz

Important: Please note the resolution change with Frn 4.01.

[Maximum Voltage]

This parameter sets the highest voltage the drive will output.

Parameter Number	20
Parameter Type	Read and Write
Display Units / Drive Units	1 Volt / 4096 = Drive Rtd Volts
Factory Default	Drive Rated Volts
Minimum Value	25% of Drive Rated Voltage
Maximum Value	120% of Drive Rated Voltage

Linear List

This group lists all the parameters currently installed in your drive in numerical order. Refer to the Appendix at the back of this manual for an alpha/numeric listing of all parameters.

1336 PLUS Adjustable Frequency AC Drives with a Firmware Revision Number (FRN) of “5.xx.” have the following additional parameters:

[Power Dip Restart]

This parameter is only used with the two-wire control mode. If enabled, a 20 ms delay is added to the Start command when the Stop and Start commands are applied simultaneously following a power loss condition.

Parameter Number	241
Parameter Type	Read and Write
Factory Default	“Disabled”
Units	Display Drive
	“Disabled” 0
	“Enabled” 1

[Stability Gain]

This parameter adjusts the gain of the torque component of current to adjust for possible current instability in certain motors caused by variations in design. Increasing this value to the correct setting for a particular motor will stabilize torque pulsations in the motor.

Important: Setting this value too high may cause additional instability. It should be set for the lowest value that eliminates the instability.

Parameter Number	246
Parameter Type	Read and Write
Display Units / Drive Units	None
Factory Default	0
Minimum Value	0
Maximum Value	16

Troubleshooting

Chapter 6 provides information to guide the user in troubleshooting the 1336 PLUS. Included is a listing and description of the various drive faults (with possible solutions, when applicable) and alarms.

Fault Descriptions

Fault Display

The LCD display is used to indicate a fault by showing a brief text statement relating to the fault (see figure below). The fault will be displayed until “Clear Faults” is initiated or drive power is cycled. A Series A (version 3.0) or Series B HIM will display a fault when it occurs, no matter what state the display is in. In addition, a listing of past faults can be displayed by selecting “Fault queue” from the Control Status menu (see Chapter 3 for more information). Refer to Table 6.A for a listing and description of the various faults. Table 6.B provides a listing of faults by number.



Clearing a Fault

When a fault occurs, the cause must be corrected before the fault can be cleared. After corrective action has been taken, simply cycling drive power will clear the fault. Issuing a valid Stop command from the HIM or Control Interface option (TB3) will also clear a fault if the [Flt Clear Mode] parameter is set to “Enabled.” In addition, a “Clear Faults” command can be issued anytime from a serial device (if connected).

Contact Description

Refer to Figure 2.3 for a schematic representation of contacts CR1-CR4. Contacts in Figure 2.3 are shown in an unpowered state. When powered, the contacts will change state. For Example: During normal operating conditions (no faults present, drive running), the CR3 Fault contacts (default setting in firmware versions 4.01 & up) at TB2-13 & 14 are open, and the contacts at TB2-14 & 15 are closed. When a fault occurs, the state of these contacts will change.

Table 6.A
1336 PLUS Fault Descriptions

Name & Fault #	Description	Action
Adptr Freq Err 65	The SCANport adapter that was the selected frequency reference sent a frequency greater than 32767 to the drive.	Correct the problem that is causing the SCANport adapter to send the illegal frequency reference to the drive.
Auxiliary Fault 02	The auxiliary input interlock is open.	If Control Interface option is installed, check connections at TB3-24. If option is not installed, set [Input Mode] to "1."
BGND 10ms Over 51	Microprocessor loop fault. Occurs if the 10ms background task hasn't been run in 15 ms.	Replace Main Control Board or complete drive as required.
Blwn Fuse Flt 58	If the difference between the commanded voltage and the measured voltage is greater than 1/8 of rated voltage for 0.5 seconds, then a fault will be issued indicating that the bus fuse in 30 kW (40 HP) and up drives has blown.	Locate cause, replace fuse.
Diag C Lim Flt 36	The drive output current has exceeded the hardware current limit and the [Cur Lim Trip En] parameter was enabled.	Check programming of [Cur Lim Trip En] parameter. Check for excess load, improper DC boost setting, DC brake volts set too high or other causes of excess current.
Drive Fault Reset 22	Power-up has been attempted with an Open Stop contact or Closed Start contact.	Check/verify wiring and contact operation.
Drive -> HIM	Error 1 - The checksum read from the EEPROM does not match the checksum calculated from the EEPROM data.	Repeat operation. Replace HIM.
EE Init Read 53	1. Gate Drive Bd. replacement (requires re-initialization). 2. Trouble reading EEPROM during initialization.	1. Reset to factory defaults & cycle input power. 2. Check all connections to Power/Driver Board. Replace board or complete drive as needed.
EE Init Value 54	Stored parameter value out of range on initialization.	1. Reset to factory defaults & cycle input power. 2. Check all connections to the Power/Driver Bd. Replace the board or complete drive as needed.
EEprom Checksum 66	The checksum read from the EEPROM does not match the checksum calculated from the EEPROM data.	1. Reset to factory defaults & cycle input power. 2. Check all wire and cable connections to the Power Driver Board. Replace Power Driver Board or complete drive as required.
EEprom Fault 32	EEPROM is being programmed and will not write a new value.	Check all wire and cable connections to the Main Control Board. Replace Main Control Board or complete drive as required.
FGND 10ms Over 52	Microprocessor loop fault. Occurs if a 10ms interrupt is pending before the current interrupt is complete.	Replace Main Control Board or complete drive as required.

Name & Fault #	Description	Action
Ground Fault 13	A current path to earth ground in excess of 100A has been detected at one or more of the drive output terminals. NOTE: If ground current exceeds 220% of drive rated current, "Overcurrent Flt" may occur instead of Ground Fault.	Check the motor and external wiring to the drive output terminals for a grounded condition.
Ground Warning 57	A current path to earth ground in excess of 2A has been detected at one or more of the drive output terminals. See [Ground Warning].	Check the motor and external wiring to the drive output terminals for a grounded condition.
Hertz Err Fault 29	This fault indicates that there is not a valid operating frequency. It can be caused by any of the following: 1. [Maximum Freq] is less than [Minimum Freq]. 2. Skip frequencies and skip bandwidth eliminate all operating frequencies. 3. 4-20mA input signal speed reference has been lost and [4-20mA Loss Sel] is set for "Stop-Fault."	1. Check [Minimum Freq] and [Maximum Freq] parameters. 2. Check [Skip Freq 1], [Skip Freq 2], [Skip Freq 3] and [Skip Freq Band] parameters. 3. Check for broken wires, loose connections or transducer loss at 4-20mA input, TB2.
Hertz Sel Fault 30	A frequency select parameter has been programmed with an out of range value.	Reprogram [Freq Select 1] and/or [Freq Select 2] with a correct value. If problem persists, replace Main Control Board or complete drive.
HIM -> Drive	Error 1 – The checksum read from the EEPROM does not match the checksum calculated from the EEPROM data. Error 2 – Number of parameters in saved profile does not equal master. Error 3 – Download was attempted to a different type drive (i.e. 1336->1305). Error 4 – Saved data not correct for new drive. Error 5 – Drive is running while attempting download.	Retry download. Replace HIM. Retry download. Replace HIM. Download can only take place with same type drive. Capabilities of drive different then master drive. Reprogram param. Stop drive, then perform download.
Loop Overrn Flt 23	An overrun of the 2.5ms control loop has occurred.	Check all connections to the Power/Driver Board. Replace the board or complete drive as needed.
Max Retries Fault 33	Drive unsuccessfully attempted to reset a fault and resume running for the programmed number of [Reset/Run Tries].	Check fault buffer for fault code requiring reset. Correct the cause of the fault and manually clear by pressing the local Stop key or cycling the TB3 Stop input.
Motor Mode Flt 24	A fault has been detected originating from the Control Board.	Check all connections to the Control Board. Replace the board, Language Module or complete drive as required.

Name & Fault #	Description	Action
Motor Stall Fault 06	Current remained over 150% of [Rated Amps] for more than 4 seconds.	If the motor is drawing excessive current (over 150%), the motor load is excessive and will not allow the drive to accelerate to set speed. A longer accel time or a reduced load may be required.
Neg Slope Fault 35	Drive software detected a portion of the volts/hertz curve with a negative slope.	Check drive programming. *1. [Maximum Voltage] parameter must be greater than [Base Voltage]. *2. [Maximum Freq] parameter must be greater than [Base Frequency]. 3. [Base Voltage] parameter must be greater than [Start Boost]. 4. If the [DC Boost Select] parameter is set to "Full Custom," [Base Voltage] must be greater than [Break Voltage] and [Break Voltage] must be greater than [Start Boost]. <i>* Firmware versions before 2.01 only.</i>
Open Pot Fault 09	An external pot is connected and the common side of the pot is open. The drive generates this fault when the voltage between TB2-2 and TB2-3 exceeds 3.9V DC.	Check the external potentiometer circuit at TB2, terminals 1, 2 and 3 for an open circuit.
Op Error Fault 11	A SCANport device requests a Read or Write of a data type not supported. This will also occur if: 1. [Motor Type] is set to "Sync PM" and [Stop Mode Used] is set to "DC Brake", or 2. [Motor Type] is set to "Sync Reluc" or "Sync PM" and [Speed Control] is set to "Slip Comp".	Check programming.
Overcurrent Flt 12	Overcurrent is detected in instantaneous overcurrent trip circuit.	Check for a short circuit at the drive output or excessive load conditions at the motor.
Overload Fault 07	Internal electronic overload trip.	An excessive motor load exists. It must be reduced such that drive output current does not exceed the current set by the [Overload Amps] parameter.
Overtemp Fault 08	Heat sink temperature exceeds a predefined value of 90° C (195° F).	Check for blocked or dirty heat sink fins. Check that the ambient temperature has not exceeded 40° C (104° F).
Overvolt Fault 05	DC bus voltage exceeded maximum value.	Monitor the AC line for high line voltage or transient conditions. Bus overvoltage can also be caused by motor regeneration. Extend the decel time or install dynamic brake option.
Phase U Fault 38	A phase to ground fault has been detected between the drive and motor in this phase.	Check the wiring between the drive and motor. Check motor for grounded phase.

Name & Fault #	Description	Action
Phase V Fault 39	A phase to ground fault has been detected between the drive and motor in this phase.	Check the wiring between the drive and motor. Check motor for grounded phase.
Phase W Fault 40	A phase to ground fault has been detected between the drive and motor in this phase.	Check the wiring between the drive and motor. Check motor for grounded phase.
P Jump Err Flt 37	Reserved for future use.	
Poles Calc Flt 50	Generated if the calculated value of [Motor Poles] is less than 2 or greater than 32.	Check [Motor NP RPM] and [Motor NP Hertz] programming.
Power Loss Fault 03	DC bus voltage remained below 85% of nominal for longer than 500ms. [Line Loss Fault] parameter is set to "enabled."	Monitor the incoming AC line for low voltage or line power interruption.
Power Mode Fault 26	The internal power mode variable received an incorrect value.	Check all connections to the Control Board. Replace the board, Language Module or complete drive as required.
Power Overload 64	The drive rating of 150% for 1 minute has been exceeded.	Reduce load.
Power Test Flt 46	The internal power mode variable received an incorrect value.	Check all connections to the Power/Driver Board. Replace the board or complete drive as needed.
Precharge Fault 19	The precharge device was open 20ms after the end of a line loss condition or the bus charging alarm remains on for 20 seconds (precharge did not complete).	See Chapter 1 for frame definitions. 1. Frames A1, A2, A3 – Check the precharge circuit. Replace the precharge NTC or complete drive as needed. 2. Frame B – Check the precharge circuit. Replace the precharge transistor, Power Driver Board or complete drive as required. 3. All larger frames – Check the precharge circuit. Replace the input SCRs, SCR Firing Board, Power Driver Board or complete drive as needed.
Precharge Open 56	The precharge circuit was commanded to close, but was detected to be open.	See page 1-1 for frame definitions. 1. Frames A1, A2, A3 – Check the precharge circuit. Replace the precharge NTC or complete drive as needed. 2. Frame B – Check the precharge circuit. Replace the precharge transistor, Power Driver Board or complete drive as required. 3. All larger frames – Check the precharge circuit. Replace the input SCRs, SCR Firing Board, Power Driver Board or complete drive as needed.

Name & Fault #	Description	Action
Reprogram Fault 48	The drive was commanded to write default values to EEPROM.	<ol style="list-style-type: none"> 1. Clear the fault or cycle power to the drive. 2. Program the drive parameters as needed. <p>Important: If [Input Mode] has been changed from its original value, power must be cycled before the new value will take affect.</p>
ROM or RAM Flt 68	Internal power-up ROM or RAM tests have not executed properly.	Check Language Module. Replace Control Board or complete drive as required.
Run Boost Fault 34	An attempt has been made to set the [Run Boost] parameter to a value greater than the [Start Boost] parameter.	Verify that parameter has been programmed correctly.
Serial Fault 10	A SCANport adapter has been disconnected and the [Logic Mask] bit for that adapter is set to "1."	<ol style="list-style-type: none"> 1. If no adapter was intentionally disconnected, check wiring to the SCANport adapters. Replace wiring, SCANport expander, SCANport adapters, Main Control Board or complete drive as required. 2. If an adapter was intentionally disconnected and the [Logic Mask] bit for that adapter is set to "1", this fault will occur. To guard against this fault occurring, set the [Logic Mask] bit for the adapter to "0."
Shear Pin Fault 63	Programmed [Current Limit] amps has been exceeded and [Shear Pin Fault] is enabled.	Check load requirements and [Current Limit] setting.
Temp Sense Open 55	Heat sink thermistor is open or malfunctioning.	Check thermistor and connections.
Undervolt Fault 04	DC Bus voltage fell below the minimum value (388V DC at 460V AC input). [Line Loss Fault] and [Low Bus Fault] set to "enabled."	Monitor the incoming AC line for low voltage or line power interruption.
UV Short Fault 41	Excessive current has been detected between these two output terminals.	Check the motor and external wiring to the drive output terminals for a shorted condition.
UW Short Fault 42	Excessive current has been detected between these two output terminals.	Check the motor and external wiring to the drive output terminals for a shorted condition.
VW Short Fault 43	Excessive current has been detected between these two output terminals.	Check the motor and external wiring to the drive output terminals for a shorted condition.
Xsistr Desat Flt 47 (Frame Size C & Above)	One or more of the output transistors were operating in the active region instead of desaturation. This can be caused by excessive transistor current or insufficient base drive voltage.	Check for damaged output transistors. Replace output transistors, Power Driver Board or complete drive as needed.

Table 6.B
Fault Code Cross Reference

Fault #	Display Name	Reset/Run
02	Auxiliary Fault	Yes
03	Power Loss Fault	Yes
04	Undervolt Fault	Yes
05	Overvolt Fault	Yes
06	Motor Stall Fault	Yes
07	Overload Fault	Yes
08	Overtemp Fault	Yes
09	Open Pot Fault	No
10	Serial Fault	No
11	Op Error Fault	No
12	Overcurrent Flt	Yes
13	Ground Fault	No
19	Precharge Fault	No
22	Drive Fault Reset	Yes
23	Loop Overrn Flt	Yes
24	Motor Mode Flt	Yes
26	Power Mode Fault	Yes
28	Timeout Fault	No
29	Hertz Err Fault	No
30	Hertz Sel Fault	No
31	Timeout Fault	No
32	EEprom Fault	No
33	Max Retries Fault	No
34	Run Boost Fault	No
35	Neg Slope Fault	No
36	Diag C Lim Flt	No
37	P Jump Err Flt	No
38	Phase U Fault	No
39	Phase V Fault	No
40	Phase W Fault	No
41	UV Short Fault	No
42	UW Short Fault	No
43	VW Short Fault	No
46	Power Test Flt	No
47	Xsistr Desat Flt	No
48	Reprogram Fault	No
50	Pole Calc Fault	No
51	BGND 10ms Over	Yes
52	FGND 10ms Over	Yes
53	EE Init Read	No
54	EE Init Value	No
55	Temp Sense Open	No
56	Precharge Open	No
57	Ground Warning	No
58	Blwn Fuse Flt	No
59-62	Reserved for Future Use	
63	Shear Pin Fault	No
64	Power Overload	No
65	Adptr Freq Err	No
66	EEprom Checksum	No
68	ROM or RAM Flt	No

Alarms

Table 6.C presents a listing and description of the drive alarms. Alarm status can be viewed by selecting the [Drive Alarm] parameter. An active alarm will be indicated by its corresponding bit being set to high (1). Any high bit (1) will energize CR4 (see figure 2.3).

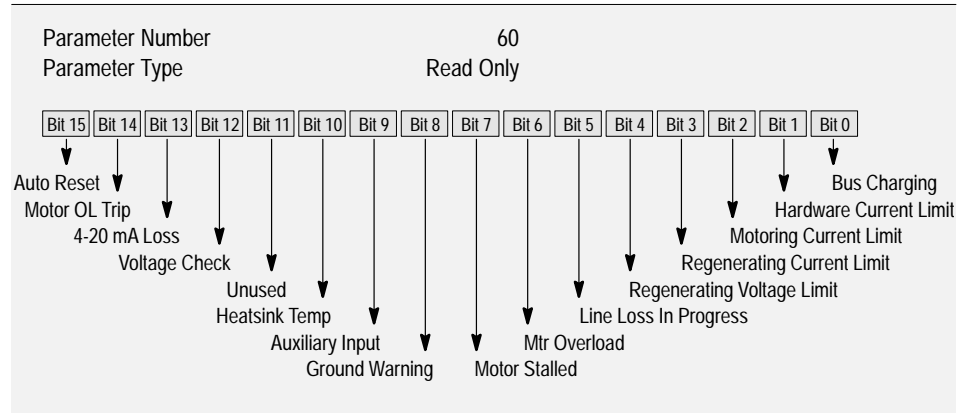


Table 6.C
Alarm Conditions

Alarm Name	Description
Bus Charging	Precharge of DC bus capacitors is in progress.
Hardware Current Limit	An alarm will be issued when 220% of drive rated current is reached.
Motoring Current Limit	The value programmed for [Current Limit] has been exceeded while in the motoring mode.
Regenerating Current Limit	An alarm will be issued when the value set for [Current Limit] has been exceeded while the motor is regenerating.
Regenerating Voltage Limit	Bus limiting is active.
Line Loss In Progress	An alarm will be issued when the AC incoming voltage drops below 20% of input or a 150 volt drop takes place.
Mtr Overload	At the present value of output amps, a motor overload trip will eventually occur.
Motor Stalled	The drive output frequency folds to 0 Hz and current limit is still active or voltage limit will not allow decel.
Ground Warning	Ground current exceeds 2 amperes.
Auxiliary Input	TB3 terminal 24 circuit is open.
Heatsink Temp	Temperature of drive heatsink has exceeded its limit.
Voltage Check	Voltage at drive output terminals is equal to, or greater than 10% of drive rated volts (i.e. 46V for 460V drive) when Start command is issued and flying start is disabled. Drive will not start until terminal voltage falls below 10% of drive rating or flying start is enabled.
4-20mA Loss	4-20mA signal lost.
Motor OL Trip	This bit will be high when the motor overload function has integrated high enough to cause a motor overload fault. This bit is active regardless of the [Motor Overload] state (enabled/disabled).
Auto Reset	Drive is attempting to reset a fault using [Reset/Run Tries] & [Reset/Run Time].

Specifications and Supplemental Information

Appendix A provides specifications and supplemental information including a parameter cross reference and derate information.

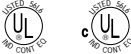

Specifications

Protection

	<u>200-240V Drive</u>	<u>380-480V Drive</u>	<u>500-600V Drive</u>
AC Input Overvoltage Trip:	285V AC	570V AC	690V AC
AC Input Undervoltage Trip:	138V AC	280V AC	343V AC
Bus Overvoltage Trip:	405V DC	810V DC	975V DC
Bus Undervoltage Trip:	200V DC	400V DC	498V DC
Nominal Bus Voltage:	324V DC	648V DC	810V DC
Heat Sink Thermistor:	Monitored by microprocessor overtemp trip.		
Drive Overcurrent Trip			
Software Current Limit:	20 to 160% of VT rated current.		
Hardware Current Limit:	180 to 250% of VT rated current (dependent on drive rating).		
Instantaneous Current Limit:	220 to 300% of VT rated current (dependent on drive rating).		
Line transients:	up to 6000 volts peak per IEEE C62.41-1991.		
Control Logic Noise Immunity:	Showering arc transients up to 1500 volts peak ² .		
Power Ride-Thru:	15 milliseconds at full load.		
Logic Control Ride-Thru:	0.5 seconds minimum, 2 seconds typical.		
Ground Fault Trip:	Phase-to-ground on drive output.		
Short Circuit Trip:	Phase-to-phase on drive output.		

Environment

Altitude:	1000 m (3300 ft) max. without derating.
Ambient Operating Temperature	
IP00, Open:	0 to 50 degrees C (32 to 122 degrees F).
IP20, NEMA Type 1 Enclosed:	0 to 40 degrees C (32 to 104 degrees F).
IP54, NEMA Type 12 Enclosed:	0 to 40 degrees C (32 to 104 degrees F).
IP65, NEMA Type 4 Enclosed:	0 to 40 degrees C (32 to 104 degrees F).
Storage Temperature (all constructions):	-40 to 70 degrees C (-40 to 158 degrees F).
Relative Humidity:	5 to 95% non-condensing.
Shock:	15G peak for 11ms duration (±1.0ms).
Vibration:	0.006 inches (0.152 mm) displacement, 1G peak.
Agency Certification:	

U.L. Listed CSA Certified	
Marked for all applicable directives ¹	
Emissions	
EN 50081-1	
EN 50081-2	
EN 55011 Class A	
EN 55011 Class B	
Immunity	
EN 50082-1	
EN 50082-2	
IEC 801-1, 2, 3, 4, 6, 8 per EN 50082-1, 2	
Low Voltage	
EN 60204-1	
PREN 50178	

¹ Note: Installation guidelines called out in *Appendix C* must be adhered to.

² Excludes Pulse Train Input.

Electrical

Input Data

Voltage Tolerance:	-10% of minimum, +10% of maximum.
Frequency Tolerance:	48-62 Hz.
Input Phases:	Three-phase input provides full rating for all drives. Single-phase operation is possible for A & B Frame drives at a derating of 50%.

Displacement Power Factor

A1-A3 Frame Drives:	0.80 standard, 0.95 with optional inductor.
A4 Frame & Up Drives:	0.95 standard.

Efficiency: 97.5% at rated amps, nominal line volts.

Max. Short Circuit Current Rating: 200,000A rms symmetrical, 600 volts (when used with AC input line fuses specified in Chapter 2).

Control

Method: Sine coded PWM with programmable carrier frequency. Ratings apply to all drives (refer to the *Derating Guidelines* on page A-5).

A Frame Drives	2-10 kHz. Drive rating based on 4 kHz (see pg. 1-1 for frame info).
B Frame Drives	2-8 kHz. Drive rating based on 4 kHz (see pg. 1-1 for frame info).
C & D Frame Drives	2-6 kHz. Drive rating based on 4 kHz (see pg. 1-1 for frame info).
E Frame Drives & Up	2-6 kHz. Drive rating based on 2 kHz (see pg. 1-1 for frame info).

Output Voltage Range: 0 to rated voltage.

Output Frequency Range: 0 to 400 Hz.

Frequency Accuracy

Digital Input:	Within $\pm 0.01\%$ of set output frequency.
Analog Input:	Within $\pm 0.4\%$ of maximum output frequency.

Selectable Motor Control: Sensorless Vector with full tuning. Standard V/Hz with full custom capability.

Accel/Decel: Two independently programmable accel and decel times. Each time may be programmed from 0 - 3600 seconds¹ in 0.1 second increments².

Intermittent Overload: Constant Torque – 150% of rated output for 1 minute.
Variable Torque – 115% of rated output for 1 minute.

Current Limit Capability: Proactive Current Limit programmable from 20 to 160% of rated output current. Independently programmable proportional and integral gain.

Inverse Time Overload Cap. Class 10 protection with speed sensitive response. Investigated by U.L. to comply with N.E.C. Article 430. U.L. File E59272, volume 4/6.

¹ 600 seconds with Firmware Versions before 4.01.

² 0.1 second increments using a HIM or 0.01 with serial communications.

Input/Output Ratings

Each 1336 PLUS Drive has constant and variable torque capabilities. The listings on the next page provide input & output current and kVA ratings.

Note: Drive ratings are at nominal values. See *Derating Guidelines* on page A-5.

Cat. No.	Constant Torque				Variable Torque			
	Input kVA	Input Amps	Output kVA	Output Amps	Input kVA	Input Amps	Output kVA	Output Amps
200-240V DRIVES								
AQF05	1.1	2.8	0.9	2.3	1.1	2.8	0.9	2.3
AQF07	1.4	3.5	1.2	3.0	1.4	3.5	1.2	3.0
AQF10	2.2	5.4	1.8	4.5	2.2	5.4	1.8	4.5
AQF15	2.9	7.3	2.4	6.0	2.9	7.3	2.4	6.0
AQF20	3.9	9.7	3.2	8.0	3.9	9.7	3.2	8.0
AQF30	5.7	14.3	4.8	12	5.7	14.3	4.8	12
AQF50	8.5	21.3	7.2	18	8.5	21.3	7.2	18
A007	10-12	28	11	27	10-12	28	11	27
A010	12-14	35	14	34	12-14	35	14	34
A015	17-20	49	19	48	17-20	49	19	48
A020	22-26	63	26	65	22-26	63	26	65
A025	26-31	75	31	77	26-31	75	31	77
A030	27-33	79	32	80	27-33	79	32	80
A040	41-49	119	48	120	41-49	119	48	120
A050	52-62	149	60	150	52-62	149	60	150
A060	62-74	178	72	180	62-74	178	72	180
A075	82-99	238	96	240	82-99	238	96	240
A100	100-120	289	116	291	100-120	289	116	291
A125	112-134	322	129	325	112-134	322	129	325
380-480V DRIVES								
BRF05	0.9-1.0	1.3	0.9	1.1	0.9-1.1	1.4	1.0	1.2
BRF07	1.3-1.6	2.0	1.3	1.6	1.4-1.7	2.1	1.4	1.7
BRF10	1.7-2.1	2.6	1.7	2.1	1.8-2.2	2.8	1.8	2.3
BRF15	2.2-2.6	3.3	2.2	2.8	2.3-2.8	3.5	2.4	3.0
BRF20	3.0-3.7	4.6	3.0	3.8	3.2-3.8	4.8	3.2	4.0
BRF30	4.2-5.1	6.4	4.2	5.3	4.7-5.7	7.2	4.8	6.0
BRF50	6.6-8.0	10.0	6.7	8.4	7.0-8.5	10.7	7.2	9.0
BRF75	9.5-11.6	14.5	11.2	14.0	12.2-14.7	18.5	13.9	17.5
BRF100	12.2-14.7	18.5	13.9	17.5	17.1-20.7	26.0	19.9	25.0
B007	8-11	13	10	12.5	9-12	14	11	14
B010	11-14	17	13	16.1	14-18	22	17	21
B015	16-21	25	19	24.2	18-23	28	22	27
B020	21-26	32	25	31	23-29	35	27	34
B025	26-33	40	31	39	28-36	43	33	42
B030	30-38	46	36	45	32-41	49	38	48
BX040	40-50	61	47	59	40-50	61	47	59
B040	38-48	58	48	60	41-52	63	52	65
B050	48-60	73	60	75	49-62	75	61	77
BX060 ¹	62	75	61	77	62	75	61	77
B060	54-68	82	68	85	61-77	93	76	96
B075	69-87	105	84	106	78-99	119	96	120
B100	90-114	137	110	138	98-124	149	120	150
B125	113-143	172	138	173	117-148	178	143	180
BX150	148	178	143	180	148	178	143	180
B150	130-164	197	159	199	157-198	238	191	240
B200	172-217	261	210	263	191-241	290	233	292
B250	212-268	322	259	325	212-268	322	259	325
BP250	212-268	322	259	325	235-297	357	287	360
BX250	212-268	322	259	325	228-288	347	279	360
B300	228-288	347	279	360	261-330	397	319	425
BP300	235-297	357	287	360	277-350	421	339	425
B350	261-330	397	319	425	294-371	446	359	475
BP350	277-350	421	339	425	310-392	471	378	475
B400	294-371	446	359	475	326-412	496	398	525
BP400	310-392	471	378	475	347-438	527	424	532
B450	326-412	496	398	525	372-470	565	454	590
BP450	347-438	527	424	532	347-438	527	424	532
B500	372-470	565	454	590	437-552	664	534	670
B600	437-552	664	534	670	437-552	664	534	670
500-600V DRIVES								
CWF10	2.1-2.5	2.4	2.1	2.0	2.1-2.5	2.4	2.1	2.0
CWF20	4.2-5.0	4.8	4.2	4.0	4.2-5.0	4.8	4.2	4.0
CWF30	6.2-7.5	7.2	6.2	6.0	6.2-7.5	7.2	6.2	6.0
CWF50	8.3-10.0	9.6	8.3	8.0	8.3-10.0	9.6	8.3	8.0
C007	9-11	10	10	10	9-11	10	10	10
C010	11-13	12	12	12	11-13	12	12	12
C015	17-20	19	19	19	17-20	19	19	19
C020	21-26	25	24	24	21-26	25	24	24
C025	27-32	31	30	30	27-32	31	30	30
C030	31-37	36	35	35	31-37	36	35	35
C040	38-45	44	45	45	38-45	44	45	45
C050	48-57	55	57	57	48-57	55	57	57
C060	52-62	60	62	62	52-62	60	62	62
C075	73-88	84	85	85	73-88	84	85	85
C100	94-112	108	109	109	94-112	108	109	109
C125	118-142	137	137	138	118-142	137	137	138
C150 ²	144-173	167	167	158	144-173	167	167	158
C200 ²	216-260	250	252	252	216-260	250	251	252
C250	244-293	282	283	284	244-293	282	283	284
CX300	256-307	295	297	300	256-307	295	297	300
C300	258-309	297	299	300	258-309	297	299	300
C350	301-361	347	349	350	301-361	347	349	350
C400	343-412	397	398	400	343-412	397	398	400
C450 ²	386-464	446	448	450	386-464	446	448	450
C500 ²	429-515	496	498	500	429-515	496	498	500
C600 ²	515-618	595	598	600	515-618	595	598	600

¹ 480 Volts Only.² In firmware versions 2.04 and below, the factory default PWM frequency is 4 kHz. Drive must be reprogrammed to 2 kHz to achieve current ratings listed.

User Supplied Enclosures

1336 plus drives installed in user supplied enclosures may be mounted within an enclosure or may be mounted to allow the heat sink to extend outside the enclosure. Use the information below in combination with the enclosure manufacturer's guidelines for sizing.

Cat No.	Base Derate Amps ¹	Derate Curve ^{2,3}	Heat Dissipation Drive Watts ^{2,3,4}	Heat Sink Watts ²	Total Watts ²
200-240V DRIVES					
AQF05	2.3	Figure A	13	15	28
AQF07	3.0	Figure A	15	21	36
AQF10	4.5	Figure A	17	32	49
AQF15	6.0	Figure A	21	42	63
AQF20	8.0	Figure A	25	56	81
AQF30	12	Figure A	33	72	105
AQF50	18	Figure A	42	116	158
A007	27	None	156	486	642
A010	34	Figure B	200	721	921
A015	48	Figure D	205	819	1024
A020	65	None	210	933	1143
A025	77	None	215	1110	1325
A030	80	None	220	1110	1330
A040	120	Figure G	361	1708	2069
A050	150	Figure H	426	1944	2370
A060	180	Figure J	522	2664	3186
A075	240	Figure L	606	2769	3375
A100	291	Figure M	755	3700	4455
A125	325	Figure N	902	4100	5002
380-480V DRIVES					
BRF05	1.2	Figure A	12	9	21
BRF07	1.7	Figure A	13	15	28
BRF10	2.3	Figure A	15	20	35
BRF15	3.0	Figure A	16	27	43
BRF20	4.0	Figure A	19	36	55
BRF30	6.0	Figure A	23	54	77
BRF50	9.0	Figure A	29	84	113
BRF75	17.5	Figure A	70	230	300
BRF100	25.0	Figure A	89	331	420
B007	14	None	91	270	361
B010	21	None	103	394	497
B015	27	None	117	486	603
B020	34	Figure B	140	628	768
B025	42	Figure C	141	720	861
B030	48	Figure D	141	820	961
BX040	59	Figure E	175	933	1108
B040	65	Figure E	175	933	1108
B050	77	Figure F	193	1110	1303
BX060	77	Figure F	193	1110	1303
B060	96	None	361	1708	2069
B075	120	Figure G	361	1708	2069
B100	150	Figure H	426	1944	2370
B125	180	Figure J	522	2664	3186
BX150	180	Figure J	606	2769	3375
B150	240	Figure L	606	2769	3375
B200	292	Figure M	755	3700	4455
B250	325	Figure N	902	4100	5002
BP250	322	Figure O	491	4658	5149
BX250	360	None	902	4100	5002
B300	425	None	1005	4805	5810
BP300	357	Figure P	619	5342	5961
B350	475	None	1055	5455	6510
BP350	421	Figure Q	733	6039	6772
B400	525	None	1295	6175	7470
BP400	471	Figure R	793	6329	7122
B450	590	None	1335	6875	8210
BP450	527	Figure S	931	7000	7931
B500 ⁵	670	Figure T	1395	7525	8920
B600 ⁵	670	Figure T	1485	8767	10252
500-600V DRIVES					
CW10	2.4	Figure U	25	29	54
CW20	4.8	Figure U	29	57	86
CW30	7.2	Figure U	32	87	119
CW50	9.6	Figure U	35	117	152
C007	10	None	91	217	308
C010	12	None	103	251	354
C015	19	None	117	360	477
C020	24	None	140	467	607
C025	30	None	141	492	633
C030	35	None	141	526	667
C040	45	None	175	678	853
C050	57	None	193	899	1092
C060	62	⁶	193	981	1174
C075	85	Figure G	361	1533	1894
C100	109	Figure I	426	1978	2404
C125	138	Figure K	522	2162	2683
C150	158	Figure V	606	2315	2921
C200	252	Figure W	755	3065	3820
C250	284	Figure X	890	3625	4515
CX300	300	Figure Y	940	3990	4930
C300 ⁵	300	Figure Z/AA	926	5015	5941
C350 ⁵	350	Figure Z/AA	1000	5935	6935
C400 ⁵	400	Figure Z/AA	1430	7120	8550
C450 ⁵	450	Figure Z/AA	1465	8020	9485
C500 ⁵	500	Figure Z/AA	1500	8925	10425
C600 ⁵	600	Figure Z/AA	1610	10767	12377

- Base Derate Amps are based on nominal voltage (240, 480 or 600V). If input voltage exceeds Drive Rating, Drive Output must be derated. Refer to **Figure CC**.
- Rating is at 4 kHz (2 kHz for 224-448 kW/300-600 HP, 500-600V). If carrier frequencies above 4 kHz are selected, drive rating must be derated. See **Figures A-AA**.
- Drive Ambient Temperature Rating is 40° C. If ambient exceeds 40° C, the drive must be derated. Refer to **Figures A-AA**.
- Drive Rating is based on altitudes of 1,000 m (3,000 ft) or less. If installed at higher altitude, drive must be derated Refer to **Figure BB**.
- Important:** Two (2) 725 CFM fans are required if an open type drive is mounted in a user supplied enclosure.
- Not available at time of printing.

Derating Guidelines

Drive ratings can be affected by a number of factors. If more than one factor exists, derating percentages must be multiplied. For example, if a 42 Amp drive (B025) running at 8 kHz is installed at a 2,000 m (6,600 ft.) altitude and has a 2% high input line voltage, the actual amp rating will be:

$$42 \times 94\% \text{ Altitude Derate} \times 96\% \text{ High Line Derate} = 37.9 \text{ Amps.}$$

AMBIENT TEMPERATURE / CARRIER FREQUENCY

— Standard Rating for Enclosed Drive in 40°C Ambient & Open Drive in 50°C Ambient. — Derating Factor for Enclosed Drive in Ambient between 41°C & 50°C.

Figure A
AQF05-AQF50 and BRF05-BRF100

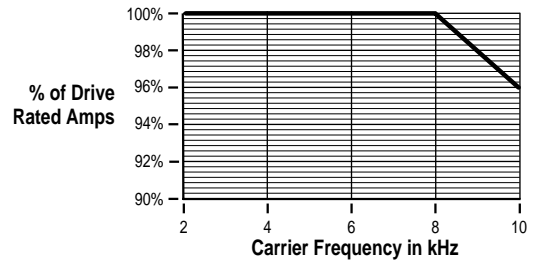


Figure B
1336S-A010 and B020

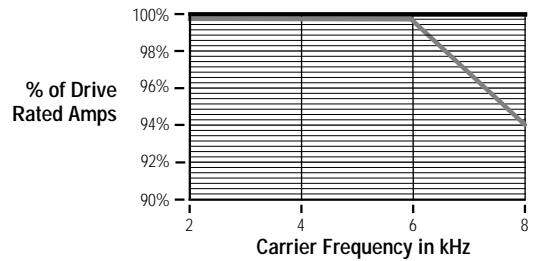


Figure C
1336S-B025

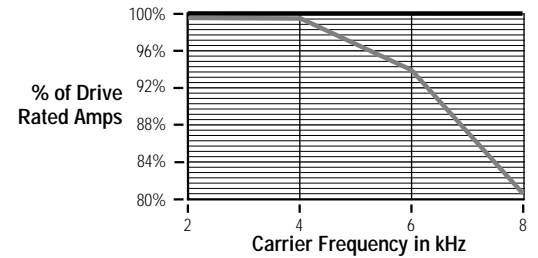


Figure D
1336S-A015 and B030

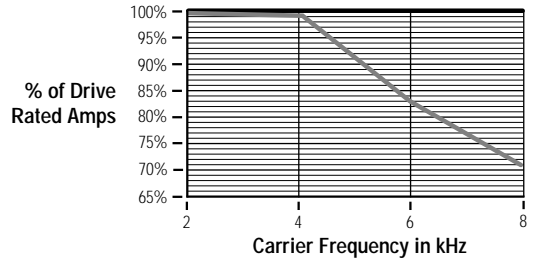


Figure E
1336S-B040 and BX040

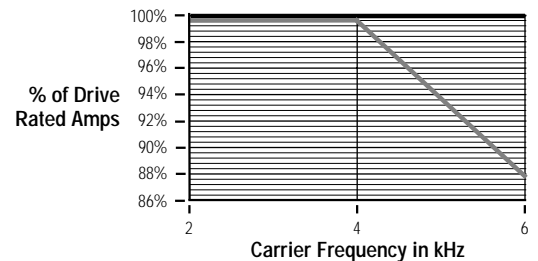


Figure F
1336S-B050 and BX060

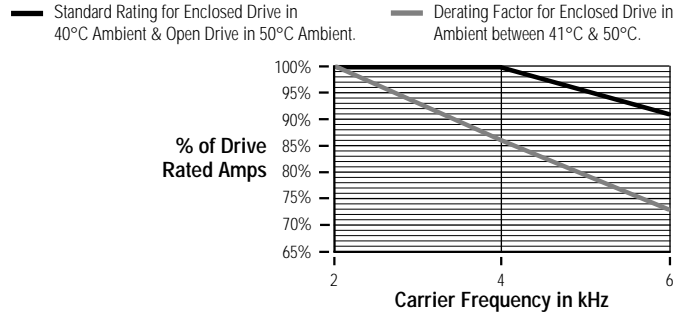


Figure G
1336S-A040, B075, C075

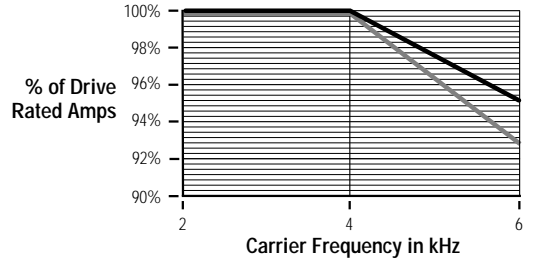


Figure H
1336S-A050, B100

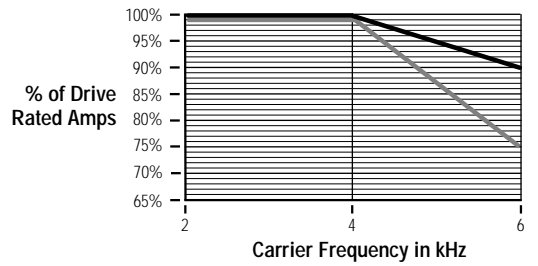


Figure I
1336S-C100

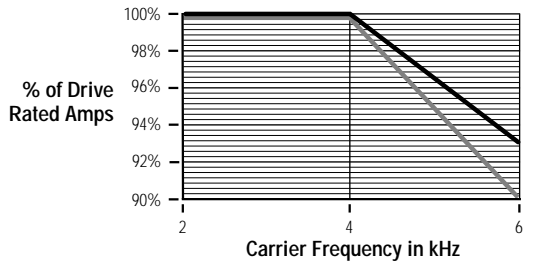


Figure J
1336S-A060, B125, BX150

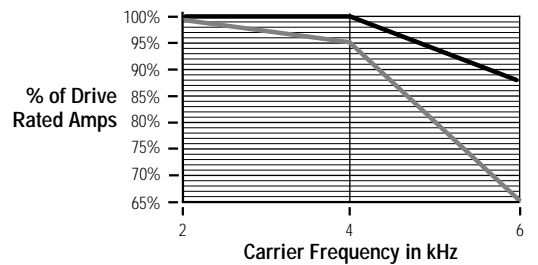


Figure K
1336S-C125

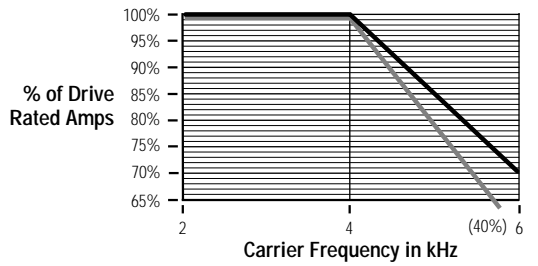


Figure L
1336S-A075, B150

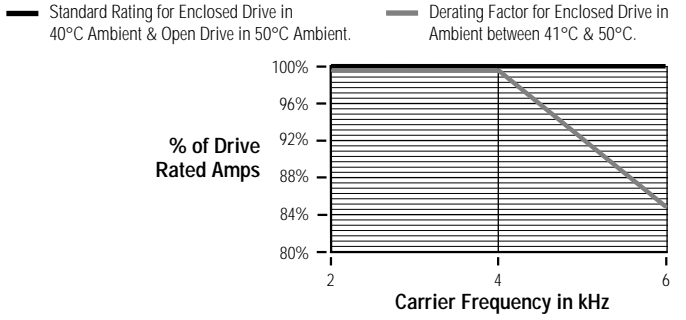


Figure M
1336S-A100, B200

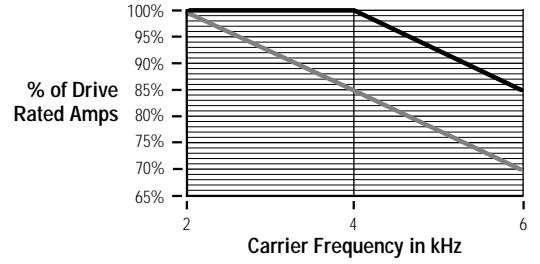


Figure N
1336S-A125, B250

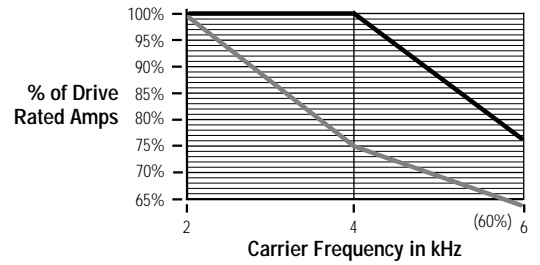


Figure O
1336S-BP250

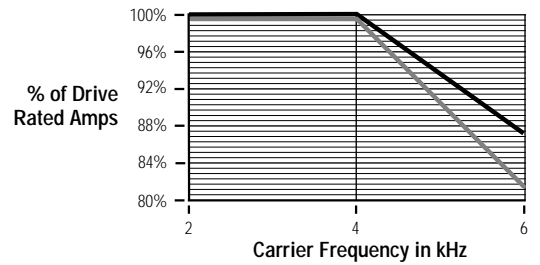


Figure P
1336S-BP300

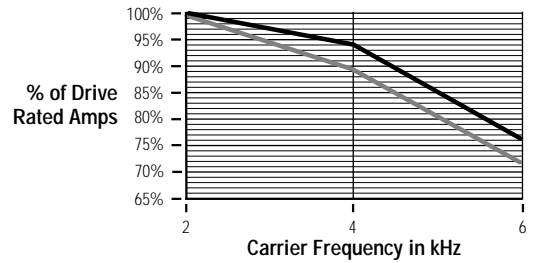
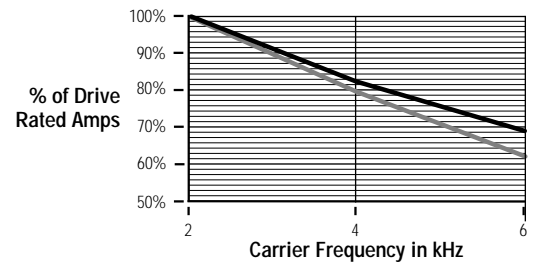


Figure Q
1336S-BP350



— Standard Rating for Enclosed Drive in 40°C Ambient & Open Drive in 50°C Ambient. — Derating Factor for Enclosed Drive in Ambient between 41°C & 50°C.

Figure R
1336S-BP400

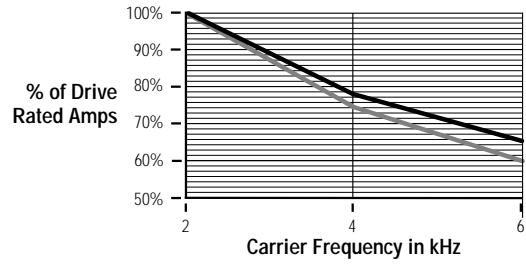


Figure S
1336S-BP450

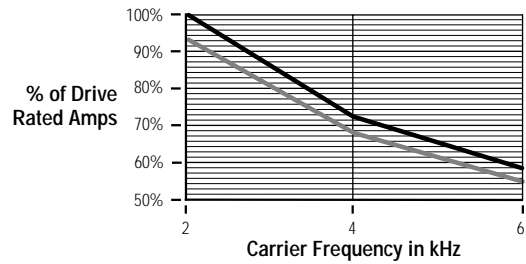


Figure T
1336S-B500 and B600

Assumes two (2) 725 CFM cooling fans for IP 20 (NEMA Type 1) enclosure

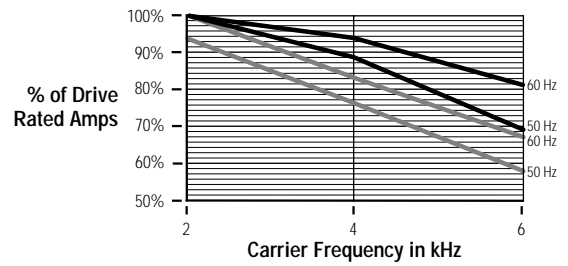


Figure U
1336S-CW10 through CW50

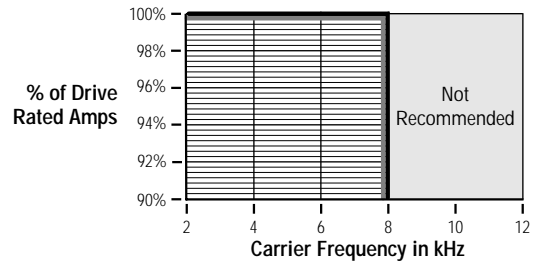


Figure V
1336S-C150

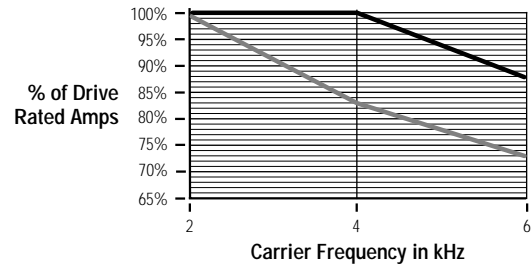


Figure W
1336S-C200

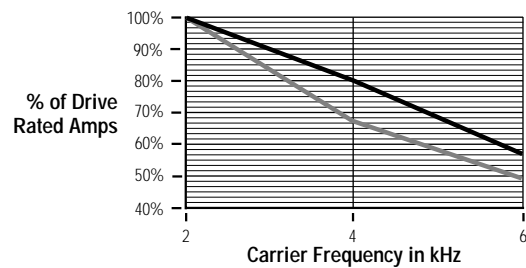


Figure X
1336S-C250

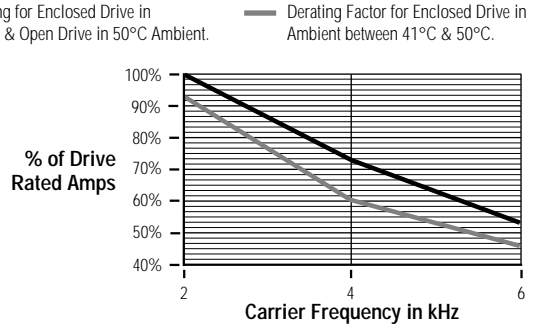


Figure Y
1336S-CX300

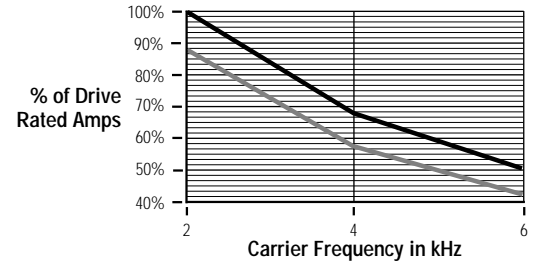


Figure Z
1336S-C300 through C600
Enclosed Drive in 40° C Ambient

Assumes two (2) 725 CFM cooling fans for IP 20 (NEMA Type 1) enclosure

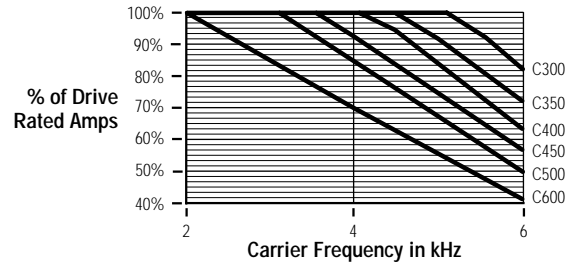
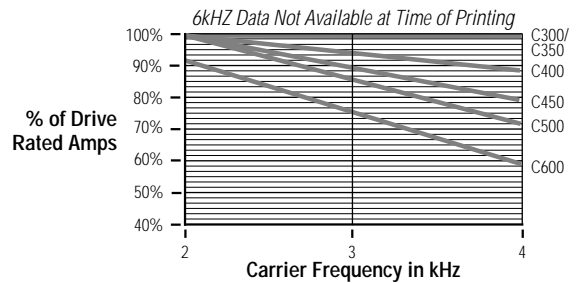


Figure AA
1336S-C300 through C600
Enclosed Drive in 41° - 50° C Ambient

Assumes two (2) 725 CFM cooling fans for IP 20 (NEMA Type 1) enclosure



ALTITUDE AND HIGH INPUT VOLTAGE

Figure BB
Altitude – All Drive Ratings

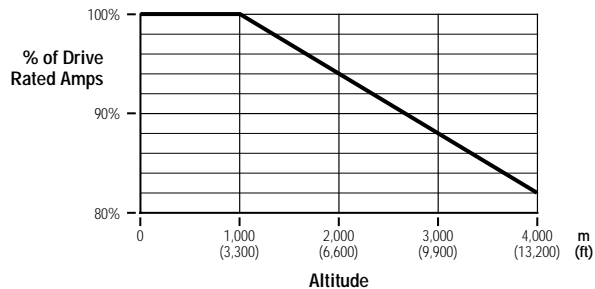
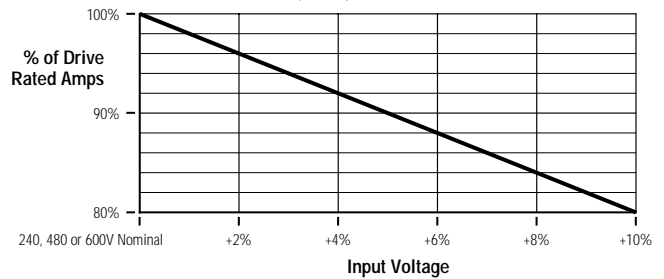


Figure CC
High Input Voltage – Required Only for the following drives:
1336S-x025 – 18.5 kW (25 HP) at 8 kHz
1336S-x030 – 22 kW (30 HP) at 6 or 8 kHz
1336S-x060 – 45 kW (60 HP) at 6 kHz



Parameter Cross Reference – By Number

No.	Name	Group	No.	Name	Group	No.	Name	Group
1	Output Voltage	Metering	78	Traverse Period	Feature Select	158	CR1 Out Select 4.01	I/O Config
2	% Output Curr	Metering	79	Max Traverse	Feature Select	159	Dig Out Freq	I/O Config
3	% Output Power	Metering	80	P Jump	Feature Select	160	Dig Out Current	I/O Config
4	Last Fault	Metering	81	Blwn Fuse Flt	Faults	161	Dig Out Torque	I/O Config
5	Freq Select 1	Setup + Frequency Set	82	Cur Lim Trip En	Faults	162	Torque Current	Metering
6	Freq Select 2	Frequency Set	83	Run Boost	Advanced Setup ②	163	Flux Current	Metering
7	Accel Time 1	Setup	84	Analog Invert	Advanced Setup	165	Speed KI	Encoder Feedback
8	Decel Time 1	Setup		Power OL Count 4.01	Metering	166	Speed Error	Encoder Feedback
9	DC Boost Select	Advanced Setup ②	85	Reset/Run Tries	Feature Select	167	Speed Integral	Encoder Feedback
	Control Select 4.01	Motor Control	86	Fault Buffer 0	Faults	168	Speed Adder	Encoder Feedback
10	Stop Select 1	Setup + Adv. Setup	87	Fault Buffer 1	Faults	169	Run/Accel Boost 2.01	Advanced Setup
11	Bus Limit En	Advanced Setup	88	Fault Buffer 2	Faults		Boost Slope 4.01	Motor Control
12	DC Hold Time	Advanced Setup	89	Fault Buffer 3	Faults	170	Rated Amps	Ratings ①
13	DC Hold Level	Advanced Setup	90	Analog Trim En	Advanced Setup	171	Rated kW	Ratings ①
14	Run On Power Up	Feature Select	91	Low Bus Fault	Faults	172	EEPROM Cksum 4.01	Diagnostics
15	Reset/Run Time	Feature Select	92	Logic Mask	Masks	173	Fault Alarms	Faults
16	Minimum Freq	Setup + Adv. Setup	93	Local Mask	Masks	174-176	CR2-4 Out Select 4.01	I/O Config
17	Base Frequency	Setup + Adv. Setup ②	94	Direction Mask	Masks	177	Motor NP RPM	Setup + Enc. Fdbk.
18	Base Voltage	Setup + Adv. Setup ②	95	Start Mask	Masks	178	Motor NP Hertz	Setup + Enc. Fdbk.
19	Maximum Freq	Setup + Adv. Setup ②	96	Jog Mask	Masks	179	Local Owner	Owners
20	Maximum Voltage	Setup + Adv. Setup ②	97	Reference Mask	Masks	180	Process 2 Par	Process Display
21	Input Mode	Setup + I/O Config 4.01	98	Accel Mask	Masks	181	Process 2 Scale	Process Display
22	MOP Increment	Frequency Set	99	Decel Mask	Masks	182-189	Process 2 Txt 1-8	Process Display
23	Output Power	Metering	100	Fault Mask	Masks	190	Motor NP Volts 4.01	Setup
24	Jog Frequency	Frequency Set	101	MOP Mask	Masks	191	Motor NP Amps 4.01	Setup
25	Analog Out Sel	I/O Config	102	Stop Owner	Owners	192	KI Amps 2.03	Advanced Setup ②
26	Stop Mode Used	Diagnostics	103	Direction Owner	Owners		Flux Amps Ref 4.01	Motor Control
27	Preset Freq 1	Frequency Set	104	Start Owner	Owners	193	KP Amps 2.03	Advanced Setup
28	Preset Freq 2	Frequency Set	105	Jog Owner	Owners	194	KI Volts	Linear List
29	Preset Freq 3	Frequency Set	106	Reference Owner	Owners		IR Drop Volts 4.01	Motor Control
30	Accel Time 2	Advanced Setup	107	Accel Owner	Owners	195	Slip Comp Gain 4.01	Feature Select
31	Decel Time 2	Advanced Setup	108	Decel Owner	Owners	196	KP Volts	Linear List
32	Skip Freq 1	Frequency Set	109	Fault Owner	Owners	198	Rated VT Amps	Ratings ①
33	Skip Freq 2	Frequency Set	110	MOP Owner	Owners	199	Rated VT kW	Ratings ①
34	Skip Freq 3	Frequency Set	111	Data In A1	Adapter I/O	200	Flux Up Time 4.01	Motor Control
35	Skip Freq Band	Frequency Set	112	Data In A2	Adapter I/O	201	Motor OL Fault 4.01	Faults
36	Current Limit	Setup	113	Data In B1	Adapter I/O	202	Motor OL Count 4.01	Metering
37	Overload Mode	Setup	114	Data In B2	Adapter I/O	203	VT Scaling	Setup
38	Overload Amps	Setup	115	Data In C1	Adapter I/O	204	Ground Warning 2.01	Faults
39	Flt Clear Mode	Faults	116	Data In C2	Adapter I/O	205	Latched Alarms 2.01	Diagnostics
40	Line Loss Fault	Faults	117	Data In D1	Adapter I/O	206	Alarm Mask 2.01	Masks
41	Motor Type	Advanced Setup	118	Data In D2	Adapter I/O	207	Fault Data 4.01	Faults
42	Slip @ F.L.A.	Feature Select	119	Data Out A1	Adapter I/O	208	Time Data 1	Linear List
43	Dwell Frequency	Feature Select	120	Data Out A2	Adapter I/O	209	Time Data 3	Linear List
44	Dwell Time	Feature Select	121	Data Out B1	Adapter I/O	210	Time Data 5	Linear List
45	PWM Frequency	Advanced Setup	122	Data Out B2	Adapter I/O	211	Time Data 7	Linear List
46	Pulse/Enc Scale	Freq. Set + Enc. Fdbk.	123	Data Out C1	Adapter I/O	212	DC Bus Memory	Diagnostics 2.03
47	Language	Feature Select	124	Data Out C2	Adapter I/O	213	PI Config 3.01	Process PI
48	Start Boost	Advanced Setup ②	125	Data Out D1	Adapter I/O	214	PI Status 3.01	Process PI
49	Break Frequency	Advanced Setup ②	126	Data Out D2	Adapter I/O	215	PI Ref Select 3.01	Process PI
50	Break Voltage	Advanced Setup ②	127	Process 1 Par	Process Display	216	PI Fdbk Select 3.01	Process PI
51	Clear Fault	Faults	128	Process 1 Scale	Process Display	217	PI Reference 3.01	Process PI
52	Stop Select 2	Advanced Setup	129-136	Process 1 Txt 1-8	Process Display	218	PI Feedback 3.01	Process PI
53	DC Bus Voltage	Metering	137	MOP Hertz	Metering	219	PI Error 3.01	Process PI
54	Output Current	Metering	138	Pot Hertz	Metering	220	PI Output 3.01	Process PI
55	Input Status	Diagnostics	139	0-10 Volt Hertz	Metering	221	KI Process 3.01	Process PI
56	S Curve Time	Feature Select	140	4-20 mA Hertz	Metering	222	KP Process 3.01	Process PI
57	S Curve Enable	Feature Select	141	Motor Mode	Diagnostics	223	PI Neg Limit 3.01	Process PI
59	Drive Status	Diagnostics	142	Power Mode	Diagnostics	224	PI Pos Limit 3.01	Process PI
60	Drive Alarm	Diagnostics	143	Flt Motor Mode	Faults	225	PI Preload 4.01	Process PI
61	Drive Type	Ratings ①	144	Flt Power Mode	Faults	226	Shear Pin Fault 4.01	Faults
62	Freq Source	Diagnostics	145	Fault Frequency	Faults	227	Adaptive I Lim 4.01	Setup
63	Pulse/Enc Hertz	Meter. + Enc. Fdbk. 2.01	146	Flt Driv Status	Faults	228	LLoss FStart 4.01	Feature Select
64	Set Defaults	Diagnostics	147	Drive Rtd Volts	Ratings ①	229	Freq Ref SqRoot 4.01	Frequency Set
65	Freq Command	Metering + Diagnostics	148	Rated CT Amps	Ratings ①	230	Save MOP Ref 4.01	Frequency Set
66	Output Freq	Metering	149	Rated CT kW	Ratings ①	231	Hold Level Sel 4.01	Advanced Setup
67	Output Pulses	Diagnostics	150	4-20 mA Loss Sel	Advanced Setup	232	Current Lmt Sel 4.01	Setup
69	Drive Direction	Diagnostics	151	Maximum Speed	Encoder Feedback	233	Abs Analog Out 4.01	I/O Config
70	Heatsink Temp	Metering + Diagnostics	152	Encoder Type	Encoder Feedback	234	Set Anlg Out Lo 4.01	I/O Config
71	Firmware Ver.	Ratings ①	153	Motor Poles	Encoder Feedback	235	Set Anlg Out Hi 4.01	I/O Config
72	Current Angle	Diagnostics	154	Anlg Out Offset	I/O Config	236	2nd Drive Sts 4.01	Diagnostics
73	Preset Freq 4	Frequency Set	155	Flying Start En	Feature Select	237	Set 0-10 Vlt Lo 4.01	Frequency Set
74	Preset Freq 5	Frequency Set	156	FStart Forward	Feature Select	238	Set 0-10 Vlt Hi 4.01	Frequency Set
75	Preset Freq 6	Frequency Set	157	FStart Reverse	Feature Select	239	Set 4-20 mA Lo 4.01	Frequency Set
76	Preset Freq 7	Frequency Set	158	Digital Out Sel	I/O Config	240	Set 4-20 mA Hi 4.01	Frequency Set
77	Speed Control	Enc. Fdbk. + Process PI						

X.xx Firmware version X.xx or later. ① Located in the "Diagnostics" group for firmware versions before 2.01. ② "Motor Control" group for firmware versions 4.01 & later.

Parameter Cross Reference – By Name

Name	No.	Group	Name	No.	Group	Name	No.	Group
2nd Drive Sts ^{4.01}	236	Diagnostics	Fault Buffer 3	89	Faults	PI Neg Limit ^{3.01}	223	Process PI
% Output Curr	2	Metering	Fault Data	207	Faults ^{4.01}	PI Output ^{3.01}	220	Process PI
% Output Power	3	Metering	Fault Frequency	145	Faults	PI Pos Limit ^{3.01}	224	Process PI
0-10 Volt Hertz	139	Metering	Fault Mask	100	Masks	PI Preload ^{4.01}	225	Process PI
4-20 mA Loss Sel	150	Advanced Setup	Fault Owner	109	Owners	PI Ref Select ^{3.01}	215	Process PI
4-20 mA Hertz	140	Metering	Firmware Ver.	71	Ratings ^①	PI Reference ^{3.01}	217	Process PI
Abs Analog Out ^{4.01}	233	I/O Config	Flt Clear Mode	39	Faults	PI Status ^{3.01}	214	Process PI
Accel Mask	98	Masks	Flt Driv Status	146	Faults	Pot Hertz	138	Metering
Accel Owner	107	Owners	Flt Motor Mode	143	Faults	Power Mode	142	Diagnostics
Accel Time 1	7	Setup	Flt Power Mode	144	Faults	Power OL Count ^{4.01}	84	Metering
Accel Time 2	30	Advanced Setup	Flux Amps Ref ^{4.01}	192	Motor Control	Preset Freq 1	27	Frequency Set
Adaptive I Lim ^{4.01}	227	Setup	Flux Current	163	Metering	Preset Freq 2	28	Frequency Set
Alarm Mask ^{2.01}	206	Masks	Flux Up Time ^{4.01}	200	Motor Control	Preset Freq 3	29	Frequency Set
Analog Invert	84	Advanced Setup	Flying Start En	155	Feature Select	Preset Freq 4	73	Frequency Set
Analog Out Sel	25	I/O Config	Freq Command	65	Metering + Diagnostics	Preset Freq 5	74	Frequency Set
Analog Trim En	90	Advanced Setup	Freq Ref SqRoot ^{4.01}	229	Frequency Set	Preset Freq 6	75	Frequency Set
Anlg Out Offset	154	I/O Config	Freq Select 1	5	Setup + Freq. Set	Preset Freq 7	76	Frequency Set
Base Frequency	17	Setup ^② + Adv. Setup	Freq Select 2	6	Frequency Set	Process 1 Par	127	Process Display
Base Voltage	18	Setup ^② + Adv. Setup	Freq Source	62	Diagnostics	Process 1 Scale	128	Process Display
Blwn Fuse Flt	81	Faults	FStart Forward	156	Feature Select	Process 1 Txt 1-8	129-136	Process Display
Boost Slope ^{4.01}	169	Motor Control	FStart Reverse	157	Feature Select	Process 2 Par	180	Process Display
Break Frequency	49	Advanced Setup ^②	Ground Warning ^{2.01}	204	Faults	Process 2 Scale	181	Process Display
Break Voltage	50	Advanced Setup ^②	Heatsink Temp	70	Metering + Diagnostics	Process 2 Txt 1-8	182-189	Process Display
Bus Limit En	11	Advanced Setup	Hold Level Sel ^{4.01}	231	Advanced Setup	Pulse/Enc Hertz	63	Meter. + Enc. Fdbk. ^{2.01}
Clear Fault	51	Faults	Input Mode	21	Setup + I/O Config ^{4.01}	Pulse/Enc Scale	46	Freq. Set + Enc. Fdbk.
Control Select ^{4.01}	9	Motor Control	Input Status	55	Diagnostics	PWM Frequency	45	Advanced Setup
CR1 Out Select ^{4.01}	158	I/O Config	IR Drop Volts ^{4.01}	194	Motor Control	Rated Amps	170	Ratings ^①
CR2-4 Out Select ^{4.01}	174-176	I/O Config	Jog Frequency	24	Frequency Set	Rated CT Amps	148	Ratings ^①
Cur Lim Trip En	82	Faults	Jog Mask	96	Masks	Rated CT kW	149	Ratings ^①
Current Angle	72	Diagnostics	Jog Owner	105	Owners	Rated kW	171	Ratings ^①
Current Limit	36	Setup	KI Amps ^{2.03}	192	Advanced Setup ^②	Rated VT Amps	198	Ratings ^①
Current Lmt Sel ^{4.01}	232	Setup	KP Amps ^{2.03}	193	Advanced Setup	Rated VT kW	199	Ratings ^①
Data In A1	111	Adapter I/O	KI Process ^{3.01}	221	Process PI	Reference Mask	97	Masks
Data In A2	112	Adapter I/O	KP Process ^{3.01}	222	Process PI	Reference Owner	106	Owners
Data In B1	113	Adapter I/O	KI Volts	194	Linear List	Reset/Run Time	15	Feature Select
Data In B2	114	Adapter I/O	KP Volts	196	Linear List	Reset/Run Tries	85	Feature Select
Data In C1	115	Adapter I/O	Language	47	Feature Select	Run/Accel Boost ^{2.01}	169	Advanced Setup
Data In C2	116	Adapter I/O	Last Fault	4	Metering	Run Boost	83	Advanced Setup ^②
Data In D1	117	Adapter I/O	Latched Alarms ^{2.01}	205	Diagnostics	Run On Power Up	14	Feature Select
Data In D2	118	Adapter I/O	Line Loss Fault	40	Faults	S Curve Enable	57	Feature Select
Data Out A1	119	Adapter I/O	LLoss FStart	228	Feature Select	S Curve Time	56	Feature Select
Data Out A2	120	Adapter I/O	Local Mask	98	Masks	Save MOP Ref ^{4.01}	230	Frequency Set
Data Out B1	121	Adapter I/O	Local Owner	179	Owners	Set 0-10 Vlt Hi ^{4.01}	238	I/O Config
Data Out B2	122	Adapter I/O	Logic Mask	92	Masks	Set 0-10 Vlt Lo ^{4.01}	237	I/O Config
Data Out C1	123	Adapter I/O	Low Bus Fault	91	Faults	Set 4-20 mA Hi ^{4.01}	240	I/O Config
Data Out C2	124	Adapter I/O	Max Traverse	79	Feature Select	Set 4-20 mA Lo ^{4.01}	239	I/O Config
Data Out D1	125	Adapter I/O	Maximum Freq	19	Setup + Adv. Setup	Set Anlg Out Hi ^{4.01}	235	I/O Config
Data Out D2	126	Adapter I/O	Maximum Speed	151	Encoder Feedback	Set Anlg Out Lo ^{4.01}	234	I/O Config
DC Boost Select	9	Advanced Setup ^②	Maximum Voltage	20	Setup ^② + Adv. Setup	Set Defaults	64	Diagnostics
DC Bus Memory	212	Diagnostics ^{2.03}	Minimum Freq	16	Setup + Adv. Setup	Shear Pin Fault ^{4.01}	226	Faults
DC Bus Voltage	53	Metering	MOP Hertz	137	Metering	Skip Freq 1	32	Frequency Set
DC Hold Level	13	Advanced Setup	MOP Increment	22	Frequency Set	Skip Freq 2	33	Frequency Set
DC Hold Time	12	Advanced Setup	MOP Mask	101	Masks	Skip Freq 3	34	Frequency Set
Decel Mask	99	Masks	MOP Owner	110	Owners	Skip Freq Band	35	Frequency Set
Decel Owner	108	Owners	Motor Mode	141	Diagnostics	Slip @ F.L.A.	42	Feature Select
Decel Time 1	8	Setup	Motor NP Amps ^{4.01}	191	Setup	Slip Comp Gain ^{4.01}	195	Feature Select
Decel Time 2	31	Advanced Setup	Motor NP Hertz	178	Enc. Fdbk. + Setup ^{4.01}	Speed Adder	168	Encoder Feedback
Dig Out Current	160	I/O Config	Motor NP RPM	177	Enc. Fdbk. + Setup ^{4.01}	Speed Control	77	Enc. Fdbk. + Process PI
Dig Out Freq	159	I/O Config	Motor NP Volts ^{4.01}	190	Setup	Speed Error	166	Encoder Feedback
Dig Out Torque	161	I/O Config	Motor OL Count ^{4.01}	202	Metering	Speed Integral	167	Encoder Feedback
Digital Out Sel	158	I/O Config	Motor OL Fault ^{4.01}	201	Faults	Speed KI	165	Encoder Feedback
Direction Mask	94	Masks	Motor Poles	153	Encoder Feedback	Start Boost	48	Advanced Setup ^②
Direction Owner	103	Owners	Motor Type	41	Advanced Setup	Start Mask	95	Masks
Drive Alarm	60	Diagnostics	Output Current	54	Metering	Start Owner	104	Owners
Drive Direction	69	Diagnostics	Output Freq	66	Metering	Stop Mode Used	26	Diagnostics
Drive Rtd Volts	147	Ratings ^①	Output Power	23	Metering	Stop Owner	102	Owners
Drive Status	59	Diagnostics	Output Pulses	67	Diagnostics	Stop Select 1	10	Setup + Adv. Setup
Drive Type	61	Ratings ^①	Output Voltage	1	Metering	Stop Select 2	52	Advanced Setup
Dwell Frequency	43	Feature Select	Overload Amps	38	Setup	Time Data 1	208	Linear List
Dwell Time	44	Feature Select	Overload Mode	37	Setup	Time Data 3	209	Linear List
EEPROM Cksum ^{4.01}	172	Diagnostics	P Jump	80	Feature Select	Time Data 5	210	Linear List
Encoder Type	152	Encoder Feedback	PI Config ^{3.01}	213	Process PI	Time Data 7	211	Linear List
Fault Alarms	173	Faults	PI Error ^{3.01}	219	Process PI	Torque Current	162	Metering
Fault Buffer 0	86	Faults	PI Fdbk Select ^{3.01}	216	Process PI	Traverse Period	78	Feature Select
Fault Buffer 1	87	Faults	PI Feedback ^{3.01}	218	Process PI	VT Scaling	203	Setup
Fault Buffer 2	88	Faults						

X.xx Firmware version X.xx or later. ^① Located in the "Diagnostics" group for firmware versions before 2.01. ^② "Motor Control" group for firmware versions 4.01 & later.

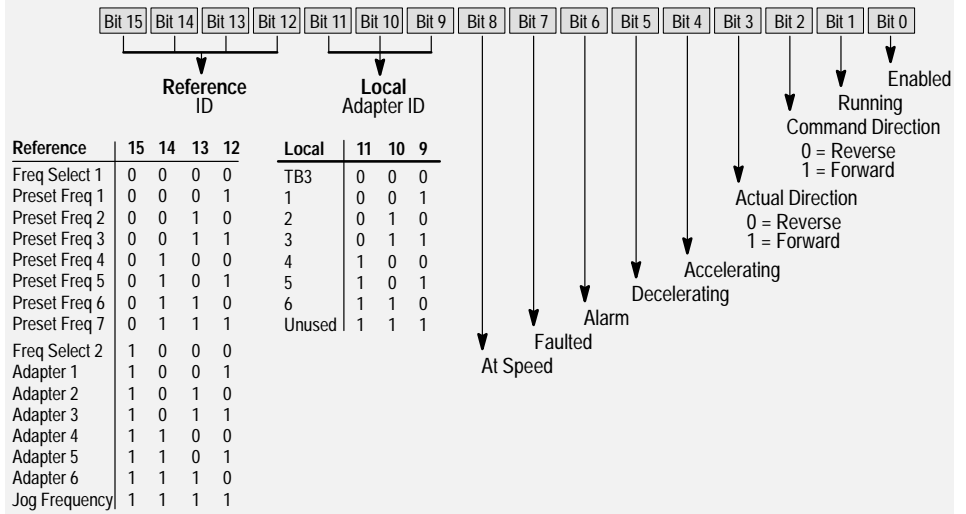
HIM Character Map

Character	Decimal	Hex	Character	Decimal	Hex	Character	Decimal	Hex
!	032	20	b	096	60	P	193	C1
"	033	21	a	097	61	Q	194	C2
#	034	22	b	098	62	R	195	C3
\$	035	23	c	099	63	S	196	C4
%	036	24	d	100	64	T	197	C5
&	037	25	e	101	65	U	198	C6
'	038	26	f	102	66	V	199	C7
(039	27	g	103	67	W	200	C8
)	040	28	h	104	68	X	201	C9
*	041	29	i	105	69	Y	202	CA
+	042	2A	j	106	6A	Z	203	CB
,	043	2B	k	107	6B	[204	CC
-	044	2C	l	108	6C	\	205	CD
.	045	2D	m	109	6D]	206	CE
/	046	2E	n	110	6E	^	207	CF
0	047	2F	o	111	6F	R	208	D0
1	048	30	p	112	70	S	209	D1
2	049	31	q	113	71	T	210	D2
3	050	32	r	114	72	U	211	D3
4	051	33	s	115	73	V	212	D4
5	052	34	t	116	74	W	213	D5
6	053	35	u	117	75	X	214	D6
7	054	36	v	118	76	Y	215	D7
8	055	37	w	119	77	Z	216	D8
9	056	38	x	120	78	[217	D9
:	057	39	y	121	79	\	218	DA
;	058	3A	z	122	7A]	219	DB
<	059	3B	{	123	7B	^	220	DC
=	060	3C		124	7C	Q	221	DD
>	061	3D	}	125	7D	P	222	DE
?	062	3E	c	126	7E	O	223	DF
@	063	3F	d	127	7F	_	224	E0
A	064	40	o	161	A1	`	225	E1
B	065	41	1	162	A2	b	226	E2
C	066	42	2	163	A3	c	227	E3
D	067	43	3	164	A4	d	228	E4
E	068	44	4	165	A5	e	229	E5
F	069	45	5	166	A6	f	230	E6
G	070	46	6	167	A7	g	231	E7
H	071	47	7	168	A8	h	232	E8
I	072	48	8	169	A9	i	233	E9
J	073	49	9	170	AA	j	234	EA
K	074	4A	:	171	AB	a	235	EB
L	075	4B	;	172	AC	l	236	EC
M	076	4C	<	173	AD	m	237	ED
N	077	4D	=	174	AE	n	238	EE
O	078	4E	>	175	AF	o	239	EF
P	079	4F	?	176	B0	p	240	F0
Q	080	50	@	177	B1	q	241	F1
R	081	51	A	178	B2	r	242	F2
S	082	52	B	179	B3	s	243	F3
T	083	53	C	180	B4	t	244	F4
U	084	54	D	181	B5	u	245	F5
V	085	55	E	182	B6	v	246	F6
W	086	56	F	183	B7	w	247	F7
X	087	57	G	184	B8	x	248	F8
Y	088	58	H	185	B9	y	249	F9
Z	089	59	I	186	BA	z	250	FA
[090	5A	J	187	BB	{	251	FB
a	091	5B	K	188	BC		252	FC
]	092	5C	L	189	BD	}	253	FD
^	093	5D	M	190	BE		255	FF
_	094	5E	N	191	BF			
	095	5F	O	192	CO			

Communications Data Information Format

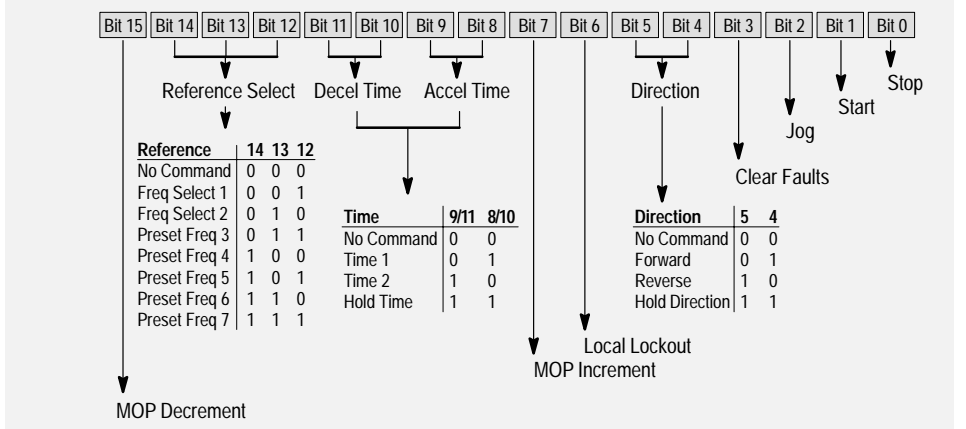
Drive Status Structure

This provides the drive status information that will be sent to the logic controllers input image table when the Communication Module is set to control the drive.



Logic Control Structure

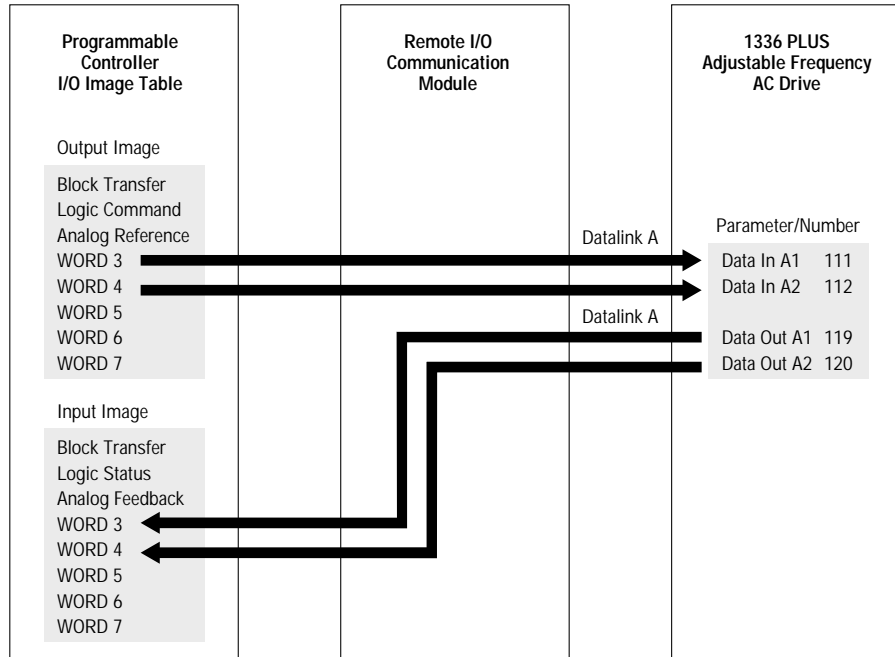
This information provides the control logic information that is sent to the drive through the logic controllers output image table when the Communication Module is set to control the drive.



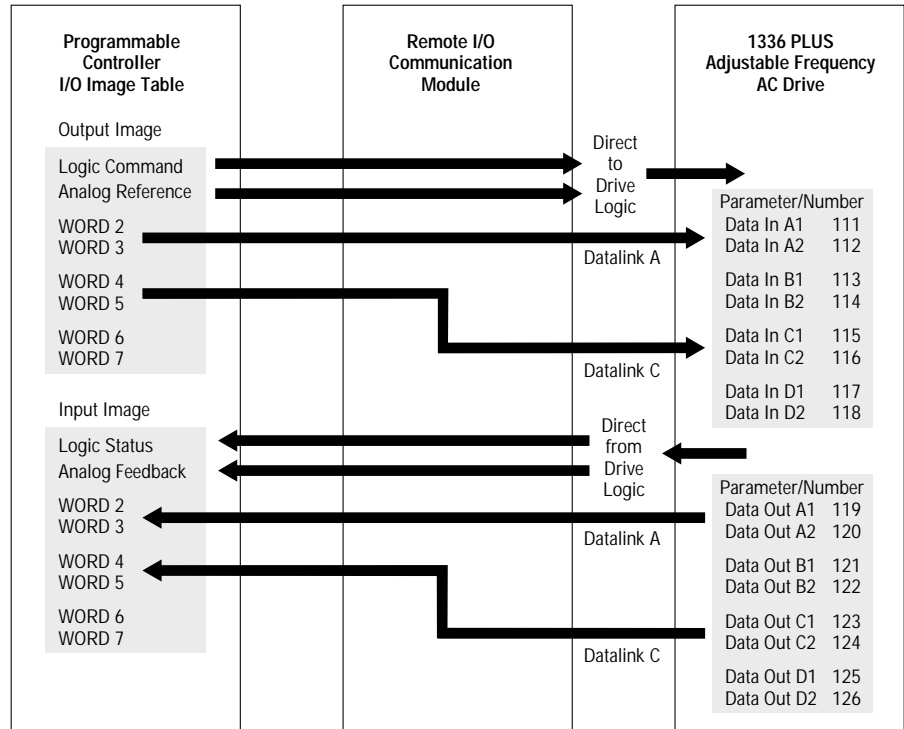
Typical Programmable Controller Communications Configurations

If block transfers are programmed to continuously write data to the drive, the EEPROM will quickly exceed its life cycle and malfunction. The 1336 PLUS does not use RAM to temporarily store parameter data, but rather stores the data immediately to the EEPROM. Since the EEPROM has a defined number of “write” cycles available, frequent block transfers should not be programmed.

Using Datalink A¹

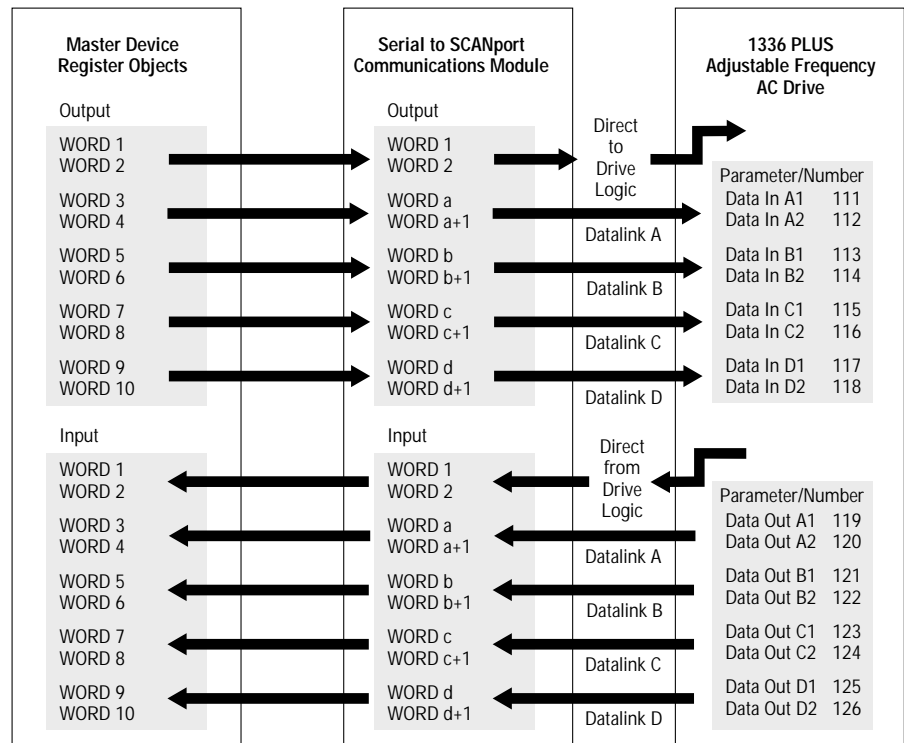


Without Block Transfer¹



¹ Refer to the 1203 User Manual for further information.

Typical Serial Communications Configurations



Read/Write Parameter Record

When using a Series B HIM, the parameters listed can be uploaded to the HIM for downloading to other drives.

No.	Name	Setting	No.	Name	Setting	No.	Name	Setting	No.	Name	Setting
5	Freq Select 1	_____	47	Language	_____	120	Data Out A2	_____	184	Process 2 Txt 3	_____
6	Freq Select 2	_____	48	Start Boost	_____	121	Data Out B1	_____	185	Process 2 Txt 4	_____
7	Accel Time 1	_____	49	Break Frequency	_____	122	Data Out B2	_____	186	Process 2 Txt 5	_____
8	Decel Time 1	_____	50	Break Voltage	_____	123	Data Out C1	_____	187	Process 2 Txt 6	_____
9	DC Boost Select	_____	52	Stop Select 2	_____	124	Data Out C2	_____	188	Process 2 Txt 7	_____
9	Control Select	_____	56	S Curve Time	_____	125	Data Out D1	_____	189	Process 2 Txt 8	_____
10	Stop Select 1	_____	57	S Curve Enable	_____	126	Data Out D2	_____	190	Motor NP Volts	_____
11	Bus Limit En	_____	73	Preset Freq 4	_____	127	Process 1 Par	_____	191	Motor NP Amps	_____
12	DC Hold Time	_____	74	Preset Freq 5	_____	128	Process 1 Scale	_____	192	KI Amps	_____
13	DC Hold Level	_____	75	Preset Freq 6	_____	129	Process 1 Txt 1	_____	192	Flux Amps Ref	_____
14	Run On Power Up	_____	76	Preset Freq 7	_____	130	Process 1 Txt 2	_____	193	KP Amps	_____
15	Reset/Run Time	_____	77	Speed Control	_____	131	Process 1 Txt 3	_____	194	IR Drop Volts	_____
16	Minimum Freq	_____	78	Traverse Period	_____	132	Process 1 Txt 4	_____	195	Slip Comp Gain	_____
17	Base Frequency	_____	79	Max Traverse	_____	133	Process 1 Txt 5	_____	200	Flux Up Time	_____
18	Base Voltage	_____	80	P Jump	_____	134	Process 1 Txt 6	_____	201	Motor OL Fault	_____
19	Maximum Freq	_____	81	Blwn Fuse Flt	_____	135	Process 1 Txt 7	_____	203	VT Scaling	_____
20	Maximum Voltage	_____	82	Cur Lim Trip En	_____	136	Process 1 Txt 8	_____	204	Ground Warning	_____
21	Input Mode	_____	83	Run Boost	_____	150	4-20 mA Loss Sel	_____	206	Alarm Mask	_____
22	MOP Increment	_____	84	Analog Invert	_____	151	Maximum Speed	_____	213	PI Config	_____
24	Jog Frequency	_____	85	Reset/Run Tries	_____	152	Encoder Type	_____	215	PI Ref Select	_____
25	Analog Out Sel	_____	90	Analog Trim En	_____	154	Anlg Out Offset	_____	216	PI Fdbk Select	_____
27	Preset Freq 1	_____	91	Low Bus Fault	_____	155	Flying Start En	_____	221	KI Process	_____
28	Preset Freq 2	_____	92	Logic Mask	_____	156	FStart Forward	_____	222	KP Process	_____
29	Preset Freq 3	_____	93	Local Mask	_____	157	FStart Reverse	_____	223	PI Neg Limit	_____
30	Accel Time 2	_____	94	Direction Mask	_____	158	Digital Out Sel	_____	224	PI Pos Limit	_____
31	Decel Time 2	_____	95	Start Mask	_____	158	CR1 Out Select	_____	225	PI Preload	_____
32	Skip Freq 1	_____	96	Jog Mask	_____	159	Dig Out Freq	_____	226	Shear Pin Fault	_____
33	Skip Freq 2	_____	97	Reference Mask	_____	160	Dig Out Current	_____	227	Adaptive I Lim	_____
34	Skip Freq 3	_____	98	Accel Mask	_____	161	Dig Out Torque	_____	228	LLoss FStart	_____
35	Skip Freq Band	_____	99	Decel Mask	_____	165	Speed KI	_____	229	Freq Ref SqRoot	_____
36	Current Limit	_____	100	Fault Mask	_____	169	Run/Accel Boost	_____	230	Save MOP Ref	_____
37	Overload Mode	_____	101	MOP Mask	_____	169	Boost Slope	_____	231	Hold Level Sel	_____
38	Overload Amps	_____	111	Data In A1	_____	174	CR2 Out Select	_____	232	Current Lmt Sel	_____
39	Flt Clear Mode	_____	112	Data In A2	_____	175	CR3 Out Select	_____	233	Abs Analog Out	_____
40	Line Loss Fault	_____	113	Data In B1	_____	176	CR4 Out Select	_____	234	Set Anlg Out Lo	_____
41	Motor Type	_____	114	Data In B2	_____	177	Motor NP RPM	_____	235	Set Anlg Out Hi	_____
42	Slip @ F.L.A.	_____	115	Data In C1	_____	178	Motor NP Hertz	_____	237	Set 0-10 Vlt Lo	_____
43	Dwell Frequency	_____	116	Data In C2	_____	180	Process 2 Par	_____	238	Set 0-10 Vlt Hi	_____
44	Dwell Time	_____	117	Data In D1	_____	181	Process 2 Scale	_____	239	Set 4-20 mA Lo	_____
45	PWM Frequency	_____	118	Data In D2	_____	182	Process 2 Txt 1	_____	240	Set 4-20 mA Hi	_____
46	Pulse/Enc Scale	_____	119	Data Out A1	_____	183	Process 2 Txt 2	_____			

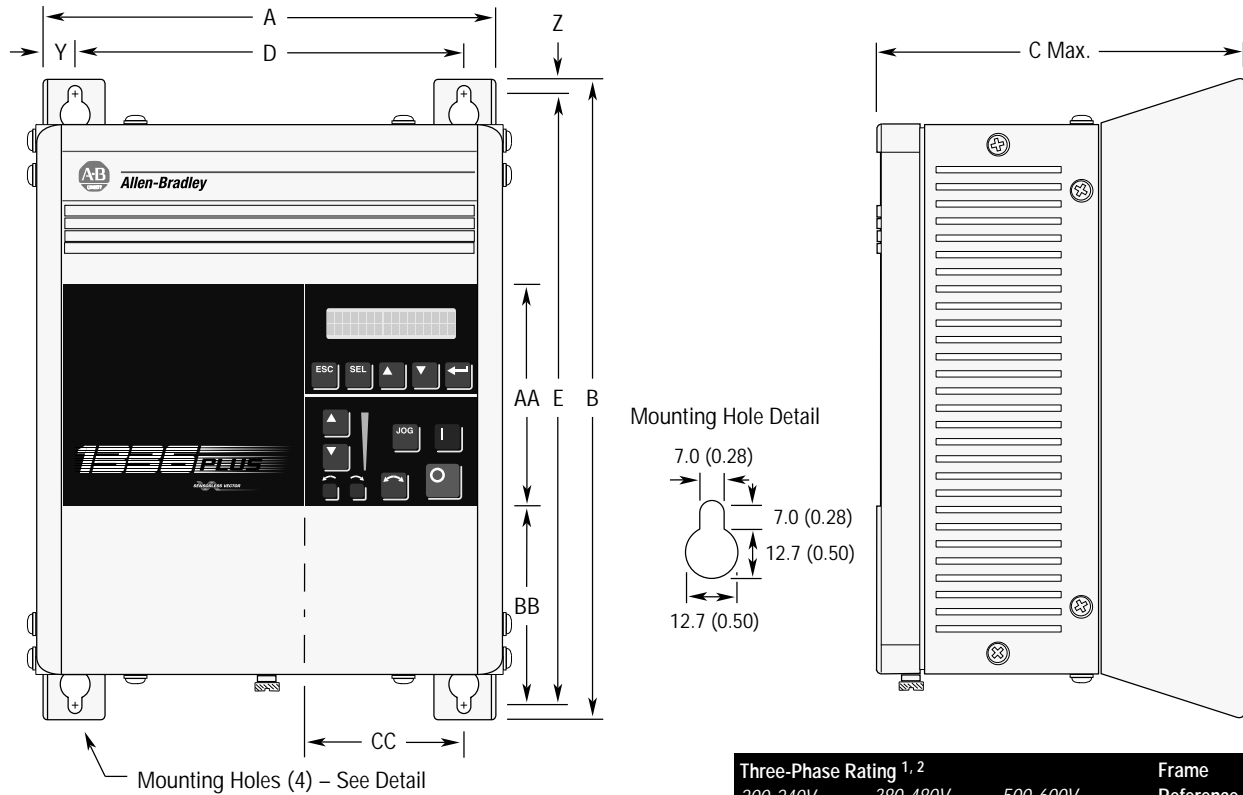
Dimensions

Appendix B provides detailed dimension information for the 1336 PLUS. Included are:

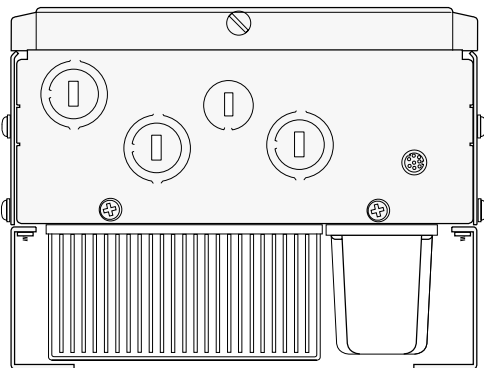
- IP 20 (NEMA Type 1) Dimensions.
- IP65/54 (NEMA Type 4/12) Dimensions.
- Heat Sink-through-the-Back Cutout Dimensions.
- TB1 Terminal Block Dimensions for D, E & G Frame Drives.
- Typical Mounting of a G Frame Open Chassis Drive in a User Supplied Enclosure.

Important: The dimensions given on the following drawings are for estimating purposes only. Contact your Allen-Bradley Sales Office if certified drawings are required.

IP 20 (NEMA Type 1) Dimensions – Frames A1 through A4



Bottom View Will Vary with HP – See Bottom View Dimensions



All Dimensions in Millimeters and (Inches)
All Weights in Kilograms and (Pounds)

Three-Phase Rating ^{1, 2}			Frame Reference
200-240V	380-480V	500-600V	
0.37-0.75 kW	0.37-1.2 kW	–	A1
0.5-1 HP	0.5-1.5 HP	–	A2
1.2-1.5 kW	1.5-2.2 kW	–	A3
1.5-2 HP	2-3 HP	–	A4
2.2-3.7 kW	3.7 kW	–	A4
3-5 HP	5 HP	–	A4
–	5.5-7.5 kW *	0.75-3.7 kW	A4
–	7.5-10 HP	1-5 HP	A4
5.5-11 kW	5.5-22 kW *	5.5-15 kW	B1/B2
7.5-15 HP	7.5-30 HP	7.5-20 HP	B1/B2
15-22 kW	30-45 kW	18.5-45 kW	C
20-30 HP	40-60 HP	25-60 HP	C
30-45 kW	45-112 kW	56-93 kW	D
40-60 HP	60-150 HP	75-125 HP	D
56-93 kW	112-187 kW	112-187 kW	E
75-125 HP	150-250 HP	150-250 HP	E
–	187-336 kW	187-336 kW	F
–	250-450 HP	250-450 HP	F
–	187-448 kW	224-448 kW	G
–	250-600 HP	300-600 HP	G

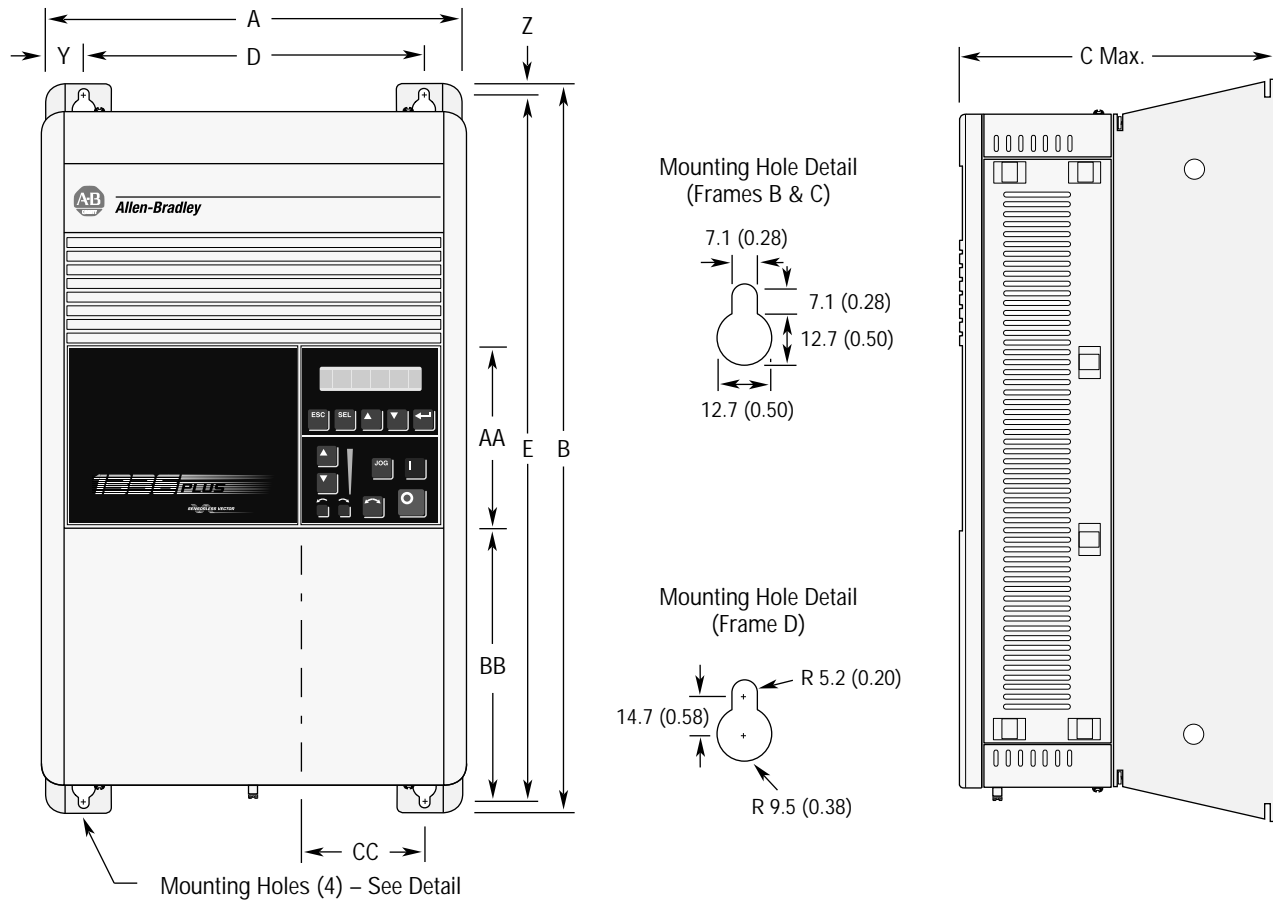
* Use care when choosing Frame Reference - Some ratings may exist in another frame size.

Frame Reference	A	B	C Max.	D	E	Y	Z	AA	BB	CC	Shipping Weights
A1	215.9 (8.50)	290.0 (11.42)	160.0 (6.30)	185.2 (7.29)	275.0 (10.83)	15.35 (0.60)	7.5 (0.30)	130.0 (5.12)	76.2 (3.00)	85.3 (3.36)	4.31 kg (9.5 lbs.)
A2	215.9 (8.50)	290.0 (11.42)	180.5 (7.10)	185.2 (7.29)	275.0 (10.83)	15.35 (0.60)	7.5 (0.30)	130.0 (5.12)	76.2 (3.00)	85.3 (3.36)	5.49 kg (12.1 lbs.)
A3	215.9 (8.50)	290.0 (11.42)	207.0 (8.15)	185.2 (7.29)	275.0 (10.83)	15.35 (0.60)	7.5 (0.30)	130.0 (5.12)	76.2 (3.00)	85.3 (3.36)	6.71 kg (14.8 lbs.)
A4	260.0 (10.24)	350.0 (13.78)	212.0 (8.35)	230.0 (9.06)	320.0 (12.60)	15.35 (0.60)	15.35 (0.60)	130.0 (5.12)	133.0 (5.23)	86.0 (3.39)	15.90 kg (35.0 lbs.)

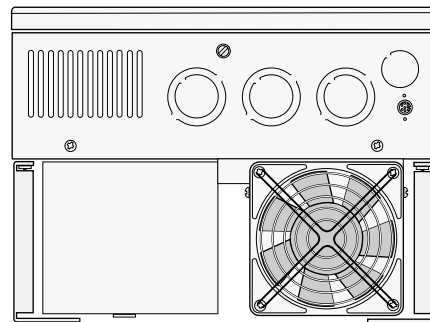
¹ Refer to Chapter 1 for catalog numbers and Appendix for derating info.

² kW/HP are constant torque (CT) ratings.

IP 20 (NEMA Type 1) Dimensions – Frames B, C, D



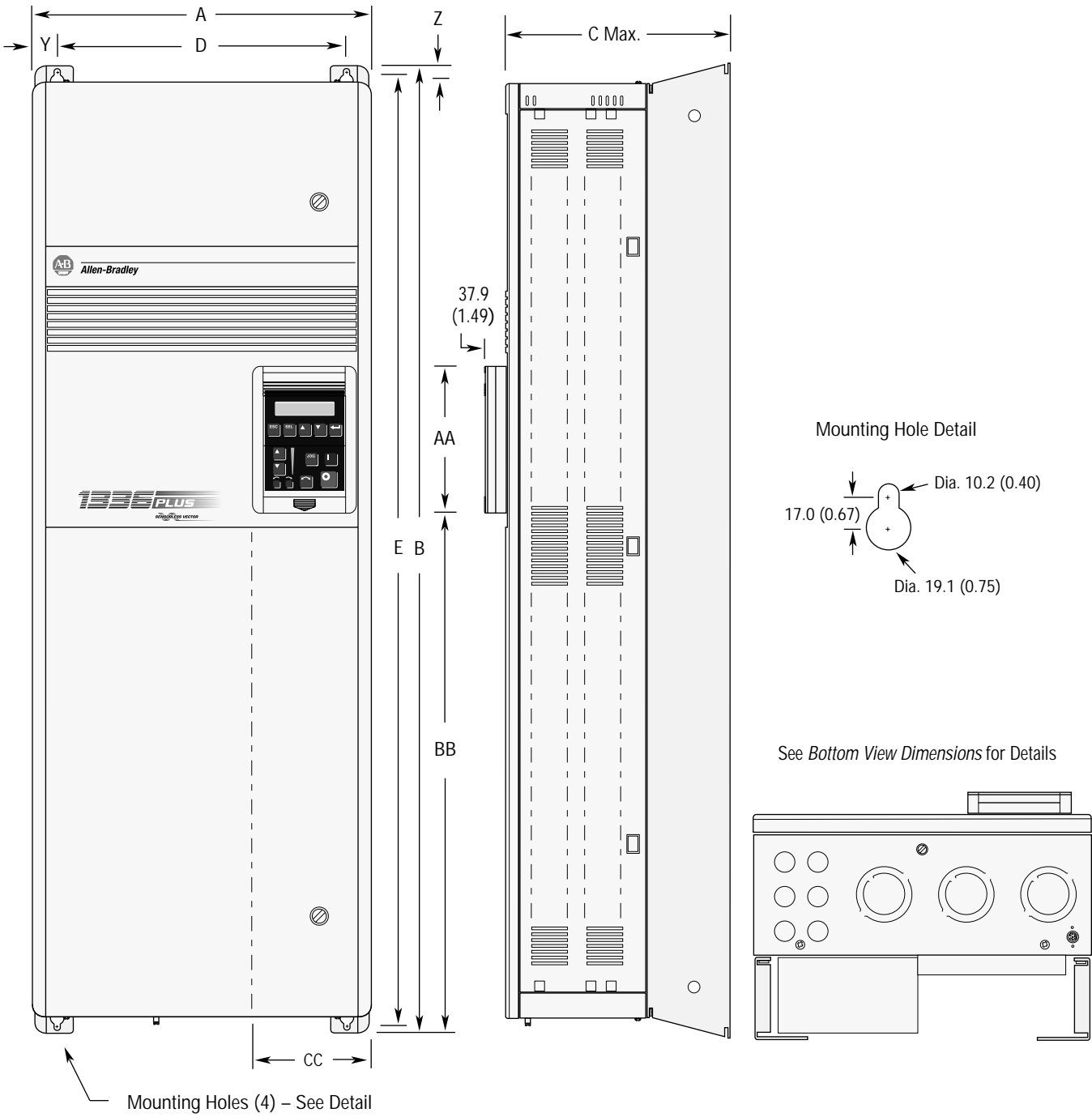
Bottom View Will Vary with HP – See *Bottom View Dimensions*



All Dimensions in Millimeters and (Inches)
 All Weights in Kilograms and (Pounds)

Frame Reference	A	B	C Max.	D	E	Y	Z	AA	BB	CC	Shipping Weight
B1/B2	276.4 (10.88)	476.3 (18.75)	225.0 (8.86)	212.6 (8.37)	461.0 (18.15)	32.00 (1.26)	7.6 (0.30)	131.1 (5.16)	180.8 (7.12)	71.9 (2.83)	22.7 kg (50 lbs.)
C	301.8 (11.88)	701.0 (27.60)	225.0 (8.86)	238.0 (9.37)	685.8 (27.00)	32.00 (1.26)	7.6 (0.30)	131.1 (5.16)	374.7 (14.75)	71.9 (2.83)	38.6 kg (85 lbs.)
D	381.5 (15.02)	1240.0 (48.82)	270.8 (10.66)	325.9 (12.83)	1216.2 (47.88)	27.94 (1.10)	11.94 (0.47)	131.1 (5.16)	688.6 (27.11)	83.6 (3.29)	108.9 kg (240 lbs.)

IP 20 (NEMA Type 1) & Open Dimensions - Frame E

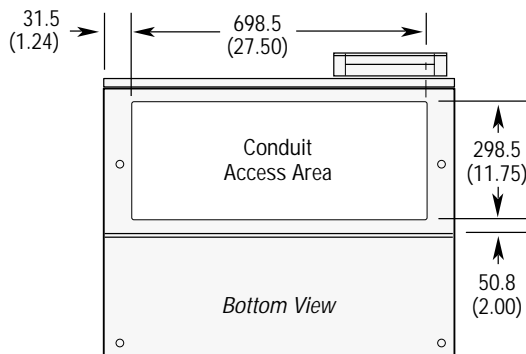
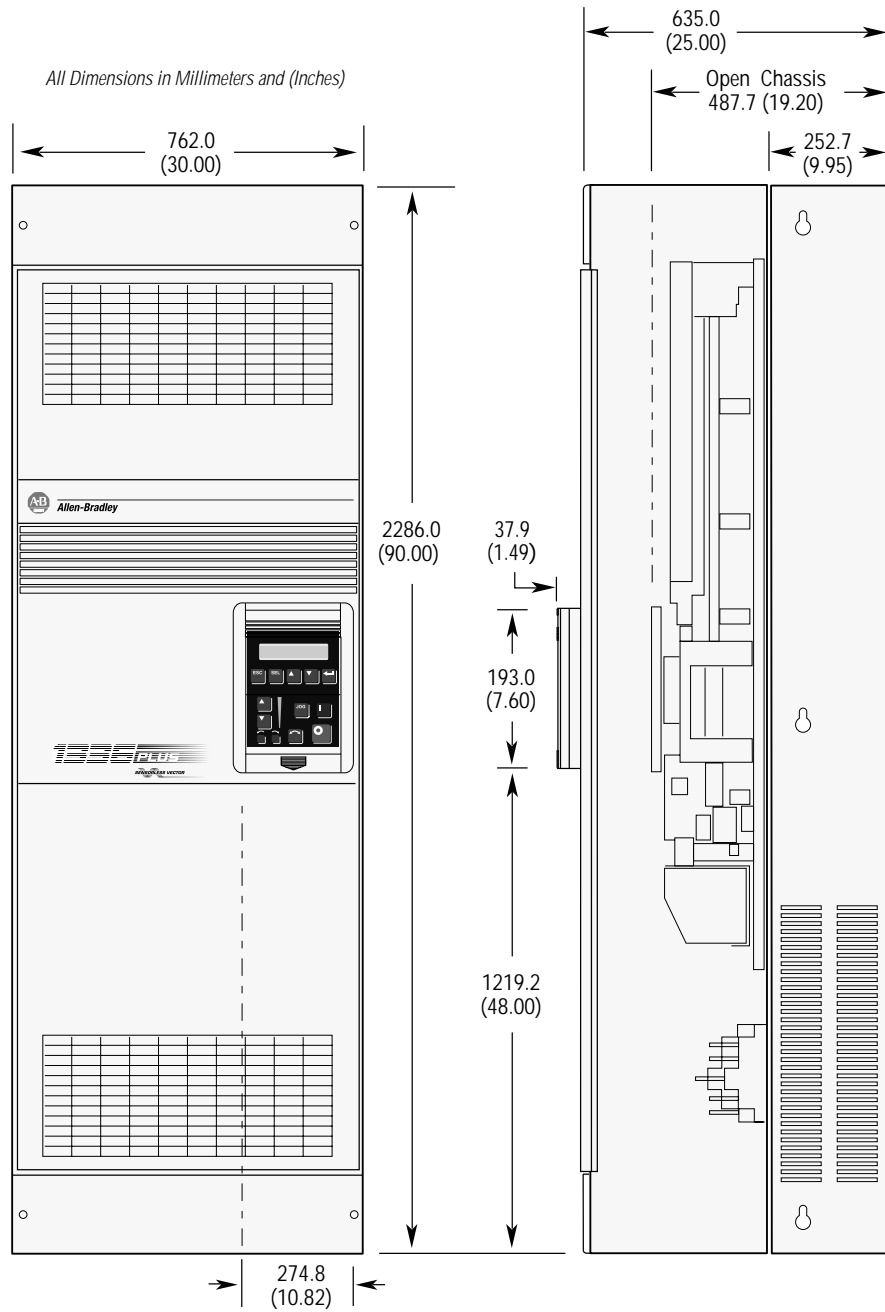


All Dimensions in Millimeters and (Inches)
 All Weights in Kilograms and (Pounds)

Frame Reference	A	B	C Max.	D	E	Y	Z	AA	BB	CC	Shipping Weight
E - Enclosed	511.0 (20.12)	1498.6 (59.00)	424.4 (16.71)	477.5 (18.80)	1447.8 (57.00)	16.8 (0.66)	40.1 (1.61)	195.0 (7.68)	901.4 (35.49)	151.9 (5.98)	186 kg (410 lbs.)
E - Open	511.0 (20.12)	1498.6 (59.00)	372.6 (14.67)	477.5 (18.80)	1447.8 (57.00)	16.8 (0.66)	40.1 (1.61)	138.4 (5.45)	680.0 (26.77)	126.3 (4.97)	163 kg (360 lbs.)

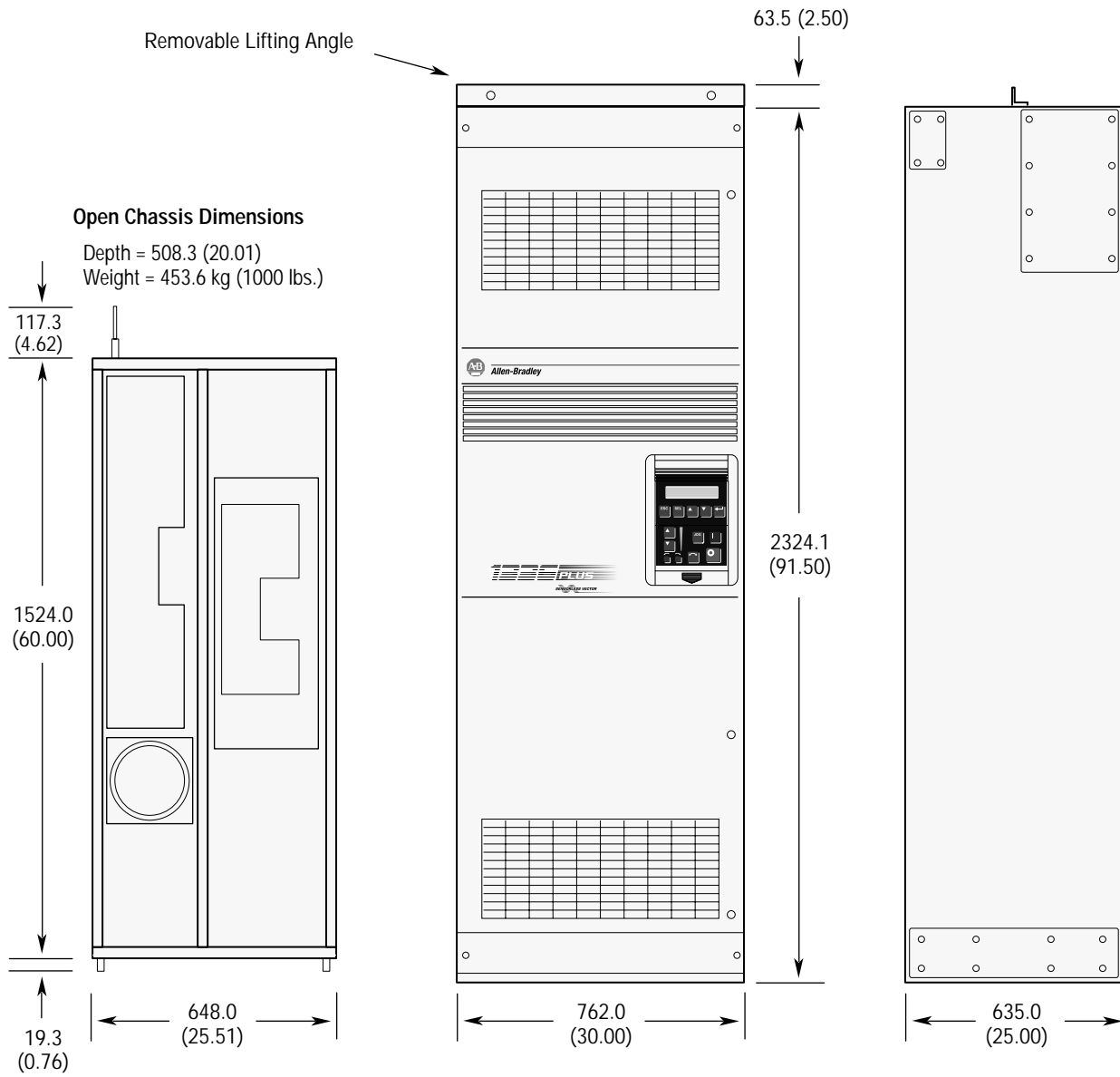
IP 20 (NEMA Type 1) & Open Dimensions - Frame F

All Dimensions in Millimeters and (Inches)

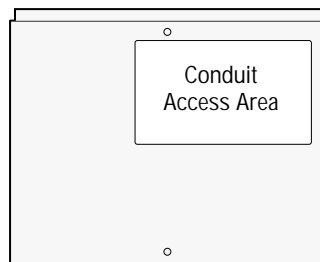


Approximate Shipping Weight (drive & pallet):
415.0 kg (915 lbs.)

IP 20 (NEMA Type 1) & Open Dimensions - Frame G



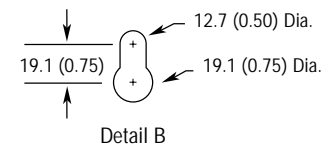
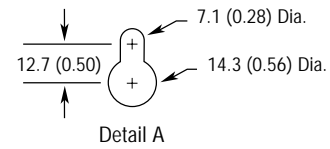
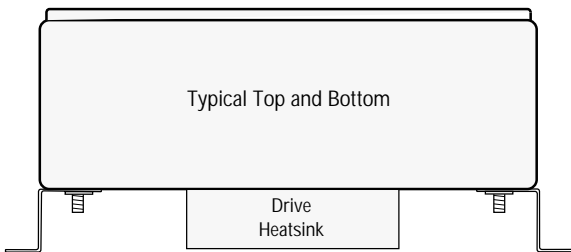
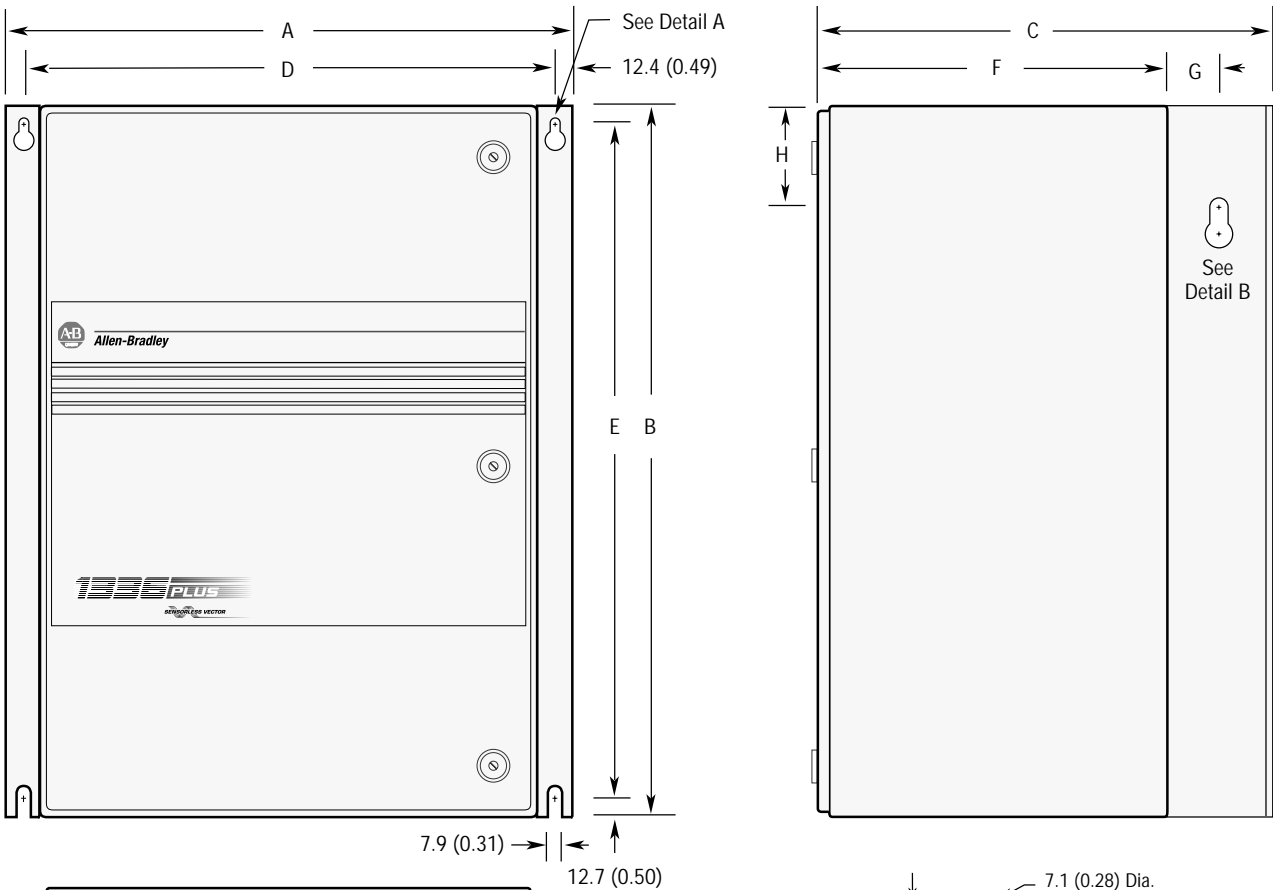
Important: Two (2) 725 CFM fans are required if an open type drive is mounted in a user supplied enclosure.



All Dimensions in Millimeters and (Inches)

See Bottom View Dimensions for Details

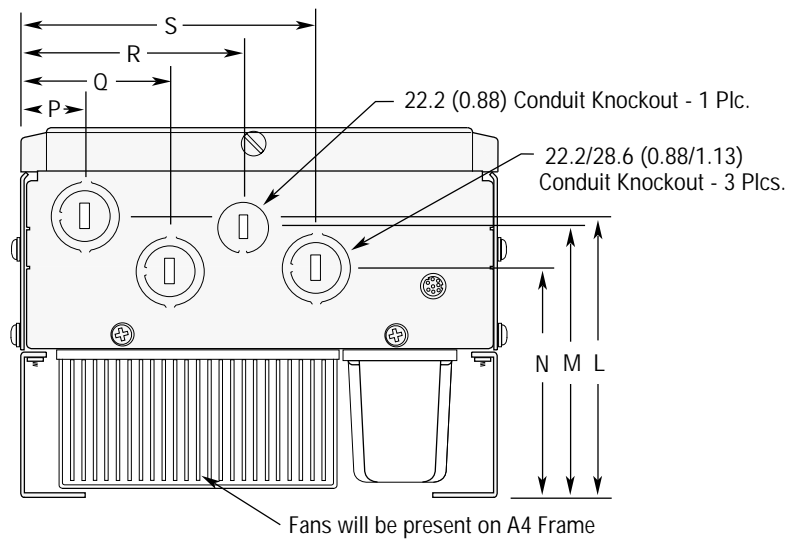
IP 65/54 (NEMA Type 4/12) Dimensions



All Dimensions in Millimeters and (Inches)

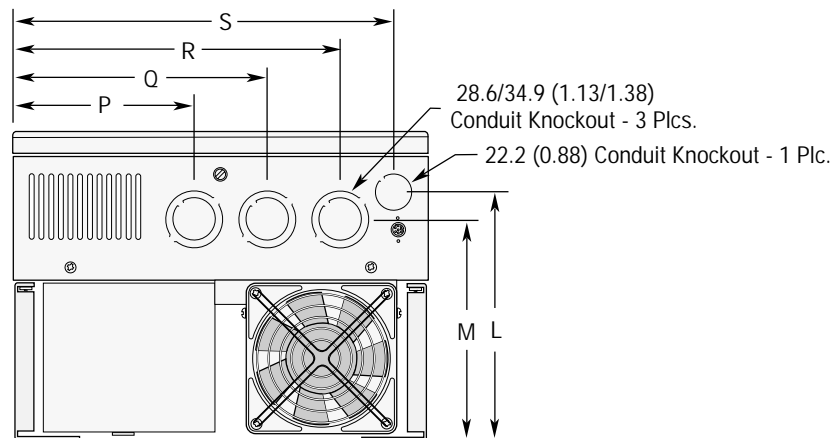
Frame Reference	A	B	C	D	E	F	G	H	Approx. Ship Weight
A1	430.0 (16.93)	525.0 (20.67)	350.0 (13.78)	404.9 (15.94)	500.1 (19.69)	250.0 (9.84)	N/A	N/A	16.8 kg (37.0 lbs.)
A2	430.0 (16.93)	525.0 (20.67)	350.0 (13.78)	404.9 (15.94)	500.1 (19.69)	250.0 (9.84)	N/A	N/A	17.9 kg (39.4 lbs.)
A3	430.0 (16.93)	525.0 (20.67)	350.0 (13.78)	404.9 (15.94)	500.1 (19.69)	250.0 (9.84)	N/A	N/A	18.6 kg (41.0 lbs.)
A4	655.0 (25.79)	650.0 (25.59)	425.0 (16.74)	629.9 (24.80)	625.1 (24.61)	293.0 (11.54)	63.5 (2.50)	76.2 (3.00)	39.5 kg (87.0 lbs.)
B1 5.5 kW (7.5 HP) at 200-240V AC 5.5-11 kW (7.5-15 HP) at 380-480V AC 5.5-7.5 kW (7.5-10 HP) at 500-600V AC	655.0 (25.79)	650.0 (25.59)	425.0 (16.74)	629.9 (24.80)	625.1 (24.61)	293.0 (11.54)	63.5 (2.50)	76.2 (3.00)	44.7 kg (98.5 lbs.)
B2 7.5-11 kW (10-15 HP) at 200-240V AC 15-22 kW (20-30 HP) at 380-480V AC 11-15 kW (15-20 HP) at 500-600V AC	655.0 (25.79)	900.0 (35.43)	425.0 (16.74)	629.9 (24.80)	875.0 (34.45)	293.0 (11.54)	63.5 (2.50)	76.2 (3.00)	56.5 kg (124.5 lbs.)
C	655.0 (25.79)	1200.0 (47.24)	425.0 (16.74)	629.9 (24.80)	1174.5 (46.22)	293.0 (11.54)	63.5 (2.50)	76.2 (3.00)	80.7 kg (178.0 lbs.)

IP 20 (NEMA Type 1) Bottom View Dimensions – Frames A through C
Frames A1 through A4



Frame Reference	L	M	N	P	Q	R	S
A1	111.8 (4.40)	105.4 (4.15)	86.3 (3.40)	31.0 (1.22)	69.1 (2.72)	102.1 (4.02)	135.4 (5.33)
A2	132.3 (5.21)	126.0 (4.96)	106.9 (4.21)	31.0 (1.22)	69.1 (2.72)	102.1 (4.02)	135.4 (5.33)
A3	158.8 (6.25)	152.4 (6.00)	133.4 (5.25)	31.0 (1.22)	69.1 (2.72)	102.1 (4.02)	135.4 (5.33)
A4	164.0 (6.45)	164.0 (6.45)	139.0 (5.47)	27.0 (1.06)	65.0 (2.56)	97.0 (3.82)	128.7 (5.07)

Frames B and C

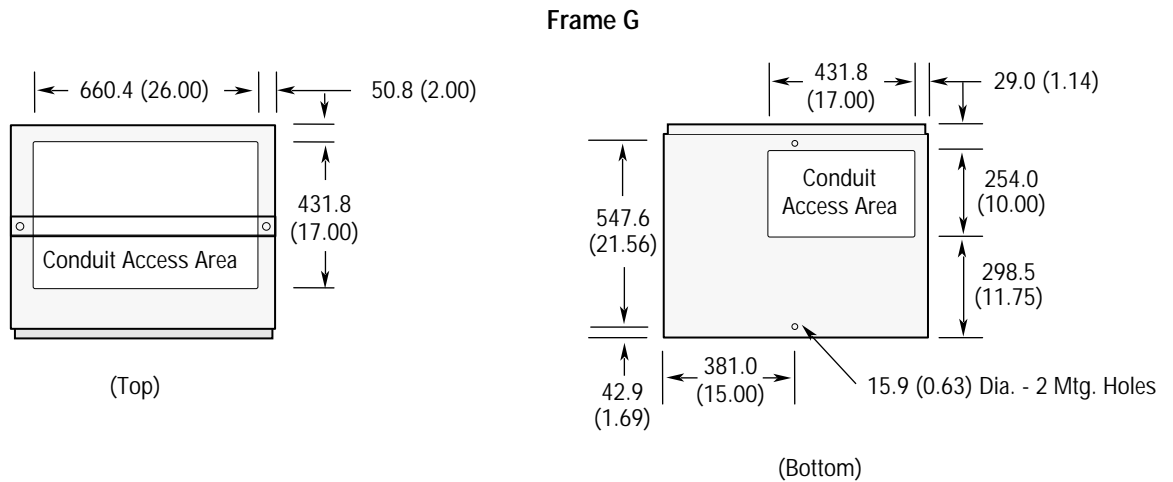
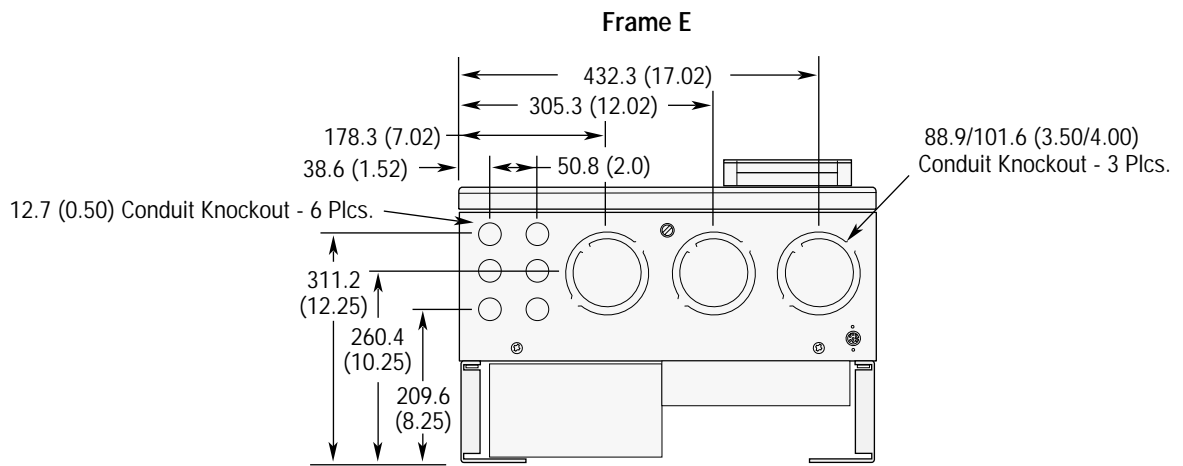
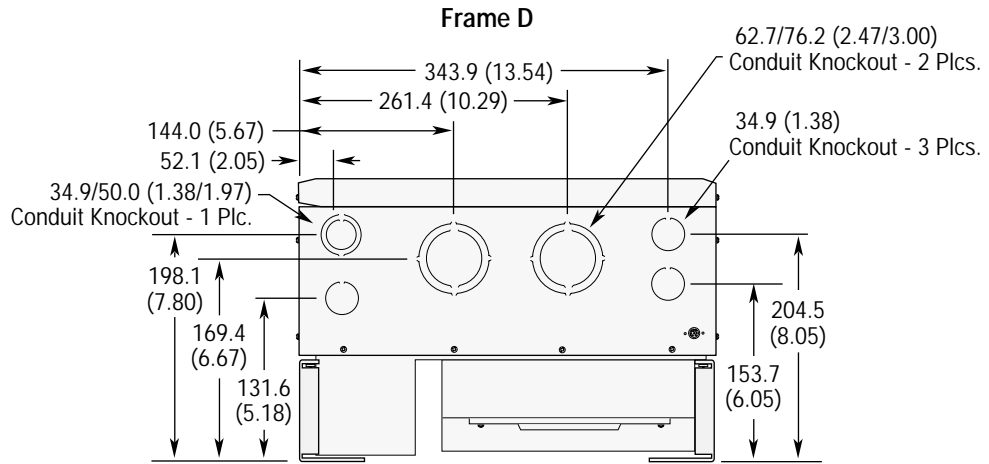


All Dimensions in Millimeters and (Inches)

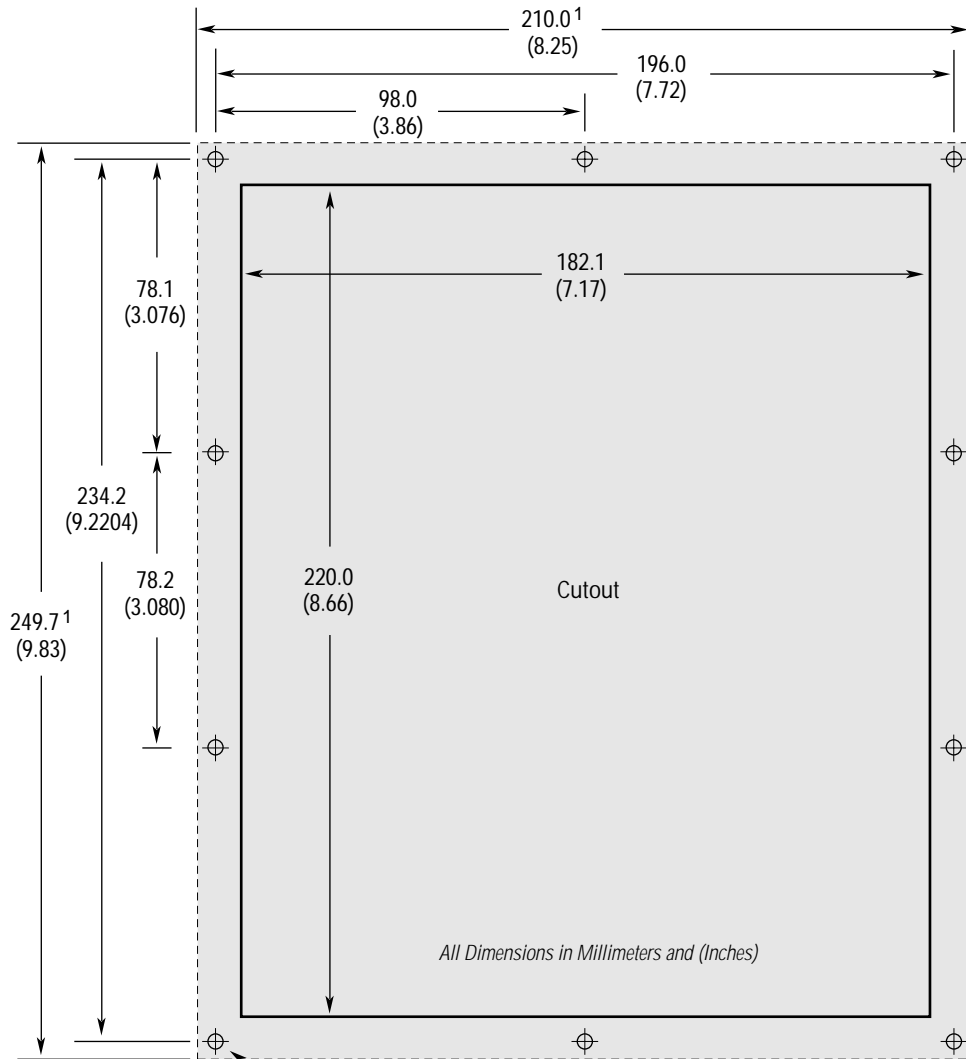
Frame Reference	L	M	P	Q	R	S
B1/B2	181.6 (7.15)	167.1 (6.58)	112.8 (4.44)	163.6 (6.44)	214.4 (8.44)	249.9 (9.84)
C	181.6 (7.15)	167.1 (6.58)	119.1 (4.69)	182.6 (7.19)	233.4 (9.19)	275.3 (10.84)

IP 20 (NEMA Type 1) Bottom View Dimensions - Frames D-G

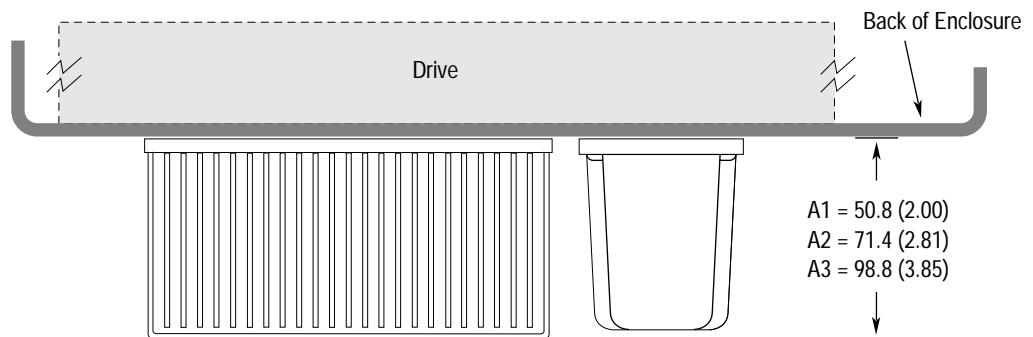
All Dimensions in Millimeters and (Inches)



Heat Sink Through-the-Back Mounting – Frames A1 through A3

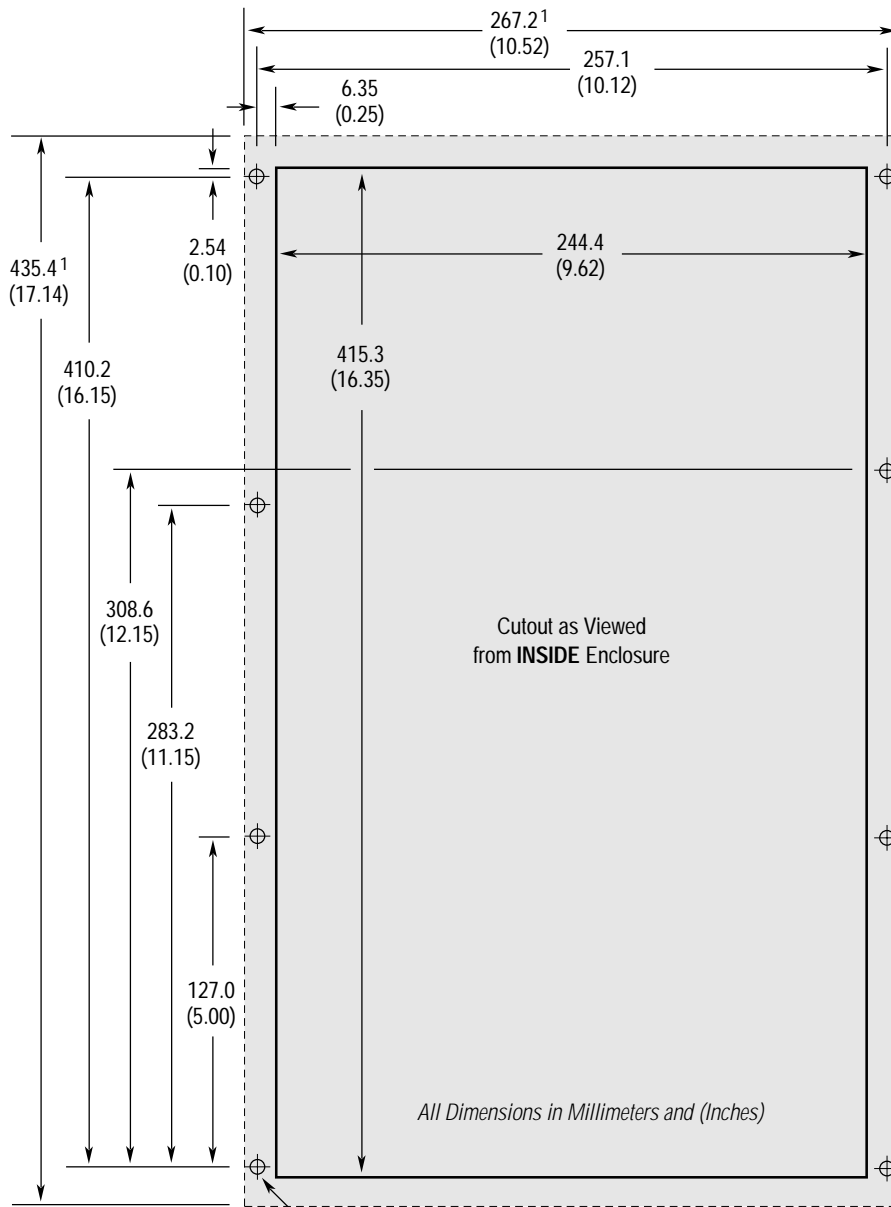


10 Required
 4.3 (0.171) Dia. for 10/32 Taptite® (or equiv.) – 4.0 (0.159) for 10/32 threaded

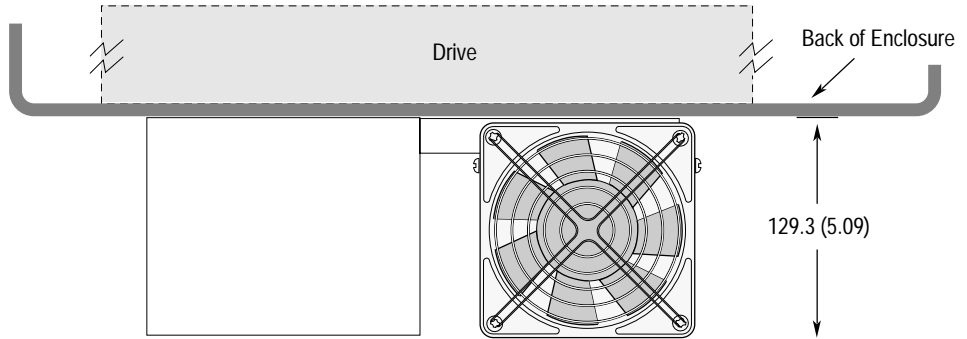


¹ Shading indicates approximate size of drive inside enclosure.

Heat Sink Through-the-Back Mounting – Frame B1/B2

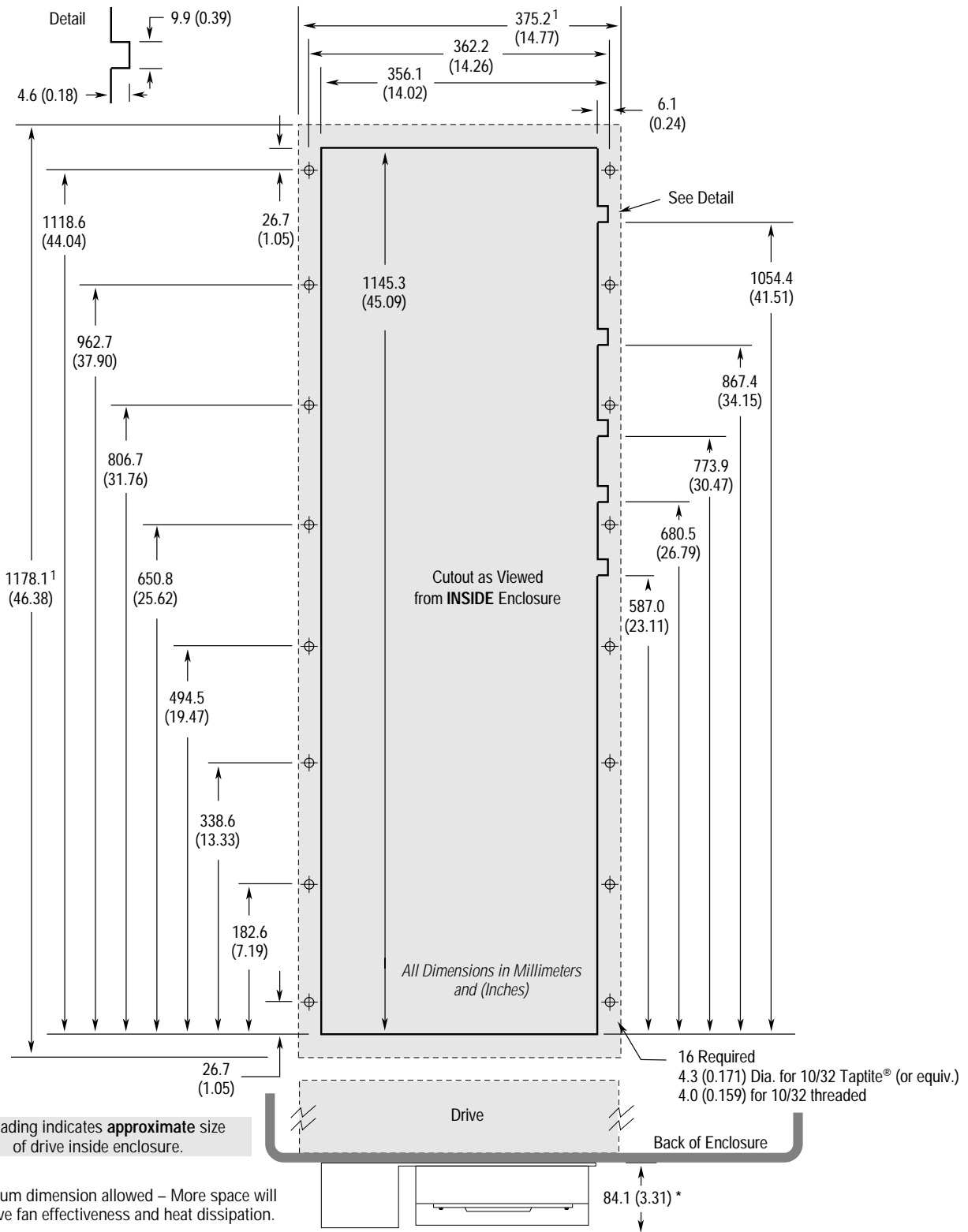


8 Required
4.3 (0.171) Dia. for 10/32 Taplite® (or equiv.) – 4.0 (0.159) for 10/32 threaded

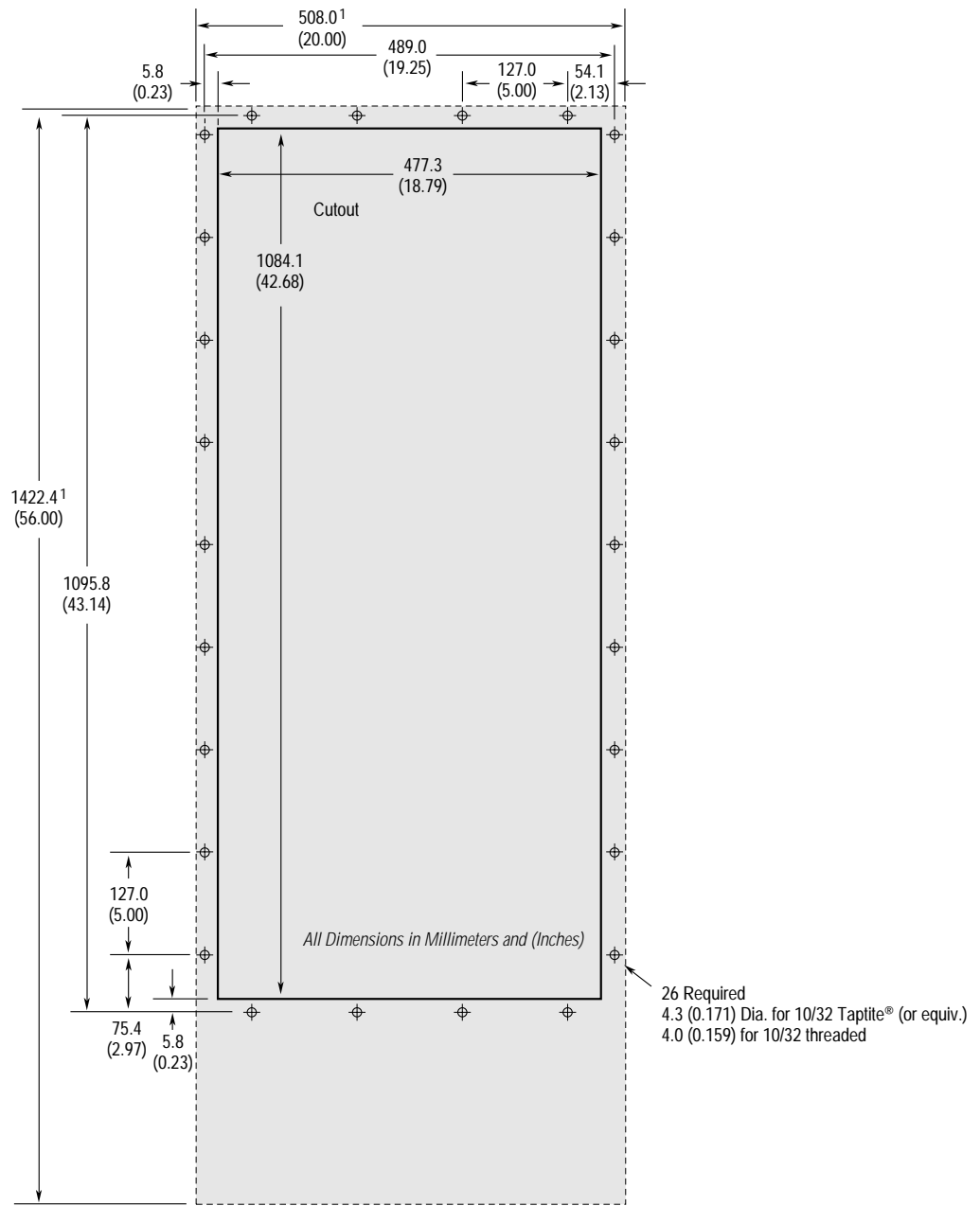


¹ Shading indicates **approximate** size of drive inside enclosure.

Heat Sink Through-the-Back Mounting – Frame D

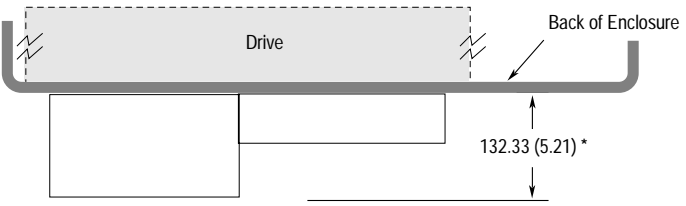


Heat Sink Through-the-Back Mounting – Frame E

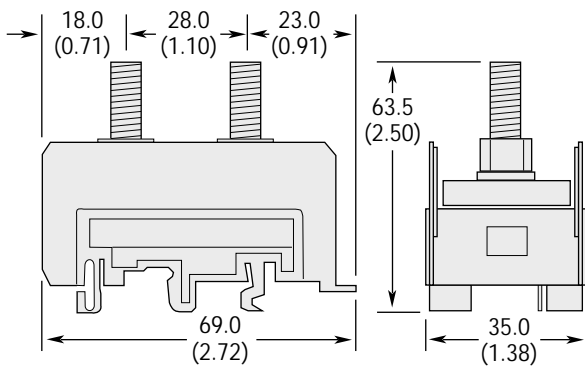
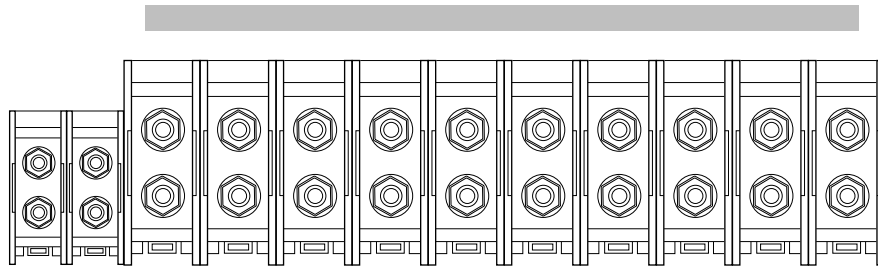
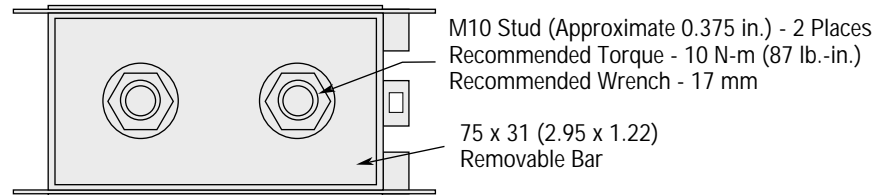
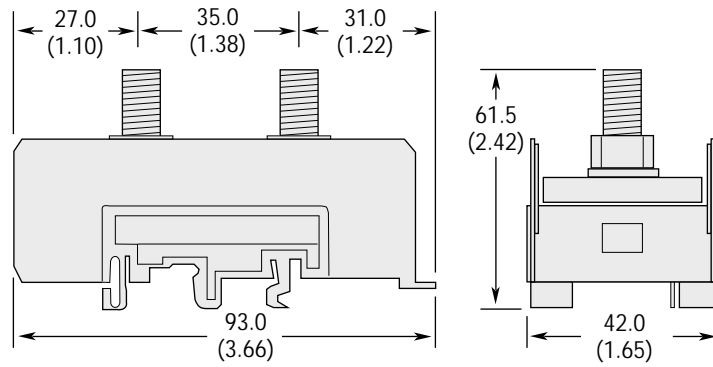


¹ Shading indicates **approximate** size of drive inside enclosure.

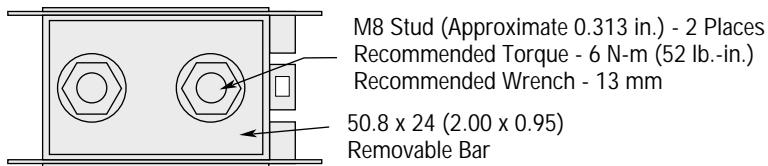
* Minimum dimension allowed – More space will improve fan effectiveness and heat dissipation.



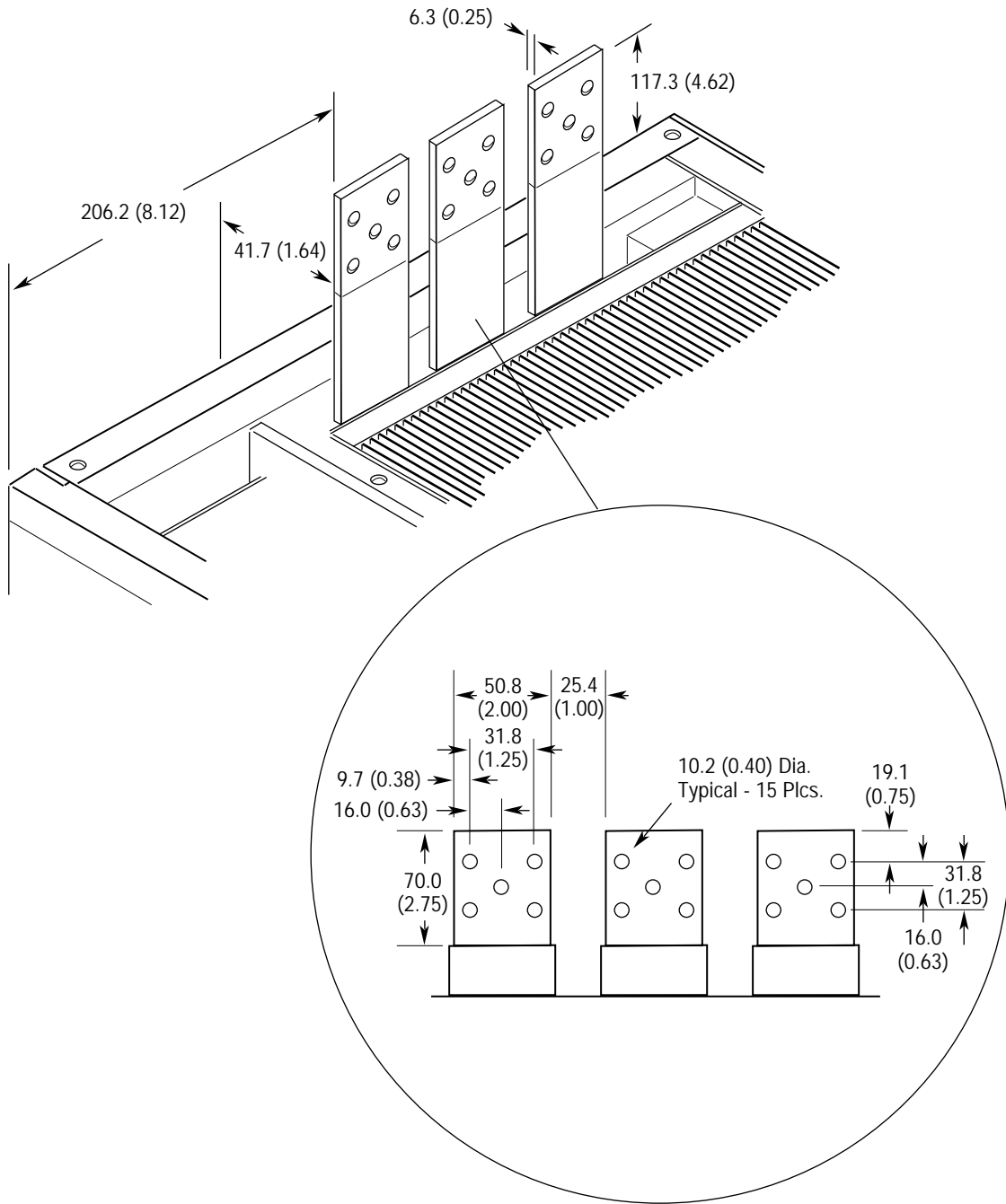
TB1 Dimensions for D & E Frame Drives



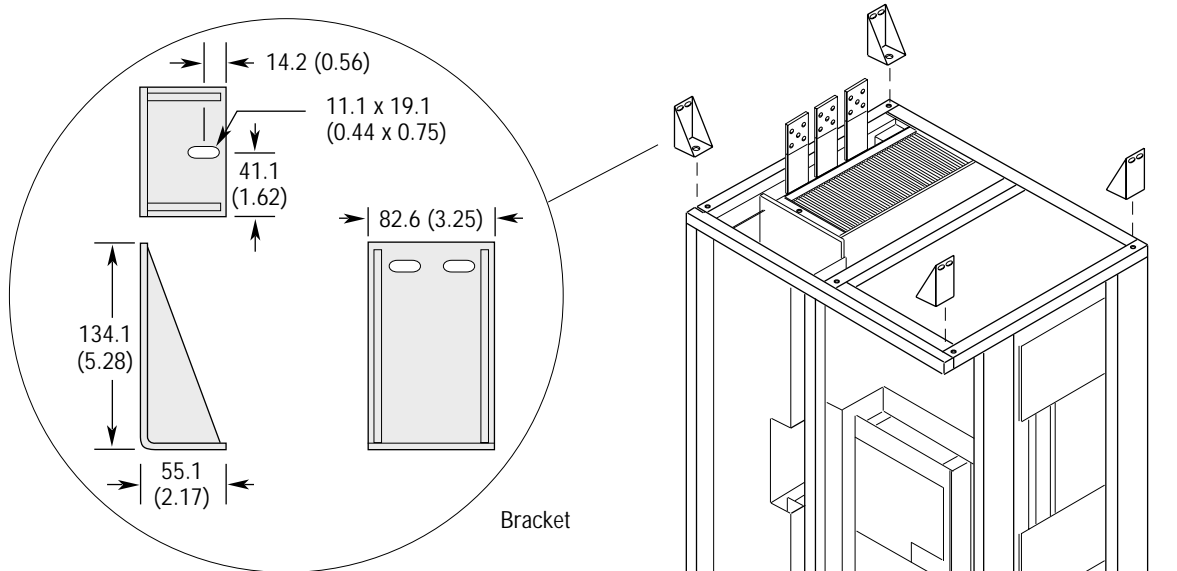
Also applies to TB1 on D Frame Drives



TB1 Dimensions for G Frame Drives

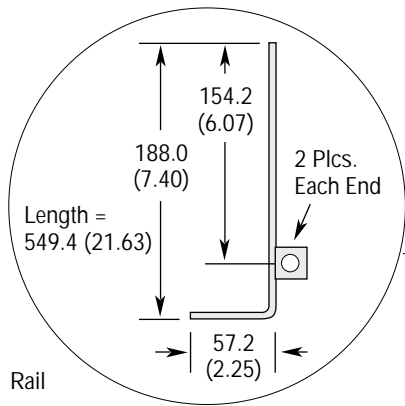


Typical Frame G Mounting in User Supplied Enclosure

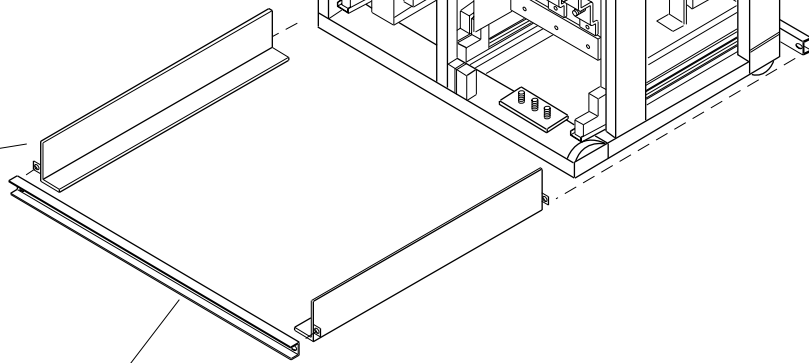


Bracket

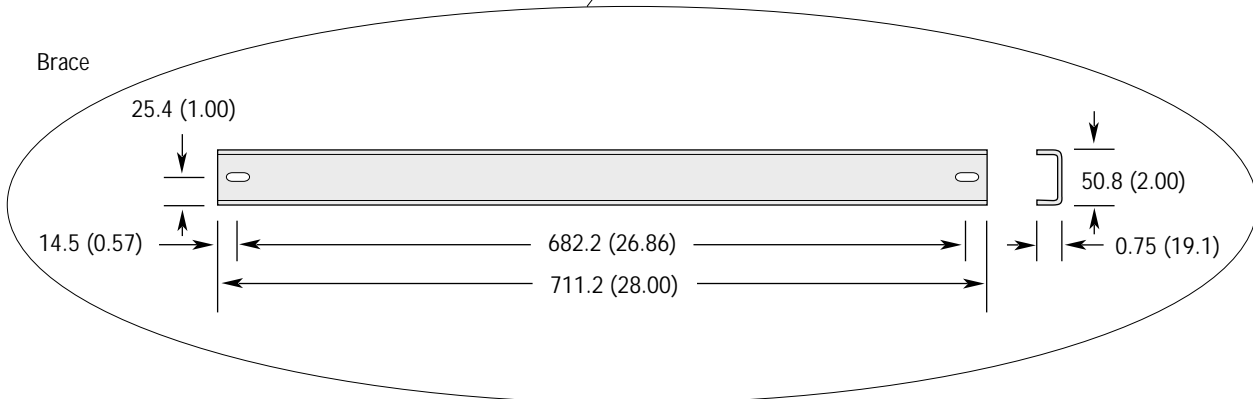
Important: This information represents the method used to factory mount an open type Frame G in an enclosure specifically designed by Allen-Bradley. Illustrations are only intended to identify structural mounting points and hardware shapes. You must design and fabricate steel components based on the actual mounting configuration, calculated loads and enclosure specifications. Minimum thickness of all parts = 4.6 (0.18).



Rail



Brace



CE Conformity

Low Voltage Directive

The following low voltage directives apply:


- EN 60204-1
- PREN 50178

EMC Directive

This apparatus is tested to meet Council Directive 89/336 Electromagnetic Compatibility (EMC) using a technical construction file and the following standards:

- EN 50081-1, -2 – Generic Emission Standard
- EN 50082-1, -2 – Generic Immunity Standard

Declarations of Conformity to the European Union Directives are available. Please contact your Allen-Bradley Sales Representative.

Marked for all applicable directives ¹		
Emissions	EN 50081-1 EN 50081-2 EN 55011 Class A EN 55011 Class B	
Immunity	EN 50082-1 EN 50082-2 IEC 801-1, 2, 3, 4, 6, 8 per EN50082-1, 2	

¹ Note: Installation guidelines stated below must be adhered to.

Important: The conformity of the drive and filter to any standard does not guarantee that the entire installation will conform. Many other factors can influence the total installation and only direct measurements can verify total conformity.

Requirements for Conforming Installation

The following six items **are required** for CE conformance:

1. Standard 1336 PLUS Drive 0.37-448 kW (0.5-600 HP) CE compatible (Series D or higher).
2. Factory installed EMC enclosure (-AE option) or field installed EMC Enclosure Kit (1336x-AEx – see page C-2).
3. Filter as called out on the following page.
4. Grounding as shown on page C-3.
5. Input power (source to filter) and output power (filter to drive & drive to motor) wiring must be braided, shielded cable with a coverage of 75% or better, metal conduit or other with equivalent or better attenuation, mounted with appropriate connectors. For shielded cable it is recommended to use a compact strain relief connector with double saddle clamp for filter and drive input and compact strain relief connector with EMI protection for motor output.
6. Control (I/O) and signal wiring must be in conduit or have shielding with equivalent attenuation.

Filter

Filter Selection

Filter Catalog Number	Three-Phase Volts	Used with . . .	Frame Reference
1336-RFB-7-A	200-240V	1336S-AQF05 - AQF10	A1
	380-480V	1336S-BRF05 - BRF20	A1-A2
1336-RFB-16-A	200-240V	1336S-AQF15 - AQF20	A2
	380-480V	1336S-BRF30 - BRF50	A2-A3
1336-RFB-30-A	200-240V	1336S-AQF30 - AQF50	A3
	380-480V	1336S-BRF75, BRF100	A4
1336-RFB-27-B	200-240V	1336S-A007	B
	380-480V	1336S-B007 - B015	B
1336-RFB-48-B	200-240V	1336S-A010 - A015	B
	380-480V	1336S-B020 - B030	B
1336-RFB-80-C	200-240V	1336S-A020 - A030	C
	380-480V	1336S-BX040 - BX060	C
1336-RFB-150-D	200-240V	1336S-A040 - A050	D
	380-480V	1336S-B060 - B100	D
1336-RFB-180-D	200-240V	1336S-A060	D
	380-480V	1336S-B125 - BX150	D
1336-RFB-340-E	200-240V	1336S-A075 - A125	E
	380-480V	1336S-B150 - B250	E
1336-RFB-475-G	380-480V	1336S-BX250 - B350	G
1336-RFB-590-G	380-480V	1336S-B400 - B450	G
1336-RFB-670-G	380-480V	1336S-B500 - B600	G

EMC Enclosure Kit Selection

Frame Reference	Enclosure Kit Catalog Number		
	200-240V Rating	380-480V Rating	500-600V Rating
A1, A2, A3	1336S-AE3	1336S-AE3	–
A4	1336S-AE2	1336S-AE2	1336S-AE2
B	1336S-AE4	1336S-AE4	1336S-AE4
C	1336S-AE5	1336S-AE5	1336S-AE5
D	1336S-AE6	1336S-AE6	1336S-AE6
E	1336S-AE7	1336S-AE7	1336S-AE7

RFI Filter Installation

Important: Refer to the instructions supplied with the filter for details.

The RFI filter must be connected between the incoming AC supply line and the drive input terminals.

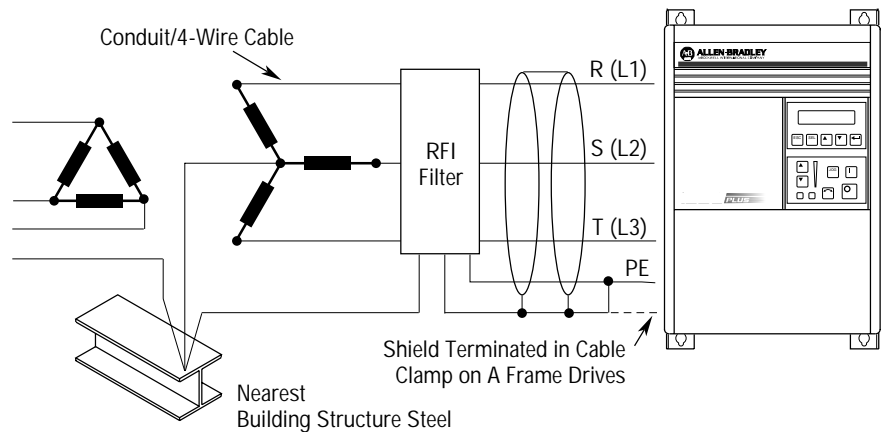
RFI Filter Leakage Current

The RFI filter may cause ground leakage currents. Therefore a solid ground connection must be provided as shown below.



ATTENTION: To guard against possible equipment damage, RFI filters can only be used with AC supplies that are nominally balanced and grounded with respect to ground. In some installations, three-phase supplies are occasionally connected in a 3-wire configuration with one phase grounded (Grounded Delta). The filter must not be used in Grounded Delta supplies.

Electrical Configuration



Grounding

RFI Filter Grounding

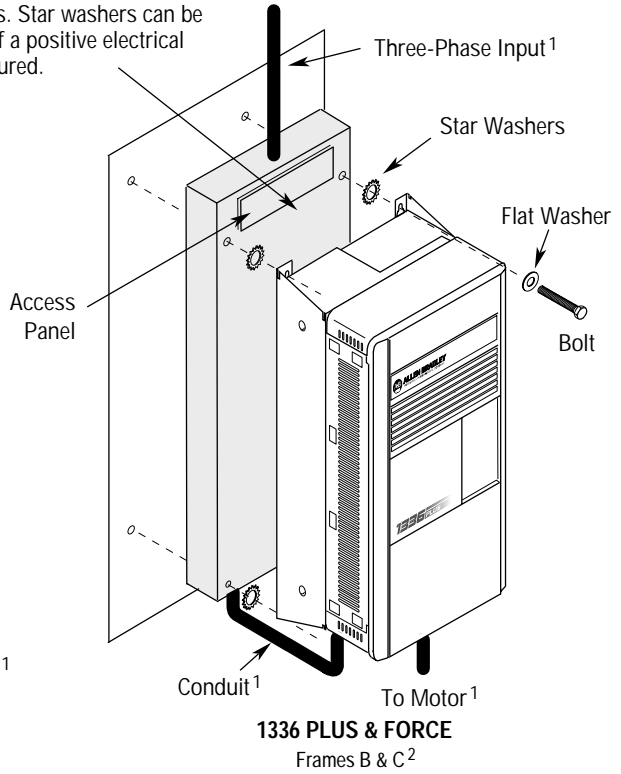
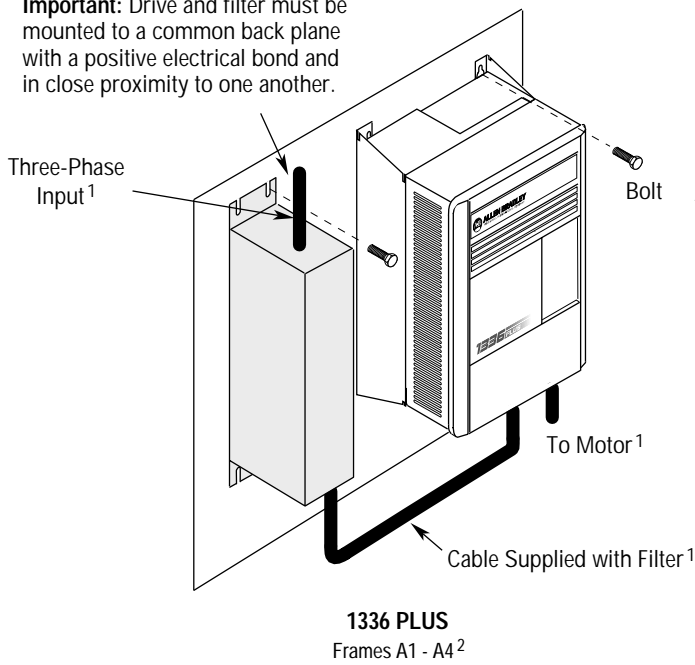
Important: Using the optional RFI filter may result in relatively high ground leakage currents. Surge suppression devices are also incorporated into the filter. Therefore, the filter must be permanently installed and solidly grounded (bonded) to the building power distribution ground. Ensure that the incoming supply neutral is solidly connected (bonded) to the same building power distribution ground.

Grounding must not rely on flexible cables and should not include any form of plug or socket that would permit inadvertent disconnection. Some local codes may require redundant ground connections. The integrity of all connections should be periodically checked.

Mechanical Configuration

Important: Drive and filter must be mounted to a common back plane with a positive electrical bond and in close proximity to one another.

Important: A positive electrical bond must be maintained between drive and filter at all 4 corners. Star washers can be eliminated if a positive electrical bond is assured.

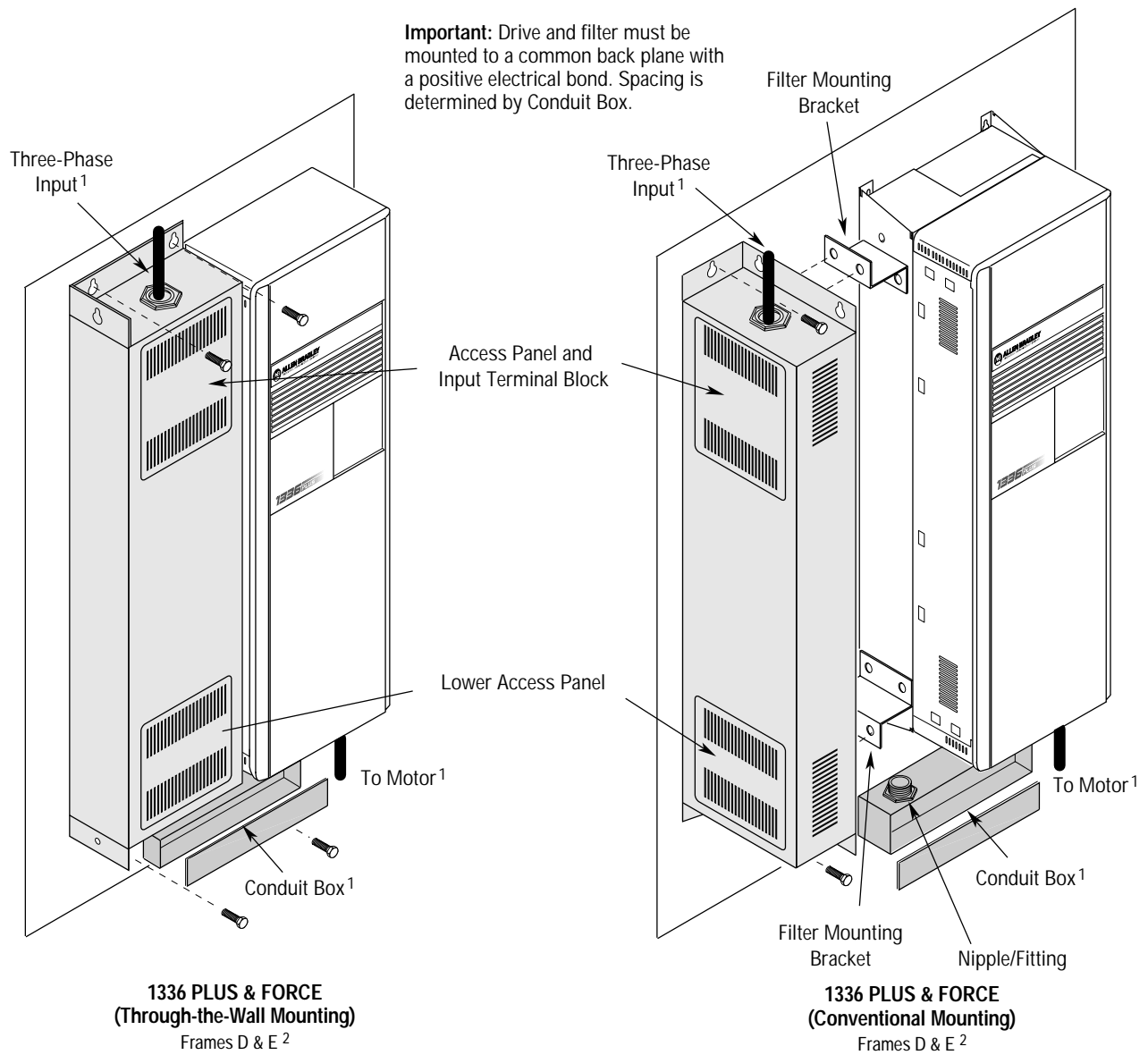


¹ Input power (source to filter) and output power (filter to drive and drive to motor) wiring must be in conduit or have shielding/armor with equivalent attenuation. Shielding/armor must be bonded to the metal bottom plate. See requirements 6 & 7 on page C-1.

² Refer to the Filter Selection table on page C-2 for frame references and corresponding catalog numbers.

Filter Mounting (continued)

Important: Drive and filter must be mounted to a common back plane with a positive electrical bond. Spacing is determined by Conduit Box.



¹ Input power (source to filter) and output power (filter to drive and drive to motor) wiring must be in conduit or have shielding/armor with equivalent attenuation. Shielding/armor must be bonded to the metal bottom plate. See requirements 6 & 7 on page C-1.

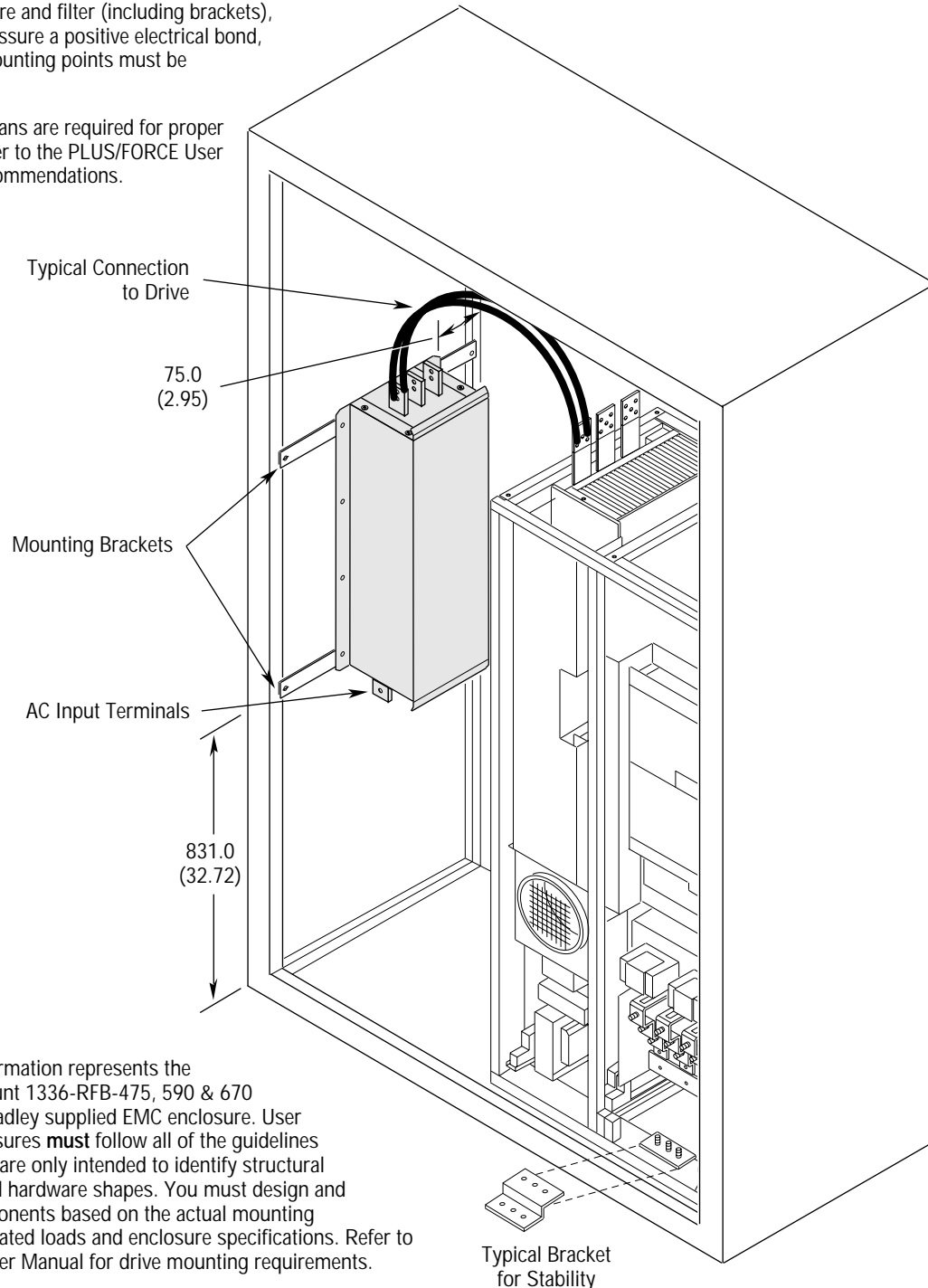
² Refer to the Filter Selection table on page C-2 for frame references and corresponding catalog numbers.

Filter Mounting (continued)

All Dimensions in Millimeters and (Inches)

Important: A positive electrical bond must be maintained between the enclosure and filter (including brackets), fans, and drive. To assure a positive electrical bond, any paint near all mounting points must be removed.

Important: Cooling fans are required for proper drive operation. Refer to the PLUS/FORCE User Manual for CFM recommendations.



Important: This information represents the method used to mount 1336-RFB-475, 590 & 670 filters in an Allen-Bradley supplied EMC enclosure. User supplied EMC enclosures **must** follow all of the guidelines shown. Illustrations are only intended to identify structural mounting points and hardware shapes. You must design and fabricate steel components based on the actual mounting configuration, calculated loads and enclosure specifications. Refer to the PLUS/FORCE User Manual for drive mounting requirements.

1336 PLUS & FORCE (Typical Mounting)

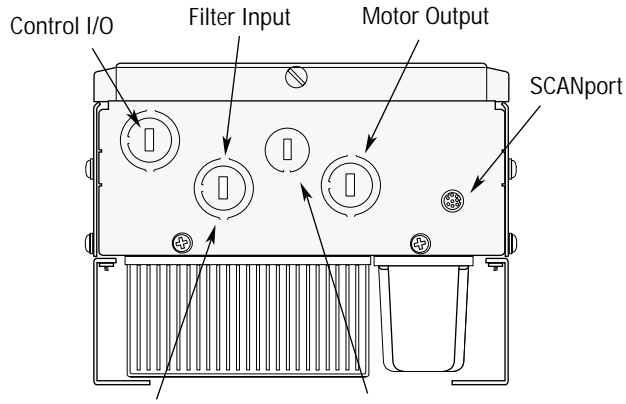
Frame G²

- ¹ Input power (source to filter) and output power (filter to drive and drive to motor) wiring must be in conduit or have shielding/armor with equivalent attenuation. Shielding/armor must be bonded to the metal bottom plate. See requirements 6 & 7 on page C-1.
- ² Refer to the Filter Selection table on page C-2 for frame references and corresponding catalog numbers.

Required Knockout Assignments

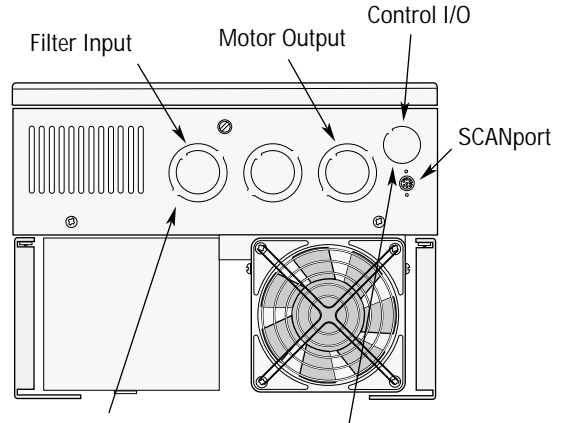
Dimensions are in Millimeters and (Inches)

Frames A1 through A4



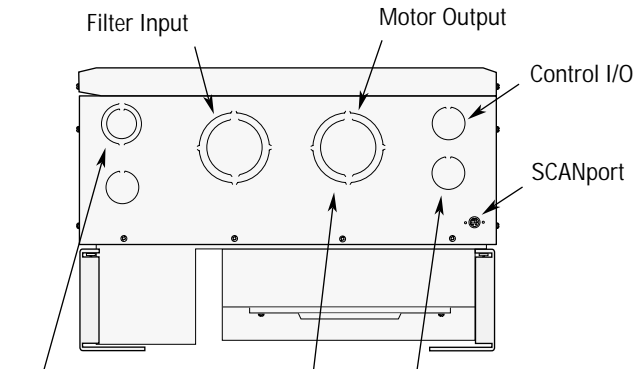
22.2/28.6 (0.88/1.13) - 3 Plcs. 22.2 (0.88) - 1 Plc.

Frames B and C



28.6/34.9 (1.13/1.38) - 3 Plcs. 22.2 (0.88) - 1 Plc.

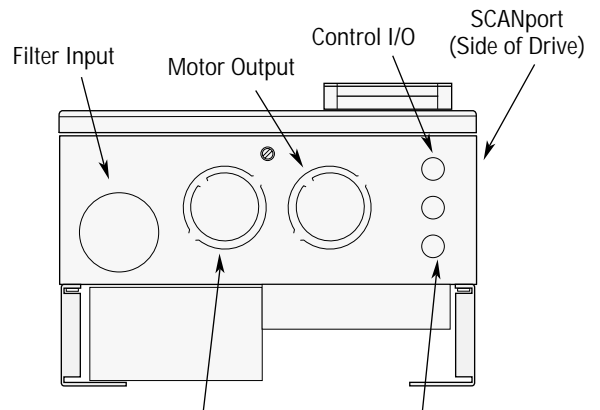
Frame D



34.9/50.0 (1.38/1.97) - 1 Plc. 34.9 (1.38) - 3 Plcs.

62.7/76.2 (2.47/3.00) - 2 Plcs.

Frame E



88.9/104.8 (3.50/4.13) - 2 Plcs. 12.7 (0.50) - 3 Plcs.

End of Appendix

Spare Parts Information

Current 1336 PLUS spare parts information including recommended parts, catalog numbers and pricing can be obtained from the following sources:

- Allen-Bradley home page on the World Wide Web at **<http://www.ab.com>**
then select . . .
“Drives” followed by . . .
“Product Information” and . . .
“Service Information . . .”
- Standard Drives “AutoFax” service – an automated system that you can call to request a “faxed” copy of the spare parts information (or other technical document).

Simply call **216-646-6701 (440-646-6701 after 8/16/97)** and follow the phone prompts to request document(s) **1060** (230V drives) and/or **1070** (460 & 575V drives).

End of Appendix

A

AC Supply Source, 2-3
Adapter Definitions, 2-38
Alarms, 6-8
Analog Invert, 5-15
Auto Restart, 5-22

B

Bypass Contactors, 2-6

C

Cable Termination, 2-34
Catalog Number Explanation, 1-2
CE Conformity, 2-8, C-1
Common Mode Cores, 2-34
Contacts, Fault, 6-1
Control Interface Option
 Board Removal/Installation, 2-37
 L4/L4E, 2-30
 L5/L5E, 2-31
 L6/L6E, 2-32
 TB3 Description, 2-25
Control Status Mode, 3-5
Custom Volts/Hz, 5-51

D

DC Brake to Stop, 5-17
Derate Guidelines, A-5
Dimensions
 Frame G Mounting Hardware, B-18
 Heat Sink Through the Back, B-10,
 B-11
 IP 20 (NEMA Type 1)
 Bottom Views, B-8
 Front Views, B-2
 IP 65/54 (NEMA Type 4/12),
 Enclosure, B-7
 TB1 - Frame G, B-17
 TB1 - Frames D & E, B-16
Display Mode, 3-5
Distances Between Devices, 2-38
Distribution Systems
 Unbalanced, 2-3
 Ungrounded, 2-3
Drive Status Structure, A-13
Dwell, 5-21

E

EEProm Mode, 3-5
Electrostatic Discharge (ESD), 1-2
Encoder Wiring, 2-32
Engineering Unit, 5-6
ENUM, 5-6

F

Fan Voltage, Selecting/Verifying, 2-35
Fault Buffer History, 5-29
Faults
 Adptr Freq Err, 6-2
 Auxiliary, 6-2
 BGND 10ms Over, 6-2
 Blwn Fuse Flt, 6-2
 Diag C Lim Flt, 6-2
 Drive -> HIM, 6-2
 Drive Fault Reset, 6-2
 EE Init Read, 6-2
 EE Init Value, 6-2
 EEProm Checksum, 6-2
 EEProm Fault, 6-2
 FGND 10ms Over, 6-2
 Ground Fault, 6-3
 Ground Warning, 6-3
 Hertz Err Fault, 6-3
 Hertz Sel Fault, 6-3
 HIM -> Drive, 6-3
 Loop Overrn Flt, 6-3
 Max Retries Fault, 6-3
 Motor Mode Flt, 6-3
 Motor Stall Fault, 6-4
 Neg Slope Fault, 6-4
 Op Error Fault, 6-4
 Open Pot Fault, 6-4
 Overcurrent Flt, 6-4
 Overload Fault, 6-4
 Overtemp Fault, 6-4
 Overvolt Fault, 6-4
 P Jump Err Flt, 6-5
 Phase U Fault, 6-4
 Phase V Fault, 6-5
 Phase W Fault, 6-5
 Poles Calc Flt, 6-5
 Power Loss Fault, 6-5
 Power Mode Fault, 6-5
 Power Overload, 6-5
 Power Test Flt, 6-5
 Precharge Fault, 6-5
 Precharge Open, 6-5
 Reprogram Fault, 6-6
 ROM or RAM Fault, 6-6

- Run Boost Fault, 6-6
 - Serial Fault, 6-6
 - Shear Pin Fault, 6-6
 - Temp Sense Open, 6-6
 - Undervolt Fault, 6-6
 - UV Short Fault, 6-6
 - UW Short Fault, 6-6
 - VW Short Fault, 6-6
 - Xsistr Desat Flt, 6-6
 - Filtering, RFI, 2-8, 2-9, C-3
 - Frame References, 1-1
 - Frequency Select, 5-19
 - Function Index, 5-1
 - Fusing, Input, 2-5
- G**
- Grounding, 2-8
- H**
- Human Interface Module (HIM)
 - Character Map, A-12
 - Description, 3-1
 - Key Descriptions, 3-2
 - Operation, 3-4
 - Removal, 3-15
- I**
- Input Devices, 2-6
 - Input Mode Selection, 2-28
 - Input Power Conditioning, 2-4
 - Input/Output Rating, A-2
 - Interference, EMI/RFI, 2-7
 - Isolation Transformer, 2-4
- L**
- L4/L4E Option, 2-30
 - L5/L5E Option, 2-31
 - L6/L6E Option, 2-32
 - Line Loss Restart, 5-30
 - Logic Control Structure, A-13
 - Low Speed Operation, 4-10
 - Lug Kits, 2-12
- M**
- Min./Max. Frequency, 5-11
 - Motor Cable Length, 2-15
 - Motor Starting/Stopping, 2-6
 - Mounting, 2-1
- N**
- Nameplate Location, 1-4
- O**
- Output Configuration, 5-26
 - Output Devices, 2-34
 - Overload, 5-13
- P**
- Parameter Cross Ref.
 - By Name, A-11
 - By Number, A-10
 - Parameter Record, A-16
 - Parameters
 - % Output Curr, 5-9
 - % Output Power, 5-9
 - 0-10 Volt Hertz, 5-8
 - 2nd Drive Sts, 5-34
 - 4-20 mA Hertz, 5-8
 - 4-20 mA Loss Sel, 5-16
 - Abs Analog Out, 5-28
 - Accel Mask, 5-40
 - Accel Owner, 5-42
 - Accel Time, 5-10, 5-16
 - Adaptive I Lim, 5-12
 - Alarm Mask, 5-41
 - Analog Invert, 5-15
 - Analog Out Sel, 5-28
 - Analog Trim En, 5-15
 - Anlg Out Offset, 5-28
 - Base Frequency, 5-53
 - Base Voltage, 5-53
 - Blwn Fuse Flt, 5-31
 - Boost Slope, 5-52
 - Break Frequency, 5-52
 - Break Voltage, 5-52
 - Bus Limit En, 5-18
 - Clear Fault, 5-29
 - Control Select, 5-51
 - CR Out Select, 5-26
 - Cur Lim Trip En, 5-29
 - Current Angle, 5-37
 - Current Limit, 5-11
 - Current Lmt Sel, 5-12
 - Data In, 5-43
 - Data Out, 5-43
 - DC Boost Select, 5-14
 - DC Bus Memory, 5-37
 - DC Bus Voltage, 5-7

DC Hold Level, 5-17
DC Hold Time, 5-17
Decel Mask, 5-40
Decel Owner, 5-42
Decel Time, 5-10, 5-16
Dig Out Current, 5-26
Dig Out Freq, 5-26
Dig Out Torque, 5-27
Digital Out Sel, 5-26
Direction Mask, 5-39
Direction Owner, 5-41
Drive Alarm, 5-34
Drive Direction, 5-35
Drive Rtd Volts, 5-38
Drive Status, 5-34
Drive Type, 5-38
Dwell Frequency, 5-21
Dwell Time, 5-21
EEPROM Cksum, 5-37
Encoder Type, 5-45
Fault Alarms, 5-33
Fault Buffer, 5-29
Fault Data, 5-31
Fault Frequency, 5-32
Fault Mask, 5-40
Fault Owner, 5-42
Firmware Ver., 5-38
Flt Clear Mode, 5-33
Flt Driv Status, 5-32
Flt Motor Mode, 5-31
Flt Power Mode, 5-32
Flux Amps Ref, 5-51
Flux Current, 5-9
Flux Up Time, 5-52
Flying Start En, 5-24
Freq Command, 5-7, 5-35
Freq Ref SqRoot, 5-20
Freq Select, 5-10, 5-19
Freq Source, 5-35
FStart Forward, 5-24
FStart Reverse, 5-24
Ground Warning, 5-33
Heatsink Temp, 5-8, 5-37
Hold Level Sel, 5-17
Input Mode, 5-10, 5-26
Input Status, 5-35
IR Drop Volts, 5-52
Jog Frequency, 5-19
Jog Mask, 5-39
Jog Owner, 5-42
KI Amps, 5-18
KI Process, 5-49
KP Amps, 5-18
KP Process, 5-49
Language, 5-24
Last Fault, 5-9
Latched Alarms, 5-35
Line Loss Fault, 5-29
LLoss Restart, 5-24
Local Mask, 5-40
Local Owner, 5-42
Logic Mask, 5-40
Low Bus Fault, 5-31
Max Traverse, 5-25
Maximum Freq, 5-11, 5-14
Maximum Speed, 5-45
Maximum Voltage, 5-53
Minimum Freq, 5-11, 5-14
MOP Hertz, 5-8
MOP Increment, 5-20
MOP Mask, 5-40
MOP Owner, 5-42
Motor Mode, 5-36
Motor NP Amps, 5-13
Motor NP Hertz, 5-13, 5-46
Motor NP RPM, 5-13, 5-46
Motor NP Volts, 5-13
Motor OL Count, 5-9
Motor OL Fault, 5-29
Motor Poles, 5-45
Motor Type, 5-18
Output Current, 5-7
Output Freq, 5-7
Output Power, 5-7
Output Pulses, 5-37
Output Voltage, 5-7
Overload Amps, 5-13
Overload Mode, 5-12
P Jump, 5-25
PI Config, 5-47
PI Error, 5-49
PI Fdbk Select, 5-48
PI Feedback, 5-49
PI Neg Limit, 5-49
PI Output, 5-49
PI Pos Limit, 5-49
PI Preload, 5-50
PI Ref Select, 5-48
PI Reference, 5-48
Pot Hertz, 5-8
Power Mode, 5-36
Power OL Count, 5-9
Preset Freq, 5-19
Process 1 Par, 5-44
Process 1 Scale, 5-44
Process 1 Txt, 5-44
Process 2 Par, 5-44
Process 2 Scale, 5-44
Process 2 Txt, 5-44
Pulse/Enc Hertz, 5-8, 5-46
Pulse/Enc Scale, 5-21, 5-45
PWM Frequency, 5-15
Rated Amps, 5-38
Rated CT Amps, 5-38

Rated CT kW, 5-39
 Rated kW, 5-38
 Rated VT Amps, 5-39
 Rated VT kW, 5-39
 Reference Mask, 5-40
 Reference Owner, 5-42
 Reset/Run Time, 5-23
 Reset/Run Tries, 5-22
 Run Boost, 5-52
 Run On Power Up, 5-22
 Run/Accel Boost, 5-15
 S Curve Enable, 5-23
 S Curve Time, 5-23
 Save MOP Ref, 5-20
 Set 0-10 Vlt Hi, 5-27
 Set 0-10 Vlt Lo, 5-27
 Set 4-20 mA Hi, 5-27
 Set 4-20 mA Lo, 5-27
 Set Anlg Out Hi, 5-28
 Set Anlg Out Lo, 5-28
 Set Defaults, 5-37
 Shear Pin Fault, 5-29
 Skip Freq, 5-20
 Skip Freq Band, 5-20
 Slip Comp Gain, 5-22
 Slip@F.L.A., 5-22
 Speed Adder, 5-46
 Speed Control, 5-22, 5-45, 5-47
 Speed Error, 5-46
 Speed Integral, 5-46
 Speed KI, 5-46
 Start Boost, 5-52
 Start Mask, 5-39
 Start Owner, 5-41
 Stop Mode Used, 5-36
 Stop Owner, 5-41
 Stop Select, 5-11, 5-16, 5-18
 Torque Current, 5-9
 Traverse Period, 5-25
 VT Scaling, 5-13
 Password Mode, 3-5
 Power Loss Ride-Thru, 5-30
 Preset Frequency, 5-19
 Process Mode, 3-5
 Program Mode, 3-5
 Programmable Controller Config., A-14
 Programming Flow Chart, 5-1
 Pulse Input, 2-23

R

Reactors, 2-4
 Remote I/O, 5-43

Reset Defaults, 4-3

S

S Curve, 5-23
 Search Mode, 3-5
 Serial Communications, A-13
 Skip Frequency, 5-20
 Software Compatibility, 1-1
 Specifications
 Control, A-2
 Electrical, A-2
 Environment, A-1
 Input/Output Ratings, A-2
 Protection, A-1
 Flux Vector vs. V/Hz, 4-5, 4-11
 Speed Select Inputs, 2-26
 Startup Procedure, 4-1
 Status Display, 3-5

T

Terminal Blocks
 Auxiliary Output, 2-37
 Locations, 2-11
 TB1, 2-12
 TB2, 2-22
 TB3, 2-25
 TB4/TB6, 2-36
 Traverse Function, 5-25
 Troubleshooting
 Clearing a Fault, 6-1
 Fault Code Cross Ref., 6-7
 Fault Descriptions, 6-1
 Fault Display, 6-1

U

User Supplied Enclosures, A-4

V

Volts/Hz Pattern, 5-51

W

Wiring
 Control and Signal, 2-21
 Control Interface, 2-23
 Encoder, 2-32
 Power, 2-11

www.rockwellautomation.com

Power, Control and Information Solutions Headquarters

Americas: Rockwell Automation, 1201 South Second Street, Milwaukee, WI 53204-2496 USA, Tel: (1) 414.382.2000, Fax: (1) 414.382.4444

Europe/Middle East/Africa: Rockwell Automation, Vorstlaan/Boulevard du Souverain 36, 1170 Brussels, Belgium, Tel: (32) 2 663 0600, Fax: (32) 2 663 0640

Asia Pacific: Rockwell Automation, Level 14, Core F, Cyberport 3, 100 Cyberport Road, Hong Kong, Tel: (852) 2887 4788, Fax: (852) 2508 1846

Publication 1336 PLUS-5.0 – April, 2001

P/N 74001-003-01

Supersedes 1336 PLUS-5.0 – September, 2000, 1336 PLUS-5.3DU3 – October, 1998 and 1336S-DU002A-EN-P – September, 2000

Copyright 2001 Rockwell International Corporation. All rights reserved. Printed in USA.