

Configurable AC Drive Packages Flexibility with Definition

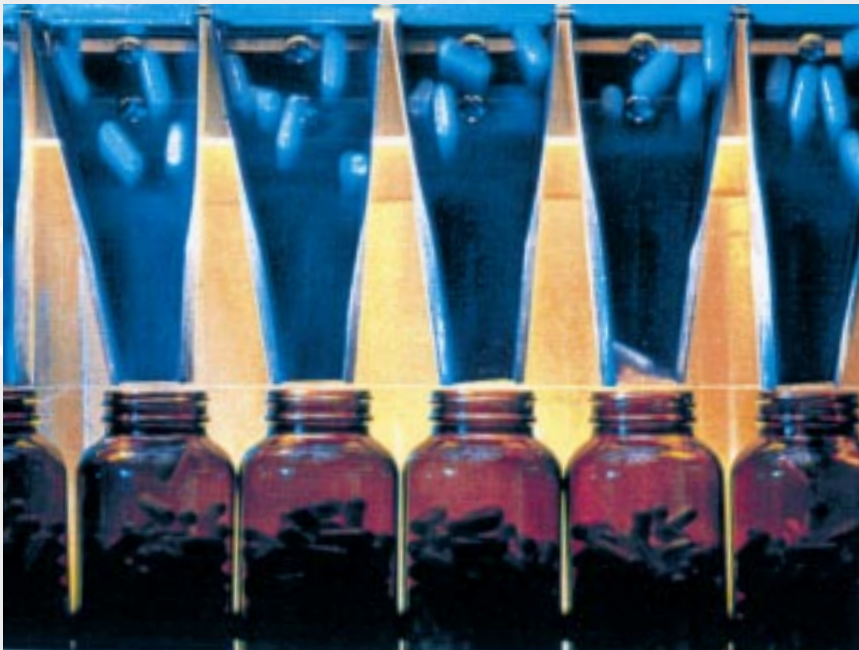

efesotomasyon.com

1336 PLUS Configured AC Drives Program



SENSORLESS VECTOR



Configured to *Your* Application Requirements

The Configured Drives Program allows you to order specifically configured drives packages that exceed the offerings of a standard drive product. The expanded options list includes control, communications, power, packaging and documentation. Packaging is available in NEMA Type 1, 4 or 12 enclosures.

The capabilities of this program range from supplying simple, commonly requested pre-engineered options to more complex, specifically engineered requirements.

Available in ratings of 0.37 – 93 kW (0.5 – 125 HP) at 230 volts, 0.37 – 448 kW (0.5 – 600 HP) at 460 volts, and 0.75 – 448 kW (1 – 600 HP) at 575 volts. **1336 PLUS Configured Drives provide a single solution to virtually all of your requirements for speed control, motor protection and system interface.**



Standard 1336 PLUS Variable Frequency Drive with Programming Panel



Configured 1336 PLUS Package



Pilot Devices on enclosure door

A Comprehensive Drives Line with an Abundant Family of Options

Commonality of design across the entire product range, combined with identical control interface functions, device communications, training and maintenance provides a tremendous advantage to our customers.

Performance Features Needed for Today's Applications

Enhanced features include:

- **SENSORLESS VECTOR** control for excellent torque at all speeds
- Volts/Hertz operation available through parameter selection
- Proactive current limit for high performance and application flexibility
- Optional encoder feedback for 0.1% speed regulation
- Speed-sensitive I^t programmable electronic overload protection for motor protection at any speed
- Flying start for powering into a spinning motor
- S-curve acceleration and deceleration for smooth control of speed changes
- Integral PI software for simple process control
- Adjustable carrier frequency
- SCANport™ communications protocol for operator interface and communications options
- Two-line process display

Product Support for Quick Delivery

Most of the available options in the Configured Drives Program are completely pre-defined and manufacturing begins immediately after order entry. Many other options are processed through the Quick Turn (Q/T) Work Cell and may require minimal additional handling. More complex option choices will require varying amounts of engineering and special handling, with delivery time varying by complexity.

Definition: Complete and Detailed Product Documentation

All Allen-Bradley Configured Drives are supplied with instruction manuals and complete, order-specific drawings. Special documentation and test requirements will also be supplied as requested. Support publications are available to assist in custom configuration and ordering special drive packages.



200 HP 460V NEMA Type 1 Drive with Bypass Capability



15 HP 230V NEMA Type 1 Drive

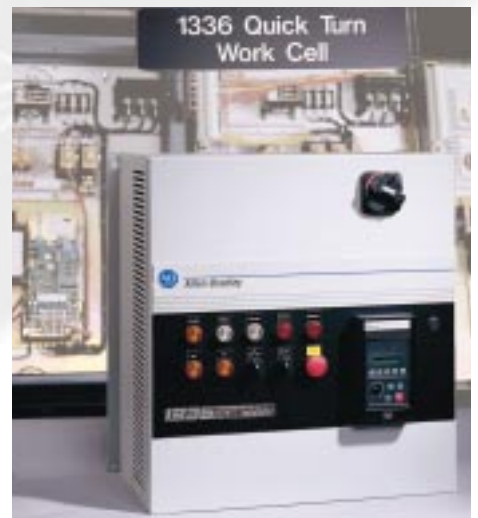

The Quick Turn-around Center provides assembly and shipment of common configurations in a significantly reduced cycle time.

Standard Drive Features

Performance and Simplicity in One Package

A high performance drive utilizing laminar bus structure, planar construction, IGBT technology and a variety of other enhancements provides simplicity at its best.

Third Generation IGBTs

- Quiet motor operation
- Quality output waveform for excellent motor torque
- High performance for smaller package size

Language Modules

- Support multiple languages through the use of plug-in modules

Communications Interface

- Internal and external communication option kits available

Logic Interface Options

- Contact Closure
- 24V AC/DC
- 120V AC

Agency Certification

- UL Listed ¹
- CSA Certified ¹

¹ Some options or special packaging may not qualify.



Human Interface Module

- Multiple languages for global flexibility
- Parameter organization to speed setup for common applications
- Built-in diagnostics
- Setup and diagnostic information in plain language statements – no codes or numbers to remember
- Upload/download capability to capture & reuse drive programming

Laminar Bus Structure

- Unique designs to increase IGBT performance

Variety of Enclosure Options

- 5 specific packaging programs for complete application flexibility

Input Voltages

- 230V AC
- 460V AC
- 575V AC

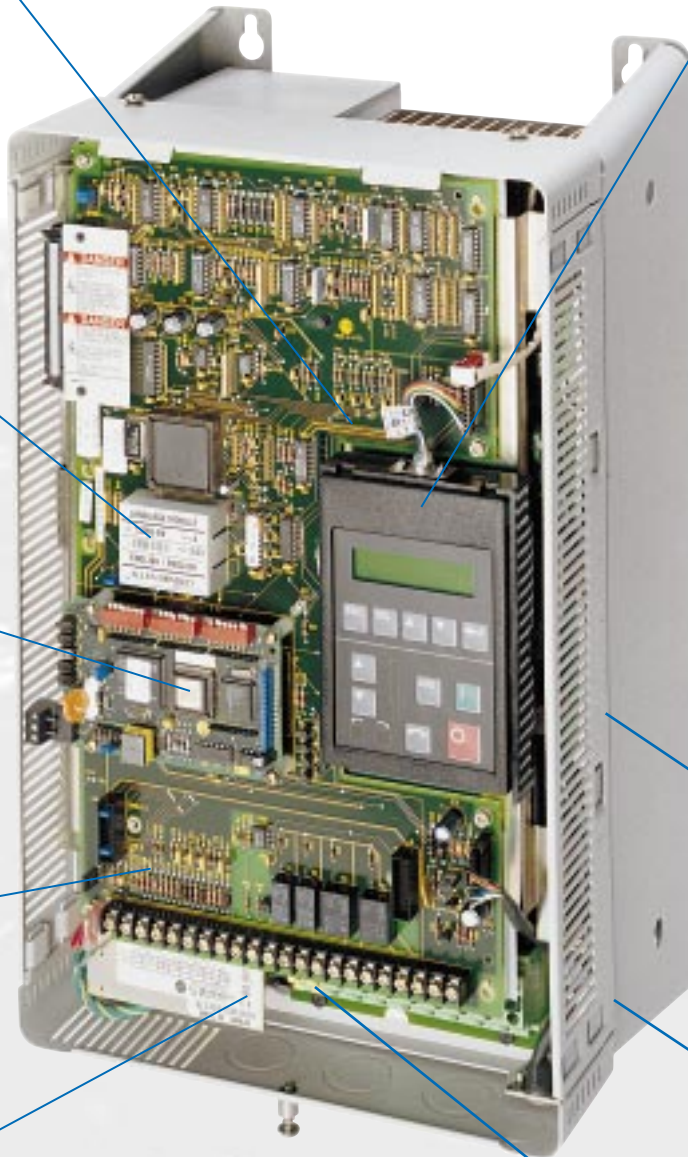

Human Interface Modules (HIM)

The Human Interface Module is a two-line by sixteen-character, “super-twist” backlit LCD display. All information is easy to read and understand without any decoding.

The Human Interface Module is used with all Allen-Bradley 1305, 1336 PLUS, 1336 IMPACT™ and 1336 FORCE™ drives, and SMC Dialog Plus™ softstarter products.

Parameters are grouped by logical function to simplify programming and troubleshooting.

The Human Interface Module is available in three different configurations allowing you to choose between programming with or without analog or digital speed control.

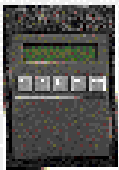

Programmer Only

Provides programming functionality from the local panel.



Analog Speed Potentiometer

Provides analog speed control and programming functionality from the local panel.



Digital Up/Down Push Button Speed Control

Provides digital speed control and programming functionality from the local panel.

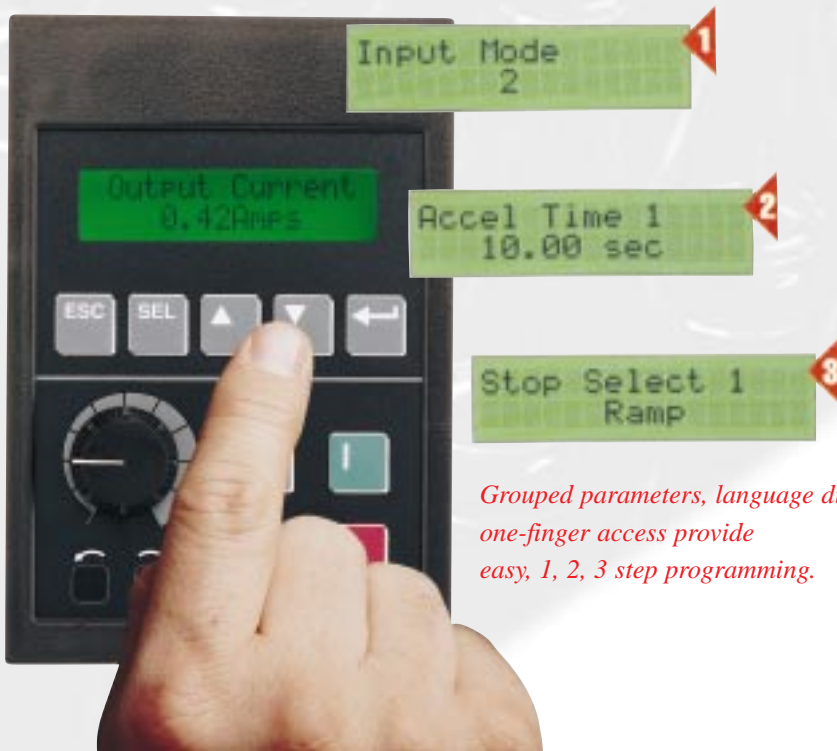

Grouped parameters, language display and simple one-finger access provide easy, 1, 2, 3 step programming.

Choice of Operator Interface

Features & Benefits

- *Alphanumeric display – no decoding*
- *Group parameters – easy look up*
- *Common design – minimum parts for all Allen-Bradley drive products*
- *Simplicity of start-up*
 - Start – no more than 5 parameters*
 - Run – no more than 6 parameters*
 - Stop – no more than 3 parameters*
- *Ability to upload/download parameters from drive to drive, greatly simplifying start-up*



Special Advanced Graphic Programming Terminal (GPT)

- *Advanced Parameter Programming*
- *Full numeric keypad*
- *Parameter upload/download*
- *40-character by 8-line backlit LCD display*

Profit from Better Performance

Speed Regulation

Most AC drives let you control motor speed. The 1336 PLUS AC drive gives you more by combining high performance features with multiple device communication schemes. The result is a more responsive drive/motor combination that optimizes application performance

- Along with standard Frequency Regulation of 0.1% of setpoint, which is useful for synchronous motor applications, the 1336 PLUS provides a variety of programmable speed regulation options.
- Slip Compensation with tumble gain offers 0.5% performance by accurately monitoring motor current and compensating for speed loss due to increased motor slip. For applications requiring load sharing between motors, Negative Slip Compensation or "Droop" is also offered.
- Encoder Feedback provides closed loop speed regulation of 0.1%. The response is based on recovery time, not frequency, and is independent of load inertia. The active speed loop scheme provides smooth response and minimizes overshoot or undershoot under dynamic load conditions.

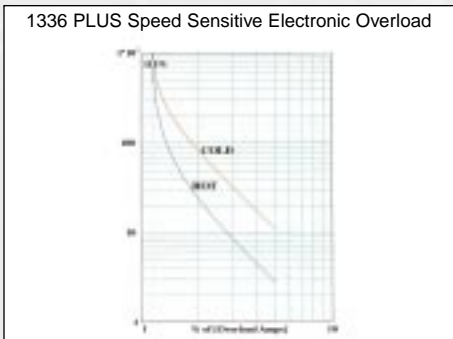
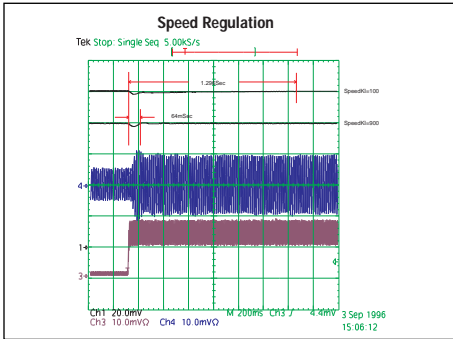

Speed-Sensitive Electronic Overload

is designed to protect motors from extended overloading by simulating the I²t trip curve of a standard UL Class 10 thermal overload. But the I²t function provides even more protection by increasing its sensitivity to tripping when drive output frequency is low. Since the motor is at a lower speed, less cooling exists and a quicker trip time provides more accurate protection.

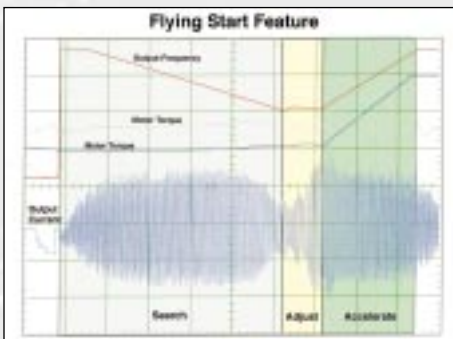

Flying Start

provides the 1336 PLUS with the ability to start into a spinning motor by recognizing the motor's direction and speed. By matching the drive output to the spinning motor, the 1336 PLUS can smoothly pick up the spinning motor and continue operation according to the process commands.

When Allen-Bradley Manufactures Your Drive Package...

You Can Count On...

Enclosure Sizing

- Designed to meet NEMA standards
- Sufficient heat dissipation

Factory Wired Options

- Proper wire type and size
- Neatly bundled and routed
- Separated power, control and signal

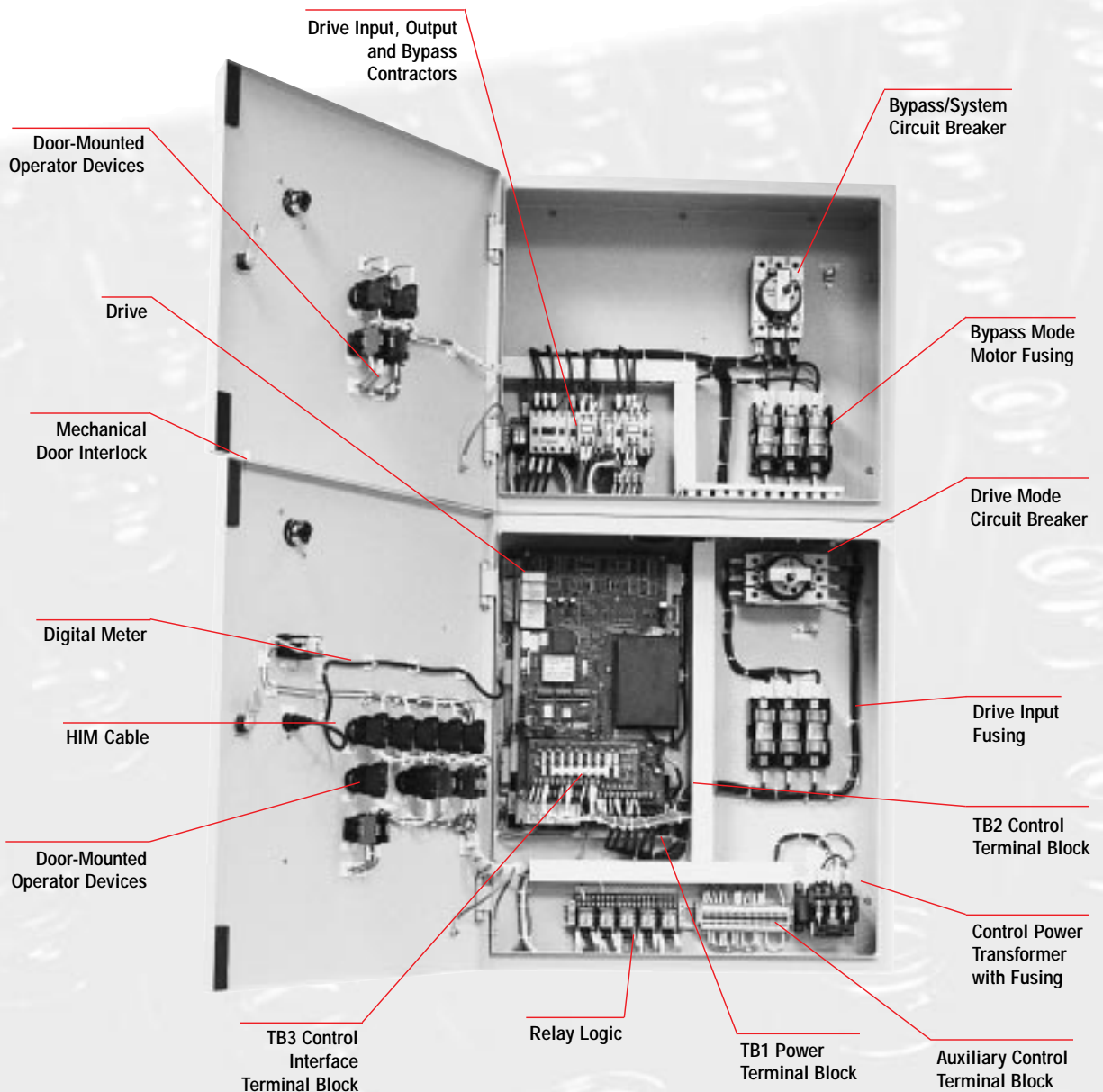

30 HP 460V AC NEMA Type 1 Configured Drive with
Expanded Option Enclosure

Consistent Panel Component Layouts

- Proper electrical/mechanical clearances
- Lower cost customer interface wiring
- Faster troubleshooting

Provision for Mounting

- Slotted tabs on small drives
- Floorplate holes on larger drives

Consistent Door Layouts

- Easier operator training
- Functionality is consistent
- Aesthetically/ergonomically pleasing

Provision for Lifting

- Slotted chassis holes on small drives
- Removable lifting bar on large drives

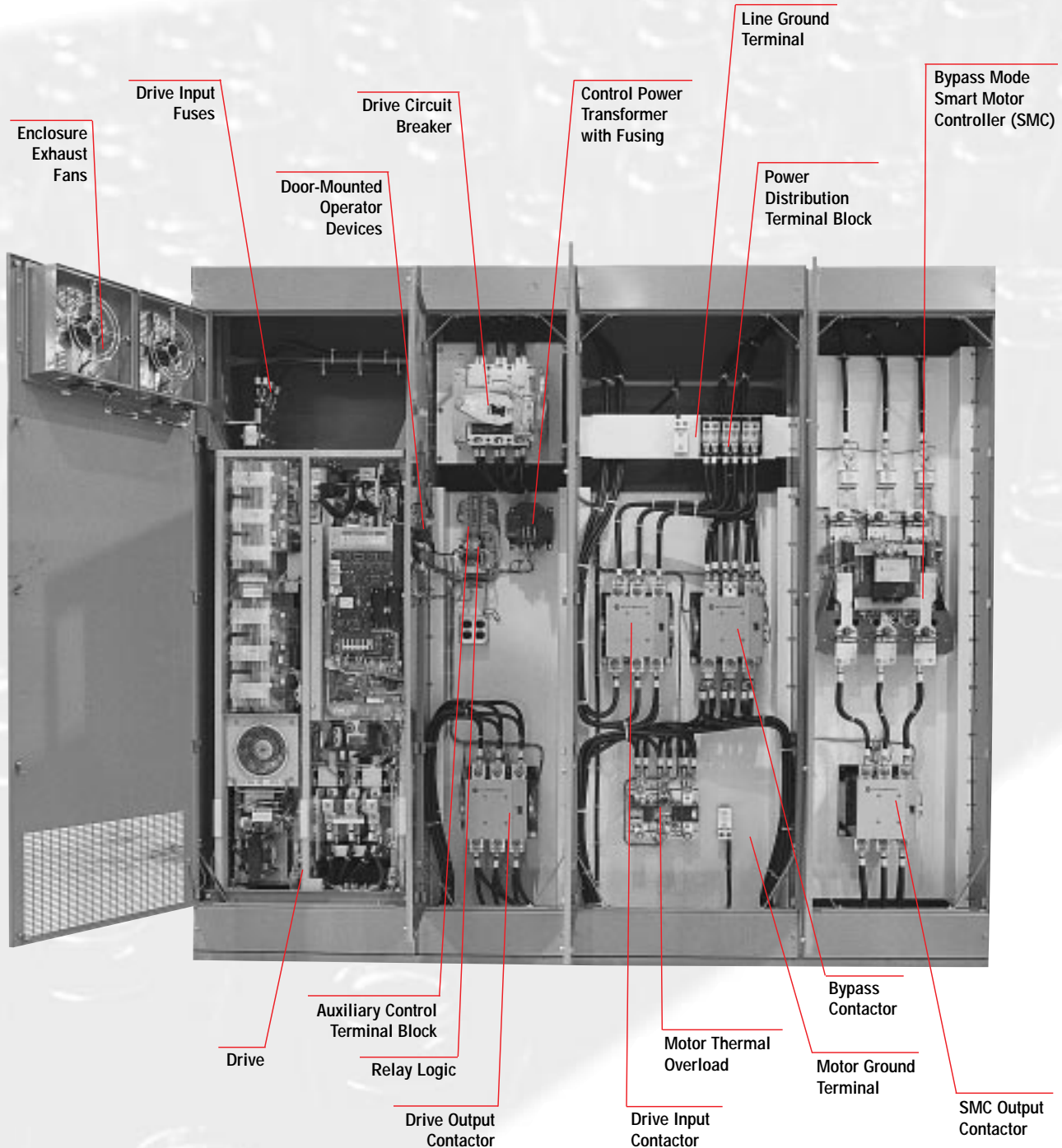

500 HP 460V AC NEMA Type 1 Configured Drive with SMC Style Bypass

Packaging Options



*200 HP 1336 PLUS NEMA Type 1
Configured Drive with Option Bay.
(See page 3 for internal view.)*



*500 HP 1336 PLUS NEMA Type 1
Configured Drive with SMC Style Bypass.
(See page 7 for internal view.)*



*30 HP NEMA Type 1
Configured Drive with
Add-On Bypass Enclosure.*



*300 HP Custom NEMA Type 12
Drive with Dual Air
Conditioners for Internally
Mounted Drive Heatsink.*



*60 HP 1336 PLUS Nema
Type 1 Commercial Drive.
(For more information on
this separate program see
Product Data Publication
1336 PLUS - 1.5.)*

The Allen-Bradley 1336 family of AC drives offers advanced electronics technology. From the IGBT-based Power Structure to the 16-bit microprocessor, the 1336 variable frequency drives offer opportunities for increased productivity and energy savings. The 1336 PLUS drive is designed to be a major influence in assuring the quality of today's environment. The energy-efficient drives dynamically control the speed and torque of standard AC motors.

Pumps, Fans and Blowers

Fresh water pumping systems, wastewater treatment plants, filter presses and continuously variable load applications demand accurate control. Allen-Bradley AC drives provide more precise control of air flow in a variety of centrifugal systems while offering significant energy savings. In addition, integral PI process control increases flexibility and reduces the need for additional components. Whether your applications are easy or tough, the 1336 PLUS offers the simple solution.

Material Handling

Varying load requirements occurring with material handling type equipment, such as packaging or bottling lines, are easily handled with the 1336 PLUS drive. Features such as S-curve acceleration profiles, multiple stop modes and preset speeds provide application flexibility to meet most customer applications from the simplest starting requirements to the toughest speed control.

Extruders and Mixers

Extruders and similar type applications have the following characteristics and requirements:

- Constant torque operation which requires rated torque from zero to full speed.
- All friction, little or no inertia – no dynamic braking requirement.
- Starting may require more than rated torque.
- Fairly constant average load.

Mills, pelletizers and digesters may have substantial shock loads. Mixers and metering pumps require precise speed control and tracking an external frequency reference. Mills, grinders, digesters and pelletizers may be required to follow analog process signals.

Material in (or downstream from) melters and extruders can solidify if the machine stops. The 1336 PLUS provides proactive current limit operation (preferred over simple current trip.)

efesotomasyon.com

Special Applications

The 1336 PLUS Configured Drive can be applied to specialized applications with cyclic loads, high inertia or continuous regenerative requirements. With the myriad of available drive configurations, the 1336 PLUS handles many specialized applications with ease.

Applications



Pumps, Fans and Blowers

- HVAC Systems
- VOC Incinerators
- Paint Booths
- Fresh Air Supply
- Recirculation Systems
- WAS/RAS Pumps
- Induced Draft Fans
- Forced Draft Fans



Material Handling

- Bottling Lines
- Oven Conveyors
- Chain Conveyors
- Belt Conveyors
- Shuttle Conveyors
- Packaging Lines
- Fiber Lines
- Runout Tables



Extruders and Mixers

- Mixers
- Extruders
- Mills
- Grinders
- Pelletizers
- Digesters
- Melters
- Metering Pumps



Special Applications

- Traverse Winders
- Finish Rolls
- Stamping Presses
- Floculators
- Debarkers
- Chip-n-Saw
- Lime Kilns
- Chip Screw Feeders

Communication Flexibility

Commonality of design across the entire range, coupled with identical control interface functions, identical device communications, training and service, provide you with a tremendous advantage in your system control needs. Other Allen-Bradley products such as PLC®, SLC™, PanelView™ and DriveTools™ will easily interface to these drives.

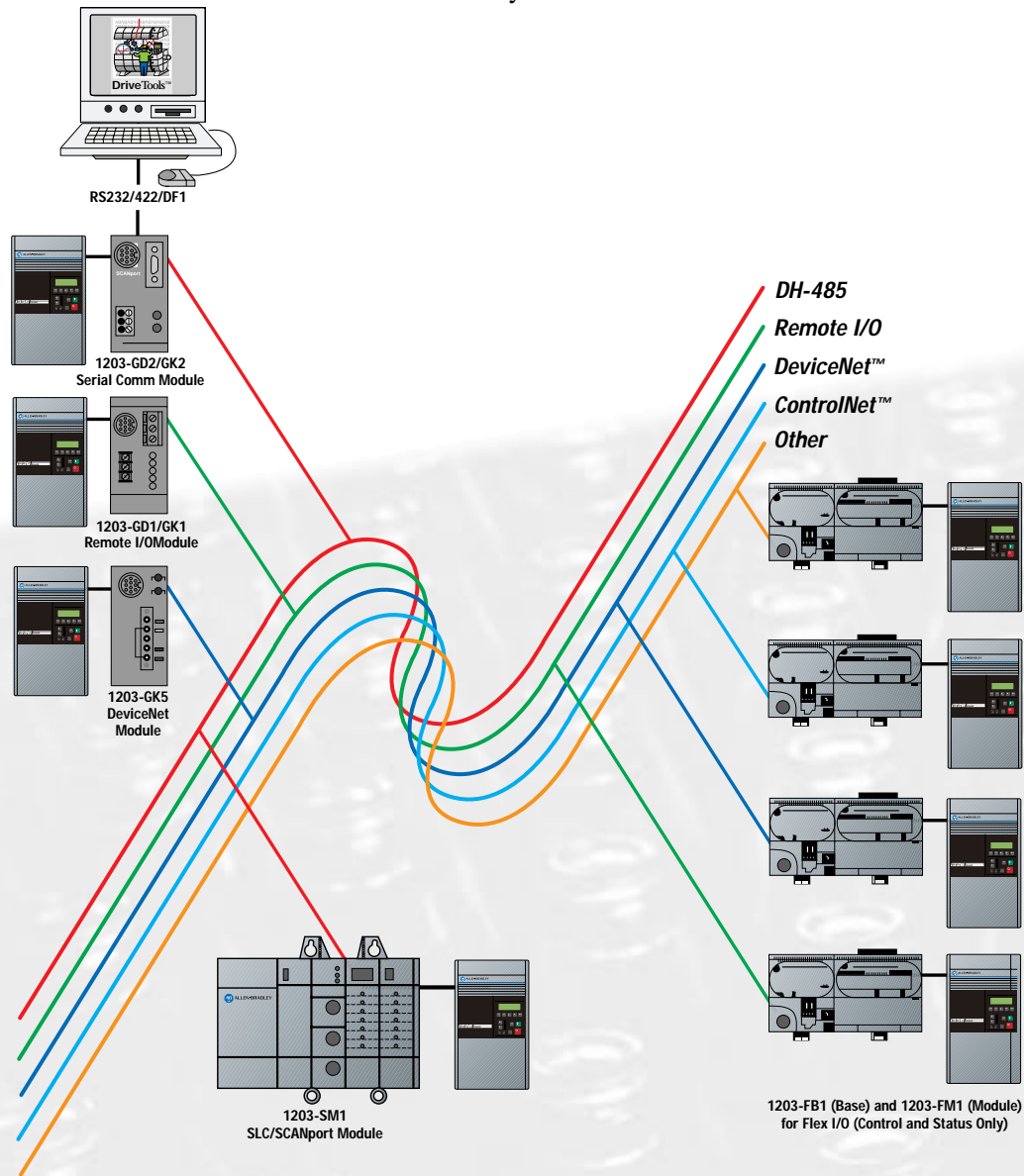

As the move towards factory automation continues, it is becoming increasingly important for all products to be capable of communicating critical information. Gone are the days when the only things required are a Start/Stop input and a fault contact output. Allen-Bradley recognizes this trend and has adopted a unique strategy to enable you to accommodate a wide range of communication options.

The interfaces included in our communication strategy address the various network requirements:

- *The Serial Comm. module's primary focus is on programming and serial data communication (information).*
- *Remote I/O is best suited for control applications, but has been used for collection of data.*
- *DeviceNet is primarily a control and device interconnection network.*
- *Flex™ I/O to SCANport™ communication module provides a unique interface for connecting a SCANport product to a variety of networks.*
- *SLC™ to SCANport offers optimum performance for SLC Programmable Controllers.*
- *The DriveTools™ Suite, Microsoft® Windows™-based product has easy-to-use menus, dialogs and graphic displays to allow for programming, monitoring and troubleshooting drives and drive systems from a personal computer.*

Keeping Your Processes Running is What Drives Our Commitment to Quality

All new drive product designs are a joint effort that involves Development Engineering, Quality Management, Manufacturing Engineering, Component Engineering, Product Marketing and quality personnel from all departments. This detailed process known as industrialization ensures that every aspect of a product is strongly considered before the product is actually built. Each new drive design is put through scores of rigid, demanding Qualification Tests and a comprehensive set of performance tests. Assembled components are qualified and pretested before being shipped to our manufacturing facilities. Printed circuit boards are electrically tested and environmentally stressed under power before they are assembled into a drive. At the end of the assembly line, each drive is put through two complete function tests, including a fully rated dynamometer test that includes load, speed and power cycling to bring the drive to fully rated operating temperature. As a final test, a 100% system test is performed prior to the drive being packaged and shipped. This stringent testing schedule assures that every portion (output, input, feedback, logic, power and I/O) of every drive proves its reliability before it becomes part of our customer's process.

Our commitment to quality is driven by our commitment to enhancing our customers' success worldwide with products, services and responsiveness that set industry standards for quality and value.

Quality Drives, Quality Driven

There's a reason why the word "Quality" has been part of the Allen-Bradley identity for more than 90 years. We understand the direct relationship between our product quality and your productivity, and we let that understanding guide everything we do.



Our drives headquarters and world class manufacturing center provide drives development, systems engineering, manufacturing, functional testing, customer training and support under one roof.

Quality



Configured to Meet Your Needs



Power-Matched Motors

Allen-Bradley motors are available with a wide selection of types, sizes and enclosures to cost-effectively meet your variable-speed performance needs.

Use An Allen-Bradley Power-Matched Motor with 1336 PLUS Configured Drives

Power-Matched motors provide improved operating efficiency. However, the complete answer goes further than this. Since the motor voltage/current waveshape is determined **by both the drive and motor**, optimum performance is achieved when the motor and drive are matched to each other. The Allen-Bradley variable speed motor is Power-Matched in its electrical design to the 1336 PLUS. This improves performance and helps provide longer life and cooler motor operation.

Not Every Motor is Optimized for Use on Adjustable Frequency Drives

Inverter rated motors available on the market today will operate satisfactorily with a 1336 PLUS drive. However, using an Allen-Bradley Power-Matched package of drive and motor removes the guesswork and helps provide a superior solution from a single source you can trust.

High Performance Motors

Allen-Bradley high performance motors are designed for open or closed loop applications which require fast and accurate response to maintain programmed speed values. They're also ideal for most applications which require full motor torque down to zero speed.



Definite Purpose Motors

A wide selection of motor designs is also available to help meet specific industry or application requirements. In addition, all general purpose and high performance motors can be modified to help meet specific performance, ambient environment and mounting needs. DC retrofit applications often require this type of modification.



Wide Range of Choices

No matter how you use variable-speed drives and motors, Allen-Bradley offers a combination that can cost-effectively meet your near-term fast start-up and performance requirements, with long-term durability and low maintenance needs. In addition to a wide selection of drive types, there are thousands of motor choices available with the performance, feedback, enclosure and ambient protection capabilities to help meet your simplest or most demanding application requirements.



30 HP NEMA TYPE 1 CONFIGURED DRIVE WITH OPTION ENCLOSURE

1336 PLUS CONFIGURED DRIVE PRODUCT DESCRIPTION	16
1336 PLUS CONFIGURED DRIVE SPECIFICATIONS	18
1336 PLUS CONFIGURED DRIVE FUNCTION DESCRIPTION	22
1336 PLUS CONFIGURED DRIVE PARAMETER AND FAULT DESCRIPTIONS	28
1336 PLUS CONFIGURED DRIVE OPTION DESCRIPTION	31
1336 PLUS CONFIGURED DRIVE PRE-INSTALLATION DATA	41
Enclosures	41
Material Specifications	42
Enclosure Dimensions	43
IP20 (NEMA Type 1) 0.37-45 kW (0.5-60 HP/1.1-77 A)	43
IP54 (NEMA Type 12) 0.37-45 kW (0.5-60 HP/1.1-77 A)	44
IP20 (NEMA Type 1) & IP54 (NEMA Type 12) 45-187 kW (60-250 HP/85-180 A)	45
IP20 (NEMA Type 1) & IP54 (NEMA Type 12) 224-448 kW (300-600HP/360-670 A)	46
IP20 (NEMA Type 1) & IP54 (NEMA Type 12) 45-187 kW (300-600HP/360-670 A)	47
Panel Layouts — 230/460V 0.37-3.7 kW (0.5-5 HP)	48
Panel Layouts — 230V 5.5-11 kW (7.5-15 HP)	50
460V 5.5-22 kW (7.5-30 HP)	
575V 5.5-15 kW (7.5-20 HP)	
Panel Layouts — 230V 15-22 kW (20-30 HP)	53
460V 30-45 kW (40-60 HP/59-77 A)	
575V 18.5-45 kW (25-60 HP)	
Panel Layouts — 460V 45-112 kW (60-150 HP/85-180 A)	55
575V 56-112 kW (75-150 HP)	
Panel Layouts — 460V 112-187 kW (150-250 HP)	56
575V 112-149 kW (150-200 HP)	
Panel Layouts — 460V 112-187 kW (150-250 HP)	57
575V 112-149 kW (150-200 HP)	
Panel Layouts — 460V 400-805 kW (300-600 HP)	58
575V 400-805 kW (300-600 HP)	
Mounting Requirements	59
Input Conditioning	59
AC Supply Source	60
Drive Input Fusing	61
Power Wiring — Drive Terminal Block TB1	62
External Signal Wiring — TE	63
Control and Signal Wiring — Drive Terminal Block TB2	63
Control Interface Wiring — Drive Terminal Block TB3	65
Motor Power Wiring	66
Installation Cooling Requirements and Derating Guidelines	69
Ambient Temperature/Carrier Frequency	70
Altitude	75
High Input Voltage	75
1336 PLUS CONFIGURED DRIVE SELECTION GUIDE	76
Catalog Number Definition	76
230V Constant and Variable Torque Drives and Enclosures	78
460V Constant Torque Drives and Enclosures	78
460V Variable Torque Drives and Enclosures	79
575V Constant and Variable Torque Drives and Enclosures	79
Motor Thermal Overload Relay Selection	80
Heater Element Selection	81
Option Kits Not Factory Mounted	82
Option Kits Not Factory Installed	83
Option Selection Reference Chart	85
1336 PLUS CONFIGURED DRIVE ORDER DOCUMENTATION SAMPLE	87

The 1336 PLUS Drive

The heart of every configured drive package is a 1336 PLUS variable frequency controller.

The 1336 PLUS is a microprocessor based adjustable frequency AC drive. Its advanced design provides exceptional reliability when controlling 3-phase motors, producing a 3-phase, PWM,

adjustable frequency & voltage output to control motor speed & torque. The output can be tuned to provide optimum performance for virtually any load conditions. Selectable **SENSORLESS VECTOR** or V/Hz operation provides outstanding motor control.

The 1336 PLUS Configured Drive

The packaged solution to your application needs.

The configured drives program provides 1336 PLUS drives packaged with a much larger offering of factory mounted options than is normally available.

Ratings are provided for 0.37-22 kW (0.5-30 HP) at 230, 0.37-448 kW (0.5-600 HP) at 460, or 5.5-448 kW (7.5-600 HP) at 575V. Separate constant torque and variable torque ratings are available for 460V applications.

Simplicity

Design and programming simplicity is evident in:

- **Common components and assembly parts** used wherever possible to reduce the need to stock a multitude of parts.
- **Easy to program parameters** that are organized in a group and parameter structure for quick access to related functions.
- **Common assembly parts** that reduces the need to stock a multitude of parts.

- **An easy to read Supertwist Liquid Crystal Display** gives 2 lines of 16 characters each for easy “one finger” programming and drive monitoring.
- **Serial communications** that provide easy integration and access to peripheral equipment — Fully compatible with all Allen-Bradley PLC®, SLC™ or SCANport™ equipment.
- **Common options** that are used throughout the entire family of Drives.

Standardization

Pre-defined to reduce cost and time.

By using pre-defined, and in most cases pre-engineered options, standardization

provides consistency of product offering, resulting in reduced costs and shorter delivery time.

Diagnostics

Real time preventative maintenance coupled with customized status and fault reporting.

Depending upon your particular drive configuration, status and fault conditions can be reported through the Human Interface Module or through the SCANport Communications Port. Fault diagnostic routines are started each time the 1336 PLUS is powered up.

Throughout the entire run sequence, the drive will continue to look for potential

fault conditions. To allow real-time preventive maintenance, drive output current and control conditions can be selectively monitored while the drive is running. The operator is made aware of alarm conditions such as current limit and bus voltage status before the drive reaches a fault level. **Should a fault occur, plain language diagnostic messages help identify and isolate the problem** allowing personnel to take quick, corrective action.

efesotomasyon.com

Features

Protective

- Detection and Trip:
 - Undervoltage
 - Overvoltage
 - Drive Overcurrent
 - Overtemperature
 - External Signal
 - Drive Output Short
 - Ground Fault
- Overcurrent Stall
- Overvoltage Stall
- Six Drive Alarms

Special Function

- Auto Economizer
- Process PI Controller
- Traverse Function
- Selectable Fault Reset & Run
- Auto Restart on Power Up
- Speed Sensitive Electronic Overload

Operational

-  **SENSORLESS VECTOR** Control
- Selectable Volts/Hertz Mode

Programmable

- Dual Accel/Decel Profiles
- Three Skip Frequencies
- DC Injection Braking
- Dynamic Braking
- Slip Compensation
- Negative Slip Compensation (Droop)
- S Curve Accel/Decel Profile
- Line Loss Restart Mode
- Proactive Current Limit
- Last Four Event Fault Memory
- Flying Start
- Seven Preset Speeds

I/O Interface

- Control Output Contacts
 - (2) Form A (N.O.)
 - (2) Form C (N.O. - N.C.)
 Programmable to 17 different drive variables.
- 0-10V DC Analog Input with programmable scale, offset, invert and square root.
- 4-20 mA Analog Input with programmable gain, offset, invert, square root and signal loss reverse.
- Selectable 0-10V DC/0-20 mA Analog Output with programmable scale, offset and invert.
- Pulse Train Input
- Encoder Feedback Closed Loop Speed Control

Performance

Powerful algorithms provide unparalleled  performance.

Starting acceleration and running torque in excess of 250% combined with a constant torque speed range of 120:1 allow the 1336 PLUS to handle the tough applications other drives can't.

Packaging

Planer Construction of the 1336 PLUS drive eliminates most internal cables and connectors.

Laminar Bus Design of the 1336 PLUS drive reduces internal inductance, thereby reducing snubber losses and improving IGBT performance.

Removable Common Human Interface Module provides simplicity of programming and flexibility of operation.

Thermal Dissipation Management. Design and extensive infra-red testing minimizes hot spots to maximize reliability.

Modular enclosure design to accommodate a wide variety of drive ratings and option combinations.

IP 20, 65 & 54 (NEMA Type 1, 4 & 12) configurations accommodated with "heat sink through the back" design.

Electrical

IGBT's (Insulated Gate Bipolar Transistors)

- Quiet motor operation through programmable carrier frequency.
- Third Generation devices — Reduced switching and conduction losses.
- Used on complete line 0.37-448 kW (0.5-600 HP).

Dynamic Current Control

- Multiple sensors.

- Exceptional torque production through  Control.

- Proactive current limit control — Reduces trips.
- Ability to start low inductance motors.

Isolated Power and Logic eliminates noise to provide reliable and stable operation.

DC Cooling Fan on many ratings eliminates the need for a transformer and voltage

tapping; accommodates global usage.

Internal Logic Supply from DC Bus does not require separate control power wiring, improved ride-thru capability.

Communications. Built-in serial bus provides ease of integration to a wide variety of protocols.

Protection Specifications

	230V Drive	460V Drive	575V Drive
AC Input Overvoltage Trip	285V AC	570V AC	690V AC
AC Input Undervoltage Trip	138V AC	280V AC	343V AC
Bus Overvoltage Trip	405V DC	810V DC	975V DC
Bus Undervoltage Trip	200V DC	400V DC	498V DC
Heat Sink Thermistor	Monitored by microprocessor.		
Drive Overcurrent Trip	Software Current Limit: 20 to 160% of VT rated current. Hardware Current Limit: 180 to 250% of VT rated current (dependent on drive rating). Instantaneous Current Limit: 220 to 300% of VT rated current (dependent on drive rating).		
Line transients	Up to 6000 volts peak per IEEE C62.41-1991.		
Control Logic Noise Immunity	Showering arc transients up to 1500 volts peak.		
Power Ride-Thru	15 milliseconds at full load — refer to page 24.		
Logic Control Ride-Thru	0.5 seconds minimum, 2 seconds typical — refer to page 24.		
Ground Fault Trip	Phase-to-Ground on Drive Output.		
Short Circuit Trip	Phase-to-Phase on Drive Output.		

Environmental Specifications

Altitude	1000 m (3300 ft) maximum without derating. — refer to the Drive Derating Guidelines on pages 69-75 —		
Ambient Operating Temperature	0 to 40°C (32 to 104°F). — refer to the Drive Derating Guidelines on pages 69-75 —		
Storage Temperature (all constructions)	– 40 to 70°C (– 40 to 158°F).		
Relative Humidity	5 to 95% non-condensing.		
Shock	15G peak for 11 ms duration (±1.0 ms).		
Vibration	0.006 inches (0.152 mm) displacement, 1G peak.		
Agency Certification	U.L. Listed ¹ CSA Certified ¹		

¹ Not all options and packaging styles qualify.

Control Specifications

Method	Sine coded PWM with programmable carrier frequency. Ratings apply to all drives. A Frame 2-10 kHz, Drive Rating based on 4 kHz. B Frame 2-8 kHz, Drive Rating based on 4 kHz. C & D Frame 2-6 kHz, Drive Rating based on 4 kHz. E Frame & Up 2-6 kHz, Drive Rating based on 2 kHz. — refer to the Drive Derating Guidelines on pages 69-75 —	
Output Voltage Range	0 to rated voltage.	
Output Frequency Range	0 to 400Hz.	
Frequency Accuracy	Analog Input:	Within ±0.4% of maximum output frequency.
	Digital Input:	Within ±0.01% of set output frequency.
Volts per Hertz Ratio	Fully programmable.	
DC Boost	No Boost, Auto Mode (8 settings with programmable Run Boost reduction), Full Custom, Fan Mode (2), or Fixed Mode (with independent Accel and Run Boosts).	
Accel/Decel	Two independently programmable accel and decel times. Each time may be programmed from 0 to 3600 seconds ¹ in 0.01 second increments ² .	
Intermittent Overload	Constant Torque: 150% of rated output for 1 minute. Variable Torque: 115% of rated output for 1 minute.	
Current Limit Capability	Proactive Current Limit programmable from 20 to 160% of rated output current. Independently programmable proportional and integral gain.	
Inverse Time Overload Capability	Class 10 protection with speed sensitive response. Investigated by U.L. to comply with N.E.C. Article 430. U.L. file E59272, volume 4/6.	
Selectable Motor Control	 with full tuning. Standard V/Hz with full custom capability.	

Electrical Specifications

Input Data	Voltage Tolerance:	-10% of Minimum, +10% of Maximum.
	Frequency Tolerance:	48-62 Hz.
	Number of Phases:	3 — 100% for All Drives. 1 — 50% for 0.37-11 kW (0.5-15 HP) at 230V 0.37-22 kW (0.5-30 HP) at 460V 0.37-15 kW (0.5-20 HP) at 575V — refer to the Drive Derating Guidelines on pages 69-75 —
Displacement Power Factor	A1 - A3 Frame:	0.80 (standard), 0.95 with Optional Inductor.
	A4 Frame & Up:	0.95.
Efficiency	97.5% at rated amps, nominal line volts.	
Maximum Short Circuit Drive Package Current Rating	200,000A rms symmetrical, 600 volts, using standard input fusing on 0.5-250 HP drives. 300,000A rms symmetrical, 600 volts, using standard input fusing on 300-600 HP drives.	

¹ 600 seconds with Firmware Versions before 4.01.

² 0.1 second increments using a HIM or 0.01 with serial communicators.

Display Specifications

Local Programming and Display Panel	<p>Backlit Supertwist LCD display. 2 lines, 16 characters each. Multi-lingual display of status, faults and programming. Process Display — 2 lines, any 2 parameters, scalable with user text. Selectable “power up” display.</p>
-------------------------------------	---

Load Specifications

Requirements	A balanced 3-phase inductive motor load is typical. Drive power rating is based on a typical NEMA Design B, 4 or 6 pole motor. Other motor loads may require application assistance.
--------------	--

Speed Reference Inputs

Digital Input Specifications	<p>Frequency Resolution: Maximum frequency programmed divided by 32767 (15 bits). 60 Hz — 0.0018 Hz. 100 Hz — 0.003 Hz. 400 Hz — 0.012 Hz.</p>
------------------------------	--

Analog Input Specifications	<p>4-20mA, Non-Isolated (optional isolators are available). Resolution: 0.103% of Programmed Max Frequency. Input Impedance: 250 Ohms.</p> <p>0-10V DC, Non-Isolated (optional isolators are available). Resolution: 0.107% of Programmed Max Frequency. Input Impedance: 100k Ohms.</p> <p>Remote Pot Resolution: 0.158% of Programmed Max Frequency. 10k Ohm Pot Required.</p> <p>Local Pot (HIM) Resolution: 0.100% of Programmed Max Frequency.</p>
-----------------------------	--

Pulse Input Specifications	<p>Pulse input signal must be an externally powered square-wave pulse at a 5V TTL logic level. Circuits in the low state must generate a voltage between 0.0 and 0.4V DC. Circuits in the high state must generate a voltage between 4.0 and 5.5V DC at 16mA. Maximum Input Frequency — 125 kHz. Scale factor [Pulse/Enc Scale] must be set.</p> <p>Important: Pulse inputs (TB2, terminal 7 & 8) cannot be used if encoder inputs (TB3, terminal 31-36) are being used.</p>
----------------------------	---

Control Outputs

Contact Outputs ¹	<p>115V AC, 30V DC — 5.0 Amp Resistive — 2.0 Amp Inductive. (2) Form C Contacts. (2) Form A Contacts. (1) Form C Alarm Contact.</p> <p>All contacts are fully programmable for closure relative to 17 different drive variables selected through the “CR1-4 Out Select” parameters.</p>
------------------------------	--

Analog Outputs	<p>(1) Selectable. Either 0-10V DC or 0-20 mA fully configurable for scale, offset and invert. Programmable proportional to 13 different drive variables selected through the Analog Out Select parameter. Typical accuracy is $\pm 1.2\%$.</p>
----------------	--

¹ Not all of these contacts will be available for customer use if any of the following options are specified: auto bypass, elapsed time meter, motor heater, enclosure heater, drive alarm pilot light or at speed pilot light.

Input/Output Ratings

Requirements

Each 1336 PLUS Drive has constant and variable torque capabilities. The listings below provide input and output current. ¹

230V					
HP	Cat No.	Constant Torque			
		Input kVA	Input Amps	Output kVA	Output Amps
0.5	AF05C	1.1	2.8	0.9	2.3
0.75	AF07C	1.4	3.5	1.2	3.0
1	AF10C	2.2	5.4	1.8	4.5
1.5	AF15C	2.9	7.3	2.4	6.0
2	AF20C	3.9	9.7	3.2	8.0
3	AF30C	5.7	14.3	4.8	12
5	AF50C	8.5	21.3	7.2	18
7.5	A007C	10-12	28	11	27
10	A010C	12-14	35	14	34
15	A015C	17-20	49	19	48
20	A020C	22-26	63	26	65
25	A025C	26-31	75	31	77
30	A030C	27-33	79	32	80
40	A040C	41-49	119	48	120
50	A050C	52-62	149	60	150
60	A060C	62-74	178	72	180
75	A075C	82-99	238	96	240
100	A100C	100-120	289	116	291
125	A125C	112-134	322	129	325

460V											
HP	Cat No.	Constant Torque				HP	Cat No.	Variable Torque			
		Input kVA	Input Amps	Output kVA	Output Amps			Input kVA	Input Amps	Output kVA	Output Amps
0.5	BF05C	0.9-1.1	1.3	0.9	1.1	0.5	BF05V	0.9-1.1	1.4	1	1.2
0.75	BF07C	1.3-1.6	2	1.3	1.6	0.75	BF07V	1.4-1.7	2.1	1.4	1.7
1	BF10C	1.6-2	2.8	1.6	2.1	1	BF10V	1.8-2.2	2.8	1.8	2.3
1.5	BF15C	2.2-2.6	3.3	2.2	2.8	1.5	BF15V	2.3-2.8	3.5	2.4	3
2	BF20C	3.0-3.7	4.6	3	3.8	2	BF20V	3.2-3.8	4.8	3.2	4
3	BF30C	4.2-5.1	6.4	4.2	5.3	3	BF30V	4.7-5.7	7.2	4.8	6
5	BF50C	6.6-8	10	6.7	8.4	5	BF50V	7.0-8.5	10.7	7.2	9
7.5	B007C	8-11	13	10	12.5	7.5	BX007V	8-11	13	10	12.5
7.5	BF75C	9.5-11.6	14.5	11.2	14	7.5	BF75V	12.2-14.7	18.5	13.9	17.5
10	B010C	11-14	17	13	16.1	10	B007V	9-12	14	11	14
10	BF100C	12.2-14.7	18.5	13.9	17.5	10	BF100V	17.1-20.7	26	19.9	25
15	B015C	16-21	25	19	24.2	15	B010V	14-18	22	17	21
20	B020C	21-26	32	25	31	20	B015V	18-23	28	22	27
25	B025C	26-33	40	31	39	25	B020V	23-29	35	27	34
30	B030C	30-38	46	36	45	30	B030V	32-41	49	38	48
40	BX040C	40-50	61	47	59	40	BX040V	40-50	61	47	59
50	B050C	48-60	73	60	75	50	B040V	41-52	63	52	65
60 ²	BX060C	62	75	61	77	60	BX060V	62	75	61	77
60	B060C	54-68	82	68	85						
75	B075C	69-87	105	84	106	75	B060V	61-77	93	76	96
100	B100C	90-114	137	110	138	100	B075V	78-99	119	96	120
125	B125C	113-143	172	138	173	125	B100V	98-124	149	120	150
150	BX150C	148	178	143	180	150	B125V	117-148	178	143	180
150	B150C	130-164	197	159	199						
200	B200C	172-217	261	210	263	200	B150V	157-198	238	191	240
250	B250C	212-268	322	259	325	250	B200V	191-241	290	233	292
		—	—	—	—	250	B250V	212-268	322	259	325
250	BP250C	212-268	322	259	325						
300	B300C	228-288	347	279	360	300	BX250V	228-288	347	279	360
300	BP300C	235-297	357	287	360	300	BP250V	235-297	357	287	360
350	B350C	261-330	397	319	425	350	B300V	261-330	397	319	425
350	BP350C	277-350	421	339	425	350	BP300V	277-350	421	339	425
400	B400C	294-371	446	359	475	400	B350V	294-371	446	359	475
400	BP400C	310-392	471	378	475	400	BP350V	310-392	471	378	475
450	B450C	326-412	496	398	525	450	B400V	326-412	496	398	525
450	BP450C	347-438	527	424	532	450	BP400V	347-438	527	424	532
500	B500C	372-470	565	454	590	500	B450V	372-470	565	454	590
600	B600C	437-552	664	534	670	600	B500V	437-552	664	534	670

575V					
HP	Cat No.	Constant Torque			
		Input kVA	Input Amps	Output kVA	Output Amps
1	CF10C	2.1-2.5	2.4	2.1	2
2	CF20C	4.2-5	4.8	4.2	4
3	CF30C	6.2-7.5	7.2	6.2	6
5	CF50C	8.3-10	9.6	8.3	8
7.5	C007C	9-11	10	10	10
10	C010C	11-13	12	12	12
15	C015C	17-20	19	19	19
20	C020C	21-26	25	24	24
25	C025C	27-32	31	30	30
30	C030C	31-37	36	35	35
40	C040C	38-45	44	45	45
50	C050C	48-57	55	57	57
60	C060C	52-62	60	62	62
75	C075C	73-88	84	85	85
100	C100C	94-112	108	109	109
125	C125C	118-142	137	137	138
150	C150C	144-173	167	167	168
200	C200C	216-260	250	252	252
250	C250C	244-293	282	283	384
300	CX300C	256-307	295	297	300
300	C300C	258-309	297	299	300
350	C350C	301-361	347	349	350
400	C400C	343-412	397	398	400
450	C450C	386-464	446	448	450
500	C500C	429-515	496	498	500
600	C600C	515-618	595	598	600

efesotomasyon.com

¹ Drive ratings are at nominal values. Refer to the Drive Derating Guidelines on pages 69-75.

² 480V only.

Sensorless Vector Motor Control

New vector control adds exceptional torque performance to the 1336 PLUS. This powerful algorithm provides the following performance enhancements.



- Outstanding low speed torque at speeds as low as 15 RPM, providing a 120:1 constant torque speed range.
- Improved acceleration control can provide up to 250% breakaway/acceleration torque to move the toughest loads with ease.
- Solid “out-of-the-box” performance. Enhanced performance can be gained by programming the setup parameters with actual motor nameplate values. Optimum results can be achieved by programming the actual amps required to generate no load flux and the actual voltage needed for IR compensation. If these values are not known, setup procedures can determine the exact values.
- A fast accel mode is provided. Disabling the Adaptive Current Limit feature provides the lowest possible acceleration time for low inertia applications.
- A fast flux-up mode is programmable to aid in acceleration with large motors.
- Selectable Volts/Hertz modes are also available. When selected, they provide full functionality including Start Boost and Run Boost, Boost Slope and “Full Custom” V/Hz operation.

Electronic Motor Overload Protection

Motor I^2t protection is separated from the drive power overload feature. The electronic motor overload operates independently to provide improved Class 10 protection. Operation at full load amps will raise the overload to approximately 70-80% of its trip level. Overloading beyond FLA will move the value towards tripping level (100%) based on I^2t . Trip curves are provided for both hot and cold states. Parameter settings include:

- Overload Amps from the motor nameplate FLA.
- Motor OL Fault parameter to disable the fault condition.
- In addition, Bit 14 (Motor OL Trip) of the Drive Alarm parameter is high (1) any time the existing level of output current will cause an Overload Fault to occur.

The overload feature remains speed sensitive with 3 derating choices:

- Max Derate is used for motors not designed for variable speed.
- Min Derate is used for motors with a 4:1 speed range (not intended for operation below 25% of base speed).
- No Derate is used for variable speed motors with a speed range capability of 10:1 or better.

Overload Patterns

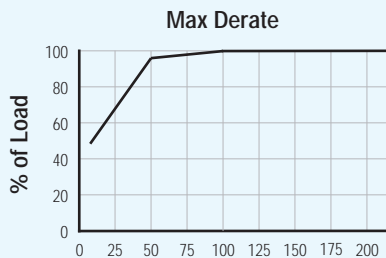
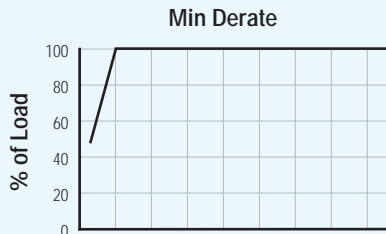
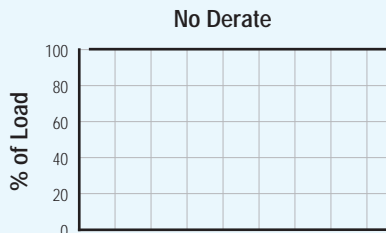

Time to Trip vs. Current (Firmware 4)

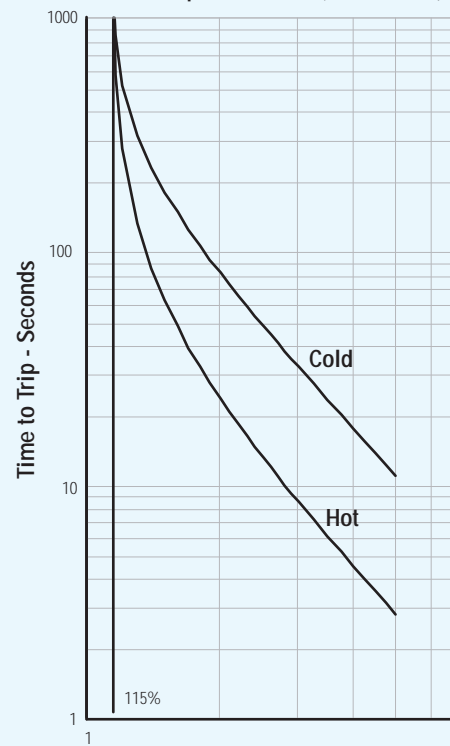

Fixed Accel/Run Boost

Fixed Accel/Run Boost in the 1336 PLUS provides adjustable DC boost settings for both start and run boost. The programmed start boost is applied at starting or anytime the drive is accelerating from low speed, providing the necessary breakaway and acceleration torque. When the drive must run at lower speeds, however, this boost level may cause excessive current. To reduce this current, the drive will automatically apply the lower Run Boost voltage as long as it is not accelerating.

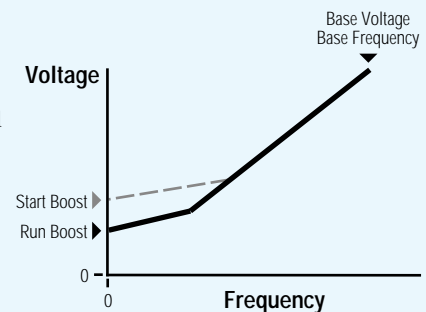

Flying Start

Some applications require that the drive “pick up” a spinning load at its current speed and direction, then accelerate or decelerate to the actual commanded speed and direction. The 1336 PLUS offers a programmable feature called Flying Start. This feature has the ability to determine the speed and direction of a rotating motor and begin its output at that speed. The drive will then bring the motor to the commanded speed. Flying start can be accomplished with or without a motor mounted encoder.

Reset/Run

The 1336 PLUS offers the ability to automatically reset a fault (if the condition that causes the fault is no longer present) and restart. Both the number of reset attempts (0-9) and the time between reset attempts(0-30 Sec.) are programmable. If the condition causing the fault is still present when the number of “reset/run tries” is exceeded, the drive will shut down and issue a “Max Retries Exceeded” Fault. This feature will not operate for ground faults or shorted output faults. If Automatic Bypass is provided as an option, the first drive fault encountered with Auto Bypass enabled will transfer the motor to bypass operation, making the reset function inoperable.

Dwell Frequency

In some applications, standard DC Boost or Volts-per-Hertz patterns may not provide the necessary starting torque. Applying a Dwell Frequency can develop motor flux before acceleration is required. By setting Dwell Frequency to rated motor slip or less, flux will develop in the motor under controlled current conditions. This “instant slip” creates the breakaway torque required. After dwell time expires the drive will accelerate to its commanded speed.

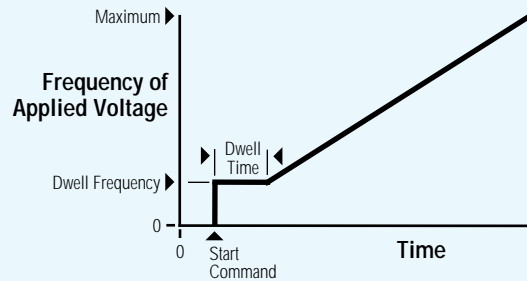

Custom Volts-per-Hertz

The 1336 PLUS offers a fully programmable Volts-per-Hertz option that allows complete motor optimization to produce maximum performance with minimum current. For those applications with tougher starting, acceleration or running torque requirements, Custom Volts-per-Hertz offers a powerful application tool.

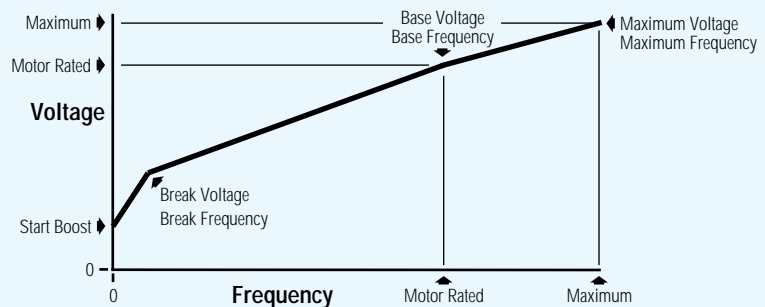

Auto Economizer

This feature combines stator flux control with an economizer routine to help the end user save energy costs. The Auto Economizer monitors drive current and compares it against the full load amps (Overload Amps) that the user has programmed into the drive. In load situations (i.e. idle) where the actual current draw of the motor is significantly less than the programmed overload amps, the drive will automatically begin reducing the output voltage to the motor. This minimizes flux current in a lightly loaded motor and results in a lower kW usage.

Power Loss Ride-Thru

The 1336 PLUS Configured Drive has the ability to ride through short power interruptions provided:

- Control power is supplied remotely and not affected by the power loss.

- A maintained Start/Stop 2-wire control scheme is used.

Either one or both configurations allow the drive to react to one of two programmed methods of operation on loss of input power.

DIAGRAM 1

With the Line Loss Fault parameter disabled, if a power interruption occurs (T1) the drive will continue to operate off stored DC bus energy until bus voltage drops to 85% of its nominal value (T2). At this point, the drive output is shut off, allowing the DC bus to discharge more slowly. The drive will retain its logic and operating status as long as bus voltage is above the absolute minimum bus voltage — refer to page 18. If bus voltage should fall below this level (T5), the drive will trip and Undervolt Fault will be displayed. If input power is restored before this minimum is reached (T3) and bus voltage rises above the 85% level (T4), the drive will restore output power to the motor and resume running.

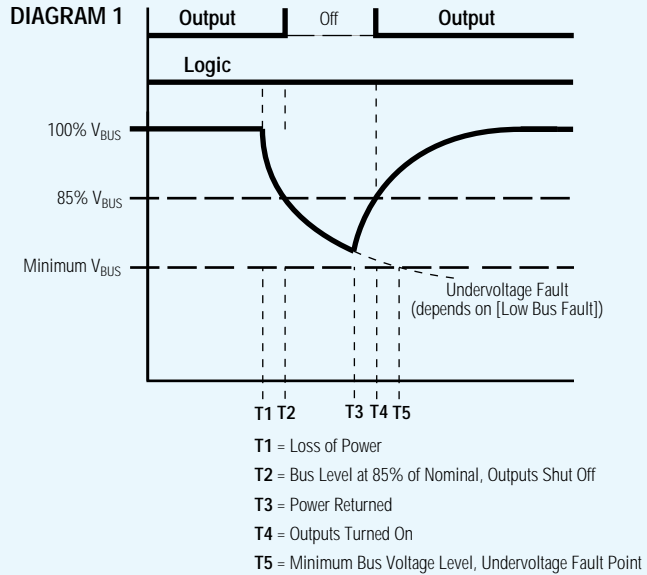
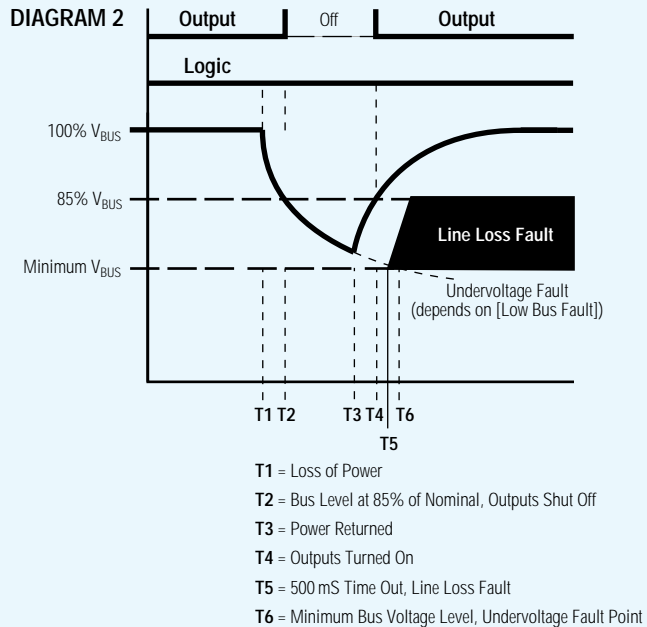

DIAGRAM 2

With the Line Loss Fault parameter enabled, if input power is lost (T1) the drive will continue to operate until the bus voltage falls below 85% of nominal (T2). At this point the drive output is turned off and a 500 mS timer is started. One of the following conditions will then occur:

- The bus voltage will fall below minimum before the time expires (T6). This will generate an Undervoltage Fault.
- The bus voltage will remain below 85% but above minimum and the timer expires (T5). This will generate a Line Loss Fault.
- The input power is restored (T3) and the bus voltage rises above the 85% level before the timer expires (T4). This allows the drive to turn its output on and resume running.



Fault Buffer

The 1336 PLUS contains a fault buffer that records the last four faults the drive experienced. The buffer stores faults in a first-in, first-out manner. Additional diagnostic parameters are listed in the Diagnostic Group — refer to the Parameter List on pages 28 & 29.

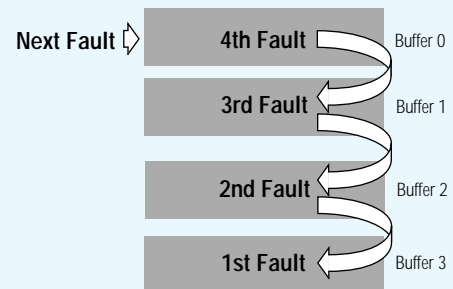

Traversal Function

The 1336 PLUS output frequency can be programmed to modulate around a set frequency. This is accomplished by programming three parameters to develop an inertia compensated triangular waveform — Traverse Period, Max Traverse, and P Jump. In surface driven winding applications, the waveform developed can be used by traverse drives to perform the traverse function electronically.

A traverse drive will move the thread back and forth in a diamond pattern to distribute the thread evenly across a tube surface. To prevent a build up of thread at the same points on the surface, this pattern must be altered. This can be accomplished by continuously varying the speed of the traverse in a cyclical manner over a specified speed range. With the use of inertia compensation, the result is a series of distributed diamond patterns over the entire tube surface.

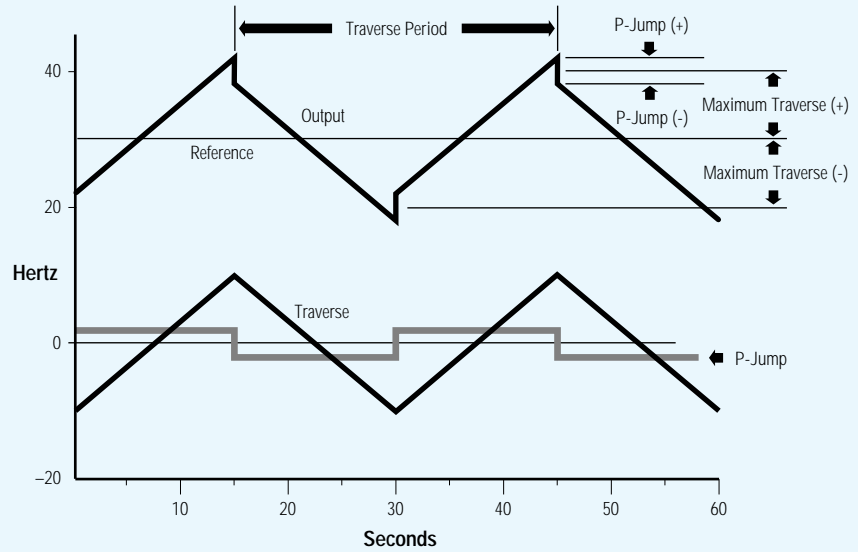

Slip Compensation

To develop torque in an induction motor, rotor speed “slips” relative to stator speed. The amount of slip is proportional to the motor load. While this increased slip provides the necessary torque, load speed is sacrificed. For those applications where this speed decrease is unacceptable, the 1336 PLUS offers Slip Compensation. As load increases, the drive automatically increases output frequency to provide needed motor slip without a decrease in speed. The amount of compensation is proportional to the load increase, allowing one setting for the entire speed range. The 1336 PLUS Slip Compensation function can provide typical speed regulation of 0.5%.

- Slip compensation is based on programmed motor flux instead of drive rated amps, providing more accurate speed regulation.
- Slip compensation is active for both steady state and accel/decel conditions.
- Dynamic response to load changes is parameter adjustable.
- Slip compensation enhances torque performance at all speeds.

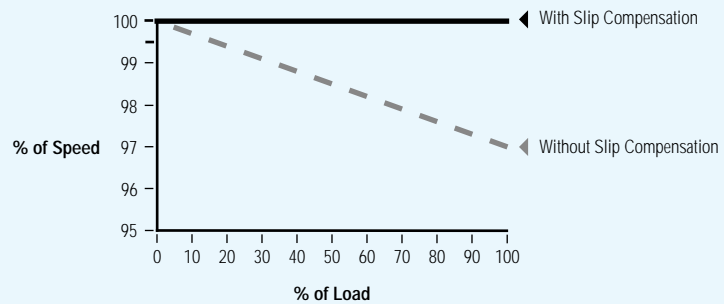

Line Loss Reconnect

In the event that a line loss condition occurs, the 1336 PLUS provides a variety of programmable selections to control the timing and method of reconnecting the motor after power returns. Choices include:

- Reconnect at zero Hertz.
- Use flying start to determine motor speed.
- Check for motor terminate voltage to determine motor speed.
- Read the encoder, if present.
- Reconnect at last known output frequency.

Process Display

In order to provide complete flexibility in monitoring drive performance, the 1336 PLUS offers a Process Mode for the liquid crystal super-twist display on the Human Interface Module. This feature provides two lines of 16 characters each that can display any two drive parameters scaled into user selectable units. Each line uses 8 value display characters and 8 programmable text characters to create the process display.

Simple keystrokes can designate the process display as the standard display shown at power up.

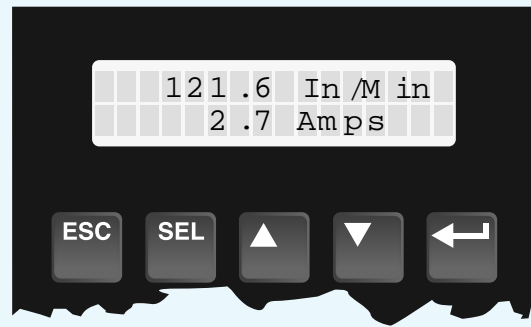

Owners

The 1336 PLUS displays which of the available adapters currently “owns” certain control functions. To avoid conflict, some owners are exclusive (only one device can issue a frequency reference), while others can have multiple control (many devices can simultaneously issue a start command). Owner displays are excellent diagnostic tools, displaying precisely where drive control commands are coming from.

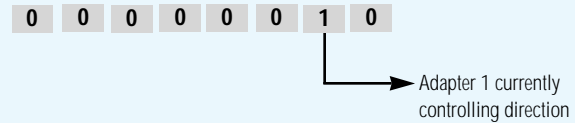

Typical Owner Frequency Source

Masks

All external control connections to the 1336 PLUS are made through a multi-connection communication bus called SCANport. Drives up to and including 3.7 kW (5 HP) have 5 available adapter ports while larger drives have 6 ports. With the possibility of many devices able to issue drive control functions (start, stop, reverse, speed reference, etc.), the 1336 PLUS offers a mask for each control function that gives the user complete flexibility to lock out any function (except stop) from any port.

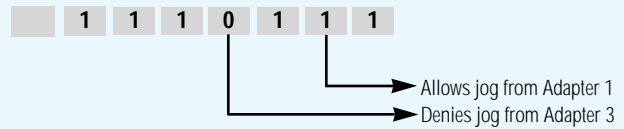

Typical Jog Mask

Process PI Control

Simple process control, monitoring a feedback device and adjusting drive output according to feedback requirements can be accomplished with the 1336 PLUS. Proportional and integral gain adjustments plus feedback scaling, error inversion, output clamping and integrator reset functions allow the Process PI function to control the output of the 1336 PLUS based on the PI reference (setpoint) and the PI feedback. If the feedback device indicates that the process is moving away from the desired setpoint, the PI software responds by adjusting the drive output until the feedback again equals the setpoint. Selectable inputs provide “auto/manual” capability for open loop threading operation. Programmable presets and preloads assure smooth transitions.

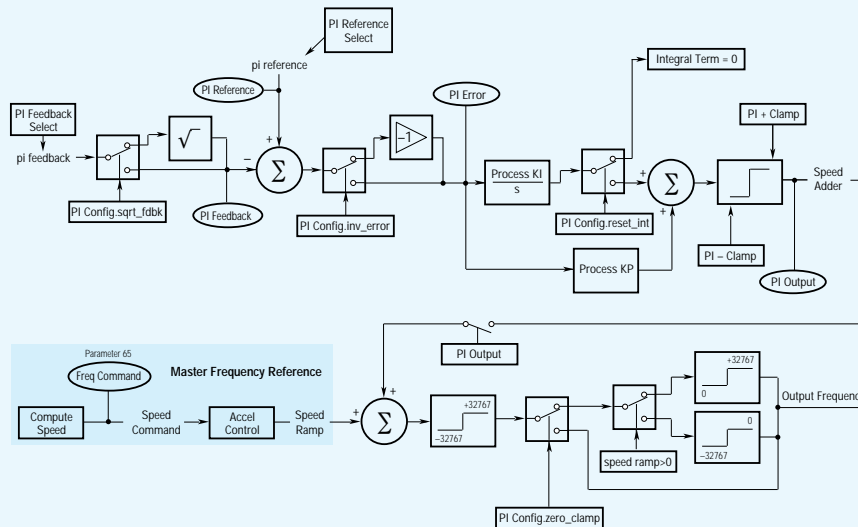

4-20mA Loss Select

Many control systems issue a 4-20 mA control signal for the drive to use as a speed reference. The drive will run at minimum speed with a 4 mA signal and maximum speed with a 20 mA signal. The drive can also invert this signal to run minimum speed at 20 mA and maximum speed at 4 mA. Since a minimum signal of 4 mA is required, the drive must have a “fall back” instruction in the event of a signal loss (failed transducer or broken wire). The 1336 PLUS contains a “loss select” parameter that offers five choices for signal failure mode.

1. Stop the drive and issue a fault.
2. Go to minimum speed and issue a warning.
3. Go to maximum speed and issue a warning.
4. Maintain speed and issue a warning.
5. Go to a preset speed and issue a warning.

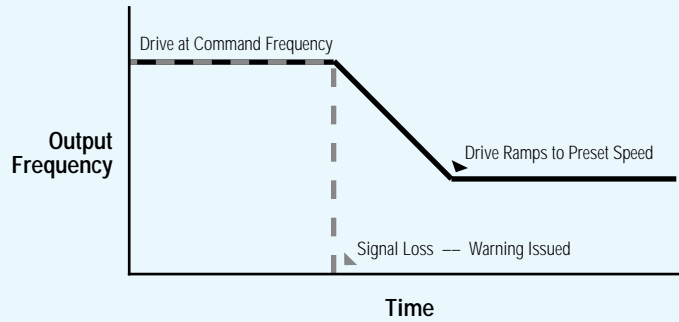

Run On Power Up

For applications that require unattended operation, the 1336 PLUS offers the ability to resume running once power is restored after a power outage. If "Run On Power Up" is activated and input power is lost, when power is restored the drive will automatically restart and run at current command speed if all required signals are present (Enable, Auxiliary, Not-Stop and Start).

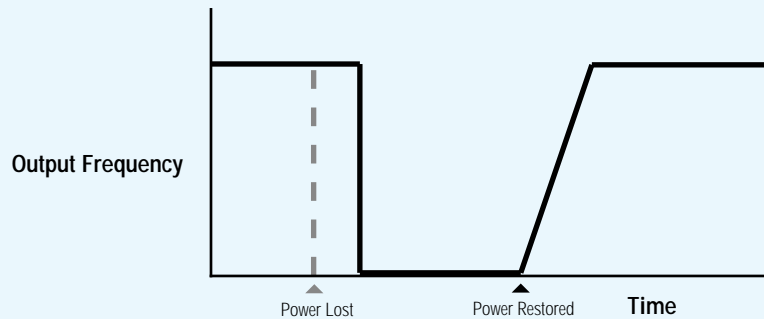

Braking

Many applications require a “holding brake” function to stop motor rotation between operations. The 1336 PLUS provides a programmable DC Hold level and DC Hold time to develop holding torque in the motor after a ramp-to-stop.

For applications that require a quick stopping time, the 1336 PLUS can “inject” a DC voltage into the motor for a programmed time to brake the motor to a stop. While this does not take the place of an external brake for emergency stopping, it is an effective stopping method under normal operation.

The drive is capable of extended or unlimited injection braking for both stopping and holding a motor. It provides:

- Injection braking at selectable levels for extended periods up to 90 seconds.
- Extended Hold Braking (up to 90 seconds).
- Continuous (event ended) Hold Braking. This is accomplished by setting the Stop mode to “Ramp to Hold”. In this mode, the drive will decelerate according to the programmed decel ramp. When the drive reaches zero Hertz output, it will supply programmed current for hold braking per the DC Hold Level parameter (limited to 70% of drive rating) until;
 - a) A Start command is issued *or*
 - b) the Enable input is opened.

Ramp-to-Stop

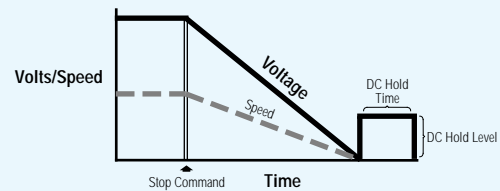

Brake-to-Stop

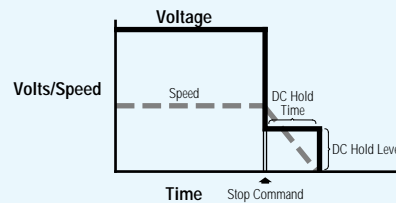

Ramp-to-Hold

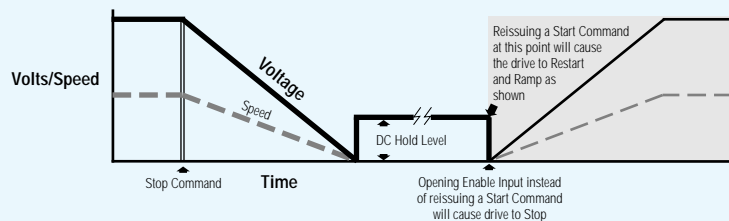

Parameter List

The 1336 PLUS uses an extensive set of parameters divided into groups for ease of programming. Grouping replaces a sequentially numerical parameter list with functional parameter groups that increases operator efficiency and helps reduce programming time.

Group/Param.	No.	Disp. Units	Min./Max. Values	Default ①
Output Current	54	0.1A	0/200% Rtd. Drv. Out. Current	None
Output Voltage	1	1 Volt	0/200% Rtd. Drv. Out. Volts	None
Output Power	23	1 kW	±200% Rtd. Drv. Out. Power	None
DC Bus Voltage	53	1 Volt	0/200% DC Bus Volt. Max.	None
Output Freq	66	0.01 Hertz	±400.00 Hz	None
Freq Command	65	0.01 Hertz	±400.00 Hz	None
4-20 mA Hertz	140	0.01 Hertz	0.00/400.00 Hz	None
0-10 Volt Hertz	139	0.01 Hertz	0.00/400.00 Hz	None
Pot Hertz	138	0.01 Hertz	0.00/400.00 Hz	None
Pulse/Enc Hertz	63	0.01 Hertz	0.00/400.00 Hz	None
MOP Hertz	137	0.01 Hertz	0.00/400.00 Hz	None
Heatsink Temp	70	1° C	0/255° C	None
Power OL Count 4.01	84	1 %	0/200%	None
Motor OL Count 4.01	202	1 %	0/200%	None
Last Fault	4	Fault #	None	None
Torque Current	162	0.1A	±200% Drive Rating	None
Flux Current	163	0.1A	±200% Drive Rating	None
% Output Power	3	1 %	±200% Output Power	None
% Output Curr	2	1 %	0/200% Output Current	None
Setup				
Input Mode	21	Mode #	1/24 (16 f/m < 4.01)	1
Freq Select 1	5	Settings	Selection Parameter	Adapter 1
Accel Time 1	7	0.1 Second	0.0/3600.0 Sec (600.0 f/m < 4.01)	10.0 Sec
Decel Time 1	8	0.1 Second	0.0/3600.0 Sec (600.0 f/m < 4.01)	10.0 Sec
Base Frequency	17	See "Motor Control" Group 4.01		
Base Voltage	18	See "Motor Control" Group 4.01		
Maximum Voltage	20	See "Motor Control" Group 4.01		
Minimum Freq	16	1 Hertz	0/120 Hz	0 Hz
Maximum Freq	19	1 Hertz	25/400 Hz	60 Hz
Stop Select 1	10	Settings	Selection Parameter	Coast
Current Limit	36	1%	20/160% Output Current	150%
Current Lmt Sel 4.01	232	Settings	Selection Parameter	Current Lmt
Adaptive I Lim 4.01	227	Settings	Selection Parameter	Enabled
Overload Mode	37	Settings	Selection Parameter	No Derate
Overload Amps	38	0.1A	20/115% Drive Rated Amps	115% Drv. Rtd. A
VT Scaling	203	Settings	Selection Parameter	Disabled
Motor NP RPM	177	1 RPM	60/24000 RPM	1750 RPM
Motor NP Hertz	178	1 Hertz	1/400 Hz	60 Hz
Motor NP Volts 4.01	190	1 Volt	0/2 x Drive Rated Volts	Drive Rated Volts
Motor NP Amps 4.01	191	1 Amp	0/2 x Drive Rated Amps	Drive Rated Amps
Advanced Setup				
Minimum Freq	16	1 Hertz	0/120 Hz	0 Hz
Maximum Freq	19	1 Hertz	25/400 Hz	60 Hz
Base Frequency	17	See "Motor Control" Group 4.01		
Base Voltage	18	See "Motor Control" Group 4.01		
Break Frequency	49	See "Motor Control" Group 4.01		
Break Voltage	50	See "Motor Control" Group 4.01		
Maximum Voltage	20	See "Motor Control" Group 4.01		
DC Boost Select ②	9	Settings	Selection Parameter	Auto 30%
Start Boost	48	See "Motor Control" Group 4.01		
Run Boost	83	See "Motor Control" Group 4.01		
Run/Accel Boost ②	169	1%	0/100% of Auto Boost Setting	100%
PWM Frequency	45	2 kHz	2-10 kHz (A Frame)	Based on Drv Type
		2 kHz	2-8 kHz (B Frame)	Based on Drv Type
		2 kHz	2-6 kHz (C Frame & Up)	Based on Drv Type
Analog Invert ②	84	Settings	Selection Parameter	Disabled
Analog Trim En	90	Settings	Selection Parameter	Disabled
4-20 Loss Sel	150	Settings	Selection Parameter	Min/Alarm
Accel Time 2	30	0.1 Second	0.0/3600.0 Sec (600.0 f/m < 4.01)	10.0 Sec
Decel Time 2	31	0.1 Second	0.0/3600.0 Sec (600.0 f/m < 4.01)	10.0 Sec
Stop Select 1	10	Settings	Selection Parameter	Coast
DC Hold Time	12	1 Second	0/90.0 Sec (15 f/m < 4.01)	0 Sec

Group/Param.	No.	Disp. Units	Min./Max. Values	Default ①
Advanced Setup (continued)				
DC Hold Level	13	1%	0/150%	100%
Hold Level Sel 4.01	231	Settings	Selection Parameter	DC Hold Lvl
Bus Limit En	11	Settings	Selection Parameter	Disabled
Motor Type	41	Settings	Selection Parameter	Induction
Stop Select 2	52	Settings	Selection Parameter	Coast
KI Amps 2.03-3.01	192	None	25/800	100
KP Amps 2.03	193	None	25/800	100
Frequency Set				
Freq Select 1	5	Settings	Selection Parameter	Adapter 1
Freq Select 2	6	Settings	Selection Parameter	Preset 1
Jog Frequency	24	0.1 Hertz	0.0/400.0 Hz	10.0 Hz
Preset Freq 1	27	0.1 Hertz	0.0/400.0 Hz	0.0 Hz
Preset Freq 2	28	0.1 Hertz	0.0/400.0 Hz	0.0 Hz
Preset Freq 3	29	0.1 Hertz	0.0/400.0 Hz	0.0 Hz
Preset Freq 4	73	0.1 Hertz	0.0/400.0 Hz	0.0 Hz
Preset Freq 5	74	0.1 Hertz	0.0/400.0 Hz	0.0 Hz
Preset Freq 6	75	0.1 Hertz	0.0/400.0 Hz	0.0 Hz
Preset Freq 7	76	0.1 Hertz	0.0/400.0 Hz	0.0 Hz
Skip Freq 1	32	1 Hertz	0/400 Hz	400 Hz
Skip Freq 2	33	1 Hertz	0/400 Hz	400 Hz
Skip Freq 3	34	1 Hertz	0/400 Hz	400 Hz
Skip Freq Band	35	1 Hertz	0/15 Hz	0 Hz
MOP Increment	22	10 Hertz/Sec	0/78% [Max. Freq]/Sec	1.1 Hz/Sec
Save MOP Ref 4.01	230	Settings	Selection Parameter	Disabled
Freq Ref SqRoot 4.01	229	Settings	Selection Parameter	Disabled
Pulse/Enc Scale	46	1 PPR	1/4096	1024 PPR
Feature Select				
Dwell Frequency	43	0.1 Hertz	0.0/7.0 Hz	0.0 Hz
Dwell Time	44	1 Second	0/10 Sec	0 Sec
Speed Control	77	Settings	Selection Parameter	Slip Comp
Slip @ F.L.A.	42	0.1 Hertz	0.0/10.0 Hz (5.0 f/m < 4.01)	1.0 Hz
Slip Comp Gain 4.01	195	None	1/40	1
Run On Power Up	14	Settings	Selection Parameter	Disabled
Reset/Run Tries	85	1 Try	0/9	0 Tries
Reset/Run Time	15	0.1 Second	0.5/30.0 Sec	1.0 Sec
S Curve Enable	57	Settings	Selection Parameter	Disabled
S Curve Time	56	0.1 Second	0.0/1800.0 Sec (300.0 f/m < 4.01)	0.0 Sec
Language	47	Settings	Selection Parameter	English
Speed Control	77	See above 4.01		
Flying Start En	155	Settings	Selection Parameter	Disabled
FStart Forward	156	1 Hz	0/400 Hz	60 Hz
FStart Reverse	157	1 Hz	0/400 Hz	0 Hz
LLoss Restart 4.01	228	Settings	Selection Parameter	Track Volts
Traverse Period	78	0.01 Sec	0.00/30.00 Sec	0.00 Sec
Max Traverse	79	0.01 Hz	0.00/50% [Maximum Freq]	0.00 Hz
P Jump	80	0.01 Hz	0.00/25% [Maximum Freq]	0.00 Hz
I/O Config				
Input Mode	21	Mode #	1/24 (16 f/m < 4.01)	1
CR1 Out Select 4.01	158	Settings	Selection Parameter	At Speed
CR2 Out Select 4.01	174	Settings	Selection Parameter	Running
CR3 Out Select 4.01	175	Settings	Selection Parameter	Fault
CR4 Out Select 4.01	176	Settings	Selection Parameter	Alarm
Digital Out Sel ③	158	Settings	Selection Parameter	At Speed
Dig Out Freq	159	0.01 Hz	0.00 Hz/[Maximum Freq]	0.00 Hz
Dig Out Current	160	0% Rated	0/200%	0%
Dig Out Torque	161	0.1A	0.0/200% of [Rated Amps]	0.0A
Set 0-10 Vlt Lo 4.01	237	0.1%	±300.0%	0.0%
Set 0-10 Vlt Hi 4.01	238	0.1%	±300.0%	100.0%
Set 4-20 mA Lo 4.01	239	0.1%	±300.0%	0.0%
Set 4-20 mA Hi 4.01	240	0.1%	±300.0%	100.0%
Analog Out Sel	25	Settings	Selection Parameter	Frequency
Anlg Out Offset	154	Settings	Selection Parameter	Disabled
Abs Analog Out 4.01	233	Settings	Selection Parameter	Disabled
Set Anlg Out Lo 4.01	234	0.1%	±300.0%	0.0%
Set Anlg Out Hi 4.01	235	0.1%	±300.0%	100.0%
Faults				
Fault Buffer 0	86	Fault Code	Fault Storage	None
Fault Buffer 1	87	Fault Code	Fault Storage	None
Fault Buffer 2	88	Fault Code	Fault Storage	None

2.01 Firmware version 2.01 or later. 2.03 Firmware version 2.03 or later. 3.01 Firmware version 3.01 or later. 4.01 Firmware version 4.01 or later.

① Default Values shown are for standard 1336 PLUS drives. Configured Drive default values are reprogrammed to accommodate ordered options when shipped.

② Firmware versions before 4.01 only.

③ These parameters are located in the "Diagnostics" group for firmware versions before 2.01.

Parameter List

Group/Param. No.	Disp. Units	Min./Max. Values	Default	
Faults (continued)				
Fault Buffer 3	89	Fault Code	Fault Storage	None
Clear Fault	51	Settings	Selection Parameter	Ready
Cur Lim Trip En	82	Settings	Selection Parameter	Disabled
Shear Pin Fault ^{4.01}	226	Settings	Selection Parameter	Disabled
Motor OL Fault ^{4.01}	201	Settings	Selection Parameter	Enabled
Line Loss Fault	40	Settings	Selection Parameter	Disabled
Blwn Fuse Flt	81	Settings	Selection Parameter	Enabled
Low Bus Fault	91	Settings	Selection Parameter	Enabled
Fault Data ^{4.01}	207	Param. #	1/255	None
Flt Motor Mode	143	Settings	Read Only	None
Flt Power Mode	144	Settings	Read Only	None
Fault Frequency	145	0.01 Hertz	0.00/400.00 Hz	None
Flt Driv Status	146	Bit 1/0	Read Only	None
Fault Alarms	173	Bit 1/0	Read Only	None
Flt Clear Mode	39	Settings	Selection Parameter	Enabled
Ground Warning ^{2.01}	204	Settings	Selection Parameter	Disabled
Diagnostics				
Drive Status	59	Bit 1/0	Read Only	None
2nd Drive Sts ^{4.01}	236	Bit 1/0	Read Only	None
Drive Alarm	60	Bit 1/0	Read Only	None
Latched Alarms ^{2.01}	205	Bit 1/0	Read Only	None
Input Status	55	Bit 1/0	Read Only	None
Freq Source	62	Settings	Read Only	None
Freq Command	65	0.01 Hertz	±400.00	None
Drive Direction	69	Settings	Read Only	None
Stop Mode Used	26	Settings	Read Only	None
Motor Mode	141	Settings	Read Only	None
Power Mode	142	Settings	Read Only	None
Output Pulses	67	1 Pulse	0/65535	None
Current Angle	72	1 Deg.	Read Only	None
Heatsink Temp	70	1 Deg. C	0/255° C	None
Set Defaults	64	Settings	Selection Parameter	Ready
DC Bus Memory ^{2.03}	212	1 Volt	Read Only	None
EEPROM Cksum ^{4.01}	172	None	Read Only	None
Ratings ^②				
Drive Type	61	None	Read Only	Factory Set
Firmware Ver.	71	None	Read Only	Factory Set
Drive Rtd Volts	147	1 Volt	Read Only	Drive Rating
Rated Amps	170	0.1A	Read Only	Drive Rating
Rated kW	171	1 kW	Read Only	Drive Rating
Rated CT Amps	148	0.1A	Read Only	Drive Rating
Rated CT kW	149	1 kW	Read Only	Drive Rating
Rated VT Amps	198	0.1A	Read Only	Drive Rating
Rated VT kW	199	1 kW	Read Only	Drive Rating
Masks				
Direction Mask	94	Bit 1/0	0/1	01111110
Start Mask	95	Bit 1/0	0/1	01111111
Jog Mask	96	Bit 1/0	0/1	01111111
Reference Mask	97	Bit 1/0	0/1	01111111
Accel Mask	98	Bit 1/0	0/1	01111111
Decel Mask	99	Bit 1/0	0/1	01111111
Fault Mask	100	Bit 1/0	0/1	01111111
MOP Mask	101	Bit 1/0	0/1	01111111
Logic Mask	92	Bit 1/0	0/1	01111111
Local Mask	93	Bit 1/0	0/1	01111111
Alarm Mask ^{2.01}	206	Bit 1/0	0/1	01111111
Owners				
Stop Owner	102	Bit 1/0	Read Only	None
Direction Owner	103	Bit 1/0	Read Only	None
Start Owner	104	Bit 1/0	Read Only	None
Jog Owner	105	Bit 1/0	Read Only	None
Reference Owner	106	Bit 1/0	Read Only	None
Accel Owner	107	Bit 1/0	Read Only	None
Decel Owner	108	Bit 1/0	Read Only	None
Fault Owner	109	Bit 1/0	Read Only	None
MOP Owner	110	Bit 1/0	Read Only	None
Local Owner	179	Bit 1/0	Read Only	None

^{2.01} Firmware version 2.01 or later. ^{2.03} Firmware version 2.03 or later. ^{3.01} Firmware version 3.01 or later. ^{4.01} Firmware version 4.01 or later.

① Default Values shown are for standard 1336 PLUS drives. Configured Drive default. values are reprogrammed to accommodate ordered options when shipped.
 ② Firmware versions before 4.01 only.
 ③ These parameters are located in the "Diagnostics" group for firmware versions before 2.01.

Group/Param. No.	Disp. Units	Min./Max. Values	Default	
Adapter I/O				
Data In (B)	111-118	Parameter #	None	0
Data Out (B)	119-126	Parameter #	None	0
Process Display				
Process 1 Par	127	Parameter #	None	1
Process 1 Scale	128	0.01	±327.67	1.00
Process 1 Txt 1-8	129-136	ASCII Code	None	Volts
Process 2 Par	180	Parameter #	None	54
Process 2 Scale	181	0.01	±327.67	1.00
Process 2 Txt 1-8	182-189	ASCII Code	None	Amps
Encoder Feedback				
Speed Control	77	Settings	Selection Parameter	Slip Comp
Encoder Type	152	Settings	Selection Parameter	Pulse
Pulse/Enc Scale	46	1 PPR	1/4096	1024 PPR
Maximum Speed	151	1 Hertz	0/400 Hz	400 Hz
Motor Poles	153	1 Pole	Read Only	None
Speed Ki	165	Numeric	0/20000	100
Speed Error	166	0.01 Hz	±8.33% [Base Frequency]	None
Speed Integral	167	0.01 Hz	±8.33% [Base Frequency]	None
Speed Adder	168	0.01 Hz	±8.33% [Base Frequency]	None
Motor NP RPM	177	1 RPM	60/24000 RPM	1750 RPM
Motor NP Hertz	178	1 Hertz	1/400 Hz	60 Hz
Pulse/Enc Hertz ^{2.01}	63	0.01 Hertz	0.00/400.00 Hz	None
Process PI ^{3.01}				
Speed Control	77	Settings	Selection Parameter	Slip Comp
PI Config	213	Bit 1/0	0/1	00000000
PI Status	214	Bit 1/0	Read Only	None
PI Ref Select	215	Settings	Selection Parameter	Preset 1
PI Fdbk Select	216	Settings	Selection Parameter	0-10 Volt
PI Reference	217	0.01 Hertz	±400.00 Hz	None
PI Feedback	218	0.01 Hertz	±400.00 Hz	None
PI Error	219	0.01 Hertz	±400.00 Hz	None
PI Output	220	0.01 Hertz	±400.00 Hz	None
KI Process	221	N/A	0/1024	128
KP Process	222	N/A	0/1024	256
PI Neg Limit	223	0.01 Hz	±400.00 Hz	-8.33% [Max Freq]
PI Pos Limit	224	0.01 Hz	±400.00 Hz	+8.33% [Max Freq]
PI Preload ^{4.01}	225	0.01 Hz	±400.00 Hz	0.00 Hz
Motor Control ^{4.01}				
Control Select ^{4.01}	9	Settings	Selection Parameter	Sens Vector
Flux Amps Ref ^{4.01}	192	0.1A	0.0/75% Drive VT Rtd. Amps	0.0A
IR Drop Volts ^{4.01}	194	1 Volt	0/25% Drive Rated Volts	0 Volts
Flux Up Time ^{4.01}	200	0.1 Sec	0/0.5.0 Sec	0.0 Sec
Start Boost	48	1 Volt	0/9.5% Drive Rated Volts	0 Volts
Run Boost	83	1 Volt	0/9.5% Drive Rated Volts	0 Volts
Boost Slope ^{4.01}	169	None	1.0/8.0	1.5
Break Voltage	50	1 Volt	0/50% Drive Rated Volts	25% Max. Rtd. Vlt.
Break Frequency	49	1 Hertz	0/120 Hz	25% [Max. Freq]
Base Voltage	18	1 Volt	25/120% Drive Rated Volts	Drive Rtd. Volts
Base Frequency	17	1 Hertz	25/400 Hz	60 Hz
Maximum Voltage	20	1 Volt	25/120% Drive Rated Volts	Drive Rtd. Volts

Fault List

Over 40 faults can be displayed through the Human Interface Module. The display indicates a fault by showing a brief text statement relating to the fault that will be displayed until a drive reset is initiated.

Fault Number	Display Name	Fault Description
02	Auxiliary Fault	Auxiliary Input Open
03	Power Loss Fault	Loss of Input Voltage
04	Undervolt Fault	Low Bus Voltage
05	Overvolt Fault	High DC Bus Voltage
06	Motor Stall Fault	Excessive Motor Current
07	Overload Fault	Excessive Motor Load
08	Overtemp Fault	Heatsink Overtemperature
09	Open Pot Fault	Open Potentiometer
10	Serial Fault	Serial Communications Interruption
11	Op Error Fault	Programming Error
12	Overcurrent Fit	Excessive Drive Output Current
13	Ground Fault	Ground Fault
19	Precharge Fault	Precharge Circuit Failure
22	Drive Fault Reset	Fault Contact Error
23	Loop Overn Fit	Microprocessor Loop Error
24	Motor Mode Fit	Motor Mode Fault
26	Power Mode Fault	Power Mode Fault
28	Timeout Fault	Microprocessor Timeout
29	Hertz Err Fault	Programming Error
30	Hertz Set Fault	Programming Error
31	Timeout Fault	Microprocessor Timeout
32	EEprom Fault	EEprom Fault
33	Max Retries Fault	Maximum Reset/Run Tries Exceeded
34	Run Boost Fault	Programming Fault
35	Neg Slope Fault	Programming Fault
36	Dia C Lim Fit	Diagnostic Current Limit Trip
37	P Jump Err Fit	P Jump Error Programming Fault
38	Phase U Fault	Phase U Open
39	Phase V Fault	Phase V Open
40	Phase W Fault	Phase W Open
41	UV Short Fault	UV Phase-to-Phase Short
42	UW Short Fault	UW Phase-to-Phase Short
43	VW Short Fault	VW Phase-to-Phase Short
46	Power Test Fit	Power Structure Self Test Fail
47	Xsistr Desat Fit	Transistor Desaturation
48	Reprogram Fault	Reprogram Fault – Factory Defaults
50	Pole Calc Fault	Motor Poles Programming Error
51	BGND 10mS	Microprocessor Loop Fault
52	FGND 10mS	Microprocessor Loop Fault
53	EE Init Read	EEPROM Fault
54	EE Init Value	EEPROM Fault
55	Temp Sense Open	Heatsink Thermistor Open Fault
56	Precharge Open	Precharge Circuit Fault
57	Ground Warning	Ground Fault Warning
58	Blwn Fuse Fit	Bus Fuse Blown
59-62	—	Reserved for Future Use
63	Shear Pin Fault	(Current Limit) Exceeded
64	Power Overload	Drive Rating Exceeded
65	Adptr Freq Err	Frequency Ref. Greater than 32767
66	EEPROM Checksum	Checksum Fault
68	ROM or RAM Fit	ROM or RAM Internal Memory Fault

Suggested Power Distribution Schemes

The power distribution schemes shown below are for typical configurations and offered as suggestions only. Actual specified configurations may vary with accepted design practices or code restrictions.

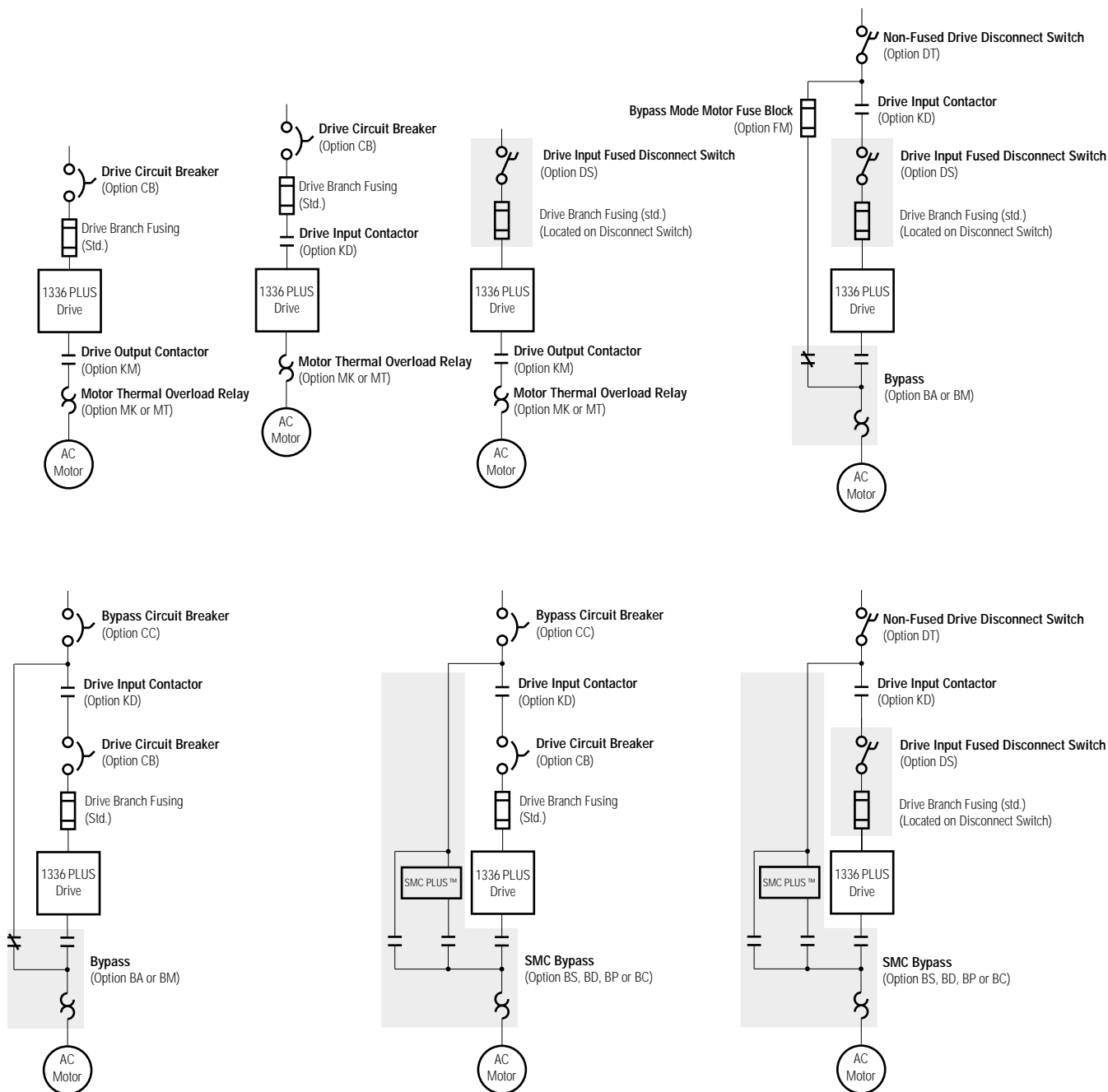

Power Disconnect Options

Drive Input Fuses¹
(Standard)

Drive input fuses provide branch circuit protection for the drive. Bussmann fuses and Bussmann fuse blocks are provided.
 Type LPJ (0.5-0.75 HP at 460V AC) (1 HP at 575V AC)
 Type JKS (0.5-125 HP at 230V AC) (1-250 HP at 460V AC) (2-250 HP at 575V AC)
 Type A3-70C-AT (300-600 HP at 460 or 575V AC)

Drive Input Circuit Breaker
(Option CB)

An input motor circuit protector or circuit breaker, with a padlockable door interlocked rotary or flange mounted operator handle is provided. The breaker is designed to meet the disconnect switch, short circuit and ground short protection requirements for motor branch circuit protection. Interrupt capability is as follows:

230V AC	0.5-15 HP 65,000A sym.	575V AC	7.5-450 HP 25,000A sym.
	20-100 HP 100,000A sym.		500-600 HP 22,000A sym.
460V AC	0.5-400 HP 65,000A sym.		
	450-600 HP 35,000A sym.		

Drive Input Fused Disconnect Switch²
(Option DS)

An Allen-Bradley Bulletin 194R or 1494F fused disconnect switch with a padlockable rotary or flange mounted operator handle is provided. The disconnect switch is designed to meet disconnect switch requirements for branch circuit protection.

Drive Input Contactor
(Option KD)

An Allen-Bradley Bulletin 100 contactor is provided between the AC line and the drive. The contactor will close on power up using A-B circuitry, or may be alternately controlled by customer supplied remote contact closure logic.

Drive Output Contactor
(Option KM)

An Allen-Bradley Bulletin 100 contactor is provided between the drive output and the motor. The contactor will close on power up, and open after a drive fault or loss of power.

Control Power Options

Drive Only Control Power
(Option CF)

This option provides a control power transformer mounted and wired inside the drive enclosure. The transformer is rated for drive and options power only. There is no additional capacity for customer use.

Drive Plus 250VA Control Power
(Option CP)

This option provides a control power transformer mounted and wired inside the drive enclosure. The transformer is rated for drive power plus an additional 250VA at 120V AC for customer use.

Drive Plus 500VA Control Power
(Option CT)

This option provides a control power transformer mounted and wired inside the drive enclosure. The transformer is rated for drive power plus an additional 500VA at 120V AC for customer use.

Thermal Overload Relay Options

Class 10 Motor Thermal Overload Relay³
(Option MT)

This option provides an Allen-Bradley Bulletin 193 solid state thermal overload relay. The Bulletin 193 contains an integral heater element with an adjustable trip setting — refer to **Motor Thermal Overload Relay Selection on page 80**. No additional heater elements are required. A Class 10 overload relay will trip in 10 seconds or less at 600% of motor current setting.

Class 20 Motor Thermal Overload Relay³
(Option MK)

This option provides an Allen-Bradley Bulletin 592 thermal overload relay. The Bulletin 592 contains a manual reset and requires a eutectic alloy heater element — refer to **Heater Element Selection on page 81**. The heater element is not supplied with this option. A Class 20 overload relay will trip in 20 seconds or less at 600% of motor current setting.

¹ Configured drives may have different input fuse ratings than those recommended for equivalent standard 1336 PLUS drives. Configured drives are rated for a single input voltage (not a voltage range) and may have fuses resident on an optional disconnect switch.

² Drive input fusing is incorporated in this device. Ratings above 300 HP will be hardware other than Allen-Bradley.

³ The motor overload protection provided by this option is redundant to the electronic overload protection provided as standard with the drive.

Bypass Options

Where system downtime cannot be tolerated, a bypass option can be provided to allow the motor to run at base speed by operating across the line.

Manual Bypass ^{1,2} (Option BM)

This option provides a means to manually switch a single motor from drive control to bypass (across the line) operation. Separate Bulletin 100 contactors are provided for drive output and bypass operation, and are electrically interlocked. A Bulletin 193 Class 10 overload is also provided for motor protection while operating in the bypass mode. A door mounted “Drive/Off/Bypass” selector switch is provided and “Drive Mode” and “Bypass Mode” pilot lights are available.

Auto Bypass ^{1,2} (Option BA)

This option provides a means to manually or automatically (upon a drive fault) switch a single motor from drive control to bypass (across the line) operation. Separate Bulletin 100 contactors are provided for drive output and bypass operation, and are electrically interlocked. A Bulletin 193 Class 10 overload is also provided for motor protection while operating in the bypass mode. Door mounted “Drive/Off/Bypass” and “Auto Bypass Off/On” selector switches are provided and optional “Bypass Mode” and “Auto Bypass Enable On” pilot lights are available.

Manual Bypass with SMC PLUS ^{1,2} Option BS

This option provides a means to manually switch a motor from drive control to bypass (across the line) operation. An SMC Plus™ solid state controller provides soft start capability when first switching to bypass operation. After the motor is up to speed the solid state controller will be bypassed also in order to eliminate the added heat generation within the enclosure. Separate Bulletin 100 contactors are provided for drive output, solid state controller output and total bypass. All contactors are electrically interlocked. A Bulletin 193 Class 10 overload is also provided for motor protection while operating in the bypass mode. A door mounted “Drive/Off/Bypass” selector switch is provided and optional “Drive Mode” and “Bypass Mode” pilot lights are available.

Auto Bypass with SMC PLUS ^{1,2} Option BD

This option provides a means to manually or automatically (upon a drive fault) switch a single motor from drive control to bypass (across the line) operation. An SMC Plus solid state controller provides soft start capability when first switching to bypass operation. After the motor is up to speed the solid state controller will be bypassed also in order to eliminate the added heat generation within the enclosure. Separate Bulletin 100 contactors are provided for drive output, solid state controller output and total bypass. All contactors are electrically interlocked. A Bulletin 193 Class 10 overload is also provided for motor protection while operating in the bypass mode. Door mounted “Drive/Off/Bypass” and “Auto Bypass Off/On” selector switches are provided and optional “Bypass Mode” and “Auto Bypass Enable On” pilot lights are available.

Manual Bypass with SMC/Pump Option ^{1,2} Option BP

This option provides a means to manually switch a single motor from drive control to bypass (across the line) operation. An SMC Plus (with the pump control option) solid state controller provides soft start and smooth acceleration and deceleration capability when first switching to bypass operation. After the motor is up to speed the solid state controller will be bypassed in order to eliminate the added heat generation within the enclosure. Separate Bulletin 100 contactors are provided for drive output, solid state controller output and total bypass. All contactors are electrically interlocked. A Bulletin 193 Class 10 overload is also provided for motor protection while operating in the bypass mode. A door mounted “Drive/Off/Bypass” selector switch is provided and optional “Bypass Mode” and “Bypass Mode” pilot lights are available.

¹ The Bypass Operation capability provided by this option does not allow for maintenance of the drive or entry into the enclosure with power applied while operating in the bypass mode.

² Bypass Options do not include the required 120V AC control power or motor branch protection. Control power may be supplied remotely by the user, or as part of the drive package by supplying one of option choices CF, CP or CT (refer to **page 32**). Motor branch protection may be provided by specifying option FM **page 34**.

Bypass Options (continued)

Auto Bypass with SMC/Pump Option ^{1,2}
(Option BC)

This option provides a means to manually or automatically (upon a drive fault) switch a single motor from drive control to bypass (across the line) operation. An SMC PLUS (with the pump control option) solid state controller provides soft start and smooth acceleration and deceleration capability when first switching to bypass operation. After the motor is up to speed the solid state controller will be bypassed also in order to eliminate the added heat generation within the enclosure. Separate Bulletin 100 contactors are provided for drive output, solid state controller output and total bypass. All contactors are electrically interlocked. A Bulletin 193 Class 10 overload is also provided for motor protection while operating in the bypass mode. Door mounted “Drive/Off/Bypass” and “Auto Bypass Off/On” selector switches are provided and optional “Bypass Mode” and “Auto Bypass Enable On” pilot lights are available.

Bypass Mode Motor Fuse Block
(Option FM)

This option provides a fuse block only. Fuses may be customer supplied and installed. This option is used in conjunction with the bypass option for motor short circuit protection.

Bypass Mode Circuit Breaker
(Option CC)

This option provides a motor circuit protector or circuit breaker with a padlockable door interlocked rotary or flange mounted operator handle. The circuit breaker is designed to meet disconnect switch, short circuit and ground short protection requirements for motor branch circuit protection. Interrupt capability is as follows:

230V AC	0.5-15 HP	65,000A sym.	575V AC	7.5-450 HP	25,000A sym.
				500-600 HP	22,000A sym.
460V AC	0.5-400 HP	65,000A sym.			
				450-600 HP	35,000A sym.

Bypass Mode Non-Fused Disconnect Switch ³
(Option DT)

An Allen-Bradley Bulletin 194R or 1494F non-fused disconnect switch with a padlockable door interlocked rotary or flange mounted operator handle is provided. The disconnect switch is designed to meet disconnect switch requirements for branch circuit protection.

Motor Interface Options

Blower Motor Starter
(Option MB)

This option provides motor fuses, an Allen-Bradley Bulletin 100 contactor and an Allen-Bradley Bulletin 193 Class 10 thermal overload relay. The blower starter is electrically interlocked with the drive enable function or the bypass contactor (if bypass is provided and selected). The blower motor will be assumed to be 1 HP unless motor data is supplied with the order.

Motor Heater Control
(Option MH)

This option provides the drive control circuitry for an existing motor heater. The heater is interlocked with the drive run relay and will be energized whenever drive power is removed (requires a separate 120V AC Power source). Option includes 360W power output and a white Motor Heater On pilot light mounted on the enclosure door.

RTD Protection Module

This option provides RTD protection modules that monitor up to three motor mounted RTDs. The module has the following output contacts with adjustable set points — Pre-Alarm, Alarm, and Trip.

(Option N6)	120 Ohm Nickel
(Option N7)	10 Ohm Copper
(Option N8)	100 Ohm Platinum

Thermistor Sensing Relay
(Option N9)

A Sprecher & Schuh Type RT3-M Thermistor Protection Relay is supplied. The relay is interfaced to a thermistor generally located in the stator winding of the motor. The relay will shut down the drive when sensing a motor overtemperature condition. Automatic, manual, and remote reset capabilities are also provided.

¹ The Bypass Operation capability provided by this option does not allow for maintenance of the drive or entry into the enclosure with power applied while operating in the bypass mode.



² Bypass Options do not include the required 120V AC control power or motor branch protection. Motor branch protection may be provided by specifying option FM from above. Control power may be supplied remotely by the user, or as part of the drive package by supplying one of option choices CF, CP or CT (refer to **page 32**).

³ 300 HP and above will be hardware other than A-B.

Input and Output Line Reactor Options

NEMA Type 1 Line Reactor ¹ (Option LR) Input (Option LO) Output	This option provides an open core line reactor which mounts inside the NEMA Type 1 drive enclosure. Reactor Specifications: Iron core, 3% impedance, Class H insulation, 115°C rise, copper wound, 50/60 Hz.
NEMA Type 4/12 Line Reactor ¹ (Option LT) Input (Option LW) Output	This option provides an open core line reactor which mounts inside NEMA Type 4 or 12 drive enclosures. Reactor Specifications: Iron core, 3% impedance, Class H insulation, 115°C rise, copper wound, 50/60 Hz.
Common Mode Choke ¹ (Option CM)	This option will help reduce the common mode noise at the drive output, and help guard against nuisance tripping of the drive caused by capacitive leakage effects. Capacitive currents are larger at higher PWM frequencies.

Control and Feedback Options

Auxiliary Contacts (Option JM) Alarm (Option JT) At Speed (Option JC) Control Power On (Option JF) Drive Fault (Option JR) Drive Run	Drive Rating			
	230V AC	460V AC-CT	460V AC-VT	575V AC
Figure 1 	0.5-125 HP	0.5-200 HP	0.5-250 (292A) HP	1-300 HP
Figure 2 	—	250-600 HP	250 (325A)-600 HP	350-600 HP
Isolated Analog Input (Option N3)	This option provides an isolator for the analog input speed reference to the drive and is mounted and wired in the drive enclosure. The default (as shipped) setting will be to accept a remote 4-20mA input. The isolator may be reconfigured by the user to accept any input signal in the range of 0-256V DC or 0-100mA, with or without offset and optional inverse operation.			
Isolated Analog Output (Option N2)	This option provides an isolator for the analog output speed reference to the drive and is mounted and wired in the drive enclosure. The default (as shipped) setting will be to accept a remote 4-20mA output proportional to frequency. The standard drive analog output may be reprogrammed by the user to be proportional to current, power or DC Bus voltage. The isolator may be reconfigured by the user to provide any output signal in the range of 0-10V DC or 0-20mA, with optional inverse operation.			
Isolated Analog Outputs (2) (Option JA)	This option provides two isolated 4-20mA outputs. One output is from the drive and is proportional to drive output frequency. The drive output may be reprogrammed to indicate current or torque. The other output is from an AC current sensor in the output of the drive and is proportional to drive output current.			
Encoder Feedback	Refer to Control Interface Options on page 36.			
3-15 PSI Transducer (Local) Feedback (Option N4C — Speed Command) (Option N4T — Speed Trim)	This option provides a 4-wire, 3-15 PSI transducer mounted inside the enclosure. The transducer accepts air pressure only with a 1/4" NPT fitting and generates an isolated output of 4-20mA proportional to the input pressure. The 4-20mA signal is fed to the drive as either a speed command or speed trim.			
3-15 PSI Transducer (Remote) Feedback (Option N5C — Speed Command) (Option N5T — Speed Trim)	This option provides a 2-wire, 3-15 PSI transducer as a loose item for remote mounting. The transducer accepts air or fluid pressure with a 1/4" NPT fitting and generates an isolated output of 4-20mA proportional to the input pressure. The 4-20mA signal is fed to the drive as either a speed command or speed trim.			

Communication Options

Single Point RIO ² (Option GM1C or GD1C)	RIO communication options provide a single point remote I/O interface board. The board can be configured for 1/4, 1/2, 3/4 or full rack with a baud rate of 57.6, 115, or 230 kBaud. The remote I/O Board may be set up by the user to control drive logic, control speed reference commands, monitor drive status and monitor drive logic.
RS232/422/485, DF1 or DH485 Protocol ² (Option GM2C or GD2C)	Communication interface module

¹ Contact Allen-Bradley for possible enclosure size changes when selecting this option.

² GM Series Options are drive mounted (maximum of one). GD Series Options are panel mounted.

PLC and SLC Control Options

PLC Hardware and Mounting^{1,2}
(Option JL)

This options provides PLC hardware mounted in the drive or option enclosure. Option includes a maximum of:
16 Position Rack (1771-A4B)
16 Amp Power Supply (1771-P7)
Interconnect Cable
(no programming included)

SLC 500™ Hardware and Mounting^{1,2}
(Option JS)

This options provides SLC 500 hardware mounted in the drive or option enclosure. Option includes a maximum of:
13 Position Rack (1746-A13)
Power Supply (1746-P2)
Interconnect Cable)

Control Interface Options

All 1336 PLUS Configured Drives come with a 115V AC Control interface Card (Option L6) unless otherwise specified. 24V AC/DC control and Contact Closure control are available as options. Encoder feedback is also available as an option with any of the three control methods.

All control interface cards provide input terminals for access to fixed drive functions that include start, stop, remote auxiliary, speed, and enable. Four additional inputs are programmed for functions such as reverse, preset speed access, jog, second accel/decel time access and local control selection. The function of each input is defined through programming. For Configured Drives, functions are pre-programmed at the factory for a specific application and configuration and should not require field re-programming.

Operator control devices provided as part of the drive package will be interfaced to these same input terminals. All control input terminals are optically isolated from the drive internal control logic.

Optional encoder feedback is available for use with single-ended or differential type encoders. When using a single ended encoder there is a 12V DC power supply available for customer use. Differential encoders will require a user supplied power supply.

Contact Closure Control Interface
(Option L4C — Without Encoder Feedback)
(Option L4EC — With Encoder Feedback)

Circuits used with Option L4C or L4EC must be capable of operating with **low = true logic**.
In the low state, external circuits must be capable of a sinking current of approximately 10 mA to pull the terminal voltage low to 3.0V DC or less.
In the high state, external circuits must allow the terminal voltage to rise to a voltage of 4.0-5.0V DC.
Note: Reed type input devices are recommended.
The L4C/L4EC option is compatible with the following Allen-Bradley PLC modules:
• 1771-OYL • 1771-OZL

+24V AC/DC Control Interface
(Option L5C — Without Encoder Feedback)
(Option L5EC — With Encoder Feedback)

Circuits used with Option L5C or L5EC must be capable of operating with **high = true logic**.
DC external circuits in the low state must generate a voltage of no more than 8V DC. Leakage current must be less than 1.5 mA into a 2.5k ohm load.
AC external circuits in the low state must generate a voltage of no more than 10V AC. Leakage current must be less than 2.5 mA into a 2.5k ohm load.
Both AC and DC external circuits in the high state must generate a voltage of +20 to +26 volts and source a current of approximately 10 mA for each input.
The L5C/L5EC option is compatible with the following Allen-Bradley PLC modules:
• 1771-OB • 1771-OBN • 1771-OQ16 • 1771-OZL • 1771-OB16
• 1771-OBD • 1771-OQ • 1771-OYL • 1771-OBB

115V AC Control Interface
(Standard L6 Interface — Without Encoder Feedback)
(Option L6EC — With Encoder Feedback)

Circuits used with the standard L6 interface or Option L6EC must be capable of operating with **high = true logic**.
In the low state, circuits must generate a voltage of no more than 30V AC. Leakage current must be less than 10 mA into a 6.5k ohm load.
In the high state, circuits must generate a voltage of 90-115V AC ±10% and source a current of approximately 20 mA for each input.
The L6C/L6EC option is compatible with the following Allen-Bradley PLC modules:
• 1771-OW • 1771-OWN
• 1771-OA • 1771-OAD (Contact Factory for Recommended Series/Rev. Level)

¹ Rack size will impact enclosure size. Contact Allen-Bradley for possible enclosure size changes.

² Actual hardware list will be determined at time of order entry.

Human Interface Modules — NEMA Type 1 and 12 Door Mounted HIMs

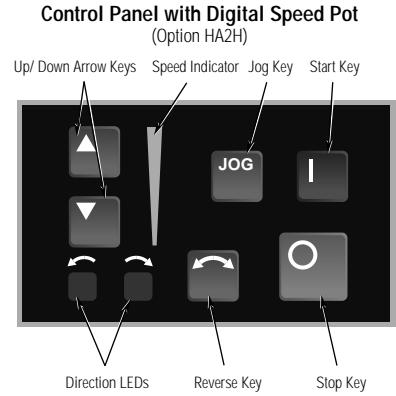
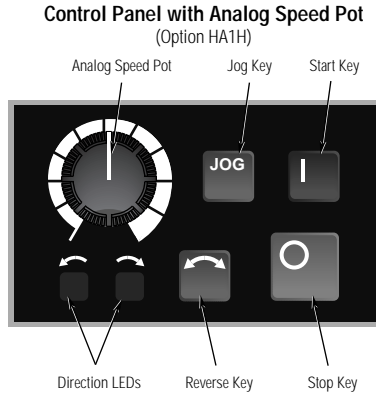
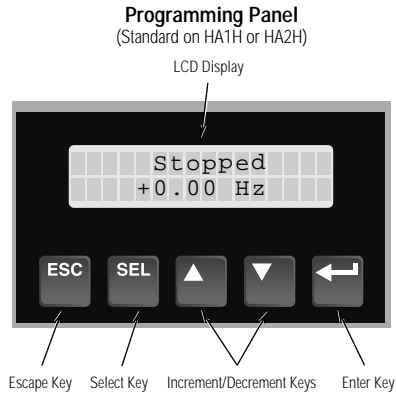

NEMA Type 1 Drive Mounted HIMs

- (Option HNBC)
- (Option HNPC)
- (Option HN1C)
- (Option HN2C)

- Blank — No Functionality
- Program Only
- Program/Control with Analog Speed Pot
- Program/Control with Digital Speed Pot

NEMA Type 1 Door Mounted HIMs

- (Option HABC)
- (Option HAPC)
- (Option HA1C)
- (Option HA2C)

- Blank — No Functionality
- Program Only
- Program/Control with Analog Speed Pot
- Program/Control with Digital Speed Pot

NEMA Type 12 Door Mounted HIMs

- (Option HJPC)
- (Option HJ2C)

- Program Only
- Program/Control with Digital Speed Pot

Handheld

A separate handheld module may be connected to the drive. Maximum cable length is 33 feet (10 meters)

Graphic Programming Terminals — NEMA Type 1 and 12 Door Mounted Graphic Programming Terminals

NEMA Type 1 and 12
(Option HJPEC)

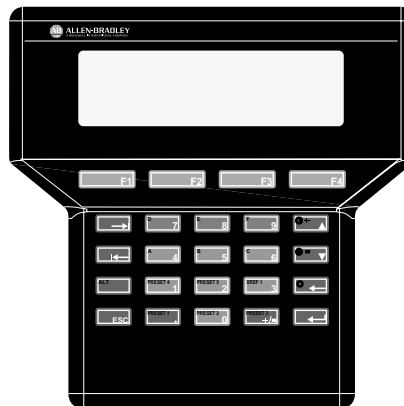

Programmer Only

NEMA Type 1 and 12
(Option HJ3EC)



Programmer/Run Time Functions

Door Mounted Operator Devices

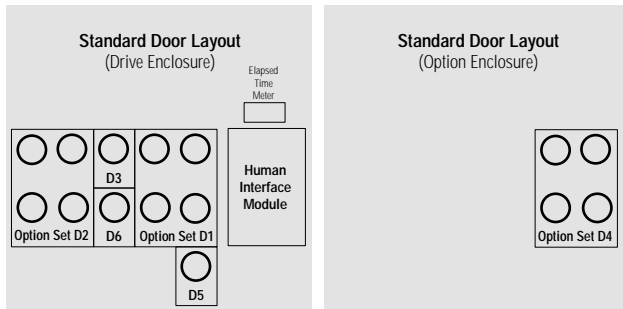

Operator devices specified in the drive catalog number are supplied mounted and wired on the enclosure door. The **Standard Door Layouts** shown indicate the mounting locations of door mounted options or option groups.

The operator device options listed below are logically grouped into sets. Only one option code selection may be made from each set. Where possible, Allen-Bradley Bulletin 800E style operator devices will be supplied.

Description Code: **PB** = Pushbutton **SS** = Selector Switch
PL = Pilot Light **POT** = Potentiometer

Legend plates will be 30 mm × 50 mm, black with white lettering.

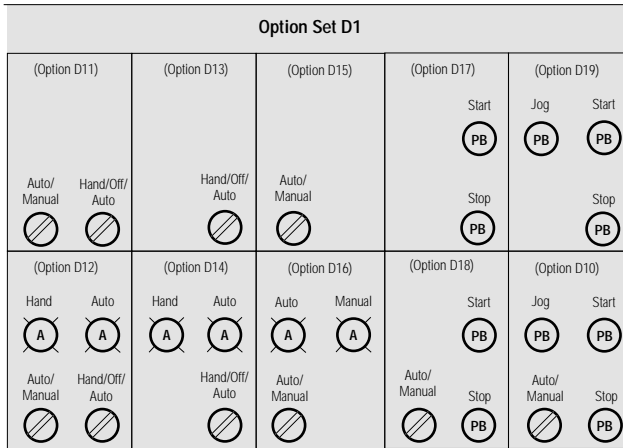

- Option Set D1**
- (Option D10) Start **PB**, Stop **PB**, Jog **PB**, & Auto/Manual **SS**
 - (Option D11) ¹ Hand/Off/Auto (start/stop only) **SS** & Auto/Manual (speed reference only) **SS**
 - (Option D12) ¹ D11 Options plus Hand **PL** & Auto **PL**
 - (Option D13) ¹ Hand/Off/Auto (start/stop/speed ref.) **SS**
 - (Option D14) ¹ D13 Option plus Hand **PL** & Auto **PL**
 - (Option D15) ¹ Auto/Manual (speed reference only) **SS**
 - (Option D16) ¹ D15 Option plus Auto **PL** & Manual **PL**
 - (Option D17) Start **PB** & Stop **PB**
 - (Option D18) Start **PB**, Stop **PB** & Auto/Manual **SS**
 - (Option D19) Start **PB**, Stop **PB** & Jog **PB**

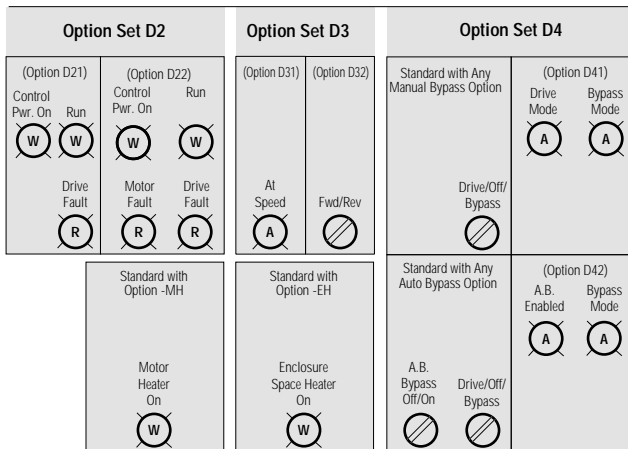

- Option Set D2**
- (Option D21) Control Power On **PL**, Run **PL** & Drive Fault **PL**
 - (Option D22) ² D21 Options plus Motor Fault **PL**
-
- Option Set D3**
- (Option D31) At Speed **PL**
 - (Option D32) Forward/Reverse **SS**
-
- Option Set D4**
- (Option D41) ³ Drive Mode **PL** & Bypass Mode **PL**
 - (Option D42) ⁴ Auto Bypass Enabled On **PL** & Bypass Mode **PL**

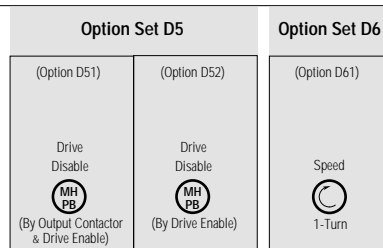

- Option Set D5**
- (Option D51) ⁵ Drive Disable (push-pull) **MHPB**
For Use with Drive Output Contactor & Drive Enable
 - (Option D52) ⁶ Drive Disable (push-pull) **MHPB**
For Use with Drive Enable Only
-
- Option Set D6**
- (Option D61) Speed **POT**, 1-Turn, NEMA Type 1/4/12

¹ Refer to page 39 for Operator Device Function Guide.

² D22 must be used in conjunction with a Thermal Overload or Bypass Option.

³ D41 must be used with a Bypass Option.

⁴ D42 must be used with an Auto Bypass Option.

⁵ D51 must be used in conjunction with an Output Contactor or Bypass Option.

⁶ D52 cannot be used with a Bypass Option.

Option Set D9

- (Option D91) Convert A-B Bulletin 800E Style Operator Devices to A-B Bulletin 800T Style

Operator Device Function Guide

Option	Device Mode	Drive Start and Stop Control			Drive Speed Reference		
		Selector Switch or Pushbutton	Remote Contact	None	Door Mounted or Remote Speed Pot Parameter #5 = 1	Defined by Parameter #6 of Drive ¹	
						None	None
D11 and D12	Hand/Off/Auto	X X					X X X
	Auto/Manual		X	X X	X	X	
D13 and D14	Hand/Off/Auto	X X			X		X
			X			X	
D15 and D16	Start/Stop	X X			X		X X
	Auto/Manual			X X	X	X	

¹ The function of the "Auto Mode" speed reference is dependent upon the programming of Parameter 6 in the drive. The use of an Isolated Signal Conditioner Option -N3 is recommended for any analog signal being fed to the drive.

Meter Options

Custom Analog or Digital Meter
(Option MC)

This option is customer defined and will be supplied and mounted on the enclosure door.

Elapsed Time Meter
(Option ET)

This option provides a digital, non-resettable, elapsed time meter. The meter is electrically interlocked with the drive Run relay and Bypass contactor (if supplied) to indicate actual motor operating hours.

Line Metering System
(Option MQ)

This option provides simultaneous current and voltage metering in one door mounted unit. Each phase can be displayed separately for current or voltage.

Enclosure Options

Voltage Barrier Kit
(Option EB)

Clear plexiglass covers for line side of disconnect switch, door mounted devices above 50V (except for devices with finger safe terminals), and any foreign voltage sources.

Floor Stand
(Option EF1) 12" High
(Option EF2) 24" High

This option converts a wall mounted enclosure to a floor mounted enclosure (adds 12 or 24" to the height of the enclosure).

Nameplate
(Option ET)

6.25" x 2" door mounted white lamacoid nameplate with black letters (message defined by customer at order entry).

Paint
(Option EP)

Special one color (enclosure shell only). A manufacturer's specification number and/or paint chip will be required at order entry.

Space Heater
(Option EH)

Provides (1) enclosure space heater to help prevent condensation inside the enclosure during periods of drive inactivity. Space heater is energized whenever drive power is removed (requires a remote 120V AC power source). Option includes a 180W fin strip type heater and a white Enclosure Space Heater On pilot light mounted on the enclosure door.

Filtered Door Openings Only
(Option EC)

This option provides metal mesh filters on the outside of the enclosure door over all vented openings. This option applies only to NEMA Type 1 frame D, E and G drives.

Gasketed with Filtered Door Openings
(Option EG)

This option provides filtering as described in option EC. In addition all doors and wall panels will be gasketed as necessary to prevent unfiltered air from entering the enclosure.

Language Module Options

(Option ENC)	English/English — Standard on 230 and 460V Drives — Optional on 575V Drives
(Option FRC)	English/French — Standard on 575V Drives — Optional on 230 and 460V Drives
(Option DEC)	English/German — Optional
(Option ITC)	English/Italian — Optional
(Option ESC)	English/Spanish — Optional

Drawing and Test Options

Approval Drawings
 Cat. No. 1301-APPDWG (Black & Whites)
 Cat. No. 1301-APPRV (Velumes)

One set 11" × 17" electrical schematics and enclosure outlines.
Further Engineering and Manufacture of Drive Held Until Drawings Approved and Returned

Manufacturing Drawings
 Cat. No. 1301-MFDWG (Black & Whites)
 Cat. No. 1301-MFRV (Velumes)

One set 11" × 17" electrical schematics and enclosure outlines.
Information Only — Does Not Affect Drive Manufacturing

Final Drawings
 Cat. No. 1301-FINDWG (Black & Whites)
 Cat. No. 1301-FINRV (Velumes)
 Cat. No. 1301-FINRM (Mylar)

One set 11" × 17" electrical schematics and enclosure outlines.
Same Drawings as Shipped With the Configured Drive Instruction Book

Special Drawings and Reports

Cat. No. 1301-TESTR
 Cat. No. 1301-CERMTR
 Cat. No. 1301-CERXFR
 Cat. No. 1301-CERLR

Test Report, Drive Only.
 Certified Motor Dimension Drawing.
 Certified Transformer Dimension Drawing.
 Certified Line Reactor Dimension Drawing — Not Available If Mounted in the Drive Enclosure.

Cat. No. 1301-DISK
 Cat. No. 1301-WT

AutoCAD™ Disk Copy of Order Schematics After Order Has Shipped.
 Witness Test — Customer Viewing of A-B Standard Test Procedures only. Additional tests and documentation per customer requirements are also available.

1336 PLUS CONFIGURED DRIVE PRE-INSTALLATION DATA



ATTENTION: The following information is merely a guide for proper installation. The Allen-Bradley Company cannot assume responsibility for the compliance or the noncompliance to any code, national, local or otherwise for the proper installation of this drive or associated equipment. A hazard of personal injury and/or equipment exists if codes are ignored during installation.



ATTENTION: The drive disable circuitry only shuts off the power transistors or opens an output contactor. Both functions disable inherent or optional dynamic braking effects. If hazards of injury due to contact with moving machinery or unintentional flow of liquid, gas or solids exist, it is the user's responsibility to provide an additional hardwired stop circuit in accordance with applicable codes and standards.

Enclosures

Configured Drives are packaged in NEMA Type 1, 4 or 12 enclosures with the heatsinks mounted out the back. Each enclosure type lends itself to a particular type of protection and environment. Enclosures do not normally protect electrical equipment from condensation, icing, corrosion or contamination which may occur within the enclosure or enter via the conduit or unsealed openings. Users must make adequate provisions to safeguard against such conditions, and satisfy themselves that the equipment is properly protected. For further information on criteria associated with NEMA enclosure ratings, refer to NEMA Standards **Publication Number 250**.

NEMA Type 1 (IP20)

Type 1 enclosures are intended for indoor use primarily to provide a degree of protection against contact with the enclosed equipment in locations where unusual service conditions do not exist. The enclosures are designed to meet the rod entry and rust resistance design tests. Slotted openings in the enclosure sides or door(s) allow for free exchange of inside and outside air.

NEMA Type 12 (IP54)

Type 12 enclosures are intended for indoor use primarily to provide a degree of protection against dust, falling dirt and dripping non-corrosive liquids. They are designed to meet drip, dust and rust resistance tests. There are no ventilation openings within the enclosure to allow free exchange of inside and outside air.

NEMA Type 4 (IP65)

Type 4 enclosures are intended for indoor or outdoor use primarily to provide a degree of protection against windblown dust and rain, splashing water, and hose directed water, and to be undamaged by the formation of ice on the enclosure. They are designed to meet hose-down, dust, external icing and rust resistance design tests. Doors and openings will be gasket sealed. There are no ventilation openings within the enclosure to allow for free exchange of inside and outside air.

Material Specifications

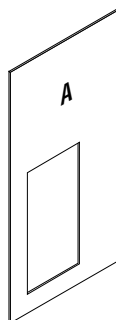
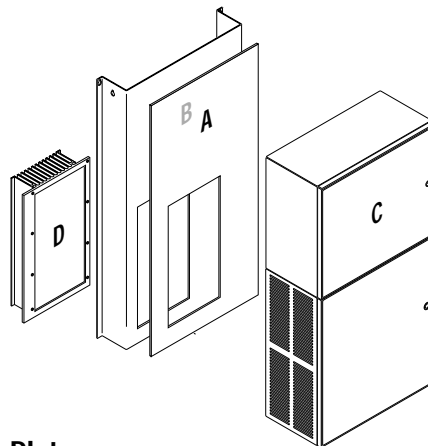

A Drive Base Plate

Frame	Material	Finish	Finish Spec.
A1-A3	14 GA. Sheet Steel	Zinc Plated Yellow Chromate	40001-051-02
A4	14 GA. Sheet Steel	Zinc Plated Yellow Chromate	40001-054-02
B-C	16 GA. Sheet Steel	A-B Standard Light Gray Paint	40001-168-06
D-E	14 GA. Sheet Steel	A-B Standard Light Gray Paint	40001-168-06
G	N/A	N/A	N/A

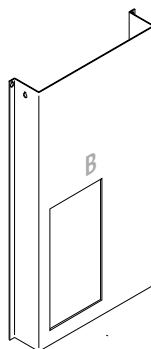

B Back Plate Chassis for Heatsink

Frame	Material	Finish	Finish Spec.
A1-C	12 GA. Sheet Steel	A-B Standard Light Gray Paint	(NEMA Type 1) 40001-109-08 (NEMA Type 4/12) 40001-168-06
D-E	12 GA. Sheet Steel	A-B Standard Light Gray Paint	(NEMA Type 1/12) 40001-109-02
G	0.099 Sheet Steel	A-B Standard Light Gray Paint	(NEMA Type 1/12) 40001-109-02

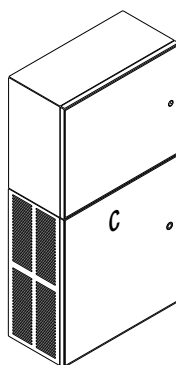

C Enclosure

Frame	Material	Finish	Finish Spec.
A1-C	14 GA. Sheet Steel	A-B Standard Light Gray Paint	(NEMA Type 1) 40001-109-08 (NEMA Type 4/12) 40001-168-06
D-E	0.099. Sheet Steel	A-B Standard Light Gray Paint	(NEMA Type 1/12) 40001-109-02

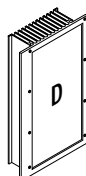

D Heatsink

Frame	Material	Finish	Finish Spec.
A-G	Aluminum	Non-Anodized	N/A

IP20 (NEMA Type 1) 0.37-45kW (0.5-60HP/1.1-77 A) Dimensions

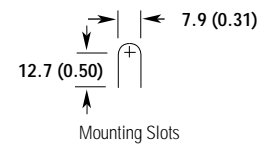
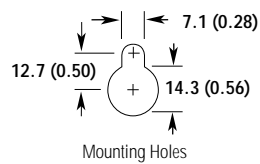
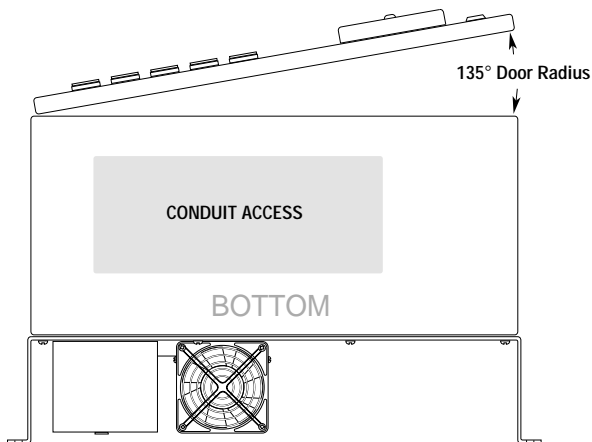
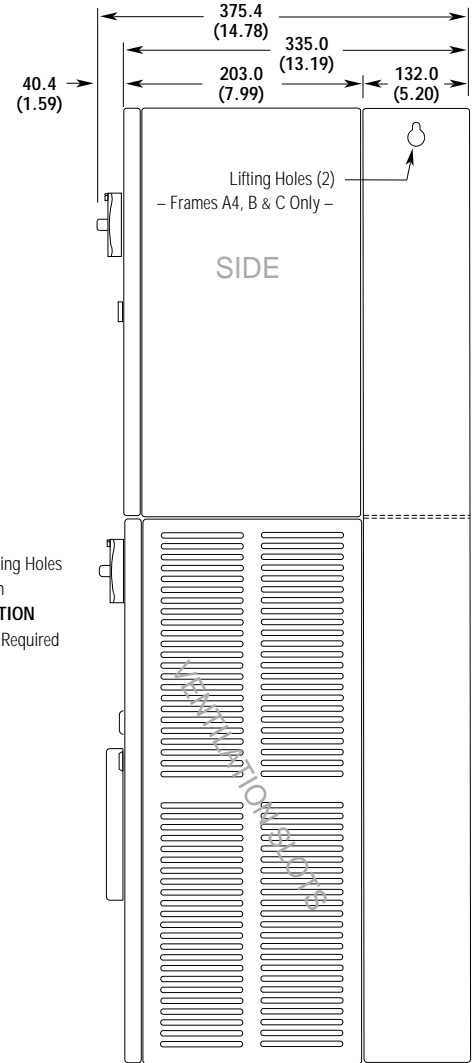
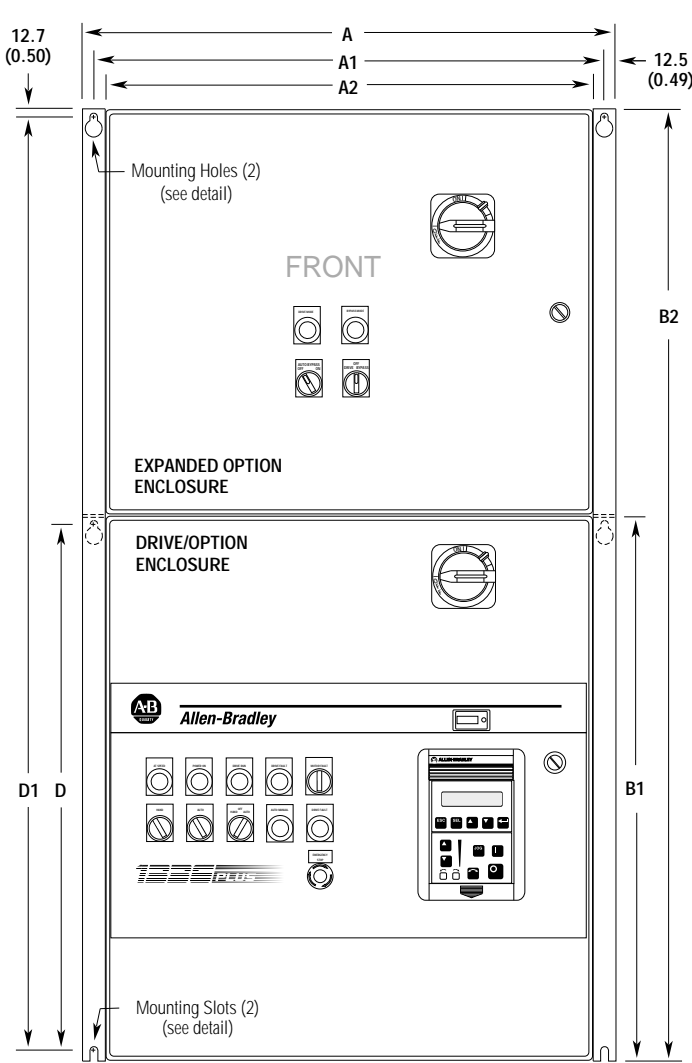

Option Mounting Location

DRIVE/OPTION ENCLOSURE	All Option Codes Not Listed Below
EXPANDED OPTION ENCLOSURE	Option Codes BA, BM, CC, D41, D42, DT, JS
CONSULT FACTORY	Option Codes BC, BD, BP, BS, CM, JL, LQ and LR

Frame	Three-Phase Ratings			All Dimensions in Millimeters and (Inches)							Approximate Shipping Weights	
	230V	460V	575V	A	A1	A2	B1	B2	D	D1	Drive Enclosure Only	Drive and Expanded Option Enclosure
A1-A3	0.37-3.7 kW 0.5-5 HP	0.37-3.7 kW 0.5-5 HP	—	655.0 (25.79)	630.0 (24.80)	600.0 (23.62)	500.0 (19.69)	1000.0 (39.37)	475.0 (18.70)	975.0 (38.39)	35 (75)	65 (140)
A4 or B	5.5-11 kW 7.5-15 HP	5.5-22 kW 7.5-30 HP	5.5-15 kW 7.5-20 HP	655.0 (25.79)	630.0 (24.80)	600.0 (23.62)	650.0 (25.59)	1150.0 (45.28)	625.0 (24.61)	1125.0 (44.29)	60 (130)	110 (243)
C	15-22 kW 20-30 HP	30-45 kW 40-60 HP	19-45 kW 25-60 HP	855.0 (33.66)	830.0 (32.68)	800.0 (31.50)	900.0 (35.43)	1550.0 (61.02)	875.0 (34.45)	1525.0 (60.04)	95 (210)	145 (320)

IP54 (NEMA Type 12) 0.37-45 kW (0.5-60 HP/1.1-77 A) Dimensions

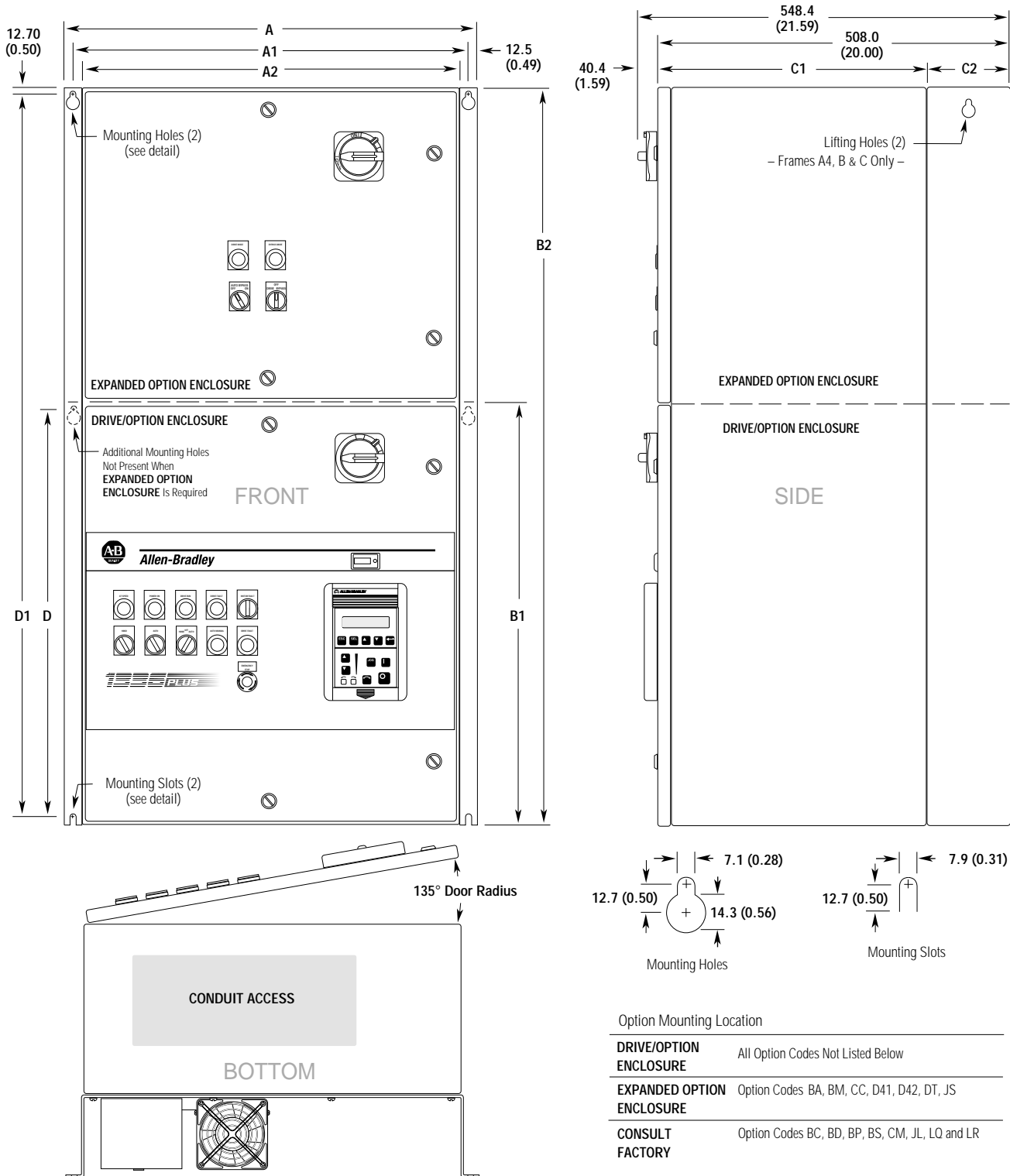

Option Mounting Location

DRIVE/OPTION ENCLOSURE	All Option Codes Not Listed Below
EXPANDED OPTION ENCLOSURE	Option Codes BA, BM, CC, D41, D42, DT, JS
CONSULT FACTORY	Option Codes BC, BD, BP, BS, CM, JL, LQ and LR

Frame	Three-Phase Ratings			All Dimensions in Millimeters and (Inches)								Approximate Shipping Weights		
	230V	460V	575V	A	A1	A2	B1	B2	C1	C2	D	D1	Drive Enclosure Only	Drive and Expanded Option Enclosure
A1-A3	0.37-3.7 kW 0.5-5 HP	0.37-3.7 kW 0.5-5 HP	—	664.7 (26.17)	639.8 (25.19)	609.6 (24.00)	685.8 (27.00)	1193.8 (47.00)	407.9 (16.06)	100.1 (3.94)	660.9 (26.02)	1168.9 (46.02)	50 (110)	79 (175)
A4 or B	5.5-11 kW 7.5-15 HP	5.5-22 kW 7.5-30 HP	0.75-15 kW 1-20 HP	918.7 (36.17)	893.8 (35.19)	863.6 (34.00)	939.8 (37.00)	1549.4 (61.00)	375.9 (14.80)	132.0 (5.20)	914.9 (36.02)	1524.5 (60.02)	77 (170)	129 (285)
C	15-22 kW 20-30 HP	30-45 kW 40-60 HP	19-45 kW 25-60 HP	918.7 (36.17)	893.8 (35.19)	863.6 (34.00)	1320.8 (52.0)	1930.4 (76.0)	375.9 (14.80)	132.0 (5.20)	1295.9 (51.02)	1905.5 (75.02)	116 (255)	166 (365)

IP20 (NEMA Type 1) and IP54 (NEMA Type 12) 45-187 kW (60-250 HP/85-180 A) Dimensions

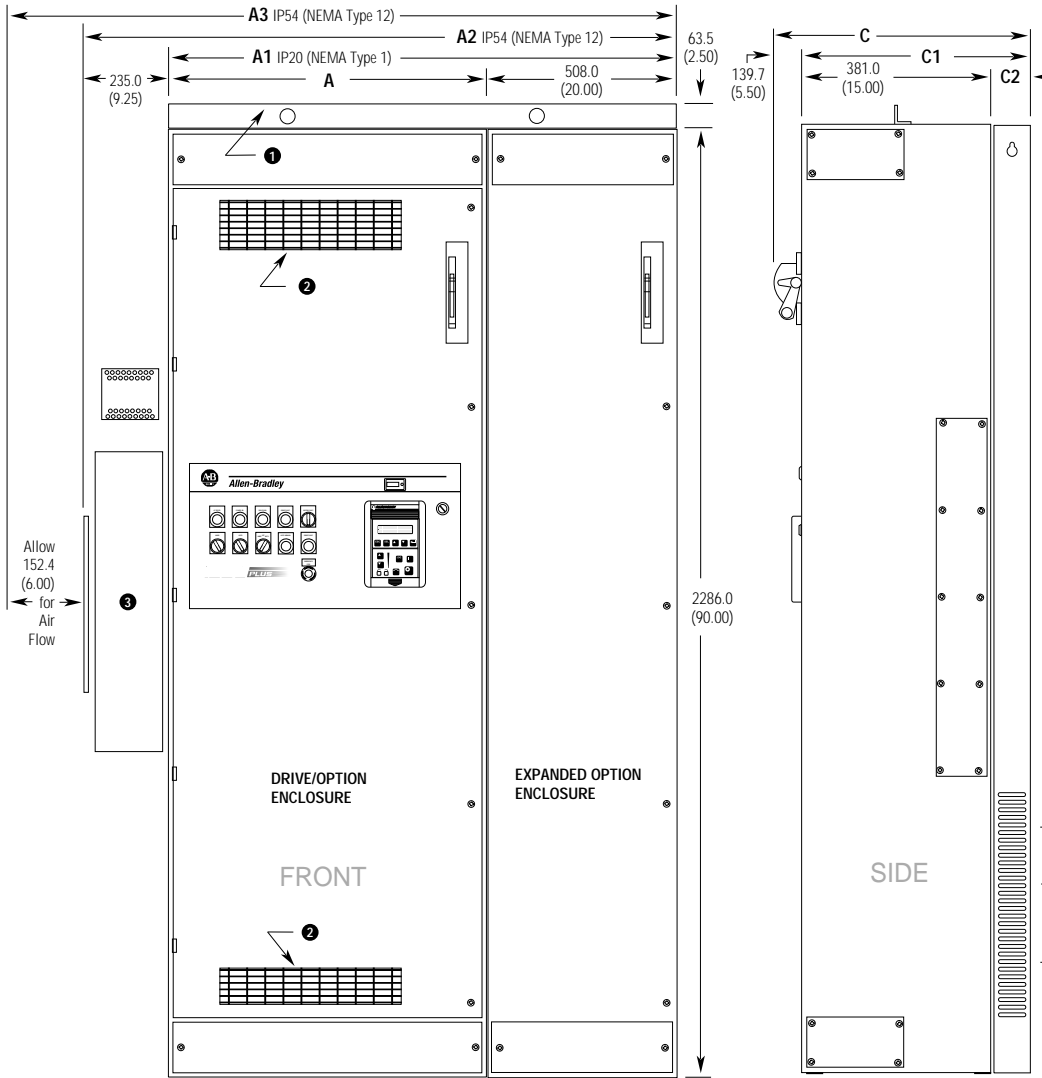

- 1 Removable Lifting Angle
- 2 Vented Areas — IP20 (NEMA Type 1) Only
- 3 Air Conditioner — IP54 (NEMA Type 12) Only
- 4 Heatsink (Fan Accessible from Inside of Enclosure)

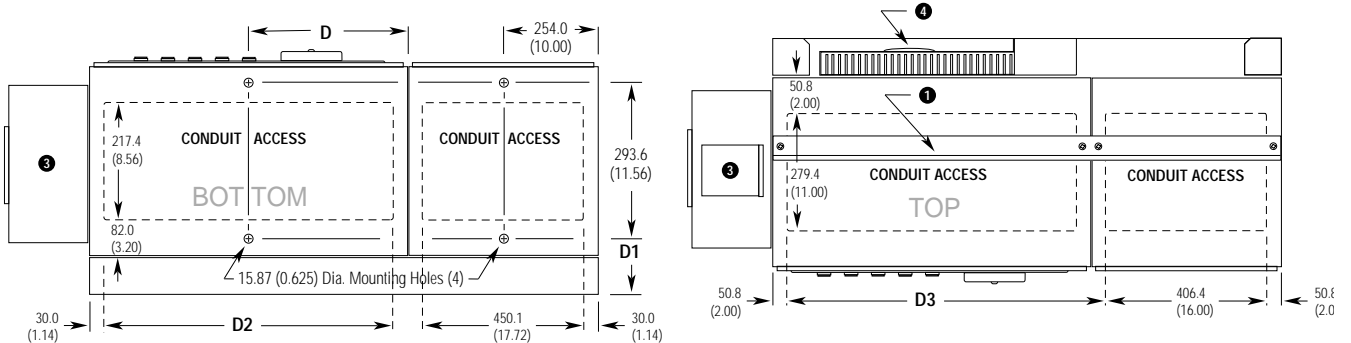

Frame	Three-Phase Ratings			All Dimensions in Millimeters and (Inches) — All Weights in Kilograms and (Pounds)										Approximate Shipping Weights				
	460V-CT	460V-VT	575V	A	A1	A2	A3	C	C1	C2	D	D1	D2	D3	Drive Enclosure Only		Drive & Expanded Enclos.	
	IP20 (NEMA Type 1)	IP54 (NEMA Type 12)	IP54 (NEMA Type 12)	IP20 (NEMA Type 1)	IP20 (NEMA Type 1)	IP54 (NEMA Type 12)	IP54 (NEMA Type 12)	IP20 (NEMA Type 1)	IP20 (NEMA Type 1)	IP54 (NEMA Type 12)	IP20 (NEMA Type 1)	IP54 (NEMA Type 12)	IP20 (NEMA Type 1)	IP54 (NEMA Type 12)	IP20 (NEMA Type 1)	IP54 (NEMA Type 12)		
D	45-112 kW 60-150 HP (85-180 A)	56-112 kW 75-150 HP	56-112 kW 75-150 HP	635.0 (25.00)	1143.0 (45.00)	1378.0 (54.25)	1530.4 (60.25)	607.1 (23.90)	466.1 (18.35)	85.1 (3.35)	317.5 (12.50)	128.0 (5.04)	576.6 (22.70)	533.4 (21.00)	386 (850)	436 (960)	522 (1150)	572 (1260)
E	112-187 kW 150-250 HP (199-325 A)	149-187 kW 200-250 HP	112-149 kW 150-200 HP	889.0 (35.00)	1397.0 (55.00)	1632.0 (64.25)	1784.4 (70.25)	654.1 (25.75)	513.3 (20.21)	132.3 (5.21)	444.5 (17.50)	175.3 (6.90)	830.6 (32.70)	787.4 (31.00)	408 (900)	458 (1010)	544 (1200)	594 (1310)

IP20 (NEMA Type 1) and IP54 (NEMA Type 12) 224-448 kW (300-600 HP) Dimensions for Drives without Bypass

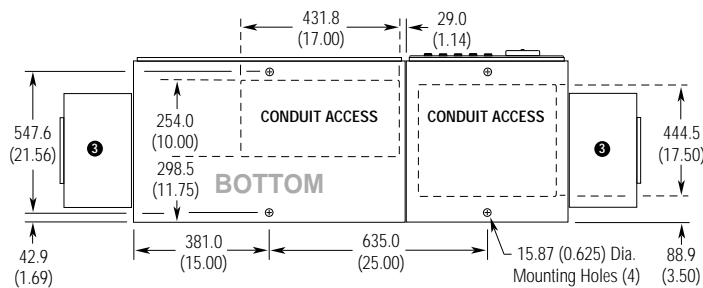
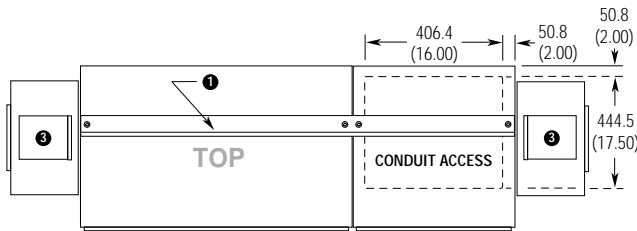
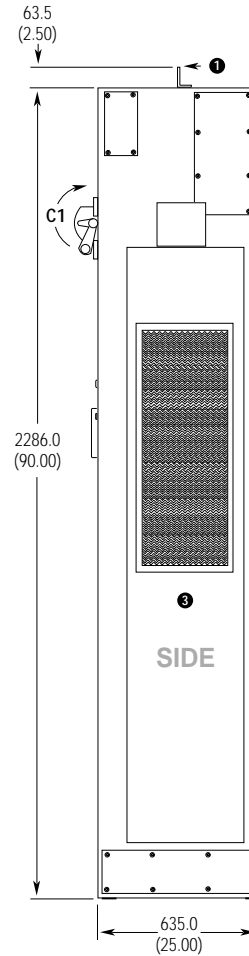
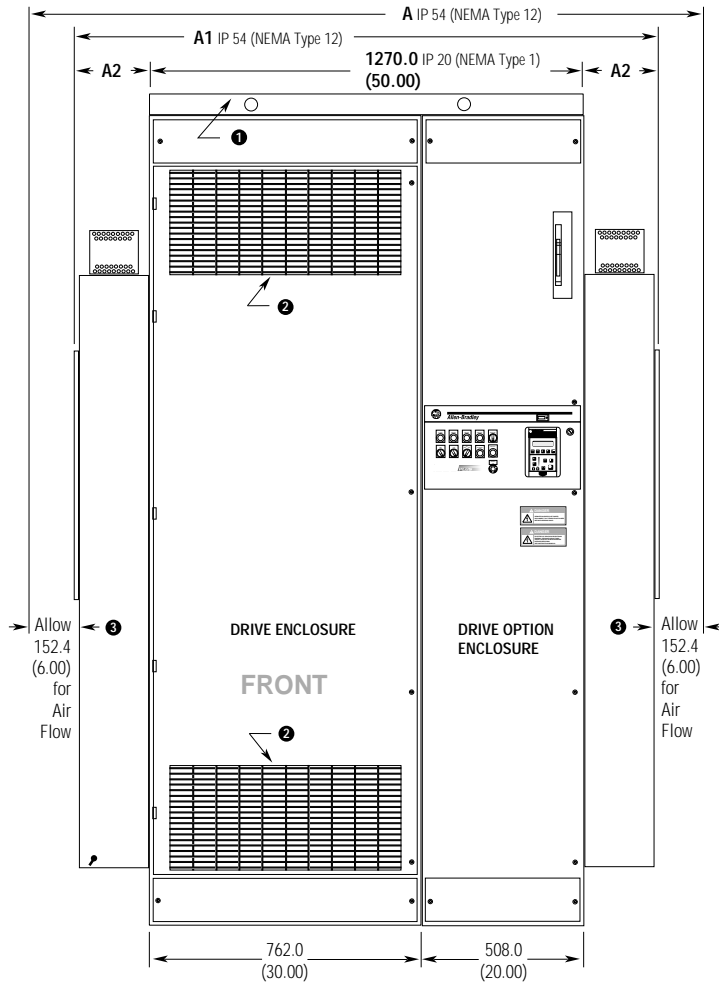

Option Mounting Location

Mountable Option List	CB, CF, CP, CT, DEC, DS, D1_, D2_, D3_, D51, D52, D61, D91, EB, EC, EH, ENC, EP, ESC, ET, FRC, GM1C, GM2C, GM5C, HA_, HJ_, HN_, ITC, JC, JF, JM, JPC, JR, JT, K_, L_, L_, M_, N_, N_
------------------------------	--

Consult Factory Option List	CM, JA, JL, JS, LO, LT, LR, LW
------------------------------------	--------------------------------

Special Smaller Enclosure

A single 762 mm (30 in.) wide enclosure may be used if the option list requirements below are met. Consult factory for custom quotation in all cases.

Any combination of:
 D10-D91, EC, EP, ET, GD1C, GD2C, GM1C, GM2C, GM5C, JC, JF, JM, JR, JT, L4C, L5C, L4EC, L5EC, L6EC, MC, ME, all HIMs and a max. of (1) CF, EB, EH, N2, N3, N4C, N4T, N5C, N5T or N9.

- ① Removable Lifting Angle
- ② Vented Areas — IP20 (NEMA Type 1) Only
- ③ Air Conditioner — IP54 (NEMA Type 12) Only

Frame	Three-Phase Ratings			All Dimensions in Millimeters and (Inches)				Approximate Shipping Weights	
	460V-CT 300-350 HP (360-425 A)	460V-VT 300-350 HP (360-425 A)	575V 300-350 HP (360-425 A)	A	A1	A2	C1	Drive and Expanded Option Enclosure IP 20 (NEMA Type 1)	IP54 (NEMA Type 12)
F-G	224-261 kW 300-350 HP (360-425 A)	224-261 kW 300-350 HP (360-425 A)	224-261 kW 300-350 HP (360-425 A)	2103.1 (82.80)	1798.3 (70.80)	264.2 (10.40)	139.7 (5.50)	624 (1375)	805 (1775)
	298-336 kW 400-450 HP (475-525 A)	298-336 kW 400-450 HP (475-525 A)	298-336 kW 400-450 HP (400-450 A)	2230.1 (87.80)	1925.3 (75.8)	327.7 (12.9)	215.9 (8.50)	624 (1375)	832 (1835)
	373-448 kW 500-600 HP (590-670 A)	373-448 kW 500-600 HP (590-670 A)	373-448 kW 500-600 HP (500-600 A)	Not Available			215.9 (8.50)	624 (1375)	Not Available

IP20 (NEMA Type 1) and IP54 (NEMA Type 12) 224-448 kW (300-600 HP) Dimensions for Drives with Bypass

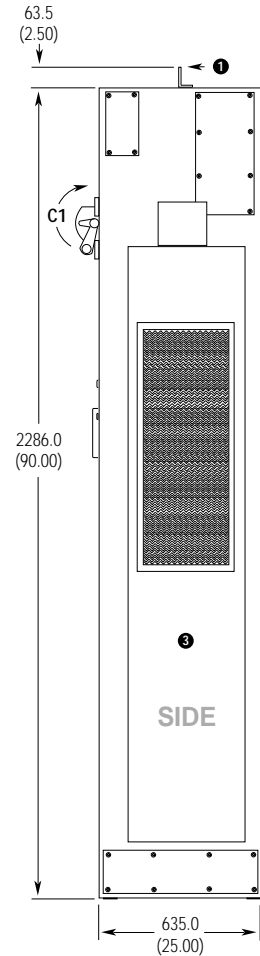
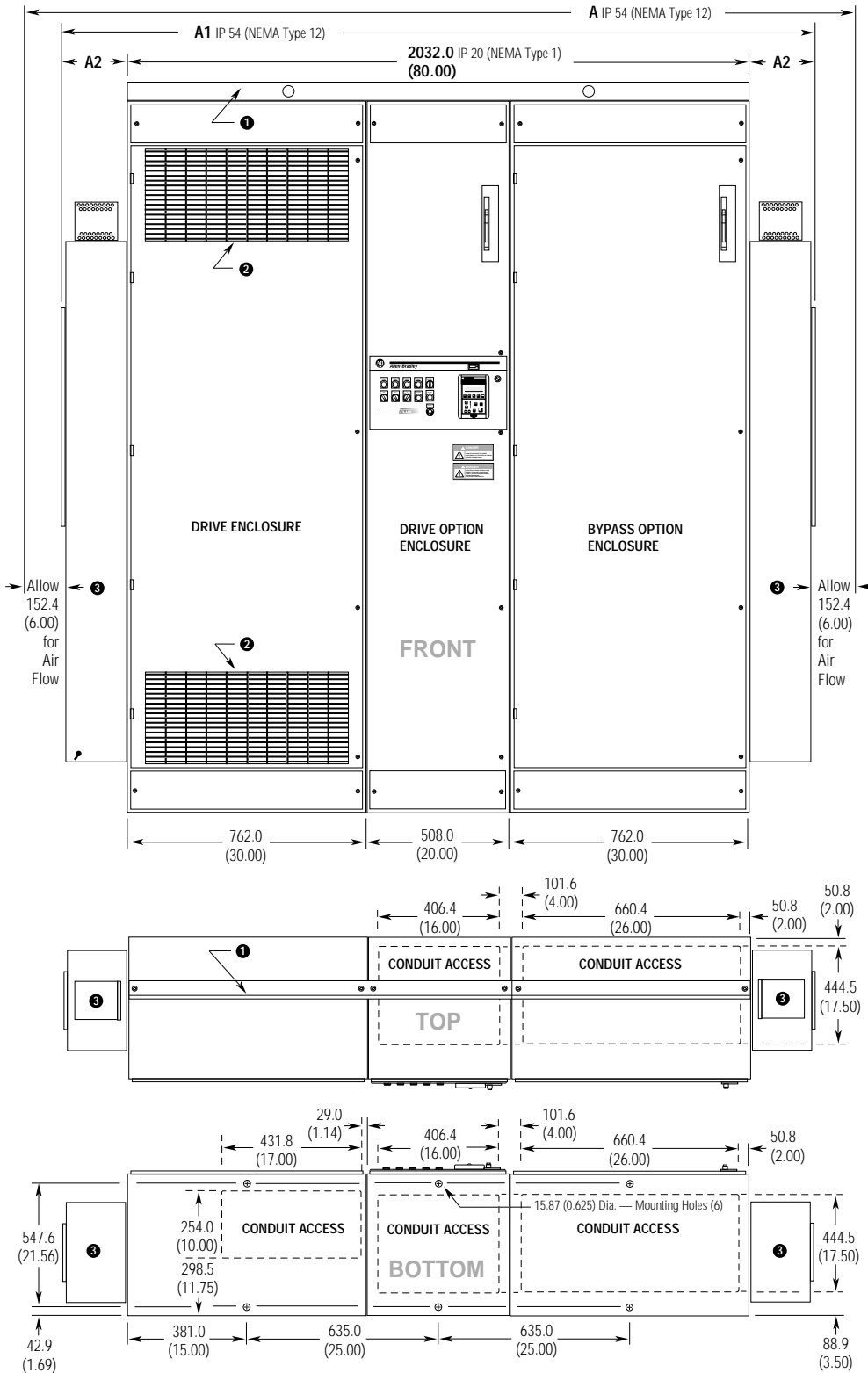

Mountable Option List Option Codes From Previous Page Plus BA, BM, CC, D41, D42, DT, FM

Consult Factory Option List Option Codes From Previous Page Plus BC, BD, BP, BS

- ① Removable Lifting Angle
- ② Vented Areas — IP20 (NEMA Type 1) Only
- ③ Air Conditioner — IP54 (NEMA Type 12) Only

Approximate Shipping Weights
Drive and Expanded Option Enclosure
 IP 20 (NEMA Type 1) IP54 (NEMA Type 12)

Frame	Three-Phase Ratings			All Dimensions in Millimeters and (Inches)				All Weights in Kilograms and (Pounds)	
	460V-CT	460V-VT	575V	A	A1	A2	C1	IP 20 (NEMA Type 1)	IP54 (NEMA Type 12)
F-G	224-261 kW 300-350 HP (360-425 A)	224-261 kW 300-350 HP (360-425 A)	224-261 kW 300-350 HP (360-425 A)	2865.1 (112.80)	2560.3 (100.80)	264.2 (10.40)	139.7 (5.50)	1066 (2350)	1247 (2750)
	298-336 kW 400-450 HP (475-525 A)	298-336 kW 400-450 HP (475-525 A)	298-336 kW 400-450 HP (400-450 A)	2992.1 (117.80)	2687.3 (105.80)	327.7 (12.90)	215.9 (8.50)	1066 (2350)	1275 (2810)
	373-448 kW 500-600 HP (590-670 A)	373-448 kW 500-600 HP (590-670 A)	373-448 kW 500-600 HP (500-600 A)	Not Available			215.9 (8.50)	1066 (2350)	Not Available

Panel Layouts — 230/460V 0.37-3.7 kW (0.5-5 HP)

The panel layout shown below is typical for the drive ratings listed. The layout includes a worst case P Options scenario. The dimension grid can be used to determine available panel space by taking into account which of the components shown will actually be included in an individual drive package.

A1-A3 Frame Drives
IP20 (NEMA Type 1)

with Option Bay

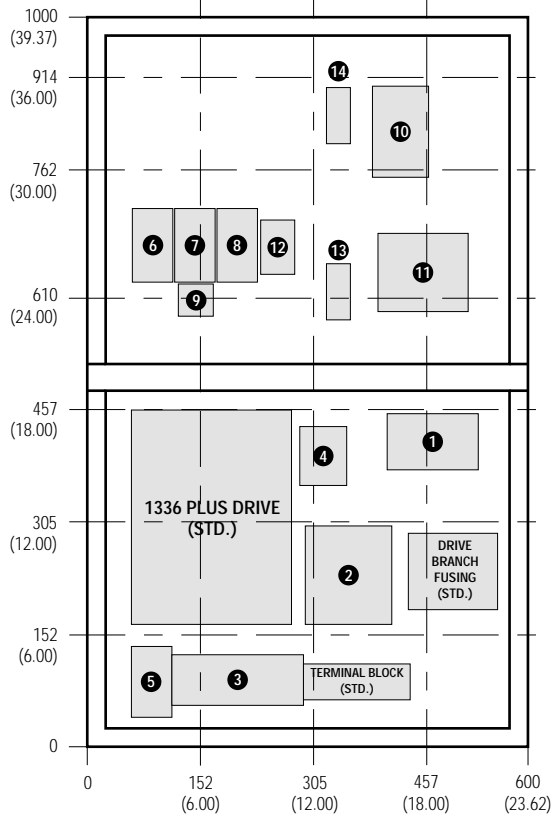

without Option Bay

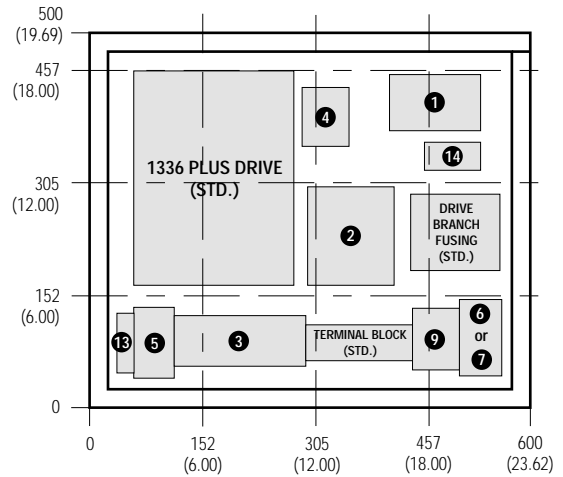

All Dimensions in Millimeters and (Inches)

- | | |
|--|---|
| ① DRIVE CIRCUIT BREAKER OR DISCONNECT SWITCH | ⑧ BYPASS CONTACTOR |
| ② CONTROL TRANSFORMER | ⑨ OVERLOAD RELAY |
| ③ RELAY LOGIC (VARIES) | ⑩ BYPASS CIRCUIT BREAKER OR DISCONNECT SWITCH |
| ④ COMMUNICATION OPTION CARD | ⑪ BYPASS MOTOR FUSES |
| ⑤ INPUT AND OUTPUT ISOLATORS | ⑫ BYPASS LOGIC |
| ⑥ DRIVE INPUT CONTACTOR | ⑬ MOTOR GROUND TERMINAL |
| ⑦ DRIVE OUTPUT CONTACTOR | ⑭ DRIVE GROUND TERMINAL |

Panel Layouts — 230/460V 0.37-3.7 kW (0.5-5 HP)

The panel layout shown below is typical for the drive ratings listed. The layout includes a worst case P Options scenario. The dimension grid can be used to determine available panel space by taking into account which of the components shown will actually be included in an individual drive package. Consult Allen-Bradley when adding additional heat producing components to existing NEMA Type 4 or 12 rated drives.

A1-A3 Frame Drives
IP54 (NEMA Type 12)

with Option Bay

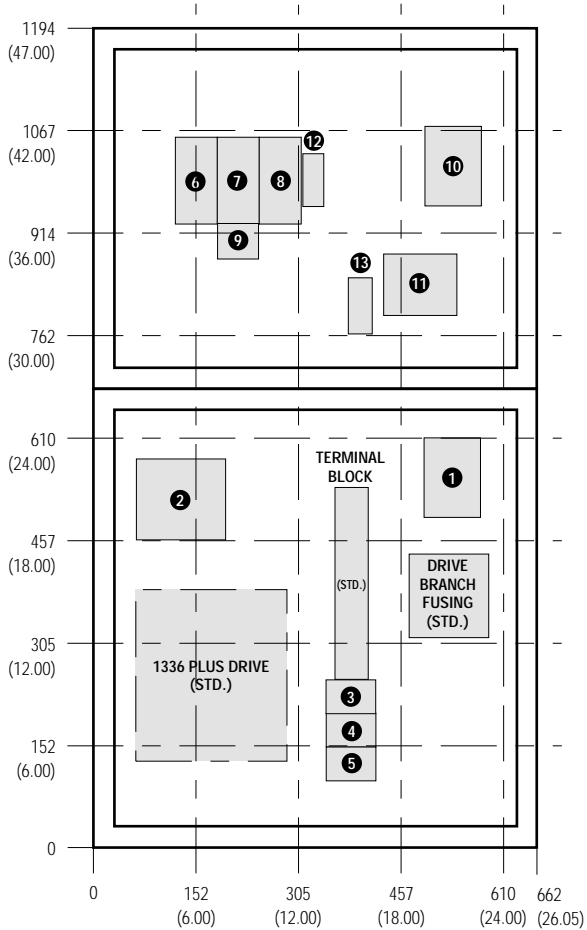

without Option Bay

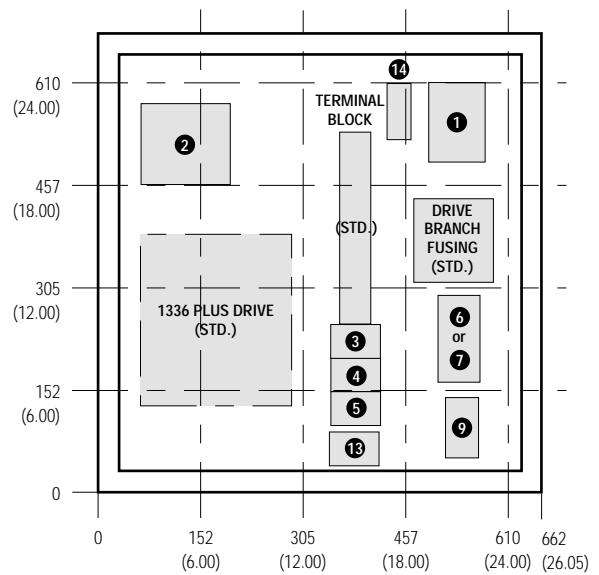

All Dimensions in Millimeters and (Inches)

- | | |
|--|---|
| ① DRIVE CIRCUIT BREAKER OR DISCONNECT SWITCH | ⑧ BYPASS CONTACTOR |
| ② CONTROL TRANSFORMER | ⑨ OVERLOAD RELAY |
| ③ RELAY LOGIC (VARIES) | ⑩ BYPASS CIRCUIT BREAKER OR DISCONNECT SWITCH |
| ④ COMMUNICATION OPTION CARD | ⑪ BYPASS MOTOR FUSES |
| ⑤ INPUT AND OUTPUT ISOLATORS | ⑫ BYPASS LOGIC |
| ⑥ DRIVE INPUT CONTACTOR | ⑬ MOTOR GROUND TERMINAL |
| ⑦ DRIVE OUTPUT CONTACTOR | ⑭ DRIVE GROUND TERMINAL |

Panel Layouts — 460V 5.5-11 kW (7.5-15HP) — 575V .75-3.7 kW (1-5HP)

The panel layout shown below is typical for the drive ratings listed. The layout includes a worst case P Options scenario. The dimension grid can be used to determine available panel space by taking into account which of the components shown will actually be included in an individual drive package.

A4 Frame Drives
IP20 (NEMA Type 1)

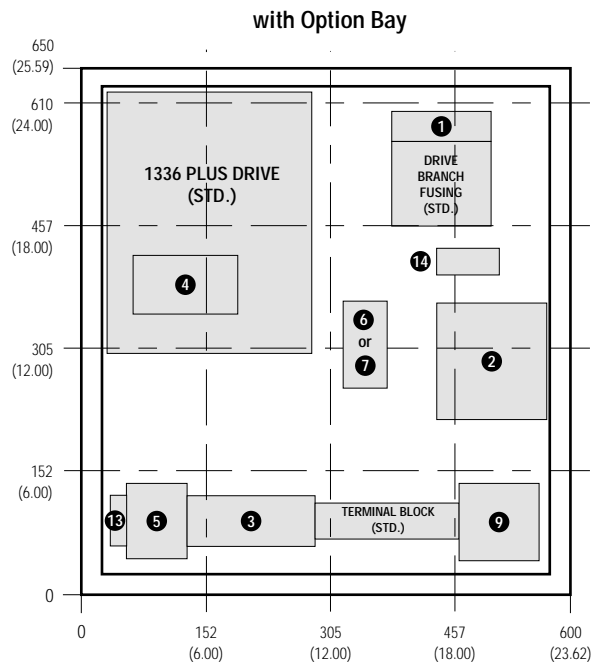
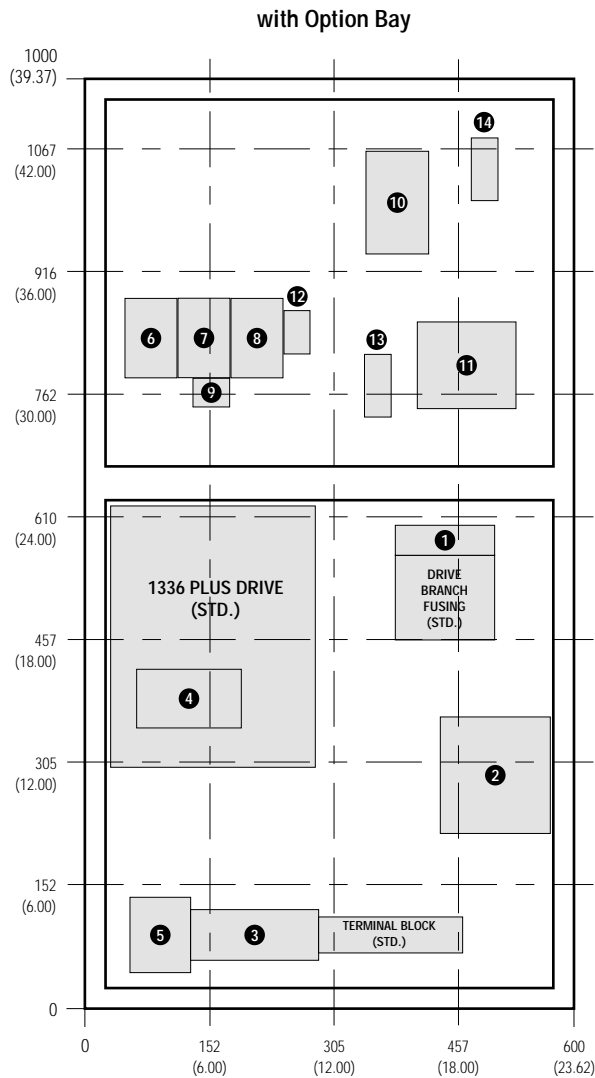

All Dimensions in Millimeters and (Inches)

- | | |
|--|---|
| ① DRIVE CIRCUIT BREAKER OR DISCONNECT SWITCH | ⑧ BYPASS CONTACTOR |
| ② CONTROL TRANSFORMER | ⑨ OVERLOAD RELAY |
| ③ RELAY LOGIC (VARIES) | ⑩ BYPASS CIRCUIT BREAKER OR DISCONNECT SWITCH |
| ④ COMMUNICATION OPTION CARD | ⑪ BYPASS MOTOR FUSES |
| ⑤ INPUT AND OUTPUT ISOLATORS | ⑫ BYPASS LOGIC |
| ⑥ DRIVE INPUT CONTACTOR | ⑬ MOTOR GROUND TERMINAL |
| ⑦ DRIVE OUTPUT CONTACTOR | ⑭ DRIVE GROUND TERMINAL |

Panel Layouts — 230V 5.5-11 kW (7.5-15 HP) — 460V 5.5-22 kW (7.5-30 HP) — 575V 5.5-15 kW (7.5-20 HP)

The panel layout shown below is typical for the drive ratings listed. The layout includes a worst case P Options scenario. The dimension grid can be used to determine available panel space by taking into account which of the components shown will actually be included in an individual drive package.

B1-B2 Frame Drives
IP20 (NEMA Type 1)

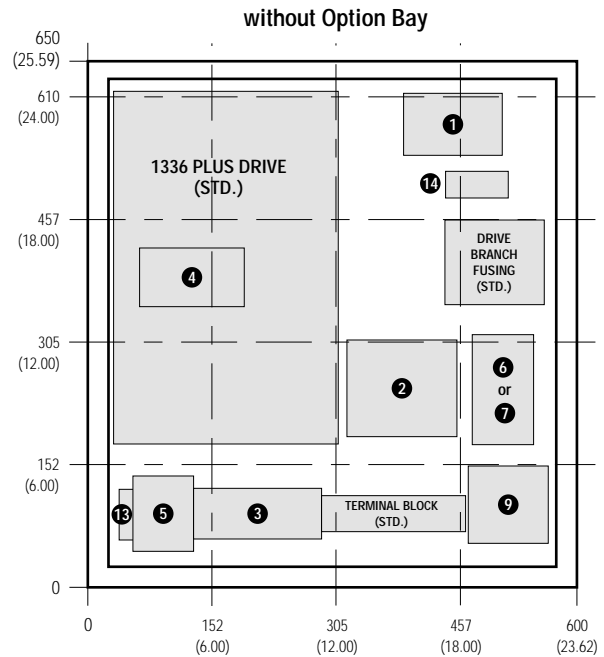
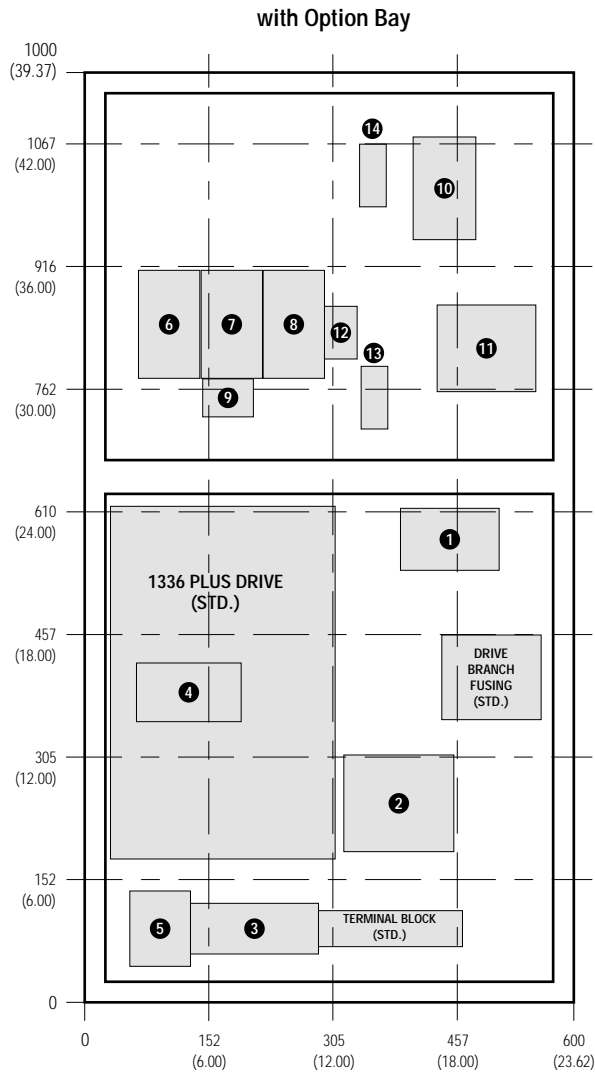

All Dimensions in Millimeters and (Inches)

- | | |
|--|---|
| ① DRIVE CIRCUIT BREAKER OR DISCONNECT SWITCH | ⑧ BYPASS CONTACTOR |
| ② CONTROL TRANSFORMER | ⑨ OVERLOAD RELAY |
| ③ RELAY LOGIC (VARIES) | ⑩ BYPASS CIRCUIT BREAKER OR DISCONNECT SWITCH |
| ④ COMMUNICATION OPTION CARD | ⑪ BYPASS MOTOR FUSES |
| ⑤ INPUT AND OUTPUT ISOLATORS | ⑫ BYPASS LOGIC |
| ⑥ DRIVE INPUT CONTACTOR | ⑬ MOTOR GROUND TERMINAL |
| ⑦ DRIVE OUTPUT CONTACTOR | ⑭ DRIVE GROUND TERMINAL |

Panel Layouts — 230V 5.5-11 kW (7.5-15 HP) — 460V 5.5-22 kW (7.5-30 HP) — 575V .75-15 kW (1-20 HP)

The panel layout shown below is typical for the drive ratings listed. The layout includes a worst case P Options scenario. The dimension grid can be used to determine available panel space by taking into account which of the components shown will actually be included in an individual drive package. Consult Allen-Bradley when adding additional heat producing components to existing NEMA Type 12 rated drives.

A4, B1 and B2 Frame Drives
IP54 (NEMA Type 12)



All Dimensions in Millimeters and (Inches)

- ① DRIVE CIRCUIT BREAKER OR DISCONNECT SWITCH
- ② CONTROL TRANSFORMER
- ③ RELAY LOGIC (VARIES)
- ④ COMMUNICATION OPTION CARD (A4 or B Frame)
- ⑤ INPUT AND OUTPUT ISOLATORS
- ⑥ DRIVE INPUT CONTACTOR
- ⑦ DRIVE OUTPUT CONTACTOR
- ⑧ BYPASS CONTACTOR
- ⑨ OVERLOAD RELAY
- ⑩ BYPASS CIRCUIT BREAKER OR DISCONNECT SWITCH
- ⑪ BYPASS MOTOR FUSES
- ⑫ BYPASS LOGIC
- ⑬ MOTOR GROUND TERMINAL
- ⑭ LINE GROUND TERMINAL
- ⑮ COMMUNICATION OPTION CARD (B Frame Only)

Panel Layouts — 230V 15-22kW (20-30 HP) — 460V 30-45kW (40-60 HP) — 575V 18.5-45kW (25-60 HP)

The panel layout shown below is typical for the drive ratings listed. The layout includes a worst case P Options scenario. The dimension grid can be used to determine available panel space by taking into account which of the components shown will actually be included in an individual drive package.

C Frame Drives
IP20 (NEMA Type 1)

with Option Bay

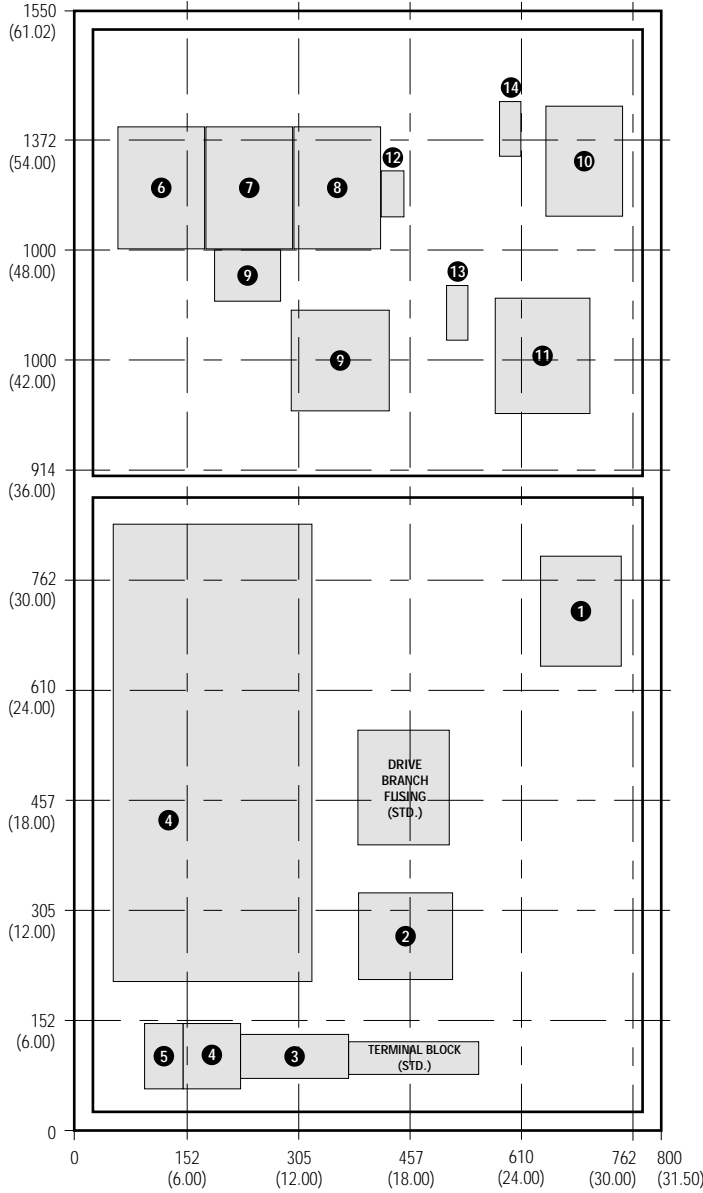

without Option Bay

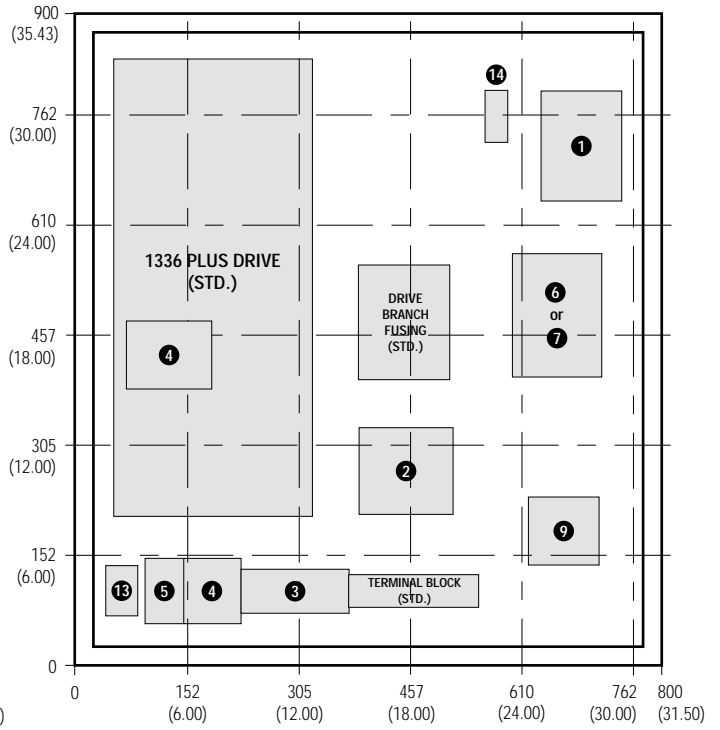

All Dimensions in Millimeters and (Inches)

- | | |
|--|---|
| ① DRIVE CIRCUIT BREAKER OR DISCONNECT SWITCH | ⑧ BYPASS CONTACTOR |
| ② CONTROL TRANSFORMER | ⑨ OVERLOAD RELAY |
| ③ RELAY LOGIC (VARIES) | ⑩ BYPASS CIRCUIT BREAKER OR DISCONNECT SWITCH |
| ④ COMMUNICATION OPTION CARD — DRIVE OR PANEL MOUNTED | ⑪ BYPASS MOTOR FUSES |
| ⑤ INPUT AND OUTPUT ISOLATORS | ⑫ BYPASS LOGIC |
| ⑥ DRIVE INPUT CONTACTOR | ⑬ MOTOR GROUND TERMINAL |
| ⑦ DRIVE OUTPUT CONTACTOR | ⑭ LINE GROUND TERMINAL |

Panel Layouts — 230V 15-22 kW (20-30 HP) — 460V 30-45 kW (40-60 HP) — 575V 18.5-45 kW (25-60 HP)

The panel layout shown below is typical for the drive ratings listed. The layout includes a worst case P Options scenario. The dimension grid can be used to determine available panel space by taking into account which of the components shown will actually be included in an individual drive package. Consult Allen-Bradley when adding additional heat producing components to existing NEMA Type 4 or 12 rated drives.

C Frame Drive
IP54 (NEMA Type 12)

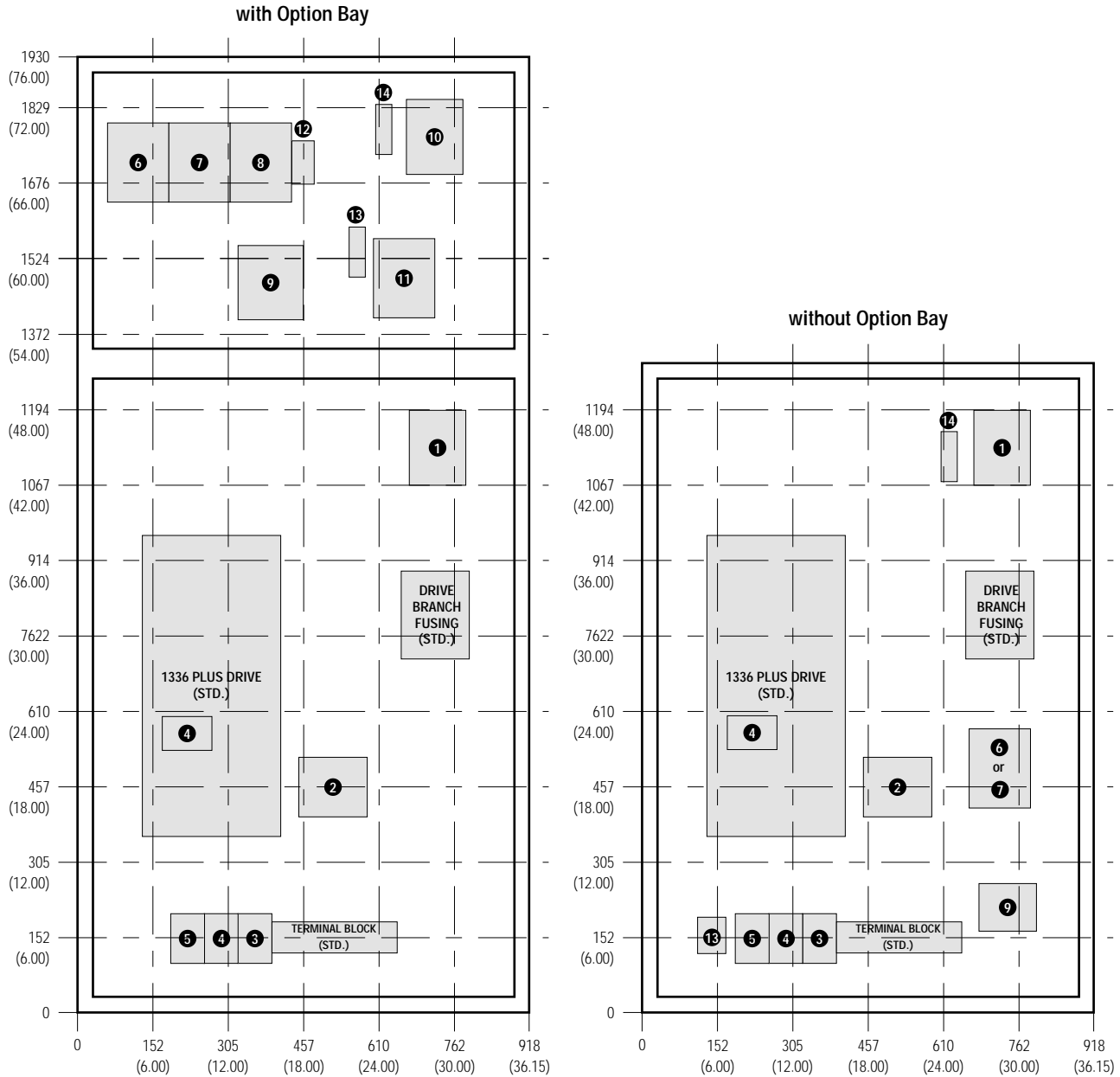

All Dimensions in Millimeters and (Inches)

- | | |
|--|---|
| ① DRIVE CIRCUIT BREAKER OR DISCONNECT SWITCH | ⑧ BYPASS CONTACTOR |
| ② CONTROL TRANSFORMER | ⑨ OVERLOAD RELAY |
| ③ RELAY LOGIC (VARIES) | ⑩ BYPASS CIRCUIT BREAKER OR DISCONNECT SWITCH |
| ④ COMMUNICATION OPTION CARD — DRIVE OR PANEL MOUNTED | ⑪ BYPASS MOTOR FUSES |
| ⑤ INPUT AND OUTPUT ISOLATORS | ⑫ BYPASS LOGIC |
| ⑥ DRIVE INPUT CONTACTOR | ⑬ MOTOR GROUND TERMINAL |
| ⑦ DRIVE OUTPUT CONTACTOR | ⑭ LINE GROUND TERMINAL |

Panel Layouts — 230V 30-45 kW (40-60 HP) — 460V 45-112 kW (60-150 HP @ 180A) — 575V 56-93 kW (75-125 HP)

The panel layout shown below is typical for the drive ratings listed. The layout includes a worst case P Options scenario. The dimension grid can be used to determine available panel space by taking into account which of the components shown will actually be included in an individual drive package. Consult Allen-Bradley when adding additional heat producing components to existing NEMA Type 12 rated drives.

D Frame Drives
IP20 or IP54 (NEMA Type 1 or NEMA Type 12)

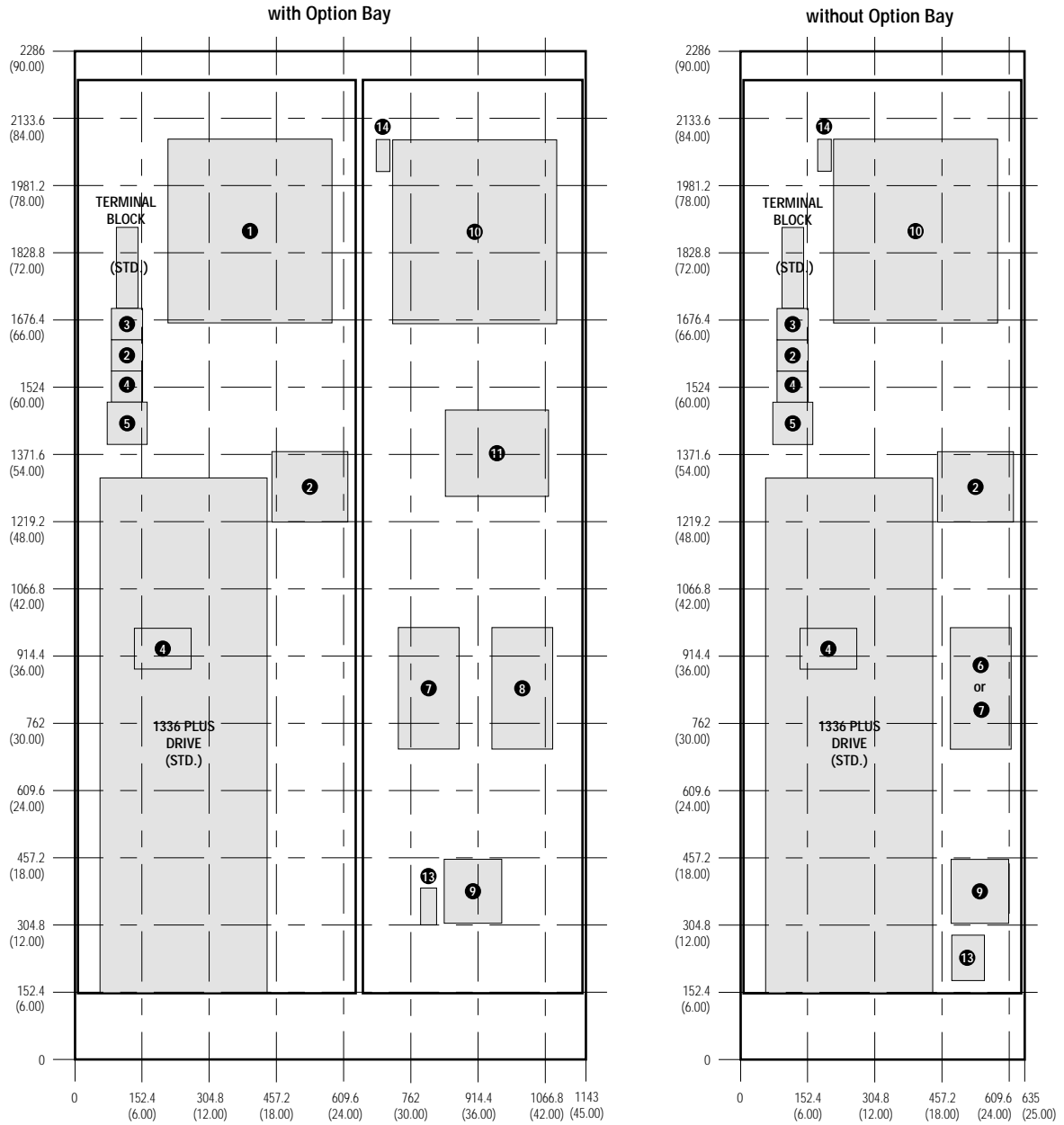

All Dimensions in Millimeters and (Inches)

- | | |
|---|---|
| ① DRIVE CIRCUIT BREAKER OR DISCONNECT SWITCH | ⑧ BYPASS CONTACTOR |
| ② CONTROL TRANSFORMER | ⑨ OVERLOAD RELAY |
| ③ RELAY LOGIC (VARIES) | ⑩ BYPASS CIRCUIT BREAKER OR DISCONNECT SWITCH |
| ④ COMMUNICATION OPTION CARD — DRIVE OR OPTION MOUNTED | ⑪ BYPASS MOTOR FUSES |
| ⑤ INPUT AND OUTPUT ISOLATORS | ⑫ BYPASS LOGIC |
| ⑥ DRIVE INPUT CONTACTOR | ⑬ MOTOR GROUND TERMINAL |
| ⑦ DRIVE OUTPUT CONTACTOR | ⑭ LINE GROUND TERMINAL |

Panel Layouts — 230V 56-93 kW (75-125 HP) — 460V 112-187 kW (150 @ 199A-250 HP) — 575V 112-224 kW (150-300 HP)

The panel layout shown below is typical for the drive ratings listed. The layout includes a worst case P Options scenario. The dimension grid can be used to determine available panel space by taking into account which of the components shown will actually be included in an individual drive package. Consult Allen-Bradley when adding additional heat producing components to existing NEMA Type 12 rated drives.

E Frame Drives
IP20 or IP54 (NEMA Type 1 or NEMA Type 12)

with Option Bay

without Option Bay

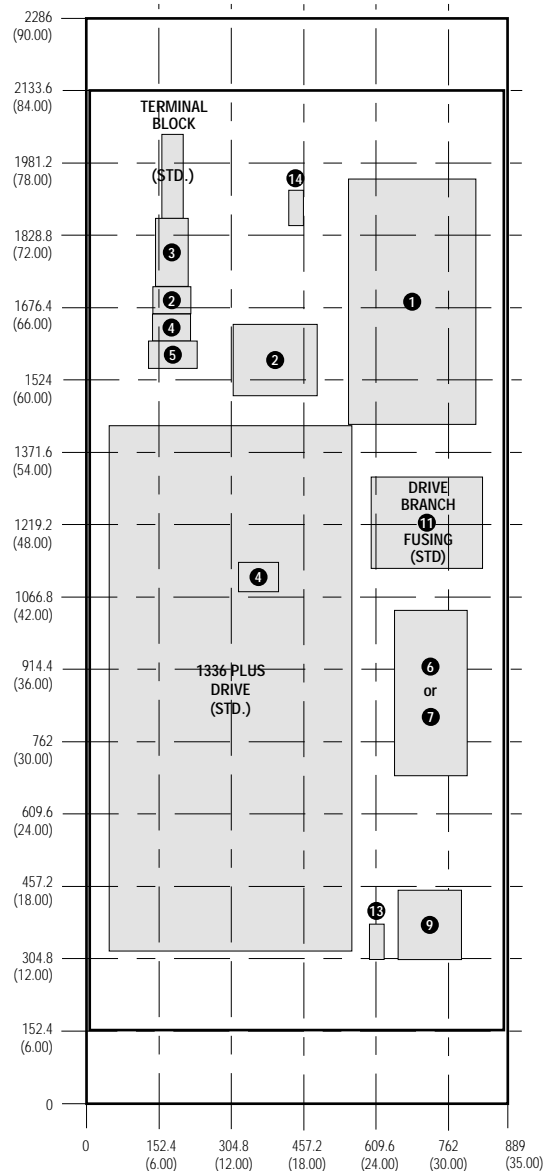
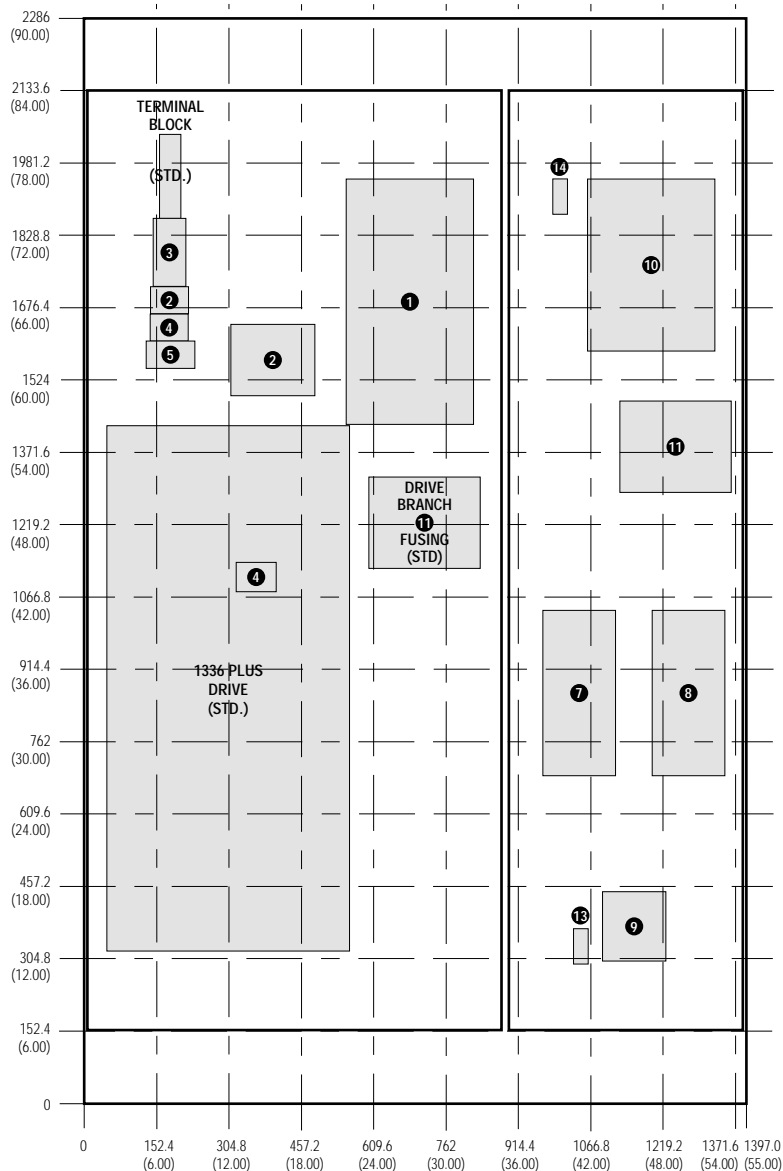

All Dimensions in Millimeters and (Inches)

- 1 DRIVE CIRCUIT BREAKER OR DISCONNECT SWITCH
- 2 CONTROL TRANSFORMER
- 3 RELAY LOGIC (VARIES)
- 4 COMMUNICATION OPTION CARD — DRIVE OR OPTION MOUNTED
- 5 INPUT AND OUTPUT ISOLATORS
- 6 DRIVE INPUT CONTACTOR
- 7 DRIVE OUTPUT CONTACTOR
- 8 BYPASS CONTACTOR
- 9 OVERLOAD RELAY
- 10 BYPASS CIRCUIT BREAKER OR DISCONNECT SWITCH
- 11 BYPASS MOTOR FUSES
- 12 BYPASS LOGIC
- 13 MOTOR GROUND TERMINAL
- 14 LINE GROUND TERMINAL

Panel Layouts — 460V 187-448 kW (250-600 HP) — 575V 224-448 kW (300-600 HP)

The panel layout shown below is typical for the drive ratings listed. The layout includes a worst case P Options scenario. The dimension grid can be used to determine available panel space by taking into account which of the components shown will actually be included in an individual drive package. Consult Allen-Bradley when adding additional heat producing components to existing NEMA Type 12 rated drives.

F-G Frame Drives
IP20 or IP54 (NEMA Type 1 or NEMA Type 12)¹

2-Bay without Bypass

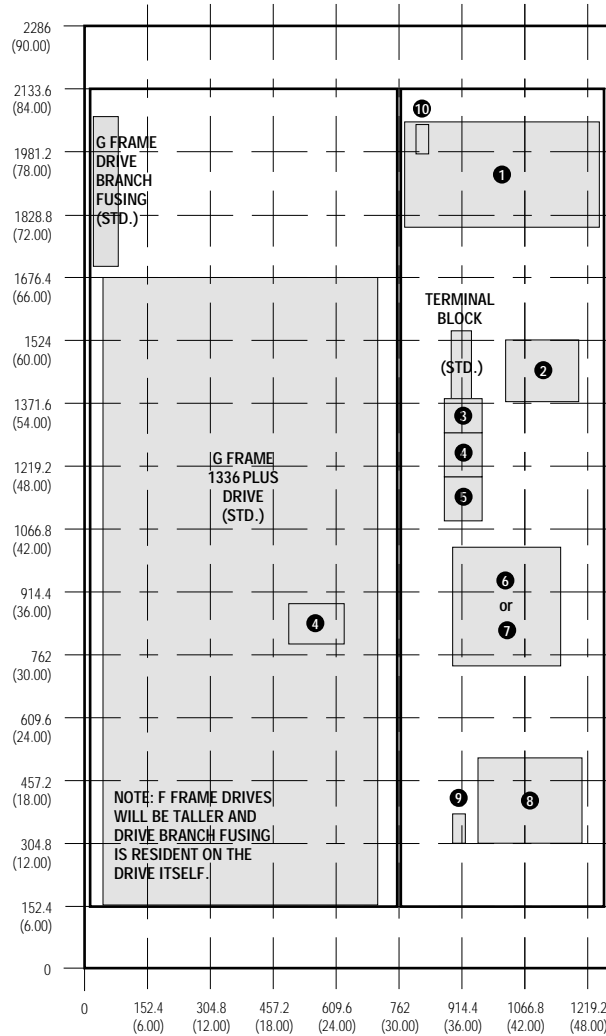

All Dimensions in Millimeters and (Inches)

- | | |
|--|--------------------------|
| ① DRIVE CIRCUIT BREAKER OR DISCONNECT SWITCH | ⑥ DRIVE INPUT CONTACTOR |
| ② CONTROL TRANSFORMER | ⑦ DRIVE OUTPUT CONTACTOR |
| ③ RELAY LOGIC (VARIES) | ⑧ OVERLOAD RELAY |
| ④ COMMUNICATION OPTION CARD — DRIVE OR PANEL MOUNTED | ⑨ MOTOR GROUND TERMINAL |
| ⑤ INPUT AND OUTPUT ISOLATORS | ⑩ LINE GROUND TERMINAL |

¹ Not all ratings are available NEMA Type 12

Panel Layouts — 460V 187-448 kW (250-600 HP) — 575V 224-448 kW (300-600 HP)

The panel layout shown below is typical for the drive ratings listed. The layout includes a worst case P Options scenario. The dimension grid can be used to determine available panel space by taking into account which of the components shown will actually be included in an individual drive package. Consult Allen-Bradley when adding additional heat producing components to existing NEMA Type 12 rated drives.

F-G Frame Drives
IP20 or IP54 (NEMA Type 1 or NEMA Type 12)¹

3-Bay with Bypass

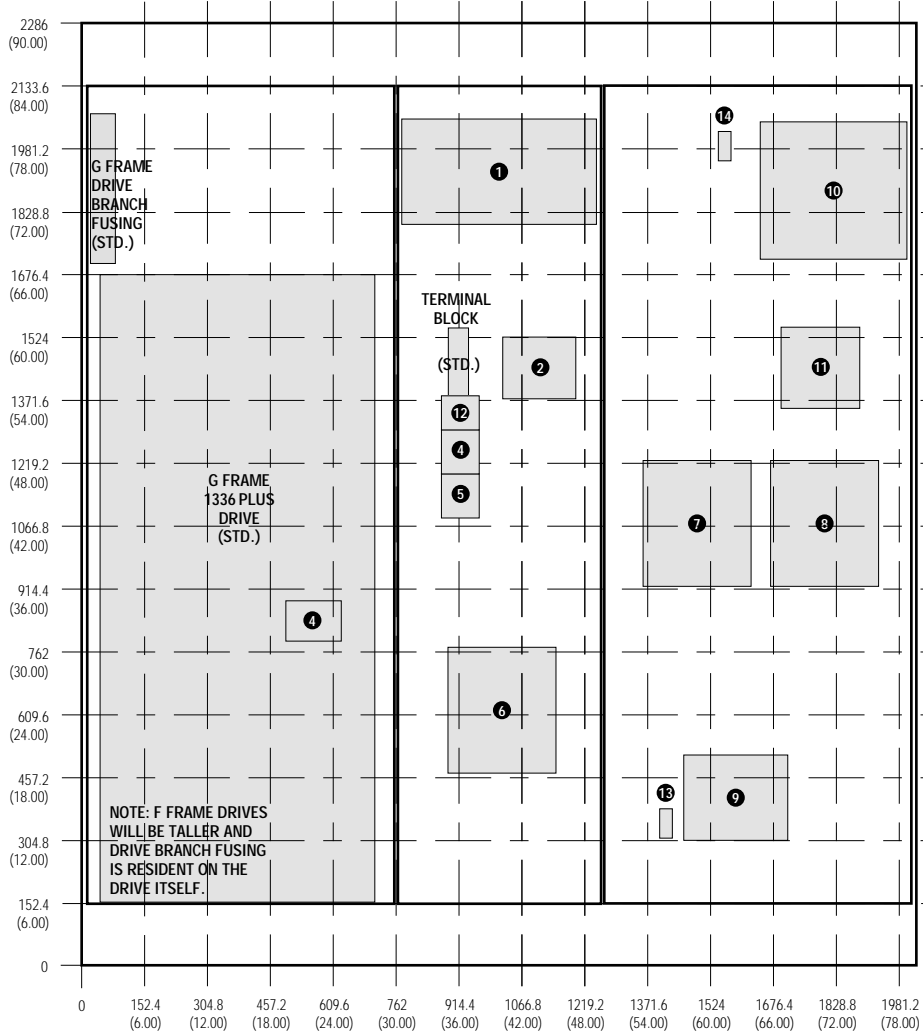

All Dimensions in Millimeters and (Inches)

- | | |
|--|---|
| ① DRIVE CIRCUIT BREAKER OR DISCONNECT SWITCH | ⑧ BYPASS CONTACTOR |
| ② CONTROL TRANSFORMER | ⑨ OVERLOAD RELAY |
| ③ RELAY LOGIC (VARIES) | ⑩ BYPASS CIRCUIT BREAKER OR DISCONNECT SWITCH |
| ④ COMMUNICATION OPTION CARD — DRIVE OR PANEL MOUNTED | ⑪ BYPASS MOTOR FUSES |
| ⑤ INPUT AND OUTPUT ISOLATORS | ⑫ BYPASS LOGIC |
| ⑥ DRIVE INPUT CONTACTOR | ⑬ MOTOR GROUND TERMINAL |
| ⑦ DRIVE OUTPUT CONTACTOR | ⑭ LINE GROUND TERMINAL |

¹ Not all ratings are available NEMA Type 12

Mounting Requirements

APPROVED MOUNTING METHODS

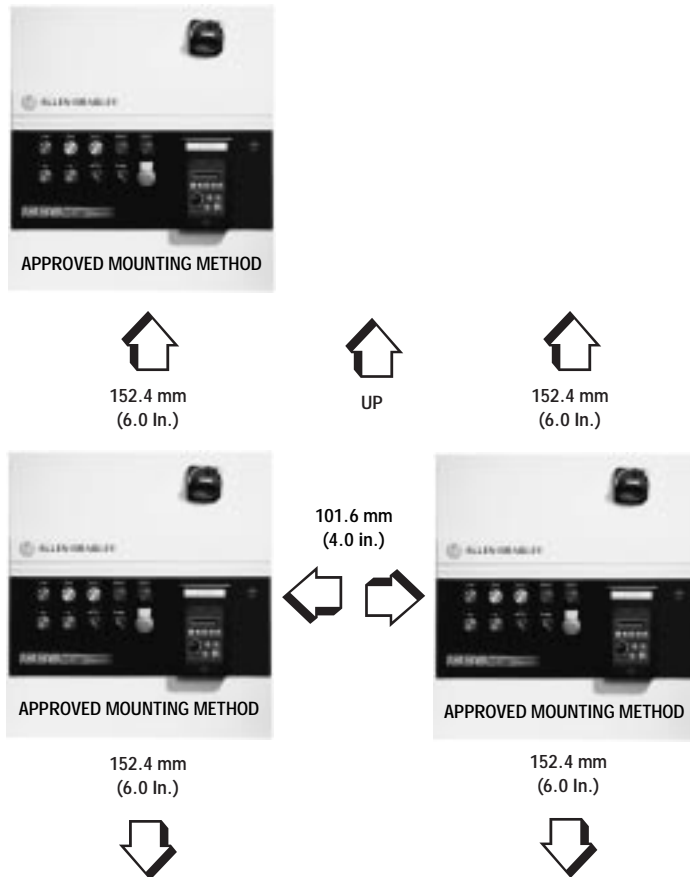

NOT ACCEPTABLE

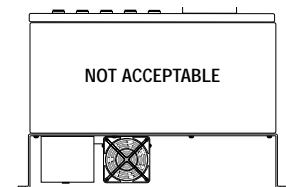
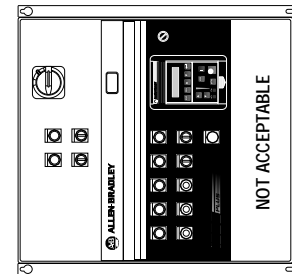

Input Conditioning

In general, the 1336 PLUS drive is suitable for direct connection to a correct voltage AC line that has a minimum impedance of 1% (3% for 0.37-22 kW/0.5-30 HP) drives relative to the rated drive input kVA. If the line has a lower impedance, a line reactor or isolation transformer must be added before the drive to increase line impedance. If the line impedance is too low, transient voltage spikes or interruptions can create excessive current spikes that will cause nuisance input fuse blowing and may cause damage to the drive power structure.

The basic rules for determining if a line reactor or isolation type transformer is required are as follows:

1. If the AC input power system does not have a neutral or one phase referenced to ground (Refer to **Ungrounded Distribution Systems**), an isolation transformer with the neutral of the secondary grounded is highly recommended. If the line-to-ground voltages on any phase can exceed 125% of the nominal line-to-line voltage, an isolation transformer with the neutral of the secondary grounded, is always required.
2. If the AC line supplying the drive has power factor correction capacitors that are switched in and out, an isolation transformer or 5% reactors are recommended between the drive and capacitors. If the capacitors are permanently connected and not switched, the general rules for impedance mismatch above apply.
3. If the AC line frequently experiences transient power interruptions or significant voltage spikes, an isolation transformer or 5% reactors are recommended.

AC Supply Source

1336 PLUS drives are suitable for use on a circuit capable of delivering up to a maximum of 200,000 rms symmetrical amperes, 600 volts maximum when used with drive branch fusing that is supplied as standard on all commercial drives.



ATTENTION: To guard against personal injury and/or equipment damage caused by improper fusing, use only the same drive branch fuses as originally supplied by the factory.

Unbalanced Distribution Systems

This drive is designed to operate on three-phase supply systems whose line voltages are symmetrical. Surge suppression devices are included to protect the drive from lightning induced overvoltages between line and ground. Where the potential exists for abnormally high phase-to-ground voltages (in excess of 125% of nominal), or where the supply ground is tied to another system or equipment that could cause the ground potential to vary with operation, suitable isolation is required for the drive. Where this potential exists, an isolation transformer is strongly recommended.

Ungrounded Distribution Systems

All 1336 PLUS drives are equipped with an MOV (Metal Oxide Varistor) that provides voltage surge protection and phase-to-phase and phase-to-ground protection which is designed to meet IEEE 587. The MOV circuit is designed for surge suppression only (transient line protection), not continuous operation.

With ungrounded distribution systems, the phase-to-ground MOV connection could become a continuous current path to ground. Energy ratings are listed below. Exceeding published line-to-line and line-to-ground voltage ratings may cause physical damage to the MOV.

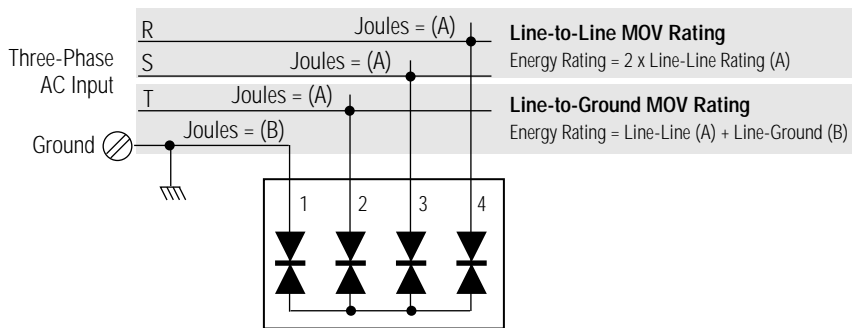

Frame Reference	A			B-C			D-G		
Device Rating (V)	240	480	600	240	480	600	240	480	600
Line-Line (A)	160	140	NA	160	160	160	140	140	150
Line-Ground (B)	220	220	NA	220	220	220	220	220	220

AC Supply Source (CONTINUED)

Drive Rating and Catalog Number

230V AC HP	230V AC Cat No.	460V AC-CT HP	460V AC-CT Cat No.	460V AC-VT HP	460V AC-VT Cat No.	575V AC HP	575V AC Cat No.	Fuse Description	Quantity Required	Vendor Part Number
—	—	0.5-0.75	BF05C, BF07C	0.5-0.75	BF05V, BF07V	—	—	3A	3	Bussmann LPJ-3
0.5-0.75	AF05C-AF07C	1-1.5	BF10C, BF15C	1-1.5	BF10V, BF15V	1	CF10C	6A	3	Bussmann LPJ-6
1	AF10C	2	BF20C	2	BF20V	2	CF20C	10A	3	Bussmann LPJ-10
1.5-2	AF15C-AF20C	3	BF30C	3	BF30V	3	CF30C	15A	3	Bussmann LPJ-15
—	—	5-7.5 (14A)	BF50C, BF75C	5, 10 (17.5A)	BF50V, BF75V	5	CF50C	20A	3	Bussmann LPJ-20
3	AF30C	—	—	—	—	—	—	25A	3	Bussmann LPJ-25
—	—	10 (17.5A)	BF100C	15 (25A)	BF100V	—	—	30A	3	Bussmann LPJ-30
—	—	—	—	—	—	7.5	C007C	15A	3	Bussmann JKS-15
—	—	7.5 (12.5A)	B007C	7.5-10 (14A)	BX007V, B007V	10	C010C	20A	3	Bussmann JKS-20
—	—	10 (16.1A)	B010C	—	—	15	C015C	25A	3	Bussmann JKS-25
—	—	—	—	15 (21A)	B010V	—	—	30A	3	Bussmann JKS-30
5	AF50C	—	—	—	—	—	—	40A	3	Bussmann LPJ-40
—	—	15	B015C	20	B015V	20	C020C	35A	3	Bussmann JKS-35
7.5	A007C	—	—	—	—	25	C025C	40A	3	Bussmann JKS-40
—	—	20	B020C	25	B020V	—	—	45A	3	Bussmann JKS-45
10	A010C	—	—	—	—	30	C030C	50A	3	Bussmann JKS-50
15	A015C	25-30	B025C, B030C	30	B030V	40	C040C	60A	3	Bussmann JKS-60
—	—	40	BX040C	40	BX040V	50	C050C	80A	3	Bussmann JKS-80
—	—	—	—	50	B040V	60	C060C	90A	3	Bussmann JKS-90
20-25	A020C-A025C	50-60	B050C, BX060C	60	BX060V	—	—	100A	3	Bussmann JKS-100
—	—	—	—	—	—	75	C075C	110A	3	Bussmann JKS-110
30	A030C	60	B060C	75	B060V	—	—	125A	3	Bussmann JKS-125
40	A040C	75	B075C	100	B075V	100	C100C	150A	3	Bussmann JKS-150
—	—	—	—	—	—	125	C125C	175A	3	Bussmann JKS-175
50	A050C	100	B100C	125	B100V	—	—	200A	3	Bussmann JKS-200
60	A060C	125	B125C	150	B125V	150	C150C	225A	3	Bussmann JKS-225
—	—	150	B150C, BX150C	—	—	—	—	250A	3	Bussmann JKS-250
75	A075C	—	—	200	B150V	—	—	300A	3	Bussmann JKS-300
—	—	200	B200C	—	—	200	C200C	350A	3	Bussmann JKS-350
100-125	A100C-A125C	250	B250C	250	B200V, B250V	250-300	C250C, CX300C	400A	3	Bussmann JKS-400
—	—	—	—	—	—	300	C300C	400A	3	Gould A2-70C400AT
—	—	300	B300C	300	BX250V	350	C350C	450A	3	Gould A3-70C450AT
—	—	250	BP250C	300	BP250V	—	—	450A	3	Gould A70QS-450
—	—	350	B350C	350	B300V	400	C400C	500A	3	Gould A3-70C500AT
—	—	300	BP300C	350	BP300V	—	—	500A	3	Gould A70QS-500
—	—	400	B400C	400	B350V	450	C450C	600A	3	Gould A3-70C600AT
—	—	350-400	BP350C, BP400C	400	BP350V	—	—	600A	3	Gould A70QS-600
—	—	450	BP450C	450	BP400V	—	—	700A	3	Gould A70QS-700
—	—	450-500	B450C, B500C	450-500	B400V, B450V	500-600	C500C, C600C	800A	3	Gould A3-70C800AT
—	—	600	B600C	600	B500V	—	—	900A	3	Gould A3-70C900AT

Power Wiring — Drive Terminal Block TB1

Input and output power connections are performed through a ten position terminal block, TB1. For maintenance and setup procedures, the drive may be operated without a motor connected. Configured 1336 PLUS drives provide input power short circuit fusing as standard.



ATTENTION: Any user supplied disconnecting means wired to drive output terminals U, V and W must be capable of disabling the drive if opened during drive operation. If opened during drive operation, the drive will continue to produce output voltage between U, V and W. An auxiliary contact must be used to simultaneously disable the drive or output component damage may occur.



ATTENTION: An incorrectly customer applied or installed bypass system can result in component damage or reduction in product life. The most common causes are:

- Wiring AC line to drive output or control terminals.
- Improper bypass or output circuits.
- Output circuits which do not connect directly to the motor.

Contact Allen-Bradley for assistance with application or wiring.

TB1 Specifications — Use 75°C Rated Wire

Ratings	Max./Min. Wire Size ¹ mm ² (AWG)	Maximum Torque N-m (in-lbs)
208/230V, 0.37-3.7 kW (0.5-5 HP) 460V, 0.37-11 kW (0.5-15 HP)	5.3/0.8 (10/18)	1.81 (16)
208/230V, 5.5 kW (7.5 HP) 460V, 5.5-11 kW (7.5-15 HP) 575V, 5.5-7.5 kW (7.5-10 HP)	8.4/0.8 (8/18)	1.81 (16)
208/230V, 7.5-11 kW (10-15 HP) 460V, 15-22 kW (20-30 HP) 575V, 11-15 kW (15-20 HP)	13.3/0.5 (6/20)	1.70 (15)
208/230V, 15-22 kW (20-30 HP) 460V, 30-45 kW (40-60 HP/77A) 575V, 18.5-45 kW (25-60 HP)	26.7/0.8 (3/18)	5.65 (50)
460V, 42-112 kW (60/85A-150 HP) ³ 575V, 56-112 kW (75-150 HP) ³	127.0/2.1 (250 MCM/14) 67.4/2.1 (00/14) ²	6.00 (52) 6.00 (52)
460V, 112-187 kW (150-250 HP) ³ 575V, 112-224 kW (150-300 HP) ³	253.0/2.1 (500 MCM/14)	10.00 (87)
460V, 112-187 kW (150-250 HP) ³ 575V, 187-448 kW (250-600 HP) ³	303.6/2.1 (600 MCM/14)	23.00 (200)

¹ Wire sizes given are maximum/minimum sizes that TB1 will accept — These are not recommendations.

² Applies to 30 kW (40 HP) 230V, 45 & 56 kW (60 & 75 HP) 460V, and 56 kW (75 HP) 575V drives only.

³ These configurations of TB1 are stud type terminations and require the use of lug type connectors to terminate the field installed conductors.

Power Wiring — Drive Terminal Block TB1 (CONTINUED)

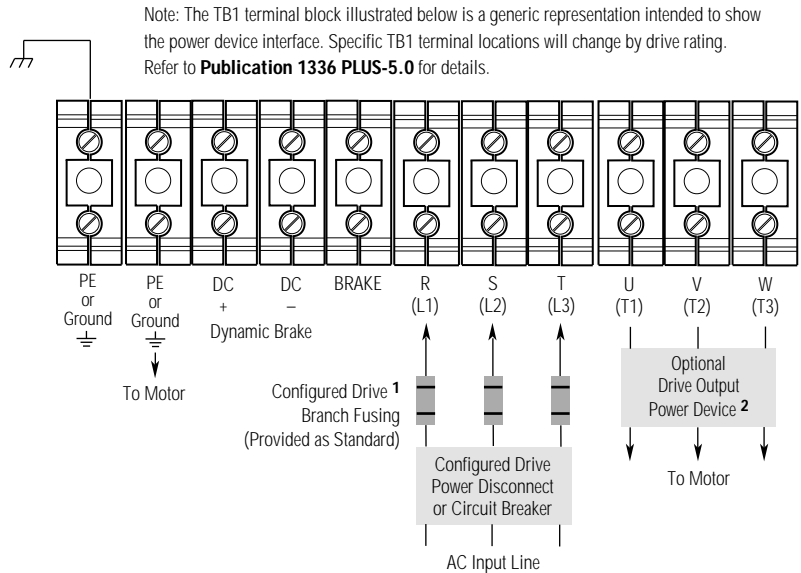

- ¹ Configured drives may have different input fuse ratings than those recommended for equivalent standard 1336 PLUS drives. Configured drives are rated for a single input voltage (not a voltage range) and may have fuses resident on an optional disconnect switch.
- ² If a drive output power option is not supplied, motor connections are made directly to terminals U, V and W.

TB1 Signals	
Terminal	Description
	Building Ground
TE	Shield Termination – True Earth
PE	Power Earth Ground
R (L1), S (L2), T (L3)	AC Line Input Terminals
+DC, –DC	DC Bus Terminals
U (T1), V (T2), W (T3)	Motor Connection

External Signal Wiring — TE

The TE Terminal block shown on the following page provides a terminating point for signal wiring shields.

The maximum and minimum wire size accepted by this block is 2.1 & 0.30 mm² (14 & 22 AWG). Maximum torque is 1.36 N-m (12 lb.-in.). Use Copper wire Only.

Control and Signal Wiring — Drive Terminal Block TB2

TB2 is located at the bottom of the Main Control Board. 0.37-7.5 kW (0.5-10 HP) drives have 18 positions. 5.5 kW (7.5 HP) and up have 22 positions. The maximum and minimum wire size accepted by TB2 is 2.1 and 0.30 mm² (14 and 22 AWG). Maximum torque for all terminals is 1.36 N-m (12 lb-in). Use copper wire only.

The recommended control signal wire is: Belden 8760 (or equivalent) — 0.750 mm² (18 AWG), twisted pair, shielded.
 Belden 8770 (or equivalent) — 0.750 mm² (18 AWG), 3 conductor, shielded.
 Belden 9460 (or equivalent) — 0.750 mm² (18 AWG), twisted pair, shielded.

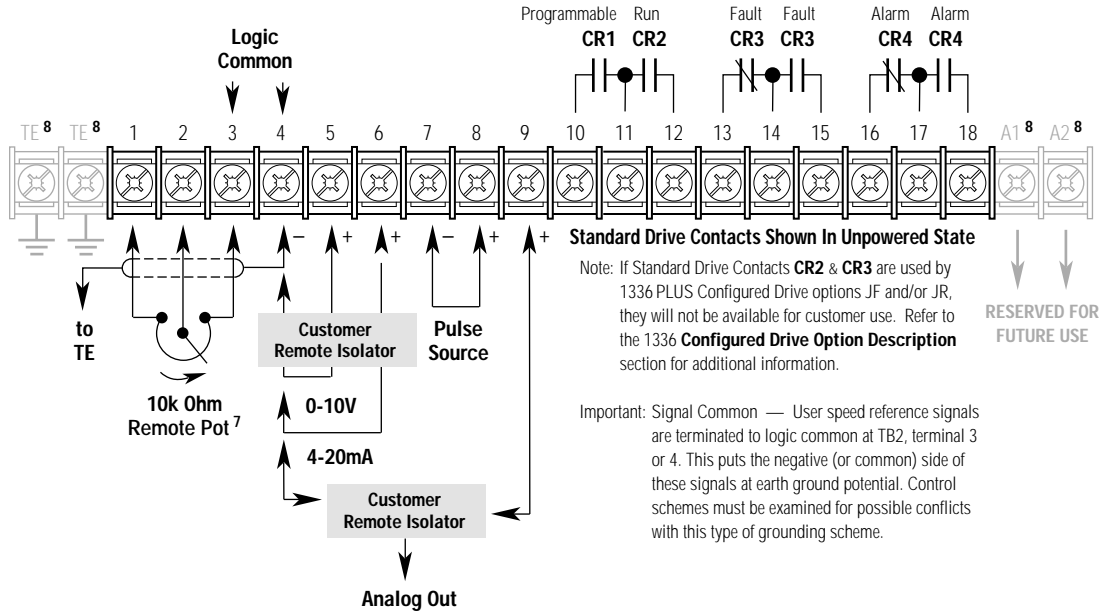

Terminal Block TB2 Specifications

Terminal Number(s)	Signal	
TE	True Earth – Logic/Shield Ground	
1, 2, 3	External Speed Pot or Analog Trim Pot ²	(10k Ohm Pot Required)
4	Signal Common	
5	0-10V DC Input: ²	Input Impedance = 100k Ohms
6	4-20 mA Input: ²	Input Impedance = 250 Ohms
7, 8	Pulse Input for Frequency Reference ⁴	Refer to Publication 1336 PLUS-5.0.
9	Analog Output: A Frame Drives ¹ B Frame Drives & Up ¹	Jumper JP1 to Select 0-10V DC Output ⁵ Jumper JP2 to Select 0-20 mA Output ⁶ Jumper J5 Selects Output: Pins 1-2 = 4-20 mA ⁶ Pins 3-4 = 0-10V DC ⁵
10, 11	CR1 Programmable Contact	Resistive Rating = 115V AC/30V DC, 5.0A Inductive Rating = 115V AC/30V DC, 2.0A
11, 12	CR2 Run Contact	Resistive Rating = 115V AC/30V DC, 5.0A Inductive Rating = 115V AC/30V DC, 2.0A
13, 14	CR3 Fault Contact	Resistive Rating = 115V AC/30V DC, 5.0A Inductive Rating = 115V AC/30V DC, 2.0A
14, 15	CR3 Fault NOT Contact	
16, 17	CR4 Alarm Contact	Resistive Rating = 115V AC/30V DC, 5.0A Inductive Rating = 115V AC/30V DC, 2.0A
17, 18	CR4 Alarm NOT Contact	
A1, A2	Reserved for Future Use	

¹ Refer to the I/O Config group parameters for analog scaling.

² Refer to (Maximum Speed) parameter.

³ Refer to Contact Description on following page.

⁴ Not available if Encoder Feedback option is used.

⁵ Minimum impedance to source: A Frame = 3.5k ohms, B Frame & Up = 1.5k ohms, Recommended load for All Frames = 10k ohms.

⁶ Maximum load: A Frame drives = 20mA into 260 ohms, B Frame drives & Up = 315 ohms

Control Interface Wiring — Drive Terminal Block TB3

Control interface inputs are connected to terminal Block TB3. TB3 is located on the Control Interface Board installed in the drive. All 1336 PLUS Configured Drives come with a 115V AC Control interface Card (Option L6)¹ unless otherwise specified. 24V AC/DC control and Contact Closure control are available as options. Encoder feedback is available as an option with any of the three control methods.

All control interface cards provide input terminals for access to fixed drive functions that include start, stop, remote auxiliary, speed, and enable. Four additional inputs are programmed for functions such as reverse, preset speed access, jog, second accel/decel time access and local control selection. The function of each input is defined through programming. For Configured Drives, functions are pre-programmed at the factory for a specific application and configuration and should not require field re-programming.

A variety of combinations made up of the following inputs are available.

Start	2 Accel/Decel Rates	2 Stop Mode Selects
Stop/Clear Fault	3 Speed Selects	Run Forward
Reverse	Enable	Run Reverse
Digital Potentiometer (MOP)	Auxiliary	Local Control



ATTENTION: The drive is intended to be controlled by control input signals that will start and stop the motor. A device that routinely disconnects then reapplies line power to the drive for the purpose of starting and stopping the motor **is not** recommended. If this type of circuit is used, a maximum of 3 stops in any 5 minute period with a minimum 1 minute rest between each cycle is required. These 5 minute periods must be separated by 10 minute rest cycles to allow the drive precharge resistors to cool. Refer to codes and standards applicable to your particular system for specific requirements and additional information.



ATTENTION: User remote speed reference signals are terminated to logic common at TB2 terminals 3 & 4. This puts the negative or common side of these signals at earth ground potential. Control schemes should be examined for possible conflict with this grounding scheme and possible equipment damage.

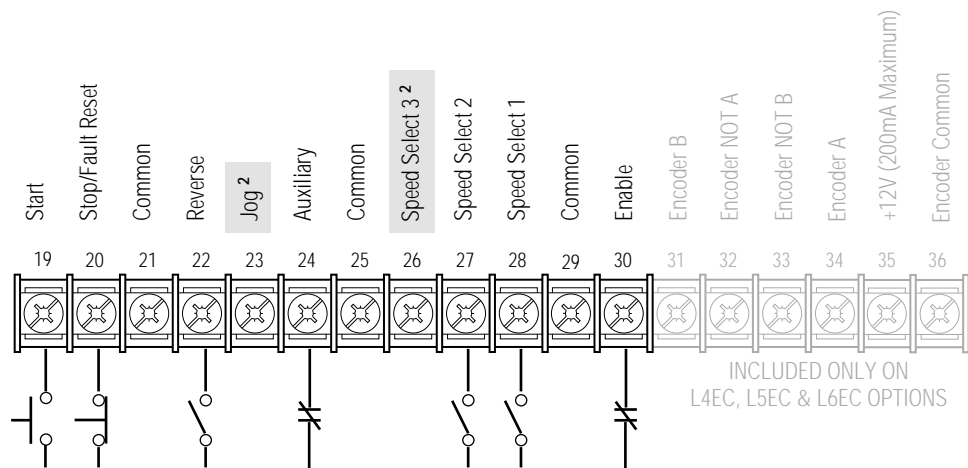

The maximum and minimum wire size accepted by TB3 is 2.1 and 0.30 mm² (14 and 22 AWG). Maximum torque for all terminals is 1.36 N-m (12 lb-in).

¹ Option L6 (115V AC Control Interface Board) is supplied as a default standard on all 1336 PLUS Configured Drives.

² Configured drives will generally be factory programmed for the control scheme shown (Parameter 21 set to 2). Refer to publication 1336 PLUS-5.0 for further information.

Motor Power Wiring

A variety of cable types are acceptable for drive installations. For many installations, unshielded cable is adequate, provided it can be separated from sensitive circuits. As an approximate guide, allow a spacing of 0.3 meters (1 foot) for every 10 meters (32.8 feet) of length. In all cases, long parallel runs must be avoided. Do not use cable with an insulation thickness less than or equal to 15 mils.

The cable should be 4-conductor with the ground lead being connected directly to the drive ground terminal (PE) and the motor frame ground terminal.

Shielded Cable

Shielded cable is recommended if sensitive circuits or devices are connected or mounted to the machinery driven by the motor. The shield must be connected to both the drive ground (drive end) and motor frame ground (motor end). The connection must be made at both ends to minimize interference.

If cable trays or large conduits are to be used to distribute the motor leads for multiple drives, shielded cable is recommended to reduce or capture the noise from the motor leads and minimize “cross coupling” of noise between the leads of different drives. The shield should be connected to the ground connections at both the motor and drive end.

Armored cable also provides effective shielding. Ideally it should be grounded only at the drive (PE) and motor frame. Some armored cable has a PVC coating over the armor to prevent incidental contact with grounded structure. If, due to the type of connector, the armor is grounded at the cabinet entrance, shielded cable should be used within the cabinet if power leads will be run close to control signals.

In some hazardous environments it is not permissible to ground both ends of the cable armor because of the possibility of high current circulating at the input frequency if the ground loop is cut by a strong magnetic field. This only applies in the proximity of powerful electrical machines. In such cases, consult factory for specific guidelines.

Conduit

If metal conduit is preferred for cable distribution, the following guidelines must be followed.

- Drives are normally mounted in cabinets and ground connections are made at a common ground point in the cabinet. Normal installation of conduit provides grounded connections to both the motor frame ground (junction box) and drive cabinet ground. These ground connections help minimize interference. This is a noise reduction recommendation only, and does not affect the requirements for safety grounding.
- No more than three sets of motor leads can be routed through a single conduit. This will minimize “cross talk” that could reduce the effectiveness of the noise reduction methods described. If more than three drive/motor connections per conduit are required, shielded cable as previously described must be used. If practical, each conduit should contain only one set of motor leads.



ATTENTION: To avoid a possible shock hazard caused by induced voltages, unused wires in the conduit must be grounded at both ends. For the same reason, if a drive sharing a conduit is being serviced or installed, all drives using this conduit should be disabled. This will eliminate the possible shock hazard from “cross coupled” drive motor leads.

Common Mode Cores

Optional Common Mode Cores will reduce the common mode noise at the drive output and guard against interference with other electrical equipment (programmable controllers, sensors, analog circuits, etc.). In addition, reducing the PWM carrier frequency will reduce the effects and lower the risk of common mode noise interference.

Motor Power Wiring (continued)

Motor Lead Length

Installations with long cables to the motor may require the addition of output reactors or cable terminators to limit voltage reflections at the motor. Refer to the table below for the maximum cable length allowed with various installation techniques. For installations that exceed the recommended maximum lengths listed, contact the factory.

Recommended Motor Cable Lengths for 460V Drives ³

Maximum Motor Cable Length Restrictions - 380V-480V Drives ¹																						
		No External Devices				w/1204-TFB2 Term.			w/1204-TFA1 Terminator				Reactor at Drive ²									
		Motor				Motor			Motor				Motor									
Drive Frame	Drive kW (HP)	Motor kW (HP)	A	B	1329	1329R/L	A or B		1329	A		B		1329	A	B or 1329						
			Any Cable	Any Cable	Any Cable	Any Cable	Cable Type Shld. ³	Unshld.	Any Cable	Cable Type Shld. ³	Unshld.	Cable Type Shld. ³	Unshld.	Any Cable	Any Cable	Any Cable						
A1	0.37 (0.5)	0.37 (0.5)	12.2 (40)	33.5 (110)	91.4 (300)	91.4 (300)	Use 1204-TFA1			30.5 (100)	61.0 (200)	30.5 (100)	61.0 (200)	91.4 (300)	22.9 (75)	182.9 (600)						
	0.75 (1)	0.75 (1)	12.2 (40)	33.5 (110)	91.4 (300)	91.4 (300)				30.5 (100)	30.5 (100)	30.5 (100)	30.5 (100)	91.4 (300)	22.9 (75)	182.9 (600)						
		0.37 (0.5)	12.2 (40)	33.5 (110)	91.4 (300)	91.4 (300)				30.5 (100)	61.0 (200)	30.5 (100)	61.0 (200)	91.4 (300)	22.9 (75)	182.9 (600)						
A2	1.2 (1.5)	1.2 (1.5)	12.2 (40)	33.5 (110)	91.4 (300)	91.4 (300)				Use 1204-TFA1			30.5 (100)	30.5 (100)	61.0 (200)	61.0 (200)	91.4 (300)	22.9 (75)	182.9 (600)			
	0.75 (1)	0.75 (1)	12.2 (40)	33.5 (110)	91.4 (300)	91.4 (300)							30.5 (100)	30.5 (100)	61.0 (200)	61.0 (200)	91.4 (300)	22.9 (75)	182.9 (600)			
	0.37 (0.5)	12.2 (40)	33.5 (110)	114.3 (375)	121.9 (400)	121.9 (400)							30.5 (100)	30.5 (100)	61.0 (200)	61.0 (200)	121.9 (400)	22.9 (75)	182.9 (600)			
1.5 (2)	1.5 (2)	7.6 (25)	12.2 (40)	91.4 (300)	91.4 (300)	91.4 (300)							Use 1204-TFA1			30.5 (100)	30.5 (100)	91.4 (300)	61.0 (200)	91.4 (300)	22.9 (75)	182.9 (600)
	1.2 (1.5)	7.6 (25)	12.2 (40)	114.3 (375)	182.9 (600)	182.9 (600)										30.5 (100)	30.5 (100)	91.4 (300)	61.0 (200)	182.9 (600)	22.9 (75)	182.9 (600)
	0.75 (1)	7.6 (25)	12.2 (40)	114.3 (375)	182.9 (600)	182.9 (600)										30.5 (100)	30.5 (100)	91.4 (300)	61.0 (200)	182.9 (600)	22.9 (75)	182.9 (600)
	0.37 (0.5)	7.6 (25)	12.2 (40)	114.3 (375)	182.9 (600)	182.9 (600)	30.5 (100)	30.5 (100)	91.4 (300)							61.0 (200)	182.9 (600)	22.9 (75)	182.9 (600)			
2.2 (3)	2.2 (3)	7.6 (25)	12.2 (40)	91.4 (300)	91.4 (300)	91.4 (300)	Use 1204-TFA1									30.5 (100)	30.5 (100)	91.4 (300)	61.0 (200)	91.4 (300)	22.9 (75)	182.9 (600)
	1.5 (2)	7.6 (25)	12.2 (40)	114.3 (375)	182.9 (600)	182.9 (600)										30.5 (100)	30.5 (100)	91.4 (300)	61.0 (200)	182.9 (600)	22.9 (75)	182.9 (600)
	0.75 (1)	7.6 (25)	12.2 (40)	114.3 (375)	182.9 (600)	182.9 (600)				30.5 (100)	30.5 (100)	91.4 (300)				61.0 (200)	182.9 (600)	22.9 (75)	182.9 (600)			
	0.37 (0.5)	7.6 (25)	12.2 (40)	114.3 (375)	182.9 (600)	182.9 (600)				30.5 (100)	30.5 (100)	91.4 (300)				61.0 (200)	182.9 (600)	22.9 (75)	182.9 (600)			
A3	3.7 (5)	3.7 (5)	7.6 (25)	12.2 (40)	114.3 (375)	114.3 (375)				Note For applications/installations using new motors, no restrictions in lead length due to voltage reflection are necessary. You should observe standard practices for voltage drop, cable capacitance, and other issues. For retrofit situations, check with the motor manufacturer for insulation rating.						182.9 (600)	182.9 (600)	182.9 (600)	182.9 (600)	182.9 (600)	22.9 (75)	182.9 (600)
	2.2 (3)	7.6 (25)	12.2 (40)	114.3 (375)	114.3 (375)	182.9 (600)							182.9 (600)	182.9 (600)	182.9 (600)	182.9 (600)	22.9 (75)	182.9 (600)				
	1.5 (2)	7.6 (25)	12.2 (40)	114.3 (375)	114.3 (375)	182.9 (600)							182.9 (600)	182.9 (600)	182.9 (600)	182.9 (600)	22.9 (75)	182.9 (600)				
	0.75 (1)	7.6 (25)	12.2 (40)	114.3 (375)	114.3 (375)	182.9 (600)							182.9 (600)	182.9 (600)	182.9 (600)	182.9 (600)	22.9 (75)	182.9 (600)				
	0.37 (0.5)	7.6 (25)	12.2 (40)	114.3 (375)	114.3 (375)	182.9 (600)							182.9 (600)	182.9 (600)	182.9 (600)	182.9 (600)	22.9 (75)	182.9 (600)				
A4	5.5-7.5 (7.5-10)	5.5-7.5 (7.5-10)	7.6 (25)	12.2 (40)	114.3 (375)	114.3 (375)	182.9 (600)	182.9 (600)	182.9 (600)				182.9 (600)	182.9 (600)	182.9 (600)	22.9 (75)	182.9 (600)					
B	5.5-22 (7.5-30)	5.5-22 (7.5-30)	7.6 (25)	12.2 (40)	114.3 (375)	114.3 (375)	182.9 (600)	182.9 (600)	182.9 (600)				182.9 (600)	182.9 (600)	182.9 (600)	24.4 (80)	182.9 (600)					
C	30-45 (X40-X60)	30-45 (40-60)	7.6 (25)	12.2 (40)	114.3 (375)	114.3 (375)	182.9 (600)	182.9 (600)	182.9 (600)				182.9 (600)	182.9 (600)	182.9 (600)	76.2 (250)	182.9 (600)					
D	45-112 (60-X150)	45-112 (60-150)	12.2 (40)	30.5 (100)	114.3 (375)	114.3 (375)	182.9 (600)	182.9 (600)	182.9 (600)				182.9 (600)	182.9 (600)	182.9 (600)	61.0 (200)	91.4 (300)					
E	112-187 (150-250)	112-224 (150-300)	12.2 (40)	53.3 (175)	114.3 (375)	114.3 (375)	182.9 (600)	182.9 (600)	182.9 (600)	182.9 (600)	182.9 (600)	182.9 (600)	182.9 (600)	182.9 (600)								
F	187-336 (250-450)	187-336 (250-450)	18.3 (60)	53.3 (175)	114.3 (375)	114.3 (375)	182.9 (600)	182.9 (600)	182.9 (600)	182.9 (600)	182.9 (600)	182.9 (600)	182.9 (600)	182.9 (600)								
G	187-448 (X250-600)	187-448 (250-600)	18.3 (60)	53.3 (175)	114.3 (375)	114.3 (375)	182.9 (600)	182.9 (600)	182.9 (600)	182.9 (600)	182.9 (600)	182.9 (600)	182.9 (600)	182.9 (600)								

Type A Motor Characteristics: No phase paper or misplaced phase paper, lower quality insulation systems, corona inception voltages between 850 and 1000 volts.

Type B Motor Characteristics: Properly placed phase paper, medium quality insulation systems, corona inception voltages between 1000 and 1200 volts.

1329R Motors: These AC Variable Speed motors are "Power Matched" for use with Allen-Bradley Drives. Each motor is energy efficient and designed to meet or exceed the requirements of the Federal Energy Act of 1992. All 1329R motors are optimized for variable speed operation and include premium inverter grade insulation systems which meet or exceed NEMA MG1, Part 31.40.4.2.

Refer to page 68 for footnotes.

Motor Power Wiring (continued)

Maximum Motor Cable Length Restrictions - 500V-600V Drives ⁴																		
		No External Devices				w/1204-TFB2 Terminator			w/1204-TFA1 Terminator			Reactor at Drive ²						
		Motor				Motor			Motor			Motor						
		A	B	1600V or 1329R/L ⁶		A	B	1600V or 1329R/L ⁶		A	B	1600V or 1329R/L ⁶						
Drive Frame	Drive kW (HP)	Motor kW (HP)	Any Cable	Any Cable	Any Cable	Any Cable	Any Cable	Any Cable	Any Cable	Any Cable	Any Cable	Any Cable	Any Cable	Any Cable				
A4	0.75 (1)	0.75 (1)	NR	NR	15.2 (50)	NR	182.9 (600)	335.3 (1100)	NR	61.0 (200)	182.9 (600)	Not Recommended						
		0.37 (0.5)	NR	NR	15.2 (50)	NR	182.9 (600)	335.3 (1100)	NR	61.0 (200)	182.9 (600)							
	1.5 (2)	1.5 (2)	NR	NR	15.2 (50)	NR	182.9 (600)	335.3 (1100)	NR	61.0 (200)	182.9 (600)							
		1.2 (1.5)	NR	NR	15.2 (50)	NR	182.9 (600)	335.3 (1100)	NR	61.0 (200)	182.9 (600)							
	2.2 (3)	0.75 (1)	NR	NR	15.2 (50)	NR	182.9 (600)	335.3 (1100)	NR	61.0 (200)	182.9 (600)							
		0.37 (0.5)	NR	NR	15.2 (50)	NR	182.9 (600)	335.3 (1100)	NR	61.0 (200)	182.9 (600)							
		2.2 (3)	NR	NR	15.2 (50)	NR	182.9 (600)	335.3 (1100)	NR	61.0 (200)	182.9 (600)							
		1.5 (2)	NR	NR	15.2 (50)	NR	182.9 (600)	335.3 (1100)	NR	61.0 (200)	182.9 (600)							
	3.7 (5)	0.75 (1)	NR	NR	15.2 (50)	NR	182.9 (600)	335.3 (1100)	NR	61.0 (200)	182.9 (600)							
		0.37 (0.5)	NR	NR	15.2 (50)	NR	182.9 (600)	335.3 (1100)	NR	61.0 (200)	182.9 (600)							
		3.7 (5)	NR	NR	15.2 (50)	NR	182.9 (600)	335.3 (1100)	NR	61.0 (200)	182.9 (600)							
		2.2 (3)	NR	NR	15.2 (50)	NR	182.9 (600)	335.3 (1100)	NR	61.0 (200)	182.9 (600)							
		1.5 (2)	NR	NR	15.2 (50)	NR	182.9 (600)	335.3 (1100)	NR	61.0 (200)	182.9 (600)							
	B	5.5-15 (7.5-20)	5.5-15 (7.5-20)	NR	9.1 (30)	15.2 (50)	91.4 (300)	182.9 (600)	182.9 (600)	NR	61.0 (200)				182.9 (600)	30.5 (100)	91.4 (300)	182.9 (600)
		C	18.5-45 (25-60)	18.5-45 (25-60)	NR	9.1 (30)	12.2 (40)	91.4 (300)	182.9 (600)	182.9 (600)	NR				61.0 (200)	182.9 (600)	30.5 (100)	91.4 (300)
	D		56-93 (75-125)	56-93 (75-125)	NR	9.1 (30)	33.5 (110)	91.4 (300)	182.9 (600)	182.9 (600)	NR				61.0 (200)	182.9 (600)	61.0 (200)	91.4 (300)
E		112-224 (150-X300)	112-224 (150-X300)	NR	9.1 (30)	21.3 (70)	91.4 (300)	182.9 (600)	182.9 (600)	NR	61.0 (200)	182.9 (600)	182.9 (600)	182.9 (600)	182.9 (600)			
	F	187-336 (250-450)	187-336 (250-450)	NR	9.1 (30)	41.1 (135)	91.4 (300)	182.9 (600)	182.9 (600)	NR	61.0 (200)	182.9 (600)	182.9 (600)	182.9 (600)	182.9 (600)			
G		224-448 (300-600)	224-448 (300-600)	NR	9.1 (30)	41.1 (135)	91.4 (300)	182.9 (600)	182.9 (600)	NR	61.0 (200)	182.9 (600)	182.9 (600)	182.9 (600)	182.9 (600)			

NR = Not Recommended

- ¹ Values shown are for 480V nominal input voltage and drive carrier frequency of 2 kHz. Consult factory regarding operation at carrier frequencies above 2 kHz. Multiply values by 0.85 for high line conditions. For input voltages of 380, 400 or 415VAC, multiply the table values by 1.25, 1.20 or 1.15, respectively.
- ² A 3% reactor reduces motor and cable stress but may cause a degradation of motor waveform quality. Reactors must have a turn-turn insulation rating of 2100 volts or higher.
- ³ Includes wire in conduit.
- ⁴ Values shown are for nominal input voltage and drive carrier frequency of 2 kHz. Consult factory regarding operation at carrier frequencies above 2 kHz. Multiply values by 0.85 for high line conditions.
- ⁵ Information not available at time of printing.
- ⁶ 1329R and 1329L motors at 600V are rated at approximately 1850V insulation value.
- ⁷ These distance restrictions are due to charging of cable capacitance and may vary from application to application.

Cable Termination

Optional Cable Terminator

Voltage doubling at motor terminals, known as reflected wave phenomenon, standing wave or transmission line effect, can occur when using drives with long motor cables.

Inverter duty motors with phase-to-phase insulation ratings of 1200 volts or higher should be used to minimize effects of reflected wave on motor insulation life.

Applications with non-inverter duty motors or any motor with exceptionally long leads may require an output filter or cable terminator. A filter or terminator will help limit reflection to the motor, to levels which are less than the motor insulation rating.

The tables on pages 67 and 68 list the maximum recommended cable length for unterminated cables, since the voltage doubling phenomenon occurs at different lengths for different drive ratings. If your installation requires longer motor cable lengths, a reactor or cable terminator is recommended. Also, refer to these tables for frequency, cable length and voltage restrictions of 1204-TFA1 or 1204-TFB2 terminators.

Installation Cooling Requirements and Derating Guidelines

Use the following information and curves to determine possible derating requirements for your application.

230V Drives ¹			460V Drives ¹				575V Drives ¹		
Cat No.	Base Derate Amps ¹	Derate Curve ^{2, 3, 4}	Constant Torque Cat No.	Variable Torque Cat No.	Base Derate Amps ¹	Derate Curve ^{2, 3, 4}	Cat No.	Base Derate Amps ¹	Derate Curve ^{2, 3, 4}
AF05C	2.3	Figure 1	BF05C	BF05V	1.2	Figure 1	CF10C	2	NONE
AF07C	3	Figure 1	BF07C	BF07V	1.7	Figure 1	CF20C	4	NONE
AF10C	4.5	Figure 1	BF10C	BF10V	2.3	Figure 1	CF30C	6	NONE
AF15C	6	Figure 1	BF15C	BF15V	3	Figure 1	CF50C	8	NONE
AF20C	8	Figure 1	BF20C	BF20V	4	Figure 1	C007C	10	NONE
AF30C	12	Figure 1	BF30C	BF30V	6	Figure 1	C010C	12	NONE
AF50C	18	Figure 1	BF50C	BF50V	9	Figure 1	C015C	19	NONE
A007C	27	NONE	BF75C	BF75V	17.5	Figure 1	C020C	24	NONE
A010C	34	Figure 2	—	BX007V	14	Figure 1	C025C	30	NONE
A015C	48	Figure 4	B007C	B007V	14	NONE	C030C	35	NONE
A020C	65	NONE	B010C	B010V	21	NONE	C040C	45	NONE
A025C	77	NONE	BF100C	BF100V	25	Figure 1	C050C	57	NONE
A030C	80	NONE	B015C	B015V	27	NONE	C060C	62	⁵
A040C	120	Figure 7	B020C	B020V	34	Figure 2	C075C	85	Figure 7
A050C	150	Figure 8	B025C	—	42	Figure 3	C100C	109	Figure 9
A060C	180	Figure 10	B030C	B030V	48	Figure 4	C125C	138	Figure 11
A075C	240	Figure 12	BX040C	BX040V	59	Figure 5	C150C	168	Figure 16
A100C	291	Figure 13	—	B040V	65	Figure 5	C200C	252	Figure 17
A125C	325	Figure 14	B050C	—	77	Figure 6	C250C	325	Figure 18
			BX060C	BX060V	77	Figure 6	C300C	300	Figure 19/20
			B060C	B060V	96	NONE	CX300C	300	Figure 21
			B075C	B075V	120	Figure 7	C350C	350	Figure 19/20
			B100C	B100V	150	Figure 8	C400C	400	Figure 19/20
			B125C	B125V	180	Figure 10	C450C	450	Figure 19/20
			BX150C	—	180	Figure 10	C500C	500	Figure 19/20
			B150C	B150V	240	Figure 12	C600C	600	Figure 19/20
			B200C	B200V	292	Figure 13			
			B250C	B250V	325	Figure 14			
			—	BX250V	360	NONE			
			BP250C	BP250V	322	Figure 5			
			B300C	B300V	425	NONE			
			BP300C	BP300V	357	Figure 5			
			B350C	B350V	475	NONE			
			BP350C	BP350V	421	Figure 5			
			B400C	B400V	525	NONE			
			BP400C	BP400V	471	Figure 5			
			B450C	B450V	590	NONE			
			BP450C	—	527	Figure 5			
			B500C	B500V	670	Figure 15			
			B600C	—	670	Figure 15			

¹ Base Derate Amps are based on nominal voltage (240, 480 or 600V). If input voltage exceeds drive rating, drive output must be derated. Refer to **Figure 22**.

² Amp rating is at 4 kHz. If carrier frequencies above 4 kHz are selected, drive Amp Rating must be derated. Refer to **Figures 1-20**.

³ Drive ambient temperature rating is 40°C. If ambient exceeds 40°C, the drive must be derated. Refer to **Figures 1-20**.

⁴ Drive rating is based on altitudes of 1,000 m (3,000 ft) or less. If installed at higher altitude, drive must be derated. Refer to **Figure 21**.

⁵ Not available at time of publication.

Derating Guidelines

Drive ratings can be affected by a number of factors. If more than one factor exists, derating percentages must be multiplied. For example, if a 14 Amp drive (B007) is installed at a 2,000 m (6,600 ft.) altitude **and** has a 2% high input line voltage, the actual amp rating will be:

$$14 \times 94\% \text{ Altitude Derate} \times 96\% \text{ High Line Derate} = 12.6 \text{ Amps}$$

Ambient Temperature/Carrier Frequency

Figure 1

AF05C-AF50C — 0.37-3.7 kW (0.5-5 HP), 230V AC (CT)
 BF05C-BF100C — 0.37-7.5 kW (0.5-10 HP), 460V AC (CT)
 BF05V-BF100V — 0.37-7.5 kW (0.5-10 HP), 460V AC (VT)
 BX007V — 5.5 kW (7.5 HP), 460V AC (VT)

— Standard Rating for Enclosed Drive in 40°C Ambient.

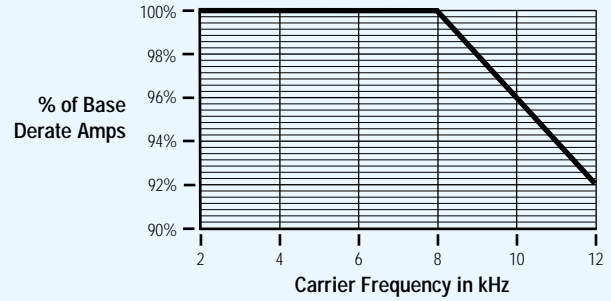

Figure 2

A010C — 7.5 kW (10 HP), 230V AC (CT)
 B020C — 7.5 kW (20 HP), 460V AC (CT)
 B020V — 18.5 kW (25 HP), 460V AC (VT)

— Standard Rating for Enclosed Drive in 40°C Ambient.
 — Derating Factor for Enclosed Drive in 41-50°C Ambient.

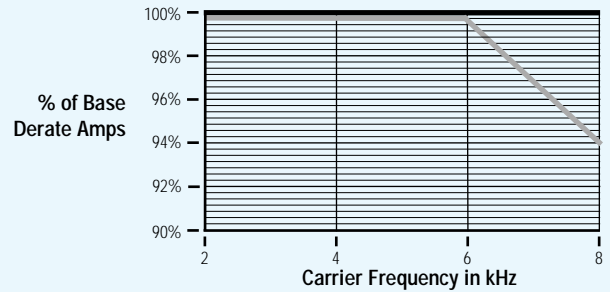

Figure 3

B025C — 15 kW (25 HP), 460V AC (CT)

— Standard Rating for Enclosed Drive in 40°C Ambient.
 — Derating Factor for Enclosed Drive in 41-50°C Ambient.

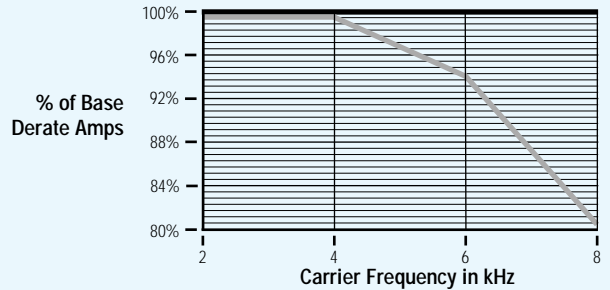
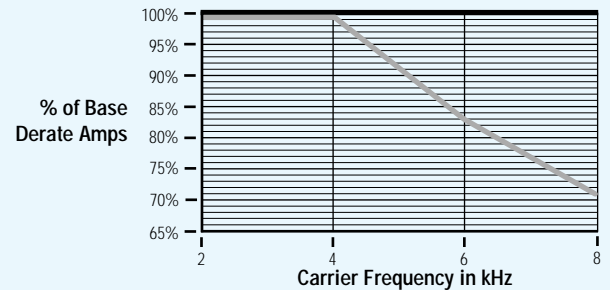

Figure 4

A015C — 11 kW (15 HP), 230V AC (CT)
 B030C — 22 kW (30 HP), 460V AC (CT)
 B030V — 22 kW (30 HP), 460V AC (VT)

— Standard Rating for Enclosed Drive in 40°C Ambient.
 — Derating Factor for Enclosed Drive in 41-50°C Ambient.



Ambient Temperature/Carrier Frequency (CONTINUED)

Figure 5

BX040C — 30 kW (40 HP), 460V AC (CT)
 BX040V-B040V — 30-37 kW (40-50 HP), 460V AC (VT)

— Standard Rating for Enclosed Drive in 40°C Ambient.
 — Derating Factor for Enclosed Drive in 41-50°C Ambient.

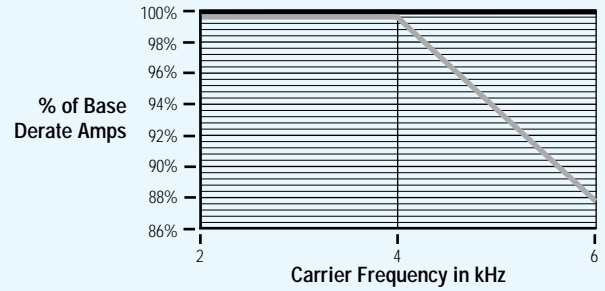

Figure 6

B050C-BX060C — 37-45 kW (50-60 HP), 460V AC (CT)
 BX060V — 45 kW (60 HP), 460V AC (VT)

— Standard Rating for Enclosed Drive in 40°C Ambient.
 — Derating Factor for Enclosed Drive in 41-50°C Ambient.

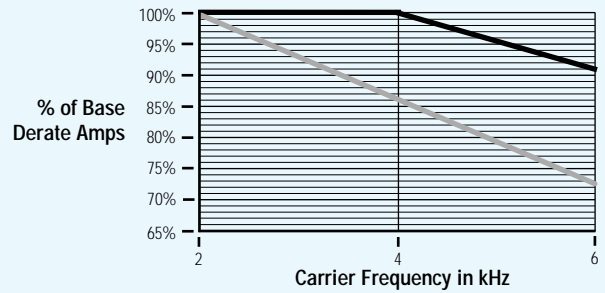

Figure 7

A040C — 30 kW (40 HP), 230V AC (CT)
 B075C — 56 kW (75 HP), 460V AC (CT)
 B075V — 75 kW (100 HP), 460V AC (VT)
 C075C — 56 kW (75 HP), 575V AC (CT)

— Standard Rating for Enclosed Drive in 40°C Ambient.
 — Derating Factor for Enclosed Drive in 41-50°C Ambient.

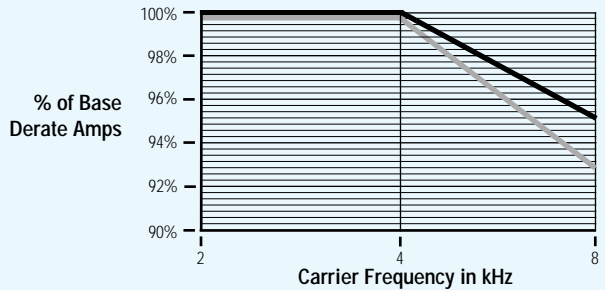
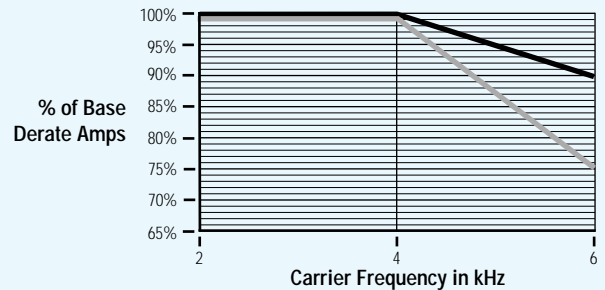

Figure 8

A050C — 37 kW (50 HP), 230V AC (CT)
 B100C — 75 kW (100 HP), 460V AC (CT)
 B100V — 93 kW (125 HP), 460V AC (VT)

— Standard Rating for Enclosed Drive in 40°C Ambient.
 — Derating Factor for Enclosed Drive in 41-50°C Ambient.



Ambient Temperature/Carrier Frequency (CONTINUED)

Figure 9

C100C — 75 kW (100 HP), 575V AC (CT)

- Standard Rating for Enclosed Drive in 40°C Ambient.
- Derating Factor for Enclosed Drive in 41-50°C Ambient.

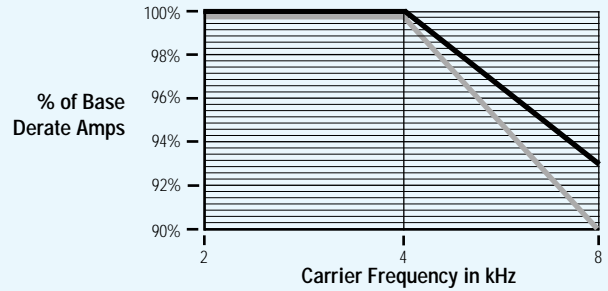

Figure 10

A060C — 45 kW (60 HP), 230V AC (CT)
 B125C-BX150C — 93-112 kW (125-150 HP), 460V AC (CT)
 B125V — 112 kW (150 HP), 460V AC (VT)

- Standard Rating for Enclosed Drive in 40°C Ambient.
- Derating Factor for Enclosed Drive in 41-50°C Ambient.

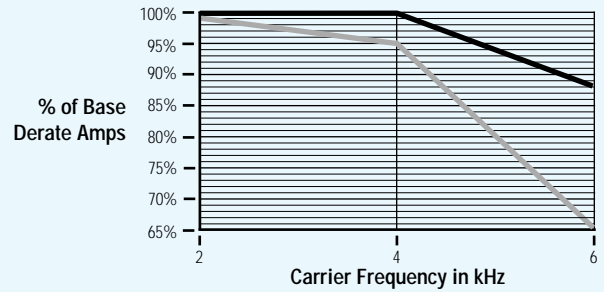

Figure 11

C125C — 93 kW (125 HP), 575V AC (CT)

- Standard Rating for Enclosed Drive in 40°C Ambient.
- Derating Factor for Enclosed Drive in 41-50°C Ambient.

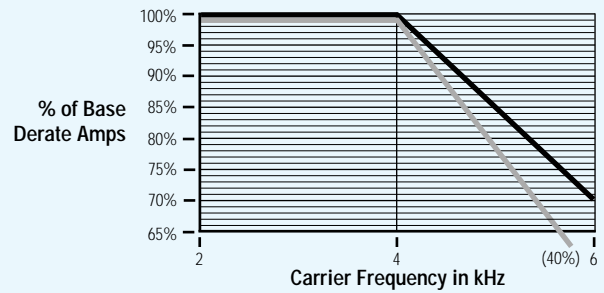
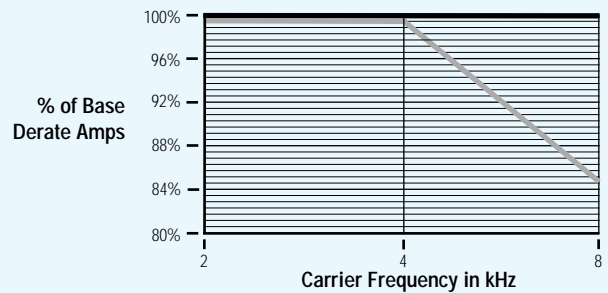

Figure 12

A075C — 56 kW (75 HP), 230V AC (CT)
 B150C — 112 kW (150 HP), 460V AC (CT)
 B150V — 149 kW (200 HP), 460V AC (VT)

- Standard Rating for Enclosed Drive in 40°C Ambient.
- Derating Factor for Enclosed Drive in 41-50°C Ambient.



Ambient Temperature/Carrier Frequency (CONTINUED)

Figure 13

A100C — 37 kW (100 HP), 230V AC (CT)
 B200C — 149 kW (200 HP), 460V AC (CT)
 B200V — 187 kW (250 HP), 460V AC (VT)

— Standard Rating for Enclosed Drive in 40°C Ambient.
 — Derating Factor for Enclosed Drive in 41-50°C Ambient.

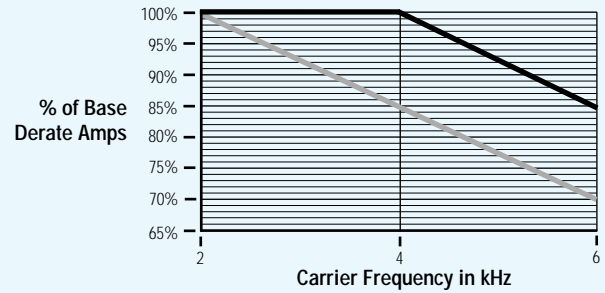

Figure 14

A125C — 93 kW (125 HP), 230V AC (CT)
 B250C — 187 kW (250 HP), 460V AC (CT)
 B250V — 187 kW (250 HP), 460V AC (VT)

— Standard Rating for Enclosed Drive in 40°C Ambient.
 — Derating Factor for Enclosed Drive in 41-50°C Ambient.

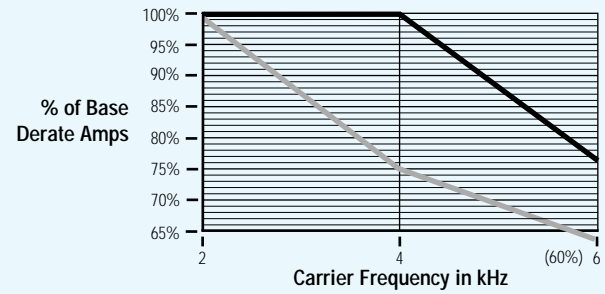

Figure 15

B500C-B600C — 373-448 kW (500-600 HP), 460V AC (CT)
 B500V — 448 kW (600 HP), 460V AC (VT)

— Standard Rating for Enclosed Drive in 40°C Ambient.
 — Derating Factor for Enclosed Drive in 41-50°C Ambient.

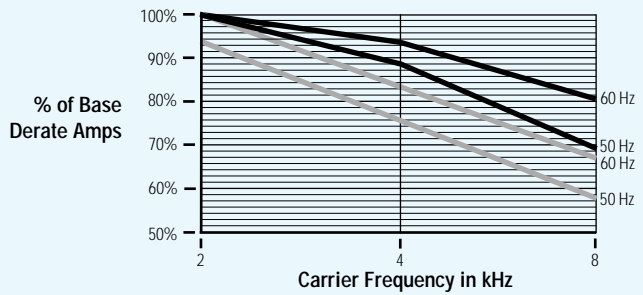
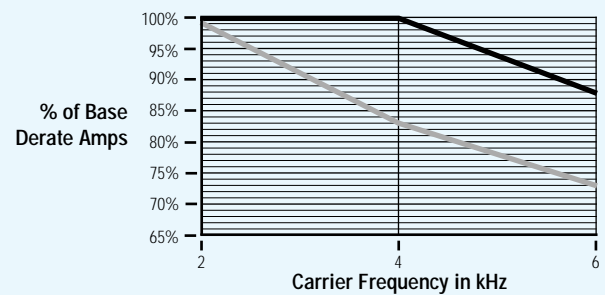

Figure 16

C150C — 112 kW (150 HP), 575V AC (CT)

— Standard Rating for Enclosed Drive in 40°C Ambient.
 — Derating Factor for Enclosed Drive in 41-50°C Ambient.



Ambient Temperature/Carrier Frequency (CONTINUED)

Figure 17

C200C — 149 kW (200 HP), 575V AC (CT)

- Standard Rating for Enclosed Drive in 40°C Ambient.
- Derating Factor for Enclosed Drive in 41-50°C Ambient.

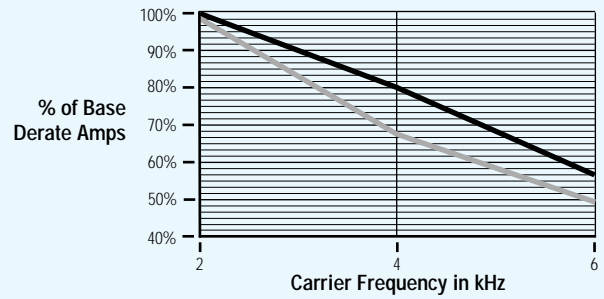

Figure 18

C250C — 187 kW (250 HP), 575V AC (CT)

- Standard Rating for Enclosed Drive in 40°C Ambient.
- Derating Factor for Enclosed Drive in 41-50°C Ambient.

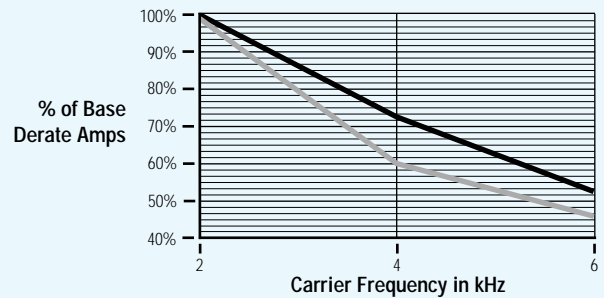

Figure 19

C300C-C600C — 224-448 kW (300-600 HP), 575V AC (CT)
40°C Ambient

- Standard Rating for Enclosed Drive in 40°C Ambient.

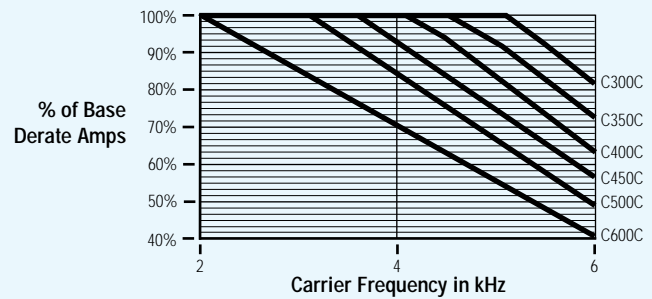

Figure 20

C300C-C600C — 224-448 kW (300-600 HP), 575V AC (CT)
41-50°C Ambient

- Derating Factor for Enclosed Drive in 41-50°C Ambient.

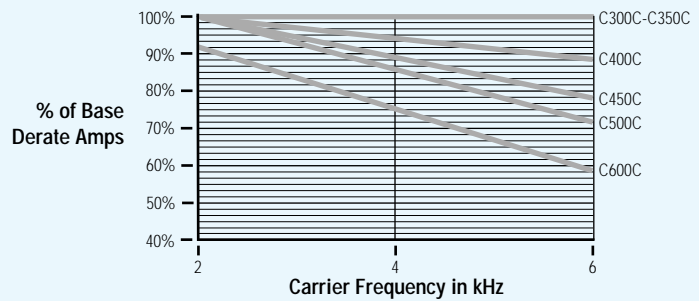
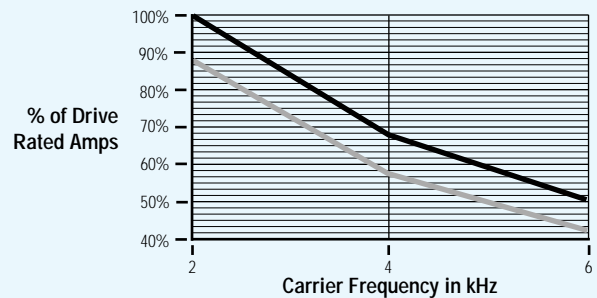

Figure 21

1336S-CX300C

- Standard Rating for Enclosed Drive in 40°C Ambient.
- Derating Factor for Enclosed Drive in 41-50°C Ambient.



Altitude

Figure 22
All Drive Ratings

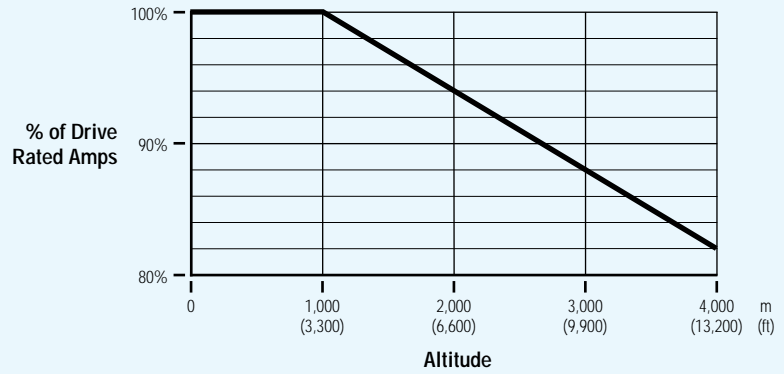

High Input Voltage

Figure 23
Required Only
for the following drives:
18.5 kW (25 HP) drives at 8 kHz (230 or 575V)
All 22 kW (30 HP) drives at 6 or 8 kHz (All Voltages)
45 kW (60 HP) drives at 6 kHz (575V)

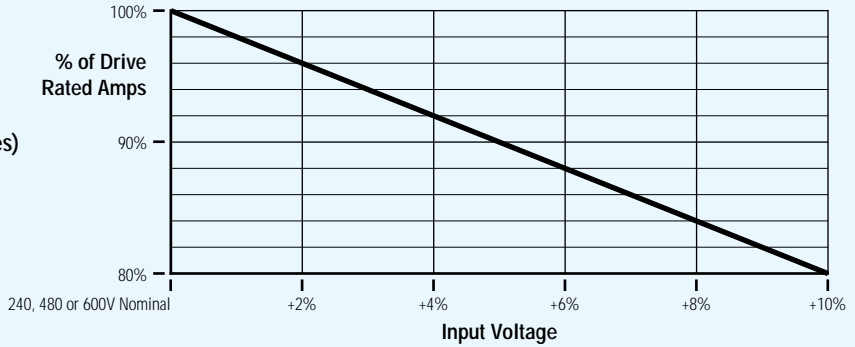

1336 PLUS CONFIGURED DRIVE SELECTION GUIDE



Base Drive

1336S – B 020 C – AA

Product Bulletin No.

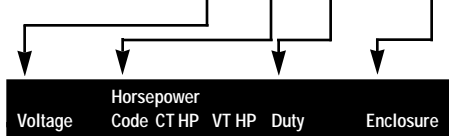

Options as Required

– BM – GM1 – HA1C – . . .

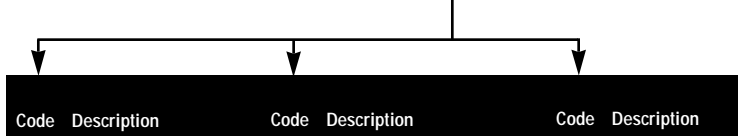

The chart shown on the next page details the segments that make up a Configured Drive Catalog Number. This chart should be used to understand the scope of the overall product offering and assembling a specific catalog number. Care should be taken to verify that the assembled catalog number qualifies as an available configuration by referring to all pages of this section.

Voltage	Horsepower			Duty	Enclosure
	Code	CT	HP		
A = 230V AC	F05	0.5	0.5	C = Constant Torque	AA = NEMA Type 1
	F07	0.75	0.75		
	F10	1	1		
	F15	1.5	1.5		AF = NEMA Type 4
	F20	2	2		
	F30	3	3		
	F50	5	5		AJ = NEMA Type 12
	007	7.5	7.5		
	010	10	10		
	015	15	15		
	020	20	20		
	025	25	25		
	030	30	30		
	040	40	40		
	050	50	50		
	060	60	60		
	075	75	75		
	100	100	100		
125	125	125			
B = 460V AC	F05	0.5	0.5	C = Constant Torque	AA = NEMA Type 1
	F07	0.75	0.75		
	F10	1	1		
	F15	1.5	1.5		AF = NEMA Type 4
	F20	2	2		
	F30	3	3		
	F50	5	5		AJ = NEMA Type 12
	F75	7.5	10		
	F100	10	15		
	X007	—	7.5		
	007	7.5	10		
	010	10	15		
	015	15	20		
	020	20	25		
	025	25	—		
	030	30	30		
	X040	40	40		
	040	—	50		
	050	50	—		
	X060	60	60		
	060	60	75		
	075	75	100		
	100	100	125		
	125	125	150		
	X150	150	—		
	150	150	200		
	200	200	250		
	250	250	250		
	P250	250	300		
	X250	—	300		
300	300	350			
P300	300	350			
350	350	400			
P350	350	400			
400	400	450			
P400	400	450			
450	450	500			
P450	450	—			
500	500	600			
600	600	—			
C = 575V AC	F10	1	1	C = Constant Torque	AA = NEMA Type 1
	F20	2	2		
	F30	3	3		
	F50	5	5		AF = NEMA Type 4
	007	7.5	7.5		
	010	10	10		
	015	15	15		AJ = NEMA Type 12
	020	20	20		
	025	25	25		
	030	30	30		
	040	40	40		
	050	50	50		
	060	60	60		
	075	75	75		
	100	100	100		
	125	125	125		
	150	150	150		
	200	200	200		
250	250	250			
300	300	300			
350	350	350			
400	400	400			
450	450	450			
500	500	500			
600	600	600			

Code	Description	Code	Description	Code	Description
-BA	Bypass, Auto	-EB	Voltage Barrier	-JR	Contacts, Run
-BC	Bypass, Auto, SMC-Pump	-EC	Enclosure Filtered Door Openings	-JR	Contacts, Door Openings
-BD	Bypass, Auto, SMC	-EF1	Enclosure Floor Stand, 12"	-JS	SLC Hardware & Mounting
-BM	Bypass, Manual	-EF2	Enclosure Floor Stand, 24"	-JT	Contacts, At Speed
-BP	Bypass, Manual, SMC-Pump	-EG	Enclosure Filters and Gasketing	-KD	Contact, Drive Input 2
-BS	Bypass, Manual, SMC	-EH	Enclosure Heater	-KM	Contact, Drive Output
-CB	Circuit Breaker, Drive	-ENC	Language MOD - English	-L4C	Control Interface, TTL
-CC	Circuit Breaker, Bypass	-EP	Enclosure Paint - Special	L4EC	Control Int, TTL, Encoder
-CF	Control Power - Drive Only	-ESC	Language MOD - Spanish	-L5C	Control Interface, 24V
-CM	Common Mode Core	-ET	Enclosure Nameplate	-L5EC	Control Int, 24V, Encoder
-CP	Control Power Plus 250VA	-FM	Fuse Block, Motor	-L6	Control Interface, 115V AC (Std.)
-CT	Control Power. Plus 500VA	-FRC	Language Mod.-French	-L6EC	Control Int, 115V, Encoder
-DEC	Language Module - German	-GM1C	Single Point RIO	-LR	Input Reactor, NEMA 1
-DS	Disconnect Switch, Drive	-GM2C	RS232/422/485, DFI	-LT	Input Reactor, NEMA 4/12
-DT	Disconnect Switch, Bypass	-GM5C	DeviceNet	-LQ	Output Reactor, NEMA 1
-D10	Start, Stop, Jog, A/M	-GD1C	Single Point RIO	-LW	Output Reactor, NEMA 4/12
-D11	H/O/A and A/M Switches	-GD2C	RS232/422/485, DF1	-MB	Blower Motor Starter
-D12	D11 Plus Pilot Lights	-HABC	HIM, Blank, NEMA Type 1	-MC	Custom Meter
-D13	H/O/A Selector Switch	-HAPC	HIM, Programmer, NEMA Type 1	-ME	Elapsed Time Meter
-D14	D13 Plus Pilot Lights	-HA1C	HIM, Analog, NEMA Type 1	-MH	Motor Heater Control
-D15	A/M Selector Switch	-HA2C	HIM, Digital, NEMA Type 1	-MK	Thermal Overload-Class 20
-D16	D15 Plus Pilot Lights	-HJPC	HIM, Programmer, NEMA Type 12	-MQ	Line Metering System
-D17	Start & Stop PBs	-HJ2C	HIM, Digital, NEMA Type 1	-MT	Thermal Overload-Class 10
-D18	Start, Stop A/M	-HJPEC	G.P.T. Programmer	-N2	Analog Output Isolator
-D19	Start, Stop, Jog	-HJ3EC	G.P.T. W/Run Time	-N3	Analog Input Isolator
-D21	Pilot Light Package	-HNBC	HIM, Blank, Open	-N4C	Transducer, Local Command
-D22	Pilot Light Package	-HNPC	HIM, Programmer, Open	-N4T	Transducer, Local Trim
-D31	At Speed Pilot Light	-HN1C	HIM, Analog, Open	-N5C	Transducer, Remote Command
-D32	Fwd/Rev Selector Switch	-HN2C	HIM, Digital, Open	-N5T	Transducer, Remote Trim
-D41	Drive & Bypass Lights	-ITC	Language Module, Italian	-N6	RTD Protection, 120 Ohm NiKel
D42	Auto Bypass Enable Off/On S.S. and Bypass P.L.	-JA	Analog Outputs, 4-20MA	-N7	RTD Protection 10 Ohm Copper
-D51	Drive Disable PB (Contactor)	-JC	Contacts, Control Power On	-N8	RTD Protection, 100 Ohm Platinum
-D52	Drive Disable PB (Enable)	-JF	Contacts, Fault	-N9	Thermistor Sensing Relay
D61	Speed Pot, NEMA Type 1	-JL	PLC Hardware & Mounting		
-D91	800T Conversion	-JM	Contacts, Alarm		

NOTE: Not all options are available with all ratings.

- All Base Drives listed on the following pages include:
- A Standard Drive
 - For 230 & 460V Drives, an English/English Language Module -ENC
 - For 575V Drives, an English/French Language Module -FRC
 - Drive Branch Fusing
 - A 115V AC Control Interface Card (Option -L6)
 - Enclosure

230V Constant and Torque Drives and Enclosures ^{1, 2}

Frame	Drive Rating Nominal HP	Amps	NEMA Type 1 (IP20) General Purpose Code	NEMA Type 4 (IP56) Resists Water and Dust Code	NEMA Type 12 (IP54) Industrial Use, Dust Tight Code
A1	1/2	2.3	AF05C-AA	AF05C-AF	AF05C-AJ
	3/4	3.0	AF07C-AA	AF07C-AF	AF07C-AJ
	1	4.5	AF10C-AA	AF10C-AF	AF10C-AJ
A2	1 1/2	6.0	AF15C-AA	AF15C-AF	AF15C-AJ
	2	8.0	AF20C-AA	AF20C-AF	AF20C-AJ
A3	3	12.0	AF30C-AA	AF30C-AF	AF30C-AJ
	5	18.0	AF50C-AA	AF50C-AF	AF50C-AJ
B1	7 1/2	27.0	A007C-AA	A007C-AF	A007C-AJ
B2	10	34.0	A010C-AA	A010C-AF	A010C-AJ
	15	48.0	A015C-AA	A015C-AF	A015C-AJ
C	20	65.0	A020C-AA	A020C-AF	A020C-AJ
	25	77.0	A025C-AA	A025C-AF	A025C-AJ
	30	80.0	A030C-AA	A030C-AF	A030C-AJ
D	40	120.0	A040C-AA	A040C-AF	A040C-AJ
	50	150.0	A050C-AA	A050C-AF	A050C-AJ
	60	180.0	A060C-AA	A060C-AF	A060C-AJ
E	75	240.0	A075C-AA	A075C-AF	A075C-AJ
	100	292.0	A100C-AA	A100C-AF	A100C-AJ
	125	325.0	A125C-AA	A125C-AF	A125C-AK

460V Constant Torque Drives and Enclosures ^{1, 3}

Frame	Drive Rating Nominal HP	Amps	NEMA Type 1 (IP20) General Purpose Code	NEMA Type 4 (IP56) Resists Water and Dust Code	NEMA Type 12 (IP54) Industrial Use, Dust Tight Code
A1	1/2	1.1	BF05C-AA	BF05C-AF	BF05C-AJ
	3/4	1.6	BF07C-AA	BF07C-AF	BF07C-AJ
	1	2.1	BF10C-AA	BF10C-AF	BF10C-AJ
	1 1/2	2.8	BF15C-AA	BF15C-AF	BF15C-AJ
A2	2	3.8	BF20C-AA	BF20C-AF	BF20C-AJ
	3	5.3	BF30C-AA	BF30C-AF	BF30C-AJ
A3	5	8.4	BF50C-AA	BF50C-AF	BF50C-AJ
A4	7 1/2	14.0	BF75C-AA	BF75C-AF	BF75C-AJ
	10	17.5	BF100C-AA	BF100C-AF	BF100C-AJ
B1	7 1/2	12.5	B007C-AA	B007C-AF	B007C-AJ
	10	16.1	B010C-AA	B010C-AF	B010C-AJ
	15	24.2	B015C-AA	B015C-AF	B015C-AJ
B2	20	31.0	B020C-AA	B020C-AF	B020C-AJ
	25	39.0	B025C-AA	B025C-AF	B025C-AJ
	30	45.0	B030C-AA	B030C-AF	B030C-AJ
C	40	59.0	B040C-AA	B040C-AF	B040C-AJ
	50	75.0	B050C-AA	B050C-AF	B050C-AJ
	60	77.0	BX060C-AA	BX060C-AF	BX060C-AJ
D	60	85.0	B060C-AA	B060C-AF	B060C-AJ
	75	106.0	B075C-AA	—	B075C-AJ
	100	138.0	B100C-AA	—	B100C-AJ
	125	173.0	B125C-AA	—	B125C-AJ
	150	180.0	BX150C-AA	—	BX150C-AJ
E	150	199.0	B150C-AA	—	B150C-AJ
	200	263.0	B200C-AA	—	B200C-AJ
	250	325.0	B250C-AA	—	B250C-AJ
F	250	325.0	BP250C-AA	—	BP250C-AJ
	300	360.0	BP300C-AA	—	BP300C-AJ
	350	425.0	BP350C-AA	—	BP350C-AJ
	400	475.0	BP400C-AA	—	BP400C-AJ
	450	527.0	BP450C-AA	—	—
G	300	360.0	B300C-AA	—	B300C-AJ
	350	425.0	B350C-AA	—	B350C-AJ
	400	475.0	B400C-AA	—	B400C-AJ
	450	525.0	B450C-AA	—	—
	500	590.0	B500C-AA	—	—
	600	670.0	B600C-AA	—	—

¹ The basic drive does not include a Control Power Transformer. If local 115V AC power is not available, refer to options CF, CP and CT.

² The drive rating is based on a nominal voltage of 240 volts and a carrier frequency of 4kHz at altitudes of 1,000 meters or less. Refer to the Drive Derating Guidelines on pages 69-75 for derating information.

³ The drive rating is based on a nominal voltage of 480 volts and a carrier frequency of 4kHz at altitudes of 1,000 meters or less. Refer to the Drive Derating Guidelines on pages 69-75 for derating information.

460V Variable Torque Drives and Enclosures ^{1, 2, 4}

Frame	Drive Rating Nominal HP	Amps	NEMA Type 1 (IP20) General Purpose Code	NEMA Type 4 (IP56) Resists Water and Dust Code	NEMA Type 12 (IP54) Industrial Use, Dust Tight Code
A1	1/2	1.2	BF05V-AA	BF05V-AF	BF05V-AJ
	3/4	1.7	BF07V-AA	BF07V-AF	BF07V-AJ
	1	2.3	BF10V-AA	BF10V-AF	BF10V-AJ
	1 1/2	3.0	BF15V-AA	BF15V-AF	BF15V-AJ
A2	2	4.0	BF20V-AA	BF20V-AF	BF20V-AJ
	3	6.0	BF30V-AA	BF30V-AF	BF30V-AJ
A3	5	9.0	BF50V-AA	BF50V-AF	BF50V-AJ
A4	10	17.5	BF75V-AA	BF75V-AF	BF75V-AJ
	15	25.0	BF100V-AA	BF100V-AF	BF100V-AJ
B1	7 1/2	12.5	BX007V-AA	BX007V-AF	BX007V-AJ
	10	14.0	B007V-AA	B007V-AF	B007V-AJ
	15	21.0	B010V-AA	B010V-AF	B010V-AJ
B2	20	27.0	B015V-AA	B015V-AF	B015V-AJ
	25	34.0	B020V-AA	B020V-AF	B020V-AJ
	30	48.0	B030V-AA	B030V-AF	B030V-AJ
C	40	59.0	BX040V-AA	BX040V-AF	BX040V-AJ
	50	65.0	B050V-AA	B050V-AF	B050V-AJ
	60	77.0	BX060C-AA	BX060V-AF	BX060V-AJ
D	75	96.0	B060V-AA	—	B060V-AJ
	100	120	B075V-AA	—	B075V-AJ
	125	150	B100V-AA	—	B100V-AJ
	150	180	BX125V-AA	—	BX125V-AJ
E	200	240	B150V-AA	—	B150V-AJ
	250	292	B200V-AA	—	B200V-AJ
	250	325	B250V-AA	—	B250V-AJ
F	300	360	BP250V-AA	—	BP250V-AJ
	350	425	BP300V-AA	—	BP300V-AJ
	400	475	BP350V-AA	—	BP350V-AJ
	450	532	BP400V-AA	—	BP400V-AJ
G	300	360	BX250V-AA	—	BX250V-AJ
	350	425	B300V-AA	—	B300V-AJ
	400	475	B350V-AA	—	B350V-AJ
	450	525	B400V-AA	—	B400V-AJ
	500	590	B450V-AA	—	—
	600	670	B500V-AA	—	—

575V Constant and Variable Torque Drives and Enclosures ^{1, 3}

Frame	Drive Rating Nominal HP	Amps	NEMA Type 1 (IP20) General Purpose Code	NEMA Type 4 (IP56) Resists Water and Dust Code	NEMA Type 12 (IP54) Industrial Use, Dust Tight Code
A4	1	2.0	CF10C-AA	CF10C-AF	CF10C-AJ
	2	4.0	CF20C-AA	CF20C-AF	CF20C-AJ
	3	6.0	CF30C-AA	CF30C-AF	CF30C-AJ
	5	8.0	CF50C-AA	CF50C-AF	CF50C-AJ
B1	7 1/2	10.0	C007C-AA	C007C-AF	C007C-AJ
	10	12.0	C010C-AA	C010C-AF	C010C-AJ
B2	15	19.0	C015C-AA	C015C-AF	C015C-AJ
	20	24.0	C020C-AA	C020C-AF	C020C-AJ
C	25	30.0	C025C-AA	C025C-AF	C025C-AJ
	30	35.0	C030C-AA	C030C-AF	C030C-AJ
	40	45.0	C040C-AA	C040C-AF	C040C-AJ
	50	57.0	C050C-AA	C050C-AF	C050C-AJ
	60	62.0	C060C-AA	C060C-AF	C060C-AJ
D	75	85.0	C075C-AA	—	C075C-AJ
	100	109	C100C-AA	—	C100C-AJ
	125	138	C125C-AA	—	C125C-AJ
E	150	168	C150C-AA	—	C150C-AJ
	200	252	C200C-AA	—	C200C-AJ
	250	284	C250C-AA	—	C250C-AJ
	300	300	CX300C-AA	—	CX300C-AJ
G	300	300	C300C-AA	—	C300C-AJ
	350	350	C350C-AA	—	C350C-AJ
	400	400	C400C-AA	—	C400C-AJ
	450	450	C450C-AA	—	—
	500	500	C500C-AA	—	—
	600	600	C600C-AA	—	—

¹ The basic drive does not include a Control Power Transformer. If local 115V AC power is not available, refer to options **CF**, **CP** and **CT**.

² The drive rating is based on a nominal voltage of 480 volts and a carrier frequency of 4kHz at altitudes of 1,000 meters or less. Refer to the Drive Derating Guidelines on pages 69-75 for derating information.

³ The drive rating is based on a nominal voltage of 600 volts and a carrier frequency of 4kHz at altitudes of 1,000 meters or less. Refer to the Drive Derating Guidelines on pages 69-75 for derating information.

⁴ When choosing horsepower related options for variable torque drives, match the option to the actual variable torque horsepower rating, not to the base catalog number. **Example:** A 15 HP VT Drive requires a 15 HP Circuit Breaker, not a 10 HP Circuit Breaker.

Motor Thermal Overload Relay Selection

Class 10 (Bulletin 193) Relays:

- Trip in 10 seconds or less at 600% of device current rating.
- Have integral heater elements — Additional heater elements are not required.
- Have auto or manual reset.
- Have trip settings per the range chart shown below

Note: Ranges shown are based on a 1.15 motor service factor or greater. For motors with 1.0 service factors or values outside the listed range, complete motor data must be supplied at order entry.

Option Rating HP (kW)	Class 10 Adjustable Thermal Overload Relay Ranges ¹ — Option Code -MT			
	230V	460V-CT	Adjustable Range 460V-VT	575V
0.5 (0.37)	2-3 A	1-1.6 A	1-1.6 A	N/A
0.75 (0.56)	2.8-4.2 A	1.5-2.3 A	1.5-2.3 A	N/A
1 (0.75)	4-6 A	2-3 A	2-3 A	1.5-2.3 A
1.5 (1.2)	5.5-8 A	2-3 A	2.8-4.2 A	N/A
2 (1.5)	6-10 A	2.8-4.2 A	2.8-4.2 A	2.8-4.2 A
3 (2.2)	10-16 A	4-6 A	5.5-8 A	5.5-8 A
5 (3.7)	16-24 A	6-10 A	10-16 A	6-10 A
7.5 (5.5)	22-32 A	10-16 A	10-16 A	6-10 A
10 (7.5)	30-45 A	16-24 A	10-16 A (B007V) 16-24 A (BF75V)	10-16 A
15 (11)	45-60 A	22-32 A	16-24 A (B010V) 22-32 A (BF100V)	16-24 A
20 (15)	60-75 A	30-45 A	22-32 A	16-24 A
25 (18.5)	66-110 A	30-45 A	30-45 A	22-32 A
30 (22)	66-110 A	30-45 A	45-60 A	30-45 A
40 (30)	120-200 A	45-60 A	45-60 A	30-45 A
50 (37)	120-200 A	60-75 A	60-75 A	45-60 A
60 (45)	120-200 A	66-110 A	66-110 A	60-75 A
75 (56)	180-300 A	66-110 A	66-110 A	66-110 A
100 (75)	180-300A	120-200 A	80-120 A	66-110 A
125 (93)	240-400 A	120-200 A	120-200 A	120-200 A
150 (112)	—	120-200 A	120-200 A	120-200 A
200 (149)	—	180-300 A	180-300 A	180-300 A
250 (187)	—	240-400 A	180-300 A (B200V) 240-400 A (B250V)	180-300 A
300 (224)	—	240-400 A	240-400 A	180-300 A
350 (261)	—	378-630 A	378-630 A	240-400 A
400 (298)	—	378-630 A	378-630 A	240-400 A
450 (336)	—	378-630 A	378-630 A	378-630 A
500 (373)	—	378-630 A	378-630 A	378-630 A
600 (448)	—	645-975 A	645-975 A	378-630 A

Class 20 (Bulletin 592) Relays:

- Trip in 20 seconds or less at 600% of device current rating.
- Must Be manually reset.
- Can be programmed for Class 20 operation by choosing the appropriate heater elements from the A-B Industrial Control Catalog — **Publication A111.**
- Can also be programmed for Class 10 and 30 operation by choosing the appropriate heater elements from the chart on **page 81** or by referencing the A-B Industrial Control Catalog — **Publication A111.**

¹ Adjustable ranges are based upon average requirements for Bulletin 1329 AC Motors and do not necessarily cover the maximum drive current capability.

Heater Element Selection

The **Thermal Overload Relay** (Option MK) will require the addition of a thermal overload heater element. These elements are not available as part of the Configured Drives Program. The Class 20 chart shown below is supplied for reference purposes only. If Class 10 or 30 operation is required, refer to the A-B Industrial Control Catalog — **Publication A111** for selection guidance.

Rating	Motor Full Load Amperes for Sizing of Class 20 Heater Elements for Various Options Drive Ratings in kW (HP)									Heater Type W Number
	0.37-3.7 (0.5-5)	5.5-7.5 (7.5-10)	11-18.5 (15-25)	22-37 (30-50)	45 (60)	56-75 (75-100)	93 (125)	—	261-373 (350-500)	
230V	0.37-3.7 (0.5-5)	5.5-7.5 (7.5-10)	11-18.5 (15-25)	22-37 (30-50)	45 (60)	56-75 (75-100)	93 (125)	—	261-373 (350-500)	W20
460V-CT	0.37-3.7 (0.5-5)	5.5-18.5 (7.5-25)	22-30 (30-40)	37-75 (50-100)	93-112 (125-150)	149-187 (200-250)	224 (300)	261-373 (350-500)	261-373 (350-500)	W21
460V-VT	0.37-3.7 (0.5-5)	5.5-18.5 (7.5-25)	22-30 (30-40)	37-75 (50-100)	93-112 (125-150)	149-187 (200-250)	224 (300)	261-373 (350-500)	261-373 (350-500)	W22
575V	0.37-3.7 (0.5-5)	5.5-22 (7.5-30)	30-45 (40-60)	56-93 (75-125)	112 (150)	149-224 (200-300)	261-336 (350-450)	373 (500)	373 (500)	W23
W20	0.49	W20
W21	0.54	W21
W22	0.60	W22
W23	0.67	70	W23
W24	0.74	75	127	W24
W25	0.84	W25
W26	0.90	115	...	W26
W27	1.00	43	...	78	125	...	W27
W28	1.10	45	...	85	135	...	W28
W29	1.22	50	...	94	147	...	W29
W30	1.31	54	...	104	165	...	W30
W31	1.43	59	...	114	179	...	W31
W32	1.55	65	...	125	196	...	W32
W33	1.66	70	...	139	216	...	W33
W34	1.80	75	127	150	232	...	W34
W35	1.97	81	138	160	260	...	W35
W36	2.12	89	151	175	287	...	W36
W37	2.33	98	166	195	315	...	W37
W38	2.59	110	183	215	350	...	W38
W39	2.84	120	198	235	385	...	W39
W40	3.15	132	218	260	420	...	W40
W41	3.46	143	239	298	465	...	W41
W42	3.84	155	260	320	515	...	W42
W43	4.27	170	285	350	570	...	W43
W44	4.73	193	310	380	630	...	W44
W45	5.36	415	W45
W46	5.82	455	W46
W47	6.33	500	W47
W48	6.97	550	W48
W49	7.63	W49
W50	8.49	8.45	W50
W51	9.24	9.29	W51
W52	10.1	10.3	W52
W53	11.1	11.4	W53
W54	12.2	12.5	W54
W55	13.6	13.7	W55
W56	14.6	15.0	W56
W57	15.7	16.3	W57
W58	17.2	17.6	W58
W59	18.9	18.9	W59
W60	20.5	20.9	21.1	W60
W61	22.2	22.9	23.2	25.1	W61
W62	24.3	25.0	25.7	27.5	W62
W63	...	27.6	28.5	30.5	W63
W64	...	30.0	30.5	33.5	W64
W65	...	32.0	33.0	36.5	W65
W66	...	34.0	35.5	40.0	43.0	W66
W67	...	37.0	38.5	44.0	47.0	W67
W68	...	39.0	41.5	48.5	51	W68
W69	...	41.0	45.0	53	56	W69
W70	48.5	58	61	W70
W71	53	62	66	W71
W72	56	67	72	W72
W73	58	72	77	W73
W74	60	77	83	W74
W75	62	82	89	W75
W76	88	95	W76
W77	94	102	W77
W78	98	108	W78
W79	102	116	W79
W80	108	123	W80
W81	117	130	W81
W82	125	137	W82
W83	150	W83
W84	160	W84
W85	165	W85

Table 181¹

Table 195¹

¹ Heater element selection tables taken from A-B Industrial Control Catalog — **Publication A111**.

Option Kits Not Factory Mounted

LANGUAGE MODULE KITS (For Customer Installation)		
Description ¹	Used With . . .	Catalog Number (Loose Kit)
Language Modules	All 1336S Drive Ratings	
English/English		1336S-EN
English/French		1336S-FR
English/German		1336S-DE
English/Italian		1336S-IT
English/Spanish		1336S-ES

DYNAMIC BRAKE KITS (For Customer Installation)		
Description ¹	Used With . . . ²	Catalog Number (Loose Kit)
Dynamic Braking, Heavy Duty 230V AC	5 HP Maximum	1336-MOD-KA005
	10 HP Maximum	1336-MOD-KA010 ⁺
Dynamic Braking, Heavy Duty 460V AC	5 HP Maximum	1336-MOD-KB005
	10 HP Maximum	1336-MOD-KB010
	50 HP Maximum	1336-MOD-KB050
Dynamic Braking, Heavy Duty 575V AC	5 HP Maximum	1336-MOD-KC005
	10 HP Maximum	1336-MOD-KC010
	50 HP Maximum	1336-MOD-KC050

COMMUNICATION OPTION KITS (For Customer Installation)		
Description ¹	Used With . . .	Catalog Number (Loose Kit)
Remote Mounted with Integral 115V AC Power Supply Single Point RIO RS232/422/485, DF1 and DH485 Protocol	All 1336S Drive Ratings	1203-GD1 ³ 1203-GD2 ³
Remote Mounted for Use with 24V DC Power Supply Single Point RIO RS232/422/485, DF1 and DH485 Protocol	All 1336S Drive Ratings	1203-GM1 ³ 1203-GM2 ³
Communication Option Cable Kits (1/2) Meter Length (1) Meter Length (3) Meter Length (9) Meter Length	All Communications Options Listed Above	1202-C03 1202-C10 1202-C30 1202-C90
Port Expander, 1-to-2	All 1336S Drive Ratings	1203-SG2
Drive Mounted and Drive Powered Single Point RIO RS232/422/485, DF1 and DH485 Protocol	7 1/2-600 HP 1336S Drives Frame Designations B, C, D, E, F and G	1336-GM1 ⁴ 1336-GM2 ⁴

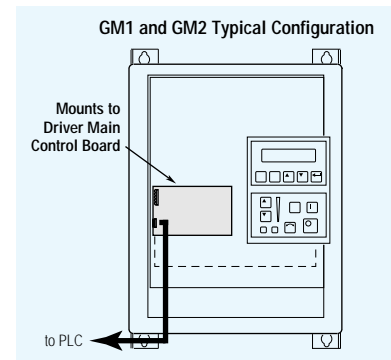
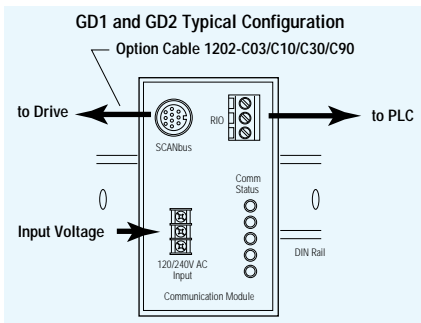

¹ For a more functionally complete description of each option refer to Publication 1336 PLUS-1.0.
² Multiple kits may be utilized together to obtain higher HP ratings. Refer to Publication 1336-5.64 for guidance.
³ Requires a Communication Option Cable (1202-C03/C10/C30/C90) to be functional.
⁴ A maximum of (1) Communication Option may be drive mounted.

Option Kits Not Factory Installed

LINE REACTORS AND ISOLATION TRANSFORMERS (For Remote Customer Mounting)

Line Reactor Specifications:

Iron core, 3% impedance, 600V, Class H insulation, 115°C rise, copper wound, 50/60 Hz
 Terminal blocks on terminal blocks 80A and below.
 Copper box lugs on terminal blocks 80A and below.
 UL, CSA.

Isolation Transformer Specifications:

230V/230V or 460V/460V Delta PRI/Wye secondary, Class H insulation, , 115°C rise, aluminum wound, 60 Hz, ±5% taps, (1) N.C. thermostat per coil, UL, CSA.

230V AC LINE

Rating kW (HP)	Input Line Reactor		Isolation Transformer NEMA Type 1 (IP20) Catalog Number
	Open Style (IP00) Catalog Number	NEMA Type 1 (IP20) Catalog Number	
0.37 (0.5)	1321-3R4-A	1321-3RA4-A	1321-3T003-AA
0.56 (0.75)	1321-3R4-A	1321-3RA4-A	1321-3T003-AA
0.75 (1)	1321-3R8-A	1321-3RA8-A	1321-3T005-AA
1.2 (1.5)	1321-3R8-A	1321-3RA8-A	1321-3T005-AA
1.5 (2)	1321-3R8-A	1321-3RA8-A	1321-3T005-AA
2.2 (3)	1321-3R18-A	1321-3RA18-A	1321-3T005-AA
3.7 (5)	1321-3R18-A	1321-3RA18-A	1321-3T007-AA
5.5 (7.5)	1321-3R35-A	1321-3RA35-A	1321-3T011-AA
7.5 (10)	1321-3R35-A	1321-3RA35-A	1321-3T014-AA
11 (15)	1321-3R55-A	1321-3RA55-A	1321-3T020-AA
15 (20)	1321-3R80-A	1321-3RA80-A	1321-3T027-AA
18.5 (25)	1321-3R100-A	1321-3RA100-A	1321-3T034-AA
22 (30)	1321-3R100-A	1321-3RA100-A	1321-3T040-AA
30 (40)	1321-3R130-A	1321-3RA130-A	1321-3T051-AA
37 (50)	1321-3R160-A	1321-3RA160-A	1321-3T063-AA
45 (60)	1321-3R200-A	1321-3RA200-A	1321-3T075-AA
56 (75)	1321-3R250-A	1321-3RA250-A	1321-3T093-AA
75 (100)	1321-3R320-A	1321-3RA320-A	1321-3T118-AA
93 (125)	1321-3R400B	1321-3RA400-B	1321-3T145-AA

LINE REACTORS AND ISOLATION TRANSFORMERS (For Remote Customer Mounting) CONTINUED

460V AC LINE

Rating kW (HP)	Input Line Reactor		Isolation Transformer NEMA Type 1 (IP20) Catalog Number
	Open Style (IP00) Catalog Number	NEMA Type 1 (IP20) Catalog Number	
0.37 (0.5)	1321-3R2-B	1321-3RA2-B	1321-3T003-BB
0.56 (0.75)	1321-3R2-B	1321-3RA2-B	1321-3T003-BB
0.75 (1)	1321-3R4-B	1321-3RA4-B	1321-3T005-BB
1.2 (1.5)	1321-3R4-B	1321-3RA4-B	1321-3T005-BB
1.5 (2)	1321-3R4-B	1321-3RA4-B	1321-3T005-BB
2.2 (3)	1321-3R8-B	1321-3RA8-B	1321-3T005-BB
3.7 (5)	1321-3R18-B	1321-3RA18-B	1321-3T007-BB
5.5 (7.5)	1321-3R18-B	1321-3RA18-B	1321-3T011-BB
7.5 (10)	1321-3R35-B	1321-3RA18-B	1321-3T014-BB
11 (15)	1321-3R35-B	1321-3RA35-B	1321-3T020-BB
15 (20)	1321-3R35-B	1321-3RA35-B	1321-3T027-BB
18.5 (25)	1321-3R55-B	1321-3RA55-B	1321-3T034-BB
22 (30)	1321-3R55-B	1321-3RA55-B	1321-3T040-BB
30 (40)	1321-3R80-B	1321-3RA80-B	1321-3T051-BB
37 (50)	1321-3R80-B	1321-3RA80-B	1321-3T063-BB
45 (60)	1321-3R80-B	1321-3RA80-B	1321-3T075-BB
56 (75)	1321-3R160-B	1321-3RA160-B	1321-3T093-BB
75 (100)	1321-3R160-B	1321-3RA160-B	1321-3T118-BB
93 (125)	1321-3R200-B	1321-3RA200-B	1321-3T145-BB
112 (150)	1321-3R250-B	1321-3RA250-B	1321-3T175-BB
149 (200)	1321-3R320-B	1321-3RA320-B	1321-3T220-BB
187 (250)	1321-3R320-B	1321-3RA320-B	1321-3T275-BB
224 (300)	1321-3R400-B	1321-3RA400-B	1321-3T330-BB
261 (350)	1321-3R400-B	1321-3RA400-B	1321-3T440-BB
298 (400)	1321-3R500-B	1321-3RA500-B	1321-3T440-BB
336 (450)	1321-3R600-B	1321-3RA600-B	1321-3T550-BB
373 (500)	1321-3R500-B	1321-3RA500-B	1321-3T550-BB
448 (600)	1321-3R750-B	1321-3RA750-B	1321-3T660-BB

575V AC LINE

Rating kW (HP)	Input Line Reactor		Isolation Transformer NEMA Type 1 (IP20) Catalog Number
	Open Style (IP00) Catalog Number	NEMA Type 1 (IP20) Catalog Number	
0.75 (1)	1321-3R2-B	1321-3RA2-B	1321-3T005-CC
1.5 (2)	1321-3R4-B	1321-3RA4-B	1321-3T005-CC
2.2 (3)	1321-3R8-C	1321-3RA8-C	1321-3T005-CC
3.7 (5)	1321-3R8-B	1321-3RA8-B	1321-3T007-CC
5.5 (7.5)	1321-3R12-B	1321-3RA12-B	1321-3T011-CC
7.5 (10)	1321-3R12-B	1321-3RA12-B	1321-3T014-CC
11 (15)	1321-3R25-B	1321-3RA25-B	1321-3T020-CC
15 (20)	1321-3R25-B	1321-3RA25-B	1321-3T027-CC
18.5 (25)	1321-3R35-B	1321-3RA35-B	1321-3T034-CC
22 (30)	1321-3R35-B	1321-3RA35-B	1321-3T040-CC
30 (40)	1321-3R55-B	1321-3RA55-B	1321-3T051-CC
37 (50)	1321-3R80-B	1321-3RA80-B	1321-3T063-CC
45 (60)	1321-3R80-B	1321-3RA80-B	1321-3T075-CC
56 (75)	1321-3R100-B	1321-3RA100-B	1321-3T093-CC
75 (100)	1321-3R130-B	1321-3RA130-B	1321-3T118-CC
93 (125)	1321-3R160-C	1321-3RA160-C	1321-3T145-CC
112 (150)	1321-3R160-B	1321-3RA160-B	1321-3T175-CC
149 (200)	1321-3R250-B	1321-3RA250-B	1321-3T220-CC
187 (250)	1321-3R320-B	1321-3RA320-B	1321-3T275-CC
224 (300)	1321-3R320-B	1321-3RA320-B	1321-3T330-CC
261 (350)	1321-3R400-B	1321-3RA400-B	1321-3T440-CC
298 (400)	1321-3R400-B	1321-3RA400-B	1321-3T440-CC
336 (450)	1321-3R500-B	1321-3RA500-B	1321-3T550-CC
373 (500)	1321-3R500-B	1321-3RA500-B	1321-3T550-CC
448 (600)	1321-3R600-B	1321-3RA600-B	1321-3T660-CC

Option Selection Reference Chart

Listed in the chart below are possible conflicts that may occur when selecting 1336 PLUS Configured Drive Options.

Selected Option	Must Be Used With . . .	Cannot Be Used With
AA		AF, AJ, HJPC, JH2C
AF		AA, AJ, HABC, HAPC, HA1C, HA2C
AJ		AA, AF, HABC, HAPC, HA1C, HA2C
BA	JF	BC, BD, BM, BP, BS, KM, MK, MT
BC	JF	BA, BD, BM, BP, BS, KM, MK, MT
BD	JF	BA, BC, BM, BP, BS, KM, MK, MT
BM	JF	BA, BC, BD, BP, BS, KM, MK, MT
BP	JF	BA, BC, BD, BM, BS, KM, MK, MT
BS	JF	BA, BC, BD, BM, BP, KM, MK, MT
CB		DS
CC	One of: BA, BC, BD, BM, BP or BS	DT
CF		CP, CT
CM		
CP		CF, CT
CT		CF, CP
DEC		ENC, ESC, FRC, ITC
DS		CB
DT	One of: BA, BC, BD, BM, BP or BS	CC
D10		D11, D19, HA1C, HA2C, HJ2C, HJ3EC
D11		D10, D12, D19
D12		D10, D11, D13, D19
D13		D10-D12, D14-D19
D14		D10-D13, D15-D19
D15		D10-D14, D16-D19
D16		D10-D15, D17-D19
D17		D10-D16, D18, D19, HA1C, HA2C, HF2C, HJ3EC
D18		D10-D17, D19, HA1C, HA2C, HJ2C, HJ3EC
D19		D10-D18, HA1C, HA2C, HJ2C, HJ3EC
D21		D22
D22	One of: BA, BC, BD, BM, BP, BS, MK or MT	D21
D31		D32
D32		D31, BA, BC, BD, BM, BP, BS, CC, DT, FM, HA1C, HJ2C, HF3EC
D41	One of: BA, BC, BD, BM, BP or BS	D42
D42	One of: BA, BC, BD	D41, BM, BP, BS
D51	One of: BA, BC, BD, BM, BP, BS or KM	D52
D52		D51, BA, BC, BD, BM, BP, BS
D61		HA1C, HA2C, HJ2C, HJ3EC
D91	At least one of: D10-D19, D21, D22, D31, D32, D41, D42, D51 or D52	
EB		
EC	AA, Frames D, E & G	AF, AJ, Frames A-C
EF1	Wall Mounting Enclosures	B060C-B600C, B060V-B500V, C075C-C600C, EF2
EF2	Wall Mounting Enclosures	B060C-B600C, B060V-B500V, C075C-C600C, EF1
EH	JR	
ENC		FRC, DEC, ITC, ESC, 230V or 460V Drives
EP		
ESC		ENC, FRC, DEC, ITC
ET		
FM	One of: BA, BC, BD, BM, BP or BS	
FRC		ENC, DEC, ESC, ITC
GD1C		575V Drives
GD2C		GM1C
		GM2C
GM1C		GD1C, GM2C, 0.5-5HP Drives
GM2C		GD2C, GM1C, 0.5-5HP Drives
GM5C		

Selected Option	Must Be Used With . . .	Cannot Be Used With
HABC	AA	AF, AJ, HAPC, HA1C, HA2C, HJPC, HJ2C, HJPEC, HJ3EC
HAPC	AA	AF, AJ, HABC, HA1C, HA2C, HJPC, HJ2C, HJPEC, HJ3EC
HA1C	AA	AF, AJ, D10, D17, D18, D19, HABC, HAPC, HA2C, HJPC, HJ2C, HJPEC, HJ3EC
HA2C	AA	AF, AJ, D10, D17, D18, D19, HABC, HAPC, HA1C, HJPC, HJ2C, HJPEC, HJ3EC
HJPC	AF or AJ	AA, HABC, HAPC, HA1C, HA2C, HJ2C, HJPEC, HJ3EC
HJ2C	AF or AJ	AA, D10, D17, D18, D19, HABC, HAPC, HA1C, HA2C, HJPEC, HJ3EC
HJPEC	AA or AJ	AF, HABC, HAPC, HA1C, HA2C, HJ3EC, HJPC, HJ2C
HJ3EC	AA or AJ	AF, D10, D17, D18, D19, HABC, HAPC, HA1C, HA2C, HJPEC, HJPC, HJ2C
HNBC		HNPC, HN2C
HN2C		HNPC, HN1C, HN2C
HNPC		HNBC, HN1C, HN2C
HN1C		HNBC, HNPC, HN2C
HN2C		HNBC, HNPC, HN1C
ITC		ENC, ESC, FRC, DEC
JA		N2
JC		
JF		
JL		JS
JM		
JR		
JS		JL
JT		
KD		KM
KM	JF	BA, BC, BD, BM, BP, BS, KD
L4C		L4EC, L5C, L5EC, L6EC, D12, D14, D16
L4EC		L4C, L5C, L5EC, L6EC, D12, D14, D16
L5C		L4C, L4EC, L5EC, L6EC
L5EC		D12, D14, D16
L6EC		L4C, L4EC, L5C, L6EC, D12, D14, D16
LQ	AA	L4C, L4EC, L5C, L5EC
LR	AA	AF, AJ, LT, LW
LT	AF or AJ	AA, LR, LQ
LW	AF or AJ	AA, LR, LQ
MB		
MC		
ME	JR	
MH	JR	
MK		BA, BC, BD, BM, BP, BS, MT
MT		BA, BC, BD, BM, BP, BS, MK
MQ		
N2		JA
N3		
N4C		N5C, N5T, N4T
N4T		N5C, N5T, N4C
N5C		N4C, N4T, N5T
N5T		N4C, N4T, N5C
N6		N7, N8, N9
N7		N6, N8, N9
N8		N6, N7, N9
N9		N6, N7, N8

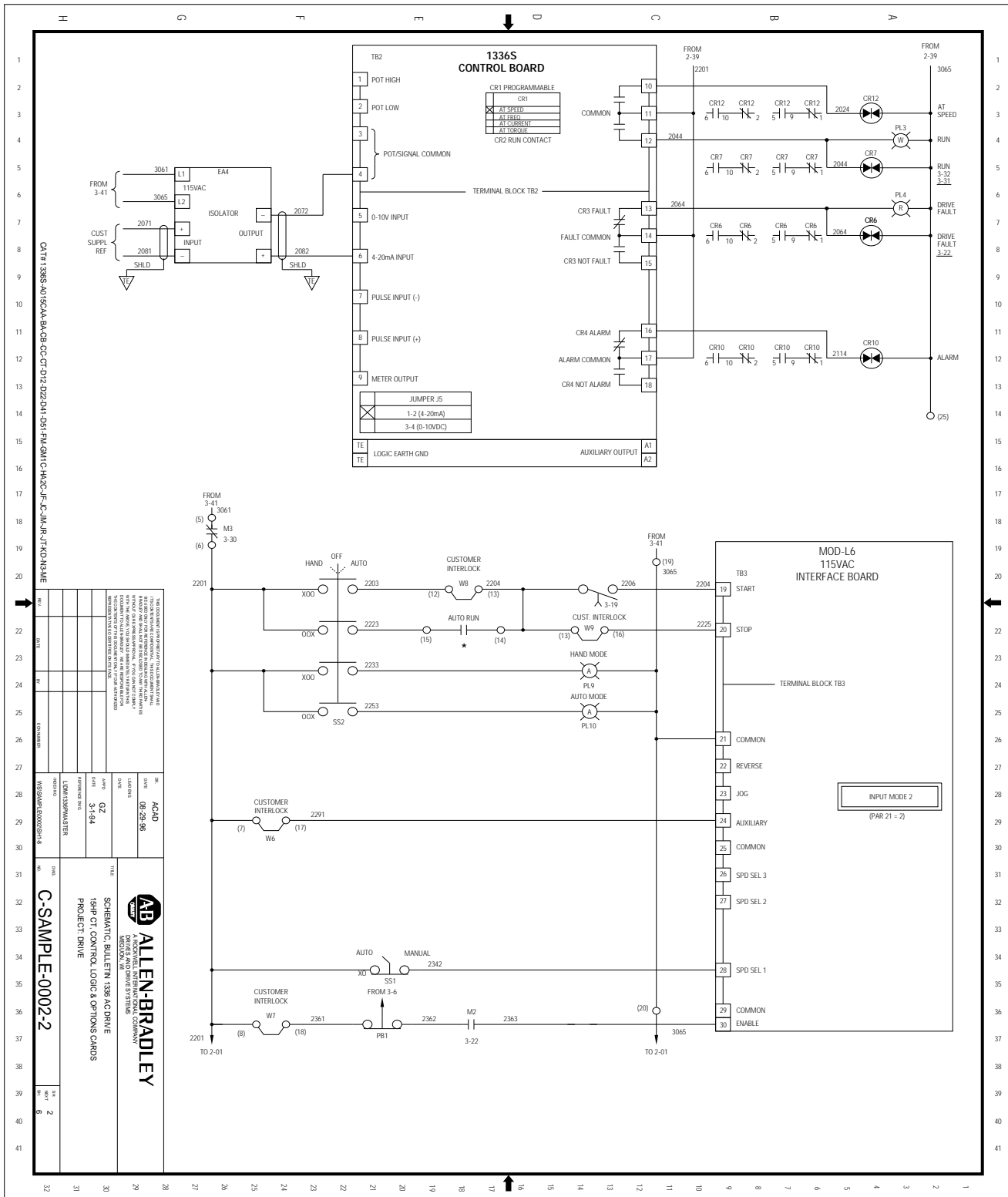

The Control Interface page of the drawings contains the drive main control board and the standard control interface board, as well as all the control logic that interfaces to these two boards. Several customer interlock locations are included in the logic to allow interfacing of extraneous control devices to the existing drive logic.

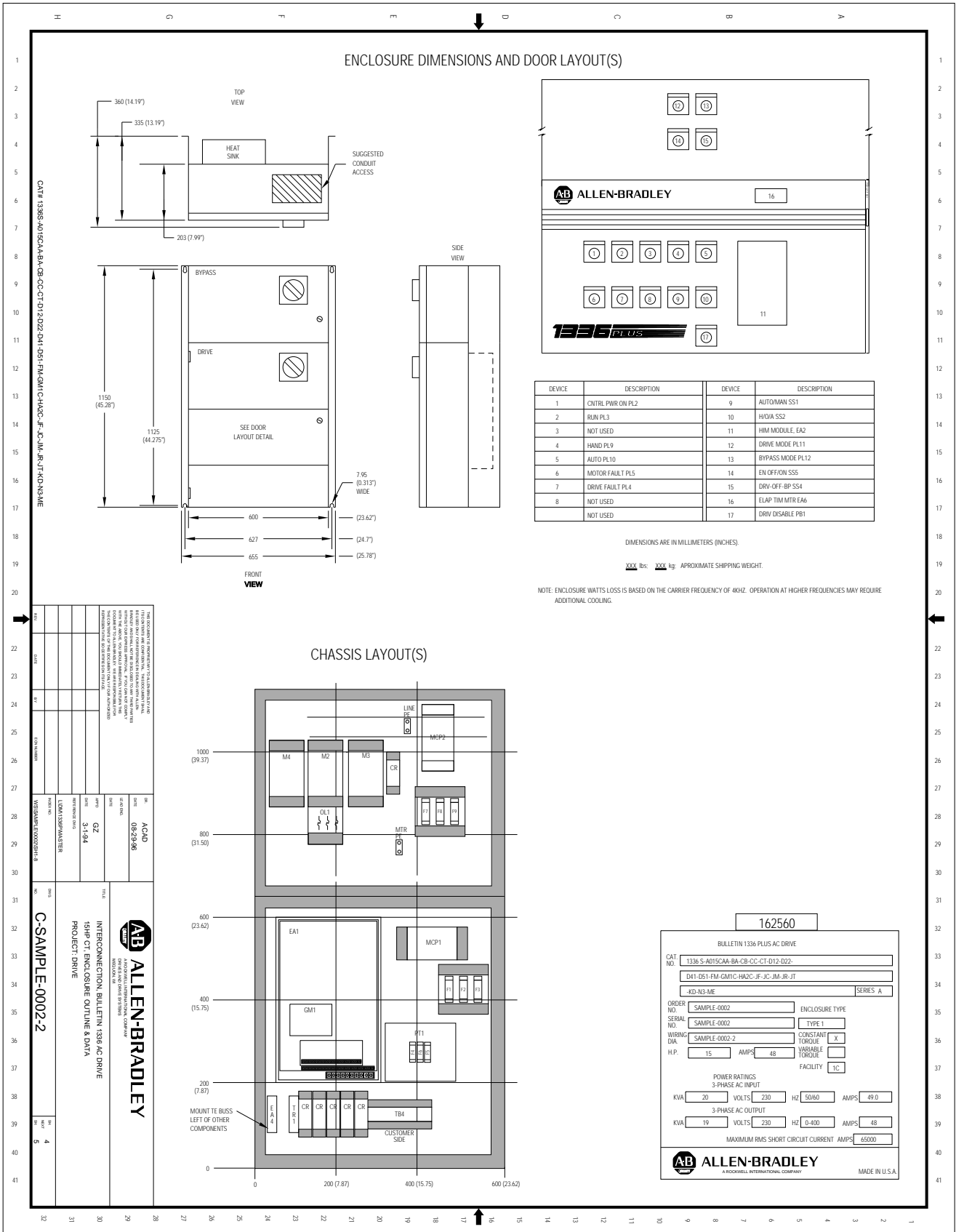

This page of the drawing package provides all the necessary enclosure information including: dimensions, conduit access, operator devices and location, and panel layout. The actual drive system data nameplate is also shown on this sheet – this is helpful for customers who might have multiple drives in one location and need to quickly match up the correct documentation for each drive by comparing nameplates.

MATERIAL LIST — COMPONENTS				EXTERNAL INTERCONNECT WIRING REQUIREMENTS						
				POWER						
				SEE INSTRUCTION MANUAL FOR CABLE CLASSES						
				INTERCONNECTION INFORMATION						
				CURR. CLASS	WIRE	SOURCE	EXPLANATION	TERMINAL WIRE RANGE		
				(AMPS) NO.	(AMPS)					
				2	GRND	LINE-PE	GROUND EOMT CONDUCTOR			
				FRAME MTR-PE						
				SEE MTR						
				2	N/A	1T1	OLT-11	AC MOTOR	#10-4 Ga	
							OLT-12			
							OLT-13			
						FRAME	TB1-PE			
				49	2	65KA	L1	MCP2-L1	INCOMING	#14-4 Ga
							L2	MCP2-L1	230 V LINES	
							L3	MCP2-L3		
				CONTROL						
				SEE INSTRUCTION MANUAL FOR CABLE CLASSES						
				CLASSES 5 AND 6 ARE CONTROL WIRES, 15 AMPS OR LESS						
				INTERCONNECTION INFORMATION						
				CLASS NO.	WIRE NO.	SOURCE	EXPLANATION	TERMINAL WIRE RANGE	CABLE TYPE	
				5	2223	TB4-15	AUTO RUN CONTACT	#18-16 Ga.	PER CODE	
					2204	TB4-14				
				5		CR6-5,9	FAULT NO	#18-16 Ga.	PER CODE	
				5		CR6-9,1	FAULT NC	#18-16 Ga.		
				5		CR6-6,10	FAULT NO	#18-16 Ga.		
						CR6-10,2	FAULT NC	#18-16 Ga.		
				5		CR11-5,9	PWR ON NO	#18-16 Ga.	PER CODE	
				5		CR11-9,1	PWR ON NC	#18-16 Ga.		
				5		CR11-6,10	PWR ON NO	#18-16 Ga.		
						CR11-10,2	PWR ON NC	#18-16 Ga.		
				5		CR10-5,9	ALARM NO	#18-16 Ga.	PER CODE	
				5		CR10-9,1	ALARM NC	#18-16 Ga.		
				5		CR10-6,10	ALARM NO	#18-16 Ga.		
						CR10-10,2	ALARM NC	#18-16 Ga.		
				5		CR7-5,9	RUN NO	#18-16 Ga.	PER CODE	
				5		CR7-9,1	RUN NC	#18-16 Ga.		
				5		CR7-6,10	RUN NO	#18-16 Ga.		
						CR7-10,2	RUN NC	#18-16 Ga.		
				5		CR12-5,9	AT SPD NO	#18-16 Ga.	PER CODE	
				5		CR12-9,1	AT SPD NC	#18-16 Ga.		
						CR12-6,10	AT SPD NO	#18-16 Ga.		
						CR12-10,2	AT SPD NC	#18-16 Ga.		
				SIGNAL						
				SEE INSTRUCTION MANUAL FOR CABLE CLASSES						
				CLASSES 7 THROUGH 12 ARE SIGNAL WIRES, 5 AMPS OR LESS						
				INTERCONNECTION INFORMATION						
				CLASS NO.	WIRE NO.	SOURCE	EXPLANATION	TERMINAL WIRE RANGE	CABLE TYPE	
				7		BD1-1	RI0	#24-18 Ga.	AB	
						BD1-5			1770-CD OR EQUIV	
						BD1-2				
				7		2071	E4A (-)	REMOTE REFERENCE	#24-14 Ga.	
						2081	E4A (-)		BELDEN 8737	
				GENERAL WIRING NOTES						
				<p>1. CUSTOMER TERMINALS ARE SIZED FOR 75°C WIRE PER NEC TABLE 310-16 (75°C)</p> <p>2. STEEL CONDUIT IS RECOMMENDED FOR ALL WIRING CLASSES, BUT IS REQUIRED FOR SIGNAL CATEGORY CLASSES. ALUMINUM CONDUIT REQUIRES THE SAME MINIMUM SPACING AS SHOWN FOR CABLE TRAYS.</p> <p>3. SPACES BETWEEN CLASSES SHOWN IN THE INSTRUCTION MANUAL IS THE MINIMUM REQUIRED FOR PARALLEL RUNS EQUAL TO OR LESS THAN 400 FEET. GREATER SPACING SHOULD BE USED WHERE POSSIBLE.</p> <p>4. NO. 16 GA. WIRE IS THE MINIMUM RECOMMENDED SIZE FOR CONTROL WIRE. POWER WIRE IS SELECTED BY CONTINUOUS MAXIMUM LOAD (FLA).</p> <p>5. SHIELDS FOR SHIELDED CABLE MUST BE CONNECTED AT ONE END ONLY. THE OTHER END SHOULD BE CUT BACK AND INSULATED. IT IS RECOMMENDED THAT SHIELDS FOR SHIELDED CABLE FROM A CABINET TO AN EXTERNAL DEVICE BE CONNECTED AT THE CABINET END OF THE CABLES. SHIELDS FOR SHIELDED POWER CABLE (MOTOR LEADS) MUST BE CONNECTED AT BOTH ENDS. THE SPLICING OF SHIELDED CABLES, IF NECESSARY, SHOULD BE DONE SUCH THAT THE SHIELD(S) REMAIN CONTINUOUS AND INSULATED FROM GROUND.</p>						

This page provides a list of the non-drive peripheral components contained in the system package. The A-B part number, vendor and vendor's part number are included. Also provided is a list of remote wiring interconnections required and the acceptable wire gauges; for power, control and signal wiring. This page has a lot of useful contractor/installer type information. 91

PARAMETER	DESCRIPTION	STANDARD SETTING	AS SHIPPED SETTING	AS INSTALLED SETTING	PARAMETER	DESCRIPTION	STANDARD SETTING	AS SHIPPED SETTING	AS INSTALLED SETTING	PARAMETER	DESCRIPTION	STANDARD SETTING	AS SHIPPED SETTING	AS INSTALLED SETTING
5	FREQ SELECT 1	ADAPTER 1	DEFAULT	DEFAULT	49	BRAKE FREQUENCY	20% MAX FREQ	DEFAULT	DEFAULT	121	DATAOUT B1	0	DEFAULT	DEFAULT
6	FREQ SELECT 2	PRESET 1	DEFAULT	DEFAULT	50	BRAKE VOLTAGE	25% BRKTY	DEFAULT	DEFAULT	122	DATAOUT B2	0	DEFAULT	DEFAULT
7	ACCEL TIME 1	100 SECS	DEFAULT	DEFAULT	52	STOP SELECT 2	CONST	DEFAULT	DEFAULT	123	DATAOUT C1	0	DEFAULT	DEFAULT
8	DECEL TIME 2	100 SECS	DEFAULT	DEFAULT	56	STOP TIME	0.5 SECS	DEFAULT	DEFAULT	124	DATAOUT C2	0	DEFAULT	DEFAULT
9	DC BRK1 SELECT	AUTO BRK	DEFAULT	DEFAULT	57	S-CURVE ENABLE	DISABLED	DEFAULT	DEFAULT	125	DATAOUT D1	0	DEFAULT	DEFAULT
10	STOP SELECT 1	CONST	DEFAULT	DEFAULT	58	COMMON B1S	DISABLED	DEFAULT	DEFAULT	126	DATAOUT D2	0	DEFAULT	DEFAULT
11	BUS LAMB TH	DISABLED	DEFAULT	DEFAULT	64	SET DEFAULTS	REDEF	DEFAULT	DEFAULT	127	PROCESS 1 FREQ	1	DEFAULT	DEFAULT
12	DC HOLD TIME	0 SEC	DEFAULT	DEFAULT	71	PRESET FREQ 4	0.0 HZ	DEFAULT	DEFAULT	128	PROCESS 1 SCALE	1.00	DEFAULT	DEFAULT
13	DC HOI D LEVEL	10%V	DEFAULT	DEFAULT	74	PRESET FREQ 5	0.0 HZ	DEFAULT	DEFAULT	129	PROCESS 1 TX1	V	DEFAULT	DEFAULT
14	RIAM ON POWER UP	DISABLED	DEFAULT	DEFAULT	75	PRESET FREQ 6	0.0 HZ	DEFAULT	DEFAULT	130	PROCESS 1 TX2	0	DEFAULT	DEFAULT
15	RESUME TIME	1.0 SEC	DEFAULT	DEFAULT	76	PRESET FREQ 7	0.0 HZ	DEFAULT	DEFAULT	131	PROCESS 1 TX3	L	DEFAULT	DEFAULT
16	MANUAL FREQ	0 HZ	DEFAULT	DEFAULT	77	SRFD CONTROL	NO CONTROL	DEFAULT	DEFAULT	132	PROCESS 1 TX4	T	DEFAULT	DEFAULT
17	BASE FREQ	60 HZ	DEFAULT	DEFAULT	78	TRAVEL PERIOD	0.00 SECS	DEFAULT	DEFAULT	133	PROCESS 1 TX5	S	DEFAULT	DEFAULT
18	BASE VOLTAGE	MAX RATED	DEFAULT	DEFAULT	79	MAX TRAVEL	0.00 HZ	DEFAULT	DEFAULT	134	PROCESS 1 TX6	..	DEFAULT	DEFAULT
19	MAXIMUM FREQ	60 HZ	DEFAULT	DEFAULT	80	P JUMP	0.00 HZ	DEFAULT	DEFAULT	135	PROCESS 1 TX7	..	DEFAULT	DEFAULT
20	MANUAL FREQ	MAX RATED	DEFAULT	DEFAULT	81	RUN IN USE BIT	ENABLED	DEFAULT	DEFAULT	136	PROCESS 1 TX8	..	DEFAULT	DEFAULT
21	INPUT MODE	1	DEFAULT	2	82	CUR LDR BPHS	DISABLED	DEFAULT	DEFAULT	137	4.20V LOSS SEL	MAXIMUM	DEFAULT	DEFAULT
22	AMP LOCKMENT	1 Hz/SEC	DEFAULT	DEFAULT	83	RUN BOOST	0 V/1S	DEFAULT	DEFAULT	138	MAXIMUM SPEED	400 HZ	DEFAULT	DEFAULT
24	JOG FREQUENCY	10 HZ	DEFAULT	DEFAULT	84	ANALOG INVERT	DISABLED	DEFAULT	DEFAULT	139	ENCODER TYPE	PULSE	DEFAULT	DEFAULT
25	ANALOG OUT SEL	FREQUENCY	DEFAULT	DEFAULT	85	RESOLUTION BITS	0	DEFAULT	DEFAULT	140	ALC OUT OFFSET	DISABLED	DEFAULT	DEFAULT
27	PRESET FREQ 1	0.0 HZ	DEFAULT	DEFAULT	86	ANALOG RUN IN	DISABLED	DEFAULT	DEFAULT	141	FLYING START EN	DISABLED	DEFAULT	DEFAULT
28	PRESET FREQ 2	0.0 HZ	DEFAULT	DEFAULT	91	LOW B1S FAULT	ENABLED	DEFAULT	DEFAULT	142	FLYING START FWD	60 HZ	DEFAULT	DEFAULT
29	PRESET FREQ 3	0.0 HZ	DEFAULT	DEFAULT	92	LOCAL MASK	01111111	DEFAULT	DEFAULT	143	FS TRIP INVERSE	0 HZ	DEFAULT	DEFAULT
30	ACCEL TIME 2	100 SECS	DEFAULT	DEFAULT	93	LOCAL MASK	01111111	DEFAULT	DEFAULT	144	DIGITAL OUT SEL	ATSRFD	DEFAULT	DEFAULT
31	DECEL TIME 2	100 SECS	DEFAULT	DEFAULT	94	DIRECTION MASK	01111110	DEFAULT	DEFAULT	145	DC OUT FREQ	0.0 HZ	DEFAULT	DEFAULT
32	SRFD FREQ 1	400 HZ	DEFAULT	DEFAULT	95	START MASK	01111111	DEFAULT	DEFAULT	146	DC OUT CURRENT	0%V	DEFAULT	DEFAULT
33	SRFD FREQ 2	400 HZ	DEFAULT	DEFAULT	96	JOG MASK	01111111	DEFAULT	DEFAULT	147	DC OUT TORQUE	0.0 AMPS	DEFAULT	DEFAULT
34	SRFD FREQ 3	400 HZ	DEFAULT	DEFAULT	97	REFERENCE MASK	01111111	DEFAULT	DEFAULT	148	SRFD D1	100	DEFAULT	DEFAULT
35	SRFD FREQ 4	0 HZ	DEFAULT	DEFAULT	98	ACCEL MASK	01111111	DEFAULT	DEFAULT	149	MOTOR HP/ERRZ	1750 RPM	DEFAULT	DEFAULT
36	CURRENT LIMIT	150%V	DEFAULT	DEFAULT	99	DECEL MASK	01111111	DEFAULT	DEFAULT	150	MOTOR HP/ERRZ	60 HZ	DEFAULT	DEFAULT
37	OVERLOAD MODE	MAX OVER	DEFAULT	DEFAULT	100	FAULT MASK	01111110	DEFAULT	DEFAULT	151	PROCESS 2 FREQ	54	DEFAULT	DEFAULT
38	OVERLOAD AMPS	115% RATED A	DEFAULT	DEFAULT	101	MAP MASK	01111111	DEFAULT	DEFAULT	152	PROCESS 2 SCALE	1.00	DEFAULT	DEFAULT
39	FLT CLEAR MODE	ENABLED	DEFAULT	DEFAULT	111	DATA IN A1	0	DEFAULT	DEFAULT	153	PROCESS 2 TX1	A	DEFAULT	DEFAULT
40	LINE LOSS PAUL	ENABLED	DEFAULT	DEFAULT	112	DATA IN A2	0	DEFAULT	DEFAULT	154	PROCESS 2 TX2	M	DEFAULT	DEFAULT
41	MOTOR TYPE	INDUCTION	DEFAULT	DEFAULT	113	DATA IN B1	0	DEFAULT	DEFAULT	155	PROCESS 2 TX3	P	DEFAULT	DEFAULT
42	SL P @ F.L.A	0.0 HZ	DEFAULT	DEFAULT	114	DATA IN B2	0	DEFAULT	DEFAULT	156	PROCESS 2 TX4	S	DEFAULT	DEFAULT
43	DWELL FREQUENCY	0.0 HZ	DEFAULT	DEFAULT	115	DATA IN C1	0	DEFAULT	DEFAULT	157	PROCESS 2 TX5	..	DEFAULT	DEFAULT
44	DWELL TIME	0 SECS	DEFAULT	DEFAULT	116	DATA IN C2	0	DEFAULT	DEFAULT	158	PROCESS 2 TX6	..	DEFAULT	DEFAULT
46	PWM FREQUENCY	4 KHZ	DEFAULT	DEFAULT	117	DATA IN D1	0	DEFAULT	DEFAULT	159	PROCESS 2 TX7	..	DEFAULT	DEFAULT
47	PULSE SCALE	64 PPR	DEFAULT	DEFAULT	118	DATA IN D2	0	DEFAULT	DEFAULT	203	VI SCALING	DISABLED	DEFAULT	DEFAULT
48	LANGUAGE	ENGLISH	DEFAULT	DEFAULT	119	DATAOUT A1	0	DEFAULT	DEFAULT					
	START BOOST	0 V/1S	DEFAULT	DEFAULT	120	DATAOUT A2	0	DEFAULT	DEFAULT					

NOTE: THE "READ ONLY" PARAMETERS NOT LISTED, FOR MORE INFORMATION REFER TO PUBLICATION 1336 PLUS-5.0.

CAT# 1336S-A01SCAA-B4-CB-CC-CT-D12-D22-D4-D51-F1-M-GM-C-HACC-JF-JC-JM-JR-JT-KD-N3-ME

ACAD
 008-18-86
 3-1-94
 GZ
 LK011358MASTER
 WISSAM.E00202SH18
AB ALLEN-BRADLEY
 DRIVES AND DRIVE SYSTEMS
 MEGLEN, VA
CONFIGURATION PARAMETER LISTING
 FOR BULLETIN 1336 PLUS AC DRIVE
 PROJECT DRIVE
C-SAMPLE-0002-18
 6
 6

The Parameter Settings page provides a list of the parameters, the normal "Standard Drive" factory default values, and the special "Configured Drive" factory default values. Extra room is provided for the user to enter his own "as installed" parameter settings.

Plant-floor automation has become a dynamic cycle in which each piece of equipment purchased has to simultaneously meet current needs and anticipate future upgrades. Allen-Bradley drives are specifically engineered with this dual purpose in mind.

The Automation Investment Life Cycle ensures that your investment in Allen-Bradley automation equipment delivers the long-term productivity benefits you want. Life cycle planning provides a framework that helps you reduce costs and anticipate needs throughout the life of your automation investment.

Justify

Initial planning and justification by Allen-Bradley engineers and distributors lays the foundation for a successful long-term automation investment strategy and identifies motor control requirements.

Apply

Application and sales engineers work with you to identify the right drive for each motor. Strong commonality across the Allen-Bradley drives family simplifies the application stage for even the most complex motor control requirements.

Install

Taking advantage of the wide variety of Allen-Bradley drive packaging options to ease installation, an experienced engineering team assists you with all aspects of system start up.

Operate

Thoughtful planning and installation translate to simple and cost-effective operation. Sophisticated programming tools and the proven reliability of Allen-Bradley drives allow for dependable, unsupervised operation that will help you meet productivity and performance goals.

Maintain

Complete parts repair service and inventory management from Allen-Bradley Global Technical Services, coupled with the built-in troubleshooting capabilities of Allen-Bradley drives, simplify maintenance and enhance productivity.

Improve

The built-in expandability and flexibility of Allen-Bradley drives protects your automation investment by allowing you to take advantage of design improvements and technological innovations.

The Automation Investment Life Cycle™



Today's manufacturers must build greater flexibility into their automation systems to meet ever-changing customer demands for more, less expensive product in less time. This era of flexibility and cost is changing what used to be viewed as one-time automation purchases to long-term productivity benefits.

Allen-Bradley calls this the Automation Investment Life Cycle. Beyond the initial purchase price, Allen-Bradley is helping manufacturers and processors understand and reduce costs associated with justifying, applying, installing, operating, maintaining and upgrading their automation system.

The 1336 Configured drive was designed to add value and reduce costs in all stages of the cycle.

The Automation Investment Life Cycle, The Automation Investment Life Cycle Symbol, 1336 FORCE, 1336 IMPACT, ControlNet, DriveTools, Flex, Panelview, PLC, SCANport, SLC, and SMC Dialog Plus are trademarks of Allen-Bradley Co., Inc.

Microsoft and Windows are trademarks of Microsoft Corporation.

DeviceNet is a trademark of the Open DeviceNet Vendor Association.



The Configured Drives Program provides special drive packages with instruction manuals and complete, order-specific drawings that exceed the offerings of a standard drive product. Most of the available options, such as control, communications, power, packaging and documentation, are completely pre-defined and manufacturing begins almost immediately after order entry. The 1336 PLUS Configured AC drive is available in ratings of 0.37 – 93 kW (0.5 – 125 HP) at 230 volts, 0.37 – 448 kW (0.5 – 600 HP) at 460 volts, and 0.75 – 448 kW (1 – 600 HP) at 575 volts.



Allen-Bradley, a Rockwell Automation Business, has been helping its customers improve productivity and quality for more than 90 years. We design, manufacture and support a broad range of automation products worldwide. They include logic processors, power and motion control devices, operator interfaces, sensors and a variety of software. Rockwell is one of the world's leading technology companies.

Worldwide representation.



Argentina • Australia • Austria • Bahrain • Belgium • Brazil • Bulgaria • Canada • Chile • China, PRC • Colombia • Costa Rica • Croatia • Cyprus • Czech Republic • Denmark • Ecuador • Egypt • El Salvador • Finland • France • Germany • Greece • Guatemala • Honduras • Hong Kong • Hungary • Iceland • India • Indonesia • Ireland • Israel • Italy • Jamaica • Japan • Jordan • Korea • Kuwait • Lebanon • Malaysia • Mexico • Netherlands • New Zealand • Norway • Pakistan • Peru • Philippines • Poland • Portugal • Puerto Rico • Qatar • Romania • Russia-CIS • Saudi Arabia • Singapore • Slovakia • Slovenia • South Africa, Republic • Spain • Sweden • Switzerland • Taiwan • Thailand • Turkey • United Arab Emirates • United Kingdom • United States • Uruguay • Venezuela

Allen-Bradley Headquarters, 1201 South Second Street, Milwaukee, WI 53204 USA, Tel: (1) 414 382-2000 Fax: (1) 414 382-4444